

Surge Protection Made Simple™ for IEC Applications

IEC Class II Surge Arresters for 230/400 Volt, 4-Pole TNS & TT Systems



Description

The Cooper Bussmann® IEC Class II 230/400 volt, four-pole, modular surge arresters feature local, *easyID*™ visual indication and optional remote contact signaling. The unique module locking system fixes the protection module to the base part. Modules can be easily replaced without tools by simply depressing the release buttons. Integrated mechanical coding between the base and protection module ensures against installing an incorrect replacement module.

These 230 Volt models are offered with MCOV ratings of 275, 320 or 385 volts.

TNS System Arrester

The features of these four-pole devices are for use in TNS 230/400 volt systems ("4-0" circuit) against surges.

TT System Arrester

The features of these four-pole devices are for use in TT and TN-S 230/400 volt systems ("3+1" circuit) against surges.

Remote Signaling Contact

The three-pole terminal remote signaling contact versions have a floating changeover contact for use as a break or make contact, according to circuit concept.



BSPM4275TNS(R)
BSPH4275TT(R)
BSPH4320TT(R)
BSPH4385TT(R)



easyID™
Visual Status Indication



Remote Signal Contact Available



Dimensions - mm

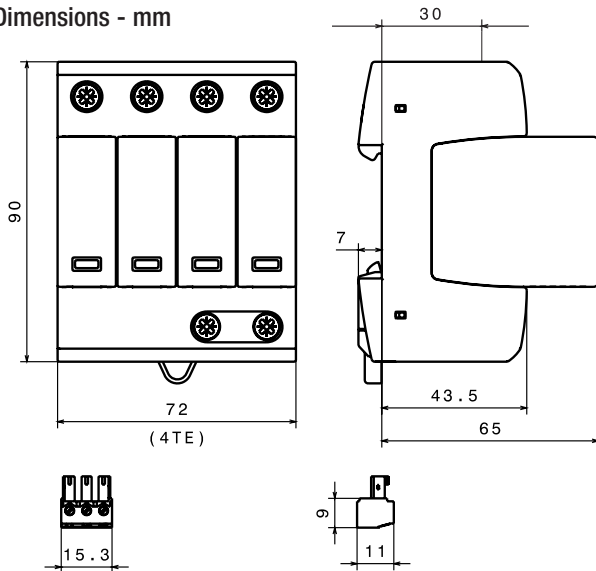

Shown with optional remote contact signaling

Circuit Diagrams

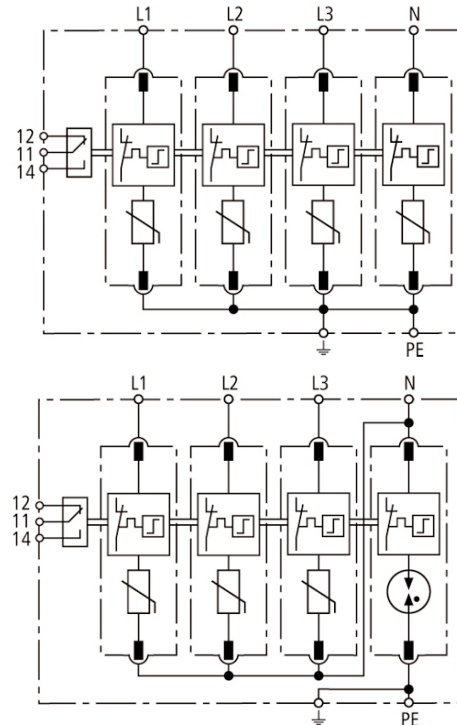

BSPM4275TNS(R)

Shown with optional remote contact signaling

- MOV
- Thermal Disconnector
- Gas Discharge Tube (single)

BSPH4275TT(R)

BSPH4320TT(R)
BSPH4385TT(R)

Shown with optional remote contact signaling

ORDERING INFORMATION					
System Voltage/Poles		230V/4	230V/4	230V/4	230V/4
Max. continuous operating AC voltage (MCOV) [U _C]		275V	--	--	--
Max. continuous operating AC voltage (MCOV) [L-N] [U _C]		--	275V	320V	385V
Max. continuous operating AC voltage [N-PE] [U _C]		--	255V	255V	255V
Catalog Numbers:	Without Remote Signaling	BSPM4275TNS	BSPH4275TT	BSPH4320TT	BSPH4385TT
	With Remote Signaling	BSPM4275TNSR	BSPH4275TTR	BSPH4320TTR	BSPH4385TTR
Replacement Modules:	MOV technology	BPM275IEC	BPM275IEC	BPM320IEC	BPM385IEC
	Spark Gap technology	--	BPSNPEIEC*	BPSNPEIEC*	BPSNPEIEC*
SPECIFICATIONS					
Lightning impulse current (10/350 μs) [N-PE] [I _{imp}]		--	12kA	12kA	12kA
Voltage protection level [U _p]		≤ 1.25kV	--	--	--
Voltage protection level at 5kA [U _p]		≤ 1kV	--	--	--
Voltage protection level [L-N] [U _p]		--	≤ 1.25kV	≤ 1.5kV	≤ 1.75kV
Voltage protection level [L-N] at 5kA [U _p]		--	≤ 1kV	≤ 1.2kV	≤ 1.35kV
Voltage protection level [N-PE] [U _p]		--	≤ 1.5kV	≤ 1.5kV	≤ 1.5kV
Follow current extinguishing capability [N-PE] [I _{fi}]		--	100A _{rms}	100A _{rms}	100A _{rms}
Response time [t _A]		≤ 25 ns	--	--	--
Response time [L-N] [t _A]		--	≤ 25 ns	≤ 25 ns	≤ 25 ns
Response time [N-PE] [t _A]		--	≤ 100 ns	≤ 100 ns	≤ 100 ns
Temporary overvoltage (TOV) [U _T]		335V/5 sec.	--	--	--
Temporary overvoltage (TOV) [L-N] [U _T]		--	335V/5 sec.	335V/5 sec.	385V/5 sec.
Temporary overvoltage (TOV) [N-PE] [U _T]		--	1200V/200 ms	1200V/200 ms	1200V/200 ms
Short-circuit withstand capability for max. mains-side overcurrent protection		50kA _{rms}	50kA _{rms}	25kA _{rms}	25kA _{rms}
SPD according to EN 61643-11		Type 2			
SPD according to IEC 61643-1		Class II			
Nominal AC voltage [U _N]		230/400V			
Nominal discharge current (8/20 μs) [I _n]		20kA			
Max. discharge current (8/20 μs) [I _{max}]		40kA			
Max. mains-side overcurrent protection		125A gL/gG			
TOV characteristics		withstand			
Operating temperature range [T _U]		-40°C to +80°C			
Operating state/fault indication		green (good)/red (replace)			
Number of ports		1			
Cross-sectional area (min.)		1.5mm ² /14AWG solid/flexible			
Cross-sectional area (max.)		35mm ² /2AWG stranded-25mm ² /4AWG flexible			
Mounting		35mm DIN rail per EN 60715			
Enclosure material		Thermoplastic, UL 94V0			
Location category		Indoor			
Degree of protection		IP20			
Capacity		4 mods., DIN 43880			
Standards Information		KEMA			
Product Warranty		Five Years**			
REMOTE CONTACT SIGNALING					
Remote Contact Signaling Type		Changeover Contact			
AC Switching Capacity (Volts/Amps)		250V/0.1A			
DC Switching Capacity (Volts/Amps)		250V/0.1A; 125V/0.2A; 75V/0.5A			
Conductor Ratings and Cross-Sectional Area for Remote Contact Signal Terminals		60/75°C Max. 1.5mm ² /14AWG Solid/Flexible			
Ordering Information		Order from Catalog Numbers Above			

* N-PE Surge arrester module for location between neutral conductor and protective conductor in TT systems.

** See Cooper Bussmann SPD Limited Warranty Statement (3A1502) for details at www.cooperbussmann.com/surge.

Recommended Cooper Bussmann Back Up Fuses	
DIN Fuse Size	NH Fuse Part Number
00	125NHG00B
0	125NHG0B
01	125NHG01B
02	125NHG02B

The only controlled copy of this Data Sheet is the electronic read-only version located on the Cooper Bussmann Network Drive. All other copies of this document are by definition uncontrolled. This bulletin is intended to clearly present comprehensive product data and provide technical information that will help the end user with design applications. Cooper Bussmann reserves the right, without notice, to change design or construction of any products and to discontinue or limit distribution of any products. Cooper Bussmann also reserves the right to change or update, without notice, any technical information contained in this bulletin. Once a product has been selected, it should be tested by the user in all possible applications.

Компания «Океан Электроники» предлагает заключение долгосрочных отношений при поставках импортных электронных компонентов на взаимовыгодных условиях!

Наши преимущества:

- Поставка оригинальных импортных электронных компонентов напрямую с производств Америки, Европы и Азии, а так же с крупнейших складов мира;
- Широкая линейка поставок активных и пассивных импортных электронных компонентов (более 30 млн. наименований);
- Поставка сложных, дефицитных, либо снятых с производства позиций;
- Оперативные сроки поставки под заказ (от 5 рабочих дней);
- Экспресс доставка в любую точку России;
- Помощь Конструкторского Отдела и консультации квалифицированных инженеров;
- Техническая поддержка проекта, помощь в подборе аналогов, поставка прототипов;
- Поставка электронных компонентов под контролем ВП;
- Система менеджмента качества сертифицирована по Международному стандарту ISO 9001;
- При необходимости вся продукция военного и аэрокосмического назначения проходит испытания и сертификацию в лаборатории (по согласованию с заказчиком);
- Поставка специализированных компонентов военного и аэрокосмического уровня качества (Xilinx, Altera, Analog Devices, Intersil, Interpoint, Microsemi, Actel, Aeroflex, Peregrine, VPT, Syfer, Eurofarad, Texas Instruments, MS Kennedy, Miteq, Cobham, E2V, MA-COM, Hittite, Mini-Circuits, General Dynamics и др.);

Компания «Океан Электроники» является официальным дистрибьютором и эксклюзивным представителем в России одного из крупнейших производителей разъемов военного и аэрокосмического назначения «JONHON», а так же официальным дистрибьютором и эксклюзивным представителем в России производителя высокотехнологичных и надежных решений для передачи СВЧ сигналов «FORSTAR».



JONHON

«JONHON» (основан в 1970 г.)

Разъемы специального, военного и аэрокосмического назначения:

(Применяются в военной, авиационной, аэрокосмической, морской, железнодорожной, горно- и нефтедобывающей отраслях промышленности)

«FORSTAR» (основан в 1998 г.)

ВЧ соединители, коаксиальные кабели,
кабельные сборки и микроволновые компоненты:

(Применяются в телекоммуникациях гражданского и специального назначения, в средствах связи, РЛС, а так же военной, авиационной и аэрокосмической отраслях промышленности).



Телефон: 8 (812) 309-75-97 (многоканальный)

Факс: 8 (812) 320-03-32

Электронная почта: ocean@oceanchips.ru

Web: <http://oceanchips.ru/>

Адрес: 198099, г. Санкт-Петербург, ул. Калинина, д. 2, корп. 4, лит. А