

## LED Driver IC with Wide Input Voltage Range

### Features

- ▶ Adjustable output current
- ▶ Universal 10VDC to 80 - 264VAC input
- ▶ Programmable clamped-mode switching
- ▶ Programmable switching OFF-time
- ▶ Internal 700V power MOSFET

### Applications

- ▶ LED backlighting
- ▶ LED backlit switches
- ▶ Automation controls

### General Description

The HV9821 is a clamped-mode high-side buck converter IC for driving a low-voltage LED load at constant current programmable up to 50mA (or higher, as permitted by power dissipation, etc.). The IC limits peak voltage at its switching output to a level programmed by connecting an external Zener diode. This feature ensures a reasonable on-time of the switch, while minimizing the conduction power loss of the HV9821. The IC operates with fixed off-time, programmable externally with a resistor.

The IC is equipped with over-temperature protection and packaged in a 19-Lead 7mm x 5mm DFN package.

### Typical Application Circuit

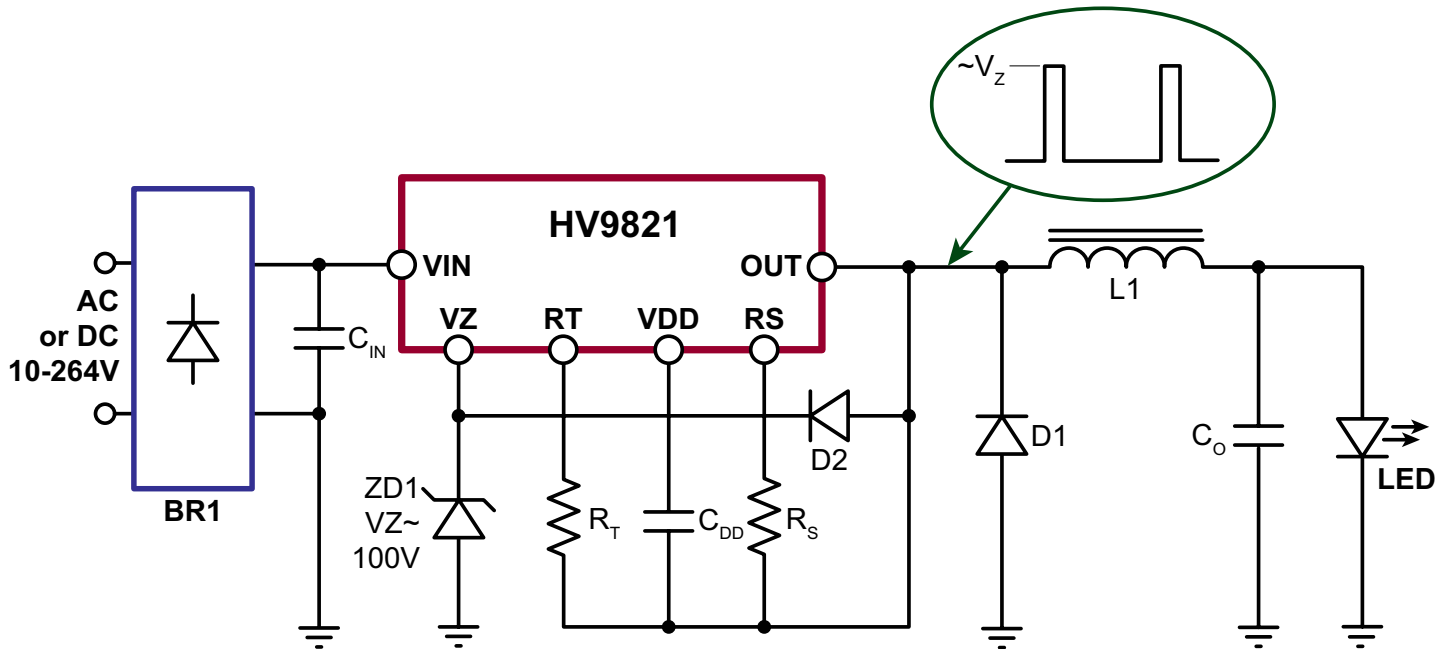

## Ordering Information

Part Number	Package Option	Packing
HV9821K7-G	19-Lead DFN (7x5)	364/Tray

-G denotes a lead (Pb)-free / RoHS compliant package

## Absolute Maximum Ratings

Parameter	Value
Supply voltage, VDD	-0.3V to +13.5V
Gate driver, VZ	-0.7V to +13.5V
Other I/O	-0.3V to +13.5V
Supply current, IDD	5.0mA
RT current	2.0mA
Operating temperature	-40°C to +125°C
Storage temperature	-65°C to +150°C
Power dissipation @ 25°C	3.3W

The power dissipation is given for the standard minimum pad without a heat slug, and based on  $\theta_{ja} = 30^{\circ}\text{C/W}$

Stresses beyond those listed under "Absolute Maximum Ratings" may cause permanent damage to the device. These are stress ratings only, and functional operation of the device at these or any other conditions beyond those indicated in the operational sections of the specifications is not implied. Exposure to absolute maximum rating conditions for extended periods may affect device reliability.

## Electrical Characteristics

(Unless otherwise specified: All voltages referenced to OUT pin,  $T_A = 25^{\circ}\text{C}$ ,  $R_T = 100\text{k}\Omega$ ,  $V_{IN} = 20\text{V}$ ,  $R_S = \text{OUT}$ , VZ open. Typical characteristics are specified at  $T_A = 25^{\circ}\text{C}$ .)

Sym	Description	Min	Typ	Max	Units	Conditions
-----	-------------	-----	-----	-----	-------	------------

### Voltage Regulator (VIN, VDD)

$V_{DD}$	Regulator output voltage	*	-	9.0	-	V	---
$V_{DD(UV)}$	VDD under-voltage threshold	-	-	3.0	-	V	$V_{DD}$ falling ↓
$\Delta V_{DD(UV)}$	VDD hysteresis	-	-	0.4	-	V	$V_{DD}$ rising ↑
$I_{DDQ}$	Operating supply current	-	-	-	800	μA	---

### Output Switch (VIN, RS)

BV	VIN breakdown voltage	*	700	-	-	V	---
$R_{ON}$	ON-resistance	*	-	60	150	Ω	---
$I_{SAT}$	VIN saturation current	* #	150	-	-	mA	$V_{RS} = 1.0\text{V}$
$V_{GS}$	VZ-to-RS voltage	-	-	2.0	-	V	$I_{IN} = 50\text{mA}$

#### Notes:

- \* Specifications which apply over the full operating ambient temperature range of  $-40^{\circ}\text{C} < T_A < +125^{\circ}\text{C}$ , guaranteed by design and characterization.
- # Specifications guaranteed by design

## Pin Configuration

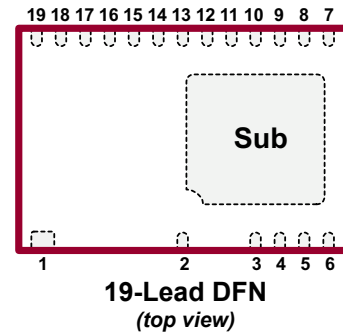

## Product Marking



L = Lot Number  
 YY = Year Sealed  
 WW = Week Sealed  
 A = Assembler ID  
 C = Country of Origin  
 — = "Green" Packaging

Package may or may not include the following marks: Si or

### 19-Lead DFN

## Typical Thermal Resistance

Package	$\theta_{ja}$
19-Lead DFN	30°C/W

## Electrical Characteristics

(Unless otherwise specified: All voltages referenced to OUT pin,  $T_A = 25^\circ\text{C}$ ,  $R_T = 100\text{k}\Omega$ ,  $V_{IN} = 20\text{V}$ ,  $R_S = \text{OUT}$ ,  $V_Z$  open. Typical characteristics are specified at  $T_A = 25^\circ\text{C}$ .)

Sym	Description	Min	Typ	Max	Units	Conditions
-----	-------------	-----	-----	-----	-------	------------

### Gate Driver (VZ)

$I_{VZ(+)}$	VZ source current	*	-	-	13	mA	During $T_{\text{BLANK}}$ , $V_{\text{DD}} = 8.0\text{V}$
$I_{VZ(-)}$	VZ sink current	*	-	6.5	-	mA	$V_{\text{DD}} = 8.0\text{V}$
$I_{VZ(\text{BIAS})}$	VZ bias current	*	-	100	200	$\mu\text{A}$	$V_{\text{DD}} = 8.0\text{V}$

### $T_{\text{OFF}}$ Timer (RT)

$T_{\text{OFF}}$	OFF time	-	9.2	10.5	11.8	$\mu\text{s}$	$R_T = 100\text{k}\Omega$
$T_{\text{OFF}(\text{MAX})}$	Maximum OFF time	-	88	110	132	$\mu\text{s}$	$R_T = 1.0\text{M}\Omega$

### Current Sense Comparator (RS)

$V_{\text{TH}}$	Threshold voltage	*	0.40	0.50	0.60	V	---
$T_{\text{BLANK}}$	Leading edge blanking delay	*	200	-	400	ns	---
$T_{\text{DELAY}}$	Propagation delay RS to VIN	*	-	-	150	ns	---

### Over-temperature Protection

$T_{\text{OT}}$	Over temperature threshold	-	125	-	-	$^\circ\text{C}$	---
$\Delta T_{\text{HYST}}$	Temperature hysteresis	-	-	20	-	$^\circ\text{C}$	---

#### Notes:

\* Specifications which apply over the full operating ambient temperature range of  $-40^\circ\text{C} < T_A < +125^\circ\text{C}$ , guaranteed by design and characterization.

## Functional Block Diagram

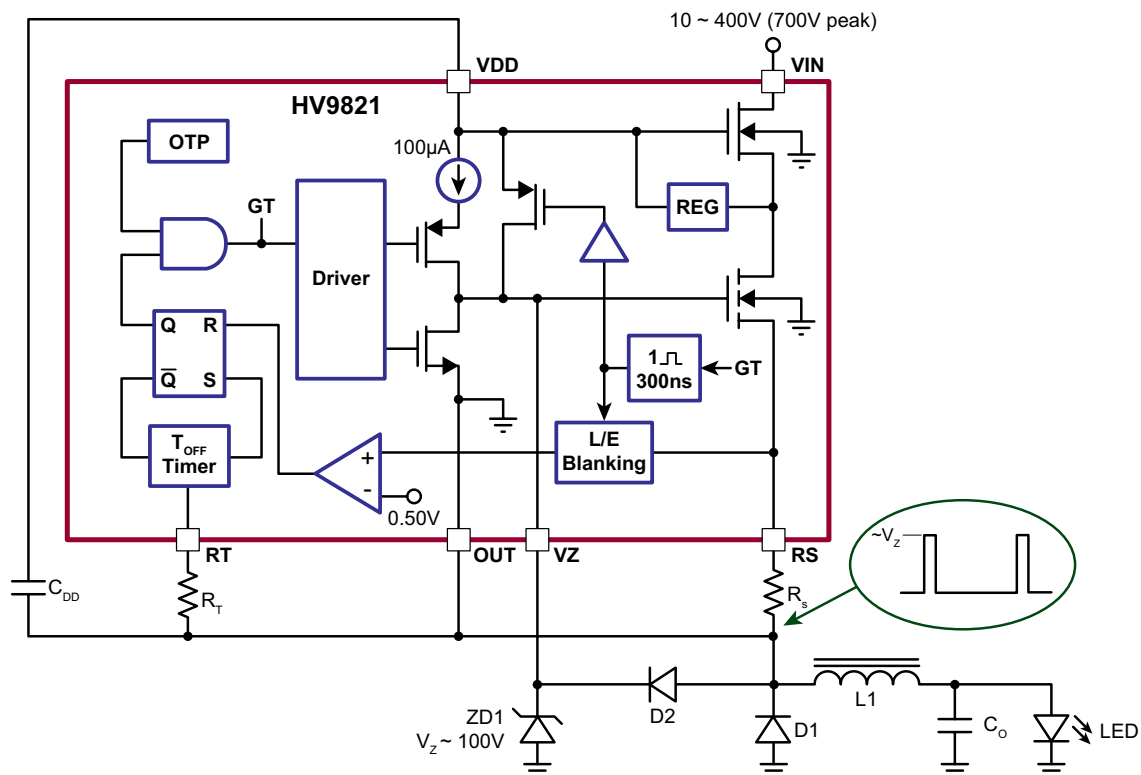

## Power Topology

The HV9821 is a clamped-mode buck converter for driving a low-voltage LED load at a fixed current up to 50mA (or higher, as permitted by power dissipation, voltage drop and saturation current) from a wide range of input voltage of 10 to 700V. The IC generates a switching waveform of programmable amplitude  $V_{OUT}$  to accommodate the minimum duty cycle limitation. Since the input current can be determined as  $I_{IN} = I_O \cdot D$ , where  $D = V_O / V_{OUT}$ , the conduction losses due to the clamped mode are manageable:

$$P_{COND} = \left[ V_O \cdot I_O + V_O \cdot I_{VZ(BIAS)} + I_{VZ(+)} \cdot (V_{OUT} - V_O) \cdot \frac{T_{BL}}{T_{OFF}} \right] \cdot \left( \frac{V_{IN}}{V_{OUT}} - 1 \right) + V_{IN} \cdot I_{DD(Q)}$$

where  $V_{OUT} = V_Z - 2V$ ,  $I_{DD(Q)} = 800\mu A(max)$ ,  $I_{VZ(BIAS)} = 200\mu A(max)$ ,  $I_{VZ(+)} = 13mA(max)$ , and  $T_{BL} = 400ns(max)$ . The inductor value can be chosen in accordance with:

$$L_O = \frac{V_{OUT} \cdot T_{OFF}}{\Delta I_L}$$

where  $\Delta I_L$  is the desired inductor current peak-to-peak ripple. The LED current is programmed by selecting the current sense resistor in accordance with the following equation:

$$R_{CS} = \frac{0.50V}{I_{OUT} - \frac{1}{2}\Delta I_L}$$

At low input voltage, parasitic resistances such as  $R_{ON}$  of the HV9821, DCR of the inductor, and sense resistor  $R_S$  start playing a major role. The 0.50V reference voltage can no longer develop at  $R_S$ , and the HV9821 high-voltage switch remains in the on-state. At this condition, the internal regulator cannot power the IC, and the VDD voltage ramps down at the rate of  $I_{DD(Q)} / C_{DD}$ . When  $V_{DD}$  drops below 3.0V, the high-voltage switch turns off. The capacitor  $C_{DD}$  is charged to 3.4V. (See Figure 3.) Thus, at the described low input voltage condition, the HV9821 no longer maintains constant LED current, but rather enters a resistive mode of operation with periodical brief interruption to replenish charge in  $C_{DD}$ . The on-time between such interruptions is determined as  $T_{ON} = 0.4V \cdot C_{DD} / I_{DD(Q)}$ .

## Voltage Clamp

The voltage limit at OUT is determined by breakdown voltage  $V_Z$  of an external Zener diode connected at VZ. The gate drive current of the internal power MOSFET is diverted into VZ, when the voltage reaches  $V_Z$ . Hence, the voltage at OUT becomes clamped to  $\sim V_Z$ . For the duration of the leading-edge blanking delay of 300ns, this current can be up to 10mA. The current is further reduced to 100 $\mu A$  to minimize power dissipation in the Zener diode.

Connection of a Schottky diode between OUT and VZ prevents latch-up conditions due to parasitic charge redistribution in the switching circuit.

The VZ pin can be left open. In this case, the circuit shall function as a switching converter with the OUT voltage  $V_{OUT} = V_{IN}$ .

## Regulator

The off state of the switch is used by an internal voltage regulator to derive the 9.0V supply at VDD from VIN for the control circuits.

## Current Sense Comparator

The comparator terminates the gate driver on-state to pull the gate of the cascoded internal switching transistor to OUT, when the voltage at RS exceeds 0.50V. The 300ns leading-edge blanking delay prevents false tripping of the comparator.

## OFF Timer

The IC operates with fixed off time of the power switch. This time duration is programmed with an external resistor at  $R_T$  in accordance with the equation  $T_{OFF} = R_T \cdot 100pF$ .

## Over-Temperature Protection

The HV9821 is protected from over-temperature by turning the internal voltage regulator off at a temperature threshold greater than 125°C. Minimum current shall be consumed by the IC until the junction temperature falls by 20°C.

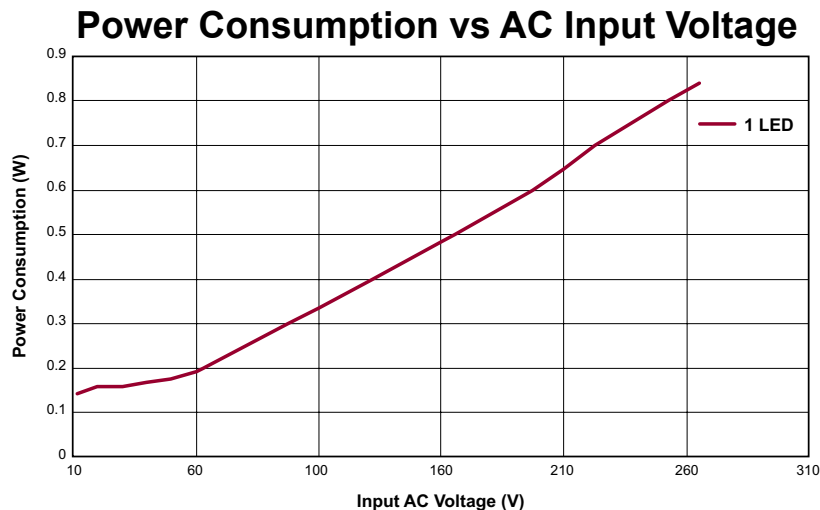

Figure 1. Power consumption as a function of the input AC voltage:  $V_{OUT} = 2.9V$ ,  $V_Z = 91V$

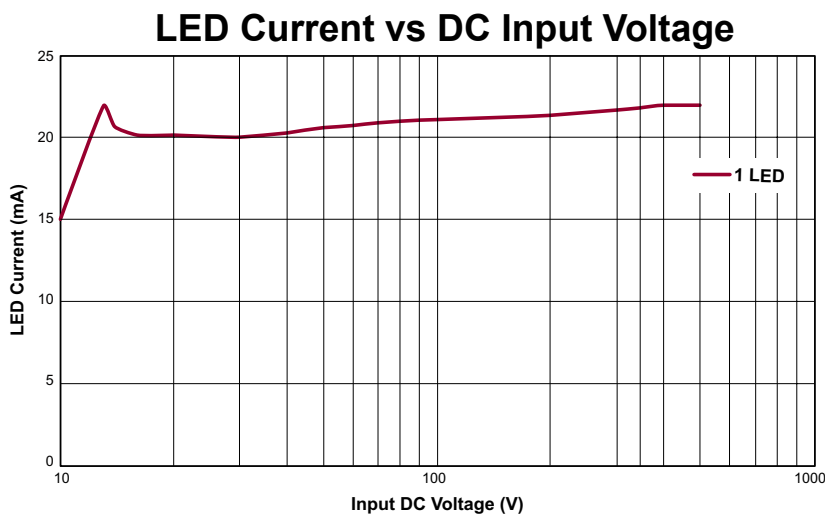

Figure 2. Input DC voltage regulation of LED current:  $V_{OUT} = 2.9V$ ,  $V_Z = 91V$

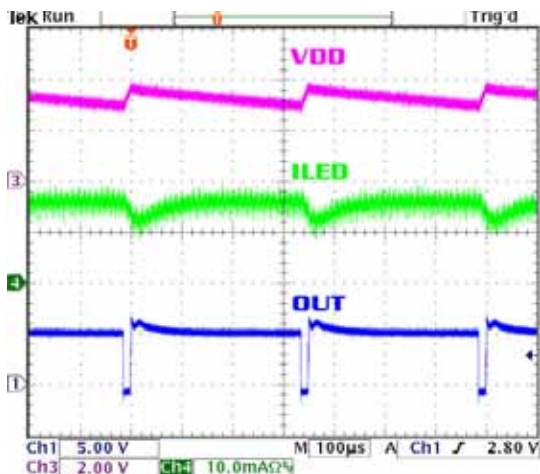

Figure 3. Low input voltage condition:  $V_{IN} = 10V$ ,  $V_{OUT} = 2.9V$ .

## Pin Description (19-Lead DFN)

Pin	Name	Description
1	VIN	Input supply positive.
2	OUT	Circuit common.
3	RS	Source terminal of internal MOSFET, current sense resistor connection.
4	VZ	Gate driver output, Zener clamp connection.
5	RT	T <sub>OFF</sub> programming pin, timing resistor connection.
6	VDD	Internally regulated 9V supply voltage to all circuits. A bypass capacitor to OUT of at least 1.0μF required.
7-19	OUT	Circuit common.
sub	OUT	Circuit common.

# 19-Lead DFN Package Outline (K7)

7.00x5.00mm body, 0.80mm height (max), 0.50mm pitch

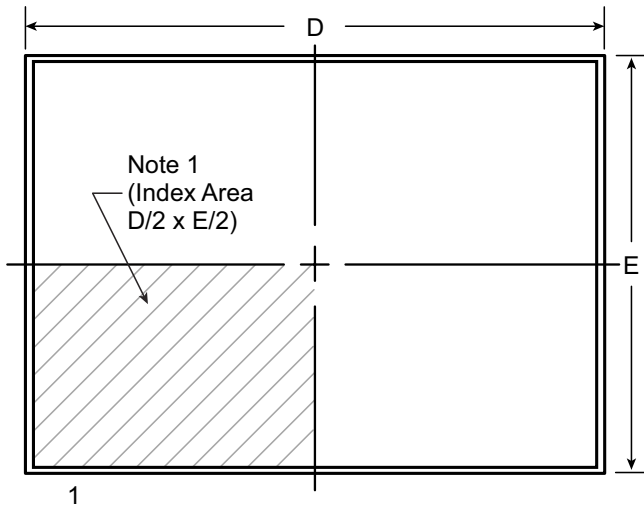

**Top View**

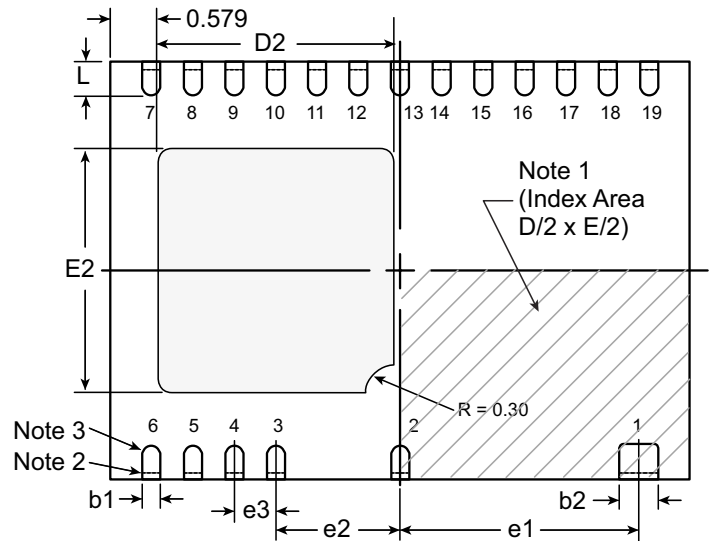

**Bottom View**

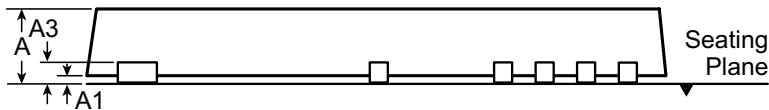

**Side View**

**Notes:**

1. A Pin 1 identifier must be located in the index area indicated. The Pin 1 identifier can be: a molded mark/identifier; an embedded metal marker; or a printed indicator.
2. Depending on the method of manufacturing, a maximum of 0.15mm pullback (L1) may be present.
3. The inner tip of the lead may be either rounded or square.

Symbol		A	A1	A3	b1	b2	D	D2	E	E2	e1	e2	e3	L
Dimension (mm)	MIN	0.70	0.00	0.20 REF	0.20	0.42	7.00 BSC	2.692	5.00 BSC	2.802	2.875 BSC	1.50 BSC	0.50 BSC	0.30
	NOM	0.75	0.02		0.25	0.47		2.842		2.952				0.40
	MAX	0.80	0.05		0.30	0.52		2.942		3.052				0.50

Drawings not to scale.

Supertex Doc.#: DSPD-19DFNK77X5P050, Version A053012.

(The package drawing(s) in this data sheet may not reflect the most current specifications. For the latest package outline information go to <http://www.supertex.com/packaging.html>.)

Supertex inc. does not recommend the use of its products in life support applications, and will not knowingly sell them for use in such applications unless it receives an adequate "product liability indemnification insurance agreement." Supertex inc. does not assume responsibility for use of devices described, and limits its liability to the replacement of the devices determined defective due to workmanship. No responsibility is assumed for possible omissions and inaccuracies. Circuitry and specifications are subject to change without notice. For the latest product specifications refer to the Supertex inc. (website: <http://www.supertex.com>)

Компания «Океан Электроники» предлагает заключение долгосрочных отношений при поставках импортных электронных компонентов на взаимовыгодных условиях!

Наши преимущества:

- Поставка оригинальных импортных электронных компонентов напрямую с производств Америки, Европы и Азии, а так же с крупнейших складов мира;
- Широкая линейка поставок активных и пассивных импортных электронных компонентов (более 30 млн. наименований);
- Поставка сложных, дефицитных, либо снятых с производства позиций;
- Оперативные сроки поставки под заказ (от 5 рабочих дней);
- Экспресс доставка в любую точку России;
- Помощь Конструкторского Отдела и консультации квалифицированных инженеров;
- Техническая поддержка проекта, помощь в подборе аналогов, поставка прототипов;
- Поставка электронных компонентов под контролем ВП;
- Система менеджмента качества сертифицирована по Международному стандарту ISO 9001;
- При необходимости вся продукция военного и аэрокосмического назначения проходит испытания и сертификацию в лаборатории (по согласованию с заказчиком);
- Поставка специализированных компонентов военного и аэрокосмического уровня качества (Xilinx, Altera, Analog Devices, Intersil, Interpoint, Microsemi, Actel, Aeroflex, Peregrine, VPT, Syfer, Eurofarad, Texas Instruments, MS Kennedy, Miteq, Cobham, E2V, MA-COM, Hittite, Mini-Circuits, General Dynamics и др.);

Компания «Океан Электроники» является официальным дистрибьютором и эксклюзивным представителем в России одного из крупнейших производителей разъемов военного и аэрокосмического назначения «JONHON», а так же официальным дистрибьютором и эксклюзивным представителем в России производителя высокотехнологичных и надежных решений для передачи СВЧ сигналов «FORSTAR».



## JONHON

«JONHON» (основан в 1970 г.)

Разъемы специального, военного и аэрокосмического назначения:

(Применяются в военной, авиационной, аэрокосмической, морской, железнодорожной, горно- и нефтедобывающей отраслях промышленности)

«FORSTAR» (основан в 1998 г.)

ВЧ соединители, коаксиальные кабели, кабельные сборки и микроволновые компоненты:

(Применяются в телекоммуникациях гражданского и специального назначения, в средствах связи, РЛС, а так же военной, авиационной и аэрокосмической отраслях промышленности).



Телефон: 8 (812) 309-75-97 (многоканальный)

Факс: 8 (812) 320-03-32

Электронная почта: [ocean@oceanchips.ru](mailto:ocean@oceanchips.ru)

Web: <http://oceanchips.ru/>

Адрес: 198099, г. Санкт-Петербург, ул. Калинина, д. 2, корп. 4, лит. А