



Metal Oxide Varistor

Disc type

SIOV-Q14K550

Ordering code: B72214Q0551K101

Data sheet

Form: FBLE3K/b

File name: Q14K550_a

MODIFICATIONS: New data sheet

REMARKS:

Prepared by	Hotwagner	Release	signed: PE / Hotwagner		signed: QS / Zödl		
			signed:		signed:		
ISSUE DATE	22.05.02	ISSUE	a	PUBLISHER	KH PE VAR	PAGE	0/6

SIOV nomenclature

Q	=	EnergetiQ™ Series
14	=	Rated disk diameter
K	=	Tolerance of V_V at 1mA : $\pm 10\%$
550	=	Max. AC voltage

Figure: Dimensions given in Millimeters (mm)

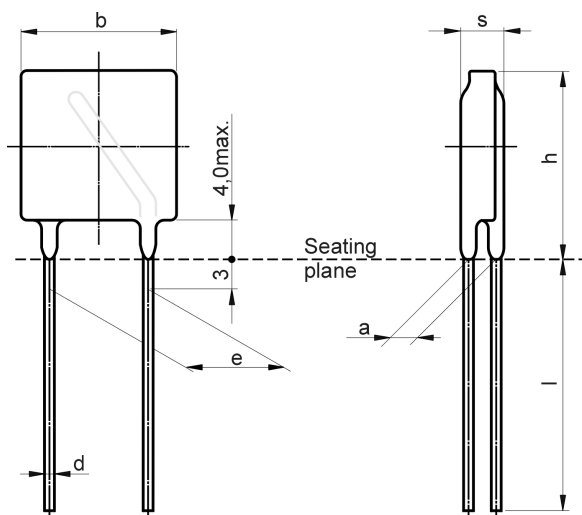

b_{max}	=	16,5
h_{max}	=	19,5
s_{max}	=	9,0
e	=	$10,0 \pm 1,0$
a	=	$4,8 \pm 1,0$
l_{min}	=	30,0
$\varnothing d$	=	$1,0 \pm 0,05$

Electrical data:

Maximum Ratings (85°C):

Max. operating AC voltage	V_{RMS}	=	550V
Max. operating DC voltage	V_{DC}	=	745V
Surge current (8/20 μ s) 1 time	I_{max}	=	6000A
Energy absorption (2ms) 1 time	W_{max}	=	260J
Average power dissipation	P_{max}	=	0,80W

Characteristics (25°C):

Varistor voltage at 1mA	V_V	=	$910V \pm 10\%$
Clamping voltage at 65A (8/20 μ s)	$V_{C,max}$	=	1500V
Typ. capacitance at 1 kHz	C	=	245pF

ISSUE DATE	22.05.02	ISSUE	a	PUBLISHER	KH PE VAR	PAGE	1/6
------------	----------	-------	---	-----------	-----------	------	-----

Data sheet

V/I Characteristic:

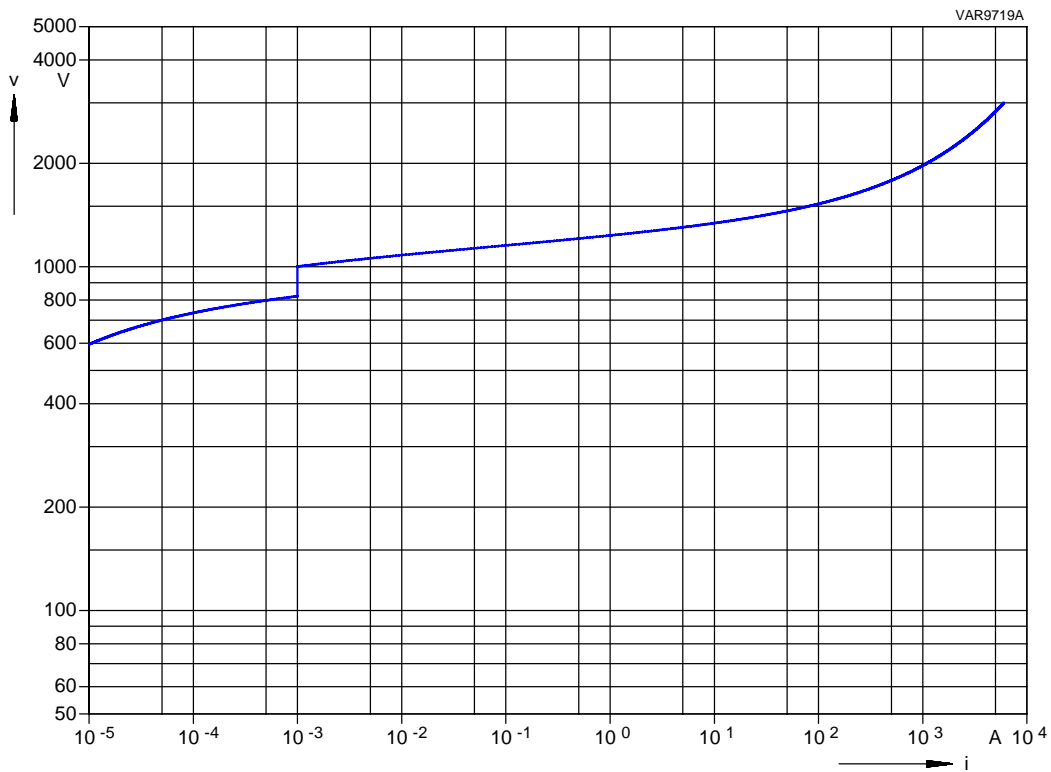

Derating:

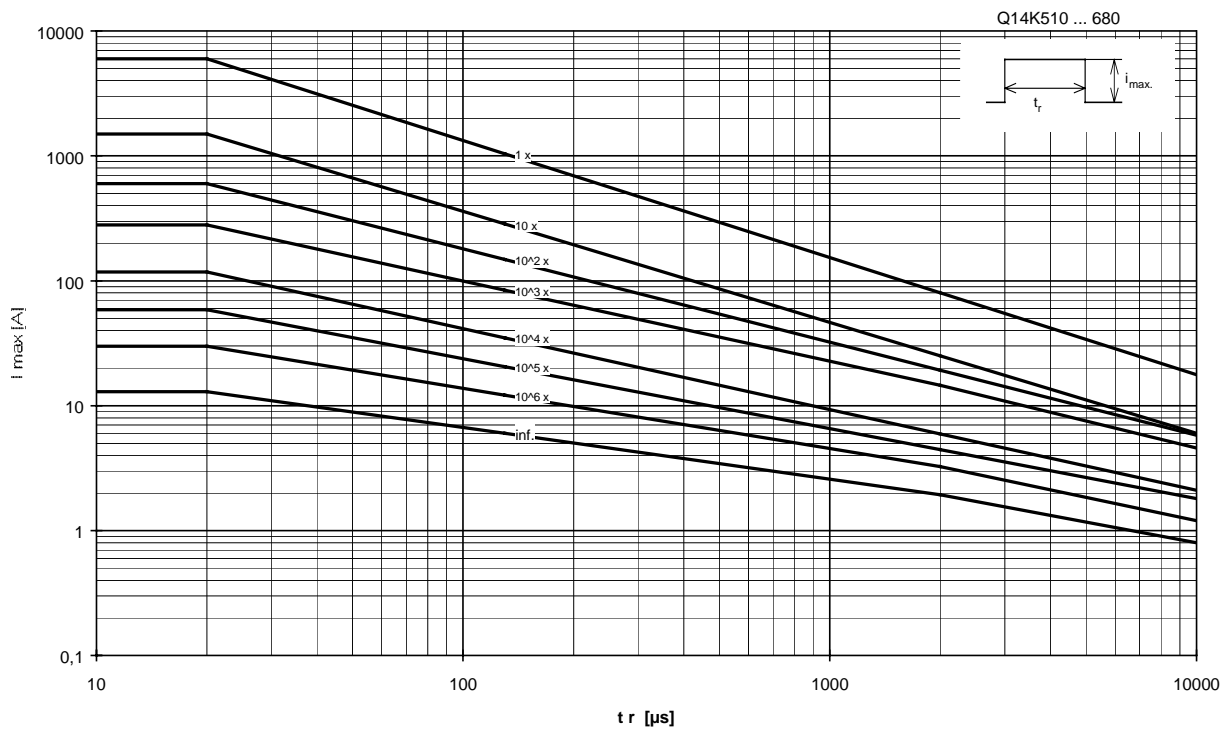

Reliability Data:

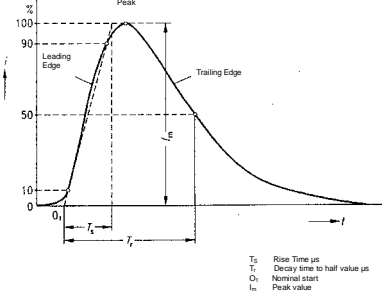
	Characteristics	Test Methods/Description	Specifications
E	Varistor Voltage	The voltage between two terminals with the specified measuring current applied is called V_V (1 mA _{DC} @ 0.2 - 2 s).	To meet the specified value.
L E C T R I C A L	Clamping Voltage	<p>The maximum voltage between two terminals with the specified standard impulse current (8/20µs) illustrated below applied.</p>  <p style="font-size: small;"> T_2 Rise Time µs T_1 Decay time to half value µs O_1 Nominal start I_m Peak value </p>	To meet the specified value.
C	Surge current derating, 8/20 µs	100 surge currents (8/20 µs), unipolar, interval 30 s, amplitude corresponding to derating curve for 20 µs	$ \Delta V/V (1 \text{ mA}) \leq 10 \%$ (measured in direction of surge current) No visible damage
L	Surge current derating, 2 ms	100 surge currents (2ms), unipolar, interval 120s, amplitude corresponding to derating curve for 2ms	$ \Delta V/V (1 \text{ mA}) \leq 10 \%$ (measured in direction of surge current) No visible damage



Data sheet

	Characteristics	Test Methods/Description	Specifications							
M	Tensile strength	After gradually applying the force specified below and keeping the unit fixed for 10 seconds, the terminal shall be visually examined for any damage.	$ \Delta V/V (1 \text{ mA}) \leq 5 \%$ No break of solder joint, no wire break							
		<table border="1"> <thead> <tr> <th>Terminal diameter</th> <th>Force</th> </tr> </thead> <tbody> <tr> <td>0.5 mm</td> <td>5 N</td> </tr> <tr> <td>0.6 mm</td> <td>10 N</td> </tr> <tr> <td>0.8 mm</td> <td>10 N</td> </tr> <tr> <td>1.0 mm</td> <td>20 N</td> </tr> </tbody> </table>		Terminal diameter	Force	0.5 mm	5 N	0.6 mm	10 N	0.8 mm
Terminal diameter	Force									
0.5 mm	5 N									
0.6 mm	10 N									
0.8 mm	10 N									
1.0 mm	20 N									
E C H	Vibration	After repeatedly applying a single harmonic vibration according to the table below. Thereafter, the unit shall be visually examined. frequency range: 10 ... 55 Hz amplitude: 0.75 mm or 98 m/s ² duration: 6 h (3 x 2 h) pulse: sine wave	$ \Delta V/V (1 \text{ mA}) \leq 5 \%$ No visible damage							
A N I C A L	Solderability	After dipping the terminals to a depth of approximately 3 mm from the body in a soldering bath of 235°C for 5 seconds, the terminals shall be visually examined.	The inspection shall be carried out under adequate light with normal eyesight or with the assistance of a magnifier capable of giving a magnification of 4 times to 10 times. The dipped surface shall be covered with a smooth and bright solder coating with no more than small amounts of scattered imperfections such as pinholes or un-wetted or de-wetted areas. These imperfections shall not be concentrated in one area.							



Data sheet

	Characteristics	Test Methods/Description	Specifications
M E C H A N I C A L	Resistance to soldering heat	Each lead shall be dipped into a solder bath having a temperature of $260 \pm 5^{\circ}\text{C}$ to a point 2.0 to 2.5 mm from the body of the unit, be held there for 10 ± 1 s and then be stored at room temperature and normal humidity for 1 to 2 hours. The change of V_v and mechanical damages shall be examined.	$ \Delta V/V (1 \text{ mA}) \leq 5 \%$ No visible damage
	Electric strength	2500 V_{RMS} , 10 s The varistor is placed in a container holding 1.6 \pm 0.2 mm diameter metal balls such that only the terminations of the varistor are protruding. The specified voltage shall be applied between both terminals of the specimen connected together and the electrode inserted between the metal balls.	No breakdown

ISSUE DATE	22.05.02	ISSUE	a	PUBLISHER	KH PE VAR	PAGE	5/6
------------	----------	-------	---	-----------	-----------	------	-----



Data sheet

	Characteristics	Test Methods/Description	Specifications												
E N V I	Max. AC operating voltage	After being continuously applied the maximum allowable voltage at $85 \pm 2^\circ\text{C}$ for 1000 hours, the specimen shall be stored at room temperature and normal humidity for 1 to 2 hours. Thereafter, the change of V_v shall be measured.	$ \Delta V/V (1 \text{ mA}) \leq 10 \%$												
	Damp heat, steady state	The specimen shall be subjected to $40 \pm 2^\circ\text{C}$, 90 to 95 % r.H. for 56 days without load and then stored at room temperature and normal humidity for 1 to 2 hours. Thereafter, the change of V_v shall be measured.	$ \Delta V/V (1 \text{ mA}) \leq 10 \%$												
R O N M	Climatic sequence	The specimen shall be subjected to: a) dry heat at $+85^\circ\text{C}$, 16 h b) damp heat, 1st cycle: 55°C , 93 % r.H., 24 h c) cold, -40°C , 2 h d) damp heat, additional 5 cycles: 55°C , 93 % r.H., 24 h/cycle Then the specimen shall be stored at room temperature and normal humidity for 1 to 2 hours. Thereafter, the change of V_v shall be measured.	$ \Delta V/V (1 \text{ mA}) \leq 10 \%$												
E N T A L	Fast temperature cycling	The temperature cycle shown below shall be repeated 5 times. Then the specimen shall be stored at room temperature and normal humidity for 1 to 2 hours. The change of V_v and mechanical damage shall be examined. <table border="1" style="margin-left: auto; margin-right: auto;"> <thead> <tr> <th>Step</th> <th>Temperature ($^\circ\text{C}$)</th> <th>Period (min.)</th> </tr> </thead> <tbody> <tr> <td>1</td> <td>-40 ± 3</td> <td>30 ± 3</td> </tr> <tr> <td>2</td> <td>transition time</td> <td>$< 10 \text{ s}$</td> </tr> <tr> <td>3</td> <td>85 ± 2</td> <td>30 ± 3</td> </tr> </tbody> </table>	Step	Temperature ($^\circ\text{C}$)	Period (min.)	1	-40 ± 3	30 ± 3	2	transition time	$< 10 \text{ s}$	3	85 ± 2	30 ± 3	$ \Delta V/V (1 \text{ mA}) \leq 5 \%$ No visible damage
Step	Temperature ($^\circ\text{C}$)	Period (min.)													
1	-40 ± 3	30 ± 3													
2	transition time	$< 10 \text{ s}$													
3	85 ± 2	30 ± 3													

Note: More details can be found in the data book 'SIOV Metal Oxide Varistors', Ordering No. EPC: 62002-7600

© EPCOS AG 2002. Reproduction, publication and dissemination of this data sheet, enclosures hereto and the information contained therein without EPCOS' prior express consent is prohibited.

Purchase orders are subject to the General Conditions for the Supply of Products and Services of the Electrical and Electronics Industry recommended by the ZVEI (German Electrical and Electronic Manufacturers' Association), unless otherwise agreed.

ISSUE DATE	22.05.02	ISSUE	a	PUBLISHER	KH PE VAR	PAGE	6/6
------------	----------	-------	---	-----------	-----------	------	-----

Компания «Океан Электроники» предлагает заключение долгосрочных отношений при поставках импортных электронных компонентов на взаимовыгодных условиях!

Наши преимущества:

- Поставка оригинальных импортных электронных компонентов напрямую с производств Америки, Европы и Азии, а так же с крупнейших складов мира;
- Широкая линейка поставок активных и пассивных импортных электронных компонентов (более 30 млн. наименований);
- Поставка сложных, дефицитных, либо снятых с производства позиций;
- Оперативные сроки поставки под заказ (от 5 рабочих дней);
- Экспресс доставка в любую точку России;
- Помощь Конструкторского Отдела и консультации квалифицированных инженеров;
- Техническая поддержка проекта, помощь в подборе аналогов, поставка прототипов;
- Поставка электронных компонентов под контролем ВП;
- Система менеджмента качества сертифицирована по Международному стандарту ISO 9001;
- При необходимости вся продукция военного и аэрокосмического назначения проходит испытания и сертификацию в лаборатории (по согласованию с заказчиком);
- Поставка специализированных компонентов военного и аэрокосмического уровня качества (Xilinx, Altera, Analog Devices, Intersil, Interpoint, Microsemi, Actel, Aeroflex, Peregrine, VPT, Syfer, Eurofarad, Texas Instruments, MS Kennedy, Miteq, Cobham, E2V, MA-COM, Hittite, Mini-Circuits, General Dynamics и др.);

Компания «Океан Электроники» является официальным дистрибьютором и эксклюзивным представителем в России одного из крупнейших производителей разъемов военного и аэрокосмического назначения «JONHON», а так же официальным дистрибьютором и эксклюзивным представителем в России производителя высокотехнологичных и надежных решений для передачи СВЧ сигналов «FORSTAR».



JONHON

«JONHON» (основан в 1970 г.)

Разъемы специального, военного и аэрокосмического назначения:

(Применяются в военной, авиационной, аэрокосмической, морской, железнодорожной, горно- и нефтедобывающей отраслях промышленности)

«FORSTAR» (основан в 1998 г.)

ВЧ соединители, коаксиальные кабели, кабельные сборки и микроволновые компоненты:

(Применяются в телекоммуникациях гражданского и специального назначения, в средствах связи, РЛС, а так же военной, авиационной и аэрокосмической отраслях промышленности).



Телефон: 8 (812) 309-75-97 (многоканальный)

Факс: 8 (812) 320-03-32

Электронная почта: ocean@oceanchips.ru

Web: <http://oceanchips.ru/>

Адрес: 198099, г. Санкт-Петербург, ул. Калинина, д. 2, корп. 4, лит. А