

IB IL 24 PWR IN/2F-DF IB IL 24 PWR IN/2F-DF-PAC

Inline Power Terminal
With Fuse and Diagnostics

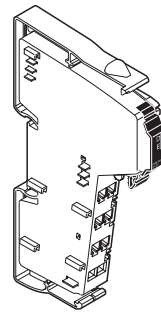

Data Sheet

06/2004

7047A001



The IB IL 24 PWR IN/2F-DF and IB IL 24 PWR IN/2F-DF-PAC only differ in the scope of supply (see "Ordering Data" on page 11). Their function and technical data are identical.

For greater clarity, the Order Designation IB IL 24 PWR IN/2F-DF is used throughout this document.



This data sheet is only valid in association with the IB IL SYS PRO UM E user manual or the Inline system manual for your bus system.

Function

The terminal is designed for use within an Inline station.

The terminal supplies 24 V supply voltage to the main circuit (U_M) and automatically provides the 24 V supply voltage to the segment circuit (U_S).

The terminal has protection against polarity reversal and surge voltage.

The internal fuse protects the main and segment circuit.

This terminal has an LED for bus diagnostics and occupies two input data bits, which are used to indicate the presence of the supply voltage and the state of the fuse.

Features

- Supply of the 24 V main voltage U_M
- Provision of the 24 V segment voltage U_S
- Main and segment circuit protected by an internal fuse
- Diagnostic indicators
- This terminal is an INTERBUS device.

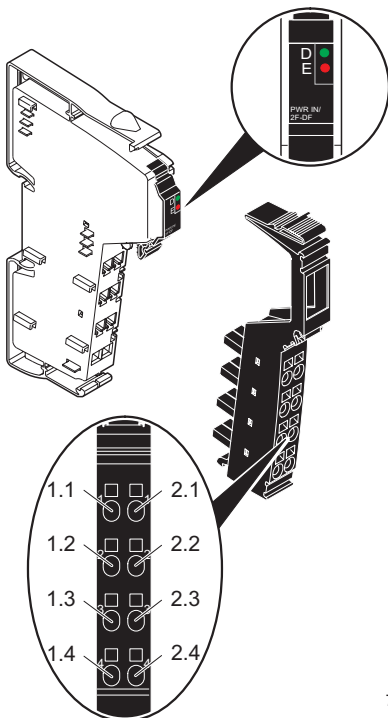

Figure 1 IB IL 24 PWR IN/2F-DF with appropriate connector

Function Identification

Black

7047A002

Local Diagnostic Indicators

Des.	Color	Meaning
D	Green	Bus Diagnostics
		ON: INTERBUS is active
		Flashing:
		0,5 Hz Communications power present, INTERBUS not active
		2 Hz I/O error, if the fuse is blown or missing.
		4 Hz Communications power present, local bus error
OFF: Communications power not present, INTERBUS not active		
E	Red	Fuse
		OFF: Fuse OK
		ON: Fuse has blown



If the fuse is missing or has blown, an I/O error message is sent to the higher-level control or computer system.



A blown or missing fuse is indicated by both LED diagnostic indicators. The red E LED lights up and the green D LED flashes at 2 Hz.

Terminal Point Assignment

Terminal Point	Assignment
1.1, 2.1	Measuring points for the segment circuit U_S
1.2, 2.2	Supply points for the main circuit U_M (+24 V) These terminal points are connected with each other and with the potential jumper of the main supply U_M via the fuse. The potential jumpers of the main circuit U_M and the segment circuit U_S (both protected) have a combined current carrying capacity of 6.3 A.
1.3, 2.3	Ground contact (GND) for main and segment circuit The reference potential is directly routed to the potential jumper and is, at the same time, ground reference for the main and segment voltages.
1.4, 2.4	FE connection The contacts are directly connected with the potential jumper and the FE springs on the bottom of the housing. The terminal is grounded when it is snapped onto a grounded DIN rail.
	Terminal points 1.2 and 1.3 are connected with a capacitor to FE.

**Observe the current carrying capacity**

The maximum total current flowing through the potential jumpers must not exceed 6.3 A.

Internal Circuit Diagram

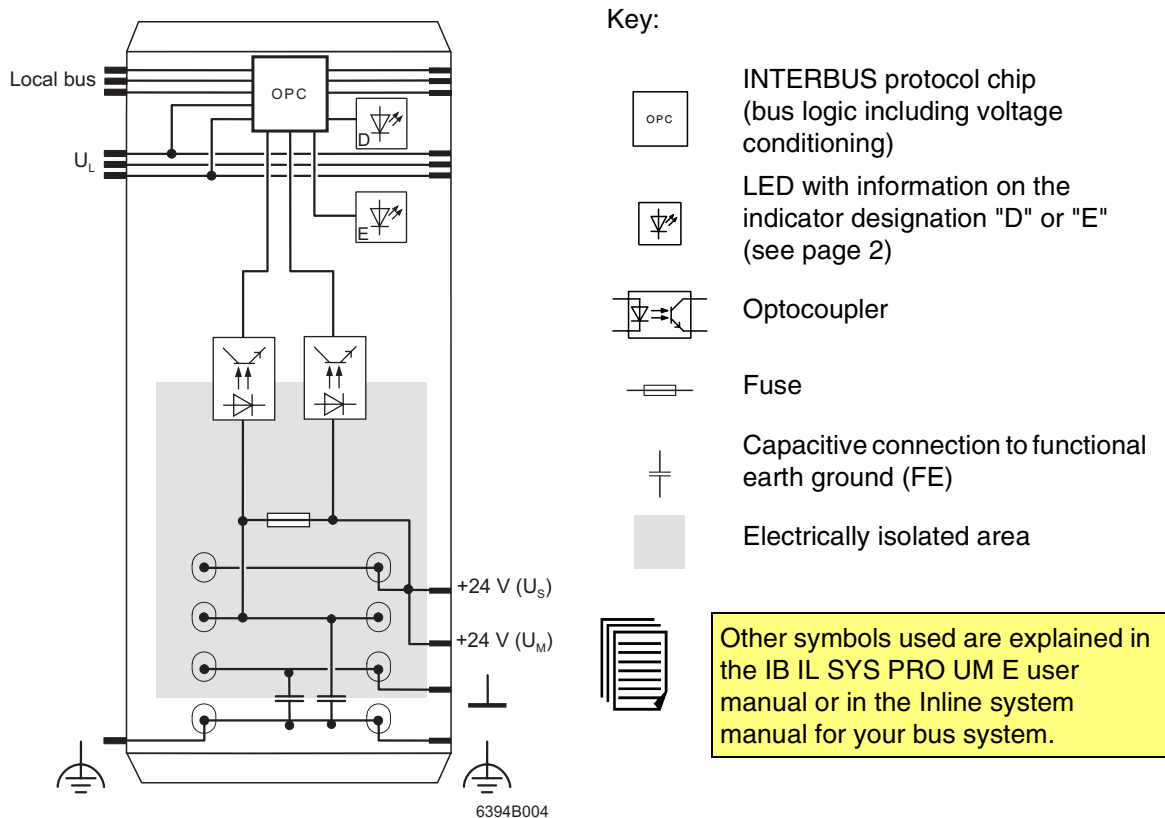

Figure 2 Internal wiring of the terminal points

Connection Example



The 24 V supply in the main and segment circuit is protected by the internal fuse.



Most I/O terminals are supplied from the segment circuit.

This voltage is automatically provided at the IB IL 24 PWR IN/2F-DF terminal.

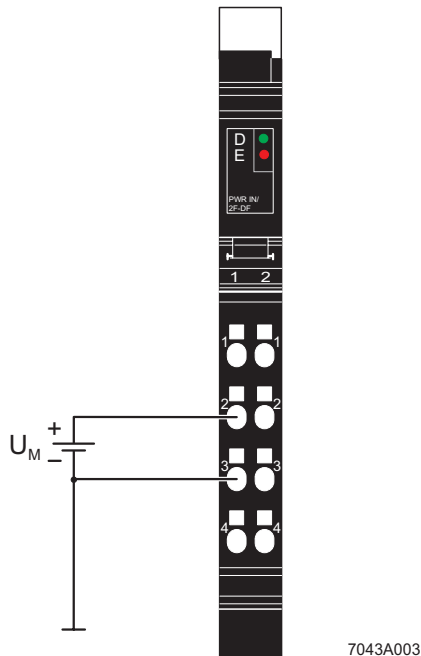

Figure 3 Typical connection of the supply voltage U_M



To ensure maximum current carrying capacity, use a power connector to connect the cables (see page 11). In these connectors, the adjacent terminal points 1.2 and 2.2, and 1.3 and 2.3 are jumpered internally.

Programming Data/ Configuration Data

INTERBUS

ID code	BE _{hex} (190 _{dec})
Length code	C2 _{hex}
Process data channel	2 bits
Input address area	2 bits
Output address area	0 bits
Parameter channel (PCP)	0 bits
Register length (bus)	2 bits

Other Bus Systems



For the programming data of other bus systems, please refer to the appropriate electronic device data sheet (GSD, EDS). Up-to-date information can be found on the Internet at www.phoenixcontact.com.

Process Data

Assignment of the IN Process Data Words





The IN process data only maps the status of the fuse and the main voltage.

(Byte.bit) view		0.1	0.0
Assignment	Main voltage U_M is present, fuse is OK	1	1
	Main power U_M present, fuse blown or missing	1	0
	Main power U_M not present, fuse blown or missing	0	0



For the assignment of the illustrated (byte.bit) view to your control or computer system, please refer to the DB GB IBS SYS ADDRESS data sheet, Order No. 90 00 99 0.

Technical Data

General Data	
Order Designation	Order No.
	IB IL 24 PWR IN/2F-DF 28 63 78 2 IB IL 24 PWR IN/2F-DF-PAC 28 63 77 9
Housing dimensions (width x height x depth)	12.2 mm x 120 mm x 71.5 mm (0.480 x 4.724 x 2.815 in.)
Weight	44 g (without connectors)
Operating mode	Process data mode with 2 bits
Transmission speed	500 kbps
Permissible temperature (operation)	-25°C to +55°C (-13°F to +131°F)
Permissible temperature (storage/transport)	-25°C to +85°C (-136°F to +185°F)
Permissible humidity (operation)	75% on average, 85% occasionally
	In the range from -25°C to +55°C (-13°F to +131°F) appropriate measures against increased humidity (> 85%) must be taken.
Permissible humidity (storage/transport)	75% on average, 85% occasionally
	For a short period, slight condensation may appear on the outside of the housing if, for example, the terminal is brought into a closed room from a vehicle.
Permissible air pressure (operation)	80 kPa to 106 kPa (up to 2,000 m [6,562 ft.] above sea level)
Permissible air pressure (storage/transport)	70 kPa to 106 kPa (up to 3,000 m [9,843 ft.] above sea level)
Degree of protection	IP20 according to IEC 60529
Class of protection	Class 3 according to VDE 0106, IEC 60536
Interface	
Local bus interface	Through data routing

Power Consumption	
Communications power U_L	7.5 V DC
Current consumption at U_L	25 mA, maximum
Power consumption at U_L	0.19 W, maximum
Main voltage U_M	24 V DC (nominal value)
Nominal current consumption at U_M	4.0 A (nominal value)

Supply of the Module Electronics Through the Bus Terminal (U_L)	
Connection method	Through potential routing

24 V I/O Supply (Main Circuit U_M)		
Connection	+24 V Ground (GND)	Terminal points 1.2 and 2.2 Terminal points 1.3 and 2.3
Rated value		24 V DC
Tolerance		-15% / +20%
AC component		5%
Permissible range		19.2 V to 30 V
Permissible current		6.3 A, maximum
Voltage supply requirements		The power terminal must be supplied from a new power supply unit to create an electrically isolated area. Protect the 24 V power supply with an external fuse.
	The power supply unit must be able to supply 4 times (400%) the nominal current of the external fuse.	

Permissible Total Current in the Potential Jumpers of the Main and Segment Circuit/ Nominal Current of the Terminal		
Permissible total current in the potential jumpers	6.3 A	
Nominal current of the terminal	4.0 A	
Tolerance	+10%	
	The terminal is delivered with a 6.3 A slow-blow fuse. With an increased total current in the potential jumpers U_M and U_S the user must protect the circuit by using higher rated fuses. Please note the information for the selection of fuses given on page 8.	

Power Dissipation

Formula to Calculate the Power Dissipation of the Electronics

$$P_{TOT} = 0.180 \text{ W} + I_M^2 \times R_F$$

Where

P_{TOT} Total power dissipation in the terminal

I_M Load current in the main circuit

R_F Resistance of the fuse

The resistance of fuse R_F for a 6.3 AT fuse is approximately 12 mΩ.

The power dissipation of the electronics for a theoretical maximum current of 6.3 A (nominal current = 4.0 A) is calculated as follows:

$$\begin{aligned} P_{TOT} &= 0.18 \text{ W} + 39.69 \text{ A}^2 \times 0.012 \text{ } \Omega \\ &= 0.66 \text{ W} \end{aligned}$$

Power Dissipation of the Housing (P_{HOU})

$P_{HOU} = 0.7 \text{ W}$ in the total permissible ambient temperature range

Typical Power Dissipation of the Electronics Depending on the Load Current in the Main Circuit

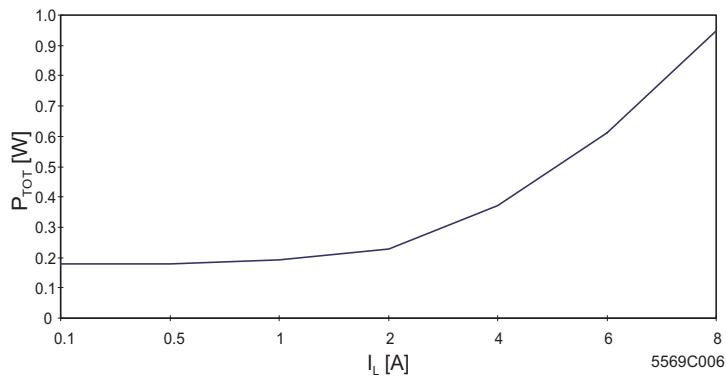





P [W] Power dissipation in W
 I_L [A] Load current in the main circuit in A

This test was carried out with a 6.3 AT fuse.

Derating of the Load Current in the Segment Circuit

No derating

Safety Equipment	
Overload/short circuit in the main circuit and in the segment circuit	Fuse 5 x 20 with 6.3 A, slow-blow
	Fuses with other values can also be used. The maximum fuse value may not exceed 6.3 A.
	Note for the selection of fuses: Only use slow-blow fuses for fuses with higher rating than 2 A.
Surge voltage	Yes, suppressor diode for voltage limitation between terminal points 1.1 and 1.3, and terminal points 1.2 and 1.3
Polarity reversal	Yes; diode connected in parallel as protection against polarity reversal
	The power supply unit must be able to supply 4 times (400%) the nominal current of the internal fuse.

Electrical Isolation	
	To provide electrical isolation between the logic level and the I/O area, it is necessary to supply these areas via the bus terminal or via the bus terminal and a power terminal from separate power supply units. Interconnection of the power supply units in the 24 V area is not permitted. Please also pay attention to GND/PE connections on the power supply units (see also user manual).

Common Potentials	
The 24 V main voltage, 24 V segment voltage, and GND have the same potential. FE is a separate potential area.	
Separate Potentials in the System Consisting of Bus Terminal/Power Terminal and I/O Terminal	
- Test Distance	- Test Voltage
5 V supply incoming remote bus / 7.5 V supply (bus logic)	500 V AC, 50 Hz, 1 min.
5 V supply outgoing remote bus / 7.5 V supply (bus logic)	500 V AC, 50 Hz, 1 min.
7.5 V supply (bus logic)/24 V supply (I/O)	500 V AC, 50 Hz, 1 min.
24 V supply (I/O)/functional earth ground	500 V AC, 50 Hz, 1 min.

Error Messages to the Superior Control System

I/O error message if fuse blown or missing

Ordering Data

Description	Order Designation	Order No.
Power terminal with fuse and diagnostics; including connectors and labeling field	IB IL 24 PWR IN/2F-DF-PAC	28 63 77 9
Power terminal with fuse and diagnostics	IB IL 24 PWR IN/2F-DF	28 63 78 2
 <p>One of the listed connectors is needed for the complete fitting of the IB IL 24 PWR IN/2F-DF terminal.</p>		
Connector for voltage supply (black, with color print); pack of 10	IB IL SCN-PWR IN-CP	27 27 63 7
Connector for voltage supply (black, w/o color print); pack of 10	IB IL SCN-PWR IN	27 27 46 2
Fuse	SI 5 x 20 6,300 A T	50 30 51 2
"Configuring and Installing the INTERBUS Inline Product Range" user manual	IB IL SYS PRO UM E	27 43 04 8



Make sure you always use the latest documentation. It can be downloaded at www.phoenixcontact.com.

Phoenix Contact GmbH & Co. KG
 Flachsmarktstr. 8
 32825 Blomberg
 Germany



+ 49 - (0) 52 35 - 3-00



+ 49 - (0) 52 35 - 3-4 12 00



www.phoenixcontact.com



Worldwide Locations:

www.phoenixcontact.com/salesnetwork

Компания «Океан Электроники» предлагает заключение долгосрочных отношений при поставках импортных электронных компонентов на взаимовыгодных условиях!

Наши преимущества:

- Поставка оригинальных импортных электронных компонентов напрямую с производств Америки, Европы и Азии, а так же с крупнейших складов мира;
- Широкая линейка поставок активных и пассивных импортных электронных компонентов (более 30 млн. наименований);
- Поставка сложных, дефицитных, либо снятых с производства позиций;
- Оперативные сроки поставки под заказ (от 5 рабочих дней);
- Экспресс доставка в любую точку России;
- Помощь Конструкторского Отдела и консультации квалифицированных инженеров;
- Техническая поддержка проекта, помощь в подборе аналогов, поставка прототипов;
- Поставка электронных компонентов под контролем ВП;
- Система менеджмента качества сертифицирована по Международному стандарту ISO 9001;
- При необходимости вся продукция военного и аэрокосмического назначения проходит испытания и сертификацию в лаборатории (по согласованию с заказчиком);
- Поставка специализированных компонентов военного и аэрокосмического уровня качества (Xilinx, Altera, Analog Devices, Intersil, Interpoint, Microsemi, Actel, Aeroflex, Peregrine, VPT, Syfer, Eurofarad, Texas Instruments, MS Kennedy, Miteq, Cobham, E2V, MA-COM, Hittite, Mini-Circuits, General Dynamics и др.);

Компания «Океан Электроники» является официальным дистрибьютором и эксклюзивным представителем в России одного из крупнейших производителей разъемов военного и аэрокосмического назначения «JONHON», а так же официальным дистрибьютором и эксклюзивным представителем в России производителя высокотехнологичных и надежных решений для передачи СВЧ сигналов «FORSTAR».



JONHON

«JONHON» (основан в 1970 г.)

Разъемы специального, военного и аэрокосмического назначения:

(Применяются в военной, авиационной, аэрокосмической, морской, железнодорожной, горно- и нефтедобывающей отраслях промышленности)

«FORSTAR» (основан в 1998 г.)

ВЧ соединители, коаксиальные кабели,
кабельные сборки и микроволновые компоненты:

(Применяются в телекоммуникациях гражданского и специального назначения, в средствах связи, РЛС, а так же военной, авиационной и аэрокосмической отраслях промышленности).



Телефон: 8 (812) 309-75-97 (многоканальный)

Факс: 8 (812) 320-03-32

Электронная почта: ocean@oceanchips.ru

Web: <http://oceanchips.ru/>

Адрес: 198099, г. Санкт-Петербург, ул. Калинина, д. 2, корп. 4, лит. А