

# TS1105/06/09 Current Sense Amplifier EVB User's Guide

The TS1105, TS1106, and TS1109 combine a high-side current sense amplifier (CSA) with a buffered output featuring an adjustable bias. The TS1109 bidirectional CSA buffered output uses a bipolar scheme with respect to the bias voltage, while the TS1106 bidirectional CSA buffered output uses a unipolar scheme.

The TS1105/06/09 CSA requires a very low 0.68  $\mu\text{A}$  supply current, while the CSA buffered output requires a very low nominal supply current of 0.76  $\mu\text{A}$ . These CSAs are designed for high precision current measurements as the TS1109 combines a 1% gain error(MAX) with a 150  $\mu\text{V}$  VOS(MAX) while the TS1105/06 combine a 0.6% gain error(MAX) with a 100  $\mu\text{V}$  VOS(MAX). The inverting terminal of the CSA output buffer, FILT, is also made accessible so that a RC Filter can be connected to reduce noise.

The TS1105/06/09 is fully specified to operate over the  $-40\text{ }^{\circ}\text{C}$  to  $+85\text{ }^{\circ}\text{C}$  temperature range and is available in a low-profile, thermally-enhanced, 8-pin 3 x 3 mm TDFN package with an exposed back-side paddle.

## KEY FEATURES

- $R_{\text{SENSE}}$ : 50 m $\Omega$   $\pm$  0.5%
- Adjustable Bias for CSA Buffer
- Compatible for Both Gain Options
  - 20 V/V
  - 200 V/V

## ORDERING INFORMATION

- TS1105-20DB
- TS1105-200DB
- TS1106-20DB
- TS1106-200DB
- TS1109-20DB
- TS1109-200DB

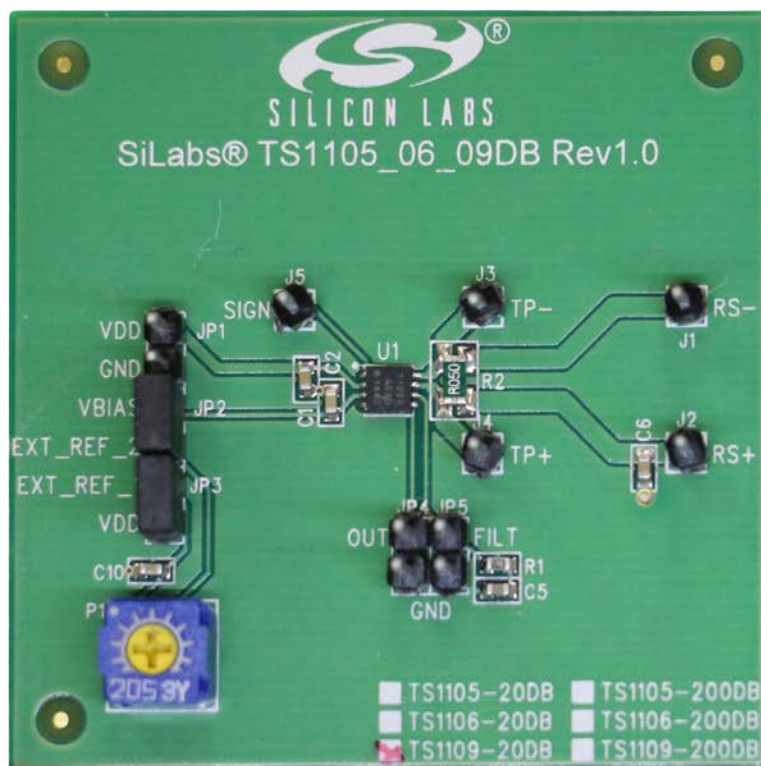

## 1. Description

The TS1105/06/09 Evaluation Board is intended for evaluation of the current sense amplifier plus the buffered output with adjustable bias. The evaluation board includes a variable reference scheme so that the bias voltage of the CSA buffered output can be adjusted with respect to the VDD voltage. The jumpers, JP2 and JP3, can be connected so that the included potentiometer can be used to adjust the bias voltage. The Quick Start Procedure details adjustment of the bias voltage for the CSA buffered output and measurement of the output voltage for a given load.

**Table 1.1. Component List**

Designation	Quantity	Description
U1	1	TS1105-20, TS1105-200 TS1106-20, TS1106-200 TS1109-20, TS1109-200
R1	1	4.02 k $\Omega$ $\pm$ 1%, 1/16 W (0603)
R2	1	0.05 $\Omega$ $\pm$ 0.5%, 1/2 W (1206)
C1, C6	2	1 $\mu$ F $\pm$ 10%, 10 V (0603)
C2, C10	2	0.1 $\mu$ F $\pm$ 10%, 10 V (0603)
C5	1	0.47 $\mu$ F $\pm$ 10%, 10 V (0603)
J1, J2, J3, J4	4	Header 1 x 1
J5 (TS1106 and TS1109 Only)	1	Header 1 x 1
JP1, JP2, JP3, JP4, JP5	5	Header 1 x 2
JS1, JS2	2	Jumper Shunt

## 2. Quick Start Procedure

### Required Equipment

- 3 V Power Supply or 3 V Battery
- 2 Digital Multimeters
  - 1 ammeter
  - 1 voltmeter
- Potentiometer

To use the TS1105/06/09 evaluation board, perform the following steps:

1. Configure JP3 so that the Jumper Shunt is connecting VDD to EXT\_REF\_1, and configure JP2 so that the jumper shunt is connecting V<sub>BIAS</sub> to EXT\_REF\_2.
2. Connect the 3 V power source to RS+ and VDD.
3. Use the voltmeter to measure the V<sub>BIAS</sub> voltage, and adjust P1 potentiometer so that V<sub>BIAS</sub> is 1.5 V.
4. Connect the voltmeter to measure V<sub>OUT</sub>. With no load connected, V<sub>OUT</sub> should be equal to V<sub>BIAS</sub>. The expression for the V<sub>OUT</sub> output voltage is defined by the following equations:

$$V_{OUT} = V_{VBIAS} - (GAIN \times R_{SENSE} \times |i_{SENSE}|)$$

**Equation 1. TS1105 and TS1106 Output Voltage**

$$V_{OUT} = V_{VBIAS} - (GAIN \times R_{SENSE} \times \pm i_{SENSE})$$

**Equation 2. TS1109 Output Voltage**

5. Connect an ammeter in series from RS– to a potentiometer. Adjust the POT until the ammeter reads:
  - TS1105/06/09-20: 500 mA
  - TS1105/06/09-200: 50 mA

V<sub>OUT</sub> should equal 1 V, and SIGN should be HIGH.

6. TS1106 and TS1109 Only: To evaluate the bidirectional functionality and observe the unipolar or bipolar CSA buffered output scheme, disconnect the 3 V power supply from RS+ and VDD, as well as the POT connected to RS–. Reconfigure the 3 V power source by connecting it to RS– and VDD. Connect the ammeter in series from RS+ to the potentiometer. Adjust the POT so that the ammeter reads the correct ILOAD value for the given part number. The SIGN output will be LOW. Confirm that the output voltage matches with the given part number.

**Table 2.1. Output Voltages by Part Number**

Part Number	I <sub>LOAD</sub>	V <sub>OUT</sub>
TS1106-20	500 mA	1 V
TS1106-200	50 mA	
TS1109-20	500 mA	2 V
TS1109-200	50 mA	

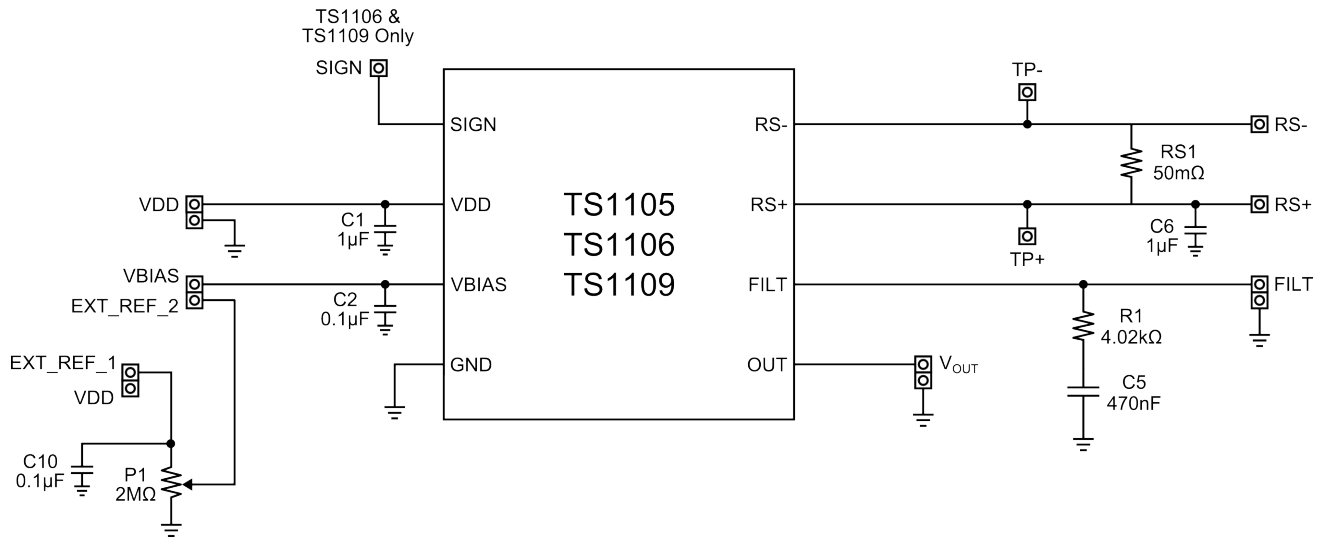

Figure 2.1. TS1105/06/09DB Circuit Schematic



Smart.  
Connected.  
Energy-Friendly



**Products**  
[www.silabs.com/products](http://www.silabs.com/products)



**Quality**  
[www.silabs.com/quality](http://www.silabs.com/quality)



**Support and Community**  
[community.silabs.com](http://community.silabs.com)

#### Disclaimer

Silicon Laboratories intends to provide customers with the latest, accurate, and in-depth documentation of all peripherals and modules available for system and software implementers using or intending to use the Silicon Laboratories products. Characterization data, available modules and peripherals, memory sizes and memory addresses refer to each specific device, and "Typical" parameters provided can and do vary in different applications. Application examples described herein are for illustrative purposes only. Silicon Laboratories reserves the right to make changes without further notice and limitation to product information, specifications, and descriptions herein, and does not give warranties as to the accuracy or completeness of the included information. Silicon Laboratories shall have no liability for the consequences of use of the information supplied herein. This document does not imply or express copyright licenses granted hereunder to design or fabricate any integrated circuits. The products must not be used within any Life Support System without the specific written consent of Silicon Laboratories. A "Life Support System" is any product or system intended to support or sustain life and/or health, which, if it fails, can be reasonably expected to result in significant personal injury or death. Silicon Laboratories products are generally not intended for military applications. Silicon Laboratories products shall under no circumstances be used in weapons of mass destruction including (but not limited to) nuclear, biological or chemical weapons, or missiles capable of delivering such weapons.

#### Trademark Information

Silicon Laboratories Inc., Silicon Laboratories, Silicon Labs, SiLabs and the Silicon Labs logo, CMEMS®, EFM, EFM32, EFR, Energy Micro, Energy Micro logo and combinations thereof, "the world's most energy friendly microcontrollers", Ember®, EZLink®, EZMac®, EZRadio®, EZRadioPRO®, DSPLL®, ISOmodem®, Precision32®, ProSLIC®, SiPHY®, USBXpress® and others are trademarks or registered trademarks of Silicon Laboratories Inc. ARM, CORTEX, Cortex-M3 and THUMB are trademarks or registered trademarks of ARM Holdings. Keil is a registered trademark of ARM Limited. All other products or brand names mentioned herein are trademarks of their respective holders.



Silicon Laboratories Inc.  
400 West Cesar Chavez  
Austin, TX 78701  
USA

<http://www.silabs.com>

Компания «Океан Электроники» предлагает заключение долгосрочных отношений при поставках импортных электронных компонентов на взаимовыгодных условиях!

Наши преимущества:

- Поставка оригинальных импортных электронных компонентов напрямую с производств Америки, Европы и Азии, а так же с крупнейших складов мира;
- Широкая линейка поставок активных и пассивных импортных электронных компонентов (более 30 млн. наименований);
- Поставка сложных, дефицитных, либо снятых с производства позиций;
- Оперативные сроки поставки под заказ (от 5 рабочих дней);
- Экспресс доставка в любую точку России;
- Помощь Конструкторского Отдела и консультации квалифицированных инженеров;
- Техническая поддержка проекта, помощь в подборе аналогов, поставка прототипов;
- Поставка электронных компонентов под контролем ВП;
- Система менеджмента качества сертифицирована по Международному стандарту ISO 9001;
- При необходимости вся продукция военного и аэрокосмического назначения проходит испытания и сертификацию в лаборатории (по согласованию с заказчиком);
- Поставка специализированных компонентов военного и аэрокосмического уровня качества (Xilinx, Altera, Analog Devices, Intersil, Interpoint, Microsemi, Actel, Aeroflex, Peregrine, VPT, Syfer, Eurofarad, Texas Instruments, MS Kennedy, Miteq, Cobham, E2V, MA-COM, Hittite, Mini-Circuits, General Dynamics и др.);

Компания «Океан Электроники» является официальным дистрибьютором и эксклюзивным представителем в России одного из крупнейших производителей разъемов военного и аэрокосмического назначения «JONHON», а так же официальным дистрибьютором и эксклюзивным представителем в России производителя высокотехнологичных и надежных решений для передачи СВЧ сигналов «FORSTAR».



## JONHON

«JONHON» (основан в 1970 г.)

Разъемы специального, военного и аэрокосмического назначения:

(Применяются в военной, авиационной, аэрокосмической, морской, железнодорожной, горно- и нефтедобывающей отраслях промышленности)

«FORSTAR» (основан в 1998 г.)

ВЧ соединители, коаксиальные кабели, кабельные сборки и микроволновые компоненты:

(Применяются в телекоммуникациях гражданского и специального назначения, в средствах связи, РЛС, а так же военной, авиационной и аэрокосмической отраслях промышленности).



Телефон: 8 (812) 309-75-97 (многоканальный)

Факс: 8 (812) 320-03-32

Электронная почта: [ocean@oceanchips.ru](mailto:ocean@oceanchips.ru)

Web: <http://oceanchips.ru/>

Адрес: 198099, г. Санкт-Петербург, ул. Калинина, д. 2, корп. 4, лит. А