



**USB2504/
USB2504A**



Integrated USB 2.0 Compatible 4-Port Hub

PRODUCT FEATURES

Datasheet

- Integrated USB 2.0 Compatible 4-Port Hub
 - 4 Transaction Translators for highest performance
 - High-Speed (480Mbps/s), Full-Speed (12Mbps/s) and Low-Speed (1.5Mbps/s) compatible
 - Full power management with per port or ganged, selectable power control
 - Detects Bus-Power/Self-Power source and changes mode automatically
- Complete USB Specification 2.0 Compatibility
 - Includes USB 2.0 Transceivers
- VID/PID/DID, and Port Configuration for Hub via:
 - Single Serial I²C EEPROM
 - SMBus Slave Port
- Default VID/PID/DID, allows functionality when configuration EEPROM is absent
- Hardware Strapping options allow for configuration without an external EEPROM or SMBus Host
- On-Board 24MHz Crystal Driver Circuit or 24 MHz external clock driver
- Internal PLL for 480MHz USB 2.0 Sampling
- Internal 1.8V Linear Voltage Regulator
- Integrated USB termination and Pull-up/Pull-down resistors
- Internal Short Circuit protection of USB differential signal pins
- 1.8 Volt Low Power Core Operation
- 3.3 Volt I/O with 5V Input Tolerance
- 64-Pin TQFP lead-free RoHS compliant package

ORDER NUMBERS:**USB2504/USB2504A-JT FOR 64 PIN TQFP LEAD-FREE ROHS COMPLIANT PACKAGE**

80 ARKAY DRIVE, HAUPPAUGE, NY 11788 (631) 435-6000, FAX (631) 273-3123

Copyright © 2007 SMSC or its subsidiaries. All rights reserved.

Circuit diagrams and other information relating to SMSC products are included as a means of illustrating typical applications. Consequently, complete information sufficient for construction purposes is not necessarily given. Although the information has been checked and is believed to be accurate, no responsibility is assumed for inaccuracies. SMSC reserves the right to make changes to specifications and product descriptions at any time without notice. Contact your local SMSC sales office to obtain the latest specifications before placing your product order. The provision of this information does not convey to the purchaser of the described semiconductor devices any licenses under any patent rights or other intellectual property rights of SMSC or others. All sales are expressly conditional on your agreement to the terms and conditions of the most recently dated version of SMSC's standard Terms of Sale Agreement dated before the date of your order (the "Terms of Sale Agreement"). The product may contain design defects or errors known as anomalies which may cause the product's functions to deviate from published specifications. Anomaly sheets are available upon request. SMSC products are not designed, intended, authorized or warranted for use in any life support or other application where product failure could cause or contribute to personal injury or severe property damage. Any and all such uses without prior written approval of an Officer of SMSC and further testing and/or modification will be fully at the risk of the customer. Copies of this document or other SMSC literature, as well as the Terms of Sale Agreement, may be obtained by visiting SMSC's website at <http://www.smSC.com>. SMSC is a registered trademark of Standard Microsystems Corporation ("SMSC"). Product names and company names are the trademarks of their respective holders.

SMSC DISCLAIMS AND EXCLUDES ANY AND ALL WARRANTIES, INCLUDING WITHOUT LIMITATION ANY AND ALL IMPLIED WARRANTIES OF MERCHANTABILITY, FITNESS FOR A PARTICULAR PURPOSE, TITLE, AND AGAINST INFRINGEMENT AND THE LIKE, AND ANY AND ALL WARRANTIES ARISING FROM ANY COURSE OF DEALING OR USAGE OF TRADE. IN NO EVENT SHALL SMSC BE LIABLE FOR ANY DIRECT, INCIDENTAL, INDIRECT, SPECIAL, PUNITIVE, OR CONSEQUENTIAL DAMAGES; OR FOR LOST DATA, PROFITS, SAVINGS OR REVENUES OF ANY KIND; REGARDLESS OF THE FORM OF ACTION, WHETHER BASED ON CONTRACT; TORT; NEGLIGENCE OF SMSC OR OTHERS; STRICT LIABILITY; BREACH OF WARRANTY; OR OTHERWISE; WHETHER OR NOT ANY REMEDY OF BUYER IS HELD TO HAVE FAILED OF ITS ESSENTIAL PURPOSE, AND WHETHER OR NOT SMSC HAS BEEN ADVISED OF THE POSSIBILITY OF SUCH DAMAGES.

Table of Contents

Chapter 1	General Description	7
1.1	OEM Selectable Features.....	7
Chapter 2	Pin Table 4-Port	8
Chapter 3	Pin Configuration 4-Port Hub	9
Chapter 4	4-Port Hub Block Diagram	10
Chapter 5	Functional Block Description	16
5.1	4-Port Hub.....	16
5.1.1	Hub Configuration Options.....	16
5.1.2	VBus Detect.....	19
5.2	EEPROM Interface.....	19
5.2.1	I2C EEPROM.....	19
5.2.2	In-Circuit EEPROM Programming.....	20
5.2.3	EEPROM DATA.....	20
5.3	SMBus Slave Interface.....	25
5.3.1	Bus Protocols.....	25
5.3.2	Invalid Protocol Response Behavior.....	26
5.3.3	General Call Address Response.....	26
5.3.4	Slave Device Time-Out.....	27
5.3.5	Stretching the SCLK Signal.....	27
5.3.6	SMBus Timing.....	27
5.3.7	Bus Reset Sequence.....	27
5.3.8	SMBus Alert Response Address.....	27
5.3.9	Internal SMBus Memory Register Set.....	27
5.4	Default Configuration Option:.....	33
5.5	Default Strapping Options:.....	33
5.6	Reset.....	34
5.6.1	External Hardware RESET_N.....	34
5.6.2	USB Bus Reset.....	37
Chapter 6	Backward Compatibility to the USB20H04	39
6.1	Internal 1.8V regulator.....	39
6.2	Configuration by Internal Defaults.....	39
6.3	Configuration by SMBus.....	39
6.4	PRTPWR_POL.....	39
Chapter 7	XNOR Test	40
Chapter 8	DC Parameters	41
8.1	Maximum Guaranteed Ratings.....	41
8.2	Recommended Operating Conditions.....	42
Chapter 9	AC Specifications	45
9.1	Oscillator/Clock.....	45
9.1.1	SMBus Interface:.....	45
9.1.2	I2C EEPROM:.....	45
9.1.3	USB 2.0.....	45

Chapter 10 Package Outline	46
---	-----------

Datasheet

List of Figures

Figure 3.1	4-Port 64 Pin TQFP	9
Figure 4.1	4-Port Block Diagram	10
Figure 5.1	LED Strapping Option	34
Figure 5.2	Reset_N Timing for Default/Strap Option Mode	35
Figure 5.3	Reset_N Timing for EEPROM Mode	36
Figure 5.4	Reset_N Timing for SMBus Mode	37
Figure 10.1	64 Pin TQFP Package Outline (10x10x1.4 mm body - 2 mm footprint)	46

List of Tables

Table 2.1	4-Port Pin Table for 64-TQFP	8
Table 4.1	4-Port Hub Pin Descriptions	10
Table 4.2	SMBus or EEPROM Interface Behavior	13
Table 4.3	Miscellaneous Pins	13
Table 4.4	Power, Ground, and No Connect.	14
Table 4.5	Buffer Type Descriptions	15
Table 5.1	User-Defined Descriptor Data	20
Table 5.2	SMBus Write Byte Protocol	26
Table 5.3	SMBus Read Byte Protocol	26
Table 5.4	SMBus Slave Interface Register Map	27
Table 5.5	Reset_N Timing for Default/Strap Option Mode	35
Table 5.6	Reset_N Timing for EEPROM Mode	36
Table 5.7	Reset_N Timing for SMBus Mode	37
Table 8.1	DC Electrical Characteristics	42
Table 10.1	64 Pin TQFP Package Parameters	46

Chapter 1 General Description

The SMSC 4-Port Hub is fully compliant with the USB 2.0 Specification and will attach to a USB host as a Full-Speed Hub or as a Full-/High-Speed Hub. The 4-Port Hub supports Low-Speed, Full-Speed, and High-Speed (if operating as a High-Speed Hub) downstream devices on all of the enabled downstream ports.

A dedicated Transaction Translator (TT) is available for each downstream facing port. This architecture ensures maximum USB throughput for each connected device when operating with mixed-speed peripherals.

The Hub works with an external USB power distribution switch device to control V_{BUS} switching to downstream ports, and to limit current and sense over-current conditions.

All required resistors on the USB ports are integrated into the Hub. This includes all series termination resistors on D+ and D- pins and all required pull-down and pull-up resistors on D+ and D- pins. The over-current sense inputs for the downstream facing ports have internal pull-up resistors.

Throughout this document the upstream facing port of the hub will be referred to as the upstream port, and the downstream facing ports will be called the downstream ports.

1.1 OEM Selectable Features

A default configuration is available in the USB2504/USB2504A following a reset. This configuration may be sufficient for some applications. Strapping option pins make it possible to modify a limited subset of the configuration options.

The USB2504/USB2504A may also be configured by an external EEPROM or a microcontroller. When using the microcontroller interface, the Hub appears as an SMBus slave device. If the Hub is pin-strapped for external EEPROM configuration but no external EEPROM is present, then a value of '0' will be written to all configuration data bit fields (the hub will attach to the host with all '0' values).

The 4-Port Hub supports several OEM selectable features:

- Operation as a Self-Powered USB Hub or as a Bus-Powered USB Hub.
- Operation as a Dynamic-Powered Hub (Hub operates as a Bus-Powered device if a local power source is not available and switches to Self-Powered operation when a local power source is available).
- Multiple Transaction Translator (Multi-TT) or Single-TT support.
- Optional OEM configuration via I2C EEPROM or via the industry standard SMBus interface from an external SMBus Host.
- Port power switching on an individual or ganged basis.
- Port over-current monitoring on an individual or ganged basis.
- LED indicator support.
- Compound device support (port is permanently hardwired to a downstream USB peripheral device).
- Hardware strapping options enable configuration of the following features.
 - Non-Removable Ports
 - Port Power Polarity (active high or active low logic)
 - Port Disable
 - LED support
 - MTT enable
 - Ganged Vs Port power switching and over-current sensing

Chapter 2 Pin Table 4-Port

Table 2.1 4-Port Pin Table for 64-TQFP

UPSTREAM USB 2.0 INTERFACE (3 PINS)			
USBDP0	USBDN0	VBUS_DET	
4-PORT USB 2.0 INTERFACE (26 PINS)			
USBDP1	USBDN1	USBDP2	USBDN2
USBDP3	USBDN3	USBDP4	USBDN4
GR1/ NON_REM0	GR2/ NON_REM1	GR3/ PRT_DIS0	GR4/ PRT_DIS1
AM1/ GANG_EN	AM2/ MTT_EN	AM3	AM4/ LED_EN
P RTPWR1	P RTPWR2	P RTPWR3	P RTPWR4
OCS1_N	OCS2_N	OCS3_N	OCS4_N
P RTPWR_POL	RBIAS		
SERIAL PORT INTERFACE (5 PINS)			
SDA/SMBDATA	SCL/SMBCLK/	CFG_SEL2	CFG_SEL1
CFG_SEL0			
MISC (8 PINS)			
XTAL1/CLKIN	XTAL2	RESET_N	SELF_PWR
ATEST/ REG_EN	CLKIN_EN	TEST1	TEST0
POWER, GROUND (17 PINS) AND (5) NO CONNECT			

Chapter 3 Pin Configuration 4-Port Hub

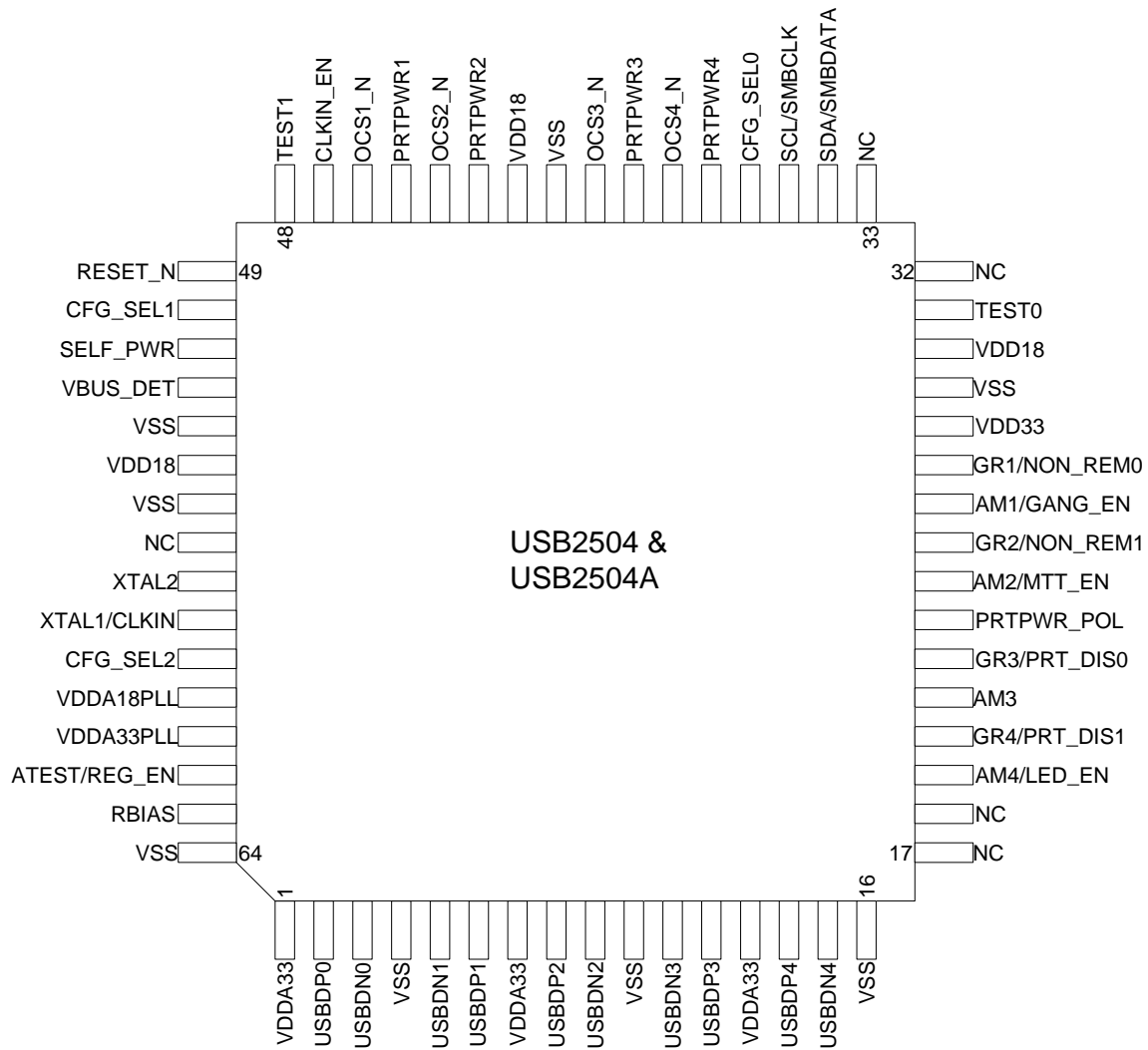

Figure 3.1 4-Port 64 Pin TQFP

Chapter 4 4-Port Hub Block Diagram

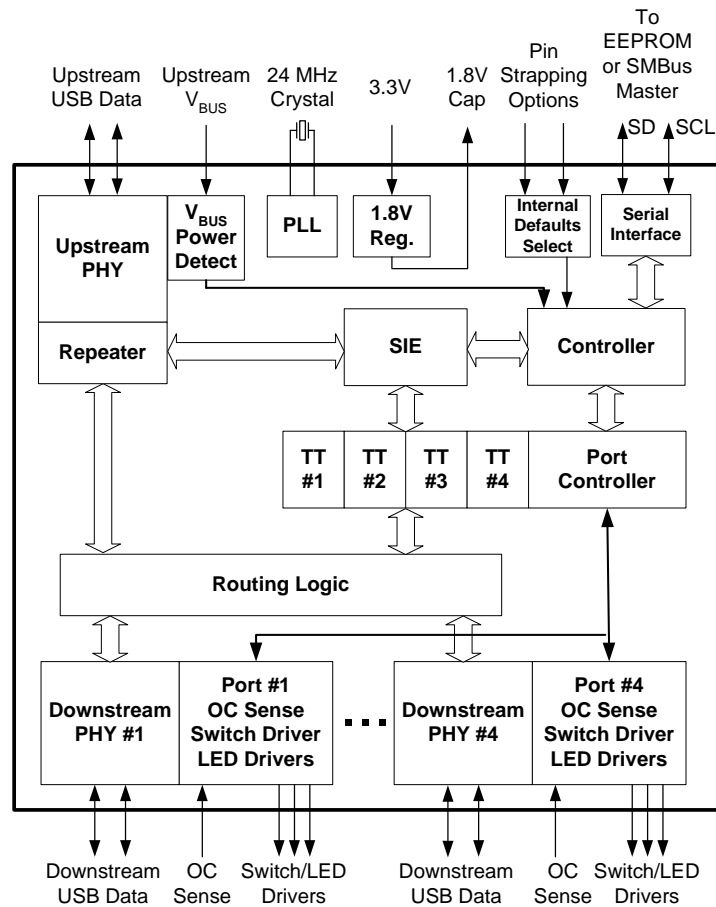

Figure 4.1 4-Port Block Diagram

Table 4.1 4-Port Hub Pin Descriptions

NAME	SYMBOL	TYPE	FUNCTION
UPSTREAM USB 2.0 INTERFACE			
USB Bus Data	USBDN0 USBDP0	IO-U	These pins connect to the upstream USB bus data signals.
Detect Upstream VBUS Power	VBUS_DET	I/O12	<p>Detects state of Upstream VBUS power. The SMSC Hub monitors VBUS_DET to determine when to assert the internal D+ pull-up resistor (signalling a connect event).</p> <p>When designing a detachable hub, this pin must be connected to the VBUS power pin of the USB port that is upstream of the hub. (Use of a weak pull-down resistor is recommended.)</p> <p>For self-powered applications with a permanently attached host, this pin must be pulled-up to either 3.3V or 5.0V (typically VDD33).</p>

Table 4.1 4-Port Hub Pin Descriptions (continued)

NAME	SYMBOL	TYPE	FUNCTION
4-PORT USB 2.0 HUB INTERFACE			
High-Speed USB Data	USBDN[4:1] USBDP[4:1]	IO-U	These pins connect to the downstream USB peripheral devices attached to the Hub's ports.
USB Power Enable	P RTPWR[4:1]	O12	Enables power to USB peripheral devices (downstream). The active signal level of the P RTPWR[4:1] pins is determined by the Power Polarity Strapping function of the P RTPWR_POL pin.
Port 4:3 Green LED & Port Disable strapping option.	GR[4:3]/ P RT_DIS[1:0]	I/O12	Green indicator LED for ports 4 and 3. Will be active low when LED support is enabled via EEPROM or SMBus. If the hub is configured by the internal default configuration, these pins will be sampled at RESET_N negation to determine if ports [4:2] will be permanently disabled. Also, the active state of the LED's will be determined as follows: P RT_DIS[1:0] = '00', All ports are enabled, GR4 is active high, GR3 is active high. P RT_DIS[1:0] = '01', Port 4 is disabled, GR4 is active high, GR3 is active low. P RT_DIS[1:0] = '10', Ports 4 & 3 are disabled, GR4 is active low, GR3 is active high. P RT_DIS[1:0] = '11', Ports 4, 3 & 2 are disabled, GR4 is active low, GR3 is active low.
Port [2:1] Green LED & Port Non-Removable strapping option.	GR[2:1]/ NON_REM[1:0]	I/O12	Green indicator LED for ports 2 and 1. Will be active low when LED support is enabled via EEPROM or SMBus. If the hub is configured by the internal default configuration, these pins will be sampled at RESET_N negation to determine if ports [3:1] contain permanently attached (non-removable) devices. Also, the active state of the LED's will be determined as follows: NON_REM[1:0] = '00', All ports are removable, GR2 is active high, GR1 is active high. NON_REM[1:0] = '01', Port 1 is non-removable, GR2 is active high, GR1 is active low. NON_REM[1:0] = '10', Ports 1 & 2 are non-removable, GR2 is active low, GR1 is active high. NON_REM[1:0] = '11', Ports 1, 2, & 3 are non-removable, GR2 is active low, GR1 is active low.

Table 4.1 4-Port Hub Pin Descriptions (continued)

NAME	SYMBOL	TYPE	FUNCTION
Port 4 Amber LED & LED Enable strapping option	AM4/ LED_EN	I/O12	<p>Amber indicator LED for port 4. Will be active low when LED support is enabled via EEPROM or SMBus.</p> <p>If the hub is configured by the internal default configuration, this pin will be sampled at RESET_N negation to determine if LED support is enabled or disabled. Also, the active state of the LED will be determined as follows:</p> <p>'0' = LED support is disabled, LED is inactive '1' = LED Support is enabled, LED is active low.</p>
Port 3 Amber LED	AM3	I/O12	Amber indicator LED for port 3. Signal will be active low.
Port 2 Amber LED & MTT Disable	AM2/ MTT_EN	I/O12	<p>Amber indicator LED for port 2. Will be active low when LED support is enabled via EEPROM or SMBus.</p> <p>If the hub is configured by the internal default configuration, this pin will be sampled at RESET_N negation to determine if MTT support is disabled (STT only). Also, the active state of the LED will be determined as follows:</p> <p>'0' = MTT support is disabled, LED is active high '1' = MTT support is enabled, LED is active low.</p>
Port 1 Amber LED & Gang Power Switching and Current Sensing strapping option.	AM1/ GANG_EN	I/O12	<p>Amber indicator LED for port 1, Will be active low when LED support is enabled via EEPROM or SMBus.</p> <p>If the hub is configured by the internal default configuration, this pin will be sampled at RESET_N negation to determine if downstream port power switching and current sensing are ganged, or individual port-by-port. Also, the active state of the LED will be determined as follows:</p> <p>'0' = Port-by-port sensing & switching, LED is active high '1' = Ganged sensing & switching, LED is active low.</p>
Port Power Polarity strapping.	P RTPWR_POL	I/O12	<p>Port Power Polarity strapping determination for the active signal polarity of the [4:1]P RTPWR pins.</p> <p>While RESET_N is asserted, the logic state of this pin will (though the use of internal combinatorial logic) determine the active state of the [4:1]P RTPWR pins in order to ensure that downstream port power is not inadvertently enabled to inactive ports during a hardware reset.</p> <p>On the rising edge of RESET_N (see the applicable RESET_N timing table in Section 5.6.1), the logic value will be latched internally, and will retain the active signal polarity for the P RTPWR[4:1] pins.</p> <p>'1' = P RTPWR[4:1]_P/N pins have an active 'high' polarity '0' = P RTPWR[4:1]_P/N pins have an active 'low' polarity</p>
Over Current Sense	OCS[4:1]_N	IPU	Input from external current monitor indicating an over-current condition. {Note: Contains internal pull-up to 3.3V supply}
USB Transceiver Bias	RBIAS	I-R	A 12.0kΩ (+/- 1%) resistor is attached from ground to this pin to set the transceiver's internal bias settings.

Table 4.1 4-Port Hub Pin Descriptions (continued)

NAME	SYMBOL	TYPE	FUNCTION
SERIAL PORT INTERFACE			
Serial Data/SMB Data	SDA/SMBDATA	IOSD12	(Serial Data)/(SMB Data) signal.
Serial Clock/SMB Clock	SCL/SMBCLK	IOSD12	(Serial Clock)/(SMB Clock) signal.
Configuration Programming Select	CFG_SEL0	IOSD12	This multifunction pin is read on the rising edge of RESET_N negation and will determine the hub configuration method as described in Table 4.2 .
Configuration Programming Select	CFG_SEL1	I	This pin is read on the rising edge of RESET_N (see the applicable RESET_N timing table in Section 5.6.1) and will determine the hub configuration method as described in Table 4.2 .
Configuration Programming Select	CFG_SEL2	I	This pin is read on the rising edge of RESET_N negation and will determine the hub configuration method as described in Table 4.2 .

Table 4.2 SMBus or EEPROM Interface Behavior

CFG_SEL2	CFG_SEL1	CFG_SEL0	SMBus or EEPROM interface behavior.
X	0	0	Configured as an SMBus slave for external download of user-defined descriptors. SMBus slave address is 0101100
X	0	1	Configured as an SMBus slave for external download of user-defined descriptors. SMBus slave address is 0101101
0	1	0	Internal Default Configuration
1	1	0	Internal Default Configuration via strapping options.
X	1	1	2-wire (I2C) EEPROMS are supported,

Table 4.3 Miscellaneous Pins

NAME	SYMBOL	TYPE	FUNCTION
Crystal Input/External Clock Input	XTAL1/CLKIN	ICLKx	24MHz crystal or external clock input. This pin connects to either one terminal of the crystal or to an external 24MHz clock when a crystal is not used.
Crystal Output	XTAL2	OCLKx	24MHz Crystal This is the other terminal of the crystal, or left unconnected when an external clock source is used to drive XTAL1/CLKIN. It must not be used to drive any external circuitry other than the crystal circuit.
Clock Input Enable	CLKIN_EN	I	Clock In Enable: Low = XTAL1 and XTAL2 pins configured for use with external crystal High = XTAL1 pin configured as CLKIN, and must be driven by an external CMOS clock.

Table 4.3 Miscellaneous Pins (continued)

NAME	SYMBOL	TYPE	FUNCTION
RESET Input	RESET_N	IS	This active low signal is used by the system to reset the chip. The minimum active low pulse is 1us.
Self-Power / Bus-Power Detect	SELF_PWR	I	Detects availability of local self-power source. Low = Self/local power source is NOT available (i.e., Hub gets all power from Upstream USB VBus). High = Self/local power source is available.
TEST Pins	TEST[1:0]	IPD	Used for testing the chip. User must treat as a no-connect or connect to ground.
Analog Test & Internal 1.8V voltage regulator enable	ATEST/ REG_EN	AIO	<p>This signal is used for testing the analog section of the chip, and to enable or disable the internal 1.8v regulator.</p> <p>This pin must be connected to VDDA33 to enable the internal 1.8V regulator, or to VSS to disable the internal regulator.</p> <p>When the internal regulator is enabled, the 1.8V power pins must be left unconnected, except for the required bypass capacitors. When the PHY is in test mode, the internal regulator is disabled and the ATEST pin functions as a test pin.</p>

Table 4.4 Power, Ground, and No Connect

NAME	SYMBOL	TYPE	FUNCTION
VDD1P8	VDD18		+1.8V core power. If the internal regulator is enabled, then VDD18 pin 54 must have a 4.7 μ F (or greater) \pm 20% (ESR <0.1 Ω) capacitor to VSS
VDDAPLL3P3	VDDA33PLL		+3.3V Filtered analog power for the internal PLL If the internal PLL 1.8V regulator is enabled, then this pin acts as the regulator input
VDDAPLL1P8	VDDA18PLL		+1.8V Filtered analog power for internal PLL. If the internal regulator is enabled, then this pin must have a 4.7 μ F (or greater) \pm 20% (ESR <0.1 Ω) capacitor to VSS
VDDIO3P3	VDD33		+3.3V I/O power.
VDDA3P3	VDDA33		+3.3V Filtered analog power.
VSS	VSS		Ground.

Table 4.5 Buffer Type Descriptions

BUFFER	DESCRIPTION
I	Input.
IPD	Input, with a weak Internal pull-down.
IPU	Input, with a weak Internal pull-up.
IS	Input with Schmitt trigger.
O12	Output 12mA.
I/O12	Input/Output, 12mA
IOSD12	Open drain....12mA sink with Schmitt trigger, and must meet I2C-Bus Specification Version 2.1 requirements.
ICLKx	XTAL Clock Input
OCLKx	XTAL Clock Output
I-R	RBIAS
IO-U	Defined in USB Specification. Note: Meets USB 1.1 requirements when operating as a 1.1-compliant device and meets USB 2.0 requirements when operating as a 2.0-compliant device.
AIO	Analog Input/output. Per PHY test requirements.

Chapter 5 Functional Block Description

5.1 4-Port Hub

SMSC's USB 2.0 4-Port Hub is fully specification compliant to the Universal Serial Bus Specification Revision 2.0 April 27,2000 (12/7/2000 and 5/28/2002 Errata). Please reference Chapter 11 (Hub Specification) for general details regarding Hub operation and functionality.

For performance reasons, the 4-Port Hub provides 1 Transaction Translator (TT) per port (defined as Multi-TT configuration), divided into 4 non-periodic buffers per TT.

5.1.1 Hub Configuration Options

The SMSC Hub supports a large number of features (some are mutually exclusive), and must be configured in order to correctly function when attached to a USB host controller. There are three principal ways to configure the hub: SMBus, EEPROM, or by internal default settings (with or without pin strapping option over-rides). In all cases, the configuration method will be determined by the CFG_SEL2, CFG_SEL1 and CFG_SEL0 pins immediately after RESET_N negation.

5.1.1.1 Vendor ID

Is a 16-bit value that uniquely identifies the Vendor of the user device (assigned by USB-Interface Forum). This field is set by the OEM using either the SMBus or EEPROM interface options. When using the internal default option, SMSC's VID (see [Table 5.1](#)) will be reported.

5.1.1.2 Product ID

Is a 16-bit value that the Vendor can assign that uniquely identifies this particular product (assigned by OEM). This field is set by the OEM using either the SMBus or EEPROM interface options. When using the internal default option, SMSC's PID designation of (see [Table 5.1](#)) will be reported.

5.1.1.3 Device ID

Is a 16-bit device release number in BCD format (assigned by OEM). This field is set by the OEM using either the SMBus or EEPROM interface options. When using the internal default option, SMSC's DID designation of (see [Table 5.1](#)) will be reported.

5.1.1.4 Self-Powered/Bus-Powered

The Hub is either Self-Powered (draws less than 2mA of upstream bus power) or Bus-Powered (limited to a 100mA maximum of upstream power prior to being configured by the host controller).

When configured as a Bus-Powered device, the SMSC Hub consumes less than 100mA of current prior to being configured. After configuration, the Bus-Powered SMSC Hub (along with all associated hub circuitry, any embedded devices if part of a compound device, and 100mA per externally available downstream port) must consume no more than 500mA of upstream VBUS current. The current consumption is system dependent, and the OEM must ensure that the USB 2.0 specifications are not violated.

When configured as a Self-Powered device, <1mA of upstream VBUS current is consumed and all 7 ports are available, with each port being capable of sourcing 500mA of current.

This field is set by the OEM using either the SMBus or EEPROM interface options. When using the internal default option, the SELF_PWR pin determines the Self-powered or Bus-powered status.

Please see the description under Dynamic Power for the self/bus power functionality when dynamic power switching is enabled.

Datasheet**5.1.1.5 Port Indicators**

Controls the use of LED indicator for Port status information. See Section 11.5.3 of the USB 2.0 Specification for additional details.

This field is set by the OEM using either the SMBus or EEPROM interface options. When using the internal default option, the LED_EN pin enables/disables LED Indicator support.

5.1.1.6 High-Speed Disable

Allows an OEM to force the Hub to configure as a Full-Speed device only (i.e. High-Speed not available).

This field is set by the OEM using either the SMBus or EEPROM interface options.

5.1.1.7 Multiple-TT Support

Selects between a mode where only one transaction translator is available for all ports (Single-TT), or each port gets a dedicated transaction translator (Multi-TT) {Note: The host may force Single-TT mode only}.

This field is set by the OEM using either the SMBus or EEPROM interface options. When using the internal default option, the MTT_EN pin enables/disables MTT support.

5.1.1.8 EOP Disable

During FS operation only, this permits the Hub to send EOP if no downstream traffic is detected at EOF1. See Section 11.3.1 of the USB 2.0 Specification for additional details.

This field is set by the OEM using either the SMBus or EEPROM interface options.

5.1.1.9 Current Sensing

Selects current sensing on a port-by-port basis, all ports ganged, or none(only for bus-powered hubs)The ability to support current sensing on a port or ganged basis is hardware implementation dependent.

This field can be set by the OEM using either the SMBus or EEPROM interface options. When using the internal default option, the SELF_PWR pin determines if current sensing will be ganged, or none (ganged if self-powered, none if bus-powered)

5.1.1.10 Downstream Port Power Enabling

Enables all ports simultaneously (ganged), or port power is individually switched on and off on a port-by-port basis. The ability to support power enabling on a port or ganged basis is hardware implementation dependent.

This field is set by the OEM using either the SMBus or EEPROM interface options. When using the internal default option, the GANG_EN pin will configure the hub for ganged or individual port-by-port power switching.

5.1.1.11 Compound Device

Allows the OEM to indicate that the Hub is part of a compound (see the USB Specification for definition) device. The applicable port(s) must also be defined as having a "Non-Removable Device".

This field is set by the OEM using either the SMBus or EEPROM interface options.

Note: When configured via strapping options, declaring a port as non-removable automatically causes the hub controller to report that it is part of a compound device.

5.1.1.12 Non-Removable Device

Informs the Host if one of the active ports has a permanent device that is undetachable from the Hub. (Note: The device must provide its own descriptor data.)

This field is set by the OEM using either the SMBus or EEPROM interface options. When using the internal default option, the NON_REM[1:0] pins will designate the appropriate ports as being non-removable.

5.1.1.13 Self-Powered Port DISABLE

During Self-Powered operation, this selects the ports which will be permanently disabled, and are not available to be enabled or enumerated by a Host Controller. The disabled ports must be contiguous, and must be in decreasing order starting with port 4.

This field is set by the OEM using either the SMBus or EEPROM interface options. When using the internal default option, the PRT_DIS[1:0] pins will disable the appropriate ports.

5.1.1.14 Bus-Powered Port DISABLE

During Bus-Powered operation, this selects the ports which will be permanently disabled, and are not available to be enabled or enumerated by a Host Controller. The disabled ports must be contiguous, and must be in decreasing order starting with port 4.

This field is set by the OEM using either the SMBus or EEPROM interface options. When using the internal default option, the PRT_DIS[1:0] pins will disable the appropriate ports.

5.1.1.15 Dynamic Power

Controls the ability of the 4-Port Hub to automatically change from Self-Powered operation to Bus-Powered operation if the local power source is removed or is unavailable (and from Bus-Powered to Self-Powered if the local power source is restored). {Note: If the local power source is available, the 4-port Hub will always switch to Self-Powered operation.}

When Dynamic Power switching is enabled, the Hub detects the availability of a local power source by monitoring the external SELF_PWR pin. If the Hub detects a change in power source availability, the Hub immediately disconnects and removes power from all downstream devices and disconnects the upstream port. The Hub will then re-attach to the upstream port as either a Bus-Powered Hub (if local-power is unavailable) or a Self-Powered Hub (if local power is available).

This field is set by the OEM using either the SMBus or EEPROM interface options.

5.1.1.16 Over-Current Timer

The time delay (in 2ms increments) for an over-current condition to persist before it is reported to the Host.

This field is set by the OEM using either the SMBus or EEPROM interface options.

5.1.1.17 Self-Powered Max Power

When in Self-Powered configuration, Sets value in 2mA increments.

This field is set by the OEM using either the SMBus or EEPROM interface options.

5.1.1.18 Bus-Powered Max Power

When in Bus-Powered configuration, Sets value in 2mA increments.

This field is set by the OEM using either the SMBus or EEPROM interface options.

Datasheet**5.1.1.19 Self-powered Hub Controller Current**

When in Self-Powered configuration, Maximum current requirements of the Hub Controller in 2mA increments.

This field is set by the OEM using either the SMBus or EEPROM interface options.

5.1.1.20 Bus-Powered Hub Controller Current

When in Bus-Powered configuration, Maximum current requirements of the Hub Controller in 2mA increments.

This field is set by the OEM using either the SMBus or EEPROM interface options.

5.1.1.21 Power-On Timer

Time (in 2ms intervals) from the time power-on sequence begins on a port until power is good on that port. System software uses this value to determine how long to wait before accessing a powered-on port.

This field is set by the OEM using either the SMBus or EEPROM interface options.

5.1.1.22 Power Switching Polarity

The selection of active state “polarity” for the PRTPWR[4:1] pins is made by a strapping option only.

5.1.2 VBus Detect

According to Section 7.2.1 of the USB 2.0 Specification, a downstream port can never provide power to its D+ or D- pull-up resistors unless the upstream port’s VBUS is in the asserted (powered) state. The VBUS_DET pin on the Hub monitors the state of the upstream VBUS signal and will not pull-up the D+ or D- resistor if VBUS is not active. If VBUS goes from an active to an inactive state (Not Powered), Hub will remove power from the D+ or D- pull-up resistor within 10 seconds.

5.2 EEPROM Interface

The SMSC Hub can be configured via a 2-wire (I2C) EEPROM. (Please see [Table 4.1, "7-Port Hub Pin Descriptions"](#) for specific details on how to enable the I2C EEPROM option).

The Internal state-machine will, (when configured for EEPROM support) read the external EEPROM for configuration data. The hub will then “attach” to the upstream USB host.

Please see [Table 5.1](#) User-Defined Descriptor Data for a list of data fields available.

5.2.1 I2C EEPROM

The I2C EEPROM interface implements a subset of the I2C Master Specification (Please refer to the Philips Semiconductor Standard I2C-Bus Specification for details on I2C bus protocols). The Hub’s I2C EEPROM interface is designed to attach to a single “dedicated” I2C EEPROM, and it conforms to the Standard-mode I2C Specification (100kbit/s transfer rate and 7-bit addressing) for protocol and electrical compatibility.

Note: Extensions to the I2C Specification are not supported.

The Hub acts as the master and generates the serial clock SCL, controls the bus access (determines which device acts as the transmitter and which device acts as the receiver), and generates the START and STOP conditions.

5.2.1.1 Implementation Characteristics

Please refer to the MicroChip 24AA00 DataSheet for Protocol and Programming specifics.

5.2.1.2 Pull-Up Resistor

The Circuit board designer is required to place external pull-up resistors (10KΩ recommended) on the SDA/SMBDATA & SCL/SMBCLK/CFG_SELO lines (per SMBus 1.0 Specification, and EEPROM manufacturer guidelines) to Vcc in order to assure proper operation.

5.2.1.3 I2C EEPROM Slave Address

Slave address is 1010000.

Note: 10-bit addressing is NOT supported.

5.2.2 In-Circuit EEPROM Programming

The EEPROM can be programmed via ATE by pulling RESET_N low (which tri-states the Hub's EEPROM interface and allows an external source to program the EEPROM).

5.2.3 EEPROM DATA

Table 5.1 User-Defined Descriptor Data

FIELD	BYTE MSB: LSB	SIZE (BYTES)	DEFAULT CFG SELF (HEX)	DEFAULT CFG BUS (HEX)	DESCRIPTION
VID	1:0	2	0424	0424	Vendor ID (assigned by USB-IF).
PID	3:2	2	4-port = 2504	4-Port = 2504	Product ID (assigned by Manufacturer).
DID	5:4	2	0000	0000	Device ID (assigned by Manufacturer).
Config Data Byte 1	6	1	98	1C	Configuration data byte #1 for Hub options.
Config Data Byte 2	7	1	90	90	Configuration data byte #2 for Hub options.
Non Removable Device	8	1	00	00	Defines the ports that contain attached devices (this is used only when Hub is part of a compound device).
Port Disable Self-Powered	9	1	00	00	Selects the ports that will be permanently disabled
Port Disable Bus-Powered	A	1	00	00	Selects the ports that will be permanently disabled
Max Power Self-Powered	B	1	01	01	Max Current for this configuration (expressed in 2mA units).
Max Power Bus-Powered	C	1	64	64	Max Current for this configuration (expressed in 2mA units).
Hub Controller Max Current Self-Powered	D	1	01	01	Max Current (expressed in 2mA units).
Hub Controller Max Current Bus-Powered	E	1	64	64	Max Current (expressed in 2mA units).
Power-On Time	F	1	32	32	Time until power is stable.

Datasheet

5.2.3.1 EEPROM Offset 1:0(h) - Vendor ID

BIT NUMBER	BIT NAME	DESCRIPTION
15:8	VID_MSB	Most Significant Byte of the Vendor ID.
7:0	VID_LSB	Least Significant Byte of the Vendor ID.

5.2.3.2 EEPROM Offset 3:2(h) - Product ID

BIT NUMBER	BIT NAME	DESCRIPTION
15:8	PID_MSB	Most Significant Byte of the Product ID.
7:0	PID_LSB	Least Significant Byte of the Product ID.

5.2.3.3 EEPROM Offset 5:4(h) - Device ID

BIT NUMBER	BIT NAME	DESCRIPTION
15:8	DID_MSB	Most Significant Byte of the Device ID.
7:0	DID_LSB	Least Significant Byte of the Device ID.

5.2.3.4 EEPROM Offset 6(h) - CONFIG_BYTE_1

BIT NUMBER	BIT NAME	DESCRIPTION
7	SELF_BUS_PWR	Self or Bus Power: Selects between Self- and Bus-Powered operation. 0 = Bus-Powered operation. (BUS Default) 1 = Self-Powered operation. (SELF Default) Note: If Dynamic Power Switching is enabled, this bit is ignored and the SELF_PWR pin is used to determine if the hub is operating from self or bus power.
6	PORT_IND	Port Indicator Support: Indicates implementation of LED indicators 0 = No LED indicators. 1 = LED indicators.
5	HS_DISABLE	High Speed Disable: Disables the capability to attach as either a High/Full-speed device, and forces attachment as Full-speed only i.e. (no High-Speed support). 0 = High-/Full-Speed. (Default) 1 = Full-Speed-Only (High-Speed disabled!)
4	MTT_ENABLE	Multi-TT enable: Enables one transaction translator per port operation. 0 = single TT for all ports. 1 = one TT per port (multiple TT's supported)

BIT NUMBER	BIT NAME	DESCRIPTION
3	EOP_DISABLE	EOP Disable: Disables EOP generation at EOF1 when no downstream directed traffic is in progress. 0 = EOP generation at EOF1 is enabled. 1 = EOP generation at EOF1 is disabled, (normal operation). (Default)
2:1	CURRENT_SNS	Over Current Sense: Indicates whether current sensing is on a port-by-port basis, or ganged, or no overcurrent sensing. 00 = Ganged sensing (all ports together). (Default for self-power) 01 = Individual port-by-port. 1x = Over current sensing not supported. (may be used with Bus-Powered configurations only!, and is the default for bus-power)
0	PORT_PWR	Port Power Switching: Indicates whether port power switching is on a port-by-port basis or ganged. 0 = Ganged switching (all ports together) 1 = Individual port-by-port switching.

5.2.3.5 EEPROM Offset 7(h) - CONFIG_BYTE_2

BIT NUMBER	BIT NAME	DESCRIPTION
7	DYNAMIC	Dynamic Power Enable: Controls the ability for the Hub to transition to Bus-Powered operation if the local power source is removed (can revert back to Self-Power if local power source is restored). 0 = No Dynamic auto-switching. 1 = Dynamic Auto-switching capable.(Default)
6	Reserved	Reserved
5:4	OC_TIMER	OverCurrent Timer: Over Current Timer delay. 00 = 0.1ms 01 = 2ms (Default) 10 = 4ms 11 = 6ms
3	COMPOUND	Compound Device: Designates if Hub is part of a compound device. 0 = No. (Default) 1 = Yes, Hub is part of a compound device.
2:0	Reserved	Reserved.

Datasheet

5.2.3.6 EEPROM Offset 8(h) - Non-Removable Device

BIT NUMBER	BIT NAME	DESCRIPTION
7:0	NR_DEVICE	<p>Non-Removable Device: Indicates which port(s) include non-removable devices. '0' = port is removable, '1' = port is non-removable.</p> <p>Bit 7= Reserved Bit 6= Reserved Bit 5= Reserved Bit 4= 1; Port 4 non-removable. Bit 3= 1; Port 3 non-removable. Bit 2= 1; Port 2 non-removable. Bit 1= 1; Port 1 non removable. Bit 0 is Reserved, always = '0'.</p>

5.2.3.7 EEPROM Offset 9(h) - Port Disable For Self Powered Operation

BIT NUMBER	BIT NAME	DESCRIPTION
7:0	PORT_DIS_SP	<p>Port Disable Self-Powered: Disables 1 or more contiguous ports. '0' = port is available, '1' = port is disabled.</p> <p>Bit 7= Reserved Bit 6= Reserved Bit 5= Reserved Bit 4= 1; Port 4 is disabled. Bit 3= 1; Port 3 is disabled. Bit 2= 1; Port 2 is disabled. Bit 1= 1; Port 1 is disabled. Bit 0 is Reserved, always = '0'</p>

5.2.3.8 EEPROM Offset A(h) - Port Disable For Bus Powered Operation

BIT NUMBER	BIT NAME	DESCRIPTION
7:0	PORT_DIS_BP	<p>Port Disable Bus-Powered: Disables 1 or more contiguous ports. '0' = port is available, '1' = port is disabled.</p> <p>Bit 7= Reserved Bit 6= Reserved Bit 5= Reserved Bit 4= 1; Port 4 is disabled. Bit 3= 1; Port 3 is disabled. Bit 2= 1; Port 2 is disabled. Bit 1= 1; Port 1 is disabled. Bit 0 is Reserved, always = '0'</p>

5.2.3.9 EEPROM Offset B(h) - Max Power For Self Powered Operation

BIT NUMBER	BIT NAME	DESCRIPTION
7:0	MAX_PWR_SP	<p>Max Power Self_Powered: Value in 2mA increments that the Hub consumes from an upstream port (VBUS) when operating as a self-powered hub. This value includes the hub silicon along with the combined power consumption (from VBUS) of all associated circuitry on the board. This value also includes the power consumption of a permanently attached peripheral if the hub is configured as a compound device, and the embedded peripheral reports 0mA in its descriptors.</p> <p>Note: The USB 2.0 Specification does not permit this value to exceed 100mA</p> <p>A value of 50 (decimal) indicates 100mA.</p>

5.2.3.10 EEPROM Offset C(h) - Max Power For Bus Powered Operation

BIT NUMBER	BIT NAME	DESCRIPTION
7:0	MAX_PWR_BP	<p>Max Power Bus_Powered: Value in 2mA increments that the Hub consumes from an upstream port (VBUS) when operating as a bus-powered hub. This value includes the hub silicon along with the combined power consumption (from VBUS) of all associated circuitry on the board. This value also includes the power consumption of a permanently attached peripheral if the hub is configured as a compound device, and the embedded peripheral reports 0mA in its descriptors.</p> <p>A value of 50 (decimal) indicates 100mA.</p>

5.2.3.11 EEPROM Offset D(h) - Hub Controller Max Current For Self Powered Operation

BIT NUMBER	BIT NAME	DESCRIPTION
7:0	HC_MAX_C_SP	<p>Hub Controller Max Current Self-Powered: Value in 2mA increments that the Hub consumes from an upstream port (VBUS) when operating as a self-powered hub. This value includes the hub silicon along with the combined power consumption (from VBUS) of all associated circuitry on the board. This value does NOT include the power consumption of a permanently attached peripheral if the hub is configured as a compound device.</p> <p>Note: The USB 2.0 Specification does not permit this value to exceed 100mA</p> <p>A value of 50 (decimal) indicates 100mA, which is the default value.</p>

5.2.3.12 EEPROM Offset E(h) - Hub Controller Max Current For Bus Powered Operation

BIT NUMBER	BIT NAME	DESCRIPTION
7:0	HC_MAX_C_BP	Hub Controller Max Current Bus-Powered: Value in 2mA increments that the Hub consumes from an upstream port (VBUS) when operating as a self-powered hub. This value includes the hub silicon along with the combined power consumption (from VBUS) of all associated circuitry on the board. This value does NOT include the power consumption of a permanently attached peripheral if the hub is configured as a compound device. A value of 50 (decimal) indicates 100mA, which is the default value.

5.2.3.13 EEPROM Offset F(h) - Power-On Time

BIT NUMBER	BIT NAME	DESCRIPTION
7:0	POWER_ON_TIME	Power On Time: The length of time that it takes (in 2 ms intervals) from the time the host initiated power-on sequence begins on a port until power is good on that port.

5.3 SMBus Slave Interface

Instead of loading User-Defined Descriptor data from an external EEPROM, the SMSC Hub can be configured to receive a code load from an external processor via an SMBus interface. The SMBus interface shares the same pins as the EEPROM interface, if CFG_SEL1 & CFG_SEL0 activates the SMBus interface, external EEPROM support is no longer available (and the user-defined descriptor data must be downloaded via the SMBus). Due to system issues, the SMSC Hub waits indefinitely for the SMBus code load to complete and only “appears” as a newly connected device on USB after the code load is complete.

The Hub’s SMBus implementation is a subset of the SMBus interface to the host. The device is a *slave-only* SMBus device. The implementation in the device is a subset of SMBus since it only supports two protocols.

The Write Byte and Read Byte protocols are the only valid SMBus protocols for the Hub. The Hub responds to other protocols as described in [Section 5.3.2, "Invalid Protocol Response Behavior," on page 26](#). Reference the System Management Bus Specification, Rev 1.0.

The SMBus interface is used to read and write the registers in the device. The register set is shown in [Section 5.3.9, "Internal SMBus Memory Register Set," on page 27](#).

5.3.1 Bus Protocols

Typical Write Byte and Read Byte protocols are shown below. Register accesses are performed using 7-bit slave addressing, an 8-bit register address field, and an 8-bit data field. The shading indicates the Hub driving data on the SMBDATA line; otherwise, host data is on the SDA/SMBDATA line.

The slave address is the unique SMBus Interface Address for the Hub that identifies it on SMBus. The register address field is the internal address of the register to be accessed. The register data field is the data that the host is attempting to write to the register or the contents of the register that the host is attempting to read.

Note: Data bytes are transferred MSB first (msb first).

5.3.1.1 Byte Protocols

When using the Hub SMBus Interface for byte transfers, a write will always consist of the SMBus Interface Slave Address byte, followed by the Internal Address Register byte, then the data byte.

The normal read protocol consists of a write to the HUB with the SMBus Interface Address byte, followed by the Internal Address Register byte. Then restart the Serial Communication with a Read consisting of the SMBus Interface Address byte, followed by the data byte read from the Hub. This can be accomplished by using the Read Byte protocol.

Note: For the following SMBus tables:

Denotes Master-to-Slave Denotes Slave-to-Master

Write Byte

The Write Byte protocol is used to write data to the registers. The data will only be written if the protocol shown in [Table 5.2](#) is performed correctly. Only one byte is transferred at a time for a Write Byte protocol.

Table 5.2 SMBus Write Byte Protocol

Field:	Start	Slave Addr	Wr	Ack	Reg. Addr	Ack	Reg. Data	Ack	Stop
Bits:	1	7	1	1	8	1	8	1	1

Read Byte

The Read Byte protocol is used to read data from the registers. The data will only be read if the protocol shown in [Table 5.3](#) is performed correctly. Only one byte is transferred at a time for a Read Byte protocol.

Table 5.3 SMBus Read Byte Protocol

Field:	Start	Slave Addr	Wr	Ack	Reg. Addr	Ack	Start	Slave Addr	Rd	Ack	Reg. Data	Nack	Stop
Bits:	1	7	1	1	8	1	1	7	1	1	8	1	1

5.3.2 Invalid Protocol Response Behavior

Registers that are accessed with an invalid protocol are not updated. A register is only updated following a valid protocol. The only valid protocols are Write Byte and Read Byte, which are described above.

The Hub only responds to the hardware selected Slave Address.

Attempting to communicate with the Hub over SMBus with an invalid slave address or invalid protocol results in no response, and the SMBus Slave Interface returns to the idle state.

The only valid registers that are accessible by the SMBus slave address are the registers defined in the Registers Section. See [Section 5.3.3](#) for the response to undefined registers.

5.3.3 General Call Address Response

The Hub does not respond to a general call address of 0000_000b.

Datasheet

5.3.4 Slave Device Time-Out

According to the SMBus Specification, V1.0 devices in a transfer can abort the transfer in progress and release the bus when any single clock low interval exceeds 25ms ($T_{\text{TIMEOUT, MIN}}$). Devices that have detected this condition must reset their communication and be able to receive a new START condition no later than 35ms ($T_{\text{TIMEOUT, MAX}}$).

Note: Some simple devices do not contain a clock low drive circuit; this simple kind of device typically resets its communications port after a start or stop condition.

5.3.5 Stretching the SCLK Signal

The Hub supports stretching of the SCLK by other devices on the SMBus. The Hub does not stretch the SCLK.

5.3.6 SMBus Timing

The SMBus Slave Interface complies with the SMBus AC Timing Specification. See the SMBus timing in the “Timing Diagram” section.

5.3.7 Bus Reset Sequence

The SMBus Slave Interface resets and returns to the idle state upon a START field followed immediately by a STOP field.

5.3.8 SMBus Alert Response Address

The SMBALERT# signal is not supported by the Hub.

5.3.9 Internal SMBus Memory Register Set

The following table provides the SMBus slave interface register map values.

Table 5.4 SMBus Slave Interface Register Map

REG ADDR	R/W	REGISTER NAME	ABBR	BIT 7 (MSB)	BIT 6	BIT 5	BIT 4	BIT 3	BIT 2	BIT 1	BIT 0 (LSB)
00h	R/W	Status/Command	STCD	7	6	5	4	3	2	1	0
01h	R/W	VID LSB	VIDL	7	6	5	4	3	2	1	0
02h	R/W	VID MSB	VIDM	7	6	5	4	3	2	1	0
03h	R/W	PID LSB	PIDL	7	6	5	4	3	2	1	0
04h	R/W	PID MSB	PIDM	7	6	5	4	3	2	1	0
05h	R/W	DID LSB	DIDL	7	6	5	4	3	2	1	0
06h	R/W	DID MSB	DIDM	7	6	5	4	3	2	1	0
07h	R/W	Config Data Byte 1	CFG1	7	6	5	4	3	2	1	0
08h	R/W	Config Data Byte 2	CFG2	7	6	5	4	3	2	1	0
09h	R/W	Non-Removable Devices	NRD	7	6	5	4	3	2	1	0
0Ah	R/W	Port Disable (Self)	PDS	7	6	5	4	3	2	1	0
0Bh	R/W	Port Disable (Bus)	PDB	7	6	5	4	3	2	1	0

Table 5.4 SMBus Slave Interface Register Map (continued)

REG ADDR	R/W	REGISTER NAME	ABBR	BIT 7 (MSB)	BIT 6	BIT 5	BIT 4	BIT 3	BIT 2	BIT 1	BIT 0 (LSB)
0Ch	R/W	Max Power (Self)	MAXPS	7	6	5	4	3	2	1	0
0Dh	R/W	Max Power (Bus)	MAXPB	7	6	5	4	3	2	1	0
0Eh	R/W	Hub Controller Max Current (Self)	HCMCS	7	6	5	4	3	2	1	0
0Fh	R/W	Hub Controller Max Current (bus)	HCMCB	7	6	5	4	3	2	1	0
10h	R/W	Power-on Time	PWRT	7	6	5	4	3	2	1	0

5.3.9.1 Register 00h: Status/Command (Reset = 0x00)

BIT NUMBER	BIT NAME	DESCRIPTION
7:3	Reserved	Reserved. {Note: Software must never write a '1' to these bits}
2	RESET	Reset the SMBus Interface and internal memory back to RESET_N assertion default settings. {Note: During this reset, this bit is automatically cleared to its default value of 0.} 0 = Normal Run/Idle State. 1 = Force a reset.
1	WRITE_PROT	Write Protect: The external SMBus host sets this bit after the Hub's internal memory is loaded with configuration data. {Note: The External SMBus Host is responsible for verification of downloaded data.} 0 = The internal memory (address range 01-10h) is not write protected. 1 = The internal memory (address range 01-10h) is "write-protected" to prevent unintentional data corruption. {Note: This bit is write once and is only cleared by assertion of the external RESET_N pin.}
0	USB_ATTACH	USB Attach & power-down the SMBus Interface. 0 = Default; SMBus slave interface is active. 1 = Hub will signal a USB attach event to an upstream device, Note: SMBus Slave interface will completely power down after the ACK has completed. {Note: This bit is write once and is only cleared by assertion of the external RESET_N pin.}

5.3.9.2 Register 01h: Vendor ID (LSB) (Reset = 0x00)

BIT NUMBER	BIT NAME	DESCRIPTION
7:0	VID_LSB	Least Significant Byte of the Vendor ID.

Datasheet

5.3.9.3 Register 02h: Vendor ID (MSB) (Reset = 0x00)

BIT NUMBER	BIT NAME	DESCRIPTION
7:0	VID_MSB	Most Significant Byte of the Vendor ID.

5.3.9.4 Register 03h: Product ID (LSB) (Reset = 0x00)

BIT NUMBER	BIT NAME	DESCRIPTION
7:0	PID_LSB	Least Significant Byte of the Product ID.

5.3.9.5 Register 04h: Product ID (MSB) (Reset = 0x00)

BIT NUMBER	BIT NAME	DESCRIPTION
7:0	PID_MSB	Most Significant Byte of the Product ID.

5.3.9.6 Register 05h: Device ID (LSB) (Reset = 0x00)

BIT NUMBER	BIT NAME	DESCRIPTION
7:0	DID_LSB	Least Significant Byte of the Device ID.

5.3.9.7 Register 06h: Device ID (MSB) (Reset = 0x00)

BIT NUMBER	BIT NAME	DESCRIPTION
7:0	DID_MSB	Most Significant Byte of the Device ID.

5.3.9.8 Register 07h: CONFIG_BYTE_1 (Reset = 0x00)

BIT NUMBER	BIT NAME	DESCRIPTION
7	SELF_BUS_PWR	Self or Bus Power: Selects between Self- and Bus-Powered operation. 0 = Bus-Powered operation. 1 = Self-Powered operation. Note: If Dynamic Power Switching is enabled, this bit is ignored and the SELF_PWR pin is used to determine if the hub is operating from self or bus power.
6	PORT_IND	Port Indicator Support: Indicates implementation of LED indicators 0 = No LED indicators. 1 = LED indicators.

BIT NUMBER	BIT NAME	DESCRIPTION
5	HS_DISABLE	High Speed Disable: Disables the capability to attach as either a High/Full-speed device, and forces attachment as Full-speed only i.e. (no High-Speed support). 0 = High-/Full-Speed. 1 = Full-Speed-Only (High-Speed disabled!)
4	MTT_ENABLE	Multi-TT enable: Enables one transaction translator per port operation. 0 = single TT for all ports. 1 = one TT per port (multiple TT's supported)
3	EOP_DISABLE	EOP Disable: Disables EOP generation of EOF1 when in Full-Speed mode. 0 = EOP generation is normal. 1 = EOP generation is disabled.
2:1	CURRENT_SNS	Over Current Sense: Indicates whether current sensing is on a port-by-port basis, or ganged, or no overcurrent sensing. 00 = Ganged sensing (all ports together). 01 = Individual port-by-port. 1x = Over current sensing not supported. (must only be used with Bus-Powered configurations!)
0	PORT_PWR	Port Power Switching: Indicates whether port power switching is on a port-by-port basis or ganged. 0 = Ganged switching (all ports together) 1 = Individual port-by-port switching.

5.3.9.9 Register 08h: Configuration Data Byte 2 (Reset = 0x00)

BIT NUMBER	BIT NAME	DESCRIPTION
7	DYNAMIC	Dynamic Power Enable: Controls the ability for the Hub to transition to Bus-Powered operation if the local power source is removed (can revert back to Self-Power if local power source is restored). 0 = No Dynamic auto-switching. 1 = Dynamic Auto-switching capable.
6	Reserved	Reserved
5:4	OC_TIMER	OverCurrent Timer: Over Current Timer delay. 00 = 0.1ms 01 = 2ms 10 = 4ms 11 = 6ms
3	COMPOUND	Compound Device: Designates if Hub is part of a compound device. 0 = No. 1 = Yes, Hub is part of a compound device.
2:0	Reserved	Reserved

Datasheet

5.3.9.10 Register 09h: Non-Removable Device (Reset = 0x00)

BIT NUMBER	BIT NAME	DESCRIPTION
7:0	NR_DEVICE	<p>Non-Removable Device: Indicates which port(s) include non-removable devices. '0' = port is removable, '1' = port is non-removable.</p> <p>Bit 7= Reserved Bit 6= Reserved Bit 5= Reserved Bit 4= 1; Port 4 non-removable. Bit 3= 1; Port 3 non-removable. Bit 2= 1; Port 2 non-removable. Bit 1= 1; Port 1 non removable. Bit 0 is Reserved, always = '0'.</p>

5.3.9.11 Register 0Ah: Port Disable For Self Powered Operation (Reset = 0x00)

BIT NUMBER	BIT NAME	DESCRIPTION
7:0	PORT_DIS_SP	<p>Port Disable Self-Powered: Disables 1 or more contiguous ports. '0' = port is available, '1' = port is disabled.</p> <p>Bit 7= Reserved Bit 6= Reserved Bit 5= Reserved Bit 4= 1; Port 4 is disabled. Bit 3= 1; Port 3 is disabled. Bit 2= 1; Port 2 is disabled. Bit 1= 1; Port 1 is disabled. Bit 0 is Reserved, always = '0'</p>

5.3.9.12 Register 0Bh: Port Disable For Bus Powered Operation (Reset = 0x00)

BIT NUMBER	BIT NAME	DESCRIPTION
7:0	PORT_DIS_BP	<p>Port Disable Bus-Powered: Disables 1 or more contiguous ports. '0' = port is available, '1' = port is disabled.</p> <p>Bit 7= Reserved Bit 6= Reserved Bit 5= Reserved Bit 4= 1; Port 4 is disabled. Bit 3= 1; Port 3 is disabled. Bit 2= 1; Port 2 is disabled. Bit 1= 1; Port 1 is disabled. Bit 0 is Reserved, always = '0'</p>

5.3.9.13 Register 0Ch: Max Power For Self Powered Operation (Reset = 0x00)

BIT NUMBER	BIT NAME	DESCRIPTION

7:0	MAX_PWR_SP	<p>Max Power Self_Powered: Value in 2mA increments that the Hub consumes from an upstream port (VBUS) when operating as a self-powered hub. This value includes the hub silicon along with the combined power consumption (from VBUS) of all associated circuitry on the board. This value also includes the power consumption of a permanently attached peripheral if the hub is configured as a compound device, and the embedded peripheral reports 0mA in its descriptors.</p> <p>Note: The USB 2.0 Specification does not permit this value to exceed 100mA</p> <p>A value of 50 (decimal) indicates 100mA.</p>
-----	------------	--

5.3.9.14 Register 0Dh: Max Power For Bus Powered Operation (Reset = 0x00)

BIT NUMBER	BIT NAME	DESCRIPTION
7:0	MAX_PWR_BP	<p>Max Power Bus_Powered: Value in 2mA increments that the Hub consumes from an upstream port (VBUS) when operating as a bus-powered hub. This value includes the hub silicon along with the combined power consumption (from VBUS) of all associated circuitry on the board. This value also includes the power consumption of a permanently attached peripheral if the hub is configured as a compound device, and the embedded peripheral reports 0mA in its descriptors.</p> <p>A value of 50 (decimal) indicates 100mA.</p>

5.3.9.15 Register 0Eh: Hub Controller Max Current For Self Powered Operation (Reset = 0x00)

BIT NUMBER	BIT NAME	DESCRIPTION
7:0	HC_MAX_C_SP	<p>Hub Controller Max Current Self-Powered: Value in 2mA increments that the Hub consumes from an upstream port (VBUS) when operating as a self-powered hub. This value includes the hub silicon along with the combined power consumption (from VBUS) of all associated circuitry on the board. This value does NOT include the power consumption of a permanently attached peripheral if the hub is configured as a compound device.</p> <p>Note: The USB 2.0 Specification does not permit this value to exceed 100mA</p> <p>A value of 50 (decimal) indicates 100mA, which is the default value.</p>

5.3.9.16 Register 0Fh: Hub Controller Max Current For Bus Powered Operation (Reset = 0x00)

BIT NUMBER	BIT NAME	DESCRIPTION
7:0	HC_MAX_C_BP	<p>Hub Controller Max Current Bus-Powered: Value in 2mA increments that the Hub consumes from an upstream port (VBUS) when operating as a bus-powered hub. This value will include the hub silicon along with the combined power consumption (from VBUS) of all associated circuitry on the board. This value will NOT include the power consumption of a permanently attached peripheral if the hub is configured as a compound device.</p> <p>A value of 50 (decimal) would indicate 100mA, which is the default value.</p>

Datasheet

5.3.9.17 Register 10h: Power-On Time (Reset = 0x00)

BIT NUMBER	BIT NAME	DESCRIPTION
7:0	POWER_ON_TIME	Power On Time: The length of time that it takes (in 2 ms intervals) from the time the host initiated power-on sequence begins on a port until power is good on that port.

5.3.9.18 Undefined Registers

The registers shown in [Table 5.4](#) are the defined registers in the Hub. Reads to undefined registers return 00h. Writes to undefined registers have no effect and do not return an error.

5.3.9.19 Reserved Registers

Unless otherwise instructed, only a '0' may be written to all reserved registers or bits.

5.4 Default Configuration Option:

The SMSC Hub can be configured via its internal default configuration. (please see [for specific details on how to enable default configuration.](#)

Please refer to [Table 5.1 on page 20](#) for the internal default values that are loaded when this option is selected.

5.5 Default Strapping Options:

The SMSC Hub can be configured via a combination of internal default values and pin strap options. Please see [Table 4.1, "7-Port Hub Pin Descriptions"](#) for specific details on how to enable the default/pin-strap configuration option.

The strapping option pins only cover a limited sub-set of the configuration options. The internal default values will be used for the bits & registers that are not controlled by a strapping option pin. Please refer to [Table 5.1 on page 20](#) for the internal default values that are loaded when this option is selected.

The Amber and Green LED pins are sampled after RESET_N negation, and the logic values are used to configure the hub if the internal default configuration mode is selected. The implementation shown below (see [Figure 5.1](#)) shows a recommended passive scheme. When a pin is configured with a "Strap High" configuration, the LED functions with active low signalling, and the PAD will "sink" the current from the external supply. When a pin is configured with a "Strap Low" configuration, the LED functions with active high signalling, and the PAD will "source" the current to the external LED.

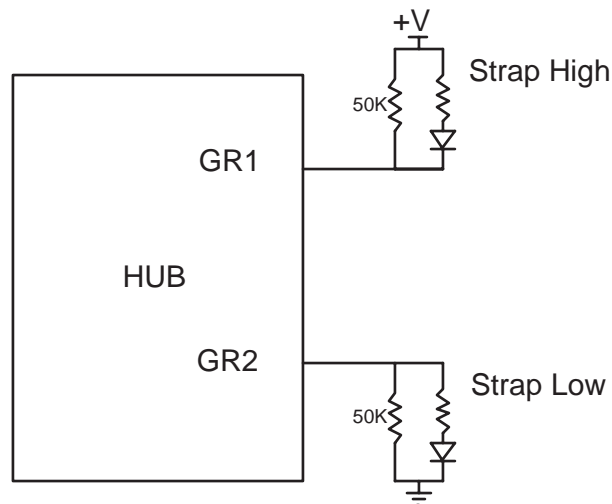
Figure 5.1 LED Strapping Option

5.6 Reset

There are two different resets that the Hub experiences. One is a hardware reset (via the RESET_N pin) and the second is a USB Bus Reset.

5.6.1 External Hardware RESET_N

A valid hardware reset is defined as, assertion of RESET_N for a minimum of 1us after all power supplies are within operating range. While reset is asserted, the Hub (and its associated external circuitry) consumes less than 500 μ A of current from the upstream USB power source (300 μ A for the Hub and 200 μ A for the external circuitry).

Assertion of RESET_N (external pin) causes the following:

1. All downstream ports are disabled, and PRTPWR power to downstream devices is removed.
2. The PHYs are disabled, and the differential pairs will be in a high-impedance state.
3. All transactions immediately terminate; no states are saved.
4. All internal registers return to the default state (in most cases, 00(h)).
5. The external crystal oscillator is halted.
6. The PLL is halted.
7. LED indicators are disabled.

The Hub is "operational" 500 μ s after RESET_N is negated.

Once operational, the Hub immediately reads OEM-specific data from the external EEPROM (if the SMBus option is not disabled).

Datasheet

5.6.1.1 RESET_N for Strapping Option Configuration

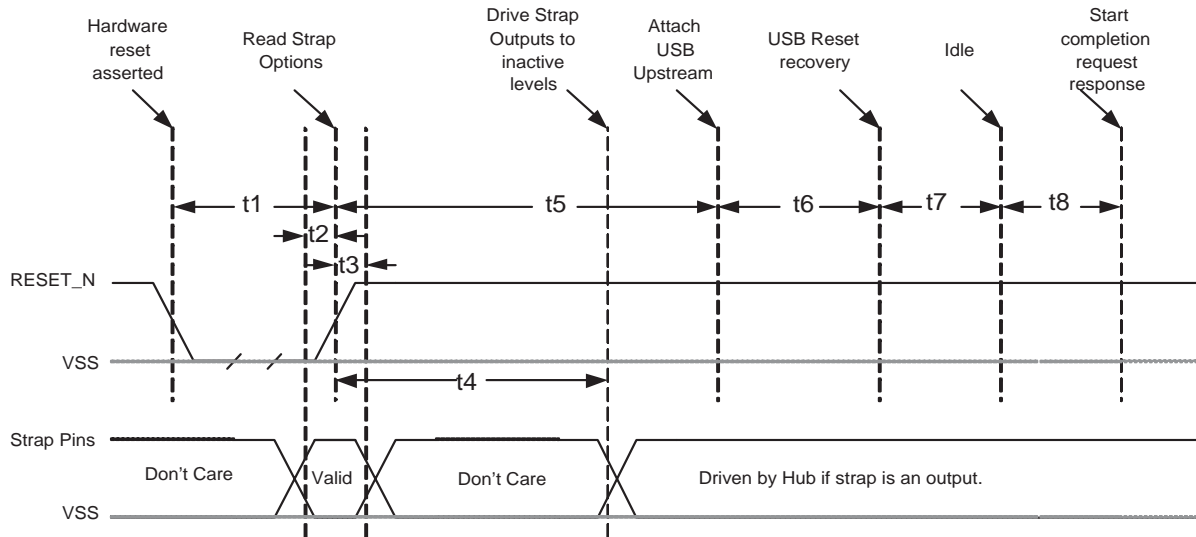

Figure 5.2 Reset_N Timing for Default/Strap Option Mode

Table 5.5 Reset_N Timing for Default/Strap Option Mode

NAME	DESCRIPTION	MIN	TYP	MAX	UNITS
t1	RESET_N Asserted.	1			μsec
t2	Strap Setup Time	16.7			nsec
t3	Strap Hold Time.	16.7		1400	nsec
t4	hub outputs driven to inactive logic states		2.0	1.5	μsec
t5	USB Attach (See Note).			100	msec
t6	Host acknowledges attach and signals USB Reset.	100			msec
t7	USB Idle.		undefined		msec
t8	Completion time for requests (with or without data stage).			5	msec

Notes:

- When in Bus-Powered mode, the Hub and its associated circuitry must not consume more than 100mA from the upstream USB power source during t1+t5.
- All Power Supplies must have reached the operating levels mandated in [Section Chapter 8, "DC Parameters"](#), prior to (or coincident with) the assertion of RESET_N.

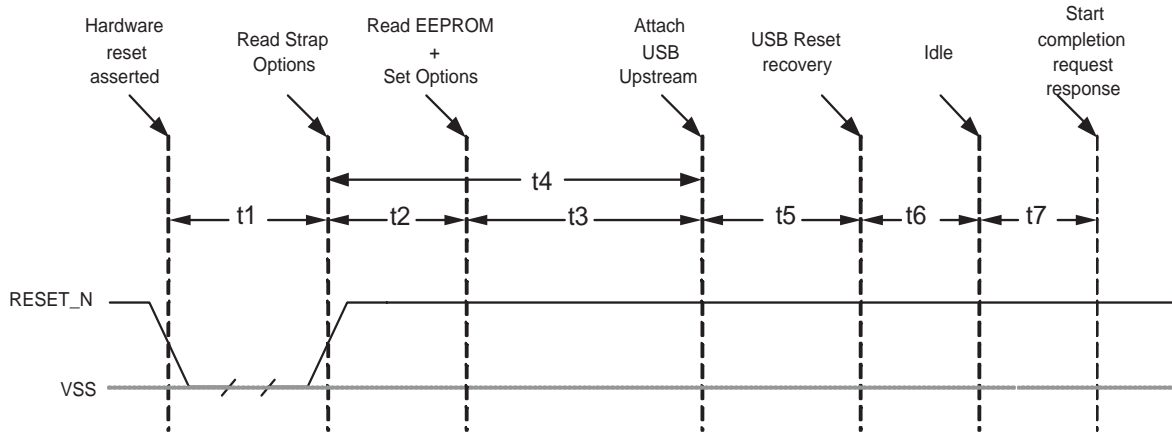
5.6.1.2 RESET_N for EEPROM Configuration

Figure 5.3 Reset_N Timing for EEPROM Mode
Table 5.6 Reset_N Timing for EEPROM Mode

NAME	DESCRIPTION	MIN	TYP	MAX	UNITS
t1	RESET_N Asserted.	1			μsec
t2	Hub Recovery/Stabilization.			500	μsec
t3	EEPROM Read / Hub Config.		2.0	99.5	msec
t4	USB Attach (See Note).			100	msec
t5	Host acknowledges attach and signals USB Reset.	100			msec
t6	USB Idle.		undefined		msec
t7	Completion time for requests (with or without data stage).			5	msec

Notes:

- When in Bus-Powered mode, the Hub and its associated circuitry must not consume more than 100mA from the upstream USB power source during t4+t5+t6+t7.
- All Power Supplies must have reached the operating levels mandated in [Section Chapter 8, "DC Parameters"](#), prior to (or coincident with) the assertion of RESET_N.

5.6.1.3 RESET_N for SMBus Slave Configuration

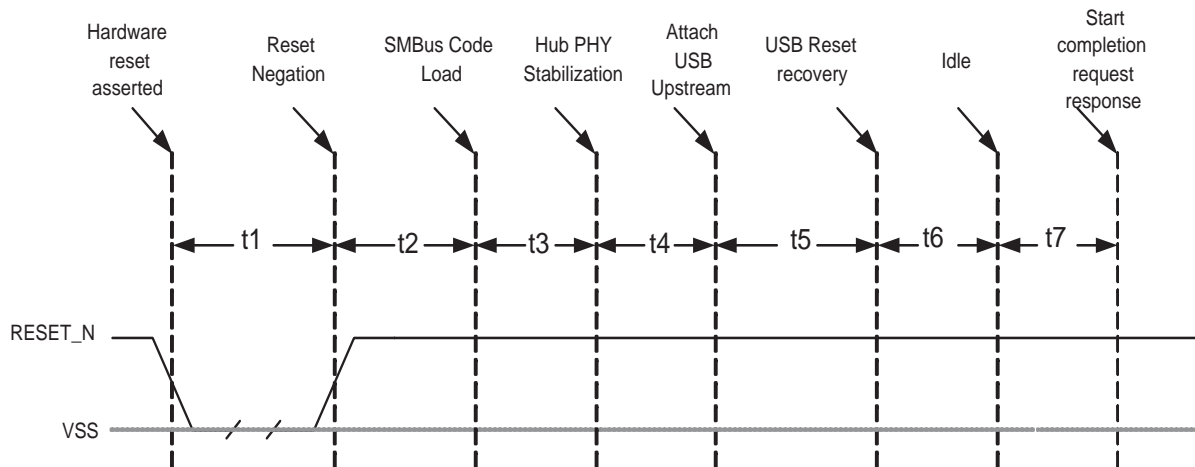

Figure 5.4 Reset_N Timing for SMBus Mode

Table 5.7 Reset_N Timing for SMBus Mode

NAME	DESCRIPTION	MIN	TYP	MAX	UNITS
t1	RESET_N Asserted.	1			μsec
t2	Hub Recovery/Stabilization.			500	μsec
t3	SMBus Code Load (See Note).		10	99.5	msec
t4	Hub Configuration and USB Attach.			100	msec
t5	Host acknowledges attach and signals USB Reset.	100			msec
t6	USB Idle.		Undefined		msec
t7	Completion time for requests (with or without data stage).			5	msec

Notes:

- For Bus-Powered configurations, the 99.5ms (MAX) is required, and the Hub and its associated circuitry must not consume more than 100mA from the upstream USB power source during t2+t3+t4+t5+t6+t7. For Self-Powered configurations, t3 MAX is not applicable and the time to load the configuration is determined by the external SMBus host.
- All Power Supplies must have reached the operating levels mandated in [Section Chapter 8, "DC Parameters"](#), prior to (or coincident with) the assertion of RESET_N.

5.6.2 USB Bus Reset

In response to the upstream port signaling a reset to the Hub, the Hub does the following:

Note: The Hub does not propagate the upstream USB reset to downstream devices.

- Sets default address to 0.
- Sets configuration to: Unconfigured.
- Negates PRTPWR[4:1] to all downstream ports.
- Clears all TT buffers.

5. Moves device from suspended to active (if suspended).
6. Complies with Section 11.10 of the USB 2.0 Specification for behavior after completion of the reset sequence.

The Host then configures the Hub and the Hub's downstream port devices in accordance with the USB Specification.

Chapter 6 Backward Compatibility to the USB20H04

The USB2504/USB2504A is pin compatible to the USB20H04, but is not designed to be a direct drop-in replacement. Many existing USB20H04 designs may accommodate a USB2504/USB2504A in place of the USB20H04, as long as specific Bill-Of-Material (BOM) modifications and population option changes are implemented. Since each design is unique, every customer considering a change from a USB20H04 to a USB2504/USB2504A should contact SMSC Applications Engineering for assistance.

6.1 Internal 1.8V regulator

The USB2504/USB2504A has two internal 1.8V regulators that are enabled by default (ATEST pin contains an internal pull-up, and was specified as a No-Connect in the USB20H04 datasheet). Each regulator requires a separate 4.7uF Low ESR capacitor to ground. The USB20H04 designs that directly connect the Digital and Analog 1.8V pins together will not support a USB2504/USB2504A (unless the internal regulators are disabled).

6.2 Configuration by Internal Defaults

The internal default settings that are loaded when this option is selected are very similar (but not identical) to those that were loaded in the USB20H04. The CFG_SEL[2:0] pins will properly select this method if the existing USB20H04 design was set-up to load the configuration via internal defaults.

The USB2504/USB2504A has pin strapping options that enable modification of the internal default load without requiring an EEPROM. The CFG_SEL2 pin (pin 59) on the USB2504/USB2504A was a VSS pin on the USB20H04 so this functionality will be disabled when a USB2504/USB2504A is placed into a USB20H04 design.

6.3 Configuration by SMBus

The CFG_SEL[2:0] pins will properly select this method if the existing USB20H04 design was set-up to load the configuration via SMBus. The USB2504/USB2504A has a few additional registers, and has also moved some of the configuration bits so the actual SMBus code load itself will need to be modified. If a USB20H04 SMBus load is programmed into a USB2504/USB2504A, the results are unpredictable.

6.4 PRTPWR_POL

The USB2504/USB2504A has a new strapping option that enables the port power control active state to be either active-high or active-low. The USB20H04 only provided active-low port power control. The PRTPWR_POL pin on the USB2504/USB2504A is pin 23, which was a VSS pin on the USB20H04, so by default, a USB20H04 design will select active-low port power control.

Chapter 7 XNOR Test

XNOR continuity tests all signal pins on the Hub (every pin except for NC, XTAL1/CLKIN, XTAL2, ATEST/REG_EN, RBIAS, TEST1, Power, and Ground). This functionality is enabled by driving TEST1 and CFG_SEL[1] high, driving SCLK low and transition RESET_N from low to high. The output from the XNOR chain is driven to GR2 . For each pin tested for continuity GR2 should toggle.

Chapter 8 DC Parameters

8.1 Maximum Guaranteed Ratings

PARAMETER	SYMBOL	MIN	MAX	UNITS	COMMENTS
Storage Temperature	T_A	-55	150	°C	
Lead Temperature			325	°C	Soldering < 10 seconds
1.8V supply voltage	$V_{DDA18PLL}$ V_{DD18}	-0.5	2.5	V	
3.3V supply voltage	V_{DDA33} $V_{DDA33PLL}$ V_{DD33}	-0.5	4.0	V	
Voltage on any I/O pin		-0.5	$(3.3V \text{ supply voltage} + 2) \leq 6$	V	
Voltage on XTAL1		-0.5	4.0	V	
Voltage on XTAL2		-0.5	$V_{DD18} + 0.3V$	V	

Note: Stresses above the specified parameters could cause permanent damage to the device. This is a stress rating only and functional operation of the device at any condition above those indicated in the operation sections of this specification is not implied. When powering this device from laboratory or system power supplies, it is important that the Absolute Maximum Ratings not be exceeded or device failure can result. Some power supplies exhibit voltage spikes on their outputs when the AC power is switched on or off. In addition, voltage transients on the AC power line may appear on the DC output. When this possibility exists, it is suggested that a clamp circuit be used.

8.2 Recommended Operating Conditions

PARAMETER	SYMBOL	MIN	MAX	UNITS	COMMENTS
Operating Temperature	T_A	0	70	°C	
1.8V supply voltage	$V_{DDA18PLL}$ V_{DD18}	1.71	1.98	V	
3.3V supply voltage	V_{DDA33} $V_{DDA33PLL}$ V_{DD33}	3.0	3.6	V	
Voltage on any I/O pin		-0.3	5.5	V	If any 3.3V supply voltage drops below 3.0V, then the MAX becomes: (3.3V supply voltage + 0.5)
Voltage on XTAL1		-0.3	V_{DDA33}	V	
Voltage on XTAL2		-0.3	V_{DD18}	V	

Table 8.1 DC Electrical Characteristics

PARAMETER	SYMBOL	MIN	TYP	MAX	UNITS	COMMENTS
I, IS Type Input Buffer						
Low Input Level	V_{ILI}			0.8	V	TTL Levels
High Input Level	V_{IHI}	2.0			V	
Input Leakage	I_{IL}	-10		+10	uA	$V_{IN} = 0$ to V_{DD33}
Hysteresis ('IS' Only)	V_{HYSI}	250	300	350	mV	
Input Buffer with Pull-Up (IPU)						
Low Input Level	V_{ILI}			0.8	V	TTL Levels
High Input Level	V_{IHI}	2.0			V	
Low Input Leakage	I_{ILL}	+26		+72	uA	$V_{IN} = 0$
High Input Leakage	I_{IHL}	-10		+10	uA	$V_{IN} = V_{DD33}$
Input Buffer with Pull-Down IPD						
Low Input Level	V_{ILI}			0.8	V	TTL Levels
High Input Level	V_{IHI}	2.0			V	
Low Input Leakage	I_{ILL}	+10		-10	uA	$V_{IN} = 0$
High Input Leakage	I_{IHL}	-22		-82	uA	$V_{IN} = V_{DD33}$

Table 8.1 DC Electrical Characteristics (continued)

PARAMETER	SYMBOL	MIN	TYP	MAX	UNITS	COMMENTS
ICLK Input Buffer						
Low Input Level	V_{ILCK}			0.8	V	TTL Levels
High Input Level	V_{IHCK}	2.0			V	
Input Leakage	I_{IL}	-10		+10	μ A	$V_{IN} = 0$ to V_{DD33}
Hysteresis	V_{HYSC}	50		100	mV	
O12 and I/O12 Type Buffer						
Low Output Level	V_{OL}			0.4	V	$I_{OL} = 12\text{mA}$ @ $V_{DD33} = 3.3\text{V}$
High Output Level	V_{OH}	2.4			V	$I_{OH} = -4\text{mA}$ @ $V_{DD33} = 3.3\text{V}$
Output Leakage	I_{OL}			+10	μ A	$V_{IN} = 0$ to V_{DD33} (Note 1)
OD12 Type Buffer						
Low Output Level	V_{OL}			0.4	V	$I_{OL} = 12\text{mA}$ @ $V_{DD33} = 3.3\text{V}$
Output Leakage	I_{OL}	-10		+10	μ A	$V_{IN} = 0$ to V_{DD33} (Note 1)
I/OSD12 Type Buffer						
Low Output Level	V_{OL}			0.4	V	$I_{OL} = 12\text{mA}$ @ $V_{DD33} = 3.3\text{V}$
Output Leakage	I_{OL}	-10		+10	μ A	$V_{IN} = 0$ to V_{DD33} (Note 1)
Hysteresis	V_{HYSI}	250	300	350	mV	
IO-U (Note 2)						
I-R (Note 3)						
Supply Current Unconfigured						
High-Speed Host	I_{CCINIT}		100		mA	
Full-Speed Host	I_{CCINIT}		95		mA	
Supply Current Configured (High-Speed Host)						Total from all supplies
2 Ports @ FS/LS	I_{HCC2}		190		mA	
2 Ports @ HS	I_{HCH2}		235		mA	
1 Port HS, 1 Port FS/LS	I_{HCH1C1}		215		mA	
3 Ports @ HS	I_{HCH3}		265		mA	
4 Ports @ HS	I_{HCC4}		295		mA	

Table 8.1 DC Electrical Characteristics (continued)

PARAMETER	SYMBOL	MIN	TYP	MAX	UNITS	COMMENTS
Supply Current Configured (Full-Speed Host)						Total from all supplies
1 Port	I_{FCC1}		150		mA	
2 Ports	I_{FCC2}		155		mA	
3 Ports	I_{FCC3}		160		mA	
4 Ports	I_{FCC4}		165		mA	
Supply Current Suspend	I_{CSBY}		265		uA	Total from all supplies.
Supply Current Reset	I_{RST}		150		uA	Total from all supplies.

Notes:

1. Output leakage is measured with the current pins in high impedance.
2. See USB 2.0 Specification for USB DC electrical characteristics.
3. RBIAS is a 3.3V tolerant analog pin.

CAPACITANCE $T_A = 25^\circ\text{C}$; $f_c = 1\text{MHz}$; $V_{DD33} = 3.3\text{V}$

PARAMETER	SYMBOL	LIMITS			UNIT	TEST CONDITION
		MIN	TYP	MAX		
Clock Input Capacitance	C_{IN}			12	pF	All pins except USB pins (and pins under test tied to AC ground)
Input Capacitance	C_{IN}			8	pF	
Output Capacitance	C_{OUT}			12	pF	

Power Sequencing

There are no power supply sequence restrictions for the Hub. The order in which power supplies power-up and power-down is implementation dependent.

Chapter 9 AC Specifications

9.1 Oscillator/Clock

Crystal: Parallel Resonant, Fundamental Mode, 24 MHz \pm 100ppm.

External Clock: 50% Duty cycle \pm 10%, 24 MHz \pm 100ppm, Jitter < 100ps rms.

9.1.1 SMBus Interface:

The SMSC Hub conforms to all voltage, power, and timing characteristics and specifications as set forth in the SMBus 1.0 Specification for Slave-Only devices (except as noted in [Section 5.3](#)).

9.1.2 I2C EEPROM:

Frequency is fixed at 59KHz \pm 20%.

9.1.3 USB 2.0

The Hub conforms to all voltage, power, and timing characteristics and specifications as set forth in the USB 2.0 Specification. Please refer to the USB Specification for more information.

Chapter 10 Package Outline

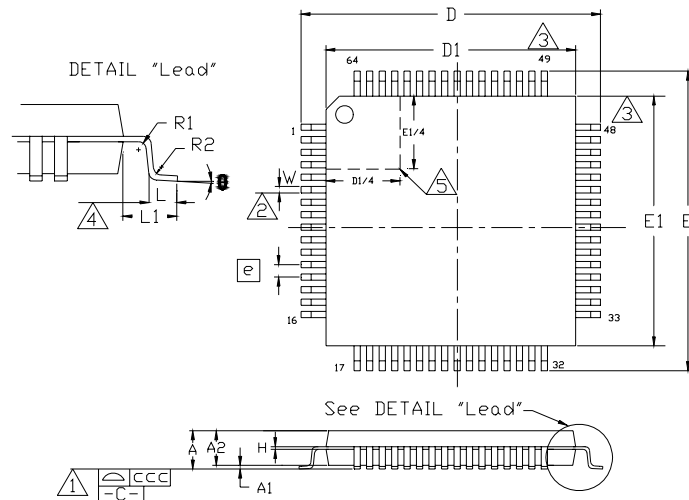

Figure 10.1 64 Pin TQFP Package Outline (10x10x1.4 mm body - 2 mm footprint)

Table 10.1 64 Pin TQFP Package Parameters

	MIN	NOMINAL	MAX	REMARKS
A	~	~	1.60	Overall Package Height
A1	0.05	~	0.15	Standoff
A2	1.35	~	1.45	Body Thickness
D	11.80	~	12.20	X Span
D1	9.80	~	10.20	X body Size
E	11.80	~	12.20	Y Span
E1	9.80	~	10.20	Y body Size
H	0.09	~	0.20	Lead Frame Thickness
L	0.45	0.60	0.75	Lead Foot Length
L1	~	1.00	~	Lead Length
e	0.50 Basic			Lead Pitch
q	0°	~	7°	Lead Foot Angle
W	0.17	0.22	0.27	Lead Width
R1	0.08	~	~	Lead Shoulder Radius
R2	0.08	~	0.20	Lead Foot Radius
ccc	~	~	0.08	Coplanarity

Notes:

- Controlling Unit: millimeter.
- Tolerance on the true position of the leads is ± 0.04 mm maximum.
- Package body dimensions D1 and E1 do not include the mold protrusion. Maximum mold protrusion is 0.25 mm per side.
- Dimension for foot length L measured at the gauge plane 0.25 mm above the seating plane.
- Details of pin 1 identifier are optional but must be located within the zone indicated.

Компания «Океан Электроники» предлагает заключение долгосрочных отношений при поставках импортных электронных компонентов на взаимовыгодных условиях!

Наши преимущества:

- Поставка оригинальных импортных электронных компонентов напрямую с производств Америки, Европы и Азии, а так же с крупнейших складов мира;
- Широкая линейка поставок активных и пассивных импортных электронных компонентов (более 30 млн. наименований);
- Поставка сложных, дефицитных, либо снятых с производства позиций;
- Оперативные сроки поставки под заказ (от 5 рабочих дней);
- Экспресс доставка в любую точку России;
- Помощь Конструкторского Отдела и консультации квалифицированных инженеров;
- Техническая поддержка проекта, помощь в подборе аналогов, поставка прототипов;
- Поставка электронных компонентов под контролем ВП;
- Система менеджмента качества сертифицирована по Международному стандарту ISO 9001;
- При необходимости вся продукция военного и аэрокосмического назначения проходит испытания и сертификацию в лаборатории (по согласованию с заказчиком);
- Поставка специализированных компонентов военного и аэрокосмического уровня качества (Xilinx, Altera, Analog Devices, Intersil, Interpoint, Microsemi, Actel, Aeroflex, Peregrine, VPT, Syfer, Eurofarad, Texas Instruments, MS Kennedy, Miteq, Cobham, E2V, MA-COM, Hittite, Mini-Circuits, General Dynamics и др.);

Компания «Океан Электроники» является официальным дистрибьютором и эксклюзивным представителем в России одного из крупнейших производителей разъемов военного и аэрокосмического назначения «JONHON», а так же официальным дистрибьютором и эксклюзивным представителем в России производителя высокотехнологичных и надежных решений для передачи СВЧ сигналов «FORSTAR».



JONHON

«JONHON» (основан в 1970 г.)

Разъемы специального, военного и аэрокосмического назначения:

(Применяются в военной, авиационной, аэрокосмической, морской, железнодорожной, горно- и нефтедобывающей отраслях промышленности)

«FORSTAR» (основан в 1998 г.)

ВЧ соединители, коаксиальные кабели, кабельные сборки и микроволновые компоненты:

(Применяются в телекоммуникациях гражданского и специального назначения, в средствах связи, РЛС, а так же военной, авиационной и аэрокосмической отраслях промышленности).



Телефон: 8 (812) 309-75-97 (многоканальный)

Факс: 8 (812) 320-03-32

Электронная почта: ocean@oceanchips.ru

Web: <http://oceanchips.ru/>

Адрес: 198099, г. Санкт-Петербург, ул. Калинина, д. 2, корп. 4, лит. А