

Standard Capacitors

GREEN CAP

Anti-cleaning solvent 250V Max.

• Guarantees 2000 hours at 85°C.



High temperature



Marking color : White print on a blue sleeve

Specifications

Item	Performance																																															
Category temperature range (°C)	-40 to +85																																															
Tolerance at rated capacitance (%)	±20 (20°C, 120Hz)																																															
Leakage current (µA)	<table border="1"> <tr> <td>Rated voltage (V)</td> <td>6.3 to 100</td> <td>160 to 450</td> </tr> <tr> <td>Leakage current (µA)</td> <td>Less than 0.03CV or 4 whichever is larger (after 1 minute) Less than 0.01CV or 3 whichever is larger (after 2 minutes)</td> <td>CV ≤ 1000 : Less than 0.1CV + 40 (after 1 minute) CV > 1000 : Less than 0.04CV + 100 (after 1 minute)</td> </tr> </table>	Rated voltage (V)	6.3 to 100	160 to 450	Leakage current (µA)	Less than 0.03CV or 4 whichever is larger (after 1 minute) Less than 0.01CV or 3 whichever is larger (after 2 minutes)	CV ≤ 1000 : Less than 0.1CV + 40 (after 1 minute) CV > 1000 : Less than 0.04CV + 100 (after 1 minute)																																									
	Rated voltage (V)	6.3 to 100	160 to 450																																													
Leakage current (µA)	Less than 0.03CV or 4 whichever is larger (after 1 minute) Less than 0.01CV or 3 whichever is larger (after 2 minutes)	CV ≤ 1000 : Less than 0.1CV + 40 (after 1 minute) CV > 1000 : Less than 0.04CV + 100 (after 1 minute)																																														
C : Rated capacitance (µF) V : Rated voltage (V) (20°C)																																																
Tangent of loss angle (tanδ)	<table border="1"> <tr> <td>Rated voltage (V)</td> <td>6.3</td><td>10</td><td>16</td><td>25</td><td>35</td><td>50</td><td>63</td><td>100</td><td>160</td><td>200</td><td>250</td><td>315</td><td>350</td><td>400</td><td>450</td> </tr> <tr> <td>tanδ (max.)</td> <td>0.28</td><td>0.24</td><td>0.20</td><td>0.16</td><td>0.14</td><td>0.12</td><td>0.10</td><td>0.08</td><td>0.20</td><td>0.20</td><td>0.20</td><td>0.24</td><td>0.24</td><td>0.24</td><td>0.24</td> </tr> </table>	Rated voltage (V)	6.3	10	16	25	35	50	63	100	160	200	250	315	350	400	450	tanδ (max.)	0.28	0.24	0.20	0.16	0.14	0.12	0.10	0.08	0.20	0.20	0.20	0.24	0.24	0.24	0.24															
	Rated voltage (V)	6.3	10	16	25	35	50	63	100	160	200	250	315	350	400	450																																
tanδ (max.)	0.28	0.24	0.20	0.16	0.14	0.12	0.10	0.08	0.20	0.20	0.20	0.24	0.24	0.24	0.24																																	
0.02 is added to every 1000µF increase over 1000µF. (20°C, 120Hz)																																																
Characteristics at high and low temperature	<table border="1"> <tr> <td>Rated voltage (V)</td> <td>6.3</td><td>10</td><td>16</td><td>25</td><td>35</td><td>50</td><td>63</td><td>100</td><td>160</td><td>200</td><td>250</td><td>315</td><td>350</td><td>400</td><td>450</td> </tr> <tr> <td rowspan="2">Impedance ratio (max.)</td> <td>Z-25°C/Z+20°C</td> <td>5</td><td>4</td><td>3</td><td>2</td><td>2</td><td>2</td><td>2</td><td>4</td><td>4</td><td>4</td><td>4</td><td>4</td><td>4</td><td>4</td> </tr> <tr> <td>Z-40°C/Z+20°C</td> <td>12</td><td>10</td><td>8</td><td>5</td><td>4</td><td>3</td><td>3</td><td>3</td><td>15</td><td>15</td><td>15</td><td>10</td><td>10</td><td>10</td> </tr> </table>	Rated voltage (V)	6.3	10	16	25	35	50	63	100	160	200	250	315	350	400	450	Impedance ratio (max.)	Z-25°C/Z+20°C	5	4	3	2	2	2	2	4	4	4	4	4	4	4	Z-40°C/Z+20°C	12	10	8	5	4	3	3	3	15	15	15	10	10	10
	Rated voltage (V)	6.3	10	16	25	35	50	63	100	160	200	250	315	350	400	450																																
Impedance ratio (max.)	Z-25°C/Z+20°C	5	4	3	2	2	2	2	4	4	4	4	4	4	4																																	
	Z-40°C/Z+20°C	12	10	8	5	4	3	3	3	15	15	15	10	10	10																																	
(120Hz)																																																
Endurance (85°C) (Applied ripple current)	Test time	2000 hours																																														
	Leakage current	The initial specified value or less																																														
	Percentage of capacitance change	Within ±20% of initial value																																														
	Tangent of the loss angle	200% or less of the initial specified value																																														
Shelf life (85°C)	Test time : 1000 hours ; other items are the same as those for the endurance. Voltage application treatment : According to JIS C5101 -1																																															
Applicable standards	JIS C5101-1, -4 1998 (IEC 60384-1 1992, -4 1985)																																															

Outline Drawing

Unit : mm

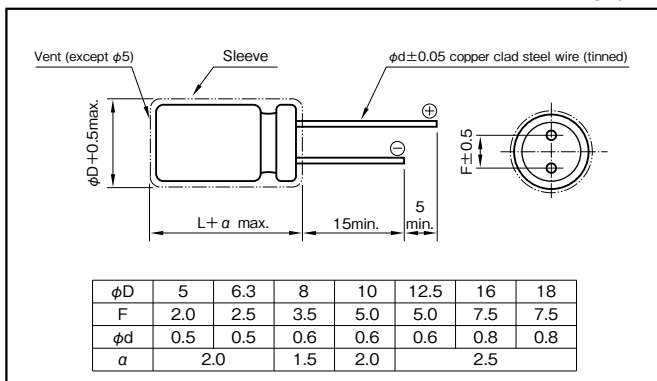

Coefficient of Frequency for Rated Ripple Current

Rated voltage (V)	Frequency (Hz) CV (µF×VV)	50 · 60	120	1k	10k	100k
		6.3 to 16	All CV value	0.8	1	1.1
25 to 35	≤ 1000	0.8	1	1.5	1.7	1.7
	1000 <	0.8	1	1.2	1.3	1.3
50 to 100	≤ 1000	0.8	1	1.6	1.9	1.9
	1000 <	0.8	1	1.2	1.3	1.3
160 to 450	All CV value	0.8	1	1.3	1.5	1.6

Part numbering system (example : 16V1000µF)

RE3	—	16	V	102	M	H4	#	□	—	□
Series code		Rated voltage symbol		Rated capacitance symbol	Capacitance tolerance symbol	Casing symbol	Optional symbol			Taping/Forming symbol

Casing symbol

Size φD×L (mm)	Casing Symbol	Size φD×L (mm)	Casing Symbol
5×11	E3	12.5×25	I6
6.3×11	F3	16×25	J6
8×11.5	G3	16×31.5	J7
10×12.5	H3	16×35.5	J8
10×16	H4	18×31.5	K7
10×20	H5	18×35.5	K8
12.5×20	I5	18×40	K9

Standard Ratings

Rated voltage (V) Rated capacitance (μF)	6.3			10			16			25			35			50			63			100				
	Item	Case	ESR	Rated ripple current	Case	ESR	Rated ripple current	Case	ESR	Rated ripple current	Case	ESR	Rated ripple current	Case	ESR	Rated ripple current	Case	ESR	Rated ripple current	Case	ESR	Rated ripple current	Case	ESR	Rated ripple current	
	φD×L (mm)	(Ω)	(mAmps)	φD×L (mm)	(Ω)	(mAmps)	φD×L (mm)	(Ω)	(mAmps)	φD×L (mm)	(Ω)	(mAmps)	φD×L (mm)	(Ω)	(mAmps)	φD×L (mm)	(Ω)	(mAmps)	φD×L (mm)	(Ω)	(mAmps)	φD×L (mm)	(Ω)	(mAmps)	φD×L (mm)	(Ω)
1	—	—	—	—	—	—	—	—	—	—	—	—	—	—	—	—	5×11	199	21	—	—	—	5×11	133	21	
2.2	—	—	—	—	—	—	—	—	—	—	—	—	—	—	—	—	5×11	90.5	31	—	—	—	5×11	60.3	30	
3.3	—	—	—	—	—	—	—	—	—	—	—	—	—	—	—	—	5×11	60.3	38	—	—	—	5×11	40.2	40	
4.7	—	—	—	—	—	—	—	—	—	5×11	56.5	38	5×11	49.4	40	5×11	42.3	45	5×11	35.3	45	5×11	28.2	45		
10	—	—	—	—	—	—	5×11	33.2	50	5×11	26.5	55	5×11	23.2	59	5×11	19.9	66	5×11	16.6	66	6.3×11	13.3	75		
22	—	—	—	—	—	—	5×11	15.1	75	5×11	12.1	82	5×11	10.6	87	5×11	9.1	98	5×11	7.5	100	6.3×11	6.0	130		
33	—	—	—	—	—	—	5×11	10.1	92	5×11	8.0	100	5×11	7.0	107	5×11	6.0	126	6.3×11	5.0	140	8×11.5	4.0	180		
47	—	—	—	5×11	8.5	99	5×11	7.1	110	5×11	5.7	118	5×11	4.9	130	6.3×11	4.2	155	6.3×11	3.5	170	10×12.5	2.8	230		
100	—	—	—	5×11	3.8	146	5×11	3.3	160	6.3×11	2.7	199	6.3×11	2.3	214	8×11.5	2.0	260	10×12.5	1.7	300	10×20	1.3	370		
220	5×11	2.1	200	6.3×11	1.8	240	6.3×11	1.5	264	8×11.5	1.2	349	10×12.5	1.1	443	10×12.5	0.91	443	10×16	0.75	470	12.5×20	0.60	620		
330	6.3×11	1.4	270	6.3×11	1.2	290	8×11.5	1.0	383	10×12.5	0.81	510	10×12.5	0.70	542	10×16	0.60	595	10×20	0.50	710	12.5×25	0.40	760		
470	6.3×11	0.99	322	8×11.5	0.85	417	8×11.5	0.71	457	10×12.5	0.57	545	10×16	0.49	664	12.5×20	0.42	887	12.5×20	0.35	900	16×25	0.28	1000		
1000	8×11.5	0.47	546	10×12.5	0.40	650	10×16	0.33	791	10×20	0.27	996	12.5×20	0.23	1210	12.5×25	0.20	1400	16×25	0.17	1300	18×40	0.13	1380		
2200	10×20	0.23	1010	10×20	0.20	1080	12.5×20	0.17	1350	12.5×25	0.14	1660	16×25	0.12	1950	16×35.5	0.11	2340	—	—	—	—	—	—	—	
3300	10×20	0.16	1230	12.5×20	0.14	1430	12.5×25	0.12	1690	16×25	0.10	2030	16×35.5	0.090	2510	18×35.5	0.080	2810	—	—	—	—	—	—	—	
4700	12.5×20	0.12	1710	12.5×25	0.11	1780	16×25	0.092	2100	16×31.5	0.078	2650	18×35.5	0.071	2990	—	—	—	—	—	—	—	—	—	—	
6800	12.5×25	0.093	1930	16×25	0.083	2200	16×35.5	0.073	2580	18×35.5	0.063	3290	—	—	—	—	—	—	—	—	—	—	—	—	—	
10000	16×25	0.076	2450	16×35.5	0.070	2700	18×35.5	0.063	3130	—	—	—	—	—	—	—	—	—	—	—	—	—	—	—	—	
15000	16×35.5	0.062	2860	18×35.5	0.058	3100	—	—	—	—	—	—	—	—	—	—	—	—	—	—	—	—	—	—	—	
22000	18×40	0.053	3340	—	—	—	—	—	—	—	—	—	—	—	—	—	—	—	—	—	—	—	—	—	—	

Rated voltage (V) Rated capacitance (μF)	160			200			250			315			350			400			450						
	Item	Case	ESR	Rated ripple current	Case	ESR	Rated ripple current	Case	ESR	Rated ripple current	Case	ESR	Rated ripple current	Case	ESR	Rated ripple current	Case	ESR	Rated ripple current	Case	ESR	Rated ripple current			
	φD×L (mm)	(Ω)	(mAmps)	φD×L (mm)	(Ω)	(mAmps)	φD×L (mm)	(Ω)	(mAmps)	φD×L (mm)	(Ω)	(mAmps)	φD×L (mm)	(Ω)	(mAmps)	φD×L (mm)	(Ω)	(mAmps)	φD×L (mm)	(Ω)	(mAmps)	φD×L (mm)	(Ω)	(mAmps)	
0.47	6.3×11	706	15	6.3×11	706	15	6.3×11	706	15	6.3×11	847	15	6.3×11	847	15	6.3×11	847	15	8×11.5	847	18				
1	6.3×11	332	22	6.3×11	332	22	6.3×11	332	22	6.3×11	398	22	6.3×11	398	22	6.3×11	398	22	8×11.5	398	25				
2.2	6.3×11	151	32	6.3×11	151	32	6.3×11	151	32	8×11.5	181	38	8×11.5	181	38	8×11.5	181	38	10×12.5	181	43				
3.3	6.3×11	101	40	6.3×11	101	40	8×11.5	101	48	10×12.5	121	53	10×12.5	121	53	10×12.5	121	54	10×16	121	59				
4.7	6.3×11	70.6	48	8×11.5	70.6	56	8×11.5	70.6	56	10×12.5	84.7	65	10×12.5	84.7	65	10×16	84.7	71	10×20	84.7	76				
10	8×11.5	33.2	81	10×12.5	33.2	94	10×16	33.2	101	10×20	39.8	115	10×20	39.8	115	12.5×20	39.8	123	12.5×20	39.8	123				
22	10×16	15.1	151	10×20	15.1	170	12.5×20	15.1	182	12.5×20	18.1	182	12.5×25	18.1	197	12.5×25	18.1	197	16×25	18.1	226				
33	10×20	10.1	202	12.5×20	10.1	223	12.5×25	10.1	243	16×25	12.1	277	16×25	12.1	277	16×25	12.1	277	16×31.5	12.1	304				
47	12.5×20	7.06	266	12.5×25	7.06	265	12.5×25	7.06	295	16×25	8.47	330	16×25	8.47	330	16×31.5	8.47	361	16×35.5	8.47	380				
100	12.5×25	3.32	422	16×25	3.32	483	16×31.5	3.32	528	18×31.5	3.98	567	18×31.5	3.98	567	—	—	—	—	—	—	—	—	—	
220	16×31.5	1.51	783	18×35.5	1.51	882	—	—	—	—	—	—	—	—	—	—	—	—	—	—	—	—	—	—	
330	18×35.5	1.01	1080	—	—	—	—	—	—	—	—	—	—	—	—	—	—	—	—	—	—	—	—	—	—

(Note) Rated ripple current : 85°C, 120Hz ; ESR : 20°C, 120Hz

Компания «Океан Электроники» предлагает заключение долгосрочных отношений при поставках импортных электронных компонентов на взаимовыгодных условиях!

Наши преимущества:

- Поставка оригинальных импортных электронных компонентов напрямую с производств Америки, Европы и Азии, а так же с крупнейших складов мира;
- Широкая линейка поставок активных и пассивных импортных электронных компонентов (более 30 млн. наименований);
- Поставка сложных, дефицитных, либо снятых с производства позиций;
- Оперативные сроки поставки под заказ (от 5 рабочих дней);
- Экспресс доставка в любую точку России;
- Помощь Конструкторского Отдела и консультации квалифицированных инженеров;
- Техническая поддержка проекта, помощь в подборе аналогов, поставка прототипов;
- Поставка электронных компонентов под контролем ВП;
- Система менеджмента качества сертифицирована по Международному стандарту ISO 9001;
- При необходимости вся продукция военного и аэрокосмического назначения проходит испытания и сертификацию в лаборатории (по согласованию с заказчиком);
- Поставка специализированных компонентов военного и аэрокосмического уровня качества (Xilinx, Altera, Analog Devices, Intersil, Interpoint, Microsemi, Actel, Aeroflex, Peregrine, VPT, Syfer, Eurofarad, Texas Instruments, MS Kennedy, Miteq, Cobham, E2V, MA-COM, Hittite, Mini-Circuits, General Dynamics и др.);

Компания «Океан Электроники» является официальным дистрибьютором и эксклюзивным представителем в России одного из крупнейших производителей разъемов военного и аэрокосмического назначения «JONHON», а так же официальным дистрибьютором и эксклюзивным представителем в России производителя высокотехнологичных и надежных решений для передачи СВЧ сигналов «FORSTAR».



JONHON

«JONHON» (основан в 1970 г.)

Разъемы специального, военного и аэрокосмического назначения:

(Применяются в военной, авиационной, аэрокосмической, морской, железнодорожной, горно- и нефтедобывающей отраслях промышленности)

«FORSTAR» (основан в 1998 г.)

ВЧ соединители, коаксиальные кабели, кабельные сборки и микроволновые компоненты:

(Применяются в телекоммуникациях гражданского и специального назначения, в средствах связи, РЛС, а так же военной, авиационной и аэрокосмической отраслях промышленности).



Телефон: 8 (812) 309-75-97 (многоканальный)

Факс: 8 (812) 320-03-32

Электронная почта: ocean@oceanchips.ru

Web: <http://oceanchips.ru/>

Адрес: 198099, г. Санкт-Петербург, ул. Калинина, д. 2, корп. 4, лит. А