

**RoHS Compliant**

## **Serial ATA Flash Drive**

SS210-18 Product Specifications (Toshiba 24nm)

**February 23, 2018**

**Version 1.0**



**Apacer Technology Inc.**

1F, No.32, Zhongcheng Rd., Tucheng Dist., New Taipei City, Taiwan, R.O.C

Tel: +886-2-2267-8000 Fax: +886-2-2267-2261

[www.apacer.com](http://www.apacer.com)

## Features:

- **Compliance with SATA Revision 3.1**
  - SATA 6.0 Gbps interface
  - Backward compatible with SATA 1.5 and 3.0 Gbps interfaces
  - ATA-8 command set
- **Capacity**
  - 32, 64, 128, 240 GB
- **Performance\***
  - Burst read/write: 600 MB/sec
  - Sequential read: Up to 525 MB/sec
  - Sequential write: Up to 440 MB/sec
  - Seq. read QD32: Up to 560 MB/sec
  - Seq. write QD32: Up to 440 MB/sec
  - Random read (4K): Up to 82,000 IOPS
  - Random write (4K): Up to 76,000 IOPS
- **Flash Management**
  - Built-in hardware ECC
  - Global Wear Leveling
  - Flash bad-block management
  - S.M.A.R.T.
  - Power Failure Management
  - ATA Secure Erase
  - TRIM
- **DRAM Cache for Enhanced Random Performance**
- **SATA Power Management Mode**
- **NAND Flash Type: SLC**
- **MTBF: >2,000,000 hours**
- **Temperature Range**
  - Operating:
    - Standard: 0°C to 70°C
    - Extended: -40°C to 85°C
  - Storage: -40°C to 100°C
- **Supply Voltage**
  - 3.3V & 5V
- **Power Consumption\***
  - @3.3V
    - Active mode: 750 mA
    - Idle mode: 105 mA
  - @5V
    - Active mode: 495 mA
    - Idle mode: 70 mA
- **Form Factor**
  - 1.8 inch
  - Dimensions: 78.50 x 54.00 x 5.00, unit: mm
- **Connector Type**
  - 7-pin SATA male connector
  - 9-pin SATA power connector
- **Shock & Vibration\*\***
  - Shock: 1,500 G
  - Vibration: 15 G
- **Device Sleep Mode (optional)**
- **RoHS Compliant**

\*Varies from capacities. The values for performances and power consumptions presented are typical and may vary depending on flash configurations or platform settings. The term idle refers to the standby state of the device.

\*\*Non-operating

## Table of Contents

<b>1. General Descriptions .....</b>	<b>3</b>
1.1 Introduction .....	3
1.2 Capacity Specifications .....	3
1.3 Performance .....	3
1.4 Pin Assignments .....	4
<b>2. Software Interface .....</b>	<b>6</b>
2.1 Command Set .....	6
2.2 S.M.A.R.T. ....	6
<b>3. Flash Management .....</b>	<b>8</b>
3.1 Error Correction/Detection .....	8
3.2 Bad Block Management .....	8
3.3 Global Wear Leveling .....	8
3.4 Power Failure Management .....	8
3.5 ATA Secure Erase .....	8
3.6 TRIM .....	9
3.7 SATA Power Management .....	9
<b>4. Reliability Specifications .....</b>	<b>10</b>
4.1 Environmental Specifications .....	10
4.2 Mean Time Between Failures (MTBF) .....	10
4.3 Certification and Compliance .....	10
<b>5. Electrical Specifications .....</b>	<b>11</b>
5.1 Operating Voltage .....	11
5.2 Power Consumption .....	11
<b>6. Physical Characteristics .....</b>	<b>12</b>
<b>7. Product Ordering Information .....</b>	<b>13</b>
7.1 Product Code Designations .....	13
7.2 Valid Combinations .....	14

# 1. General Descriptions

## 1.1 Introduction

Apacer's SS210-18 is a well-balanced solid-state disk (SSD) drive with standard form factor and great performance. Designed in SATA 6.0 Gbps interface, the SSD is able to deliver exceptional read/write speed, making it the ideal companion for heavy-loading industrial or server operations. In regard of reliability, the drive comes with various implementations including powerful hardware ECC engine, power saving modes, wear leveling, flash block management, S.M.A.R.T., TRIM, and power failure management.

## 1.2 Capacity Specifications

Capacity specifications of SS210-18 are available as shown in Table 1-1. It lists the specific capacity and the default numbers of heads, sectors and cylinders for each product line.

**Table 1-1** Capacity Specifications

Capacity	Total bytes*	Cylinders	Heads	Sectors	Max LBA
32 GB	32,017,047,552	16,383	16	63	62,533,296
64 GB	64,023,257,088	16,383	16	63	125,045,424
128 GB	128,035,676,160	16,383	16	63	250,069,680
240 GB	256,060,514,304	16,383	16	63	500,118,192

\*Display of total bytes varies from file systems, which means not all of the bytes can be used for storage.

\*\*Notes: 1 GB = 1,000,000,000 bytes; 1 sector = 512 bytes.

LBA count addressed in the table above indicates total user storage capacity and will remain the same throughout the lifespan of the device. However, the total usable capacity of the SSD is most likely to be less than the total physical capacity because a small portion of the capacity is reserved for device maintenance usages.

## 1.3 Performance

Performance of SS210-18 is listed below in Table 1-2.

**Table 1-2** Performance Specifications

Capacity	32 GB	64 GB	128 GB	240 GB
<b>Performance</b>				
<b>Sequential Read* (MB/s)</b>	525	520	525	310
<b>Sequential Write* (MB/s)</b>	245	425	440	430
<b>Seq. Read QD32* (MB/s)</b>	560	555	555	320
<b>Seq. Write QD32* (MB/s)</b>	250	430	440	430
<b>Random Read IOPS** (4K)</b>	79,000	82,000	81,000	52,000
<b>Random Write IOPS** (4K)</b>	61,000	74,000	76,000	75,000

Note:

Results may differ from various flash configurations or host system setting.

\*Sequential performance is based on CrystalDiskMark 5.2.1 with file size 1,000MB.

\*\*Random performance measured using IOMeter with Queue Depth 32.

## 1.4 Pin Assignments

Table 1-3 describes SS210-18 signal segment, and Table 1-4, its power segment.

**Figure 1-1** Micro-SATA Connectors



**Table 1-3** Signal Segment

Name	Type	Description
S1	GND	
S2	RxP	+ Differential Receive Signal
S3	RxN	- Differential Receive Signal
S4	GND	
S5	TxN	- Differential Transmit Signal
S6	TxP	+ Differential Transmit Signal
S7	GND	

**Table 1-4** Power Segment

Pin	Type	Signal/Description
P1	V33	3.3 V Power
P2	V33	3.3 V Power
P3	GND	
P4	GND	
P5	V5	5 V Power
P6	V5	5 V Power
P7	GND	Reserved
P8	Optional	NC
P9	Optional	DEVSLP



**Figure 1-2** SATA Cable/Connector Connection Diagram

The connector on the left represents the Host with TX/RX differential pairs connected to a cable. The connector on the right shows the Device with TX/RX differential pairs also connected to the cable. Notice also the ground path connecting the shielding of the cable to the Cable Receptacle.

## 2. Software Interface

### 2.1 Command Set

Table 2-1 summarizes the ATA commands supported by SS210-18.

**Table 2-1** Command Set

Code	Command	Code	Command
E5h	Check Power Mode	F6h	Security Disable Password
90h	Execute Diagnostics	F3h	Security Erase Prepare
E7h	Flush Cache	F4h	Security Erase Unit
ECh	Identify Device	F5h	Security Freeze Lock
E3h	Idle	F1h	Security Set Password
E1h	Idle Immediate	F2h	Security Unlock
91h	Initialize Device Parameters	7Xh	Seek
C8h	Read DMA	EFh	Set Features
25h	Read DMA EXT	C6h	Set Multiple Mode
60h	Read FPDMA Queued	E6h	Sleep
47h	Read Log DMA EXT	B0h	S.M.A.R.T.
2Fh	Read Log EXT	E2h	Standby
C4h	Read Multiple	E0h	Standby Immediate
20 or 21h	Read Sector(s)	CAh	Write DMA
40 or 41h	Read Verify Sector(s)	35h	Write DMA EXT
10h	Recalibrate	61h	Write FPDMA Queued
57h	Write Log DMA EXT	3Fh	Write Log EXT
C5h	Write Multiple	30h or 31h	Write Sector(s)

### 2.2 S.M.A.R.T.

S.M.A.R.T. is an abbreviation for Self-Monitoring, Analysis and Reporting Technology, a self-monitoring system that provides indicators of drive health as well as potential disk problems. It serves as a warning for users from unscheduled downtime by monitoring and displaying critical drive information. Ideally, this should allow taking proactive actions to prevent drive failure and make use of S.M.A.R.T. information for future product development reference.

Apacer devices use the standard SMART command B0h to read data out from the drive to activate our S.M.A.R.T. feature that complies with the ATA/ATAPI specifications. S.M.A.R.T. Attribute IDs shall include initial bad block count, total later bad block count, maximum erase count, average erase count, power on hours and power cycle. When the S.M.A.R.T. Utility running on the host, it analyzes and reports the disk status to the host before the device reaches in critical condition.

Note: Attribute IDs may vary from product models due to various solution design and supporting capabilities.

Apacer memory products come with S.M.A.R.T. commands and subcommands for users to obtain information of drive status and to predict potential drive failures. Users can take advantage of the following commands/subcommands to monitor the health of the drive.

Code	SMART Subcommand
D0h	READ DATA
D1h	READ ATTRIBUTE THRESHOLDS
D2h	Enable/Disable Attribute Autosave
D4h	Execute Off-line Immediate
D5h	Read Log (optional)
D6h	Write Log (optional)
D8h	Enable Operations
D9h	Disable operations
DAh	Return Status

### General SMART attribute structure

Byte	Description
0	ID (Hex)
1 – 2	Status flag
3	Value
4	Worst
5*-11	Raw Data

\*Byte 5: LSB

### SMART attribute ID list

ID (Hex)	Attribute Name
9 (0x09)	Power-on hours
12 (0x0C)	Power cycle count
163 (0xA3)	Max. erase count
164 (0xA4)	Avg. erase count
166 (0xA6)	Total later bad block count
167 (0xA7)	SSD Protect Mode (vendor specific)
168 (0xA8)	SATA PHY Error Count
175 (0xAF)	Bad Cluster Table Count
192 (0xC0)	Unexpected Power Loss Count
194 (0xC2)	Temperature
241 (0xF1)	Total sectors of write



## 3. Flash Management

### 3.1 Error Correction/Detection

SS210-18 implements a hardware ECC scheme, based on the BCH algorithm. It can detect and correct up to 72 bit error in 1K bytes.

### 3.2 Bad Block Management

Current production technology is unable to guarantee total reliability of NAND flash memory array. When a flash memory device leaves factory, it comes with a minimal number of initial bad blocks during production or out-of-factory as there is no currently known technology that produce flash chips free of bad blocks. In addition, bad blocks may develop during program/erase cycles. When host performs program/erase command on a block, bad block may appear in Status Register. Since bad blocks are inevitable, the solution is to keep them in control. Apacer flash devices are programmed with ECC, page mapping technique and S.M.A.R.T to reduce invalidity or error. Once bad blocks are detected, data in those blocks will be transferred to free blocks and error will be corrected by designated algorithms.

### 3.3 Global Wear Leveling

Flash memory devices differ from Hard Disk Drives (HDDs) in terms of how blocks are utilized. For HDDs, when a change is made to stored data, like erase or update, the controller mechanism on HDDs will perform overwrites on blocks. Unlike HDDs, flash blocks cannot be overwritten and each P/E cycle wears down the lifespan of blocks gradually. Repeatedly program/erase cycles performed on the same memory cells will eventually cause some blocks to age faster than others. This would bring flash storages to their end of service term sooner. Global wear leveling is an important mechanism that levels out the wearing of all blocks so that the wearing-down of all blocks can be almost evenly distributed. This will increase the lifespan of SSDs.

### 3.4 Power Failure Management

Power Failure Management plays a crucial role when experiencing unstable power supply. Power disruption may occur when users are storing data into the SSD. In this urgent situation, the controller would run multiple write-to-flash cycles to store the metadata for later block rebuilding. This urgent operation requires about several milliseconds to get it done. At the next power up, the firmware will perform a status tracking to retrieve the mapping table and resume previously programmed NAND blocks to check if there is any incompleteness of transmission.

Note: The controller unit of this product model is designed with a DRAM as a write cache for improved performance and data efficiency. Though unlikely to happen in most cases, the data cached in the volatile DRAM might be potentially affected if a sudden power loss takes place before the cached data is flushed into non-volatile NAND flash memory.

### 3.5 ATA Secure Erase

ATA Secure Erase is an ATA disk purging command currently embedded in most of the storage drives. Defined in ATA specifications, (ATA) Secure Erase is part of Security Feature Set that allows storage drives to erase all user data areas. The erase process usually runs on the firmware level as most of the ATA-based storage media currently in the market are built-in with this command. ATA Secure Erase can securely wipe out the user data in the drive and protects it from malicious attack.

## 3.6 TRIM

TRIM is a SATA command that helps improve the read/write performance and efficiency of solid-state drives (SSD). The command enables the host operating system to inform SSD controller which blocks contain invalid data, mostly because of the erase commands from host. The invalid will be discarded permanently and the SSD will retain more space for itself.

## 3.7 SATA Power Management

By complying with SATA 6.0 Gb/s specifications, the SSD supports the following SATA power saving modes:

- ACTIVE: PHY ready, full power, Tx & Rx operational
- PARTIAL: Reduces power, resumes in under 10  $\mu$ s (microseconds)
- SLUMBER: Reduces power, resumes in under 10 ms (milliseconds)
- HIPM: Host-Initiated Power Management
- DIPM: Device-Initiated Power Management
- AUTO-SLUMBER: Automatic transition from partial to slumber.

Note:

1. The behaviors of power management features would depend on host/device settings.
2. Device Sleep mode is optional, depending on product ordering selections.

## 4. Reliability Specifications

### 4.1 Environmental Specifications

Environmental specifications of SS210-18 product are shown in Table 4-1.

**Table 4-1** Environmental Specifications

Environment	Specifications
Temperature	0°C to 70°C (Operating); -40°C to 85°C (Extended)
	-40°C to 100°C (Non-operating)
Vibration	Non-operating: Sine wave, 15(G), 10~2000(Hz), Operating: Random, 7.69(Grms), 20~2000(Hz)
Shock	Non-operating: Acceleration, 1,500 G, 0.5 ms Operating: Peak acceleration, 50 G, 11 ms

### 4.2 Mean Time Between Failures (MTBF)

Mean Time Between Failures (MTBF) is predicted based on reliability data for the individual components in SS210-18. The prediction result for SS210-18 is more than 2,000,000 hours.

Note: The MTBF is predicated and calculated based on “Telcordia Technologies Special Report, SR-332, Issue 2” method.

### 4.3 Certification and Compliance

SS210-18 complies with the following standards:

- CE
- FCC
- RoHS Recast
- MIL-STD-810F

## 5. Electrical Specifications

### 5.1 Operating Voltage

Table 5-1 lists the supply voltage for SS210-18.

**Table 5-1** Operating Voltage

Item	Range
Supply Voltage	3.3V ± 5% (3.135-3.465V) 5V ± 5% (4.75-5.25V)

### 5.2 Power Consumption

Table 5-2 lists the power consumption for SS210-18.

**Table 5-2** Power Consumption @ 3.3V

Mode \ Capacity	32 GB	64 GB	128 GB	240 GB
Active (mA)	445	655	690	750
Idle (mA)	100	100	100	105

**Table 5-3** Power Consumption @ 5V

Mode \ Capacity	32 GB	64 GB	128 GB	240 GB
Active (mA)	295	435	460	495
Idle (mA)	70	70	70	70

Note:

\*All values are typical and may vary depending on flash configurations or host system settings.

\*\*Active power is an average power measurement performed using CrystalDiskMark with 128KB sequential read/write transfers.

## 6. Physical Characteristics

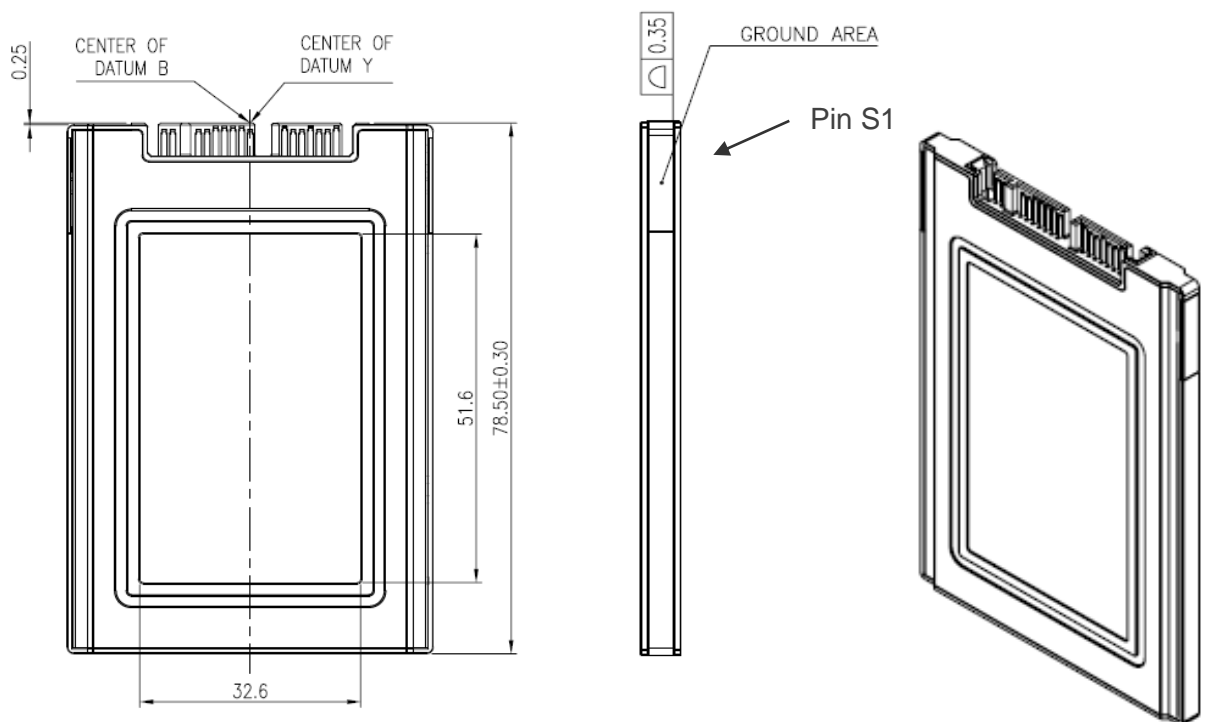

Unit: mm  
Tolerance:  $\pm 0.2$

## 7. Product Ordering Information

### 7.1 Product Code Designations



## 7.2 Valid Combinations

### 7.2.1 3.3V / Operating Temperature (0°C ~ 70°C)

Capacity	No DEVSLP	DEVSLP
32GB	APS18AFA032G-4ATL	APS18AFA032G-4BTL
64GB	APS18AFA064G-4ATL	APS18AFA064G-4BTL
128GB	APS18AFA128G-4ATL	APS18AFA128G-4BTL
240GB	APS18AFA240G-4ETL	APS18AFA240G-4FTL

### 7.2.2 3.3V / Operating Temperature (-40°C ~ 85°C)

Capacity	No DEVSLP	DEVSLP
32GB	APS18AFA032G-4ATWL	APS18AFA032G-4BTWL
64GB	APS18AFA064G-4ATWL	APS18AFA064G-4BTWL
128GB	APS18AFA128G-4ATWL	APS18AFA128G-4BTWL
240GB	APS18AFA240G-4ETWL	APS18AFA240G-4FTWL

### 7.2.3 5V / Operating Temperature (0°C ~ 70°C)

Capacity	No DEVSLP	DEVSLP
32GB	APS18AFA032G-4AT	APS18AFA032G-4BT
64GB	APS18AFA064G-4AT	APS18AFA064G-4BT
128GB	APS18AFA128G-4AT	APS18AFA128G-4BT
240GB	APS18AFA240G-4ET	APS18AFA240G-4FT

### 7.2.4 5V / Operating Temperature (-40°C ~ 85°C)

Capacity	No DEVSLP	DEVSLP
32GB	APS18AFA032G-4ATW	APS18AFA032G-4BTW
64GB	APS18AFA064G-4ATW	APS18AFA064G-4BTW
128GB	APS18AFA128G-4ATW	APS18AFA128G-4BTW
240GB	APS18AFA240G-4ETW	APS18AFA240G-4FTW

**Note:** Valid combinations are those products in mass production or will be in mass production. Consult your Apacer sales representative to confirm availability of valid combinations and to determine availability of new combinations.

## Revision History

Revision	Date	Description	Remark
1.0	2/23/2018	Official release	



## Global Presence

### Taiwan (Headquarters)

#### Apacer Technology Inc.

1F., No.32, Zhongcheng Rd., Tucheng Dist.,  
New Taipei City 236, Taiwan R.O.C.  
Tel: 886-2-2267-8000  
Fax: 886-2-2267-2261  
[amtsales@apacer.com](mailto:amtsales@apacer.com)

### U.S.A.

#### Apacer Memory America, Inc.

46732 Lakeview Blvd., Fremont, CA 94538  
Tel: 1-408-518-8699  
Fax: 1-510-249-9551  
[sa@apacerus.com](mailto:sa@apacerus.com)

### Japan

#### Apacer Technology Corp.

6F, Daiyontamachi Bldg., 2-17-12, Shibaura, Minato-Ku,  
Tokyo, 108-0023, Japan  
Tel: 81-3-5419-2668  
Fax: 81-3-5419-0018  
[jpservices@apacer.com](mailto:jpservices@apacer.com)

### Europe

#### Apacer Technology B.V.

Science Park Eindhoven 5051 5692 EB Son,  
The Netherlands  
Tel: 31-40-267-0000  
Fax: 31-40-290-0686  
[sales@apacer.nl](mailto:sales@apacer.nl)

### China

#### Apacer Electronic (Shanghai) Co., Ltd

Room D, 22/FL, No.2, Lane 600, JieyunPlaza,  
Tianshan RD, Shanghai, 200051, China  
Tel: 86-21-6228-9939  
Fax: 86-21-6228-9936  
[sales@apacer.com.cn](mailto:sales@apacer.com.cn)

### India

#### Apacer Technologies Pvt Ltd,

Unit No.201, "Brigade Corner", 7<sup>th</sup> Block  
Jayanagar,  
Yediyur Circle, Bangalore – 560082, India  
Tel: 91-80-4152-9061  
Fax: 91-80-4170-0215  
[sales\\_india@apacer.com](mailto:sales_india@apacer.com)

Компания «Океан Электроники» предлагает заключение долгосрочных отношений при поставках импортных электронных компонентов на взаимовыгодных условиях!

Наши преимущества:

- Поставка оригинальных импортных электронных компонентов напрямую с производств Америки, Европы и Азии, а так же с крупнейших складов мира;
- Широкая линейка поставок активных и пассивных импортных электронных компонентов (более 30 млн. наименований);
- Поставка сложных, дефицитных, либо снятых с производства позиций;
- Оперативные сроки поставки под заказ (от 5 рабочих дней);
- Экспресс доставка в любую точку России;
- Помощь Конструкторского Отдела и консультации квалифицированных инженеров;
- Техническая поддержка проекта, помощь в подборе аналогов, поставка прототипов;
- Поставка электронных компонентов под контролем ВП;
- Система менеджмента качества сертифицирована по Международному стандарту ISO 9001;
- При необходимости вся продукция военного и аэрокосмического назначения проходит испытания и сертификацию в лаборатории (по согласованию с заказчиком);
- Поставка специализированных компонентов военного и аэрокосмического уровня качества (Xilinx, Altera, Analog Devices, Intersil, Interpoint, Microsemi, Actel, Aeroflex, Peregrine, VPT, Syfer, Eurofarad, Texas Instruments, MS Kennedy, Miteq, Cobham, E2V, MA-COM, Hittite, Mini-Circuits, General Dynamics и др.);

Компания «Океан Электроники» является официальным дистрибьютором и эксклюзивным представителем в России одного из крупнейших производителей разъемов военного и аэрокосмического назначения «JONHON», а так же официальным дистрибьютором и эксклюзивным представителем в России производителя высокотехнологичных и надежных решений для передачи СВЧ сигналов «FORSTAR».



## JONHON

«JONHON» (основан в 1970 г.)

Разъемы специального, военного и аэрокосмического назначения:

(Применяются в военной, авиационной, аэрокосмической, морской, железнодорожной, горно- и нефтедобывающей отраслях промышленности)

«FORSTAR» (основан в 1998 г.)

ВЧ соединители, коаксиальные кабели, кабельные сборки и микроволновые компоненты:

(Применяются в телекоммуникациях гражданского и специального назначения, в средствах связи, РЛС, а так же военной, авиационной и аэрокосмической отраслях промышленности).



Телефон: 8 (812) 309-75-97 (многоканальный)

Факс: 8 (812) 320-03-32

Электронная почта: [ocean@oceanchips.ru](mailto:ocean@oceanchips.ru)

Web: <http://oceanchips.ru/>

Адрес: 198099, г. Санкт-Петербург, ул. Калинина, д. 2, корп. 4, лит. А