

High-side driver with MultiSense analog feedback for automotive applications

Datasheet - production data



- Loss of ground and loss of V_{CC}
- Reverse battery with external components
- Electrostatic discharge protection

Applications

- All types of Automotive resistive, inductive and capacitive loads
- Specially intended for Automotive Headlamps

Features

Max transient supply voltage	V_{CC}	40 V
Operating voltage range	V_{CC}	4 to 28 V
Typ. on-state resistance (per Ch)	R_{ON}	16 m Ω
Current limitation (typ)	I_{LIMH}	77 A
Standby current (max)	I_{STBY}	0.5 μ A

- Automotive qualified
- General
 - Single channel smart high-side driver with MultiSense analog feedback
 - Very low standby current
 - Compatible with 3 V and 5 V CMOS outputs
- MultiSense diagnostic functions
 - Multiplexed analog feedback of: load current with high precision proportional current mirror, V_{CC} supply voltage and T_{CHIP} device temperature
 - Overload and short to ground (power limitation) indication
 - Thermal shutdown indication
 - OFF-state open-load detection
 - Output short to V_{CC} detection
 - Sense enable/disable
- Protections
 - Undervoltage shutdown
 - Overvoltage clamp
 - Load current limitation
 - Self limiting of fast thermal transients
 - Configurable latch-off on overtemperature or power limitation with dedicated fault reset pin

Description

The device is a single channel high-side driver manufactured using ST proprietary VIPower® M0-7 technology and housed in PowerSSO-16 package. The device is designed to drive 12 V automotive grounded loads through a 3 V and 5 V CMOS-compatible interface, providing protection and diagnostics.

The device integrates advanced protective functions such as load current limitation, overload active management by power limitation and overtemperature shutdown with configurable latch-off.

A $\overline{\text{FaultRST}}$ pin unlatches the output in case of fault or disables the latch-off functionality.

A dedicated multifunction multiplexed analog output pin delivers sophisticated diagnostic functions including high precision proportional load current sense, supply voltage feedback and chip temperature sense, in addition to the detection of overload and short circuit to ground, short to V_{CC} and OFF-state open-load.

A sense enable pin allows OFF-state diagnosis to be disabled during the module low-power mode as well as external sense resistor sharing among similar devices.

Contents

1	Block diagram and pin description	5
2	Electrical specification.....	7
2.1	Absolute maximum ratings.....	7
2.2	Thermal data.....	8
2.3	Main electrical characteristics	8
2.4	Waveforms.....	19
2.5	Electrical characteristics curves	21
3	Protections.....	25
3.1	Power limitation.....	25
3.2	Thermal shutdown.....	25
3.3	Current limitation	25
3.4	Negative voltage clamp.....	25
4	Application information	26
4.1	GND protection network against reverse battery.....	26
4.1.1	Diode (DGND) in the ground line	27
4.2	Immunity against transient electrical disturbances.....	27
4.3	MCU I/Os protection.....	27
4.4	Multisense - analog current sense	28
4.4.1	Principle of Multisense signal generation.....	29
4.4.2	TCASE and VCC monitor.....	31
4.4.3	Short to VCC and OFF-state open-load detection	32
5	Maximum demagnetization energy (VCC = 16 V)	34
6	Package and PCB thermal data.....	35
6.1	PowerSSO-16 thermal data	35
7	Package information	38
7.1	PowerSSO-16 package information	38
7.2	PowerSSO-16 packing information	40
7.3	PowerSSO-16 marking information.....	42
8	Order codes	43
9	Revision history	44

List of tables

Table 1: Pin functions	5
Table 2: Suggested connections for unused and not connected pins.....	6
Table 3: Absolute maximum ratings	7
Table 4: Thermal data.....	8
Table 5: Power section	8
Table 6: Switching.....	9
Table 7: Logic inputs.....	10
Table 8: Protections	11
Table 9: MultiSense	11
Table 10: Truth table.....	18
Table 11: MultiSense multiplexer addressing.....	18
Table 12: ISO 7637-2 - electrical transient conduction along supply line.....	27
Table 13: MultiSense pin levels in off-state	31
Table 14: PCB properties	35
Table 15: Thermal parameters	37
Table 16: PowerSSO-16 mechanical data.....	38
Table 17: Reel dimensions	40
Table 18: PowerSSO-16 carrier tape dimensions	41
Table 19: Device summary	43
Table 20: Document revision history	44

List of figures

Figure 1: Block diagram.....	5
Figure 2: Configuration diagram (top view).....	6
Figure 3: Current and voltage conventions.....	7
Figure 4: IOOUT/ISENSE versus IOOUT.....	15
Figure 5: Current sense accuracy versus IOOUT.....	15
Figure 6: Switching time and Pulse skew.....	16
Figure 7: MultiSense timings (current sense mode).....	16
Figure 8: Multisense timings (chip temperature and VCC sense mode).....	17
Figure 9: TDSTKON.....	17
Figure 10: Latch functionality - behavior in hard short circuit condition (TAMB << TTSD).....	19
Figure 11: Latch functionality - behavior in hard short circuit condition.....	19
Figure 12: Latch functionality - behavior in hard short circuit condition (autorestart mode + latch off)....	20
Figure 13: Standby mode activation.....	20
Figure 14: Standby state diagram.....	21
Figure 15: OFF-state output current.....	21
Figure 16: Standby current.....	21
Figure 17: IGND(ON) vs. Iout.....	22
Figure 18: Logic Input high level voltage.....	22
Figure 19: Logic Input low level voltage.....	22
Figure 20: High level logic input current.....	22
Figure 21: Low level logic input current.....	22
Figure 22: Logic Input hysteresis voltage.....	22
Figure 23: FaultRST Input clamp voltage.....	23
Figure 24: Undervoltage shutdown.....	23
Figure 25: On-state resistance vs. Tcase.....	23
Figure 26: On-state resistance vs. VCC.....	23
Figure 27: Turn-on voltage slope.....	23
Figure 28: Turn-off voltage slope.....	23
Figure 29: Won vs. Tcase.....	24
Figure 30: Woff vs. Tcase.....	24
Figure 31: ILIMH vs. Tcase.....	24
Figure 32: OFF-state open-load voltage detection threshold.....	24
Figure 33: Vsense clamp vs. Tcase.....	24
Figure 34: Vsenseh vs. Tcase.....	24
Figure 35: Application diagram.....	26
Figure 36: Simplified internal structure.....	26
Figure 37: MultiSense and diagnostic – block diagram.....	28
Figure 38: MultiSense block diagram.....	29
Figure 39: Analogue HSD – open-load detection in off-state.....	30
Figure 40: Open-load / short to VCC condition.....	31
Figure 41: GND voltage shift.....	32
Figure 42: Maximum turn off current versus inductance.....	34
Figure 43: PowerSSO-16 on two-layers PCB (2s0p to JEDEC JESD 51-5).....	35
Figure 44: PowerSSO-16 on four-layers PCB (2s2p to JEDEC JESD 51-7).....	35
Figure 45: Rthj-amb vs PCB copper area in open box free air condition (one channel on).....	36
Figure 46: PowerSSO-16 thermal impedance junction ambient single pulse (one channel on).....	36
Figure 47: Thermal fitting model of a double-channel HSD in PowerSSO-16.....	37
Figure 48: PowerSSO-16 package dimensions.....	38
Figure 49: PowerSSO-16 reel 13".....	40
Figure 50: PowerSSO-16 carrier tape.....	41
Figure 51: PowerSSO-16 schematic drawing of leader and trailer tape.....	41
Figure 52: PowerSSO-16 marking information.....	42

1 Block diagram and pin description

Figure 1: Block diagram

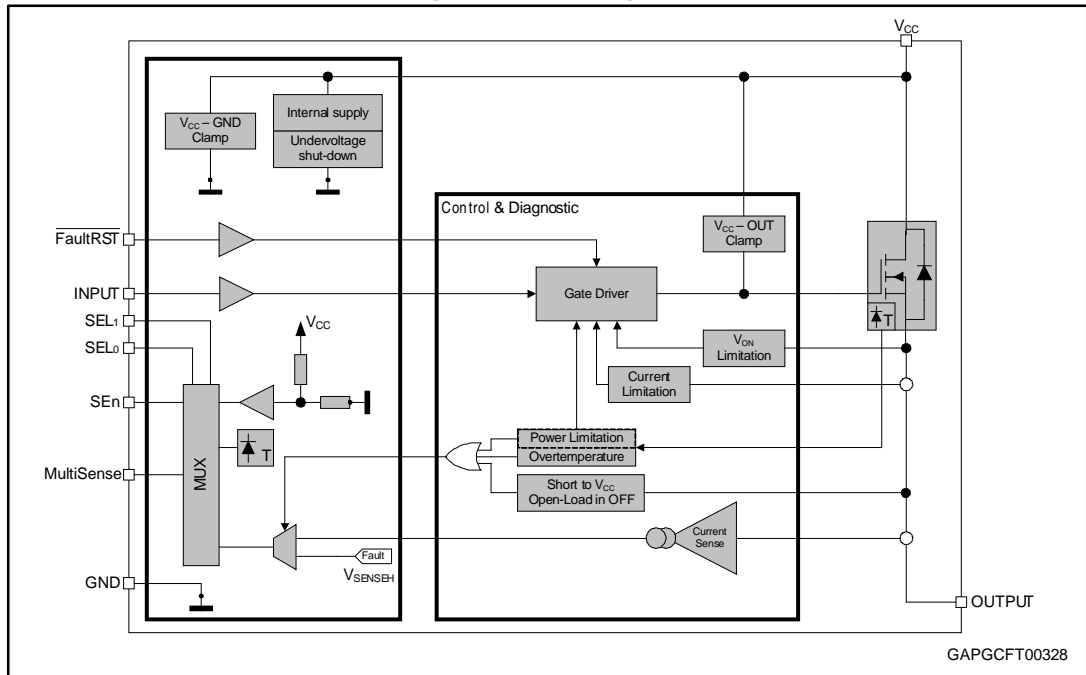
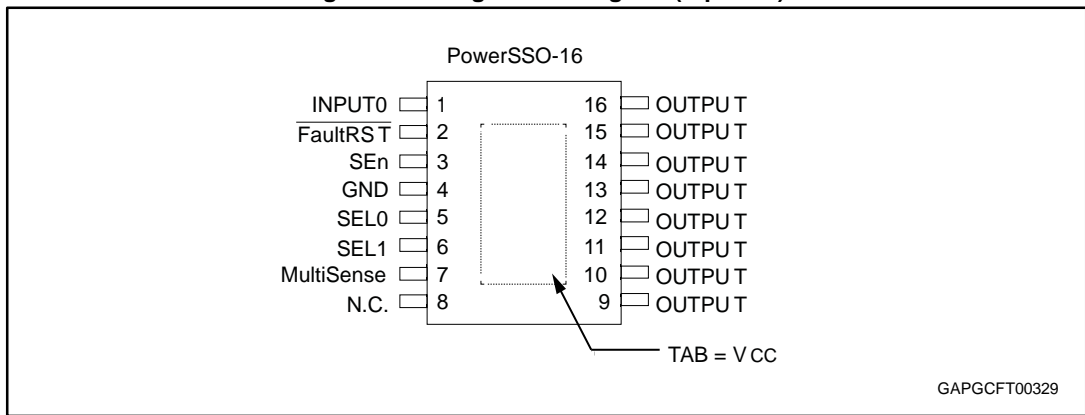

Table 1: Pin functions

Name	Function
V _{CC}	Battery connection.
OUTPUT	Power outputs. All the pins must be connected together.
GND	Ground connection. Must be reverse battery protected by an external diode / resistor network.
INPUT	Voltage controlled input pin with hysteresis, compatible with 3 V and 5 V CMOS outputs. It controls output switch state.
MultiSense	Multiplexed analog sense output pin; it delivers a current proportional to the selected diagnostic: load current, supply voltage or chip temperature.
SEn	Active high compatible with 3 V and 5 V CMOS outputs pin; it enables the MultiSense diagnostic pin.
SEL _{0,1}	Active high compatible with 3 V and 5 V CMOS outputs pin; they address the MultiSense multiplexer.
FaultRST	Active low compatible with 3 V and 5 V CMOS outputs pin; it unlatches the output in case of fault; If kept low, sets the outputs in auto-restart. mode

Figure 2: Configuration diagram (top view)



Pins 9, 10, 11 and 12 are internally connected; Pins 13, 14, 15 and 16 are internally connected; All output pins must be connected together on PCB.

Table 2: Suggested connections for unused and not connected pins

Connection / pin	MultiSense	N.C.	Output	Input	SEn, SELx, FaultRST
Floating	Not allowed	X ⁽¹⁾	X	X	X
To ground	Through 1 kΩ resistor	X	Not allowed	Through 15 kΩ resistor	Through 15 kΩ resistor

Notes:

⁽¹⁾X: do not care.

2 Electrical specification

Figure 3: Current and voltage conventions

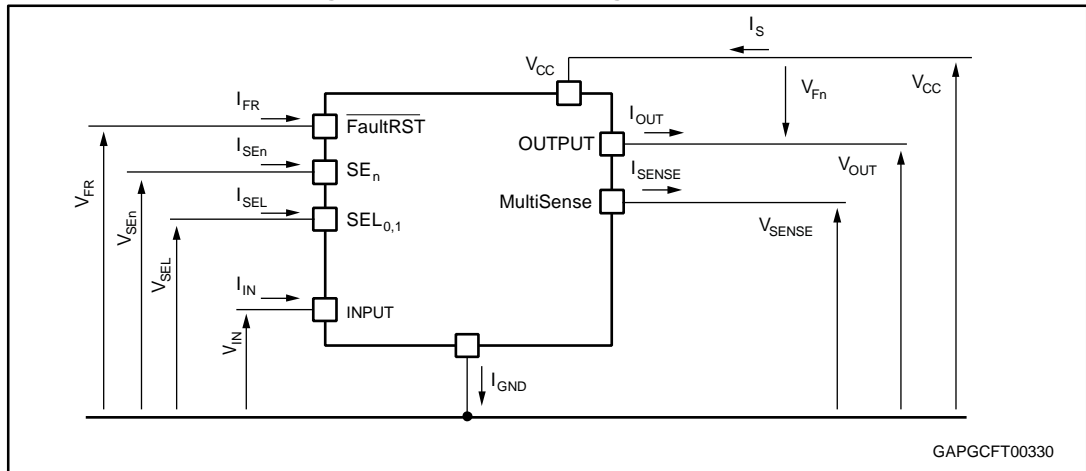

$V_{Fn} = V_{OUTn} - V_{CC}$ during reverse battery condition.

2.1 Absolute maximum ratings

Stressing the device above the rating listed in [Table 3: "Absolute maximum ratings"](#) may cause permanent damage to the device. These are stress ratings only and operation of the device at these or any other conditions above those indicated in the operating sections of this specification is not implied. Exposure to the conditions in table below for extended periods may affect device reliability.

Table 3: Absolute maximum ratings

Symbol	Parameter	Value	Unit
V_{CC}	DC supply voltage	38	V
$-V_{CC}$	Reverse DC supply voltage	0.3	
V_{CCPK}	Maximum transient supply voltage (ISO 16750-2:2010 Test B clamped to 40 V; $R_L = 4 \Omega$)	40	V
V_{CCJS}	Maximum jump start voltage for single pulse short circuit protection	28	V
$-I_{GND}$	DC reverse ground pin current	200	mA
I_{OUT}	OUTPUT DC output current	Internally limited	A
$-I_{OUT}$	Reverse DC output current	22	
I_{IN}	INPUT DC input current	-1 to 10	mA
I_{SEn}	SE _n DC input current		
I_{SEL}	SEL _{0,1} DC input current		
I_{FR}	FaultRST DC input current		

Symbol	Parameter	Value	Unit
V _{FR}	FaultRST DC input voltage	7.5	V
I _{SENSE}	MultiSense pin DC output current (V _{GND} = V _{CC} and V _{SENSE} < 0 V)	10	mA
	MultiSense pin DC output current in reverse (V _{CC} < 0 V)	-20	
-V _{SENSE}	MultiSense pin DC inverse voltage	3	V
E _{MAX}	Maximum switching energy (single pulse) (T _{DEMAG} = 0.4 ms; T _{jstart} = 150 °C)	88	mJ
V _{ESD}	Electrostatic discharge (JEDEC 22A-114F)	4000	V
	• INPUT	2000	V
	• MultiSense	4000	V
	• SEn, SEL _{0,1} , FaultRST	4000	V
	• OUTPUT	4000	V
	• V _{CC}	4000	V
V _{ESD}	Charge device model (CDM-AEC-Q100-011)	750	V
T _j	Junction operating temperature	-40 to 150	°C
T _{stg}	Storage temperature	-55 to 150	

2.2 Thermal data

Table 4: Thermal data

Symbol	Parameter	Typ. value	Unit
R _{thj-board}	Thermal resistance junction-board (JEDEC JESD 51-5 / 51-8) ⁽¹⁾	4.6	°C/W
R _{thj-amb}	Thermal resistance junction-ambient (JEDEC JESD 51-5) ⁽²⁾	55	
R _{thj-amb}	Thermal resistance junction-ambient (JEDEC JESD 51-7) ⁽¹⁾	21.5	

Notes:

⁽¹⁾Device mounted on four-layers 2s2p PCB

⁽²⁾Device mounted on two-layers 2s0p PCB with 2 cm² heatsink copper trace

2.3 Main electrical characteristics

7 V < V_{CC} < 18 V; -40°C < T_j < 150°C, unless otherwise specified.

All typical values refer to V_{CC} = 13 V; T_j = 25°C, unless otherwise specified.

Table 5: Power section

Symbol	Parameter	Test conditions	Min.	Typ.	Max.	Unit
V _{CC}	Operating supply voltage		4	13	28	V
V _{USD}	Undervoltage shutdown				4	V
V _{USDReset}	Undervoltage shutdown reset				5	V
V _{USDhyst}	Undervoltage shutdown hysteresis			0.3		V

Symbol	Parameter	Test conditions	Min.	Typ.	Max.	Unit
R _{ON}	On-state resistance	I _{OUT} = 5 A; T _j = 25°C		16		mΩ
		I _{OUT} = 5 A; T _j = 150°C			32	
		I _{OUT} = 5 A; V _{CC} = 4 V; T _j = 25°C			24	
V _{clamp}	Clamp voltage	I _S = 20 mA; 25°C < T _j < 150°C	41	46	52	V
		I _S = 20 mA; T _j = -40°C	38			V
I _{STBY}	Supply current in standby at V _{CC} = 13 V ⁽¹⁾	V _{CC} = 13 V; V _{IN} = V _{OUT} = V _{FR} = V _{SEN} = 0 V; V _{SELO,1} = 0 V; T _j = 25°C			0.5	μA
		V _{CC} = 13 V; V _{IN} = V _{OUT} = V _{FR} = V _{SEN} = 0 V; V _{SELO,1} = 0 V; T _j = 85°C ⁽²⁾			0.5	
		V _{CC} = 13 V; V _{IN} = V _{OUT} = V _{FR} = V _{SEN} = 0 V; V _{SELO,1} = 0 V; T _j = 125°C			3	
t _{d_STBY}	Standby mode blanking time	V _{CC} = 13 V; V _{SEN} = 5 V to 0 V; V _{IN} = V _{OUT} = V _{FR} = V _{SELO,1} = 0 V	60	300	550	μs
I _{S(ON)}	Supply current	V _{CC} = 13 V; V _{SEN} = V _{FR} = V _{SELO,1} = 0 V; V _{IN} = 5 V; I _{OUT} = 0 A		3	5	mA
I _{GND(ON)}	Control stage current consumption in ON-state. All channels active.	V _{CC} = 13 V; V _{SEN} = 5 V; V _{FR} = V _{SELO,1} = 0 V; V _{IN} = 5 V; I _{OUT} = 3 A			6	mA
I _{L(off)}	Off-state output current at V _{CC} = 13 V	V _{IN} = V _{OUT} = 0 V; V _{CC} = 13 V; T _j = 25°C	0	0.01	0.5	μA
		V _{IN} = V _{OUT} = 0 V; V _{CC} = 13 V; T _j = 125°C	0		3	
V _F	Output - V _{CC} diode voltage	I _{OUT} = -5 A; T _j = 150°C			0.7	V

Notes:

(1) PowerMOS leakage included.

(2) Parameter specified by design; not subject to production test.

Table 6: Switching

V _{CC} = 13 V; -40°C < T _j < 150°C, unless otherwise specified						
Symbol	Parameter	Test conditions	Min.	Typ.	Max.	Unit
t _{d(on)} ⁽¹⁾	Turn-on delay time at T _j = 25 °C	R _L = 2.6 Ω	10	30	120	μs
t _{d(off)} ⁽¹⁾	Turn-off delay time at T _j = 25 °C		10	50	100	
(dV _{OUT} /dt) _{on} ⁽¹⁾	Turn-on voltage slope at T _j = 25 °C	R _L = 2.6 Ω	0.1	0.31	0.7	V/μs
(dV _{OUT} /dt) _{off} ⁽¹⁾	Turn-off voltage slope at T _j = 25 °C		0.1	0.31	0.7	
W _{ON}	Switching energy losses at turn-on (t _{won})	R _L = 2.6 Ω	—	0.7	0.94 ⁽²⁾	mJ
W _{OFF}	Switching energy losses at turn-off (t _{woff})	R _L = 2.6 Ω	—	0.7	0.91 ⁽²⁾	mJ
t _{SKEW} ⁽¹⁾	Differential Pulse skew (t _{PHL} - t _{PLH})	R _L = 2.6 Ω	-40	10	60	μs

Notes:(1) See [Figure 6: "Switching time and Pulse skew"](#).

(2) Parameter guaranteed by design and characterization; not subject to production test.

Table 7: Logic inputs

7 V < V _{CC} < 28 V; -40°C < T _j < 150°C						
Symbol	Parameter	Test conditions	Min.	Typ.	Max.	Unit
INPUT characteristics						
V _{IL}	Input low level voltage				0.9	V
I _{IL}	Low level input current	V _{IN} = 0.9 V	1			μA
V _{IH}	Input high level voltage		2.1			V
I _{IH}	High level input current	V _{IN} = 2.1 V			10	μA
V _{I(hyst)}	Input hysteresis voltage		0.2			V
V _{ICL}	Input clamp voltage	I _{IN} = 1 mA	5.3		7.2	V
		I _{IN} = -1 mA		-0.7		
FaultRST characteristics						
V _{FRL}	Input low level voltage				0.9	V
I _{FRL}	Low level input current	V _{IN} = 0.9 V	1			μA
V _{FRH}	Input high level voltage		2.1			V
I _{FRH}	High level input current	V _{IN} = 2.1 V			10	μA
V _{FR(hyst)}	Input hysteresis voltage		0.2			V
V _{FRCL}	Input clamp voltage	I _{IN} = 1 mA	5.3		7.5	V
		I _{IN} = -1 mA		-0.7		
SEL_{0,1} characteristics (7 V < V_{CC} < 18 V)						
V _{SELL}	Input low level voltage				0.9	V
I _{SELL}	Low level input current	V _{IN} = 0.9 V	1			μA
V _{SELH}	Input high level voltage		2.1			V
I _{SELH}	High level input current	V _{IN} = 2.1 V			10	μA
V _{SEL(hyst)}	Input hysteresis voltage		0.2			V
V _{SELCL}	Input clamp voltage	I _{IN} = 1 mA	5.3		7.2	V
		I _{IN} = -1 mA		-0.7		
SEn characteristics (7 V < V_{CC} < 18 V)						
V _{SEnL}	Input low level voltage				0.9	V
I _{SEnL}	Low level input current	V _{IN} = 0.9 V	1			μA
V _{SEnH}	Input high level voltage		2.1			V
I _{SEnH}	High level input current	V _{IN} = 2.1 V			10	μA
V _{SEn(hyst)}	Input hysteresis voltage		0.2			V
V _{SEnCL}	Input clamp voltage	I _{IN} = 1 mA	5.3		7.2	V
		I _{IN} = -1 mA		-0.7		

Table 8: Protections

7 V < V _{CC} < 18 V; -40°C < T _j < 150°C						
Symbol	Parameter	Test conditions	Min.	Typ.	Max.	Unit
I _{LIMH}	DC short circuit current	V _{CC} = 13 V	55	77	110	A
		4 V < V _{CC} < 18 V ⁽¹⁾				
I _{LIML}	Short circuit current during thermal cycling	V _{CC} = 13 V; T _R < T _j < T _{TSD}		32		
T _{TSD}	Shutdown temperature		150	175	200	°C
T _R	Reset temperature ⁽¹⁾		T _{RS} + 1	T _{RS} + 7		
T _{RS}	Thermal reset of fault diagnostic indication	V _{FR} = 0 V; V _{SEN} = 5 V	135			
T _{HYST}	Thermal hysteresis (T _{TSD} - T _R) ⁽¹⁾			7		
ΔT _{J_SD}	Dynamic temperature	T _j = -40°C; V _{CC} = 13 V		60		K
t _{LATCH_RST}	Fault reset time for output unlatch ⁽¹⁾	V _{FR} = 5 V to 0 V; V _{SEN} = 5 V; V _{IN} = 5 V; V _{SELO} = 0 V; V _{SEL1} = 0 V	3	10	20	μs
V _{DEMAG}	Turn-off output voltage clamp	I _{OUT} = 2 A; L = 6 mH; T _j = -40°C	V _{CC} - 38			V
		I _{OUT} = 2 A; L = 6 mH; T _j = 25°C to 150°C	V _{CC} - 41	V _{CC} - 46	V _{CC} - 52	V
V _{ON}	Output voltage droplimitation	I _{OUT} = 0.6 A		20		mV

Notes:

⁽¹⁾Parameter guaranteed by design and characterization; not subject to production test.

Table 9: MultiSense

7 V < V _{CC} < 18 V; -40°C < T _j < 150°C						
Symbol	Parameter	Test conditions	Min.	Typ.	Max.	Unit
V _{SENSE_CL}	MultiSense clamp voltage	V _{SEN} = 0 V; I _{SENSE} = 1 mA	-17		-12	V
		V _{SEN} = 0 V; I _{SENSE} = -1 mA		7		
CurrentSense characteristics						
K ₀	I _{OUT} /I _{SENSE}	I _{OUT} = 0.6 A; V _{SENSE} = 0.5 V; V _{SEN} = 5 V	2370	3900	5540	
dK ₀ /K ₀ ⁽¹⁾⁽²⁾	Current sense ratio drift	I _{OUT} = 0.6 A; V _{SENSE} = 0.5 V; V _{SEN} = 5 V	-20		20	%
K ₁	I _{OUT} /I _{SENSE}	I _{OUT} = 1 A; V _{SENSE} = 4 V; V _{SEN} = 5 V	2560	3640	4760	
dK ₁ /K ₁ ⁽¹⁾⁽²⁾	Current sense ratio drift	I _{OUT} = 1 A; V _{SENSE} = 4 V; V _{SEN} = 5 V	-15		15	%
K ₂	I _{OUT} /I _{SENSE}	I _{OUT} = 4 A; V _{SENSE} = 4 V; V _{SEN} = 5 V	2770	3440	4170	

7 V < V _{CC} < 18 V; -40°C < T _j < 150°C						
Symbol	Parameter	Test conditions	Min.	Typ.	Max.	Unit
dK ₂ /K ₂ ⁽¹⁾⁽²⁾	Current sense ratio drift	I _{OUT} = 4 A; V _{SENSE} = 4 V; V _{SEn} = 5 V	-10		10	%
K ₃	I _{OUT} /I _{SENSE}	I _{OUT} = 12 A; V _{SENSE} = 4 V; V _{SEn} = 5 V	3080	3420	3760	
dK ₃ /K ₃ ⁽¹⁾⁽²⁾	Current sense ratio drift	I _{OUT} = 12 A; V _{SENSE} = 4 V; V _{SEn} = 5 V	-5		5	%
I _{SENSE0}	MultiSense leakage current	MultiSense disabled: V _{SEn} = 0 V	0		0.5	μA
		MultiSense disabled: -1 V < V _{SENSE} < 5 V ⁽¹⁾	-0.5		0.5	
		MultiSense enabled: V _{SEn} = 5 V; Channel ON; I _{OUT} = 0 A; Diagnostic selected; V _{IN} = 5 V; V _{SEL0} = 0 V; V _{SEL1} = 0 V; I _{OUT} = 0 A	0		2	
		MultiSense enabled: V _{SEn} = 5 V; Channel OFF; Diagnostic selected: V _{IN} = 0 V; V _{SEL0} = 0 V; V _{SEL1} = 0 V	0		2	
V _{OUT_MSD} ⁽¹⁾	Output Voltage for MultiSense shutdown	V _{IN} = 5 V; V _{SEn} = 5 V; V _{SEL0} = 0 V; V _{SEL1} = 0 V; R _{SENSE} = 2.7 kΩ; I _{OUT} = 5 A		5		V
V _{SENSE_SAT}	Multisense saturation voltage	V _{CC} = 7 V; R _{SENSE} = 2.7 kΩ; V _{SEn} = 5 V; V _{IN} = 5 V; V _{SEL0} = 0 V; V _{SEL1} = 0 V; I _{OUT} = 12 A; T _j = 150°C	5			V
I _{SENSE_SAT} ⁽¹⁾	CS saturation current	V _{CC} = 7 V; V _{SENSE} = 4 V; V _{IN} = 5 V; V _{SEn} = 5 V; V _{SEL0} = 0 V; V _{SEL1} = 0 V; T _j = 150°C	4			mA
I _{OUT_SAT} ⁽¹⁾	Output saturation current	V _{CC} = 7 V; V _{SENSE} = 4 V; V _{IN} = 5 V; V _{SEn} = 5 V; V _{SEL0} = 0 V; V _{SEL1} = 0 V; T _j = 150°C	15			A
OFF-state diagnostic						
V _{OL}	OFF-state open-load voltage detection threshold	V _{IN} = 0 V; V _{SEn} = 5 V; V _{SEL0} = 0 V; V _{SEL1} = 0 V	2	3	4	V
I _{L(off2)}	OFF-state output sink current	V _{IN} = 0 V; V _{OUT} = V _{OL} ; T _j = -40°C to 125°C	-100		-15	μA
t _{DSTKON}	OFF-state diagnostic delay time from falling edge of INPUT (see Figure 9: "DSTKON")	V _{IN} = 5 V to 0 V; V _{SEn} = 5 V; V _{SEL0} = 0 V; V _{SEL1} = 0 V; I _{OUT} = 0 A; V _{OUT} = 4 V	100	350	700	μs
t _{D_OL_V}	Settling time for valid OFF-state open-load diagnostic indication from rising edge of SE _n	V _{IN} = 0 V; V _{FR} = 0 V; V _{SEL0} = 0 V; V _{SEL1} = 0 V; V _{OUT} = 4 V; V _{SEn} = 0 V to 5 V			60	μs

7 V < V _{CC} < 18 V; -40°C < T _j < 150°C						
Symbol	Parameter	Test conditions	Min.	Typ.	Max.	Unit
t _{D_VOL}	OFF-state diagnostic delay time from rising edge of V _{OUT}	V _{IN} = 0 V; V _{SEn} = 5 V; V _{SELO} = 0 V; V _{SEL1} = 0 V; V _{OUT} = 0 V to 4 V		5	30	μs
Chip temperature analog feedback						
V _{SENSE_TC}	MultiSense output voltage proportional to chip temperature	V _{SEn} = 5 V; V _{SELO} = 0 V; V _{SEL1} = 5 V; V _{IN} = 0 V; R _{SENSE} = 1 kΩ; T _j = -40°C	2.325	2.41	2.495	V
		V _{SEn} = 5 V; V _{SELO} = 0 V; V _{SEL1} = 5 V; V _{IN} = 0 V; R _{SENSE} = 1 kΩ; T _j = 25°C	1.985	2.07	2.155	V
		V _{SEn} = 5 V; V _{SELO} = 0 V; V _{SEL1} = 5 V; V _{IN} = 0 V; R _{SENSE} = 1 kΩ; T _j = 125°C	1.435	1.52	1.605	V
dV _{SENSE_TC} /dT	Temperature coefficient	T _j = -40°C to 150°C		-5.5		mV/K
Transfer function		V _{SENSE_TC} (T) = V _{SENSE_TC} (T ₀) + dV _{SENSE_TC} / dT * (T - T ₀)				
V_{CC} supply voltage analog feedback						
V _{SENSE_VCC}	MultiSense output voltage proportional to V _{CC} supply voltage	V _{CC} = 13 V; V _{SEn} = 5 V; V _{SELO} = 5 V; V _{SEL1} = 5 V; V _{IN} = 0 V; R _{SENSE} = 1 kΩ	3.16	3.23	3.3	V
Transfer function ⁽³⁾		V _{SENSE_VCC} = V _{CC} / 4				
Fault diagnostic feedback (see Table 10: "Truth table")						
V _{SENSEH}	MultiSense output voltage in fault condition	V _{CC} = 13 V; V _{IN} = 0 V; V _{SEn} = 5 V; V _{SELO} = 0 V; V _{SEL1} = 0 V; I _{OUT} = 0 A; V _{OUT} = 4 V; R _{SENSE} = 1 kΩ;	5		6.6	V
I _{SENSEH}	MultiSense output current in fault condition	V _{CC} = 13 V; V _{SENSE} = 5 V	7	20	30	mA
MultiSense timings (current sense mode - see Figure 7: "MultiSense timings (current sense mode)")⁽⁴⁾						
t _{DSENSE1H}	Current sense settling time from rising edge of SEn	V _{IN} = 5 V; V _{SEn} = 0 V to 5 V; R _{SENSE} = 1 kΩ; R _L = 2.6 Ω			60	μs
t _{DSENSE1L}	Current sense disable delay time from falling edge of SEn	V _{IN} = 5 V; V _{SEn} = 5 V to 0 V; R _{SENSE} = 1 kΩ; R _L = 2.6 Ω		5	20	μs
t _{DSENSE2H}	Current sense settling time from rising edge of INPUT	V _{IN} = 0 V to 5 V; V _{SEn} = 5 V; R _{SENSE} = 1 kΩ; R _L = 2.6 Ω		100	250	μs
Δt _{DSENSE2H}	Current sense settling time from rising edge of I _{OUT} (dynamic response to a step change of I _{OUT})	V _{IN} = 5 V; V _{SEn} = 5 V; R _{SENSE} = 1 kΩ; I _{SENSE} = 90 % of I _{SENSEMAX} ; R _L = 2.6 Ω			100	μs

7 V < V _{CC} < 18 V; -40°C < T _j < 150°C						
Symbol	Parameter	Test conditions	Min.	Typ.	Max.	Unit
t _{DSENSE2L}	Current sense turn-off delay time from falling edge of INPUT	V _{IN} = 5 V to 0 V; V _{SEn} = 5 V; R _{SENSE} = 1 kΩ; R _L = 2.6 Ω		50	250	μs
MultiSense timings (chip temperature sense mode - see Figure 8: "Multisense timings (chip temperature and VCC sense mode)")⁽⁴⁾						
t _{DSENSE3H}	V _{SENSE_TC} settling time from rising edge of SEn	V _{SEn} = 0 V to 5 V; V _{SELO} = 0 V; V _{SEL1} = 5 V; R _{SENSE} = 1 kΩ			60	μs
t _{DSENSE3L}	V _{SENSE_TC} disable delay time from falling edge of SEn	V _{SEn} = 5 V to 0 V; V _{SELO} = 0 V; V _{SEL1} = 5 V; R _{SENSE} = 1 kΩ			20	μs
MultiSense timings (V_{CC} voltage sense mode - see Figure 8: "Multisense timings (chip temperature and VCC sense mode)")⁽⁴⁾						
t _{DSENSE4H}	V _{SENSE_VCC} settling time from rising edge of SEn	V _{SEn} = 0 V to 5 V; V _{SELO} = 5 V; V _{SEL1} = 5 V; R _{SENSE} = 1 kΩ			60	μs
t _{DSENSE4L}	V _{SENSE_VCC} disable delay time from falling edge of SEn	V _{SEn} = 5 V to 0 V; V _{SELO} = 5 V; V _{SEL1} = 5 V; R _{SENSE} = 1 kΩ			20	μs
MultiSense timings (Multiplexer transition times)⁽⁴⁾						
t _{D_CStoTC}	MultiSense transition delay from current sense to T _C sense	V _{IN} = 5 V; V _{SEn} = 5 V; V _{SELO} = 0 V; V _{SEL1} = 0 V to 5 V; I _{OUT} = 2.5 A; R _{SENSE} = 1 kΩ			60	μs
t _{D_TcToCS}	MultiSense transition delay from T _C sense to current sense	V _{IN} = 5 V; V _{SEn} = 5 V; V _{SELO} = 0 V; V _{SEL1} = 5 V to 0 V; I _{OUT} = 2.5 A; R _{SENSE} = 1 kΩ			20	μs
t _{D_CStoVCC}	MultiSense transition delay from current sense to V _{CC} sense	V _{IN} = 5 V; V _{SEn} = 5 V; V _{SELO} = 5 V; V _{SEL1} = 0 V to 5 V; I _{OUT} = 2.5 A; R _{SENSE} = 1 kΩ			60	μs
t _{D_VCCtoCS}	MultiSense transition delay from V _{CC} sense to current sense	V _{IN} = 5 V; V _{SEn} = 5 V; V _{SELO} = 5 V; V _{SEL1} = 5 V to 0 V; I _{OUT} = 2.5 A; R _{SENSE} = 1 kΩ			20	μs
t _{D_TcToVCC}	MultiSense transition delay from T _C sense to V _{CC} sense	V _{CC} = 13 V; T _j = 125°C; V _{SEn} = 5 V; V _{SELO} = 0 V to 5 V; V _{SEL1} = 5 V; R _{SENSE} = 1 kΩ			20	μs
t _{D_VCCtoTC}	MultiSense transition delay from V _{CC} sense to T _C sense	V _{CC} = 13 V; T _j = 125°C; V _{SEn} = 5 V; V _{SELO} = 5 V to 0 V; V _{SEL1} = 5 V; R _{SENSE} = 1 kΩ			20	μs

Notes:

- (1)Parameter specified by design; not subject to production test.
- (2)All values refer to V_{CC} = 13 V; T_j = 25°C, unless otherwise specified.
- (3)V_{CC} sensing and T_C are referred to GND potential.
- (4)Transition delay are measured up to +/- 10% of final conditions.

Figure 4: IOUT/ISENSE versus IOU

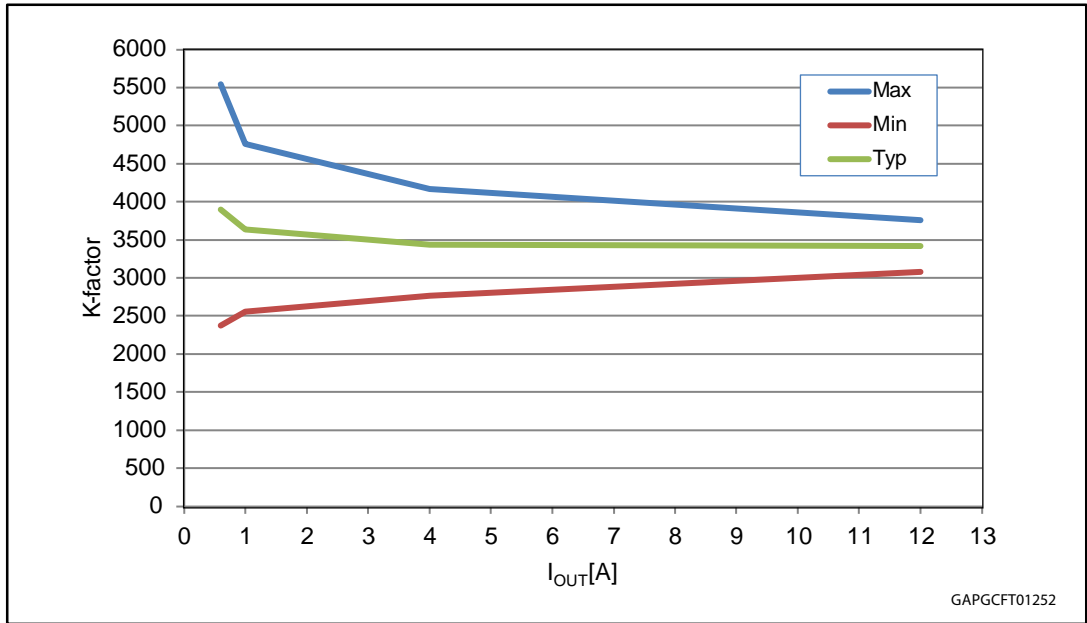

Figure 5: Current sense accuracy versus IOU

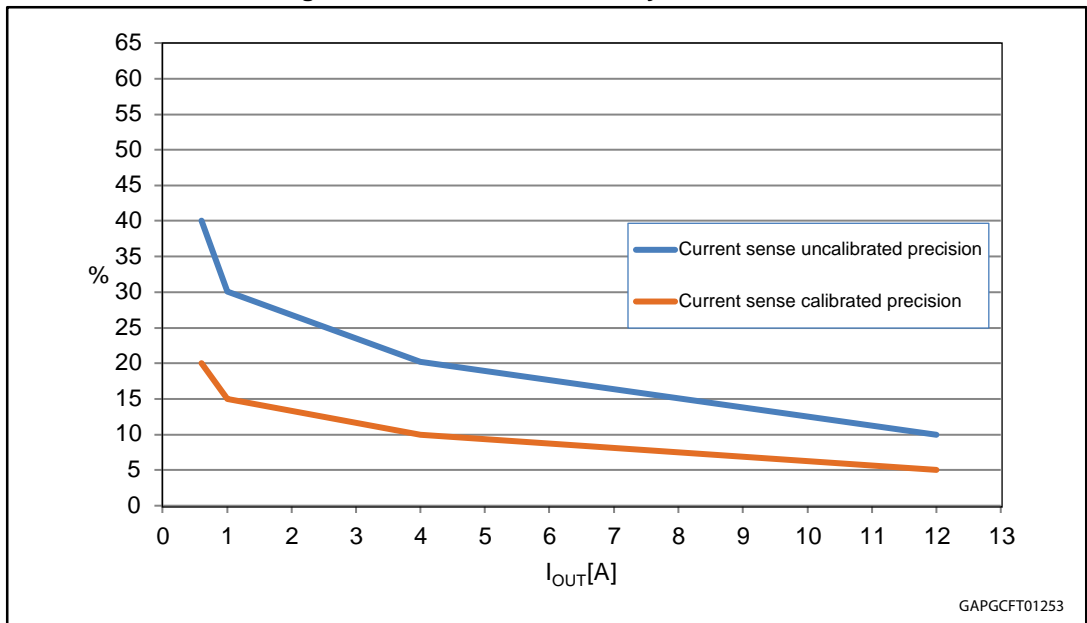

Figure 6: Switching time and Pulse skew

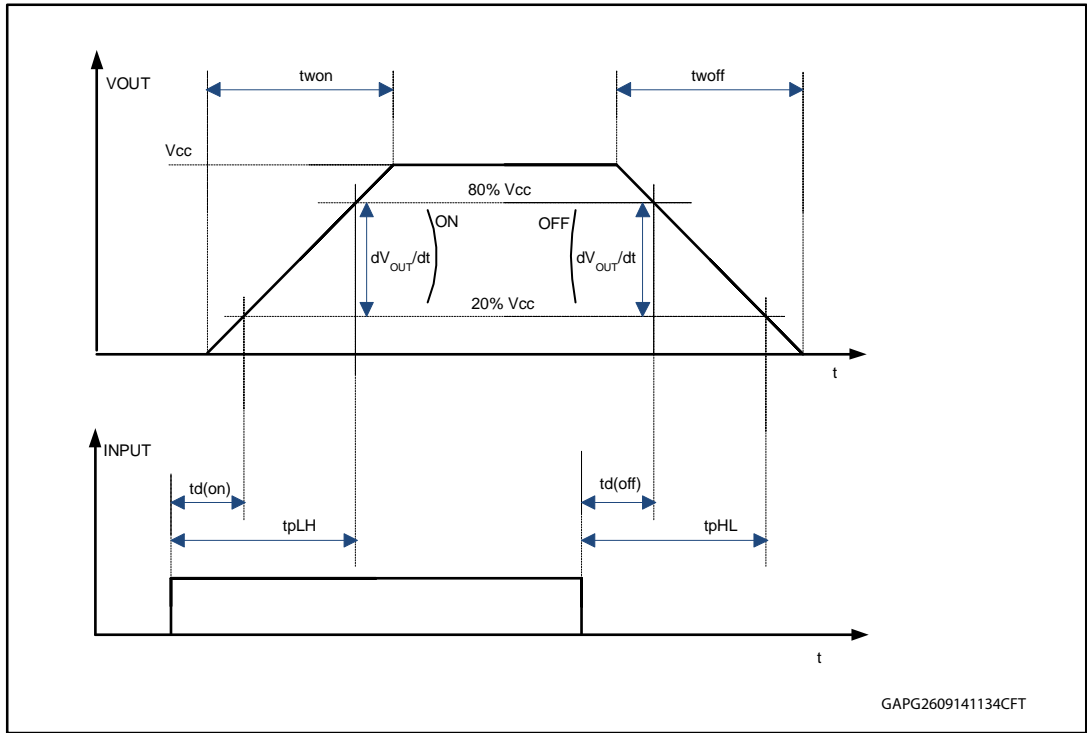

Figure 7: MultiSense timings (current sense mode)

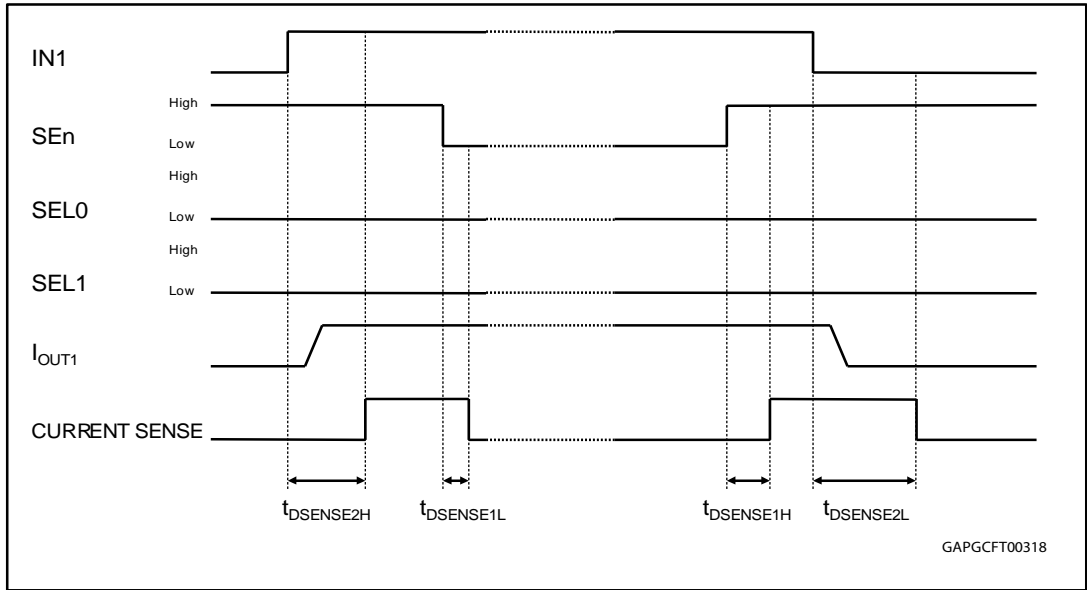

Figure 8: Multisense timings (chip temperature and VCC sense mode)

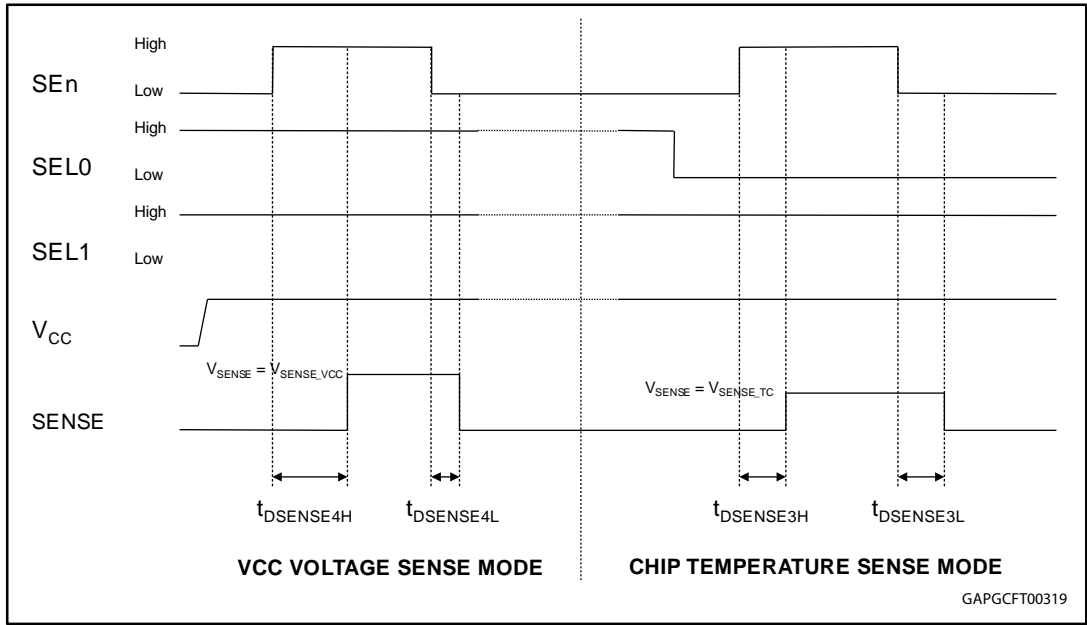

Figure 9: TDSTKON

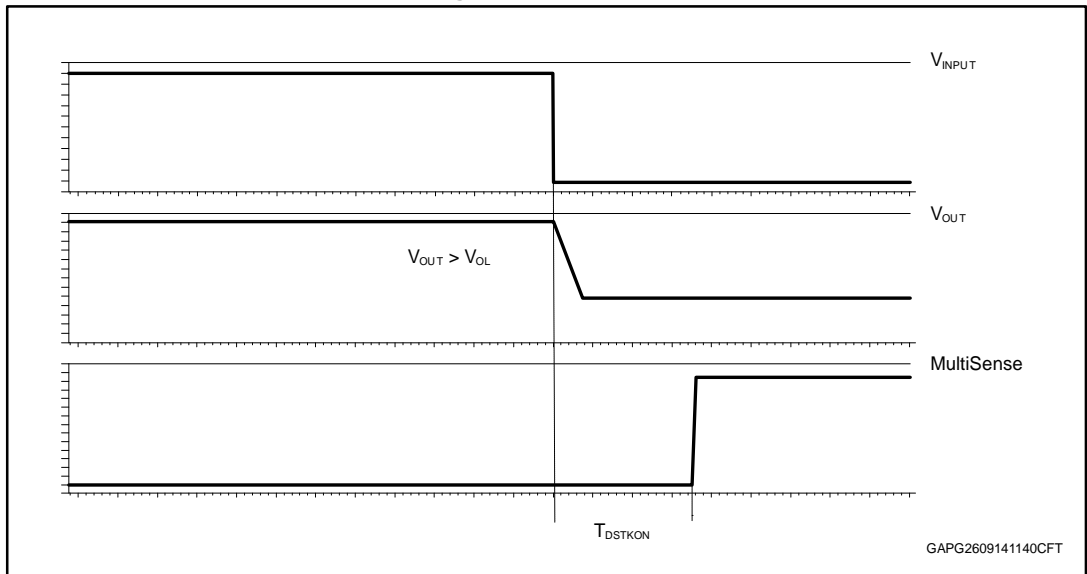

Table 10: Truth table

Mode	Conditions	IN _x	FR	SEn	SEL _x	OUT _x	MultiSense	Comments
Standby	All logic inputs low	L	L	L	L	L	Hi-Z	Low quiescent current consumption
Normal	Nominal load connected; T _j < 150 °C	L	X	See (1)		L	See (1)	
		H	L			H	See (1)	Outputs configured for auto-restart
		H	H			H	See (1)	Outputs configured for Latch-off
Overload	Overload or short to GND causing: T _j > T _{TSD} or ΔT _j > ΔT _{j,SD}	L	X	See (1)		L	See (1)	
		H	L			H	See (1)	Output cycles with temperature hysteresis
		H	H			L	See (1)	Output latches-off
Undervoltage	V _{CC} < V _{USD} (falling)	X	X	X	X	L L	Hi-Z Hi-Z	Re-start when V _{CC} > V _{USD} + V _{USDhyst} (rising)
OFF-state diagnostics	Short to V _{CC}	L	X	See (1)		H	See (1)	
	Open-load	L	X			H	See (1)	External pull-up
Negative output voltage	Inductive loads turn-off	L	X	See (1)		< 0 V	See (1)	

Notes:

(1) Refer to [Table 11: "MultiSense multiplexer addressing"](#)

Table 11: MultiSense multiplexer addressing

SEn	SEL ₁	SEL ₀	MUX channel	MultiSense output			
				Normal mode	Overload	OFF-state diag. (1)	Negative output
L	X	X		Hi-Z			
H	L	L	Output diagnostic	I _{SENSE} = 1/K * I _{OUT}	V _{SENSE} = V _{SENSEH}	V _{SENSE} = V _{SENSEH}	Hi-Z
H	L	H					
H	H	L	T _{CHIP} Sense	V _{SENSE} = V _{SENSE_TC}			
H	H	H	V _{CC} Sense	V _{SENSE} = V _{SENSE_VCC}			

Notes:

(1) In case the output channel corresponding to the selected MUX channel is latched off while the relevant input is low, MultiSense pin delivers feedback according to OFF-State diagnostic. Example 1: FR = 1; IN = 0; OUT = L (latched); MUX channel = channel 0 diagnostic; Mutisense = 0. Example 2: FR = 1; IN = 0; OUT = latched, V_{OUT} > V_{OL}; MUX channel = channel 0 diagnostic; Mutisense = V_{SENSEH}

2.4 Waveforms

Figure 10: Latch functionality - behavior in hard short circuit condition ($T_{AMB} \ll T_{TSD}$)

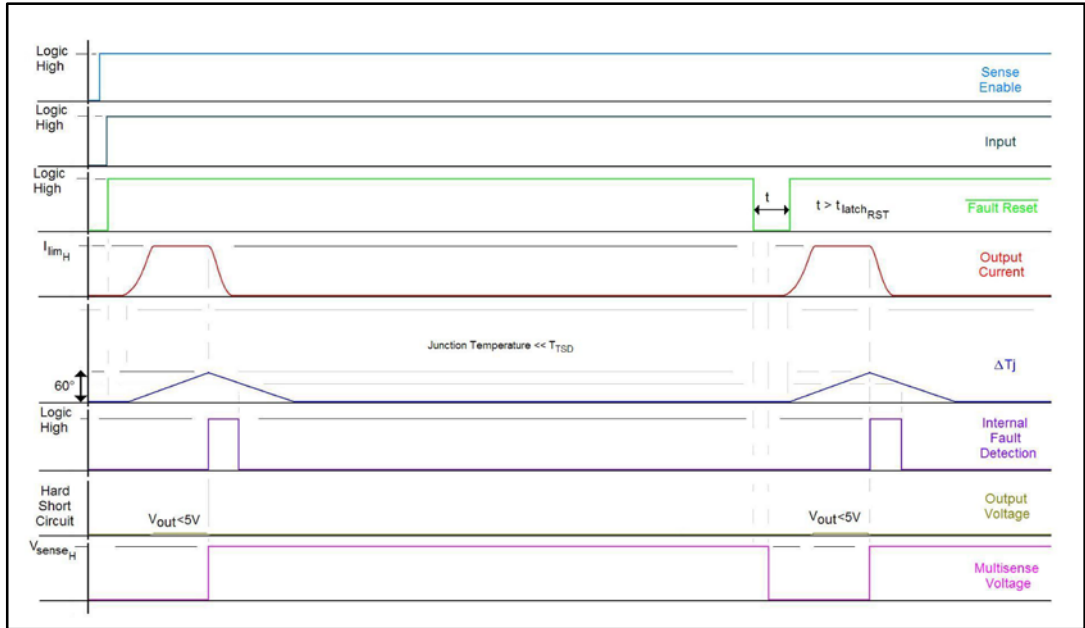

Figure 11: Latch functionality - behavior in hard short circuit condition

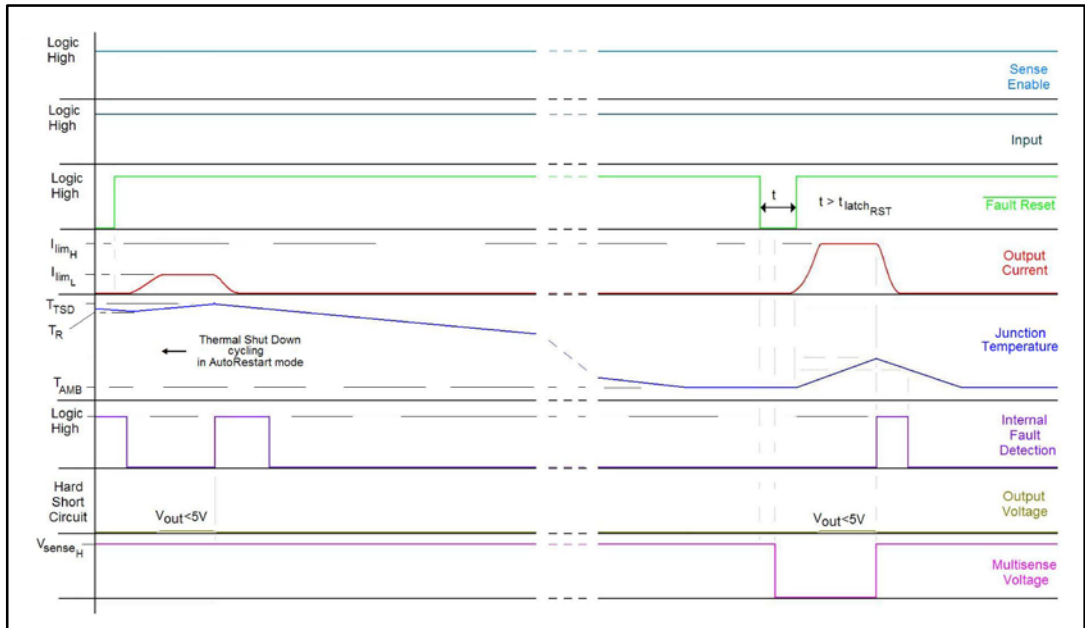

Figure 12: Latch functionality - behavior in hard short circuit condition (autorestart mode + latch off)

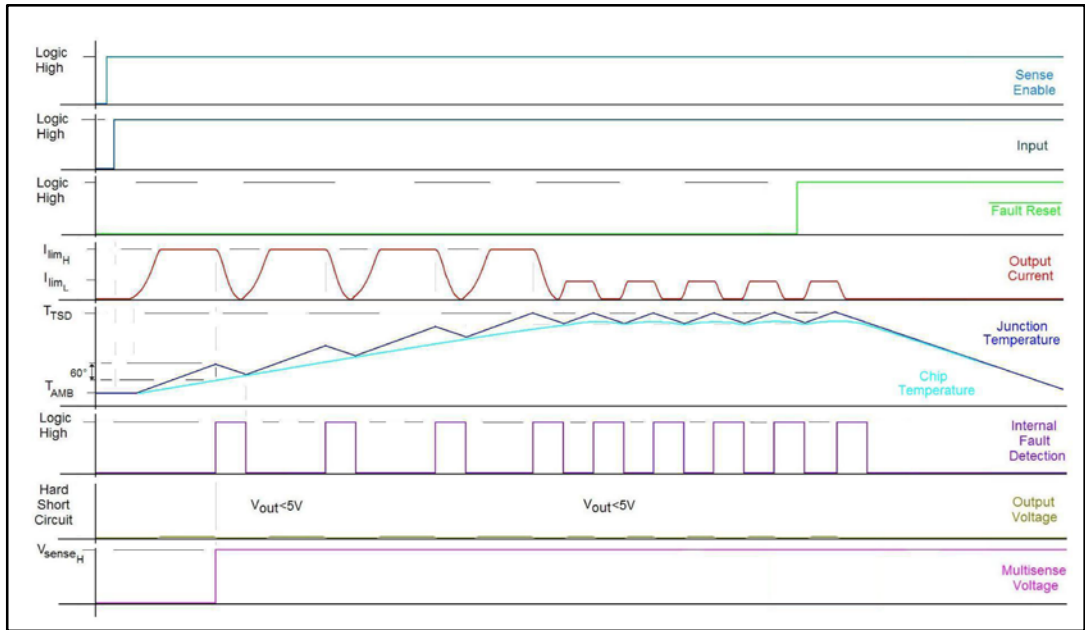

Figure 13: Standby mode activation

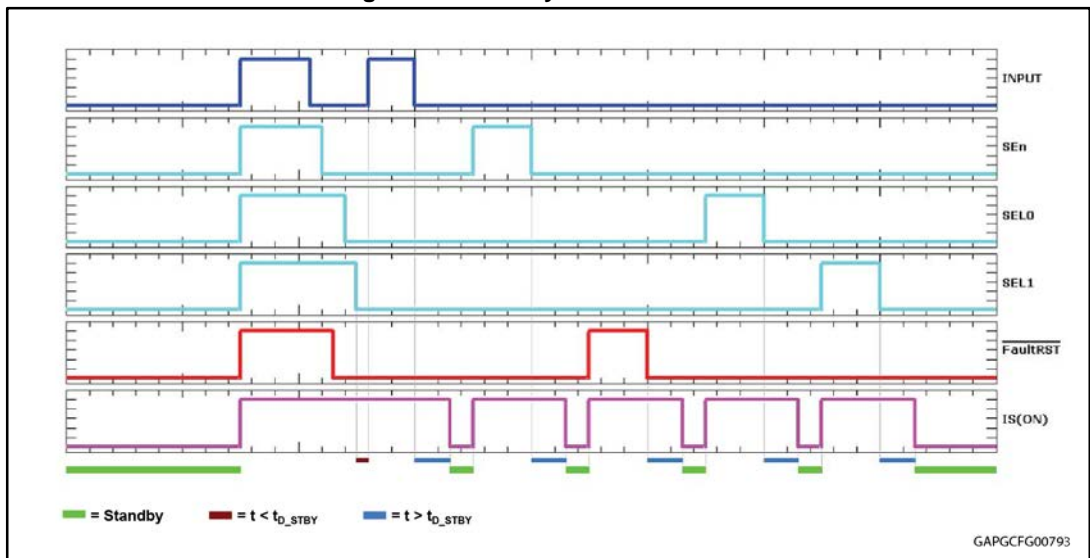
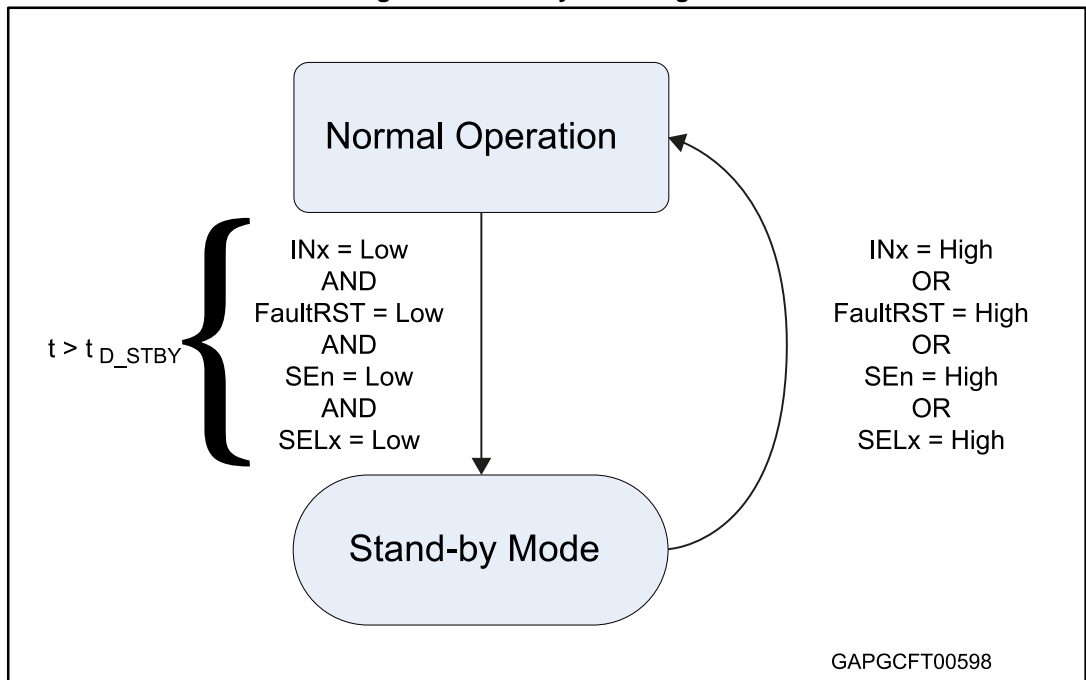

Figure 14: Standby state diagram



2.5 Electrical characteristics curves

Figure 15: OFF-state output current

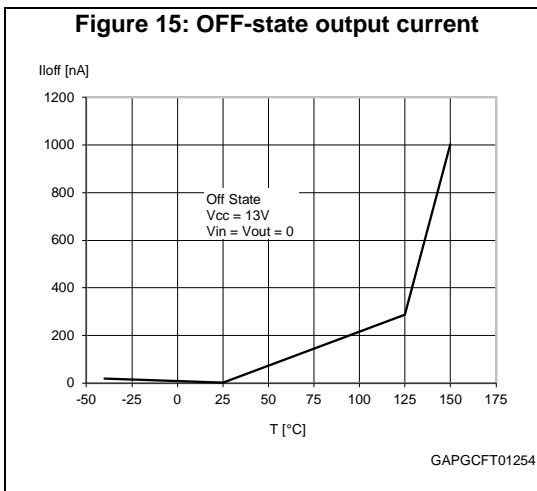
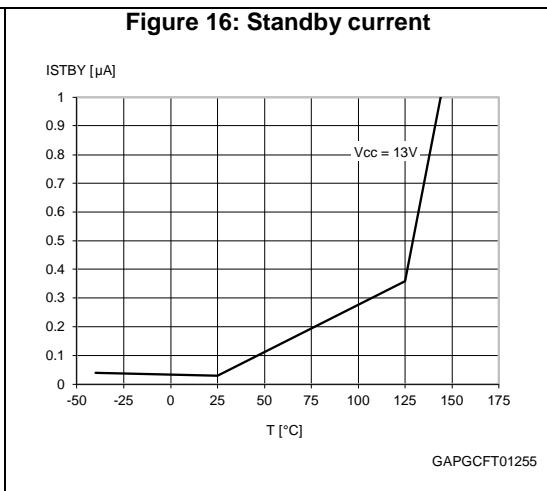

Figure 16: Standby current



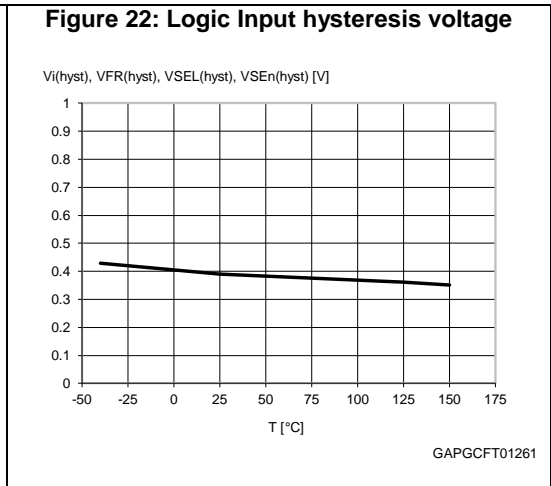
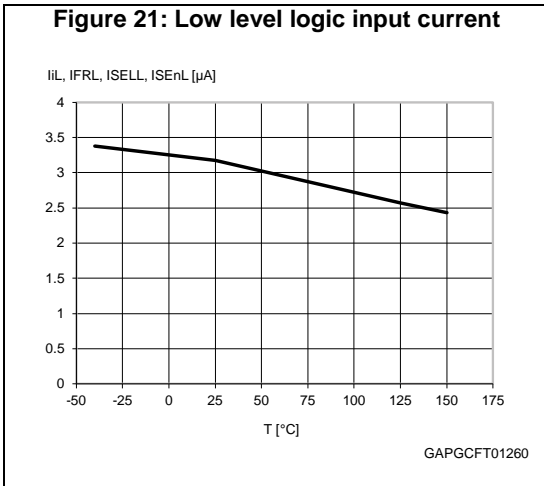
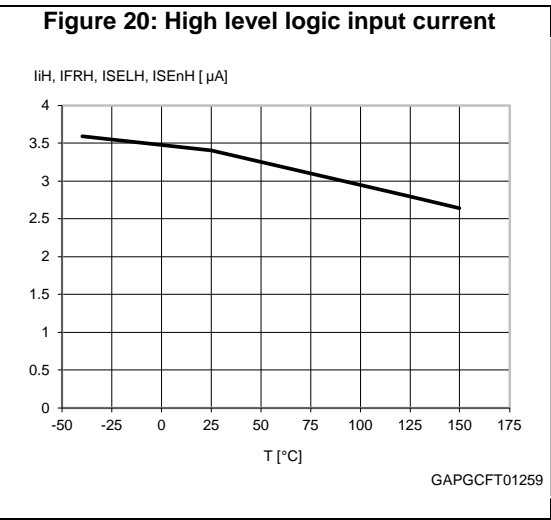
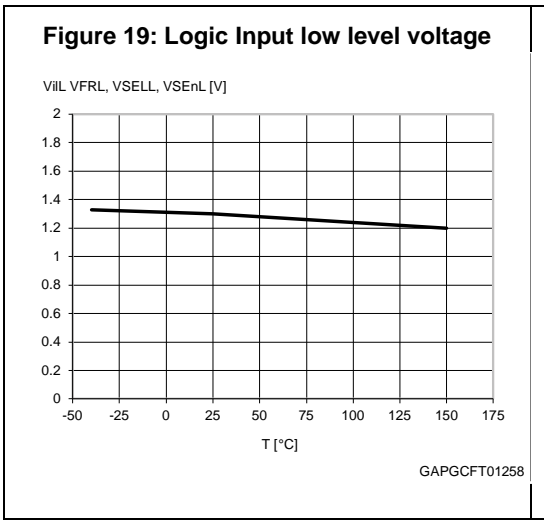
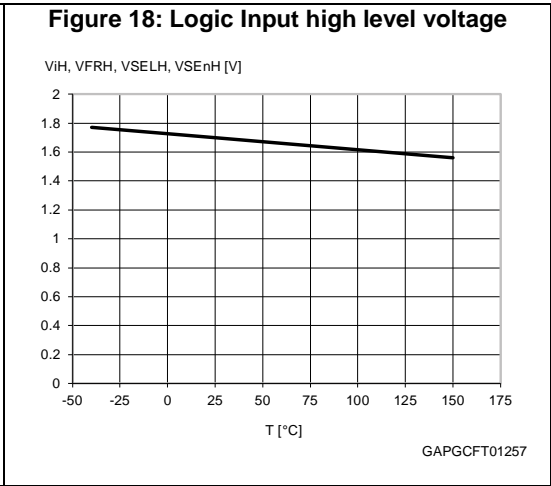
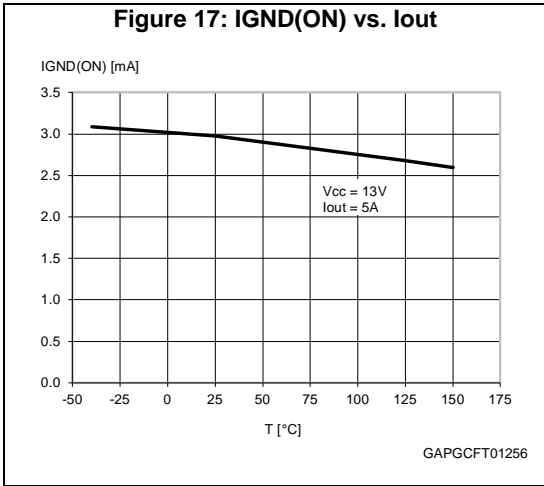
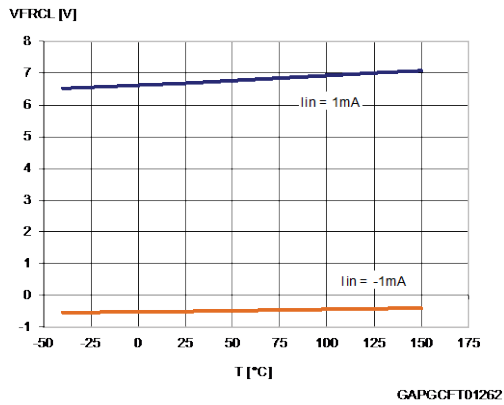
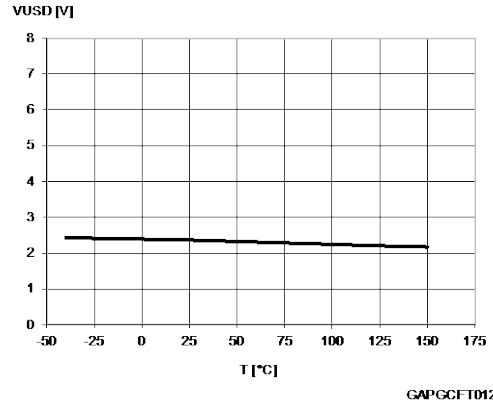

Figure 23: FaultRST Input clamp voltage



GAPGCFT01262

Figure 24: Undervoltage shutdown



GAPGCFT01263

Figure 25: On-state resistance vs. Tcase

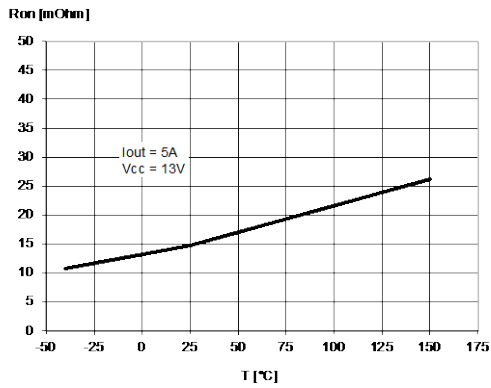

GAPGCFT01264

Figure 26: On-state resistance vs. VCC

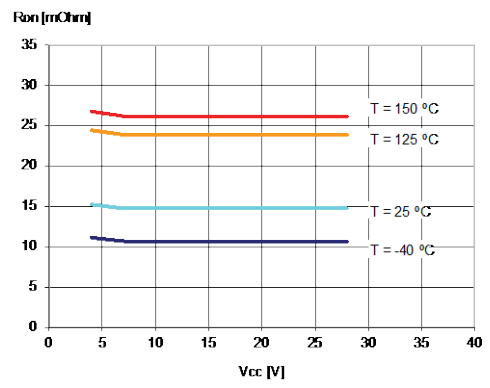

GAPGCFT01265

Figure 27: Turn-on voltage slope

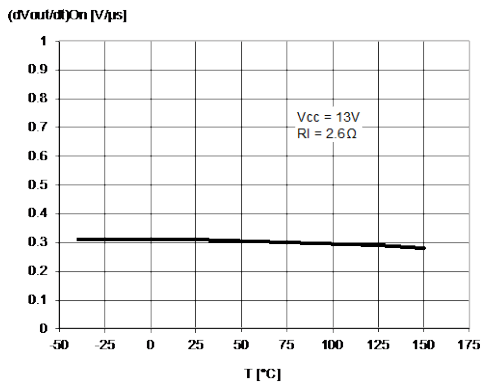

GAPGCFT01266

Figure 28: Turn-off voltage slope

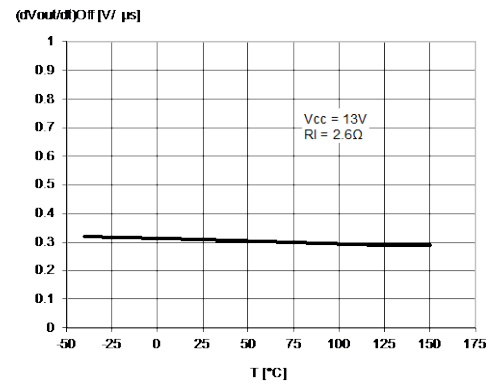

GAPGCFT01267

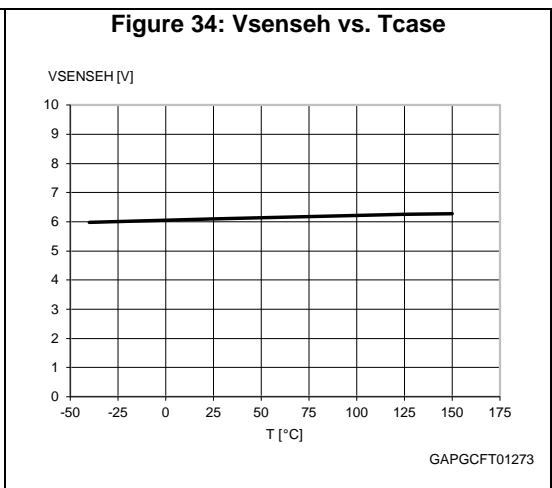
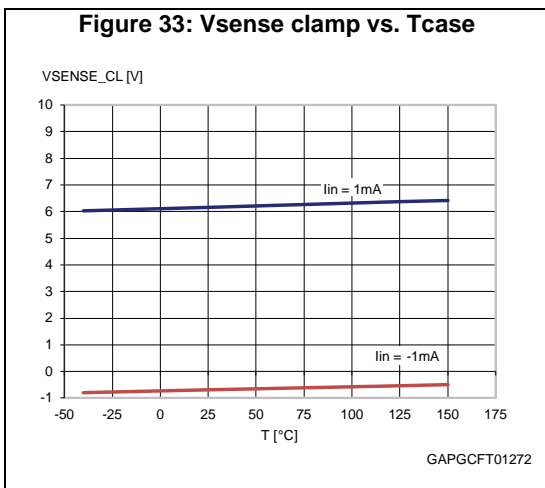
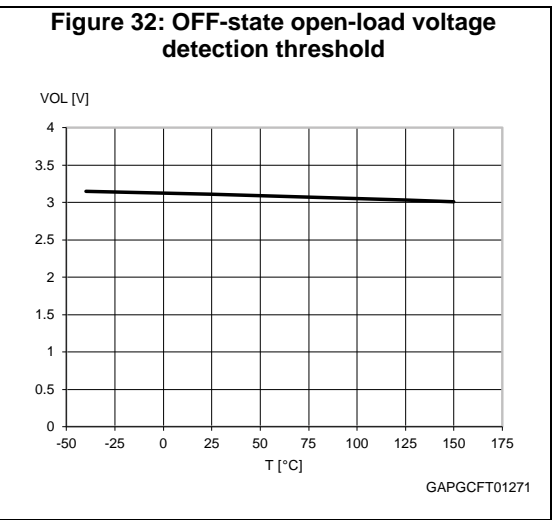
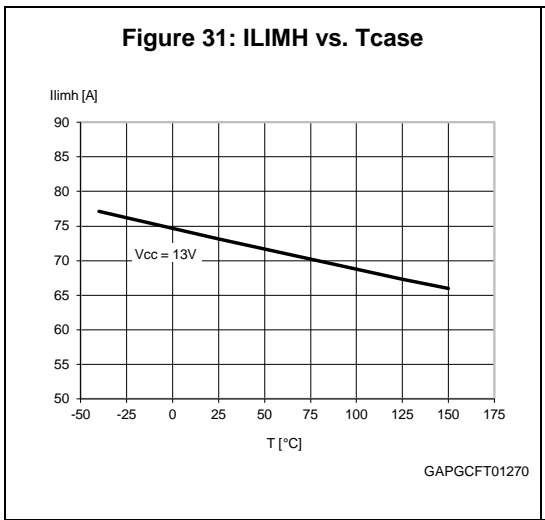
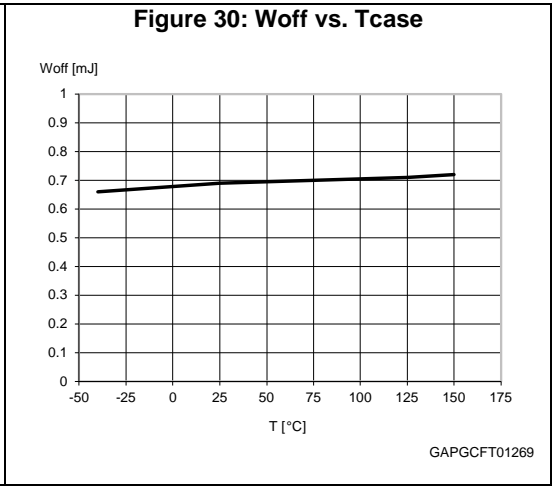
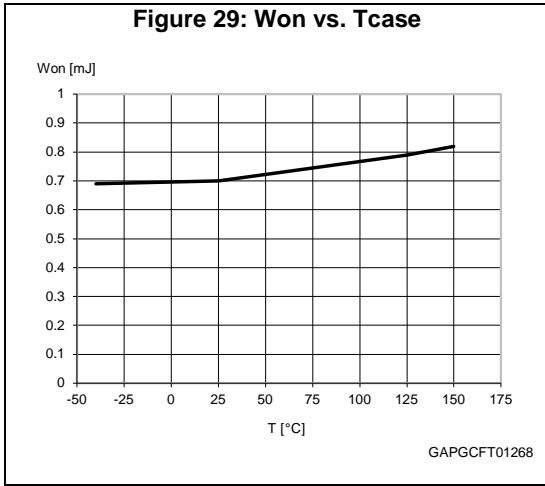

3 Protections

3.1 Power limitation

The basic working principle of this protection consists of an indirect measurement of the junction temperature swing ΔT_j through the direct measurement of the spatial temperature gradient on the device surface in order to automatically shut off the output MOSFET as soon as ΔT_j exceeds the safety level of ΔT_{j_SD} . According to the voltage level on the FaultRST pin, the output MOSFET switches on and cycles with a thermal hysteresis according to the maximum instantaneous power which can be handled (FaultRST = Low) or remains off (FaultRST = High). The protection prevents fast thermal transient effects and, consequently, reduces thermo-mechanical fatigue.

3.2 Thermal shutdown

In case the junction temperature of the device exceeds the maximum allowed threshold (typically 175°C), it automatically switches off and the diagnostic indication is triggered. According to the voltage level on the FaultRST pin, the device switches on again as soon as its junction temperature drops to T_R (FaultRST = Low) or remains off (FaultRST = High).

3.3 Current limitation

The device is equipped with an output current limiter in order to protect the silicon as well as the other components of the system (e.g. bonding wires, wiring harness, connectors, loads, etc.) from excessive current flow. Consequently, in case of short circuit, overload or during load power-up, the output current is clamped to a safety level, I_{LIMH} , by operating the output power MOSFET in the active region.

3.4 Negative voltage clamp

In case the device drives inductive load, the output voltage reaches a negative value during turn off. A negative voltage clamp structure limits the maximum negative voltage to a certain value, V_{DEMAG} , allowing the inductor energy to be dissipated without damaging the device.

4.1.1 Diode (DGND) in the ground line

A resistor (typ. $R_{\text{GND}} = 4.7 \text{ k}\Omega$) should be inserted in parallel to D_{GND} if the device drives an inductive load.

This small signal diode can be safely shared amongst several different HSDs. Also in this case, the presence of the ground network produces a shift ($\approx 600 \text{ mV}$) in the input threshold and in the status output values if the microprocessor ground is not common to the device ground. This shift does not vary if more than one HSD shares the same diode/resistor network.

4.2 Immunity against transient electrical disturbances

The immunity of the device against transient electrical emissions, conducted along the supply lines and injected into the V_{CC} pin, is tested in accordance with ISO 7637-2:2011 (E) and ISO 16750-2:2010.

The related function performance status classification is shown in [Table 12: "ISO 7637-2 - electrical transient conduction along supply line"](#).

Test pulses are applied directly to DUT (Device Under Test) both in ON and OFF-state and in accordance to ISO 7637-2:2011(E), chapter 4. The DUT is intended as the present device only, without components and accessed through V_{CC} and GND terminals.

Status II is defined in ISO 7637-1 Function Performance Status Classification (FPSC) as follows: "The function does not perform as designed during the test but returns automatically to normal operation after the test".

Table 12: ISO 7637-2 - electrical transient conduction along supply line

Test Pulse 2011(E)	Test pulse severity level with Status II functional performance status		Minimum number of pulses or test time	Burst cycle / pulse repetition time		Pulse duration and pulse generator internal impedance
	Level	$U_s^{(1)}$		min	max	
1	III	-112V	500 pulses	0,5 s		2ms, 10 Ω
2a	III	+55V	500 pulses	0,2 s	5 s	50 μ s, 2 Ω
3a	IV	-220V	1h	90 ms	100 ms	0.1 μ s, 50 Ω
3b	IV	+150V	1h	90 ms	100 ms	0.1 μ s, 50 Ω
4 ⁽²⁾	IV	-7V	1 pulse			100ms, 0.01 Ω
Load dump according to ISO 16750-2:2010						
Test B ⁽³⁾		40V	5 pulse	1 min		400ms, 2 Ω

Notes:

⁽¹⁾ U_s is the peak amplitude as defined for each test pulse in ISO 7637-2:2011(E), chapter 5.6.

⁽²⁾Test pulse from ISO 7637-2:2004(E).

⁽³⁾With 40 V external suppressor referred to ground ($-40^\circ\text{C} < T_j < 150^\circ\text{C}$).

4.3 MCU I/Os protection

If a ground protection network is used and negative transients are present on the V_{CC} line, the control pins will be pulled negative. ST suggests to insert a resistor (R_{prot}) in line both to prevent the microcontroller I/O pins to latch-up and to protect the HSD inputs.

4.4.1 Principle of Multisense signal generation

Figure 38: MultiSense block diagram

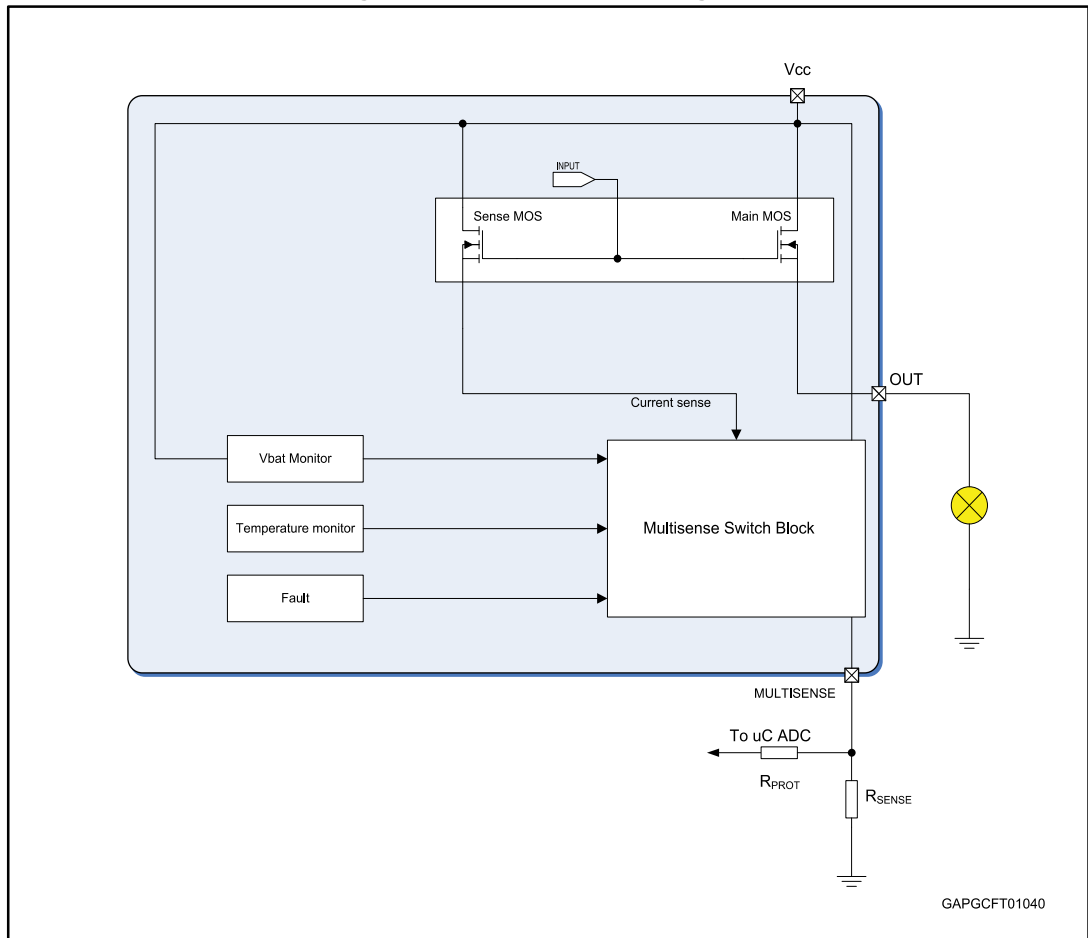

Current monitor

When current mode is selected in the MultiSense, this output is capable to provide:

- Current mirror proportional to the load current in normal operation, delivering current proportional to the load according to known ratio named **K**
- Diagnostics flag in fault conditions delivering fixed voltage V_{SENSEH}

The current delivered by the current sense circuit, I_{SENSE} , can be easily converted to a voltage V_{SENSE} by using an external sense resistor, R_{SENSE} , allowing continuous load monitoring and abnormal condition detection.

Normal operation (channel ON, no fault, SEn active)

While device is operating in normal conditions (no fault intervention), V_{SENSE} calculation can be done using simple equations

Current provided by MultiSense output: $I_{SENSE} = I_{OUT}/K$

Voltage on R_{SENSE} : $V_{SENSE} = R_{SENSE} \cdot I_{SENSE} = R_{SENSE} \cdot I_{OUT}/K$

Where:

- V_{SENSE} is voltage measurable on R_{SENSE} resistor
- I_{SENSE} is current provided from MultiSense pin in current output mode

- I_{OUT} is current flowing through output
- K factor represents the ratio between PowerMOS cells and SenseMOS cells; its spread includes geometric factor spread, current sense amplifier offset and process parameters spread of overall circuitry specifying ratio between I_{OUT} and I_{SENSE} .

Failure flag indication

In case of power limitation/overtemperature, the fault is indicated by the MultiSense pin which is switched to a “current limited” voltage source, V_{SENSEH} .

In any case, the current sourced by the MultiSense in this condition is limited to I_{SENSEH} .

The typical behavior in case of overload or hard short circuit is shown in *Waveforms section*.

Figure 39: Analogue HSD – open-load detection in off-state

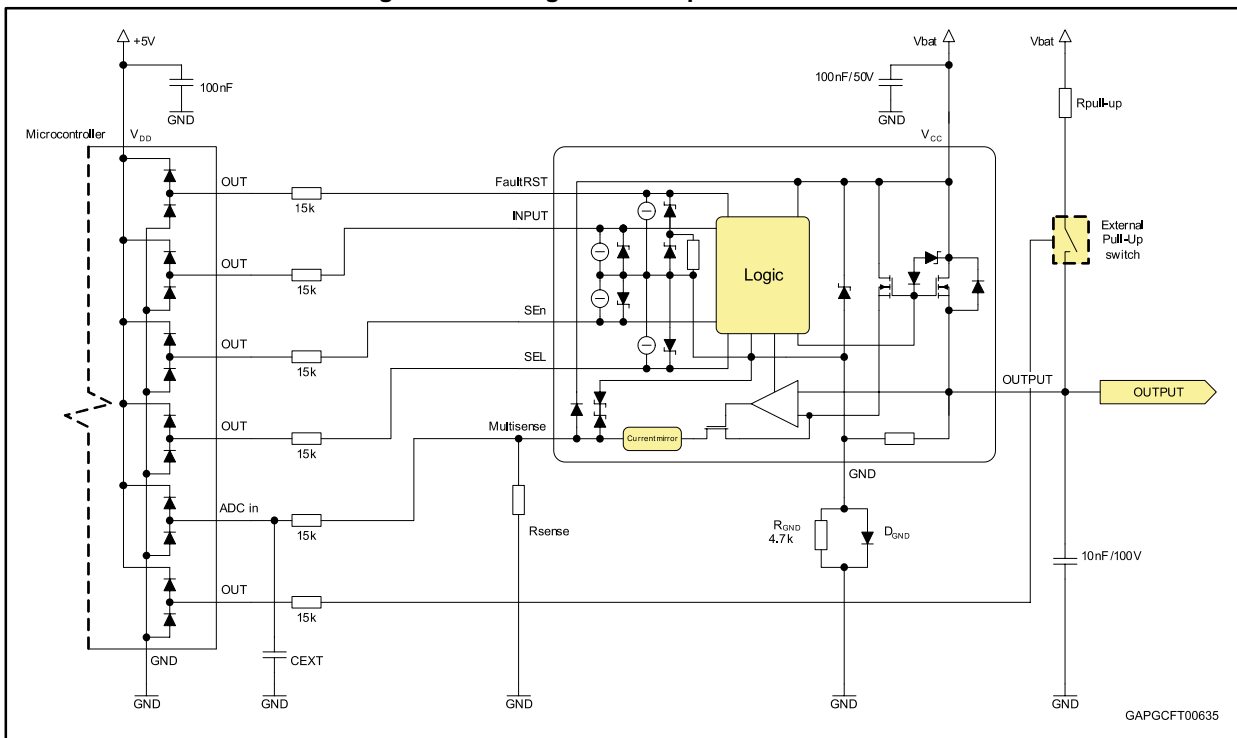

Figure 40: Open-load / short to VCC condition

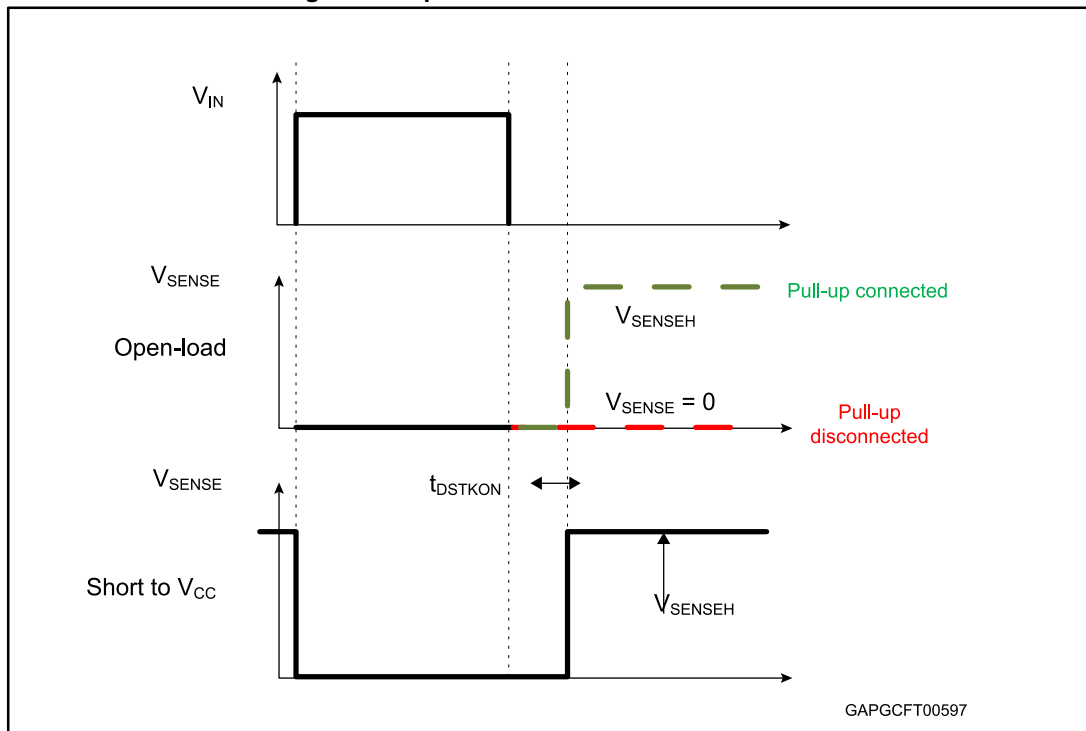

Table 13: MultiSense pin levels in off-state

Condition	Output	MultiSense	SEn
Open-load	$V_{OUT} > V_{OL}$	Hi-Z	L
		V_{SENSEH}	H
	$V_{OUT} < V_{OL}$	Hi-Z	L
		0	H
Short to V_{CC}	$V_{OUT} > V_{OL}$	Hi-Z	L
		V_{SENSEH}	H
Nominal	$V_{OUT} < V_{OL}$	Hi-Z	L
		0	H

4.4.2 TCASE and VCC monitor

In this case, MultiSense output operates in voltage mode and output level is referred to device GND. Care must be taken in case a GND network protection is used, because a voltage shift is generated between device GND and the microcontroller input GND reference.

Figure 41: "GND voltage shift" shows link between $V_{MEASURED}$ and real V_{SENSE} signal.

Figure 41: GND voltage shift

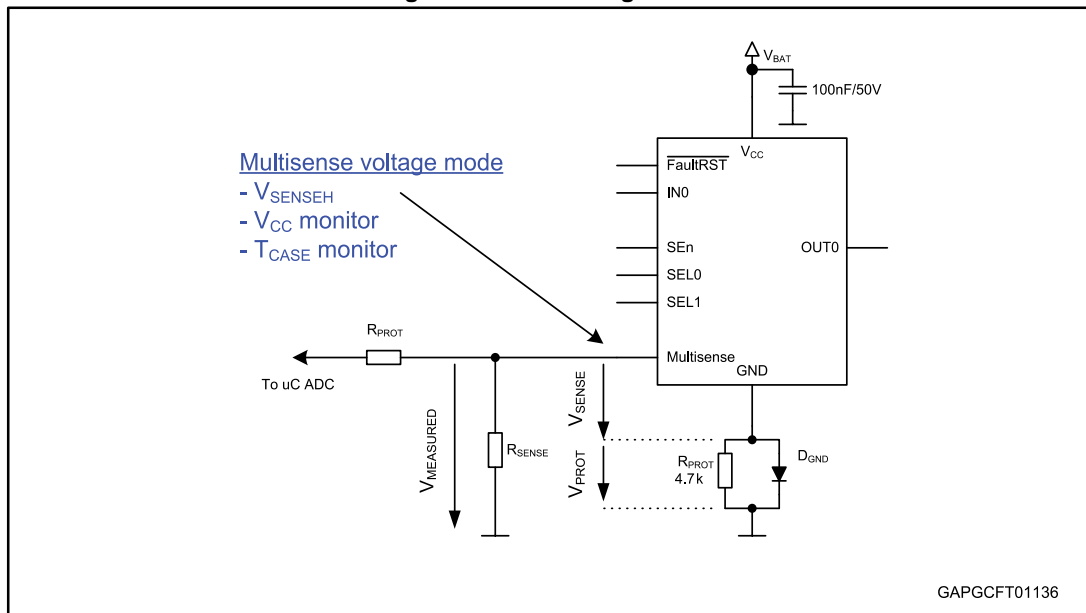

V_{CC} monitor

Battery monitoring channel provides $V_{SENSE} = V_{CC} / 4$.

Case temperature monitor

Case temperature monitor is capable to provide information about the actual device temperature. Since a diode is used for temperature sensing, the following equation describes the link between temperature and output V_{SENSE} level:

$$V_{SENSE_TC}(T) = V_{SENSE_TC}(T_0) + dV_{SENSE_TC} / dT * (T - T_0)$$

where dV_{SENSE_TC} / dT ~ typically -5.5 mV/K (for temperature range (-40 °C to 150 °C)).

4.4.3 Short to V_{CC} and OFF-state open-load detection

Short to V_{CC}

A short circuit between V_{CC} and output is indicated by the relevant current sense pin set to V_{SENSEH} during the device off-state. Small or no current is delivered by the current sense during the on-state depending on the nature of the short circuit.

OFF-state open-load with external circuitry

Detection of an open-load in off mode requires an external pull-up resistor R_{PU} connecting the output to a positive supply voltage V_{PU}.

It is preferable V_{PU} to be switched off during the module standby mode in order to avoid the overall standby current consumption to increase in normal conditions, i.e. when load is connected.

R_{PU} must be selected in order to ensure $V_{OUT} > V_{OLmax}$ in accordance with the following equation:

Equation

$$R_{PU} < \frac{V_{PU} - 4}{I_{L(off2)min @ 4V}}$$

5 Maximum demagnetization energy (VCC = 16 V)

Figure 42: Maximum turn off current versus inductance

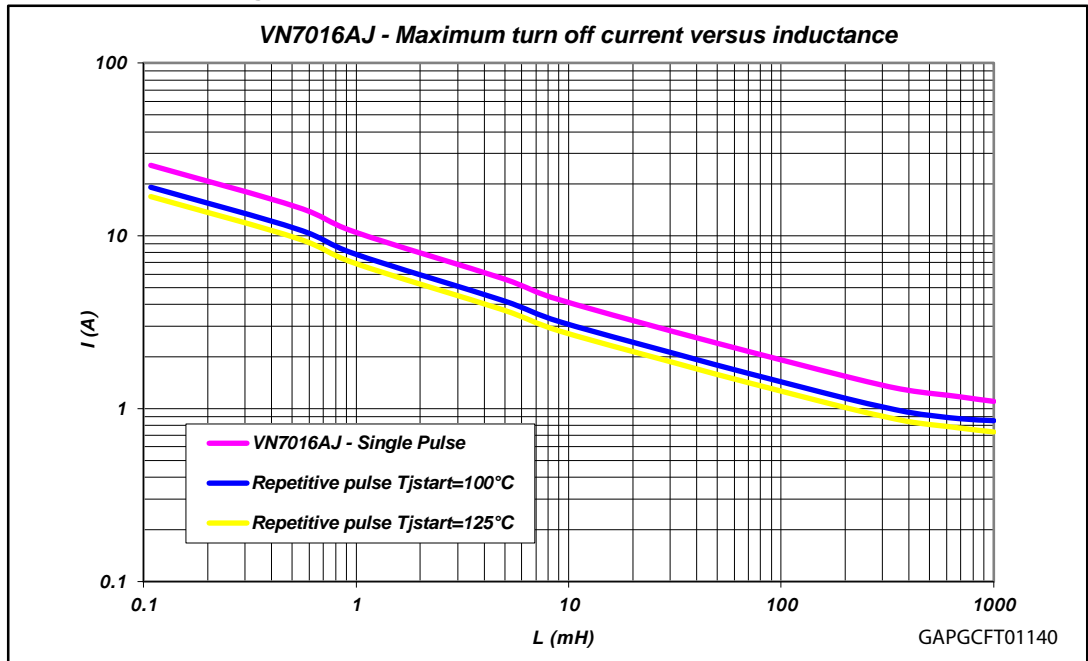

Values are generated with $R_L = 0 \Omega$.

In case of repetitive pulses, T_{jstart} (at the beginning of each demagnetization) of every pulse must not exceed the temperature specified above for curves A and B.

6 Package and PCB thermal data

6.1 PowerSSO-16 thermal data

Figure 43: PowerSSO-16 on two-layers PCB (2s0p to JEDEC JESD 51-5)

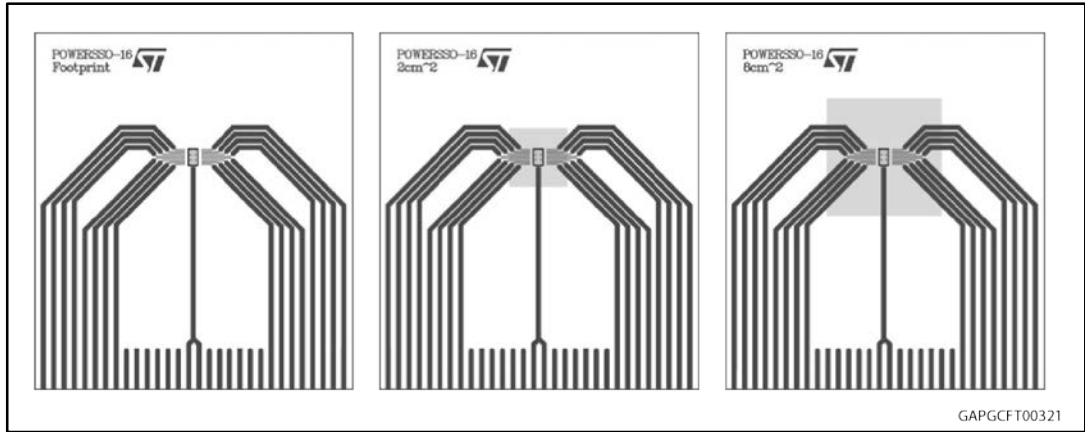

Figure 44: PowerSSO-16 on four-layers PCB (2s2p to JEDEC JESD 51-7)

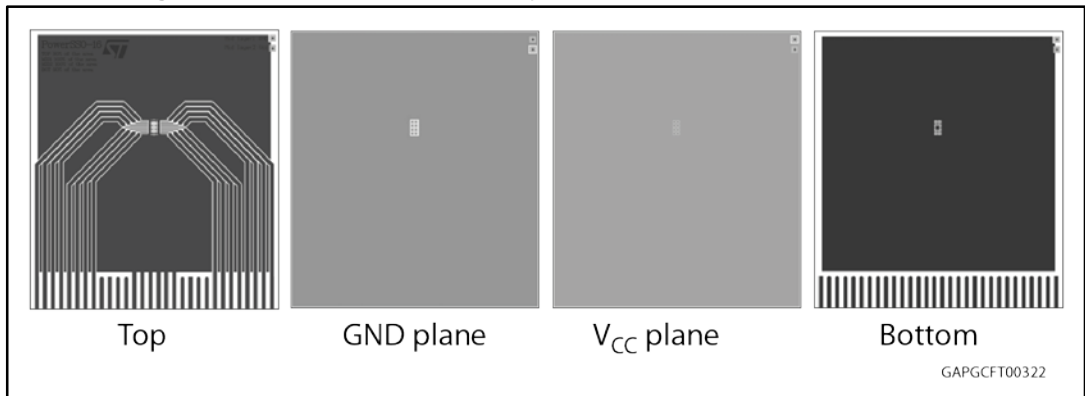

Table 14: PCB properties

Dimension	Value
Board finish thickness	1.6 mm +/- 10%
Board dimension	77 mm x 86 mm
Board Material	FR4
Copper thickness (top and bottom layers)	0.070 mm
Copper thickness (inner layers)	0.035 mm
Thermal via separation	1.2 mm
Thermal via diameter	0.3 mm +/- 0.08 mm
Copper thickness on vias	0.025 mm
Footprint dimension (top layer)	2.2 mm x 3.9 mm
Heatsink copper area dimension (bottom layer)	Footprint, 2 cm ² or 8 cm ²

Figure 45: Rthj-amb vs PCB copper area in open box free air condition (one channel on)

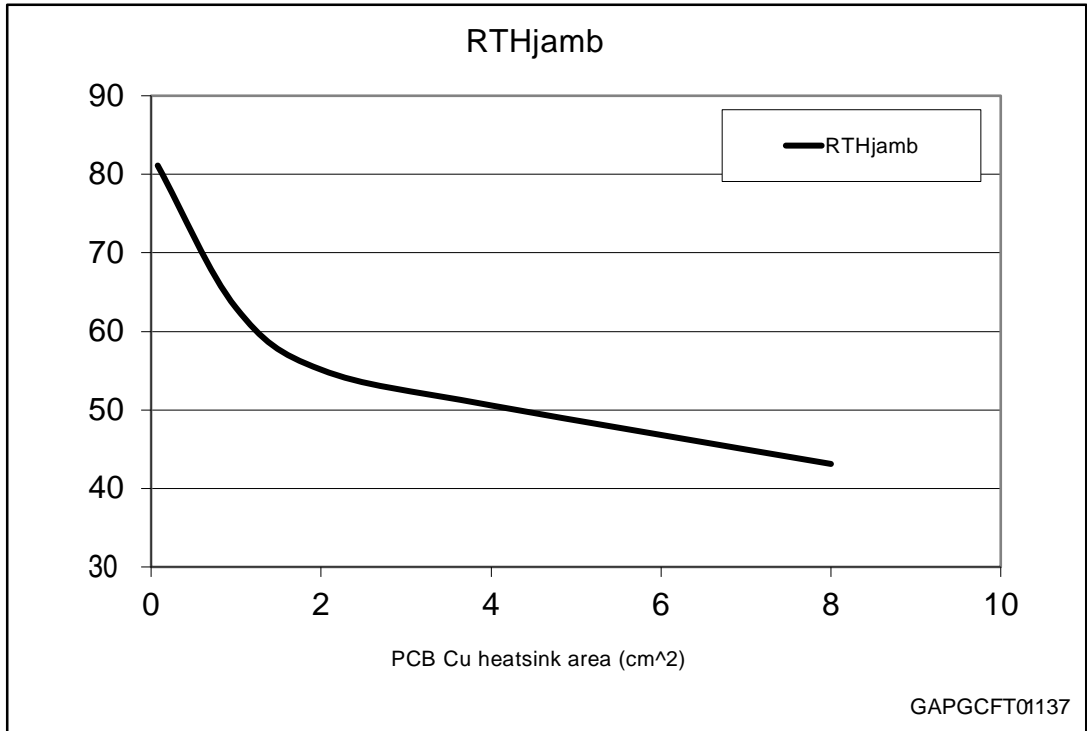
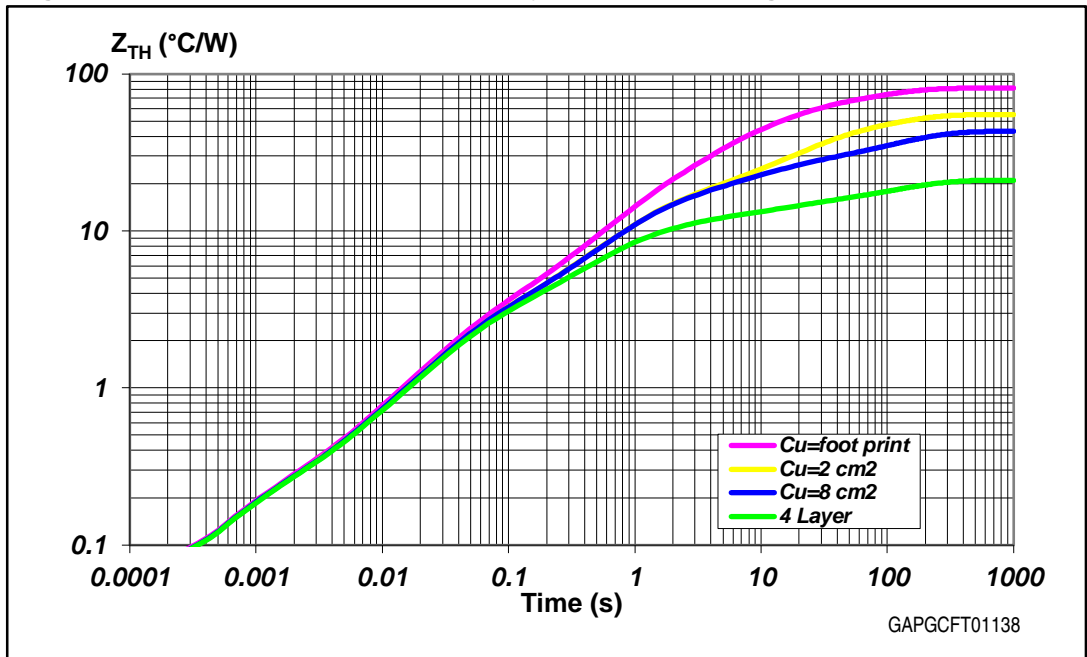

Figure 46: PowerSSO-16 thermal impedance junction ambient single pulse (one channel on)



Equation: pulse calculation formula

$$Z_{TH\delta} = R_{TH} \cdot \delta + Z_{THtp} (1 - \delta)$$

where $\delta = t_p/T$

Figure 47: Thermal fitting model of a double-channel HSD in PowerSSO-16

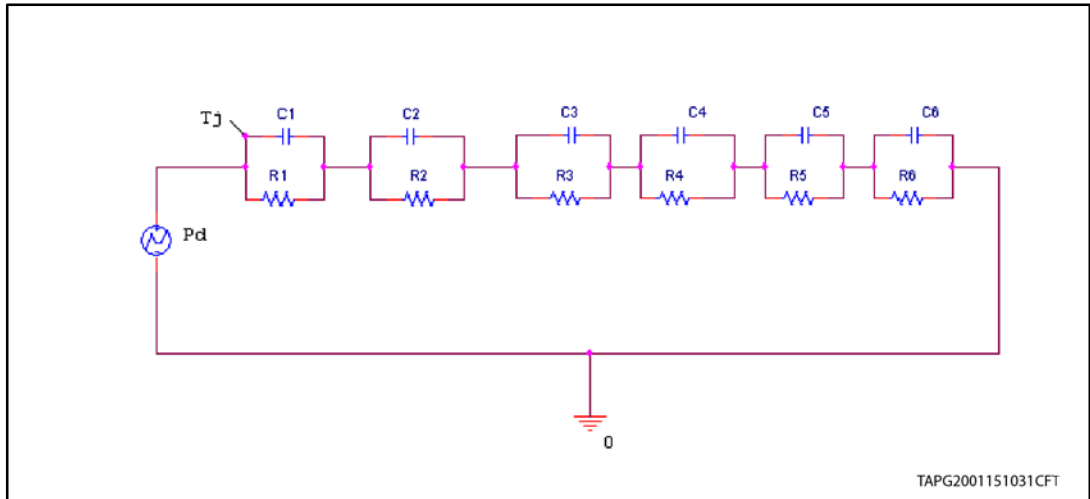

The fitting model is a simplified thermal tool and is valid for transient evolutions where the embedded protections (power limitation or thermal cycling during thermal shutdown) are not triggered.

Table 15: Thermal parameters

Area/island (cm ²)	Footprint	2	8	4L
R1 (°C/W)	0.15			
R2 (°C/W)	1.9			
R3 (°C/W)	7	7	7	5
R4 (°C/W)	16	6	6	4
R5 (°C/W)	30	20	10	3
R6 (°C/W)	26	20	18	7
C1 (W.s/°C)	0.005			
C2 (W.s/°C)	0.02			
C3 (W.s/°C)	0.1			
C4 (W.s/°C)	0.2	0.3	0.3	0.4
C5 (W.s/°C)	0.4	1	1	4
C6 (W.s/°C)	3	5	7	18

7 Package information

In order to meet environmental requirements, ST offers these devices in different grades of ECOPACK® packages, depending on their level of environmental compliance. ECOPACK® specifications, grade definitions and product status are available at: www.st.com. ECOPACK® is an ST trademark.

7.1 PowerSSO-16 package information

Figure 48: PowerSSO-16 package dimensions

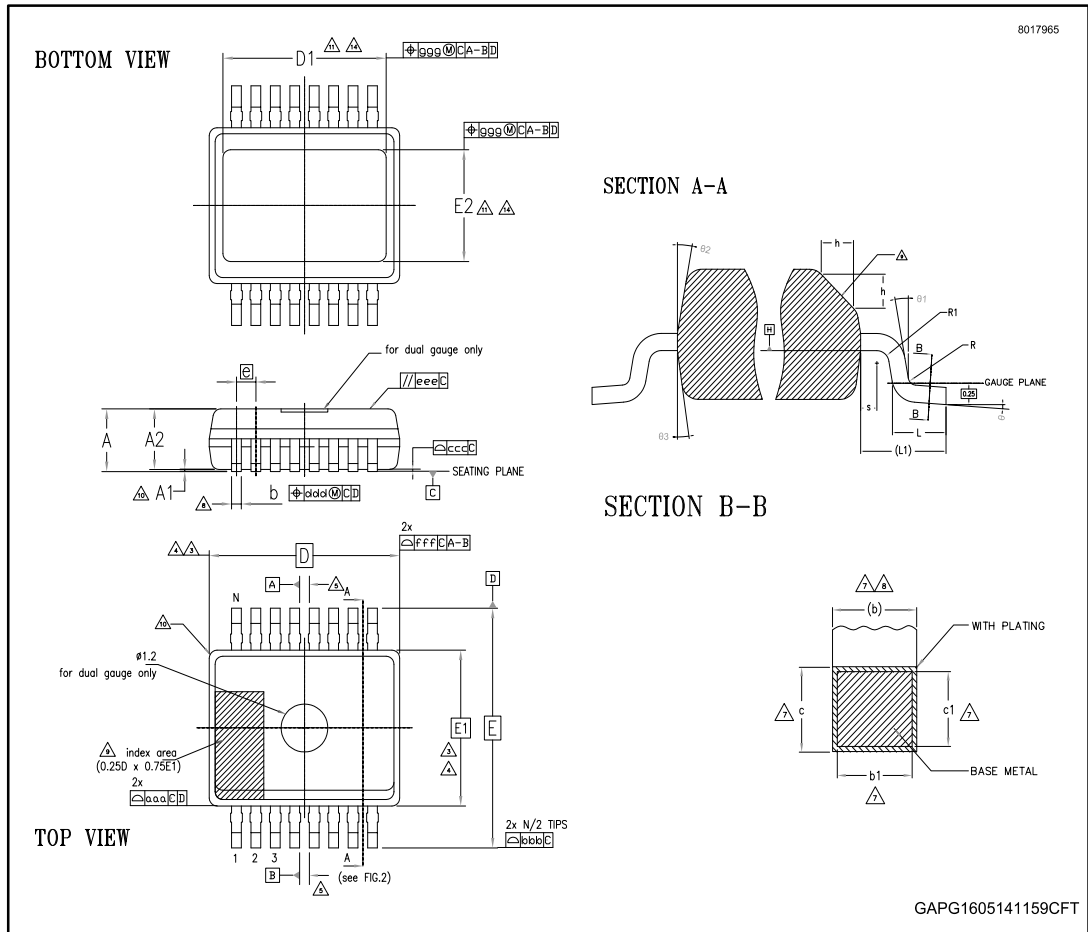

Table 16: PowerSSO-16 mechanical data

Symbol	Millimeters		
	Min.	Typ.	Max.
Θ	0°		8°
$\Theta 1$	0°		
$\Theta 2$	5°		15°
$\Theta 3$	5°		15°
A			1.70
A1	0.00		0.10
A2	1.10		1.60

Symbol	Millimeters		
	Min.	Typ.	Max.
b	0.20		0.30
b1	0.20	0.25	0.28
c	0.19		0.25
c1	0.19	0.20	0.23
D	4.9 BSC		
D1	3.60		4.20
e	0.50 BSC		
E	6.00 BSC		
E1	3.90 BSC		
E2	1.90		2.50
h	0.25		0.50
L	0.40	0.60	0.85
L1	1.00 REF		
N	16		
R	0.07		
R1	0.07		
S	0.20		
Tolerance of form and position			
aaa	0.10		
bbb	0.10		
ccc	0.08		
ddd	0.08		
eee	0.10		
fff	0.10		
ggg	0.15		

7.2 PowerSSO-16 packing information

Figure 49: PowerSSO-16 reel 13"

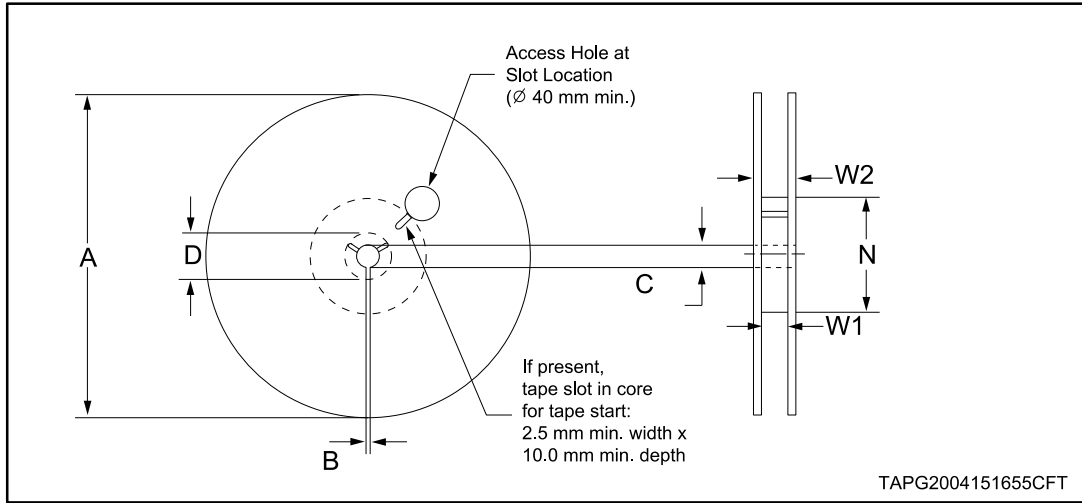

Table 17: Reel dimensions

Description	Value ⁽¹⁾
Base quantity	2500
Bulk quantity	2500
A (max)	330
B (min)	1.5
C (+0.5, -0.2)	13
D (min)	20.2
N	100
W1 (+2 /-0)	12.4
W2 (max)	18.4

Notes:

⁽¹⁾All dimensions are in mm.

Figure 50: PowerSSO-16 carrier tape

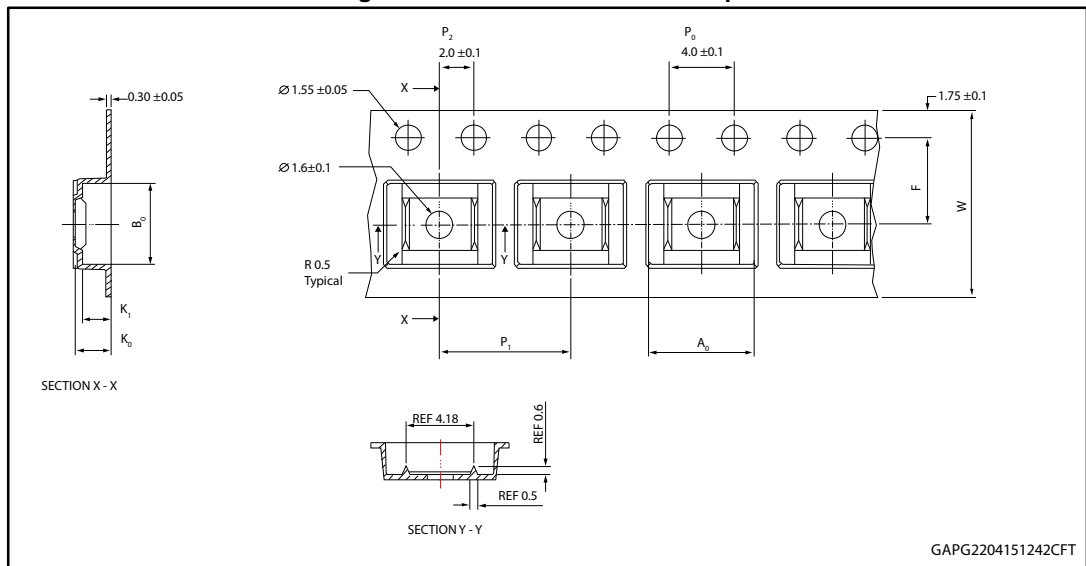

Table 18: PowerSSO-16 carrier tape dimensions

Description	Value ⁽¹⁾
A ₀	6.50 ± 0.1
B ₀	5.25 ± 0.1
K ₀	2.10 ± 0.1
K ₁	1.80 ± 0.1
F	5.50 ± 0.1
P ₁	8.00 ± 0.1
W	12.00 ± 0.3

Notes:

⁽¹⁾All dimensions are in mm.

Figure 51: PowerSSO-16 schematic drawing of leader and trailer tape

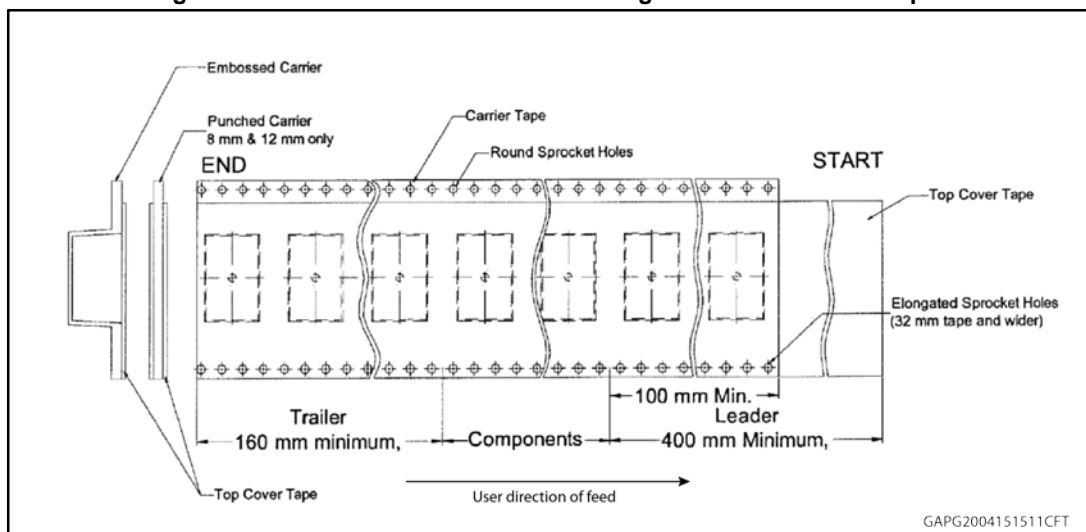

7.3 PowerSSO-16 marking information

Figure 52: PowerSSO-16 marking information

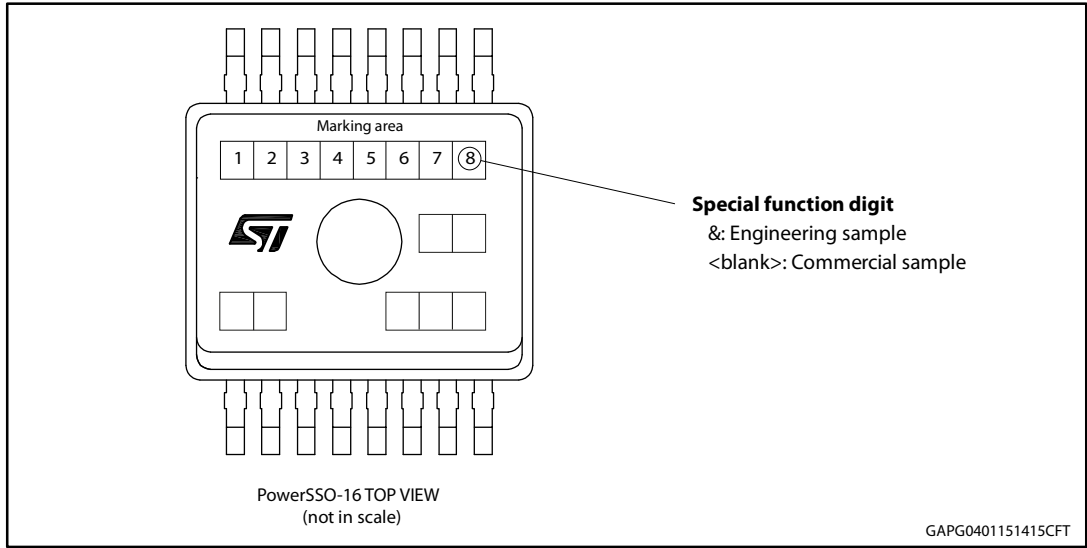

Engineering Samples: these samples can be clearly identified by a dedicated special symbol in the marking of each unit. These samples are intended to be used for electrical compatibility evaluation only; usage for any other purpose may be agreed only upon written authorization by ST. ST is not liable for any customer usage in production and/or in reliability qualification trials.

Commercial Samples: fully qualified parts from ST standard production with no usage restrictions.

8 Order codes

Table 19: Device summary

Package	Order codes
	Tape and reel
PowerSSO-16	VN7016AJTR

9 Revision history

Table 20: Document revision history

Date	Revision	Changes
25-May-2015	1	Initial release.

IMPORTANT NOTICE – PLEASE READ CAREFULLY

STMicroelectronics NV and its subsidiaries ("ST") reserve the right to make changes, corrections, enhancements, modifications, and improvements to ST products and/or to this document at any time without notice. Purchasers should obtain the latest relevant information on ST products before placing orders. ST products are sold pursuant to ST's terms and conditions of sale in place at the time of order acknowledgement.

Purchasers are solely responsible for the choice, selection, and use of ST products and ST assumes no liability for application assistance or the design of Purchasers' products.

No license, express or implied, to any intellectual property right is granted by ST herein.

Resale of ST products with provisions different from the information set forth herein shall void any warranty granted by ST for such product.

ST and the ST logo are trademarks of ST. All other product or service names are the property of their respective owners.

Information in this document supersedes and replaces information previously supplied in any prior versions of this document.

© 2015 STMicroelectronics – All rights reserved

Компания «Океан Электроники» предлагает заключение долгосрочных отношений при поставках импортных электронных компонентов на взаимовыгодных условиях!

Наши преимущества:

- Поставка оригинальных импортных электронных компонентов напрямую с производств Америки, Европы и Азии, а так же с крупнейших складов мира;
- Широкая линейка поставок активных и пассивных импортных электронных компонентов (более 30 млн. наименований);
- Поставка сложных, дефицитных, либо снятых с производства позиций;
- Оперативные сроки поставки под заказ (от 5 рабочих дней);
- Экспресс доставка в любую точку России;
- Помощь Конструкторского Отдела и консультации квалифицированных инженеров;
- Техническая поддержка проекта, помощь в подборе аналогов, поставка прототипов;
- Поставка электронных компонентов под контролем ВП;
- Система менеджмента качества сертифицирована по Международному стандарту ISO 9001;
- При необходимости вся продукция военного и аэрокосмического назначения проходит испытания и сертификацию в лаборатории (по согласованию с заказчиком);
- Поставка специализированных компонентов военного и аэрокосмического уровня качества (Xilinx, Altera, Analog Devices, Intersil, Interpoint, Microsemi, Actel, Aeroflex, Peregrine, VPT, Syfer, Eurofarad, Texas Instruments, MS Kennedy, Miteq, Cobham, E2V, MA-COM, Hittite, Mini-Circuits, General Dynamics и др.);

Компания «Океан Электроники» является официальным дистрибьютором и эксклюзивным представителем в России одного из крупнейших производителей разъемов военного и аэрокосмического назначения «JONHON», а так же официальным дистрибьютором и эксклюзивным представителем в России производителя высокотехнологичных и надежных решений для передачи СВЧ сигналов «FORSTAR».



JONHON

«JONHON» (основан в 1970 г.)

Разъемы специального, военного и аэрокосмического назначения:

(Применяются в военной, авиационной, аэрокосмической, морской, железнодорожной, горно- и нефтедобывающей отраслях промышленности)

«FORSTAR» (основан в 1998 г.)

ВЧ соединители, коаксиальные кабели, кабельные сборки и микроволновые компоненты:

(Применяются в телекоммуникациях гражданского и специального назначения, в средствах связи, РЛС, а так же военной, авиационной и аэрокосмической отраслях промышленности).



Телефон: 8 (812) 309-75-97 (многоканальный)

Факс: 8 (812) 320-03-32

Электронная почта: ocean@oceanchips.ru

Web: <http://oceanchips.ru/>

Адрес: 198099, г. Санкт-Петербург, ул. Калинина, д. 2, корп. 4, лит. А