

700 Series Platinum RTDs

Temperature Sensors

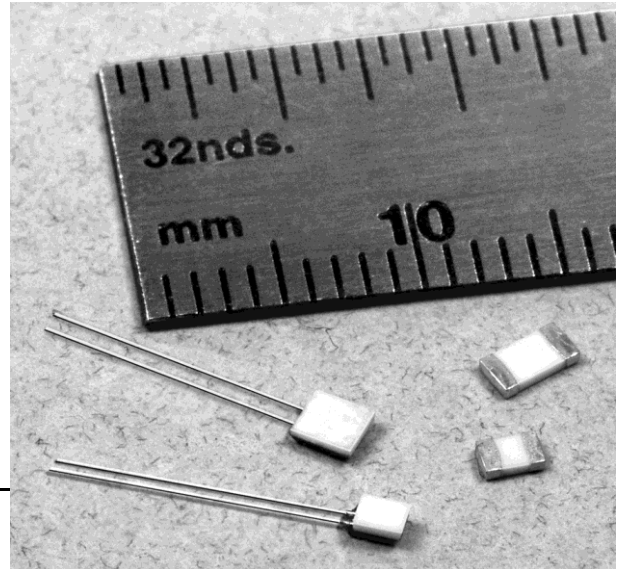

DESCRIPTION

The 700 Series Platinum RTD (Resistance Temperature Detector) is an economical, miniature temperature sensor. The series is available in two different package configurations, leaded and SMT (Surface Mount Technology). Two sizes are available for each configuration, with the SMT available in industry standard 0805 and 1206 packages.

The 700 Series has 100 Ω and 1000 Ω base resistances and is available in both the 3750 ppm/K and 3850 ppm/K temperature coefficients (375 and 385 alphas). The tolerances of the 700 Series meet DIN class A, DIN class B and DIN class 2B industry-standards.

The 700 Series is RoHS (Restriction of Hazardous Substances) compliant (EU Directive 2002/95/EC).

FEATURES

- Linear resistance vs temperature
- High accuracy
- Interchangeable
- Excellent stability
- Fast time response
- Wide temperature range
- RoHS compliant

POTENTIAL APPLICATIONS

- HVAC (Heating Ventilation and Air Conditioning)
- Electronic assemblies
- Process control
- Appliances
- Automotive
- Instrumentation

700 Series Platinum RTDs

Table 1. Specifications

	700-*	701-*
Temperature range	Class B and 2B: -70 °C to 500 °C (continuous operation) Class A: -30 °C to 300 °C	Class B and 2B: -70 °C to 500 °C (continuous operation) Class A: -30 °C to 300 °C
Leads	Pt-clad Ni wire	Pt-clad Ni wire
Long-term stability	max. R ₀ drift 0.04% after 1000 h at 500 °C	max. R ₀ drift 0.04% after 1000 h at 500 °C
Vibration resistance	at least 40 g acceleration at 10 Hz to 2000 Hz, depends on installation	at least 40 g acceleration at 10 Hz to 2000 Hz, depends on installation
Shock resistance	at least 100 g acceleration with 8 ms half sine wave, depends on installation	at least 100 g acceleration with 8 ms half sine wave, depends on installation
Environmental conditions	unhoused for dry environments only	unhoused for dry environments only
Insulation resistance	>100 MΩ at 20 °C; >2 MΩ at 500 °C	>100 MΩ at 20 °C; >2 MΩ at 500 °C
Self heating	0.4 K/mW at 0 °C	0.6 K/mW at 0 °C
Response time	water current (v=0.4 m/s): t _{0.5} =0.05 s; t _{0.9} =0.15 s air stream (V=2 m/s): t _{0.5} =3.0 s; t _{0.9} =10.0 s	water current (v=0.4 m/s): t _{0.5} =0.04 s; t _{0.9} =0.12 s air stream (V=2 m/s): t _{0.5} =2.2 s; t _{0.9} =7.0 s
Measuring current	100 Ω: 0.3 mA to 1.0 mA 1000 Ω: 0.1 mA to 0.3 mA	100 Ω: 0.3 mA to 1.0 mA 1000 Ω: 0.1 mA to 0.3 mA
Packaging	anti-static plastic bag	anti-static plastic bag

	702-*	703-*
Temperature range	Class B: -50 °C to 130 °C (continuous operation)	Class B: -50 °C to 130 °C (continuous operation)
Soldering connection	end-termination galvanic tin-plated with Ni barrier layer	end-termination galvanic tin-plated with Ni barrier layer
Long-term stability	max. R ₀ drift 0.06 % after 1000 h at 130 °C	max. R ₀ drift 0.06 % after 1000 h at 130 °C
Environmental conditions	unhoused for dry environments only	unhoused for dry environments only
Insulation resistance	>100 MΩ at 20 °C; >2 MΩ at 130 °C (glass covering)	>100 MΩ at 20 °C; >2 MΩ at 130 °C (glass covering)
Self heating	0.8 K/mW at 0 °C	0.4 K/mW at 0 °C
Response time	water current (v=0.4 m/s): t _{0.5} =0.10 s; t _{0.9} =0.25 s air stream (V = 2 m/s): t _{0.5} =2.5 s; t _{0.9} =8.0 s	water current (v=0.4 m/s): t _{0.5} =0.15 s; t _{0.9} =0.30 s air stream (V = 2 m/s): t _{0.5} =3.5 s; t _{0.9} =10.0 s
Measuring current	100 Ω: 0.3 mA to 1.0 mA 1000 Ω: 0.1 mA to 0.3 mA	100 Ω: 0.3 mA to 1.0 mA 1000 Ω: 0.1 mA to 0.3 mA
Processing instructions	face up mounting: reflow soldering or wave soldering, e.g. double wave ≤8 s/235 °C	face up mounting: reflow soldering or wave soldering, e.g. double wave ≤8 s/235 °C
Packaging	face-up in blister reel	face-up in blister reel

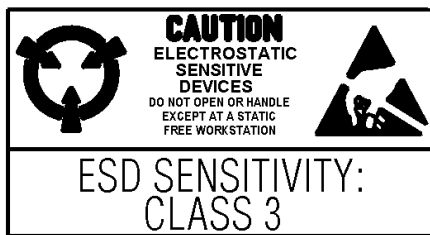

Temperature Sensors

Figure 1. Mounting Dimensions (For reference only mm/[in].)

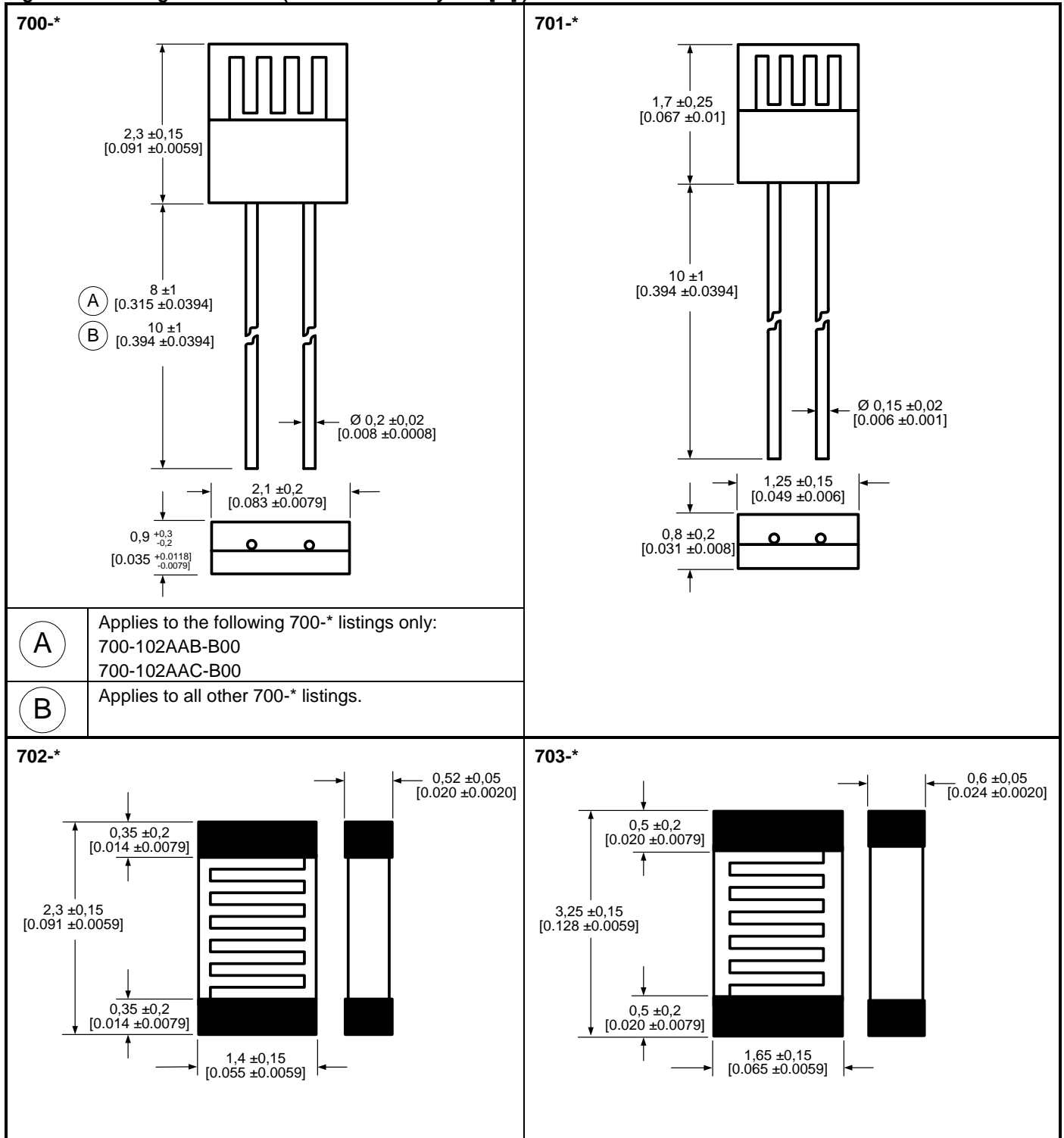

Order Guide

Catalog Listing	Package Style and Size mm [in]	Nominal Resistance at 0 °C	Temp. Coefficient	Temp. Range (°C)	Tolerance	Termination
700-101BAA-B00	chip, 2,1 w x 2,3 l x 0,9 thk [0.083 w x 0.091 l x 0.035 thk]	100 Ω	3850 ppm/K	-70 to 500	DIN EN 60751, class A (R ₀ : ±0.06 %)	bare Pt-clad Ni wire, adjacent leads
700-101BAB-B00	chip, 2,1 w x 2,3 l x 0,9 thk [0.083 w x 0.091 l x 0.035 thk]	100 Ω	3850 ppm/K	-70 to 500	DIN EN 60751, class B (R ₀ : ±0.12 %)	bare Pt-clad Ni wire, adjacent leads
700-102AAB-B00	chip, 2,1 w x 2,3 l x 0,9 thk [0.083 w x 0.091 l x 0.035 thk]	1000 Ω	3750 ppm/K	-70 to 500	DIN EN 60751, class B (R ₀ : ±0.12 %)	bare Pt-clad Ni wire, adjacent leads
700-102AAC-B00	chip, 2,1 w x 2,3 l x 0,9 thk [0.083 w x 0.091 l x 0.035 thk]	1000 Ω	3750 ppm/K	-70 to 500	DIN EN 60751, class 2B (R ₀ : ±0.24 %)	bare Pt-clad Ni wire, adjacent leads
700-102BAA-B00	chip, 2,1 w x 2,3 l x 0,9 thk [0.083 w x 0.091 l x 0.035 thk]	1000 Ω	3850 ppm/K	-70 to 500	DIN EN 60751, class A (R ₀ : ±0.06 %)	bare Pt-clad Ni wire, adjacent leads
700-102BAB-B00	chip, 2,1 w x 2,3 l x 0,9 thk [0.083 w x 0.091 l x 0.035 thk]	1000 Ω	3850 ppm/K	-70 to 500	DIN EN 60751, class B (R ₀ : ±0.12 %)	bare Pt-clad Ni wire, adjacent leads
701-101BAA-B00	chip, 1,25 w x 1,7 l x 0,8 thk [0.049 w x 0.067 l x 0.031 thk]	100 Ω	3850 ppm/K	-70 to 500	DIN EN 60751, class A (R ₀ : ±0.06 %)	bare Pt-clad Ni wire, adjacent leads
701-101BAB-B00	chip, 1,25 w x 1,7 l x 0,8 thk [0.049 w x 0.067 l x 0.031 thk]	100 Ω	3850 ppm/K	-70 to 500	DIN EN 60751, class B (R ₀ : ±0.12 %)	bare Pt-clad Ni wire, adjacent leads
701-102AAB-B00	chip, 1,25 w x 1,7 l x 0,8 thk [0.049 w x 0.067 l x 0.031 thk]	1000 Ω	3750 ppm/K	-70 to 500	DIN EN 60751, class B (R ₀ : ±0.12 %)	bare Pt-clad Ni wire, adjacent leads
701-102BAB-B00	chip, 1,25 w x 1,7 l x 0,8 thk [0.049 w x 0.067 l x 0.031 thk]	1000 Ω	3850 ppm/K	-70 to 500	DIN EN 60751, class B (R ₀ : ±0.12 %)	bare Pt-clad Ni wire, adjacent leads
702-101BBB-A00	SMD 0805, 1,4 w x 2,3 l x 0,52 thk [0.055 w x 0.091 l x 0.020]	100 Ω	3850 ppm/K	-50 to 130	DIN EN 60751, class B (R ₀ : ±0.12 %)	end termination, galvanic Sn-plated with Ni barrier layer
702-102BBB-A00	SMD 0805, 1,4 w x 2,3 l x 0,52 thk [0.055 w x 0.091 l x 0.020]	1000 Ω	3850 ppm/K	-50 to 130	DIN EN 60751, class B (R ₀ : ±0.12 %)	end termination, galvanic Sn-plated with Ni barrier layer
703-101BBB-A00	SMD 1206, 1,65 w x 3,25 l x 0,6 thk [0.065 w x 0.128 l x 0.024]	100 Ω	3850 ppm/K	-50 to 130	DIN EN 60751, class B (R ₀ : ±0.12 %)	end termination, galvanic Sn-plated with Ni barrier layer
703-102BBB-A00	SMD 1206, 1,65 w x 3,25 l x 0,6 thk [0.065 w x 0.128 l x 0.024]	1000 Ω	3850 ppm/K	-50 to 130	DIN EN 60751, class B (R ₀ : ±0.12 %)	end termination, galvanic Sn-plated with Ni barrier layer

WARNING

PERSONAL INJURY

DO NOT USE these products as safety or emergency stop devices or in any other application where failure of the product could result in personal injury.

Failure to comply with these instructions could result in death or serious injury.

WARNING

MISUSE OF DOCUMENTATION

- The information presented in this product sheet is for reference only. Do not use this document as a product installation guide.
- Complete installation, operation, and maintenance information is provided in the instructions supplied with each product.

Failure to comply with these instructions could result in death or serious injury.

WARRANTY/REMEDY

Honeywell warrants goods of its manufacture as being free of defective materials and faulty workmanship. Honeywell's standard product warranty applies unless agreed to otherwise by Honeywell in writing; please refer to your order acknowledgement or consult your local sales office for specific warranty details. If warranted goods are returned to Honeywell during the period of coverage, Honeywell will repair or replace, at its option, without charge those items it finds defective. **The foregoing is buyer's sole remedy and is in lieu of all other warranties, expressed or implied, including those of merchantability and fitness for a particular purpose. In no event shall Honeywell be liable for consequential, special, or indirect damages.**

While we provide application assistance personally, through our literature and the Honeywell web site, it is up to the customer to determine the suitability of the product in the application.

Specifications may change without notice. The information we supply is believed to be accurate and reliable as of this printing. However, we assume no responsibility for its use.

SALES AND SERVICE

Honeywell serves its customers through a worldwide network of sales offices, representatives and distributors. For application assistance, current specifications, pricing or name of the nearest Authorized Distributor, contact your local sales office or:

E-mail: info.sc@honeywell.com

Internet: www.honeywell.com/sensing

Phone and Fax:

Asia Pacific +65 6355-2828
+65 6445-3033 Fax
Europe +44 (0) 1698 481481
+44 (0) 1698 481676 Fax
Latin America +1-305-805-8188
+1-305-883-8257 Fax
USA/Canada +1-800-537-6945
+1-815-235-6847
+1-815-235-6545 Fax

Sensing and Control

Honeywell

1985 Douglas Drive North

Minneapolis, MN 55422

www.honeywell.com/sensing

009018-3-EN IL50 GLO Printed in USA
April 2010

© 2010 Honeywell International Inc. All rights reserved.

Honeywell

Компания «Океан Электроники» предлагает заключение долгосрочных отношений при поставках импортных электронных компонентов на взаимовыгодных условиях!

Наши преимущества:

- Поставка оригинальных импортных электронных компонентов напрямую с производств Америки, Европы и Азии, а так же с крупнейших складов мира;
- Широкая линейка поставок активных и пассивных импортных электронных компонентов (более 30 млн. наименований);
- Поставка сложных, дефицитных, либо снятых с производства позиций;
- Оперативные сроки поставки под заказ (от 5 рабочих дней);
- Экспресс доставка в любую точку России;
- Помощь Конструкторского Отдела и консультации квалифицированных инженеров;
- Техническая поддержка проекта, помощь в подборе аналогов, поставка прототипов;
- Поставка электронных компонентов под контролем ВП;
- Система менеджмента качества сертифицирована по Международному стандарту ISO 9001;
- При необходимости вся продукция военного и аэрокосмического назначения проходит испытания и сертификацию в лаборатории (по согласованию с заказчиком);
- Поставка специализированных компонентов военного и аэрокосмического уровня качества (Xilinx, Altera, Analog Devices, Intersil, Interpoint, Microsemi, Actel, Aeroflex, Peregrine, VPT, Syfer, Eurofarad, Texas Instruments, MS Kennedy, Miteq, Cobham, E2V, MA-COM, Hittite, Mini-Circuits, General Dynamics и др.);

Компания «Океан Электроники» является официальным дистрибьютором и эксклюзивным представителем в России одного из крупнейших производителей разъемов военного и аэрокосмического назначения «JONHON», а так же официальным дистрибьютором и эксклюзивным представителем в России производителя высокотехнологичных и надежных решений для передачи СВЧ сигналов «FORSTAR».



JONHON

«JONHON» (основан в 1970 г.)

Разъемы специального, военного и аэрокосмического назначения:

(Применяются в военной, авиационной, аэрокосмической, морской, железнодорожной, горно- и нефтедобывающей отраслях промышленности)

«FORSTAR» (основан в 1998 г.)

ВЧ соединители, коаксиальные кабели, кабельные сборки и микроволновые компоненты:

(Применяются в телекоммуникациях гражданского и специального назначения, в средствах связи, РЛС, а так же военной, авиационной и аэрокосмической отраслях промышленности).



Телефон: 8 (812) 309-75-97 (многоканальный)

Факс: 8 (812) 320-03-32

Электронная почта: ocean@oceanchips.ru

Web: <http://oceanchips.ru/>

Адрес: 198099, г. Санкт-Петербург, ул. Калинина, д. 2, корп. 4, лит. А