

Si871x LED EMULATOR INPUT ISOLATOR EVALUATION BOARD USER'S GUIDE

1. Introduction

The Si871x evaluation board allows designers to evaluate Silicon Lab's family of CMOS based LED Emulator Input isolators. The Si871x isolators are pin-compatible, single-channel, drop-in replacements for popular optocouplers with data rates up to 15 Mbps. These devices isolate high-speed signals and offer performance, reliability, and flexibility advantages not available with optocoupler solutions. The Si871x series is based on Silicon Labs' proprietary CMOS isolation technology for low-power and high-speed operation and are resistant to the wear-out effects found in optocouplers that degrade performance with increasing temperature, forward current, and device age. As a result, the Si871x series offer longer service life and dramatically higher reliability compared to optocouplers. Ordering options for the family include a push-pull output stage with or without an output enable pin to select a default output state (Hi-Z, logic-low, or logic-high). The evaluation kit consists of three separately orderable boards with each board featuring either the DIP8, SOIC8, or SDIP6 package. For more information on configuring the isolator itself, see the Si871x product data sheet and as well as application note "AN681: Using the Si87xx Family of Digital Isolators".

1.1. Kit Contents

The Si871x Evaluation Kit contains the following items:

- Si871x based evaluation board as shown in Figures 1 through 3.
- Si871x LED Emulator Input isolator (installed on the evaluation board)
 - Si8718 (DIP8, SOIC8)
 - Si8719 (SDIP6)



Figure 1. Si871x DIP8 Evaluation Board Overview



Figure 2. Si871x SOIC8 Evaluation Board Overview

Si871x-EVB



Figure 3. Si871x SDIP6 Evaluation Board Overview

2. Required Equipment

The following equipment is required to demonstrate the evaluation board:

- 1 digital multimeter
- 2 multimeter test leads (red and black)
- 1 oscilloscope (Tektronix TDS 2024B or equivalent)
- 1 BNC splitter
- 3 coaxial cables
- 1 dc power supply (HP6024A, 30 V dc, 0–100 mA or equivalent)
- 2 BNC to clip converters (red and black)
- 2 Banana to clip wires (red and black)
- 1 Clip to Clip wire (any color)
- 1 function generator (Agilent 33220A, 20 MHz or equivalent)
- Si871x Evaluation Board (board under test)
- Si871x LED Emulator Input Evaluation Board User's Guide (this document)

Si871x-EVB

3. Hardware Overview and Demo

Figure 4 illustrates the connection diagram to demonstrate the Si871x-DIP8 EVB. The other footprint boards demonstrate in a similar fashion. This demo transmits a 500 kHz (5 V peak, 50 percent duty cycle) square wave through the isolator to its output (Vo). In this example, VDD is powered by a 5 V supply. Figure 5 shows a scope shot of CH1 (input) and CH2 (output). Note that if a user wants to evaluate an LED Emulator Input isolator other than the ones prepopulated, this can be accomplished by removing the installed device and replacing it with the desired footprint-compatible isolator device.



Figure 4. Summary Diagram and Test Setup

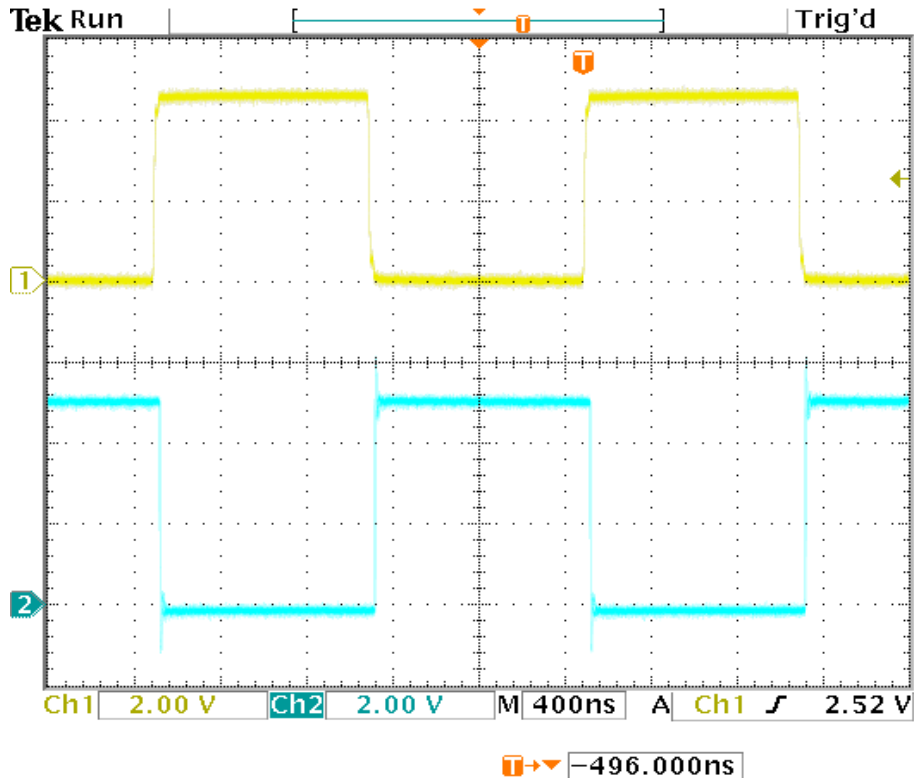

Figure 5. Oscilloscope Display of Input and Output

3.1. Board Jumper Settings

To run the demo, follow the instructions below. Review Figure 4 and Figures 9 through 11 if necessary.

1. If demonstrating the SOIC8 or DIP8 EVB featuring the Si8718, ensure that J2 is installed as shown in Figure 1 or 2.
2. If demonstrating the SDIP6 EVB featuring the Si8719, ensure that J2 is installed as shown in Figure 3.

3.2. DC Supply Configuration

1. Turn OFF the dc power supply and ensure that the output voltage is set to its lowest output voltage.
2. Connect the banana ends of the black and red banana to clip terminated wires to the outputs of the dc supply.
3. Then, connect the clip end of the red and black banana to clip wires to P2. The red wire goes to Pin1. The black wire goes to Pin4.
4. Turn ON the dc power supply.
5. Adjust the dc power supply to provide 5 V on its output.
6. Ensure that the current draw is less than 25 mA. If it is larger, this indicates that either the board or Si871x has been damaged or the supply is connected backwards.

3.3. Wave Form Generator

1. Turn ON the arbitrary waveform generator with the output disengaged.
2. Adjust its output to provide a 500 kHz, 0 to 5 V peak square wave (50 percent duty cycle) to its output.
3. Split the output of the generator with a BNC splitter.
4. From the BNC splitter, connect a coaxial cable to CH1 of the scope. This will be the input.
5. Connect a second coaxial cable to the BNC splitter, and connect a BNC-to-clip converter to the end of the coaxial cable.
6. From here, connect the clip end of the BNC-to-clip converter to P1, Pin1 (red wire here) and Pin3 (black wire here). The positive terminal is Pin1 on P1.
7. Connect one end of a third coaxial cable to a BNC-to-clip converter (note that a scope probe can be used here instead).
8. From here, connect the clip end of the BNC-to-clip converter to P2, Pin3 (red wire here) and Pin4 (black wire here). Vo is on P2 Pin3.
9. Connect the other end of the coaxial cable to CH2 of the oscilloscope. This will be the output.
10. Engage the output of the waveform generator.

3.4. Oscilloscope Setup

1. Turn ON the oscilloscope.
2. Set the scope to Trigger on CH1 and adjust the trigger level to 1 V minimum.
3. Set CH1 and CH2 to 2 V per division.
4. Adjust the seconds/division setting to 400 ns/division.
5. Adjust the level indicator for all channels to properly view each channel as shown in Figure 5.

A 500 kHz square wave should display on Channel 1 of the scope for the input and a 5 V delayed and inverted version of this square wave should display the output on Channel 2, as shown in Figure 5. This concludes the basic demo. For more advanced demos, see the following sections.

3.5. Adjusting Input Signal Frequency and VDD

Now is a good time to explore some additional functionality of the board. From here the user can do the following:

1. Slowly adjust VDD down to 3 V and up to 5.5 V. Then, take the VDD voltage below 2 V. Once below 2 V, it can be seen that the Si871x's UVLO turns on. In this condition, the output should turn off in which case the square wave disappears.
2. Next, adjust the supply back to 5 V.
3. Now, turn this frequency control dial on the signal generator from tens of Hz up to 15 MHz and observe the scope output.

3.6. Enable Test (DIP8 and SOIC8 Only)

The next test demonstrates the ENABLE function of the Si8718. To perform this test:

1. Remove the shunt on J4.
2. Connect a clip-to-clip wire from P2, Pin2 (VE/VL) to P2, Pin4 (GND2).
3. The output should be pulled to Hi-z and the square wave turned off.
4. To resume normal operation, remove the clip-to-clip wire on P2, and reinstall the shunt on J4 (position 1-2).

4. Hardware Overview and Setup

The power and jumper connections descriptions are summarized here:

- P1 External input signal connections to drive the LED Emulator.
- P2 External output signal connections.
- J1 Jumper when installed used to accommodate common-anode drive.
- J2 Jumper when installed used to accommodate common-cathode drive.
- J3, J5 Jumper used to connect external pull-up resistor R4 (Si87xx open-collector output only).
- J4 Jumper used to tie the enable pin to VDD and activate the output default state (Hi-z, logic-low, or logic-high).

4.1. Voltage and Current Sense Test Points

The Si871x evaluation board has several test points. These test points correspond to the respective pins on the Si871x integrated circuits as well as other useful inspection points. See Figures 6 through 8 for a silkscreen overview. See schematics in Figures 9 through 11 for more details.

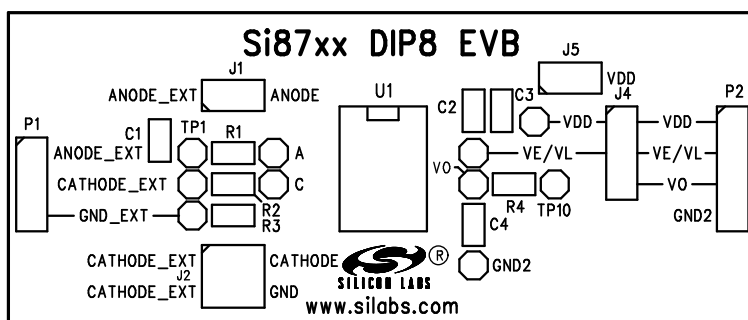

Figure 6. Si87xx DIP8 Evaluation Board Silkscreen

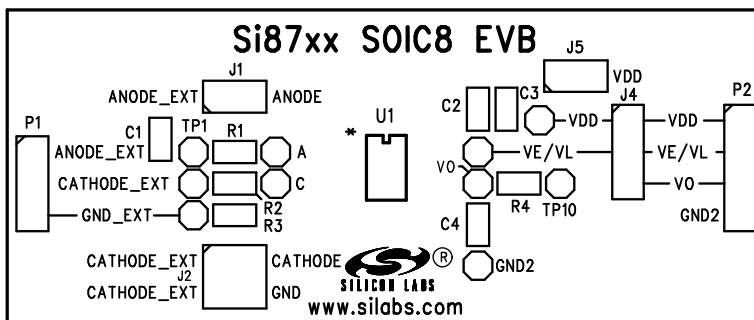

Figure 7. Si87xx SOIC8 Evaluation Board Silkscreen

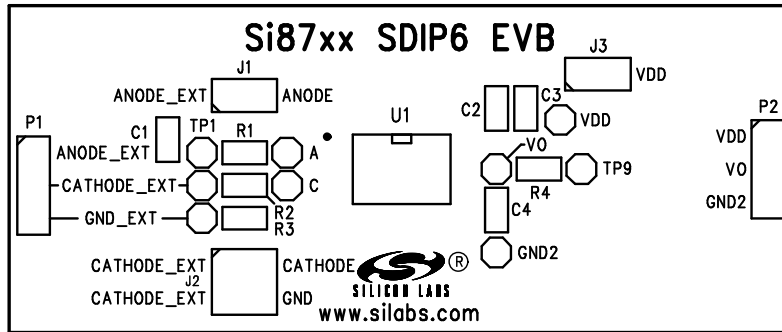

Figure 8. Si87xx SDIP6 Evaluation Board Silkscreen

5. Si871x Evaluation Board Schematics

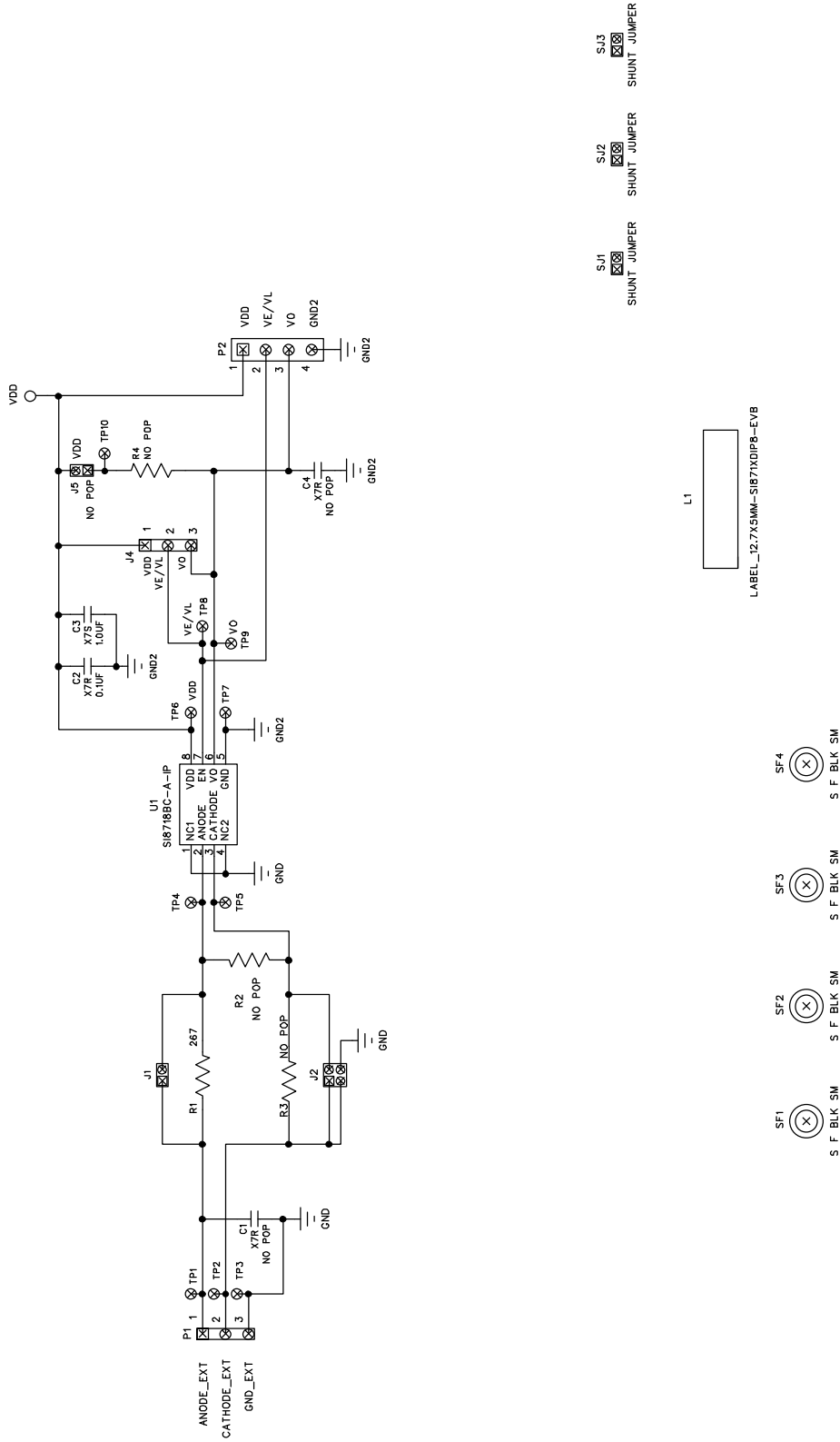

Figure 9. Si871x DIP8 Evaluation Board Schematic

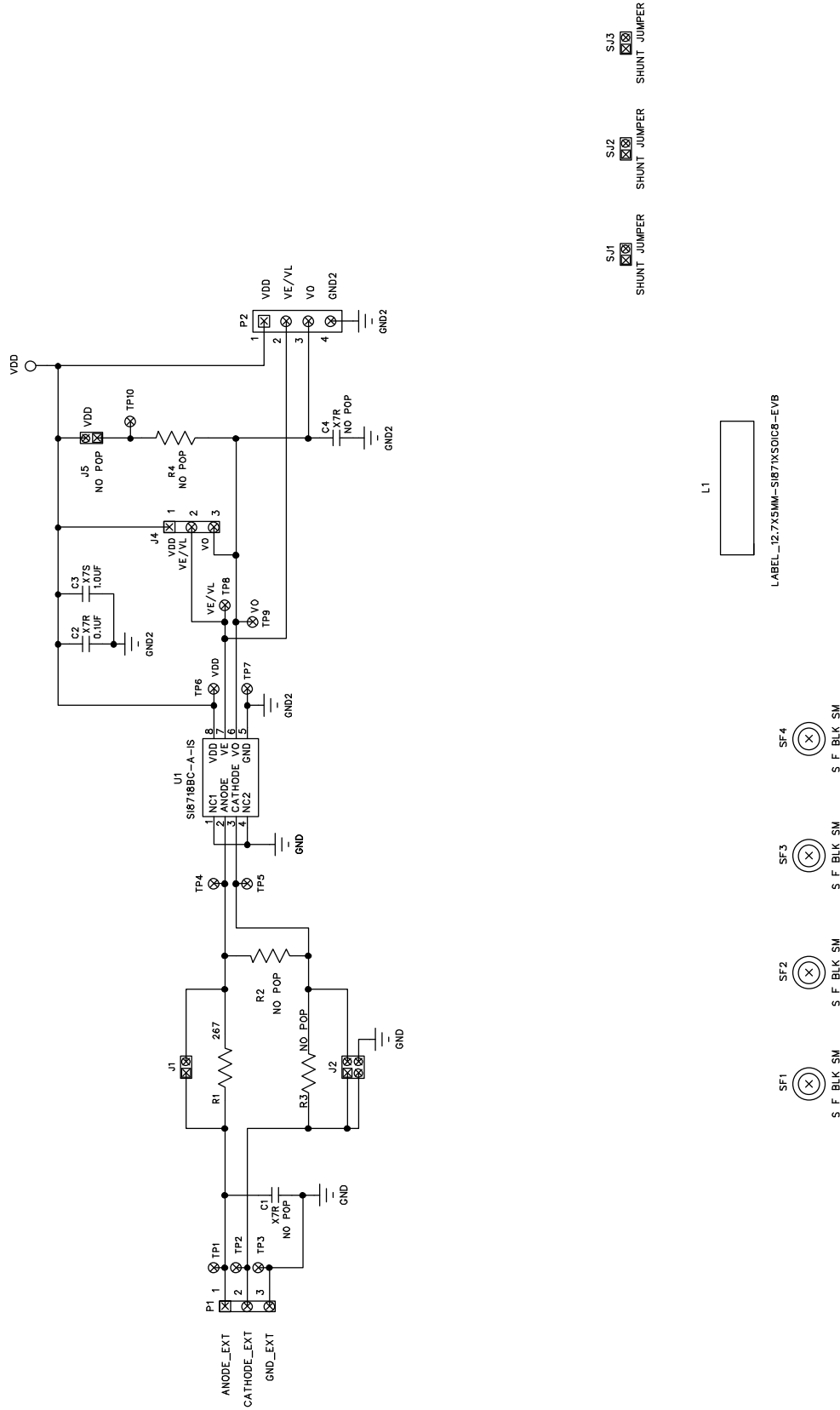
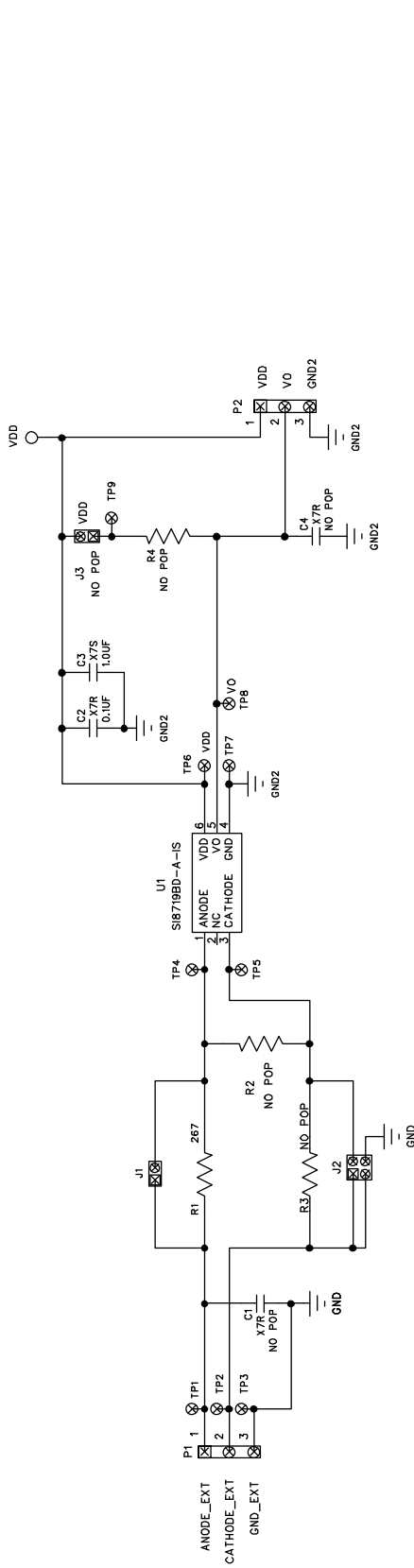

Figure 10. Si871x SOIC8 Evaluation Board Schematic



S/J1 SHUNT JUMPER
 S/J2 SHUNT JUMPER
 S/J3 SHUNT JUMPER

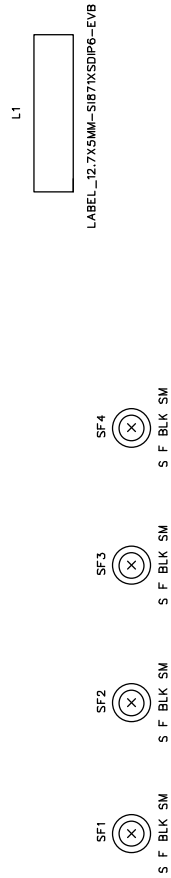

Figure 11. Si871x SDIP6 Evaluation Board Schematic

Si871x-EVB

6. Bill of Materials

Table 1. Si871x DIP8 Evaluation Board Bill of Materials

Item	Qty	Ref	Part #	Supplier	Description	Value
1	1	C2	311-1140-2-ND	Digikey	Cap, 0.1 μ F, X7R, Ceramic, 50 V, 0805, \pm 10%, or equivalent RoHS	0.1 μ F
2	1	C3	445-5205-1-ND	Digikey	Cap, 1.0 μ F, X7S, Ceramic, 805, 100 V, \pm 10%, RoHS	1.0 μ F
3	2	C1, C4	CAP 0805	Digikey	Cap, No Pop, 0805, or equivalent, RoHS	No Pop
4	1	J1	S1011E-02-ND	Digikey	Stake Header, 1x2, 0.1"CTR, Gold, or equivalent, RoHS	1x2 Header
5	1	J5	No Pop	Digikey	Stake Header, 1x2, 0.1"CTR, Gold, or eq, RoHS	No Pop
6	2	J4, P1	S1011E-03-ND	Digikey	Stake Header, 1x3, 0.1"ctr, or equivalent, RoHS	HDR1x3
7	1	P2	S1011E-04-ND	Digikey	Stake Header, 1x4, 0.1"ctrs, or equivalent, RoHS	HDR1x4
8	1	J2	S2011E-02-ND	Digikey	Stake Header, 2X2, 0.1"ctr, Gold, or equivalent, RoHS	2x2 Header
9	1	L1	M71-5-423	Brady	Label, Permanent Polyester, Thermal Transfer Print, Brady Material B423 or equivalent 12.70 x 5.08mm, Text 'SI871xDIP8-EVB'	SI871xDIP8-EVB
10	1	R1	311-267CRCT-ND	Digikey	Res, 267 Ω , SMT, 0805, 1/8 W, \pm 1%, or equivalent, RoHS	267
11	3	R2-4	No Pop	Digikey	Res, No Pop, SMT, 0805, or equivalent, RoHS	No Pop
12	3	SJ1-3	S9001-ND	Digikey	Conn, Jumper Shorting, Tin, or equivalent, RoHS. (insert after test)	Shunt Jumper
13	1	U1	SI8718BC-A-IP	Silicon Labs	Isolator, 3.75 kV Emulator Input, DIP8-GW, RoHS	SI8718BC-A-IP
14	4	SF1-4	SJ5744-0-ND	Digikey	Bumpon Protective, Bumper, Silicone, or equivalent, RoHS	S F BLK SM
15	10	TP1-10	5002K-ND	Digikey	Test Point, PC Compact, 0.63"D White, or equivalent, RoHS	5002

Table 2. Si871x SOIC8 Evaluation Board Bill of Materials

Item	Qty	Ref	Part #	Supplier	Description	Value
1	1	C2	311-1140-2-ND	Digikey	Cap, 0.1 μ F, X7R, Ceramic, 50 V, 0805, \pm 10%, or equivalent, RoHS	0.1 μ F
2	1	C3	445-5205-1-ND	Digikey	Cap, 1.0 μ F, X7S, Ceramic, 805, 100 V, \pm 10%, RoHS	1.0 μ F
3	2	C1, C4	CAP 0805	Digikey	Cap, No Pop, 0805, or equivalent, RoHS	No Pop
4	1	J1	S1011E-02-ND	Digikey	Stake Header, 1x2, 0.1" Ctr, Gold, or equivalent, RoHS	1x2 Header
5	2	J4, P1	S1011E-03-ND	Digikey	Stake Header, 1x3, 0.1" Ctr, or equivalent, RoHS	HDR1x3
6	1	P2	S1011E-04-ND	Digikey	Stake Header, 1x4, 0.1" Ctrs, or equivalent, RoHS	HDR1x4
7	1	J5	No Pop	Digikey	Stake Header, 1x2, 0.1" Ctr, Gold, or equivalent, RoHS	No Pop
8	1	J2	S2011E-02-ND	Digikey	Stake Header, 2x2, 0.1" Ctr, Gold, or equivalent, RoHS	2x2 Header
9	1	L1	M71-5-423	Brady	Label, Permanent Polyester, Thermal Transfer Print, Brady Material B423 or equivalent 12.70 x 5.08mm, Text 'SI871xSOIC8-EVB'	SI871xSOIC8-EVB
10	1	R1	311-267CRCT-ND	Digikey	Res, 267 Ω , SMT, 0805, 1/8 W, \pm 1%, or equivalent, RoHS	267
11	3	R2-4	No Pop	Digikey	Res, No Pop, SMT, 0805, or equivalent, RoHS	No Pop
12	3	SJ1-3	S9001-ND	Digikey	Conn, Jumper Shorting, Tin, or equivalent, RoHS. (insert after test)	Shunt Jumper
13	1	U1	SI8718BC-A-IS	Silicon Labs	3.75 kV LED Emulator Input, Isolator, SOIC-8, RoHS	SI8718BC-A-IS
14	4	SF1-4	SJ5744-0-ND	Digikey	Bumpon Protective, Bumper, Silicone, or equivalent, RoHS	S F BLK SM
15	10	TP1-10	5002K-ND	Digikey	Test Point, PC Compact, 0.63"D white, or equivalent, RoHS	5002

Si871x-EVB

Table 3. Si871x SDIP6 Evaluation Board Bill of Materials

Item	Qty	Ref	Part #	Supplier	Description	Value
1	1	C2	311-1140-2-ND	Digikey	Cap, 0.1 μ F, X7R, Ceramic, 50 V, 0805, \pm 10%, or equivalent, RoHS	0.1 μ F
2	1	C3	445-5205-1-ND	Digikey	Cap, 1.0 μ F, X7S, Ceramic, 805, 100 V, \pm 10%, RoHS	1.0 μ F
3	2	C1, C4	CAP 0805	Digikey	Cap, No Pop, 0805, or equivalent, RoHS	No Pop
4	1	J1	S1011E-02-ND	Digikey	Stake Header, 1x2, 0.1" Ctr, Gold, or equivalent, RoHS	1x2 Header
5	2	P1-2	S1011E-03-ND	Digikey	Stake Header, 1X3, 0.1" CTR, OR EQ, RoHS	HDR1X3
6	1	J3	No Pop	Digikey	Stake Header, 1x2, 0.1" Ctr, Gold, or equivalent, RoHS	No Pop
7	1	J2	S2011E-02-ND	Digikey	Stake Header, 2x2, 0.1" Ctr, Gold, or equivalent, RoHS	2x2 Header
8	1	L1	M71-5-423	Brady	Label, Permanent Polyester, Thermal Transfer Print, Brady Material B423 or equivalent 12.70 x 5.08mm, Text 'SI871xSDIP6-EVB'	SI871xSDIP6-EVB
9	1	R1	311-267CRCT-ND	Digikey	Res, 267 Ω , SMT, 0805, 1/8 W, \pm 1%, or equivalent, RoHS	267
10	3	R2-4	No Pop	Digikey	Res, No Pop, SMT, 0805, or equivalent, RoHS	No Pop
11	3	SJ1-3	S9001-ND	Digikey	Conn, Jumper Shorting, Tin, or equivalent, RoHS. (insert after test)	Shunt Jumper
12	1	U1	SI8719BD-A-IS	Silicon Labs	Isolator, 5 kV emulator Input, SDIP6, RoHS	SI8719BD-A-IS
13	4	SF1-4	SJ5744-0-ND	Digikey	Bump Protective, Bumper, Silicone, or equivalent, RoHS	S F BLK SM
14	9	TP1-9	5002K-ND	Digikey	Test Point, PC Compact, 0.63"D White, or equivalent, RoHS	5002

7. Ordering Guide

Table 4. Si871x Evaluation Board Ordering Guide

Ordering Part Number (OPN)	Description
Si871xDIP8-KIT	Si871x Isolator Evaluation Board Kit featuring DIP8 Package
Si871xSOIC8-KIT	Si871x Isolator Evaluation Board Kit featuring SOIC8 Package
Si871xSDIP6-KIT	Si871x Isolator Evaluation Board Kit featuring SDIP6 Package

Si871x-EVB

CONTACT INFORMATION

Silicon Laboratories Inc.

400 West Cesar Chavez

Austin, TX 78701

Tel: 1+(512) 416-8500

Fax: 1+(512) 416-9669

Toll Free: 1+(877) 444-3032

Please visit the Silicon Labs Technical Support web page:

<https://www.siliconlabs.com/support/pages/contacttechnicalsupport.aspx>

and register to submit a technical support request.

Patent Notice

Silicon Labs invests in research and development to help our customers differentiate in the market with innovative low-power, small size, analog-intensive mixed-signal solutions. Silicon Labs' extensive patent portfolio is a testament to our unique approach and world-class engineering team.

The information in this document is believed to be accurate in all respects at the time of publication but is subject to change without notice. Silicon Laboratories assumes no responsibility for errors and omissions, and disclaims responsibility for any consequences resulting from the use of information included herein. Additionally, Silicon Laboratories assumes no responsibility for the functioning of undescribed features or parameters. Silicon Laboratories reserves the right to make changes without further notice. Silicon Laboratories makes no warranty, representation or guarantee regarding the suitability of its products for any particular purpose, nor does Silicon Laboratories assume any liability arising out of the application or use of any product or circuit, and specifically disclaims any and all liability, including without limitation consequential or incidental damages. Silicon Laboratories products are not designed, intended, or authorized for use in applications intended to support or sustain life, or for any other application in which the failure of the Silicon Laboratories product could create a situation where personal injury or death may occur. Should Buyer purchase or use Silicon Laboratories products for any such unintended or unauthorized application, Buyer shall indemnify and hold Silicon Laboratories harmless against all claims and damages.

Silicon Laboratories and Silicon Labs are trademarks of Silicon Laboratories Inc.

Other products or brandnames mentioned herein are trademarks or registered trademarks of their respective holders.

Компания «Океан Электроники» предлагает заключение долгосрочных отношений при поставках импортных электронных компонентов на взаимовыгодных условиях!

Наши преимущества:

- Поставка оригинальных импортных электронных компонентов напрямую с производств Америки, Европы и Азии, а так же с крупнейших складов мира;
- Широкая линейка поставок активных и пассивных импортных электронных компонентов (более 30 млн. наименований);
- Поставка сложных, дефицитных, либо снятых с производства позиций;
- Оперативные сроки поставки под заказ (от 5 рабочих дней);
- Экспресс доставка в любую точку России;
- Помощь Конструкторского Отдела и консультации квалифицированных инженеров;
- Техническая поддержка проекта, помощь в подборе аналогов, поставка прототипов;
- Поставка электронных компонентов под контролем ВП;
- Система менеджмента качества сертифицирована по Международному стандарту ISO 9001;
- При необходимости вся продукция военного и аэрокосмического назначения проходит испытания и сертификацию в лаборатории (по согласованию с заказчиком);
- Поставка специализированных компонентов военного и аэрокосмического уровня качества (Xilinx, Altera, Analog Devices, Intersil, Interpoint, Microsemi, Actel, Aeroflex, Peregrine, VPT, Syfer, Eurofarad, Texas Instruments, MS Kennedy, Miteq, Cobham, E2V, MA-COM, Hittite, Mini-Circuits, General Dynamics и др.);

Компания «Океан Электроники» является официальным дистрибьютором и эксклюзивным представителем в России одного из крупнейших производителей разъемов военного и аэрокосмического назначения «JONHON», а так же официальным дистрибьютором и эксклюзивным представителем в России производителя высокотехнологичных и надежных решений для передачи СВЧ сигналов «FORSTAR».



JONHON

«JONHON» (основан в 1970 г.)

Разъемы специального, военного и аэрокосмического назначения:

(Применяются в военной, авиационной, аэрокосмической, морской, железнодорожной, горно- и нефтедобывающей отраслях промышленности)

«FORSTAR» (основан в 1998 г.)

ВЧ соединители, коаксиальные кабели, кабельные сборки и микроволновые компоненты:

(Применяются в телекоммуникациях гражданского и специального назначения, в средствах связи, РЛС, а так же военной, авиационной и аэрокосмической отраслях промышленности).



Телефон: 8 (812) 309-75-97 (многоканальный)

Факс: 8 (812) 320-03-32

Электронная почта: ocean@oceanchips.ru

Web: <http://oceanchips.ru/>

Адрес: 198099, г. Санкт-Петербург, ул. Калинина, д. 2, корп. 4, лит. А