



±16 Gauss, Ultra Small, Low Noise 3-axis Magnetic Sensor

MMC3416xPJ

FEATURES

- Fully integrated 3-axis magnetic sensor and electronic circuits requiring fewer external components
- Superior Dynamic Range and Accuracy:
 - ✓ ±16 G FSR with 16/14 bits operation
 - ✓ 0.5 mG/2 mG per LSB resolution in 16/14 bits operation mode
 - ✓ 1.5 mG total RMS noise
 - ✓ Enables heading accuracy of ±1°
- Max output data rate of 800 Hz (12 bits mode)
- Ultra Small Low profile package
1.6x1.6x0.6 mm
- SET/RESET function
 - ✓ Allows for elimination of temperature variation induced offset error (Null field output)
 - ✓ Clears the sensors of residual magnetization resulting from strong external fields
- On-chip sensitivity compensation
- Low power consumption (140 µA @ 7 Hz)
- 1 µA (max) power down function
- I²C Slave, FAST (≤400 KHz) mode
- 1.62 V~3.6 V wide power supply operation supported, 1.8 V I/O compatibility.
- RoHS compliant

APPLICATIONS

- Electronic Compass & GPS Navigation
- Position Sensing

DESCRIPTION

The MMC3416xPJ is a complete 3-axis magnetic sensor with on-chip signal processing and integrated I²C bus. The device can be connected directly to a microprocessor, eliminating the need for A/D converters or timing resources. It can measure magnetic fields within the full scale range of ±16 Gauss (G), with 0.5 mG/2 mG per LSB resolution for 16/14 bits operation mode and 1.5 mG total RMS

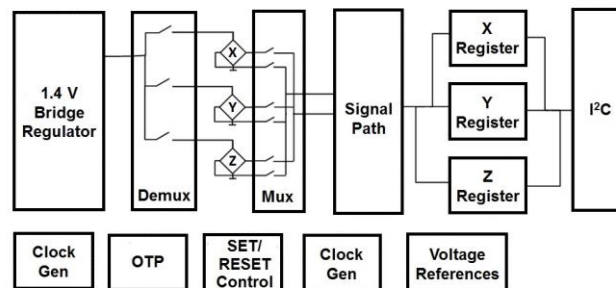

FUNCTIONAL BLOCK DIAGRAM

noise level, enabling heading accuracy of 1° in electronic compass applications. Contact MEMSIC for access to advanced calibration and tilt-compensation algorithms.

An integrated SET/RESET function provides for the elimination of error due to Null Field output change with temperature. In addition it clears the sensors of any residual magnetic polarization resulting from exposure to strong external magnets. The SET/RESET function can be performed for each measurement or periodically as the specific application requires.

The MMC3416xPJ is packaged in an ultra small low profile BGA package (1.6 x 1.6 x 0.6 mm,) and with an operating temperature range from -40 °C to +85 °C.

The MMC3416xPJ provides an I²C digital output with 400 KHz, fast mode operation.

Information furnished by MEMSIC is believed to be accurate and reliable. However, no responsibility is assumed by MEMSIC for its use, or for any infringements of patents or other rights of third parties which may result from its use. No license is granted by implication or otherwise under any patent or patent rights of MEMSIC.

©MEMSIC, Inc.
One Technology Drive, Suite 325, Andover, MA01810, USA
Tel: +1 978 738 0900 Fax: +1 978 738 0196
www.memsic.com

SPECIFICATIONS (Measurements @ 25 °C, unless otherwise noted; $V_{DA} = V_{DD} = 1.8$ V unless otherwise specified)

Parameter	Conditions	Min	Typ	Max	Units
Field Range (Each Axis)	Total applied field		±16		G
Supply Voltage	V_{DA}	1.62 ¹	1.8	3.6	V
	V_{DD} (I ² C interface)	1.62 ¹	1.8	3.6	V
Supply Voltage Rise Time				5.0	mS
Supply Current ² (7measurements/second)	BW[1:0]=00, 16 bits mode		140		µA
	BW[1:0]=01, 16 bits mode		70		µA
	BW[1:0]=10, 14 bits mode		35		µA
	BW[1:0]=11, 12 bits mode		18		µA
Power Down Current				1.0	µA
Operating Temperature		-40		85	°C
Storage Temperature		-55		125	°C
Linearity Error (Best fit straight line)	FS=±16 G $H_{applied} = ±10$ G		0.25		%FS
Hysteresis	3 sweeps across ±16 G		0.1		%FS
Repeatability Error	3 sweeps across ±16 G		0.1		%FS
Alignment Error			±1.0	±3.0	degrees
Transverse Sensitivity			±2.0	±5.0	%
Total RMS Noise	BW[1:0]=00, 16 bits mode		1.5		mG
	BW[1:0]=01, 16 bits mode		2.0		mG
	BW[1:0]=10, 14 bits mode		4.0		mG
	BW[1:0]=11, 12 bits mode		6.0		mG
Output resolution			16/14/12		bits
Max Output data rate	BW[1:0]=00, 16 bits mode		125		Hz
	BW[1:0]=01, 16 bits mode		250		Hz
	BW[1:0]=10, 14 bits mode		450		Hz
	BW[1:0]=11, 12 bits mode		800		Hz
Heading accuracy ³			±1.0		degrees
Sensitivity	±16 G	-10		+10	%
	16 bits mode		2048		counts/G
	14 bits mode		512		counts/G
	12 bits mode		128		counts/G
Sensitivity Change Over Temperature	-40~85°C Delta from 25°C ±16 G		±3		%
Null Field Output			±0.1		G
	16 bits mode		32768		counts
	14 bits mode		8192		counts
	12 bits mode		2048		counts
Null Field Output Change Over Temperature using SET/RESET	-40~85 °C Delta from 25 °C		±5		mG
Disturbing Field ⁴			25		G
Maximum Exposed Field				10000	G
SET/RESET Repeatability ⁵			3		mG

¹ 1.62 V is the minimum operation voltage, or V_{DA} / V_{DD} should not be lower than 1.62 V.

² Supply current is proportional to how many measurements performed per second, for example, at one measurement per second, the power consumption will be 140 µA/7=20 µA.

³ MEMSIC product enables users to utilize heading accuracy to be 1.0 degree typical when using MEMSIC's proprietary software or algorithm

⁴ This is the magnitude of external field that can be tolerated without changing the sensor characteristics. If the disturbing field is exceeded, a SET/RESET operation is required to restore proper sensor operation.

⁵ Perform SET/RESET alternately. SET repeatability is defined as the difference in measurement between multiple SET events. RESET repeatability is defined similarly.

I²C INTERFACE I/O CHARACTERISTICS (V_{DD}=1.8 V)

Parameter	Symbol	Test Condition	Min.	Typ.	Max.	Unit
Logic Input Low Level	V _{IL}		-0.5		0.3* V _{DD}	V
Logic Input High Level	V _{IH}		0.7*V _{DD}		V _{DD}	V
Hysteresis of Schmitt input	V _{hys}		0.2			V
Logic Output Low Level	V _{OL}				0.4	V
Input Leakage Current	I _i	0.1V _{DD} <V _{in} <0.9V _{DD}	-10		10	μA
SCL Clock Frequency	f _{SCL}		0		400	kHz
START Hold Time	t _{HD,STA}		0.6			μS
START Setup Time	t _{SU,STA}		0.6			μS
LOW period of SCL	t _{LOW}		1.3			μS
HIGH period of SCL	t _{HIGH}		0.6			μS
Data Hold Time	t _{HD,DAT}		0		0.9	μS
Data Setup Time	t _{SU,DAT}		0.1			μS
Rise Time	t _r	From V _{IL} to V _{IH}			0.3	μS
Fall Time	t _f	From V _{IH} to V _{IL}			0.3	μS
Bus Free Time Between STOP and START	t _{BUF}		1.3			μS
STOP Setup Time	t _{SU,STO}		0.6			μS

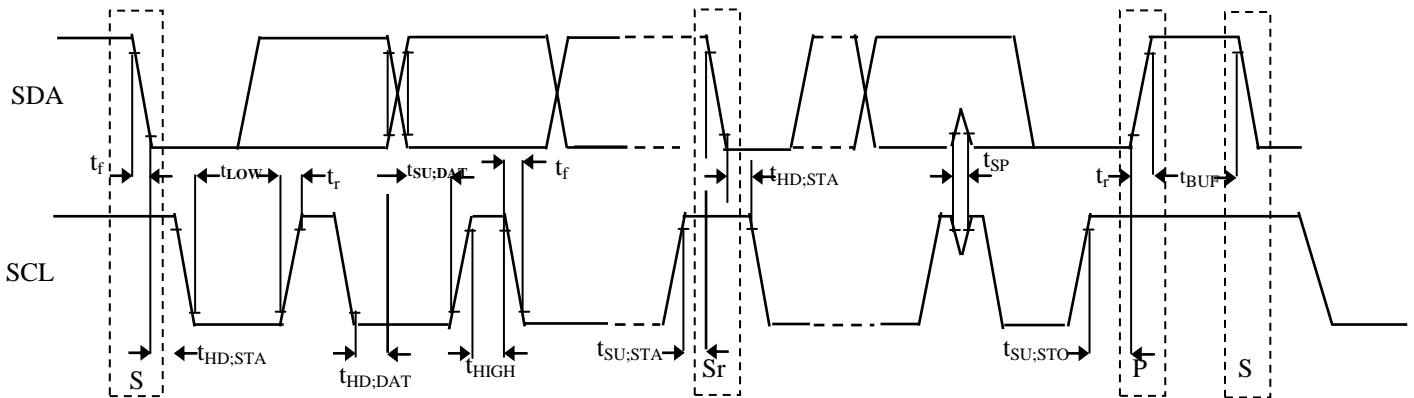

Timing Definition

ABSOLUTE MAXIMUM RATINGS*

Supply Voltage (V_{DD})-0.5 to +3.6 V
 Storage Temperature-55 °C to +125 °C
 Maximum Exposed Field10000 G

*Stresses above those listed under Absolute Maximum Ratings may cause permanent damage to the device. This is a stress rating only; the functional operation of the device at these or any other conditions above those indicated in the operational sections of this specification is not implied. Exposure to absolute maximum rating conditions for extended periods may affect the device's reliability.

Pin Description: BGA Package

Pin	Name	Description	I/O
1	TEST	Factory Use Only, Leave Open/Not connected	NC
2	NC	Not Connected	NC
3	SCL	Serial Clock Line for I ² C bus	I
4	SDA	Serial Data Line for I ² C bus	I/O
5	V _{pp}	Factory Use Only, Leave Open	NC
6	V _{DD}	Power Supply for I ² C bus	P
7	NC	Not Connected	NC
8	CAP	Connect to External Capacitor	I
9	NC	Not Connected	NC
10	NC	Not Connected	NC
11	V _{SA}	Connect to Ground	P
12	V _{DA}	Power Supply	P

All parts are shipped in tape and reel packaging with 9000pcs per 13" reel or 3000pcs per 7" reel.

Caution: ESD (electrostatic discharge) sensitive device.

Ordering Guide:

MMC3416xPJ

Package type:

Code	Type
J	BGA12 RoHS compliant

Performance Grade:

Code	Performance Grade
P	Temp compensated

Address code: 0~7

Code	7 bit I ² C Address
0	0110000b
1	0110001b
2	0110010b
3	0110011b
4	0110100b
5	0110101b
6	0110110b
7	0110111b

Marking illustration:

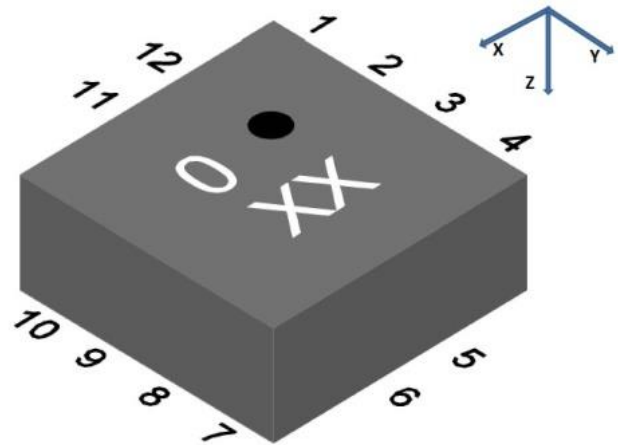

Note: Coordinates shown above indicate polarity after a SET operation.

Number	Part number
0	MMC34160PJ
1	MMC34161PJ
2	MMC34162PJ
3	MMC34163PJ
4	MMC34164PJ
5	MMC34165PJ
6	MMC34166PJ
7	MMC34167PJ

"Number" represents the character of the 1st line in the marking, the black dot indicates pin one (1). The 2nd line represents Lot Number.

THEORY OF OPERATION

The Anisotropic Magneto-Resistive (AMR) sensors are special resistors made of permalloy thin film deposited on a silicon wafer. During manufacturing, a strong magnetic field is applied to the film to orient its magnetic domains in the same direction, establishing a magnetization vector. Subsequently, an external magnetic field applied perpendicularly to the sides of the film causes the magnetization to rotate and change angle. This effect causes the film's resistance to vary with the intensity of the applied magnetic field. The MEMSIC AMR sensor is incorporated into a Wheatstone bridge configuration to maximize Signal to Noise ratio. A change in magnetic field produces a proportional change in differential voltage across the Wheatstone bridge.

However, the influence of a strong magnetic field (more than 25 G) in any direction could upset, or flip, the polarity of the film, thus changing the sensor characteristics. A strong restoring magnetic field must be applied momentarily to restore, or set, the sensor characteristics. The MEMSIC magnetic sensor has an on-chip magnetically coupled strap: a SET/RESET strap pulsed with a high current, to provide the restoring magnetic field.

PIN DESCRIPTIONS

V_{DA} – This is the supply input for the circuits and the magnetic sensor. The DC voltage should be between 1.62 and 3.6 volts. A 1uF by-pass capacitor is strongly recommended.

VSA – This is the ground pin for the magnetic sensor.

SDA – This pin is the I²C serial data line, and operates in FAST (400 KHz) mode.

SCL – This pin is the I²C serial clock line, and operates in FAST (400 KHz) mode.

V_{DD} – This is the power supply input for the I²C bus, and is 1.8 V compatible (1.62 V to 3.6 V). V_{DD} is independent of V_{DA}.

TEST – Factory use only, Leave Open/Not connected

CAP – Connect a 4.7 μF low ESR (typically smaller than 0.2 ohm) ceramic capacitor.

V_{pp} – Factory use only, Leave Open

EXTERNAL CIRCUITRY CONNECTION

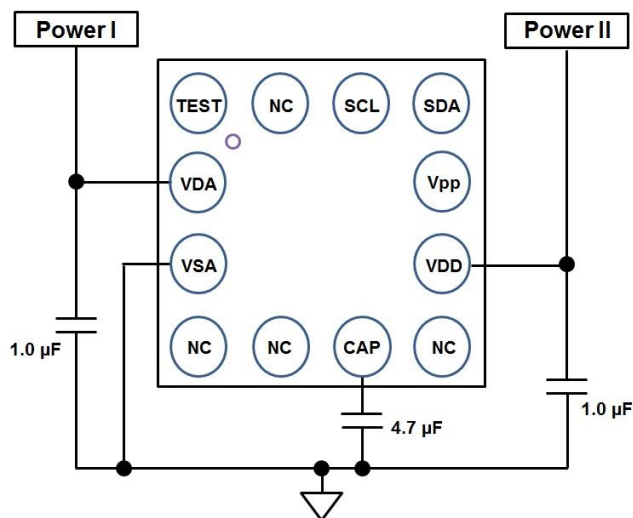

(Top View)

HARDWARE DESIGN CONSIDERATION

- ✓ Provide adequate separation distance to devices that contain permanent magnets or generate magnetic fields (IE speakers, coils, inductors...) The combined magnetic field to be measured and interference magnetic field should be less than the full scale range of the MMC3416xPJ (±16 G).
- ✓ Provide adequate separation distance to current carrying traces. Do not route current carrying traces under the sensor or on the other side of the PCB opposite the device.
- ✓ Do not cover the sensor with magnetized material or material that may become magnetized, (IE, shield box, LCD, battery, iron bearing material...).

- ✓ Do not place the device opposite magnetized material or material that may become magnetized located on the other side of the PCB.

Please refer to MEMSIC application note: AN-200-20-0001 (MEMSIC Magnetic Sensor Hardware Design Layout Guideline for Electronic Device).

POWER CONSUMPTION

The power consumed by the device is proportional to the number of measurements taken per second. For example, when BW<1:0>=00, that is, 16-bit mode with 7.92 mS per measurement, MMC3416xPJ consumes 140 μA (typical) at 1.8 V with 7 measurements per second. If only 2 measurements are performed per second, the current will be 140*2/7=40 μA.

I²C INTERFACE DESCRIPTION

A slave mode I²C circuit has been implemented into the MEMSIC magnetic sensor as a standard interface for customer applications. The A/D converter and MCU functionality have been added to the MEMSIC sensor, thereby increasing ease-of-use, and lowering power consumption, footprint and total solution cost.

The I²C (or Inter IC bus) is an industry standard bi-directional two-wire interface bus. A master I²C device can operate READ/WRITE controls to an unlimited number of devices by device addressing. The MEMSIC magnetic sensor operates only in a slave mode, i.e. only responding to calls by a master device.

I²C BUS CHARACTERISTICS

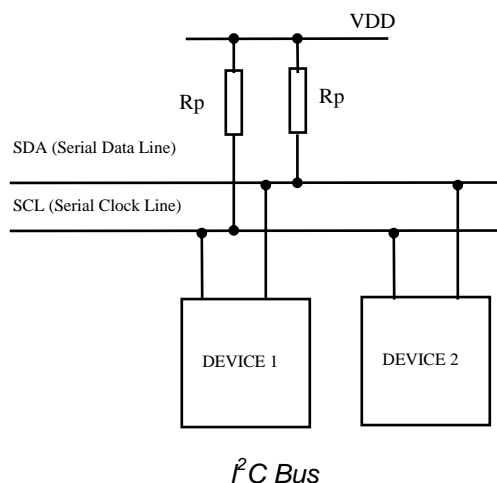

The two wires in the I²C bus are called SDA (serial data line) and SCL (serial clock line). In order for a data transfer to start, the bus has to be free, which is defined by both wires in a HIGH output state. Due to the open-drain/pull-up resistor structure and wired Boolean “AND” operation, any device on the bus can pull lines low and overwrite a HIGH signal. The data

on the SDA line has to be stable during the HIGH period of the SCL line. In other words, valid data can only change when the SCL line is LOW.

Note: Rp selection guide: 4.7 Kohm for a short I²C bus length (less than 10 cm), and 10Kohm for a bus length less than 5 cm.

REGISTER MAP

Register Name	Address	Description
Xout Low	00H	Xout LSB
Xout High	01H	Xout MSB
Yout Low	02H	Yout LSB
Yout High	03H	Yout MSB
Zout Low	04H	Zout LSB
Zout High	05H	Zout MSB
Status	06H	Device status
Internal control 0	07H	Control register 0
Internal control 1	08H	Control register 1
R0	1BH	Factor used register
R1	1CH	Factory used register
R2	1DH	Factory used register
R3	1EH	Factory used register
R4	1FH	Factory used register
Product ID 1	20H	Product ID

Register Details

Xout High, Xout Low

Xout Low	7	6	5	4	3	2	1	0
Addr: 00H	Xout[7:0]							
Mode	R							

Xout High	7	6	5	4	3	2	1	0
Addr: 01H	Xout[15:8]							
Mode	R							

X-axis output, unsigned format, the 2 LSB of Xout Low will be fixed as "0" when in 12 bit mode, the 2 LSB of Xout Low will be fixed as "0" when in 14 bit mode.

Yout High, Yout Low

Yout Low	7	6	5	4	3	2	1	0
Addr: 02H	Yout[7:0]							
Mode	R							

Yout High	7	6	5	4	3	2	1	0
Addr: 03H	Yout[15:8]							
Mode	R							

Y-axis output, unsigned format, the 2 LSB of Yout Low will be fixed as "0" when in 12 bit mode, the 2 LSB of Yout Low will be fixed as "0" when in 14 bit mode.

Zout High, Zout Low

Zout Low	7	6	5	4	3	2	1	0
Addr: 04H	Zout[7:0]							
Mode	R							

Zout High	7	6	5	4	3	2	1	0
Addr: 05H	Zout[15:7]							
Mode	R							

Z-axis output, unsigned format, the 2 LSB of Zout Low will be fixed as "0" when in 12 bit mode, the 2 LSB of Zout Low will be fixed as "0" when in 14 bit mode.

Status

Device Status	7	6	5	4	3	2	1	0
Addr: 06H	Reserved				ST_XYZ_OK	Rd_Done	Pump On	Meas Done
Reset Value	0	0	0	0	0	0	0	0
Mode	R							

Bit Name	Description
Meas Done	Indicates measurement event is completed. This bit should be checked before reading the output
Pump On	Indicates the charge pump status, after Refill Cap command, the charge pump will start running, and this bit will stays high, it will be reset low after the cap reaches its target voltage and the charge pump is shut off.
Rd_Done	Indicates the chip was able to successfully read its memory.
ST_XYZ_OK	Indicate selftest OK once this bit is "1".

Internal Control 0

Control Register 0	7	6	5	4	3	2	1	0
Addr: 07H	Refill Cap	RESET	SET	No Boost	CM Freq1	CM Freq0	Cont Mode On	TM
Reset Value	0	0	0	0	0	0	0	0
Mode	W	W	W	W	W	W	W	W

Bit Name	Description															
TM	Take measurement, set '1' will initiate measurement.															
Cont Mode On	When set to a 1 this enables the Continuous Measurement Mode. The chip will periodically take measurements of the magnetic field; the frequency of these measurements is determined by bits CM Freq<1:0>.															
CM Freq0 & CM Freq1	These bits determine how often the chip will take measurements in Continuous Measurement Mode.															
	<table border="1"> <thead> <tr> <th>CM Freq1</th> <th>CM Freq0</th> <th>Frequency</th> </tr> </thead> <tbody> <tr> <td>0</td> <td>0</td> <td>1.5 Hz</td> </tr> <tr> <td>0</td> <td>1</td> <td>13 Hz</td> </tr> <tr> <td>1</td> <td>0</td> <td>25 Hz</td> </tr> <tr> <td>1</td> <td>1</td> <td>50 Hz</td> </tr> </tbody> </table>	CM Freq1	CM Freq0	Frequency	0	0	1.5 Hz	0	1	13 Hz	1	0	25 Hz	1	1	50 Hz
	CM Freq1	CM Freq0	Frequency													
	0	0	1.5 Hz													
	0	1	13 Hz													
1	0	25 Hz														
1	1	50 Hz														
No Boost	Setting this bit high will disable the charge pump and cause the storage capacitor to be charged off VDD.															
SET	Writing "1" will set the sensor by passing a large current through Set/Reset Coil															
RESET	Writing "1" will reset the sensor by passing a large current through Set/Reset Coil in a reversed direction															
Refill Cap	Writing "1" will recharge the capacitor at CAP pin, it is requested to be issued before SET/RESET command.															

Internal Control 1

Control Register 1	7	6	5	4	3	2	1	0
Addr: 08H	SW_RST	Temp_tst	ST_XYZ	Z-inhibit	Y-inhibit	X-inhibit	BW1	BW0
Reset Value	0	0	0	0	0	0	0	0
Mode	W	W	W	W	W	W	W	W

Bit Name	Description																				
BW0 & BW1	Output resolution																				
	<table border="1"> <thead> <tr> <th>BW1</th> <th>BW0</th> <th>Output Resolution</th> <th>Measurement Time</th> </tr> </thead> <tbody> <tr> <td>0</td> <td>0</td> <td>16 bits</td> <td>7.92 mS</td> </tr> <tr> <td>0</td> <td>1</td> <td>16 bits</td> <td>4.08 mS</td> </tr> <tr> <td>1</td> <td>0</td> <td>14 bits</td> <td>2.16 mS</td> </tr> <tr> <td>1</td> <td>1</td> <td>12 bits</td> <td>1.20 mS</td> </tr> </tbody> </table>	BW1	BW0	Output Resolution	Measurement Time	0	0	16 bits	7.92 mS	0	1	16 bits	4.08 mS	1	0	14 bits	2.16 mS	1	1	12 bits	1.20 mS
	BW1	BW0	Output Resolution	Measurement Time																	
	0	0	16 bits	7.92 mS																	
	0	1	16 bits	4.08 mS																	
1	0	14 bits	2.16 mS																		
1	1	12 bits	1.20 mS																		
Note: X/Y/Z channel measurements are taken sequentially. Delay Time among those measurements is 1/3 of the Measurement Time defined in the table.																					
X-inhibit	Factory-use Register																				
Y-inhibit																					
Z-inhibit																					
ST_XYZ	Selftest check, write "1" to this bit and execute a TM command, after TM is completed the result can be read as bit ST_XYZ_OK.																				
Temp_tst	Factory-use Register																				
SW_RST	Writing "1" will cause the part to reset, similar to power-up. It will clear all registers and also re-read OTP as part of its startup routine.																				

Product ID 1

Product ID 1	7	6	5	4	3	2	1	0
Addr: 20H	Product ID1[7:0]							
Reset Value	0	0	0	0	0	1	1	0
Mode	R	R	R	R	R	R	R	R

DATA TRANSFER

A data transfer is started with a "START" condition and ended with a "STOP" condition. A "START" condition is defined by a HIGH to LOW transition on the SDA line while SCL line is HIGH. A "STOP" condition is defined by a LOW to HIGH transition on the SDA line while the SCL line is held HIGH. All data transfer in I²C system are 8-bits long. Each byte has to be followed by an acknowledge bit. Each data transfer involves a total of 9 clock cycles. Data is transferred starting with the most significant bit (MSB).

After a START condition, the master device calls a specific slave device by sending its 7-bit address with the 8th bit (LSB) indicating that either a READ or WRITE operation will follow, [1] for READ and [0] for WRITE. The MEMSIC device 7-bit device address is [x110xxx] where the three LSB's are pre-programmed into the MMC3416xPJ by the factory and they are indicated on the package as shown in the previous section "Package Marking Illustration".

A total of 8 different addresses can be pre-programmed into MEMSIC device by the factory. This variation of I²C address avoids a potential address

conflict, either by ICs from other manufacturers or by other MEMSIC devices on the same bus

The initial addressing of the slave is always followed by the master writing the number of the slave register to be read or written, so this initial addressing always indicates a WRITE operation by sending [0110xxx1]. After being addressed, the MEMSIC device being called should respond by an "Acknowledge" signal by pulling SDA line LOW. Subsequent communication bytes can either be:

- the data to be written to the device register, or
- Another START condition followed by the device address indicating a READ operation [0110xxx0], and then the master reads the register data.

Multiple data bytes can be written or read to numerically sequential registers without the need of another START condition. Data transfer is terminated by a STOP condition or another START condition. Two detailed examples of communicating with the MEMSIC device are listed below for the actions of acquiring a magnetic field measurement and magnetizing the sensor.

POWER STATE

MEMSIC MR Sensor will enter power down mode automatically after data acquisition is finished.

VDA	VDD	Power State
OFF(0 V)	OFF(0V)	OFF(0 V), no power consumption
OFF(0 V)	1.62~3.6 V	OFF(0 V), power consumption is less than 1 uA.
1.62~3.6 V	OFF(0 V)	Power consumption is not predictable, not recommended state.
1.62~3.6 V	1.62~3.6 V	Normal operation mode, device will enter into power down mode automatically after data acquisition is finished

EXAMPLE MEASUREMENT

1st cycle: A START condition is established by the Master Device followed by a call to the slave address [0110xxx] with the eighth bit held low to indicate a WRITE request. Note: [xxx] is determined by factory programming and a total of 8 different addresses are available.

2nd cycle: After an acknowledge signal is received by the master device (MEMSIC device pulls SDA line low during 9th SCL pulse), the master device sends the address of Control Register 0 or [00000111] as the target register to be written. The MEMSIC device should acknowledge receipt of the address (9th SCL pulse, SCL pulled low).

3rd cycle: The Master device writes to the Internal Control Register 0 the code [00000001] (TM high) to initiate data acquisition. The MEMSIC device should send an Acknowledge and internally initiate a measurement (collect x, y and z data). A STOP condition indicates the end of the write operation.

4th cycle: The Master device sends a START command followed by the MEMSIC device's seven bit address, and finally the eighth bit set low to indicate a WRITE. An Acknowledge should be send by the MEMSIC device in response.

5th cycle: The Master device sends the MEMSIC device's Status Register [00000110] as the address to read.

6th cycle: The Master device sends a START command followed by the MEMSIC device's seven bit address, and finally the eighth bit set high to indicate a READ. An Acknowledge should be send by the MEMSIC device in response.

7th cycle: The Master device cycles the SCL line. This causes the Status Register data to appear on SDA line. Continuously read the Status Register until the

Meas Done bit (bit 0) is set to '1'. This indicates that data for the x, y, and z sensors is available to be read.

8th cycle: The Master device sends a START command followed by the MEMSIC device's seven bit address, and finally the eighth bit set low to indicate a WRITE. An Acknowledge should be send by the MEMSIC device in response.

9th cycle: The Master device sends a [00000000] (Xout LSB register address) as the register address to read.

10th cycle: The Master device calls the MEMSIC device's address with a READ (8th SCL cycle SDA line high). An Acknowledge should be send by the MEMSIC device in response.

11th cycle: Master device continues to cycle the SCL line, and each consecutive byte of data from the X, Y and Z registers should appear on the SDA line. The internal memory address pointer automatically moves to the next byte. The Master device acknowledges each. Thus:

12th cycle: LSB of X channel.

13th cycle: MSB of X channel.

14th cycle: LSB of Y channel.

15th cycle: MSB of Y channel.

16th cycle: LSB of Z channel.

17th cycle: MSB of Z channel.

Master ends communications by NOT sending an 'Acknowledge' and also follows with a 'STOP' command.

EXAMPLE OF SET

1st cycle: A START condition is established by the Master Device followed by a call to the slave address [0110xxx] with the eighth bit held low to indicate a WRITE request. Note: [xxx] is determined by factory programming and a total of 8 different addresses are available.

2nd cycle: After an acknowledge signal is received by the master device (The MEMSIC device pulls the SDA line low during the 9th SCL pulse), the master device sends [00000111] as the target address (Internal Control Register 0). The MEMSIC device should acknowledge receipt of the address (9th SCL pulse).

3rd cycle: The Master device writes to the MEMSIC device's Internal Control Register 0 the code [10000000] (Refill Cap) to prepare for SET action.*

A minimum of 50ms wait should be provided to allow the MEMSIC device to finish its preparation for the SET action.

4th cycle: The Master device writes to the MEMSIC device's Internal Control 0 register the code

[00100000] (SET bit) to initiate a SET action. The MEMSIC device should send an Acknowledge.

EXAMPLE OF RESET*

1st cycle: A START condition is established by the Master Device followed by a call to the slave address [0110xxx] with the eighth bit held low to indicate a WRITE request. Note: [xxx] is determined by factory programming and a total of 8 different addresses are available.

2nd cycle: After an acknowledge signal is received by the master device (The MEMSIC device pulls the SDA line low during the 9th SCL pulse), the master device sends [00000111] as the target address (Internal Control Register 0). The MEMSIC device should acknowledge receipt of the address (9th SCL pulse).

3rd cycle: The Master device writes to the MEMSIC device's Internal Control Register 0 the code [10000000] (Refill Cap) to prepare for RESET action.

A minimum of 50ms wait should be provided to allow the MEMSIC device to finish its preparation for the RESET action.

4th cycle: The Master device writes to the MEMSIC device's Internal Control 0 register the code [01000000] (RESET bit) to initiate a RESET action. The MEMSIC device should send an Acknowledge.

At this point, the MEMSIC AMR sensors have been conditioned for optimum performance and data measurements can commence.

Note:

- The RESET action can be skipped for most applications.

USING SET AND RESET TO REMOVE BRIDGE OFFSET

The integrated SET and RESET functions of the MMC3416xPJ enables the user to remove the error associated with bridge Offset change as a function of temperature, thereby enabling more precise heading measurements over a wider temperature than competitive technologies. The SET and RESET functions effectively alternately flip the magnetic sensing polarity of the sensing elements of the device.

- 1) The most accurate magnetic field measurements can be obtained by using the protocol described as follows: Perform SET. This sets the internal magnetization of the sensing resistors in the direction of the SET field.
- 2) Perform MEASUREMENT. This measurement will contain not only the sensors response to the external magnetic field, H, but also the Offset; in other words,

$$\text{Output1} = +H + \text{Offset.}$$

- 3) Perform RESET. This resets the internal magnetization of the sensing resistors in the direction of the RESET field, which is opposite to the SET field (180° opposed).
- 4) Perform MEASUREMENT. This measurement will contain both the sensors response to the external field and also the Offset. In other words,

$$\text{Output2} = -H + \text{Offset.}$$





- 5) Finally, calculate H by subtracting the two measurements and dividing by 2. This procedure effectively eliminates the Offset from the measurement and therefore any changes in the Offset over temperature.

Note:

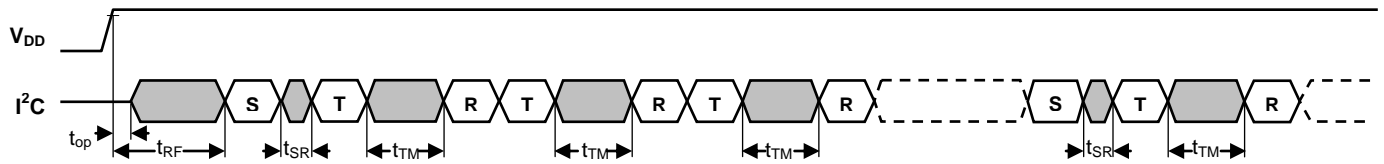
- To calculate and store the offset add the two measurements and divide by 2. This calculated offset value can be subtracted from subsequent measurements to obtain H directly from each measurement.

OPERATING TIMING



-  SET/RESET
-  Take Measurement
-  Read data
-  Repeat T & R
-  Wait the device to be ready for next operation

Operating Timing Diagram

Parameter	Symbol	Min.	Typ.	Max.	Unit
Time to operate device after V _{DD} valid	t _{op}	10			mS
Time from Refill Cap to SET/RESET	t _{RF}	50			mS
Wait time to complete SET/RESET	t _{SR}	1			mS
Wait time to complete measurement	t _{TM} BW=00	10			mS
	t _{TM} BW=01	5			mS
	t _{TM} BW=10	3			mS
	t _{TM} BW=11	1.5			mS

STORAGE CONDITIONS

Temperature: <30 °C
Humidity: <60%RH
Period: 1 year (after delivery)

Moisture Sensitivity Level: 3

Bake Prior to Reflow: storage period more than 1 year, or humidity indicator card reads >60% at 23±5 °C

Bake Procedure: refer to J-STD-033

Bake to Soldering: <1 week under 30 °C, 60%RH condition

SOLDERING RECOMMENDATIONS

MEMSIC magnetic sensor is capable of withstanding an MSL3 / 260°C solder reflow. Following is the reflow profile:

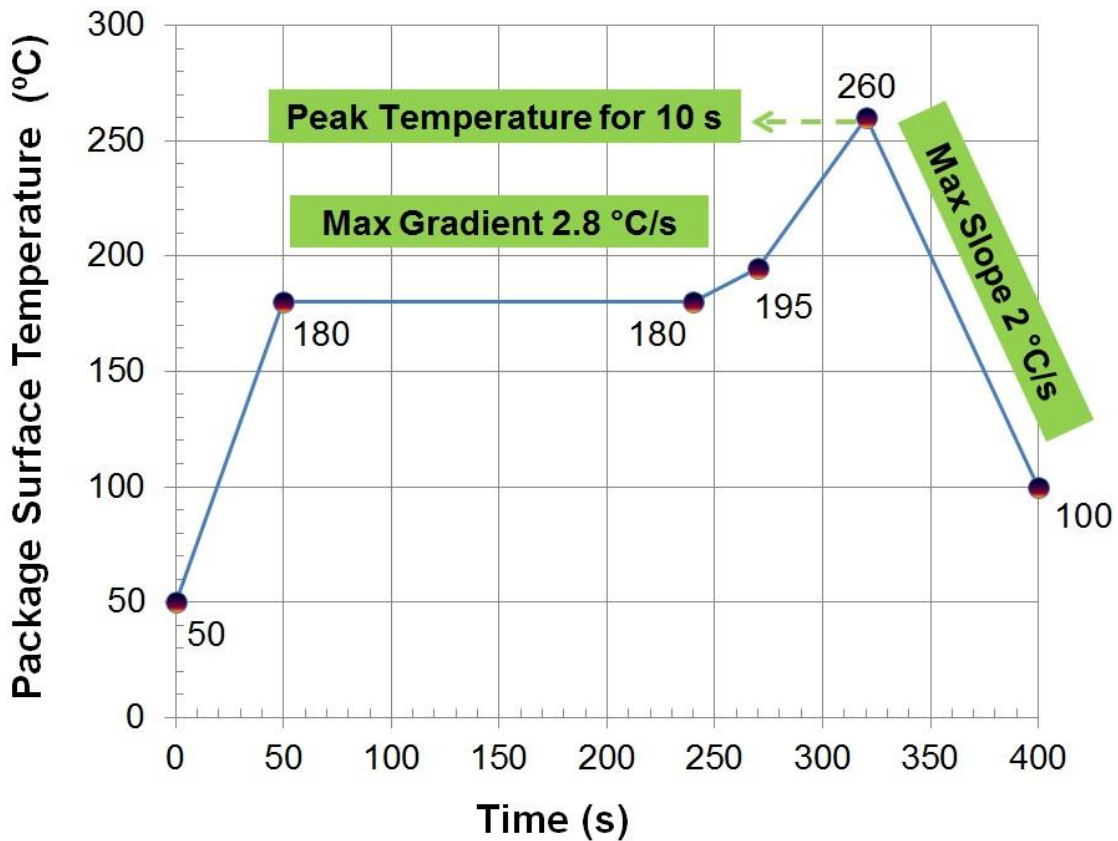

Note:

- Reflow is limited by 2 times
- The second reflow cycle should be applied after device has cooled down to 25 °C (room temperature)
- This is the reflow profile for Pb free process
- The peak temperature on the sensor surface should be limited under 260 °C for 10 seconds.
- Solder paste's reflow recommendation should be followed to get the best SMT quality.

If the part is mounted manually, please ensure the temperature could not exceed 260 °C for 10 seconds.

PACKAGE DRAWING (BGA package)

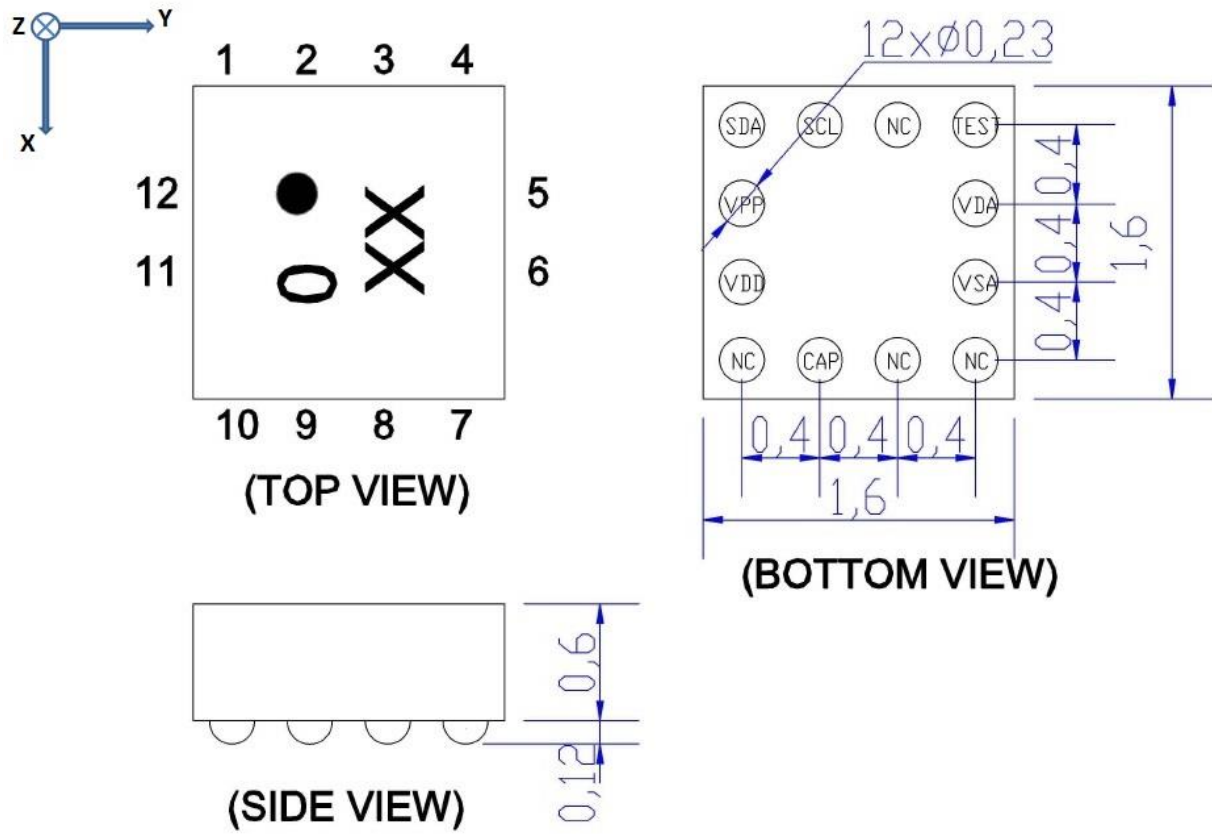

LAND PATTERN

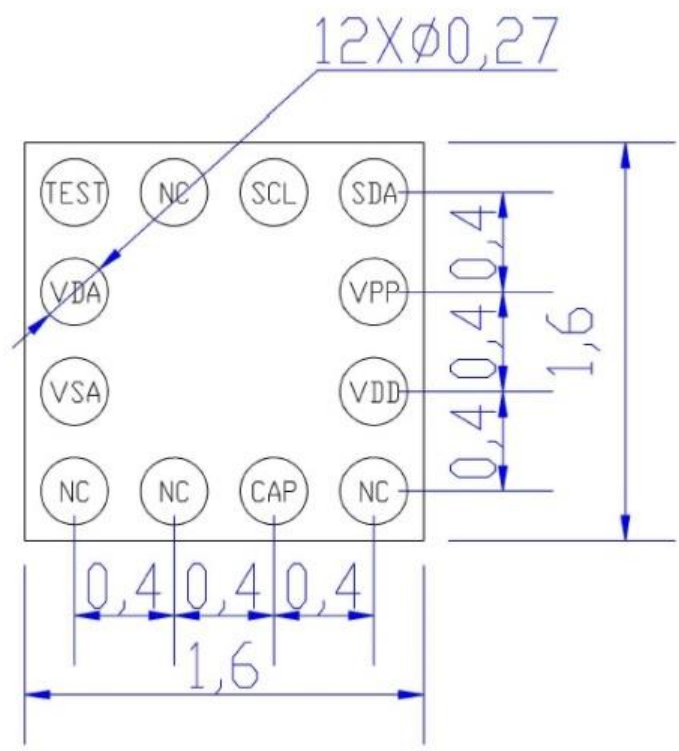

Компания «Океан Электроники» предлагает заключение долгосрочных отношений при поставках импортных электронных компонентов на взаимовыгодных условиях!

Наши преимущества:

- Поставка оригинальных импортных электронных компонентов напрямую с производств Америки, Европы и Азии, а так же с крупнейших складов мира;
- Широкая линейка поставок активных и пассивных импортных электронных компонентов (более 30 млн. наименований);
- Поставка сложных, дефицитных, либо снятых с производства позиций;
- Оперативные сроки поставки под заказ (от 5 рабочих дней);
- Экспресс доставка в любую точку России;
- Помощь Конструкторского Отдела и консультации квалифицированных инженеров;
- Техническая поддержка проекта, помощь в подборе аналогов, поставка прототипов;
- Поставка электронных компонентов под контролем ВП;
- Система менеджмента качества сертифицирована по Международному стандарту ISO 9001;
- При необходимости вся продукция военного и аэрокосмического назначения проходит испытания и сертификацию в лаборатории (по согласованию с заказчиком);
- Поставка специализированных компонентов военного и аэрокосмического уровня качества (Xilinx, Altera, Analog Devices, Intersil, Interpoint, Microsemi, Actel, Aeroflex, Peregrine, VPT, Syfer, Eurofarad, Texas Instruments, MS Kennedy, Miteq, Cobham, E2V, MA-COM, Hittite, Mini-Circuits, General Dynamics и др.);

Компания «Океан Электроники» является официальным дистрибьютором и эксклюзивным представителем в России одного из крупнейших производителей разъемов военного и аэрокосмического назначения «JONHON», а так же официальным дистрибьютором и эксклюзивным представителем в России производителя высокотехнологичных и надежных решений для передачи СВЧ сигналов «FORSTAR».



JONHON

«JONHON» (основан в 1970 г.)

Разъемы специального, военного и аэрокосмического назначения:

(Применяются в военной, авиационной, аэрокосмической, морской, железнодорожной, горно- и нефтедобывающей отраслях промышленности)

«FORSTAR» (основан в 1998 г.)

ВЧ соединители, коаксиальные кабели, кабельные сборки и микроволновые компоненты:

(Применяются в телекоммуникациях гражданского и специального назначения, в средствах связи, РЛС, а так же военной, авиационной и аэрокосмической отраслях промышленности).



Телефон: 8 (812) 309-75-97 (многоканальный)

Факс: 8 (812) 320-03-32

Электронная почта: ocean@oceanchips.ru

Web: <http://oceanchips.ru/>

Адрес: 198099, г. Санкт-Петербург, ул. Калинина, д. 2, корп. 4, лит. А