

# HEDT-9040, HEDT-9140

High Temperature 140°C  
Three Channel Optical  
Incremental Encoder Modules

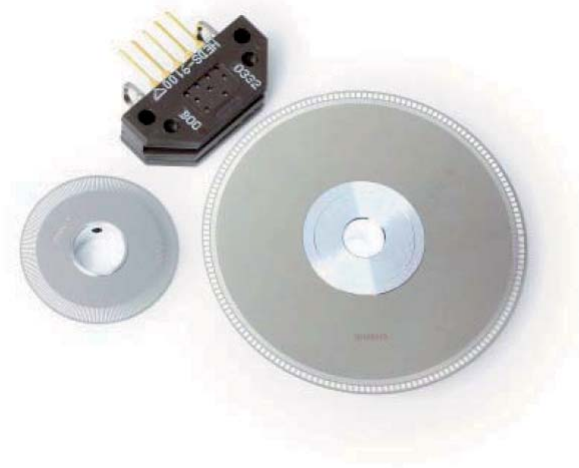

## Data Sheet



### Description

The HEDT-9040 and HEDT-9140 are high temperature three channel optical incremental encoder modules. When used with a codewheel, these low cost modules detect rotary position. Each module consists of a lensed LED source and a detector IC enclosed in a small plastic package. Due to a highly collimated light source and a unique photodetector array, these modules provide the same high performance found in the HEDS-9040/9140 three channel encoders.

The HEDT-9040 and 9140 have Block Diagram two channel quadrature outputs plus a third channel index output. This index output is a 90 electrical degree high true index pulse.

The HEDT-9040 is designed for codewheels which have an optical radius of 23.36 mm (0.920 in.). The HEDT-9140 is designed for codewheels which have an optical radius of 11.00 mm (0.433 in.).

The quadrature signals and the index pulse are accessed through five 0.025 inch square pins located on 0.1 inch centers.

Resolutions between 360 and 1024 counts per revolution are available. Consult local Avago sales representatives for other resolutions.

### Features

- -40°C to 140°C Operating Temperature
- Two Channel Quadrature Output with Index Pulse
- Suitable for Industrial Applications
- Resolution up to 1024 Counts per Revolution
- Low Cost
- Easy to Mount
- No Signal Adjustment Required
- Small Size

### Applications

The HEDT-9040 and 9140 provide high temperature motion control detection at a low cost, making them suitable for industrial applications.

Note: Avago Technologies encoders are not recommended for use in safety critical applications. Eg. ABS braking systems, power steering, life support systems and critical care medical equipment. Please contact sales representative if more clarification is needed.

**CAUTION:** It is advised that normal static precautions be taken in handling and assembly of this component to prevent damage and/or degradation which may be induced by ESD.

# Package Dimensions

## HEDT-9040

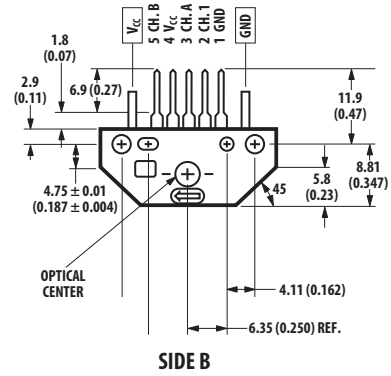
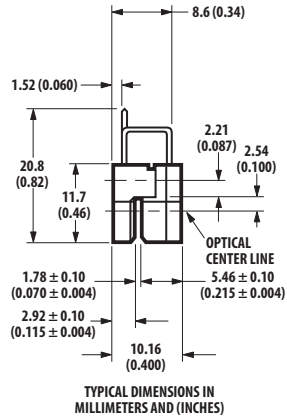
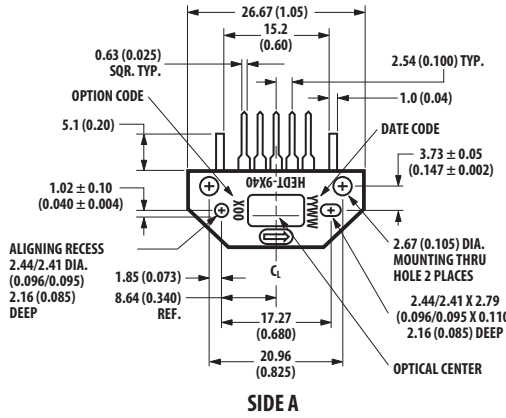

## HEDT-9041

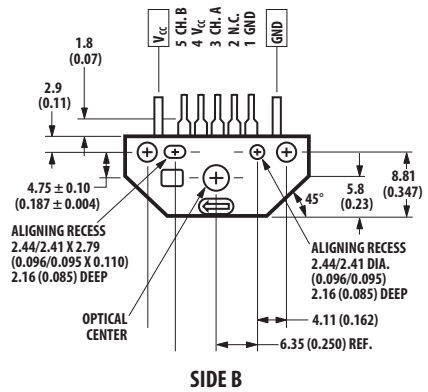
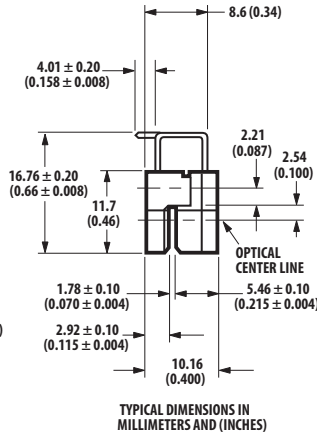
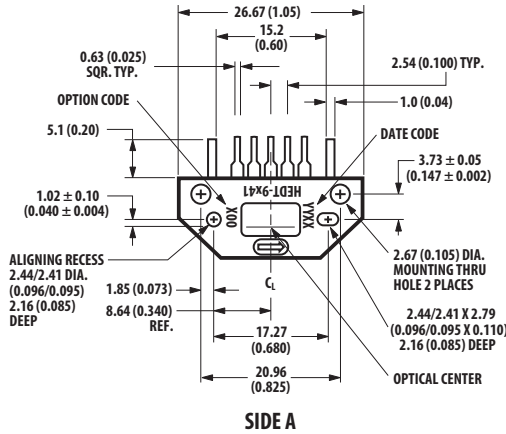

## Theory of Operation

The HEDT-9040 and 9104 are emitter/detector modules. Coupled with a codewheel, these modules translate the rotary motion of a shaft into a threechannel digital output.

As seen in the block diagram, the module contains a single Light Emitting Diode (LED) as its light source. The light is collimated into a parallel beam by means of a single lens located directly over the LED. Opposite the emitter is the integrated detector circuit. This IC consists of multiple sets of photodetectors and the signal processing circuitry necessary to produce the digital waveforms.

The codewheel rotates between the emitter and detector, causing the light beam to be interrupted by the pattern of spaces and bars on the codewheel. The photodiodes which detect these interruptions are arranged in a pattern that corresponds to the radius and design of the

codewheel. These detectors are also spaced such that a light period on one pair of detectors corresponds to a dark period on the adjacent pair of detectors. The photodiode outputs are then fed through the signal processing circuitry resulting in  $A$ ,  $\bar{A}$ ,  $B$ ,  $\bar{B}$ ,  $I$  and  $\bar{I}$ . Comparators receive these signals and produce the final outputs for channels A and B. Due to this integrated phasing technique, the digital output of channel A is in quadrature with that of channel B (90 degrees out of phase).

The output of the comparator for  $I$  and  $\bar{I}$  is sent to the index processing circuitry along with the outputs of channels A and B. The final output of channel I is an index pulse  $P_0$  which is a one state width (nominally 90 electrical degrees), high true index pulse. This pulse is coincident with the low states of channels A and B.

## Block Diagram

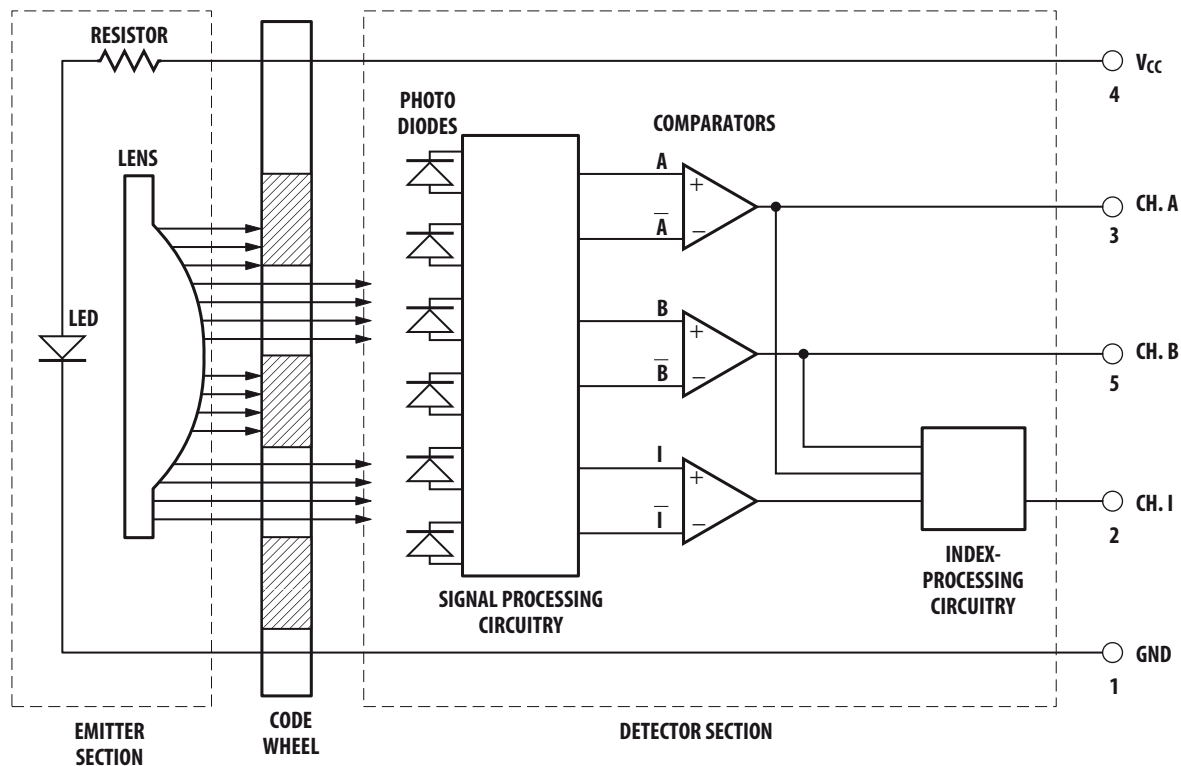

## Output Waveforms

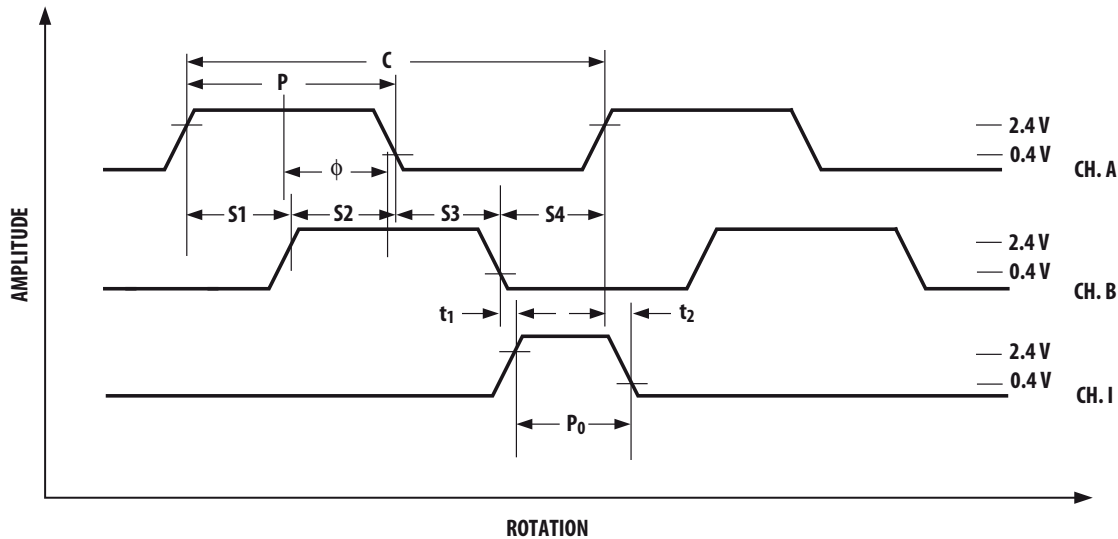

## Definitions

**Count (N):** The number of bar and window pairs or counts per revolution (CPR) of the codewheel.

**One Cycle (C):** 360 electrical degrees (°e), 1 bar and window pair.

**One Shaft Rotation:** 360 mechanical degrees, N cycles.

**Position Error ( $\Delta\Theta$ ):** The normalized angular difference between the actual shaft position and the position indicated by the encoder cycle count.

**Cycle Error ( $\Delta C$ ):** An indication of cycle uniformity. The difference between an observed shaft angle which gives rise to one electrical cycle, and the nominal angular increment of  $1/N$  of a revolution.

**Pulse Width (P):** The number of electrical degrees that an output is high during 1 cycle. This value is nominally 180°e or 1/2 cycle.

**Pulse Width Error ( $\Delta P$ ):** The deviation, in electrical degrees, of the pulse width from its ideal value of 180°e.

**State Width (S):** The number of electrical degrees between a transition in the output of channel A and the neighboring transition in the output of channel B. There are 4 states per cycle, each nominally 90°e.

**State Width Error ( $\Delta S$ ):** The deviation, in electrical degrees, of each state width from its ideal value of 90°e.

**Phase ( $\phi$ ):** The number of electrical degrees between the center of the high state of channel A and the center of the high state of channel B. This value is nominally 90°e for quadrature output.

**Phase Error ( $\Delta\phi$ ):** The deviation of the phase from its ideal value of 90°e.

**Direction of Rotation:** When the codewheel rotates in the direction of the arrow on top of the module, channel A will lead channel B. If the codewheel rotates in the opposite direction, channel B will lead channel A.

**Optical Radius ( $R_{op}$ ):** The distance from the codewheel's center of rotation to the optical center (O.C.) of the encoder module.

**Index Pulse Width ( $P_0$ ):** The number of electrical degrees that an index is high during one full shaft rotation. This value is nominally 90°e or 1/4 cycle.

## Absolute Maximum Ratings

Parameter	Symbol	Minimum	Typical	Maximum	Units
Storage Temperature	T <sub>S</sub>	-40		140	°C
Operating Temperature	T <sub>A</sub>	-40		140	°C
Supply Voltage	V <sub>CC</sub>	-0.5		7	V
Output Voltage	V <sub>O</sub>		-0.5 V to V <sub>CC</sub>		V
Output Current per Channel	I <sub>OUT</sub>	-1.0		5	mA
Shaft Axial Play				± 0.25 (± 0.010)	mm (in.)
Shaft Eccentricity Plus Radial Play				0.1 (0.004)	mm (in.) TIR
Velocity			30,000		RPM <sup>[1]</sup>
Acceleration			250,000		rad/sec <sup>2</sup> <sup>[1]</sup>

Note:

1. Absolute maximums for HEDS-5140 codewheel only.

## Recommended Operating Conditions

Parameter	Symbol	Min.	Typ.	Max.	Units	Notes
Temperature	T <sub>A</sub>	-40		140	°C	
Supply Voltage	V <sub>CC</sub>	4.5	5.0	5.5	Volts	Ripple < 100 mV <sub>p-p</sub>
Load Capacitance	C <sub>L</sub>			100	pF	2.7 kΩ pull-up
Count Frequency	f			50	kHz	Velocity (rpm) x N/60
Shaft Perpendicularity Plus Axial Play				± 0.25 (± 0.010)	mm (in.)	6.9 mm (0.27 in.) from mounting surface
Shaft Eccentricity Plus Radial Play				0.04 (0.0015)	mm (in.) TIR	6.9 mm (0.27 in.) from mounting surface

Note: The module performance is guaranteed to 50 kHz but can operate at higher frequencies.

## Encoding Characteristics

Encoding Characteristics over Recommended Operating Range and Recommended Mounting Tolerances unless otherwise specified. Values are for the worst error over the full rotation of HEDS-514X and HEDS-6145 codewheels.

Parameter	Symbol	Min.	Typ.*	Max.	Units
Cycle Error	ΔC		5	10	°e
Pulse Width Error	ΔP		7	30	°e
Logic State Width Error	ΔS		5	30	°e
Phase Error	Δφ		2	15	°e
Position Error	ΔΘ		10	40	min. of arc
Index Pulse Width	P <sub>O</sub>	60	90	120	°e
CH. I rise after CH. B or CH. A fall	t <sub>1</sub>	20	430	1490	ns
CH. I fall after CH. A or CH. B rise	t <sub>2</sub>	40	250	620	ns

Note: Module mounted on tolerance circle of ± 0.13 mm (± 0.005 in.) radius referenced from module Side A aligning recess centers. 2.7 kΩ pull-up resistors used on all encoder module outputs.

## Electrical Characteristics

Electrical Characteristics over Recommended Operating Range.

Parameter	Symbol	Min.	Typ.*	Max.	Units	Notes
Supply Current	$I_{CC}$	30	57	85	mA	
High Level Output Voltage	$V_{OH}$	2.4			V	$I_{OH} = -100$ mA min.
Low Level Output Voltage	$V_{OL}$			0.4	V	$I_{OL} = 3.86$ mA max.
Rise Time	$t_r$		90		ns	$C_L = 25$ pF
Fall Time	$t_f$		80		ns	$R_L = 2.7$ k $\Omega$ pull-up

\*Typical values specified at  $V_{CC} = 5.0$  V and  $25^\circ\text{C}$ .

## Mechanical Characteristics

Part No.	Parameter	Dimension	Tolerance	Units
HEDS-5140 11.00 mm optical radius codewheel	Codewheel Available to	2 3 4	+0.000	mm
	Fit These Standard Shaft Diameters	5 6 8	-0.015	
	Moment of Inertia	5/32 1/8	+0.000	in.
		3/16 1/4	-0.0007	
		0.6 (8.0 x 10 <sup>-6</sup> )		g-cm <sup>2</sup> (oz-in-s <sup>2</sup> )

Note: The tolerance requirements are on the mating shaft, not on the codewheel.

## Electrical Interface

To insure reliable encoding performance, the HEDT-9040 and 9140 three channel encoder modules require 2.7 kW ( $\pm 10\%$ ) pull-up resistors on output pins 2, 3, and 5 (Channels I, A, and B) as shown in Figure 1. These pull-up resistors should be located in close proximity of the encoder module (within 4 feet). Each of the three encoder module outputs can drive a single TTL load in this configuration.

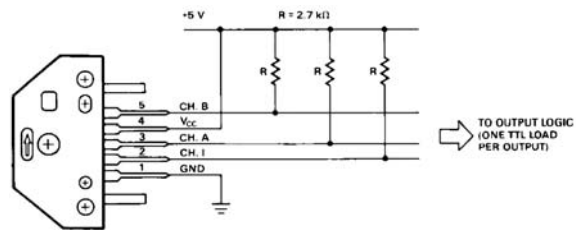

Figure 1. Pull-up Resistors on HEDT-9X40 Encoder Module Outputs.

## Mounting Considerations

Figure 2 shows a mounting tolerance requirement for proper operation of the HEDT-9040 and HEDT-9140. The Aligning Recess Centers must be located within a tolerance circle of 0.13 mm (0.005 in.) radius from the nominal locations. This tolerance must be maintained whether the module is mounted with Side A as the mounting plane using aligning pins (see Figure 5), or mounted with Side B as the mounting plane using an alignment tool (see Figures 3 and 4).

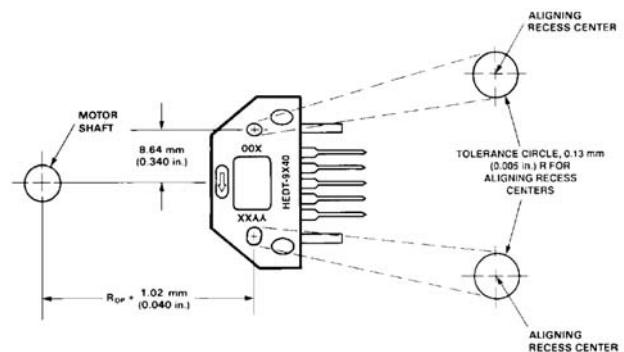

Figure 2. HEDT-9X40 Mounting Tolerance.

## Mounting the HEDT-9140 with an Alignment Tool

The HEDS-8905 alignment tool is recommended for mounting the HEDT-9140 module with Side B as the mounting plane. This tool can only be used when the HEDT-9140 module is mounted with the HEDS-5140 (codewheel with hub). The HEDS-8905 tool fixes the module position using the codewheel hub as a reference. It will not work if Side A is used as the mounting plane.

The following assembly procedure uses the HEDS-8905 alignment tool to mount an HEDT-9140 module and an HEDS-5140 codewheel:

### Instructions:

1. Place codewheel on shaft.
2. Set codewheel height: (a) place alignment tool on motor base (pins facing up) flush up against the motor shaft as shown in Figure 3. (b) Push codewheel down against alignment tool. The codewheel is now at the proper height. (c) Tighten codewheel setscrew and remove alignment tool.

Some motors have a boss around the shaft that extends above the mounting plane. In this case, the alignment tool cannot be used as a gage block to set the codewheel height as described in 2(a), (b), and (c). *If boss is above mounting plane:* Slide module onto motor base, adjusting height of codewheel so that it sits approximately in the middle of module slot. Lightly tighten setscrew. The codewheel height will be more precisely set in step 5.

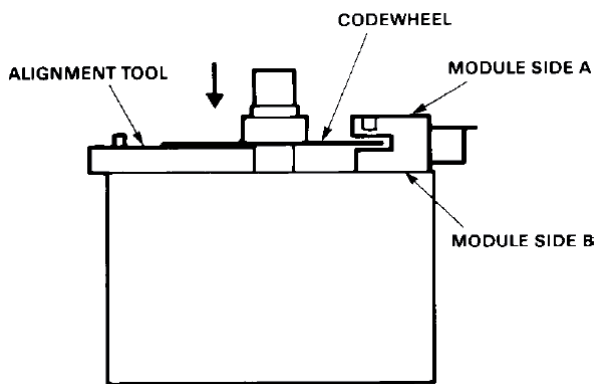

Figure 3. Alignment Tool is Used to Set Height of Codewheel.

3. Insert mounting screws through module and thread into the motor base. Do not tighten screws.
4. Slide alignment tool over codewheel hub and onto module as shown in Figure 4. The pins of the alignment tool should fit snugly inside the alignment recesses of the module.

*If boss is above mounting plane:* The pins of the tool may not mate properly because the codewheel is too high on the shaft. Loosen codewheel setscrew and lower codewheel slightly. Retighten setscrew lightly and attempt this step again.

5. While holding alignment tool in place, tighten screws down to secure module.

*If boss is above mounting plane:* Push codewheel up flush against alignment tool to set codewheel height. Tighten codewheel setscrew.

6. Remove alignment tool.

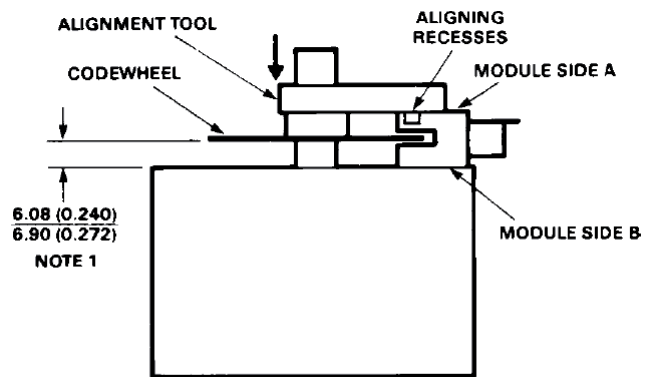

NOTE 1: THIS DIMENSION IS FROM THE MOUNTING PLANE TO THE NON-HUB SIDE OF THE CODEWHEEL.

Figure 4. Alignment Tool is Placed over Shaft and onto Codewheel Hub. Alignment Tool Pins Mate with Aligning Recesses on Module.

## Mounting with Aligning Pins

The HEDT-9040 and HEDT-9140 can also be mounted using aligning pins on the mounting surface. (Avago does not provide aligning pins.) For this configuration, Side A must be used as the mounting plane. The aligning recess centers must be located within the 0.13 mm (0.005 in.) Radius Tolerance Circle as explained in "Mounting Considerations." Figure 5 shows the necessary dimensions.

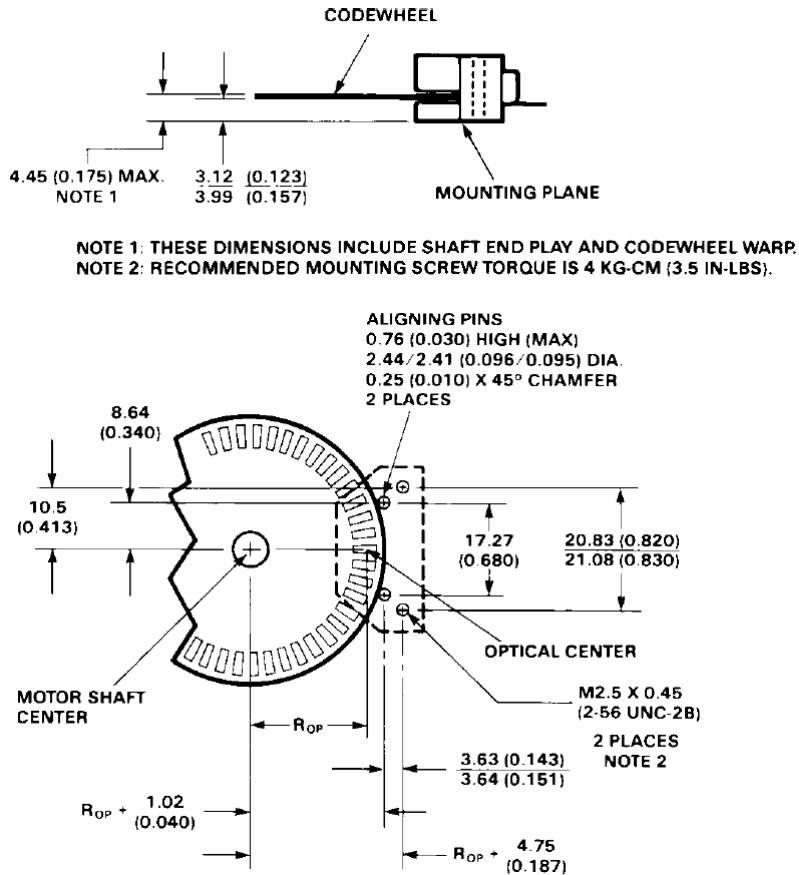

Figure 5. Mounting Plane Side A.

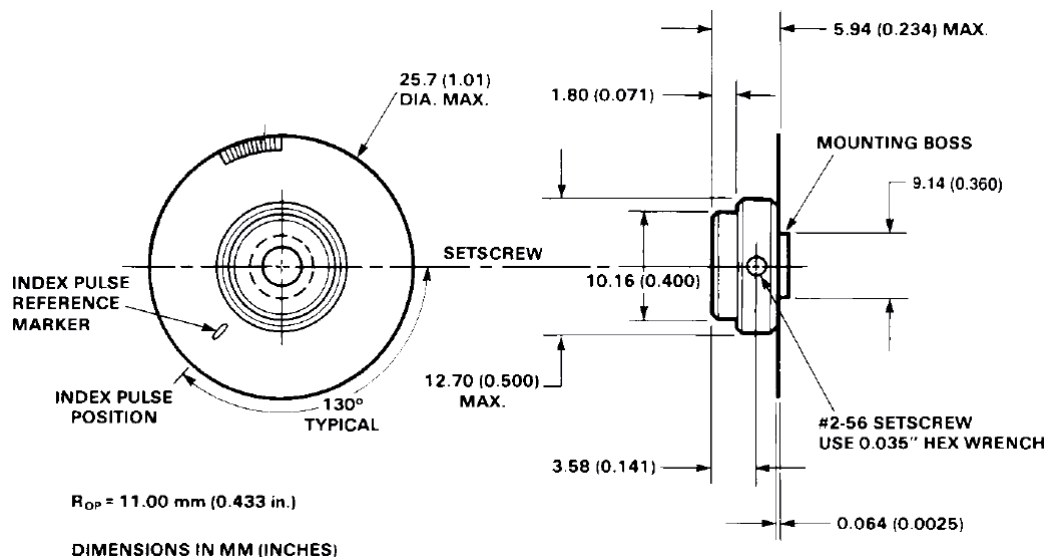
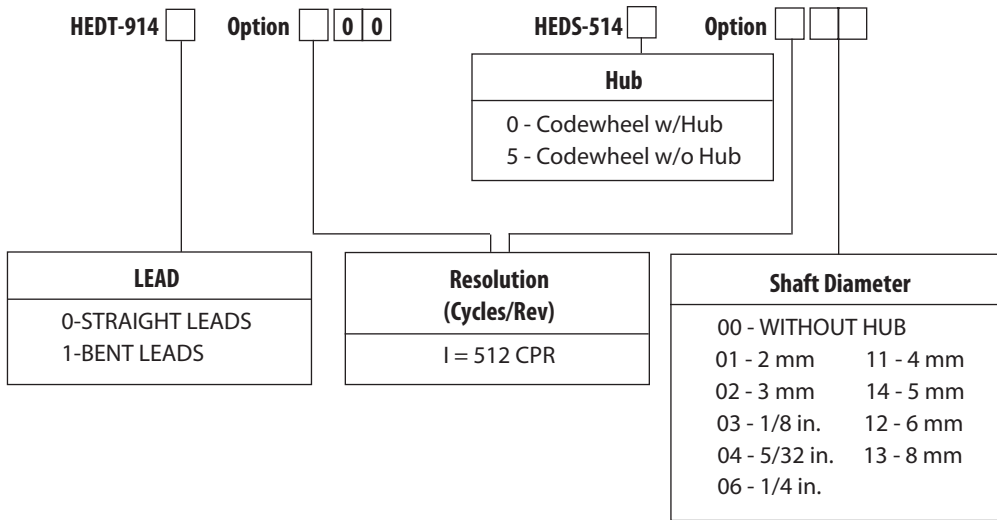

Figure 6. HEDS-5140 Codewheel Used with HEDT-9140.



## Ordering Information

Three Channel Encoder Modules and Codewheels, 11.00 mm Optical Radius



	A	E	F	G	I
<b>HEDT-9140</b>					*
<b>HEDT-9141</b>					*

		01	02	03	04	05	06	08	09	10	11	12	13	14
<b>HEDS-5140</b>	I		*		*		*				*	*	*	*

## Accessories

### HEDS-8905

Alignment Tool for mounting the HEDT-9140.

## Using Multiple Index Pulses

The third channel index (Channel I) is not limited to occurring just once per revolution. Index pulses may be placed arbitrarily over a full codewheel rotation. This is done by altering only the pattern of the codewheel with no modifications necessary to the HEDT-9X40 module. The only restriction is that, depending on the CPR of the codewheel, consecutive index pulses may have to be separated by at least 10 full cycles.

Multiple index pulses can provide more precise absolute position information. By strategically placing the index

pulses, a unique index series can be created for a particular angular position. This leads to the idea of the “quasiabsolute” encoder in which only a partial turning of the codewheel is required to determine the absolute position.

A special codewheel is required to accomplish a multiple index pattern. The standard HEDS-5140, 5145, and 6145 codewheels have one index pulse per full revolution. Please consult a local Avago sales representative for further information.

For product information and a complete list of distributors, please go to our web site: [www.avagotech.com](http://www.avagotech.com)

Avago, Avago Technologies, and the A logo are trademarks of Avago Technologies in the United States and other countries. Data subject to change. Copyright © 2005-2011 Avago Technologies. All rights reserved.  
AV02-1932EN - January 12, 2011

**AVAGO**  
TECHNOLOGIES

Компания «Океан Электроники» предлагает заключение долгосрочных отношений при поставках импортных электронных компонентов на взаимовыгодных условиях!

Наши преимущества:

- Поставка оригинальных импортных электронных компонентов напрямую с производств Америки, Европы и Азии, а так же с крупнейших складов мира;
- Широкая линейка поставок активных и пассивных импортных электронных компонентов (более 30 млн. наименований);
- Поставка сложных, дефицитных, либо снятых с производства позиций;
- Оперативные сроки поставки под заказ (от 5 рабочих дней);
- Экспресс доставка в любую точку России;
- Помощь Конструкторского Отдела и консультации квалифицированных инженеров;
- Техническая поддержка проекта, помощь в подборе аналогов, поставка прототипов;
- Поставка электронных компонентов под контролем ВП;
- Система менеджмента качества сертифицирована по Международному стандарту ISO 9001;
- При необходимости вся продукция военного и аэрокосмического назначения проходит испытания и сертификацию в лаборатории (по согласованию с заказчиком);
- Поставка специализированных компонентов военного и аэрокосмического уровня качества (Xilinx, Altera, Analog Devices, Intersil, Interpoint, Microsemi, Actel, Aeroflex, Peregrine, VPT, Syfer, Eurofarad, Texas Instruments, MS Kennedy, Miteq, Cobham, E2V, MA-COM, Hittite, Mini-Circuits, General Dynamics и др.);

Компания «Океан Электроники» является официальным дистрибьютором и эксклюзивным представителем в России одного из крупнейших производителей разъемов военного и аэрокосмического назначения «JONHON», а так же официальным дистрибьютором и эксклюзивным представителем в России производителя высокотехнологичных и надежных решений для передачи СВЧ сигналов «FORSTAR».



## JONHON

«JONHON» (основан в 1970 г.)

Разъемы специального, военного и аэрокосмического назначения:

(Применяются в военной, авиационной, аэрокосмической, морской, железнодорожной, горно- и нефтедобывающей отраслях промышленности)

«FORSTAR» (основан в 1998 г.)

ВЧ соединители, коаксиальные кабели, кабельные сборки и микроволновые компоненты:

(Применяются в телекоммуникациях гражданского и специального назначения, в средствах связи, РЛС, а так же военной, авиационной и аэрокосмической отраслях промышленности).



Телефон: 8 (812) 309-75-97 (многоканальный)

Факс: 8 (812) 320-03-32

Электронная почта: [ocean@oceanchips.ru](mailto:ocean@oceanchips.ru)

Web: <http://oceanchips.ru/>

Адрес: 198099, г. Санкт-Петербург, ул. Калинина, д. 2, корп. 4, лит. А