

From Off-The-Shelf to Market-Ready© New Age Enclosures is your Single Source Solution.
Let us quote modifying our Stock Enclosures to meet your end-use.
visit newageenclosures.com/services or call 855-4NA-ENCL today.

CNC CUTOUTS
PART DECORATING
CUSTOM COLOR AND MATERIAL
RF/EMI SHEILDING
CUSTOM TOOL INSERTS
CUSTOM ENCLOSURES AND DESIGN

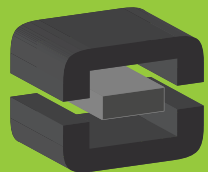

NEW AGE
ENCLOSURES

DEVELOP THE FUTURE



180804(x) CONFIGURATIONS							
	-S	-U	-62U	-SB	-UB	-62UB	-B
180804 COVER	1						
180804 COVER w/USB OPENING		1	1				
180804 COVER w/BUTTON HOLE				1		1	
180804 COVER w/USB & BUTTON HOLE					1		
180804 BASE	1			1			
180804 BASE w/USB		1			1		
180804 BASE w/USB w/.062 PCB			1			1	
180804 BUTTON							1

R E V I S I O N					
REV.	DRAWN BY	ECO No	DESCRIPTION	DATE	APPROVED
1	M BOYER		PRELIMINARY RELEASE	2005-May-04	D.C.
			REVISIONS 2-11 ARCHIVED ON REV 12.1		
			REVISIONS 12.0-13.1 ARCHIVED ON REV 13.1		
14.0	M BOYER	02316	UPDATE CONFIGURATION TREE	2016-Apr-20	D.C.
15.0	M BOYER	04516	ADD .062" PCB OPTION TO CONFIGURATION TREE	2016-Sep-02	D.C.
16.0	M BOYER	03117	MAKE REFERENCE TO WALL RIB IN BASE NOT AVAILABLE IN ALL VERSIONS	2017-Dec-14	

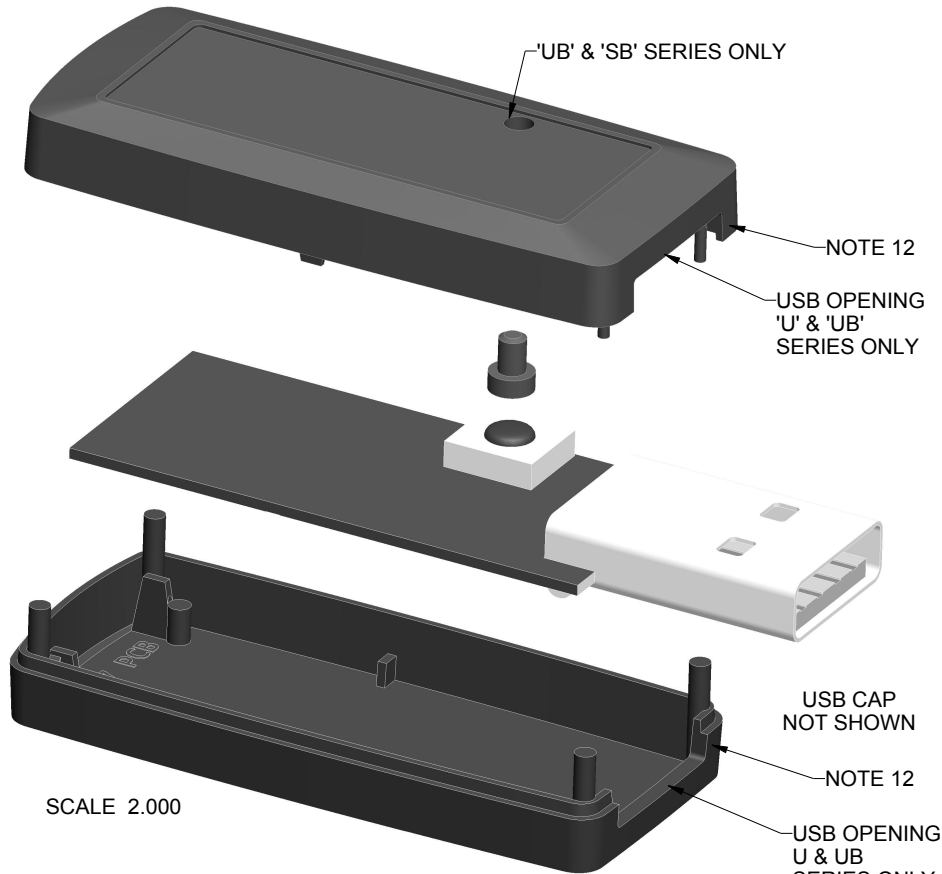

SCALE 2.000

NOTES: UNLESS OTHERWISE SPECIFIED

- CORNERS DRAWN SHARP TO BE R.005 MAXIMUM.
- EXTERIOR SURFACE TEXTURE TO BE LIGHT EDM FINISH (EQUIVALENT TO MT-11010.)
- INTERIOR SURFACE TEXTURE TO BE: NONE
- ALL INSIDE RADII .010R, UNLESS OTHERWISE SPECIFIED.
- ALL EXTERNAL DIMENSIONS AFFECTED BY THE DRAFT APPLY AT THE LARGE END OF THE FEATURE, AND ALL INTERNAL FEATURES AFFECTED BY THE DRAFT APPLY AT THE SMALL END OF THE FEATURE UNLESS OTHERWISE SPECIFIED.
- 1 DEGREE DRAFT IN THE DIRECTION OF PULL IS PERMISSIBLE UNLESS OTHERWISE SPECIFIED.
- THIS ENCLOSURE IS A PRESS FIT ASSEMBLY. FOR PERMANENT CLOSURE: A DROP ADHESIVE OR ULTRASONIC WELDING IS REQUIRED.
- MATERIAL / COLOR: ABS PLASTIC IS STANDARD IN BLACK OR WHITE. CUSTOM MATERIALS AND COLORS ARE AVAILABLE UPON REQUEST FOR QUOTE.
- PCB SIZES ARE RECOMMENDATIONS ONLY. FINAL SIZES AND VERIFICATION OF ITS FIT ARE THE SOLE RESPONSIBILITY OF EACH CUSTOMER.
- STANDARD OR CUSTOM LABEL RECESSES ARE AVAILABLE FOR QUOTE.
- "STANDARD" VERSION ENCLOSURE COVER NOT AVAILABLE WITH RIBS. SEE SHEET 4 FOR DETAILS.
- THE GATE REMNANT FOR THIS ENCLOSURE IS LOCATED IN THIS POSITION TO MINIMIZE ANY COSMETIC IMPACT. IT IS HOWEVER VISIBLE AND VARIES IN SIZE / SHAPE. IT IS EASILY REMOVED WITH CLIPPERS. IF YOU WOULD LIKE NEW AGE TO CLIP THIS FOR YOU, PLEASE ASK YOUR SALES REPRESENTATIVE FOR A FREE QUOTE.
- ASSEMBLY POST DIMENSIONS WILL VARY DEPENDING ON THE "PRESS FIT" OF THE ENCLOSURE.

ITEM	DESCRIPTION	MATERIAL	COLOR	QTY.
4	180804 PCB - REFERENCE	.027"-.062" THICK	CUSTOMER SUPPLIED	1
3	180804UB COVER - STANDARD	ABS	BLACK or WHITE	1
2	180804UB BASE - STANDARD	ABS	BLACK or WHITE	1
1	180804 BUTTON	SOLD SEPARATE	--	1

BILL OF MATERIALS

THIRD ANGLE PROJECTION DO NOT SCALE DRAWING	TOLERANCES: UNLESS OTHERWISE SPECIFIED DIMENSIONS ARE IN U.S. INCHES. X.XX = .015 X.XXXX = .001 X.XXX = .010 X.X" = 1°	NEW AGE ENCLOSURES 2240 South Thornburg Street Santa Maria, CA. 93455 ph. (805) 595-1310 fax (805) 595-1024 www.newageenclosures.com	
	NEW AGE ENCLOSURES Customer's Part No: 180804		
APPROVAL BY DATE CHECK _____ ENG. _____ SCALE AS NOTED	DRAWN BY M BOYER DATE 2005-May-04	SIZE A DRAWING NAME 180804_R16_0	SHEET 1 OF 8 REV.DOC 16.0

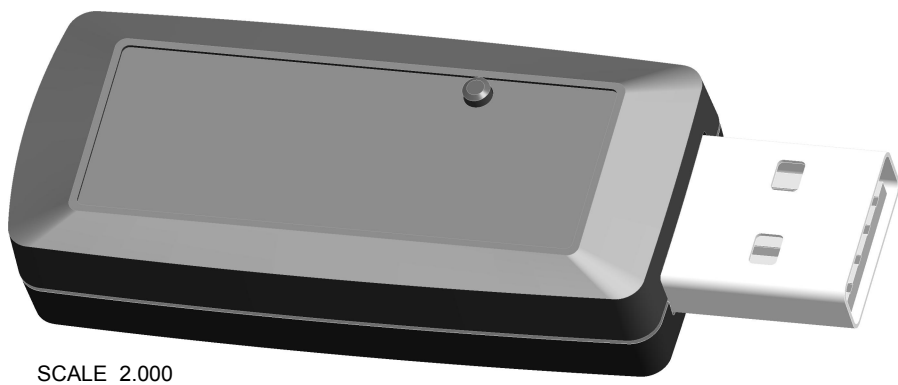
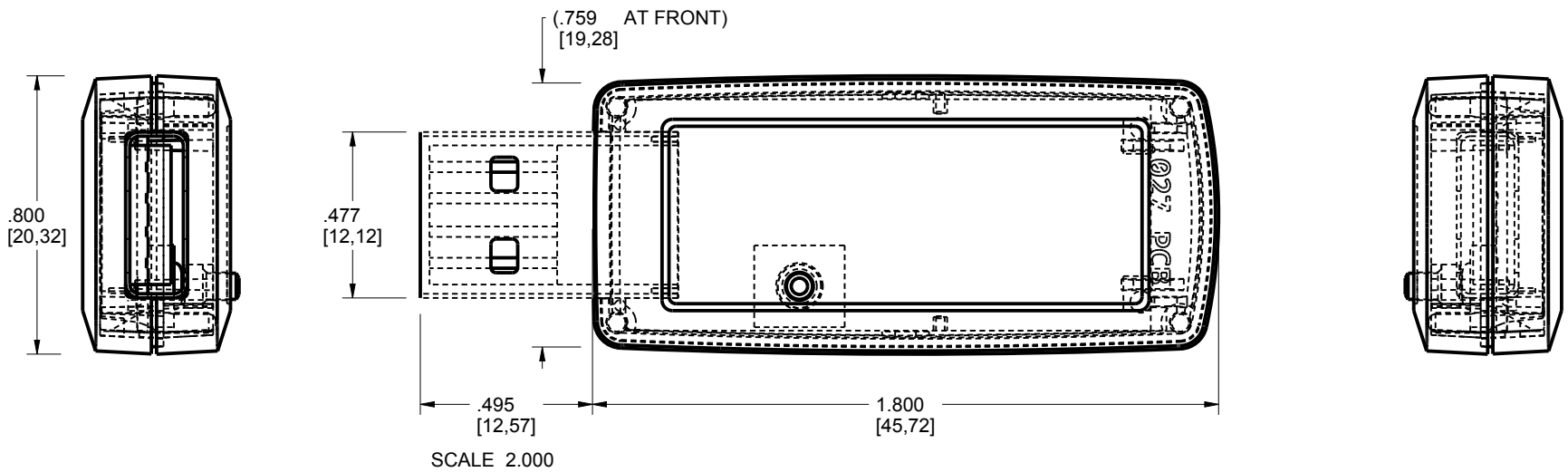

SCALE 2.000

TOLERANCES: UNLESS OTHERWISE SPECIFIED
DIMENSIONS ARE IN U.S. INCHES.
X.XX = .015 X.XXXX = .001
X.XXX = .010 X.X° = 1°

NEW AGE ENCLOSURES
Customer's Part No: 180804

APPROVAL	BY	DATE
CHECK		
ENG.		
SCALE	AS NOTED	

DRAWN BY	2005-May-04
M BOYER	

NEW AGE ENCLOSURES
2240 South Thornburg Street Santa Maria, CA. 93455
ph. (805) 595-1310 fax (805) 595-1024
www.newageenclosures.com

**STANDARD - USB DRIVE
PXX-180804XX-XXX**

SIZE	DRAWING NAME	SHEET	REV.DOC
A	180804_R16_0	2 OF 8	16.0

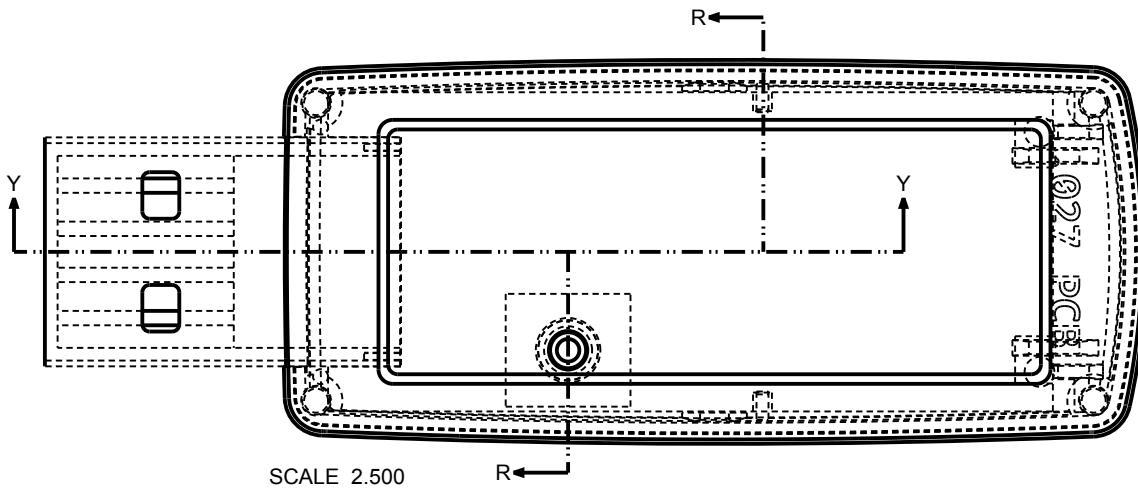

SCALE 2.500

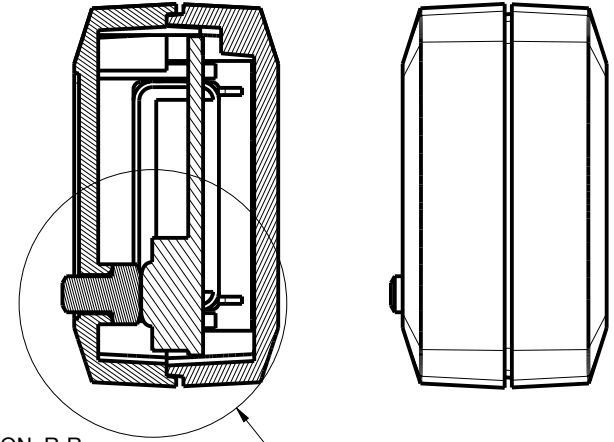

SECTION R-R

SEE DETAIL A

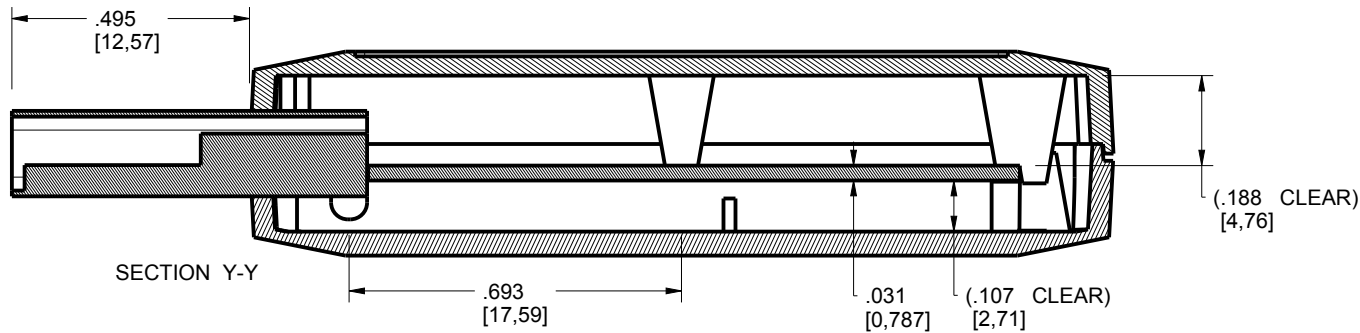

SECTION Y-Y

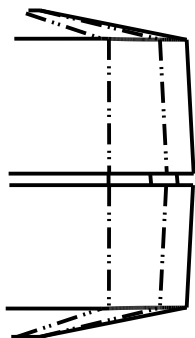

SECTION P-P
SCALE 4.000

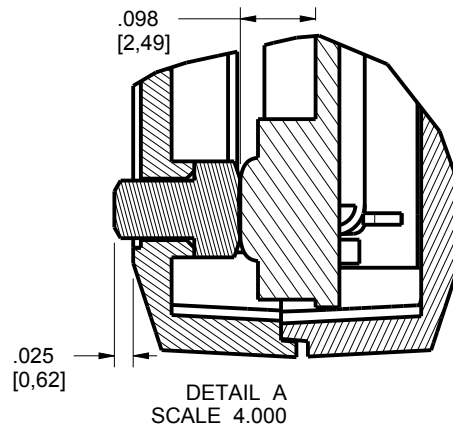

DETAIL A
SCALE 4.000

TOLERANCES: UNLESS OTHERWISE SPECIFIED
DIMENSIONS ARE IN U.S. INCHES.

X.XX = .015 X.XXXX = .001
X.XXX = .010 X.X° = 1°

NEW AGE ENCLOSURES

Customer's Part No: 180804

APPROVAL BY DATE

CHECK

ENG.

SCALE AS NOTED

DRAWN BY M BOYER 2005-May-04

NEW AGE ENCLOSURES

2240 South Thornburg Street Santa Maria, CA. 93455
ph. (805) 595-1310 fax (805) 595-1024

www.newageenclosures.com
**STANDARD - USB DRIVE
PXX-180804XX-XXX**

SIZE A DRAWING NAME 180804_R16_0

SHEET 3 OF 8 REV.DOC 16.0

180804 COVER

NOTE: CONFIGURATION 180804-S ONLY
 1. END RIBS NOT INCLUDED
 2. 1 DEGREE DRAFT ON SIDE RIB
 3. ALIGNMENT POSTS .080" TALL

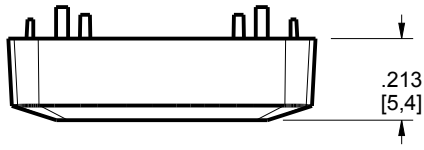

INTERIOR SUPPORT RIBS
 NOT AVAILABLE ON
 -S CONFIGURATION

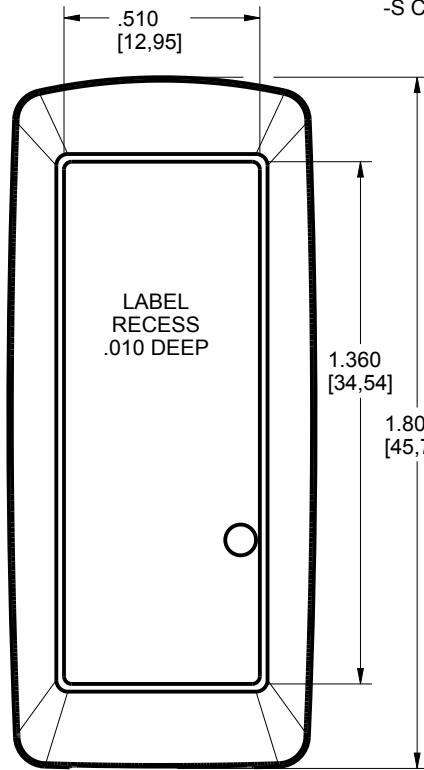

SCALE 2.000

3° DRAFT TYP.

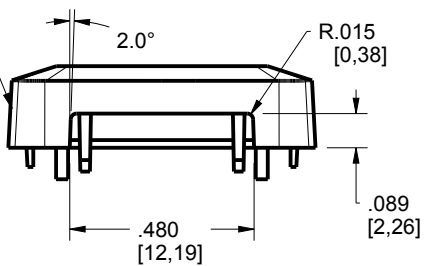

.032 FOR -S CONFIGURATION
 .010 FOR -U/-UB CONFIGURATION

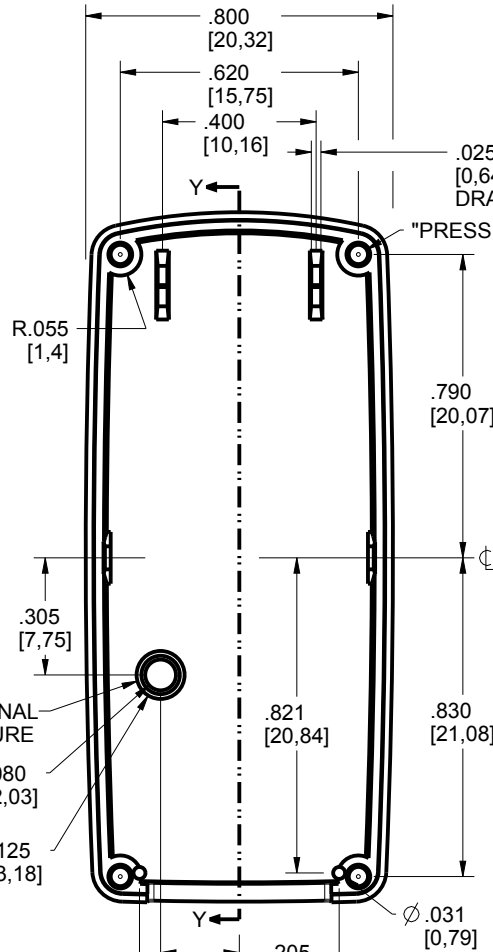
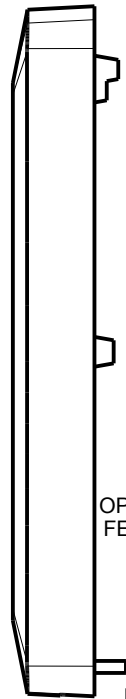

SEE DETAIL R

.025 +1°
 [0,64]
 DRAFT/SIDE

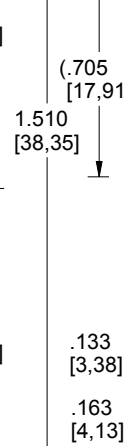

SECTION Y-Y

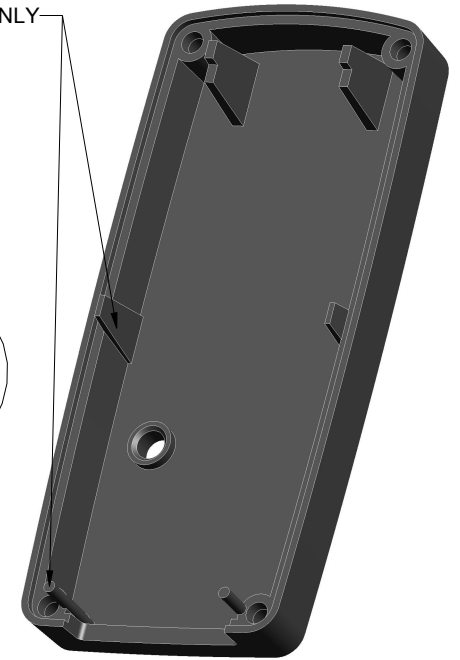

SCALE 2.000



TOLERANCES: UNLESS OTHERWISE SPECIFIED
 DIMENSIONS ARE IN U.S. INCHES.
 X.XX = .015 X.XXXX = .001
 X.XXX = .010 X.XX° = 1°

NEW AGE ENCLOSURES

Customer's Part No: 180804

APPROVAL	BY	DATE
CHECK		
ENG.		
SCALE	AS NOTED	

DRAWN BY
 M BOYER

2005-May-04

NEW AGE ENCLOSURES

2240 South Thornburg Street Santa Maria, CA. 93455
 ph. (805) 595-1310 fax (805) 595-1024
www.newageenclosures.com

STANDARD - USB DRIVE
 PXX-180804XX-XXX

SIZE A
 DRAWING NAME 180804_R16_0

SHEET 4 OF 8
 REV.DOC 16.0

180804 BASE

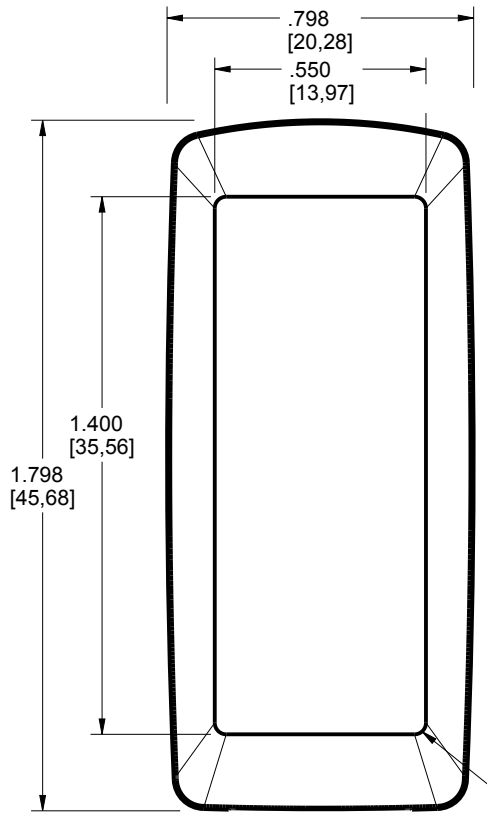
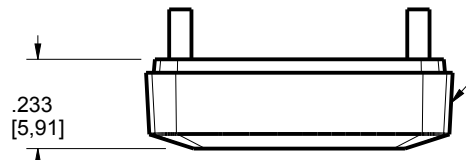

SCALE 2.000

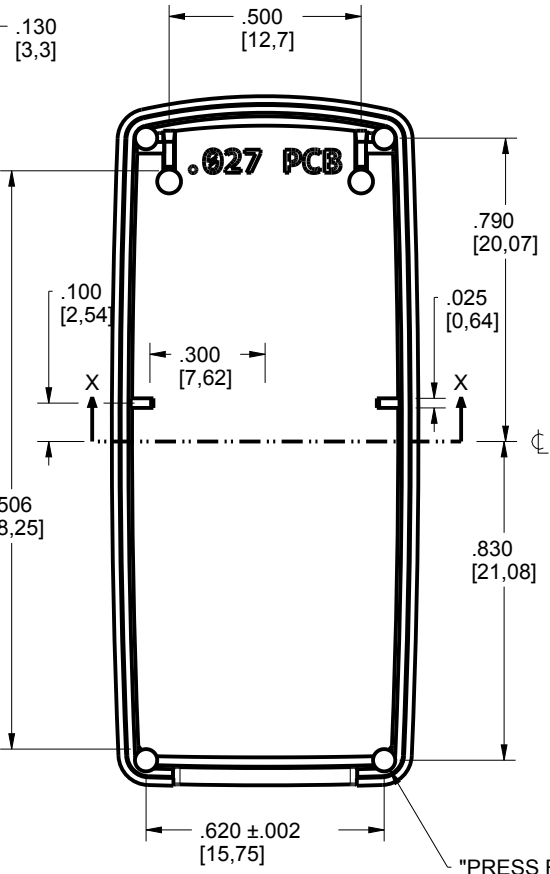
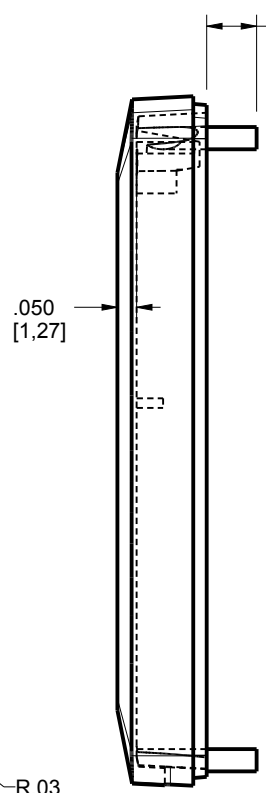

REFERENCE ONLY FEATURE.
NOT AVAILABLE IN ALL VERSIONS.

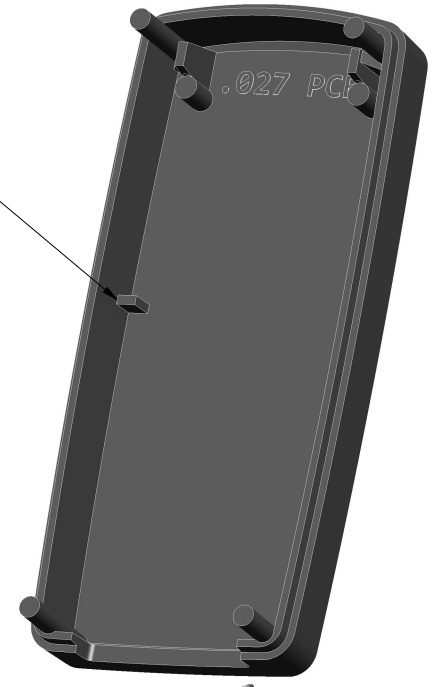

SCALE 2.000

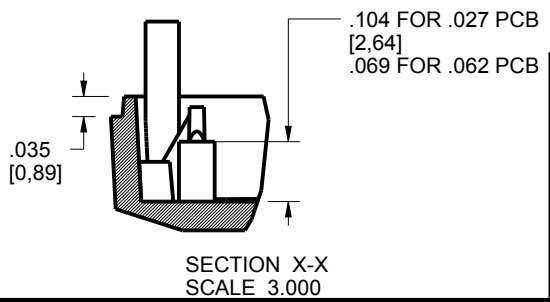
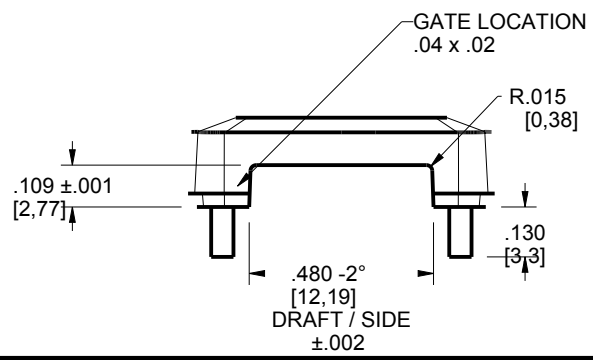

SECTION X-X
SCALE 3.000

TOLERANCES: UNLESS OTHERWISE SPECIFIED DIMENSIONS ARE IN U.S. INCHES.
X.XX = .015 X.XXXX = .001
X.XXX = .010 X.XX° = 1°

NEW AGE ENCLOSURES
Customer's Part No: 180804

APPROVAL	BY	DATE
CHECK		
ENG.		
SCALE	AS NOTED	
DRAWN BY	2005-May-04	
M BOYER		

NEW AGE ENCLOSURES
2240 South Thornburg Street Santa Maria, CA. 93455
ph. (805) 595-1310 fax (805) 595-1024
www.newageenclosures.com

STANDARD - USB DRIVE
PXX-180804XX-XXX

SIZE	DRAWING NAME	SHEET	REV.DOC
A	180804_R16_0	5 OF 8	16.0

P180804 PCB - CUSTOMER SUPPLIED

PCB SIZES ARE RECOMMENDATIONS ONLY. FINAL SIZES AND VERIFICATION OF ITS FIT ARE THE SOLE RESPONSIBILITY OF THE CUSTOMER.

SUGGESTED TYPE A USB PLUG CONNECTOR
 ACON, ADVANCED CONNECTEK INC.
 PN. C-UAR70-00-00
www.acon.com/en-global/product/detail/378

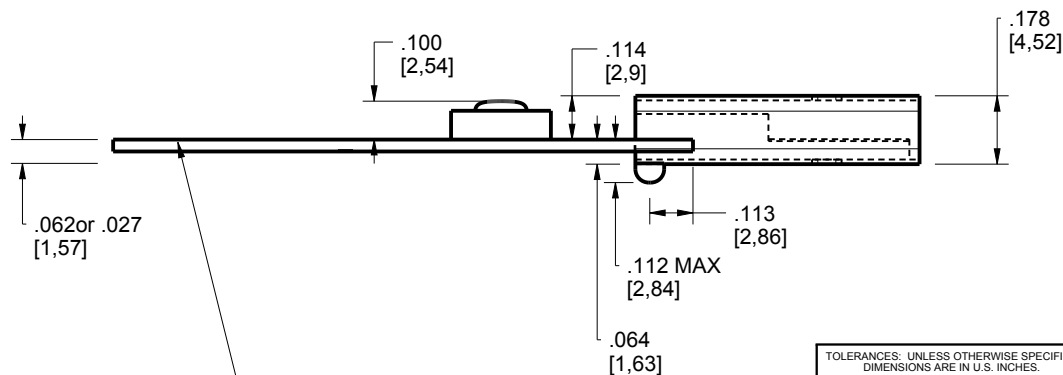
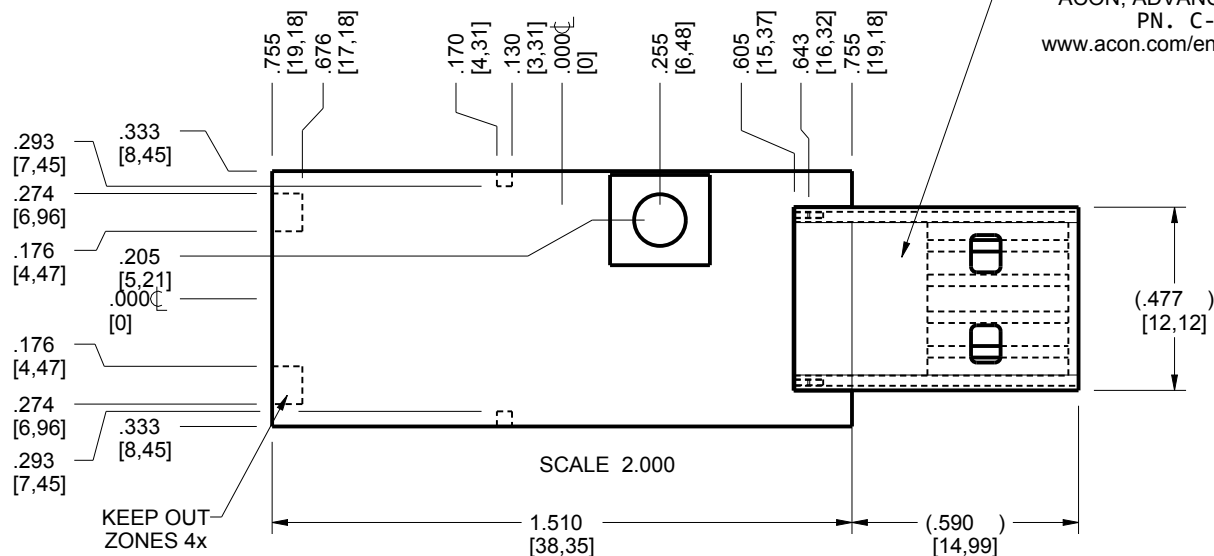

"STANDARD" 180804-S CONFIGURATION
 CAN ACCOMODATE 0.027" to 0.031" PCB.
 OR
 180804-62 CONFIGURATION
 CAN ACCOMODATE 0.062" PCB.

TOLERANCES: UNLESS OTHERWISE SPECIFIED
 DIMENSIONS ARE IN U.S. INCHES.
 X.XX = .015 X.XXXX = .001
 X.XXX = .010 X.X' = 1°

NEW AGE ENCLOSURES	
Customer's Part No: 180804	
APPROVAL	BY DATE
CHECK	
ENG.	
SCALE	AS NOTED
DRAWN BY	2005-May-04
M BOYER	

NEW AGE ENCLOSURES
 2240 South Thornburg Street Santa Maria, CA. 93455
 ph. (805) 595-1310 fax (805) 595-1024
www.newageenclosures.com

**STANDARD - USB DRIVE
 PXX-180804XX-XXX**

SIZE	DRAWING NAME	SHEET	REV.DOC
A	180804_R16_0	6 OF 8	16.0

OPTIONAL BUTTON

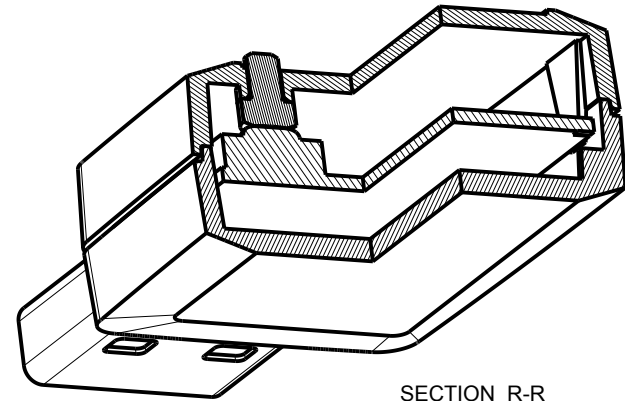
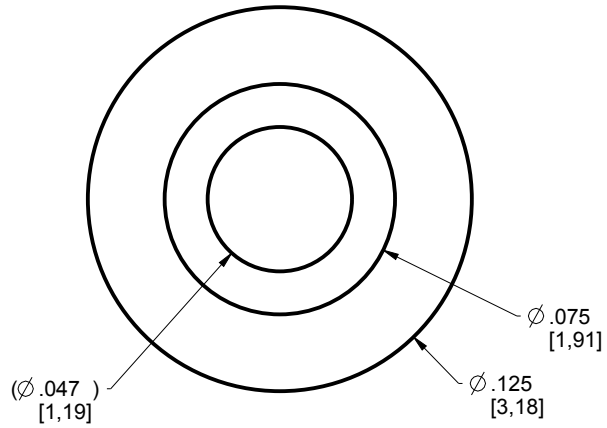

SECTION R-R
SCALE 2.500

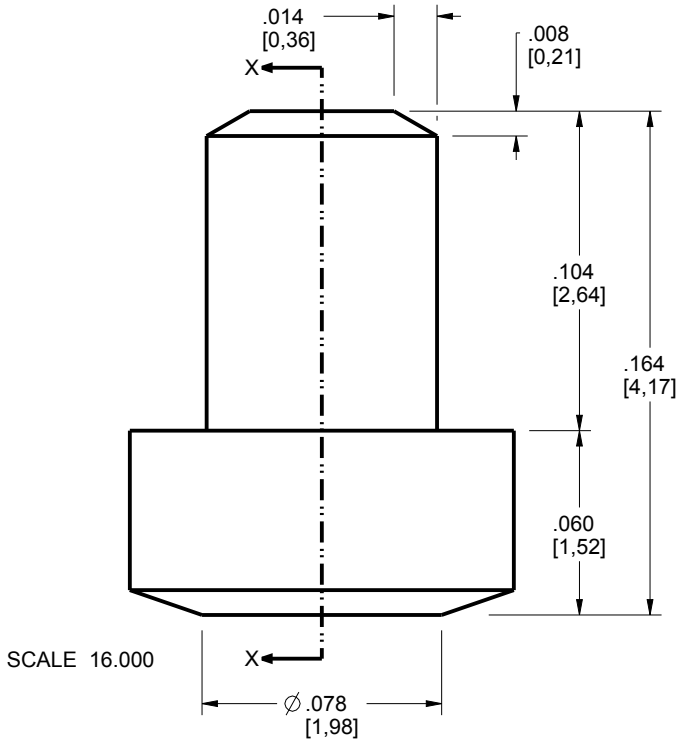

SCALE 16.000

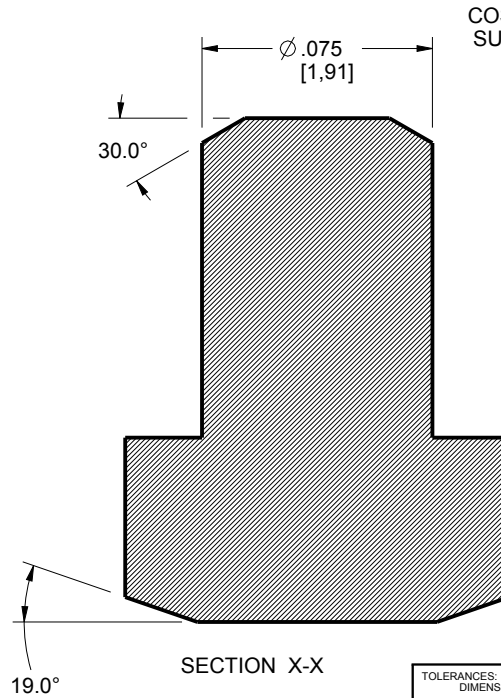

SECTION X-X

COSMETIC SURFACE

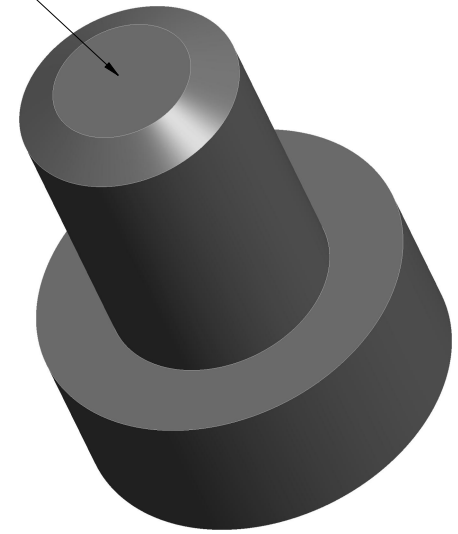

SCALE 16.000

TOLERANCES: UNLESS OTHERWISE SPECIFIED
DIMENSIONS ARE IN U.S. INCHES.

X.XX = .015 X.XXXX = .001
X.XXX = .010 X.X° = 1°

NEW AGE ENCLOSURES

NEW AGE ENCLOSURES
2240 South Thornburg Street Santa Maria, CA. 93455
ph. (805) 595-1310 fax (805) 595-1024

www.newageenclosures.com

Customer's Part No: 180804

APPROVAL BY DATE

CHECK

ENG.

SCALE AS NOTED

DRAWN BY M BOYER 2005-May-04

STANDARD - USB DRIVE
PXX-180804XX-XXX

SIZE A DRAWING NAME 180804_R16_0

SHEET 7 OF 8 REV.DOC 16.0

2nd OPERATION DETAILS

NEW AGE ENCLOSURES DELIVERS YOUR ENCLOSURE MARKET-READY WITH IN-HOUSE
CNC MACHINING, PAD PRINTING, ASSEMBLY, AND FULFILLMENT.
ALL SURFACES AND AREAS ARE AVAILABLE FOR CNC ALTERATION BY NEW AGE ENCLOSURES
CALL (805) 595-1310 FOR PRICING AND SCHEDULE.
THE INSIDE RADIUS OF ANY MACHINED FEATURES SHOULD BE NO SMALLER THAN .031"

MOLDED TYPE A
USB OPENING

MOLDED TYPE A
USB OPENING

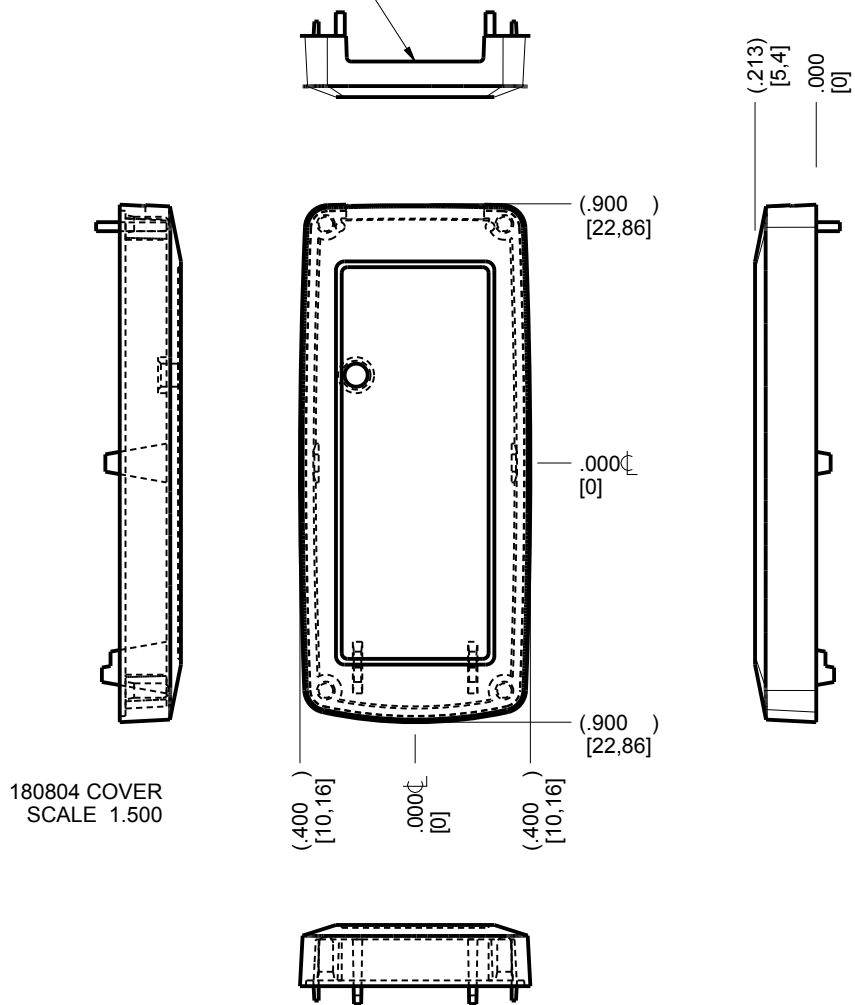

180804 COVER
SCALE 1.500

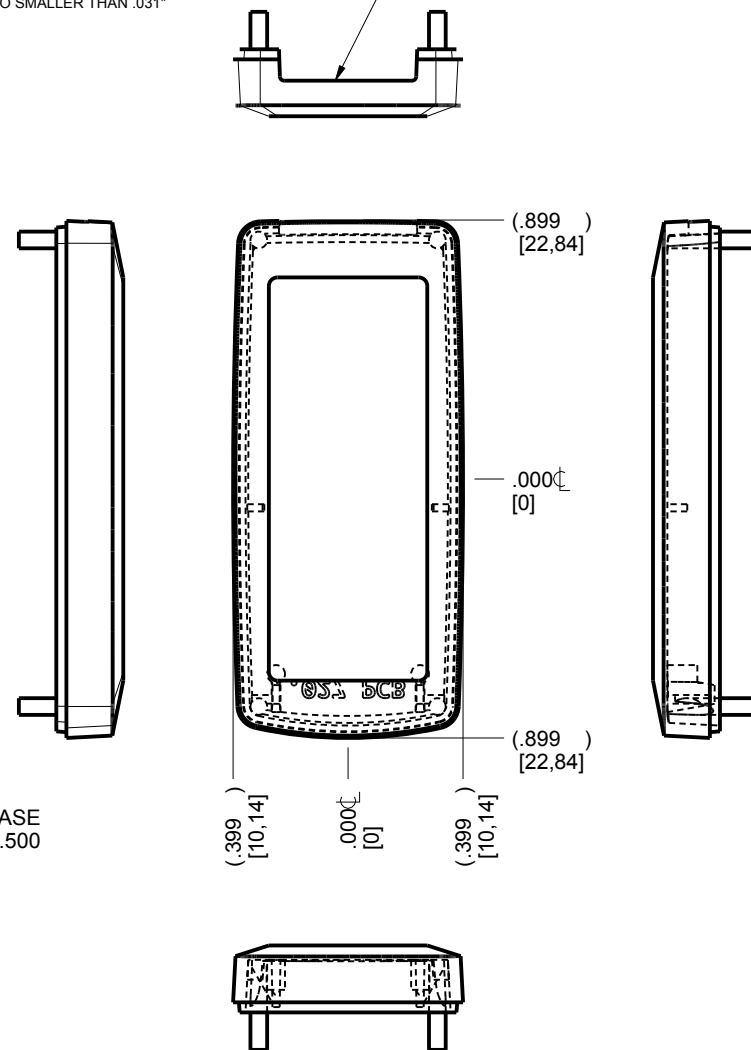

180804 BASE
SCALE 1.500

PXX-180804U-XXX COVER - ABS, BLACK

STEP NO	DESCRIPTION	CUTTER	FIXTURE	ORIENTATION	PROGRAM
1-C-C1	END CUT	T2 = .062" EM	100	2 UP LR- CENTER XY	o1001
2-C-C2	END CUT	T2 = .062" EM	100	2 UP LR- CENTER XY	o1002

PXX-180804U-XXX BASE - ABS, BLACK

STEP NO	DESCRIPTION	CUTTER	FIXTURE	ORIENTATION	PROGRAM
3-B-C1	END CUT	T2 = .062" EM	100	2 UP LR- CENTER XY	o1003
4-B-C2	END CUT	T2 = .062" EM	100	2 UP LR- CENTER XY	o1004

TOLERANCES: UNLESS OTHERWISE SPECIFIED
DIMENSIONS ARE IN U.S. INCHES.
X.XX = .015 X.XXXX = .001
X.XXX = .010 X.X° = 1°

NEW AGE ENCLOSURES
Customer's Part No: 180804

NEW AGE ENCLOSURES
2240 South Thornburg Street Santa Maria, CA. 93455
ph. (805) 595-1310 fax (805) 595-1024
www.newageenclosures.com

APPROVAL	BY	DATE
CHECK		
ENG.		
SCALE	AS NOTED	
DRAWN BY	M BOYER	
	2005-May-04	

STANDARD - USB DRIVE	
PXX-180804XX-XXX	
SIZE	DRAWING NAME
A	180804_R16_0
SHEET	REV.DOC
8 OF 8	16.0

Mouser Electronics

Authorized Distributor

Click to View Pricing, Inventory, Delivery & Lifecycle Information:

New Age Enclosures:

[P3A-180804UB](#) [P3A-180804U](#) [P1A-180804U](#) [P1A-180804S](#) [P1A-180804UB](#) [P3A-180804S](#) [P1A-18080462UB](#)
[P3A-18080462UB](#) [P1A-18080462U](#) [P3A-18080462U](#)

Компания «Океан Электроники» предлагает заключение долгосрочных отношений при поставках импортных электронных компонентов на взаимовыгодных условиях!

Наши преимущества:

- Поставка оригинальных импортных электронных компонентов напрямую с производств Америки, Европы и Азии, а так же с крупнейших складов мира;
- Широкая линейка поставок активных и пассивных импортных электронных компонентов (более 30 млн. наименований);
- Поставка сложных, дефицитных, либо снятых с производства позиций;
- Оперативные сроки поставки под заказ (от 5 рабочих дней);
- Экспресс доставка в любую точку России;
- Помощь Конструкторского Отдела и консультации квалифицированных инженеров;
- Техническая поддержка проекта, помощь в подборе аналогов, поставка прототипов;
- Поставка электронных компонентов под контролем ВП;
- Система менеджмента качества сертифицирована по Международному стандарту ISO 9001;
- При необходимости вся продукция военного и аэрокосмического назначения проходит испытания и сертификацию в лаборатории (по согласованию с заказчиком);
- Поставка специализированных компонентов военного и аэрокосмического уровня качества (Xilinx, Altera, Analog Devices, Intersil, Interpoint, Microsemi, Actel, Aeroflex, Peregrine, VPT, Syfer, Eurofarad, Texas Instruments, MS Kennedy, Miteq, Cobham, E2V, MA-COM, Hittite, Mini-Circuits, General Dynamics и др.);

Компания «Океан Электроники» является официальным дистрибьютором и эксклюзивным представителем в России одного из крупнейших производителей разъемов военного и аэрокосмического назначения «JONHON», а так же официальным дистрибьютором и эксклюзивным представителем в России производителя высокотехнологичных и надежных решений для передачи СВЧ сигналов «FORSTAR».



JONHON

«JONHON» (основан в 1970 г.)

Разъемы специального, военного и аэрокосмического назначения:

(Применяются в военной, авиационной, аэрокосмической, морской, железнодорожной, горно- и нефтедобывающей отраслях промышленности)

«FORSTAR» (основан в 1998 г.)

ВЧ соединители, коаксиальные кабели, кабельные сборки и микроволновые компоненты:

(Применяются в телекоммуникациях гражданского и специального назначения, в средствах связи, РЛС, а так же военной, авиационной и аэрокосмической отраслях промышленности).



Телефон: 8 (812) 309-75-97 (многоканальный)

Факс: 8 (812) 320-03-32

Электронная почта: ocean@oceanchips.ru

Web: <http://oceanchips.ru/>

Адрес: 198099, г. Санкт-Петербург, ул. Калинина, д. 2, корп. 4, лит. А