

## Parallel Input 8-channel Sink Driver with Flip-Flops

### FEATURES

- 8-channel Parallel Input Parallel Output
- Built-in Flip-Flops for latching Input data
- Supply Voltage  $V_{DD}=4.0$  to  $5.5V$
- Output Voltage  $V_{DS}=\text{up to } 40V$  (45V Rating)
- Output Current  $300mA(\text{DC}) / \text{ch.}$   
 $600mA(\text{Peak}) / \text{ch.}$
- Built-in Noise Filter (CLRb Pin)
- Protection Circuit OCP, TSD
- Output Slew Rate Control
- Operating Temperature  $T_{opr}=-40$  to  $125^{\circ}C$
- Package Outline SDIP22

### GENERAL DESCRIPTION

The NJW4828-A is 8-channel sink driver with 600mA output.

The input circuits have built-in flip-flops, and they can latch the input data signals by using the LP signal as trigger.

The CLRb input has built-in filter for noise immunity.

Supply voltage and input voltage correspond to 5V logic, maximum rating of output voltage is 45V.

The protection circuits have over current protection (OCP) and thermal shutdown (TSD).

Moreover, because it has built-in output slew rate adjustment function, it can be applied as EMI countermeasure.

### APPLICATION

- LED applications
- Relay and solenoid applications for industrial equipment

### TYPICAL APPLICATION

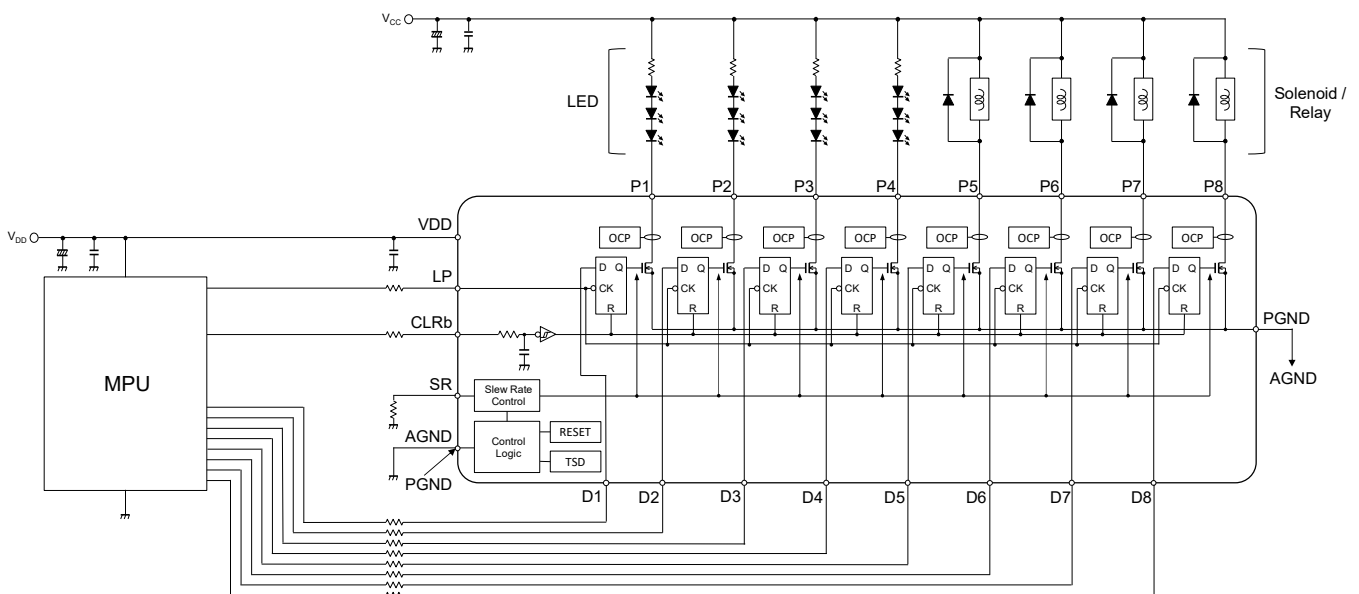

## ■BLOCK DIAGRAM

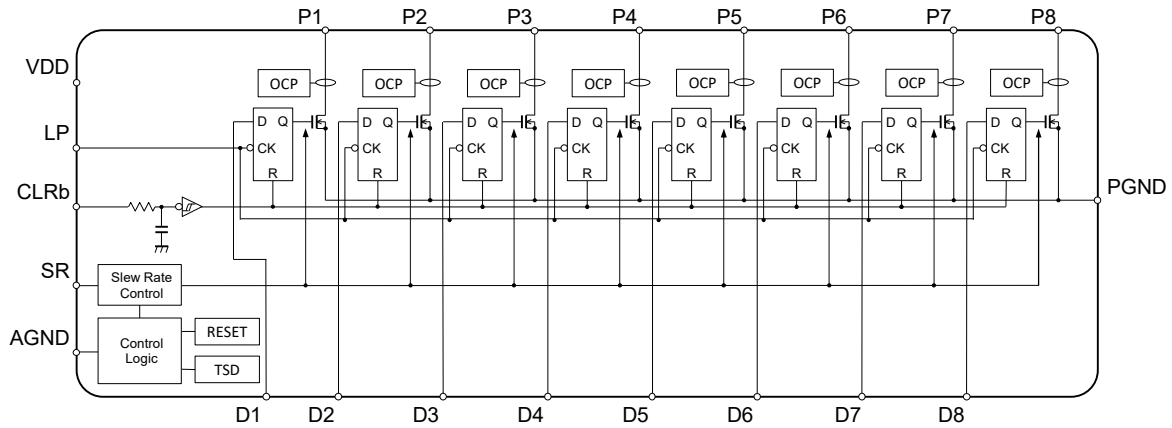

## ■PIN CONFIGURATION

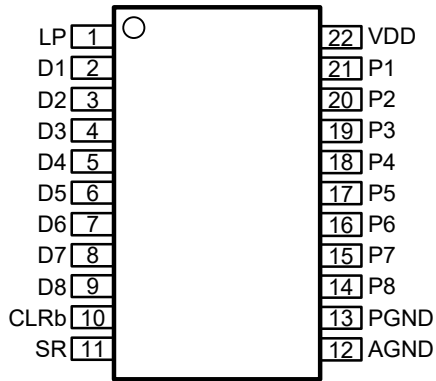

PIN NO.	SYMBOL	I/O	DESCRIPTION
1	LP	I	Latch Signal Input Pin
2	D1	I	Parallel Data Input Pin
3	D2	I	
4	D3	I	
5	D4	I	
6	D5	I	
7	D6	I	
8	D7	I	
9	D8	I	
10	CLRb	I	Clear Signal Input Pin
11	SR	-	Output Slew Rate Setting Pin
12	AGND	-	Control Block Ground Pin
13	PGND	-	Output Block Ground Pin
14	P8	O	Parallel Output Pin
15	P7	O	
16	P6	O	
17	P5	O	
18	P4	O	
19	P3	O	
20	P2	O	
21	P1	O	
22	VDD	-	Power Supply Pin

## ■PRODUCT NAME INFORMATION

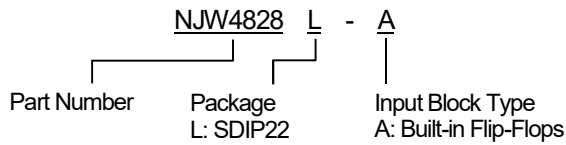

## ■ORDERING INFORMATION

PRODUCT NAME	PACKAGE OUTLINE	RoHS	HALOGEN-FREE	TERMINAL FINISH	MARKING	WEIGHT (mg)	MOQ(pcs)
NJW4828L-A	SDIP22	yes	-	Sn2Bi	NJW4828LA	1080	1000

## ■ABSOLUTE MAXIMUM RATINGS

PARAMETER	SYMBOL	RATINGS	UNIT	NOTE
Supply Voltage	$V_{DD}$	-0.3 to +7	V	VDD Pin
Output Pin Voltage	$V_{DS}$	-0.3 to +45	V	P1 to P8 Pin
Input Pin Voltage	$V_{IN}$	-0.3 to $V_{DD}$	V	D1 to D8, LP, CLRb Pin
Output Current	$I_{DS}$	600	mA	P1 to P8 Pin
Power Dissipation ( $T_a=25^\circ\text{C}$ ) SDIP22	$P_D$	1.5 <sup>(1)</sup>	W	
		2.1 <sup>(2)</sup>		
Junction Temperature Range	$T_j$	-40 to +150	$^\circ\text{C}$	
Operating Temperature Range	$T_{opr}$	-40 to +125	$^\circ\text{C}$	
Storage Temperature Range	$T_{stg}$	-50 to +150	$^\circ\text{C}$	

(1): Mounted on glass epoxy board. (101.5×114.5×1.6mm: based on EIA/JEDEC standard, 2Layers FR-4)

(2): Mounted on glass epoxy board. (101.5×114.5×1.6mm: NJRC original board, 2Layers FR-4, 2Layer side Cu area 99.5×99.5mm)

## ■RECOMMENDED OPERATING CONDITIONS

PARAMETER	SYMBOL	RATINGS	UNIT
Supply Voltage	$V_{DD}$	4.0 to 5.5	V
Output Pin Voltage	$V_{DS}$	0 to 40	V
Output Current <sup>(3)</sup>	$I_{DS}$	0 to 300	mA

(3): Caution that the total power consumption of P1 to P8 does not exceed the power dissipation of rating.

## ■ ELECTRICAL CHARACTERISTICS (DC Parameter)

(Unless otherwise noted,  $V_{DD}=5V$ ,  $R_{SR}=500k\Omega$ ,  $T_a=25^\circ C$ )

PARAMETER	SYMBOL	TEST CONDITION	MIN.	TYP.	MAX.	UNIT
Quiescent Current 1	$I_{Q1}$	All outputs OFF	-	1.4	2.8	mA
Quiescent Current 2	$I_{Q2}$	All outputs ON	-	1.6	3.2	mA
H level Input Voltage	$V_{IH}$	LP, CLRb, D1 to D8 Pin	$0.7V_{DD}$	-	$V_{DD}$	V
L level Input Voltage	$V_{IL}$	LP, CLRb, D1 to D8 Pin	0	-	$0.3V_{DD}$	V
H level Input Current	$I_{IH}$	$V_{DD}=5.5V$ , $V_{IN}=5.5V$ , LP, CLRb, D1 to D8 Pin	-	-	1	$\mu A$
L level Input Current	$I_{IL}$	$V_{DD}=5.5V$ , $V_{IN}=0V$ , LP, CLRb, D1 to D8 Pin	-	-	1	$\mu A$
Output ON Resistance	$R_{ON\_P}$	$V_{SR}=0V$ , $I_{DS}=100mA$ , P1 to P8 Pin	-	0.9	2.7	$\Omega$
Maximum Output Current	$I_{DMAX\_P}$	$V_{SR}=0V$ , P1 to P8 Pin	600	-	-	mA
Output Leak Current	$I_{LEAK\_P}$	$V_{DS}=40V$ , P1 to P8 Pin	-	-	1	$\mu A$
Thermal Shutdown Operating Temperature	$T_{TSD\_DET}$		-	170	-	$^\circ C$
Thermal Shutdown Recovery Temperature	$T_{TSD\_REV}$		-	150	-	$^\circ C$

## ■ ELECTRICAL CHARACTERISTICS (Switching Parameter)

(Unless otherwise noted,  $V_{DD}=5V$ ,  $V_{CC}=24V$ ,  $CL=30pF(P-PGND)$ ,  $R_L=240\Omega(P-V_{CC})$ ,  $T_a=25^\circ C$ )

PARAMETER	SYMBOL	TEST CONDITION	MIN.	TYP.	MAX.	UNIT
Output "H-L" Transition Time	$t_{THL}$	$R_{SR}=500k\Omega$	-	2.5	-	$\mu s$
Output "L-H" Transition Time	$t_{TLH}$	$R_{SR}=500k\Omega$	-	1.8	-	$\mu s$
Output "H-L" Propagation Delay Time (LP-P)	$t_{pdHL\_LP}$	$V_{SR}=0V$	-	0.2	-	$\mu s$
Output "L-H" Propagation Delay Time (LP-P)	$t_{pdLH\_LP}$	$V_{SR}=0V$	-	0.9	-	$\mu s$
D Setup Time for LP	$t_{SU\_D}$		30	-	-	ns
D Hold Time for LP	$t_{HD\_D}$		15	-	-	ns
LP "H" Pulse Width	$t_{W\_LP}$		90	-	-	ns
CLRb "L" Pulse Width	$t_{W\_CLRb}$		5	-	-	$\mu s$

## ■ THERMAL CHARACTERISTICS

PARAMETER	SYMBOL	VALUE	UNIT
Junction to ambient thermal resistance	$\theta_{ja}$	83 <sup>(4)</sup>	$^\circ C/W$
		59 <sup>(5)</sup>	
Junction to top of package characterization parameter	$\psi_{jt}$	23 <sup>(4)</sup>	$^\circ C/W$
		22 <sup>(5)</sup>	

(4): Mounted on glass epoxy board. (101.5×114.5×1.6mm: based on EIA/JEDEC standard, 2Layers FR-4)

(5): Mounted on glass epoxy board. (101.5×114.5×1.6mm: NJRC original board, 2Layers FR-4, 2Layer side Cu area 99.5×99.5mm)

## APPLICATION NOTE / GLOSSARY

### ● Truth Table

INPUT			P OUTPUT (with pull-up resistor)	OPERATION
CLRb	LP	D		
L	X	X	All OFF (H)	Reset all data of the input circuit and protection circuit
H	↑	L	OFF (H)	Set "L" to the input latch circuit
	↑	H	ON (L)	Set "H" to the input latch circuit
	↓	X	P0	Input data can't be imported

↑ : Change from "L" to "H"    H : High Level    X : Don't Care

↓ : Change from "H" to "L"    L : Low Level

P0 : The P output level just before input condition in the above table

### ● Timing Chart / Timing Definition

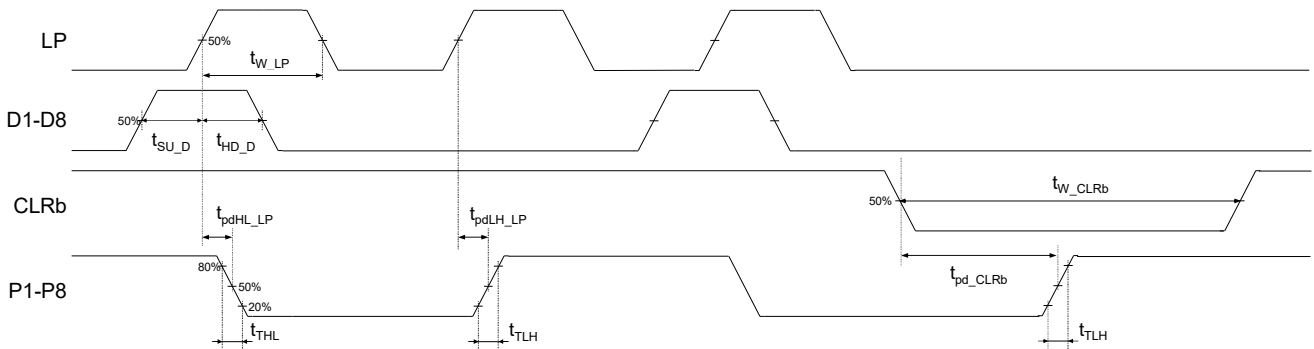

### ● Over Current Protection Circuit (OCP)

Overcurrent detection operates for each P1 - P8 output.

When overcurrent is detected, the corresponding P output is turned OFF.

After overcurrent is detected, when data is reset or passage of internal recovery time (10 $\mu$ s typ.), it returns to normal operation.

In the condition of the P output is already overcurrent detected and turned off, if another P output is detected continuously, all the recovery timing of the corresponding P outputs will be all taken over.

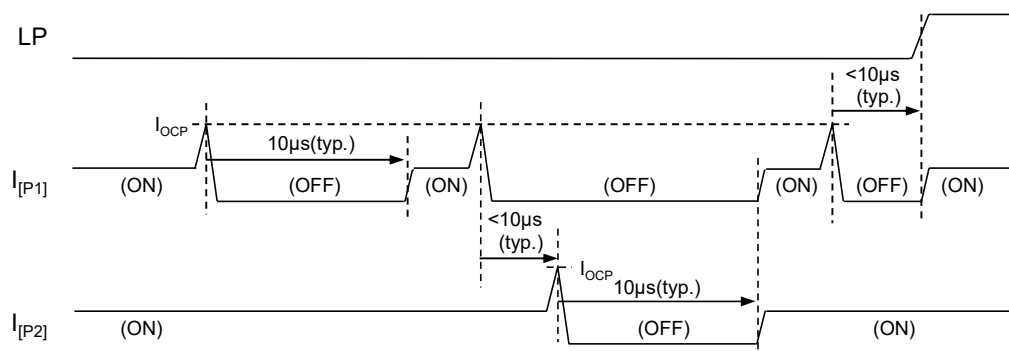

### ● Thermal Shutdown Circuit (TSD)

When the junction temperature inside the IC exceeds  $T_{TSD\_DET}$ , all P outputs are turned OFF.

When the internal junction temperature drops to  $T_{TSD\_REV}$  or less, it returns to normal operation state.

Input signals other than CLRb are not accepted while the thermal shutdown circuit is operating.

●Power ON Reset Function

The power supply pin has built-in power on reset function. When the  $V_{DD}$  voltage below  $V_{DPOR}$  (typ.), all outputs are turned off and all internal states are initialized.

When the  $V_{DD}$  voltage exceeds  $V_{RPOR}$  (typ.), it operates normally, but the  $V_{DD}$  voltage should be used within the recommended operating voltage range ( $V_{DD}=4.0V$  to  $5.5V$ )

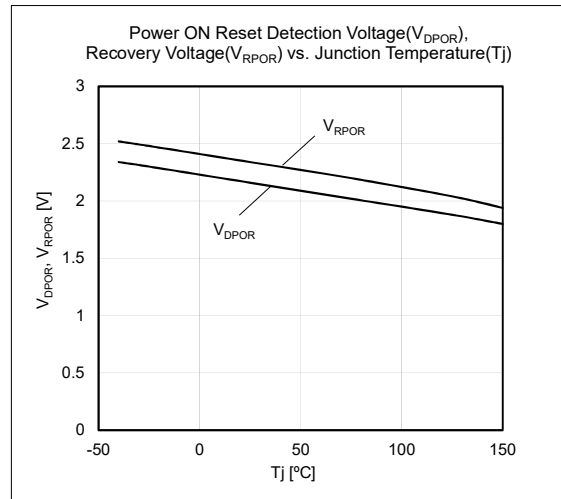

●Output Slew Rate Setting Function (SR Pin)

The SR function can set the rise time and fall time of the gate voltage of the output FETs by connecting a pull-down resistor to the SR pin.

The pull-down resistance can be set from 0  $\Omega$  (connected to AGND) to 1M  $\Omega$ . It should not be open.

When this function is not used, connect the SR pin to AGND.

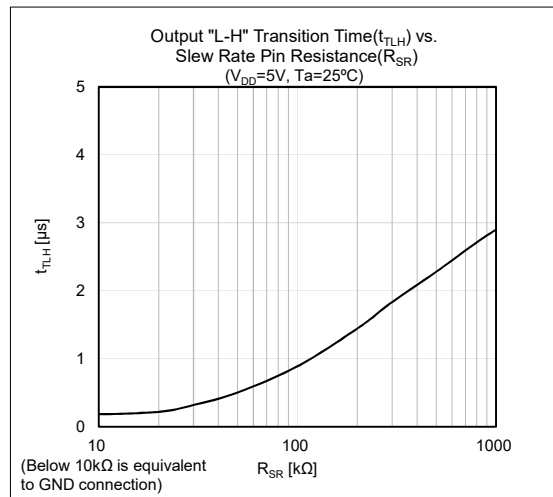
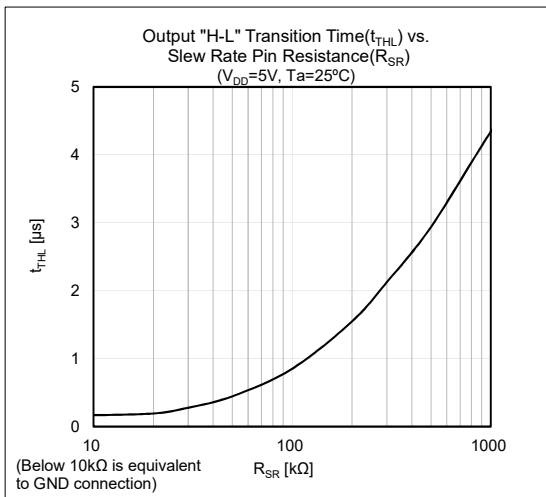

●Power Dissipation vs. Ambient Temperature

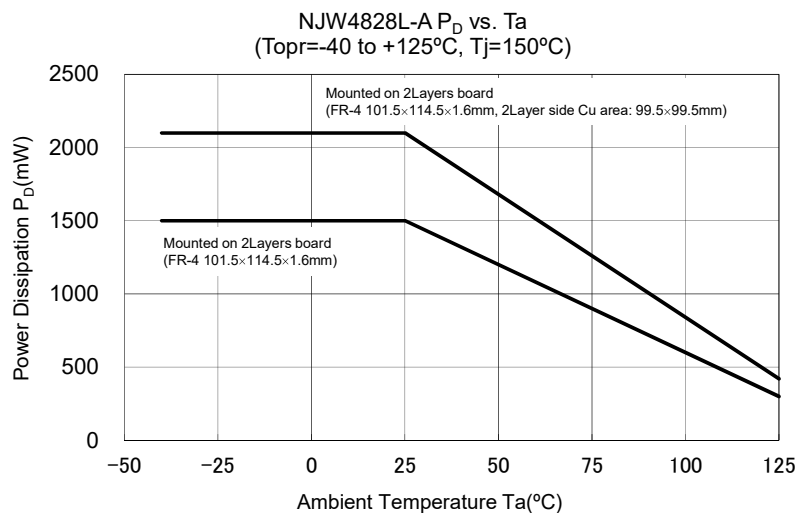

## ■ TYPICAL APPLICATION

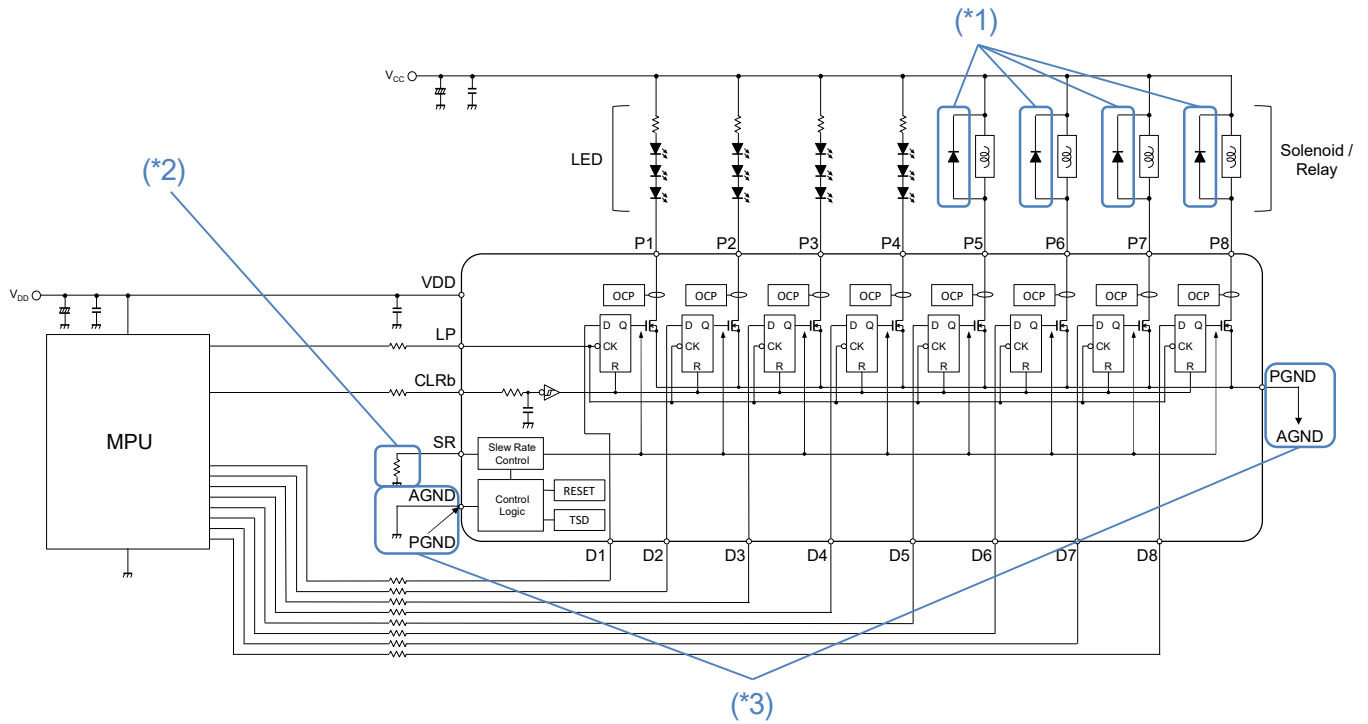

(\*1): The output pins don't have clamp circuits.

Therefore, when driving inductive loads such as solenoids and relays, connect a diode to the outside and secure path of recirculation current at turn-off.

(\*2): When SR function is not used, connect the SR pin to AGND and it should not be open.

(\*3): It should be wired the board so that there is no potential difference between AGND and PGND.

## ■ TYPICAL CHARACTERISTICS

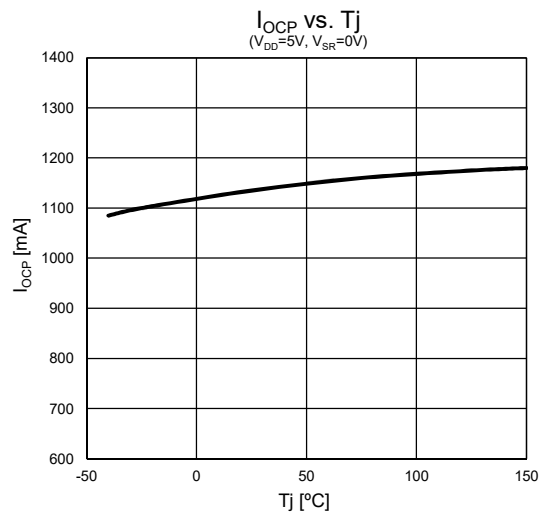
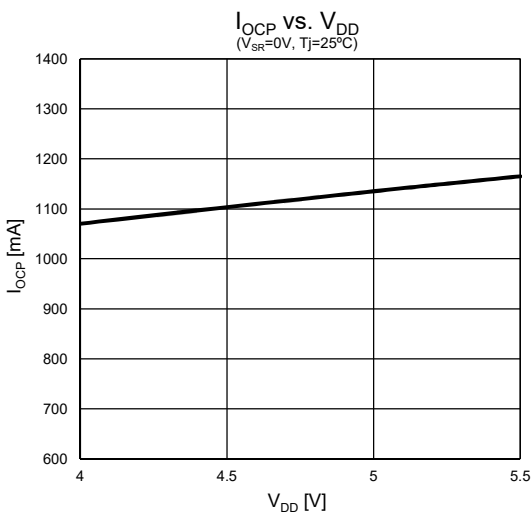
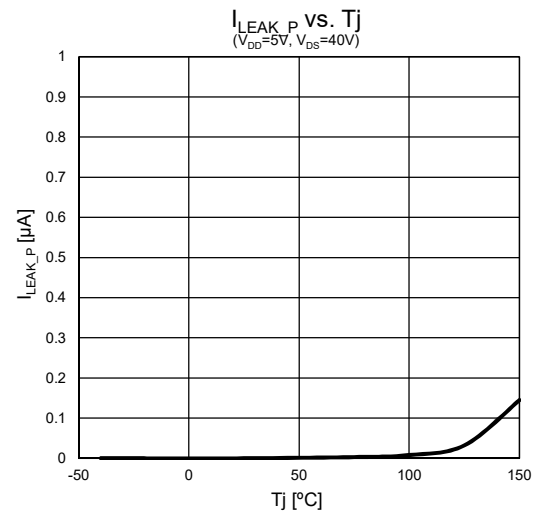
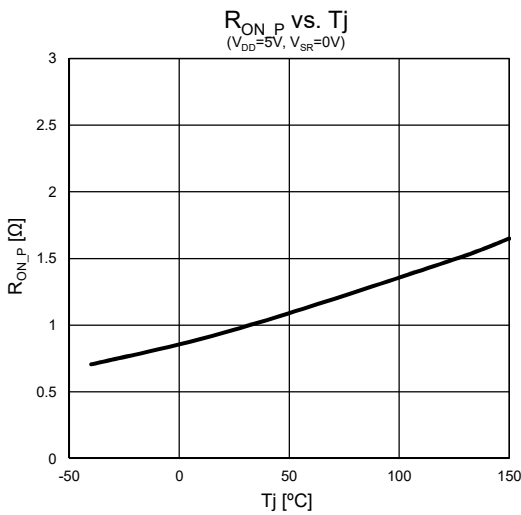
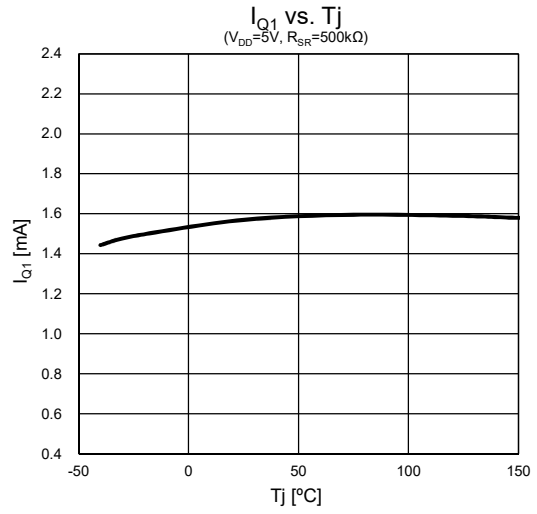
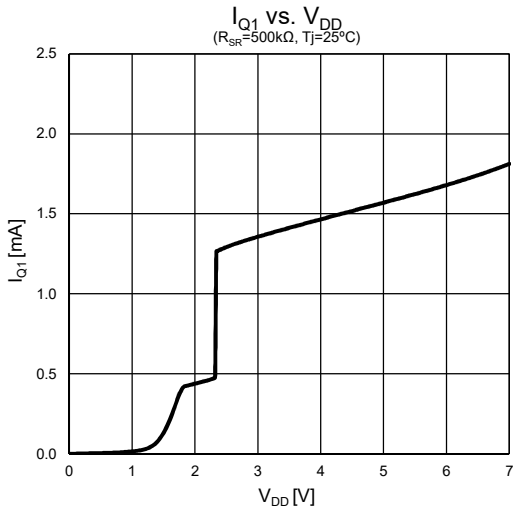



### ■PACKAGE DIMENSIONS

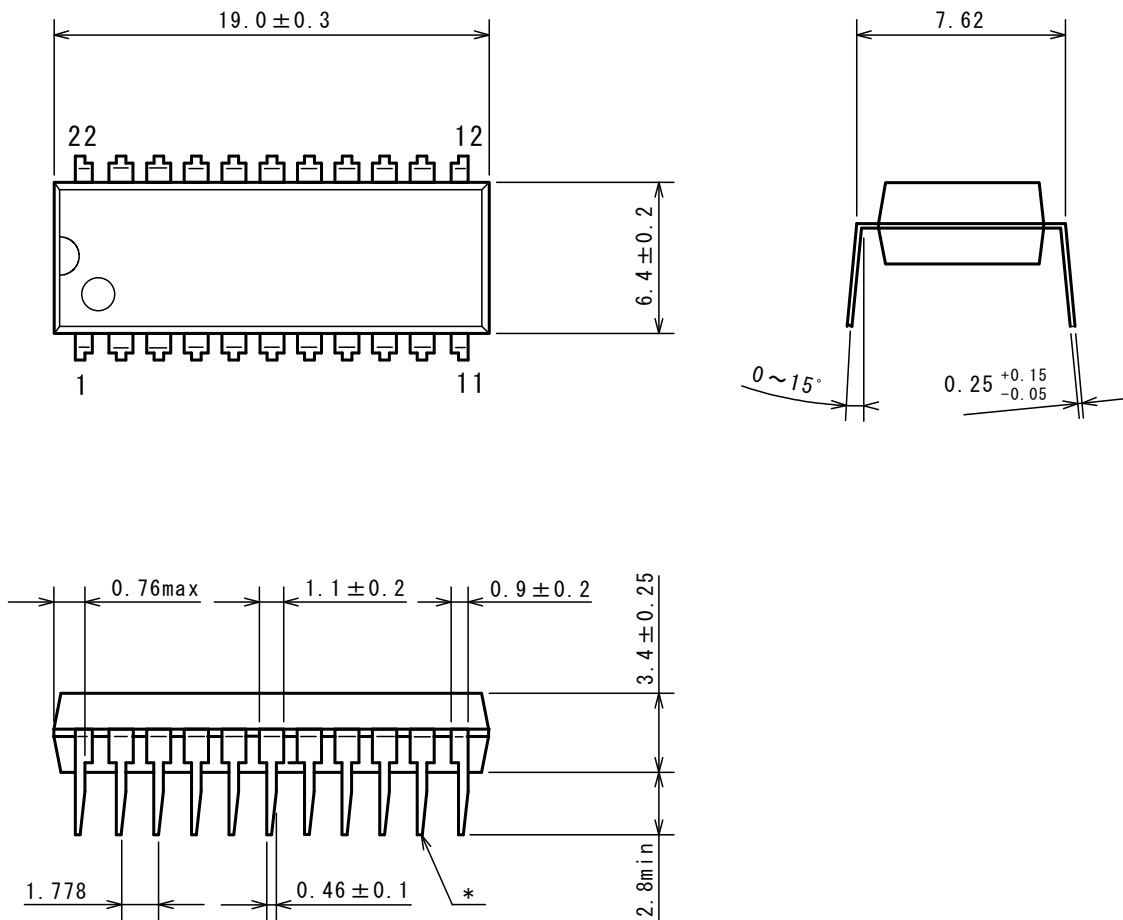

\*There are device mixed with taper on the right and the left.

### PACKING SPEC

#### STICK STATE

Stick (Max. 25pcs)  
 Material: PVC  
 Stopper: Stick pin

Cross section

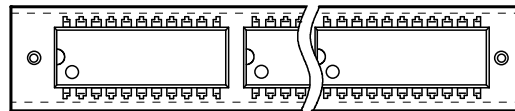
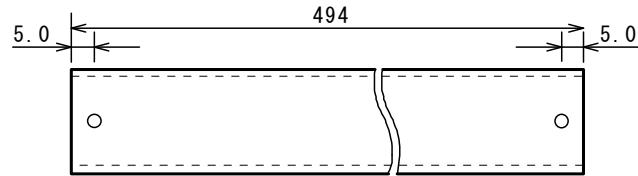
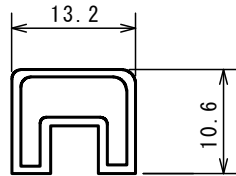

Direction of 1pin.

#### PACKING STATE

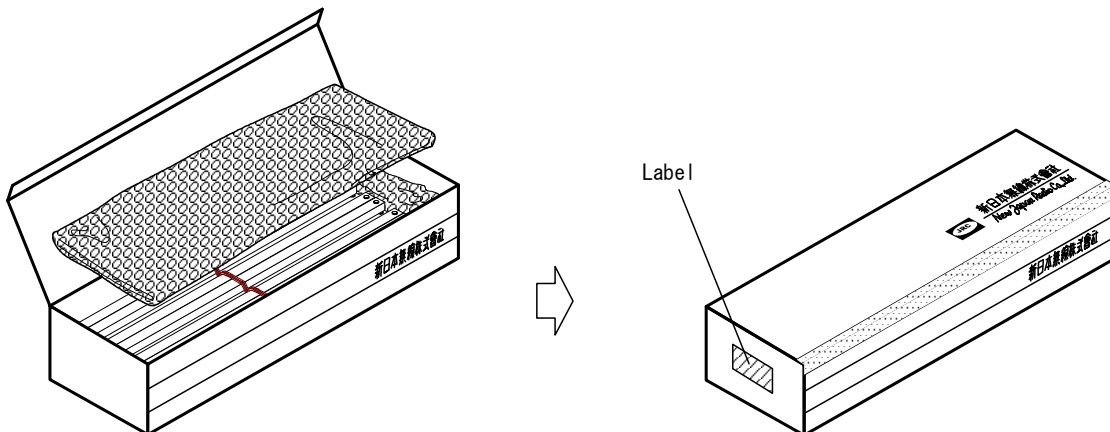

## RECOMMENDED MOUNTING METHOD

### FLOW SOLDERING METHOD

\*flow soldering procedure

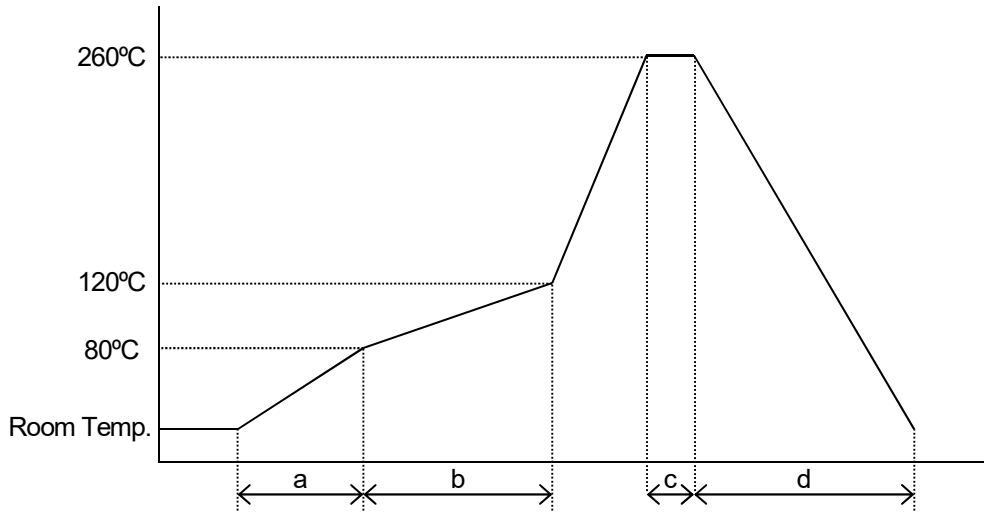

- a: Temperature ramping rate : 1 to 7°C/s
- b: Pre-heating temperature : 80 to 120°C  
Pre-heating time : 60 to 120s
- c: Peak temperature : not exceeding 260°C  
Peak time : within 10s
- d: Temperature ramping rate : 1 to 7°C/s

The temperature indicates at the lead terminal.

**■REVISION HISTORY**

Date	Revision	Changes
05.Jan.2018	Ver.1.0	New Release
21.Jun.2018	Ver.1.1	Corrected of GENERAL DESCRIPTION, APPLICATION NOTE (Power ON Reset Function) and ELECTRICAL CHARACTERISTICS (Test conditions of Output ON Resistance and Maximum Output Current).
23.Jul.2018	Ver.1.2	Corrected of APPLICATION NOTE (Truth Table)

## [ CAUTION ]

1. New JRC strives to produce reliable and high quality semiconductors. New JRC's semiconductors are intended for specific applications and require proper maintenance and handling. To enhance the performance and service of New JRC's semiconductors, the devices, machinery or equipment into which they are integrated should undergo preventative maintenance and inspection at regularly scheduled intervals. Failure to properly maintain equipment and machinery incorporating these products can result in catastrophic system failures
2. The specifications on this datasheet are only given for information without any guarantee as regards either mistakes or omissions. The application circuits in this datasheet are described only to show representative usages of the product and not intended for the guarantee or permission of any right including the industrial rights.  
All other trademarks mentioned herein are property of their respective companies.
3. To ensure the highest levels of reliability, New JRC products must always be properly handled.  
The introduction of external contaminants (e.g. dust, oil or cosmetics) can result in failures of semiconductor products.
4. New JRC offers a variety of semiconductor products intended for particular applications. It is important that you select the proper component for your intended application. You may contact New JRC's Sale's Office if you are uncertain about the products listed in this catalog.
5. Special care is required in designing devices, machinery or equipment which demand high levels of reliability. This is particularly important when designing critical components or systems whose failure can foreseeably result in situations that could adversely affect health or safety. In designing such critical devices, equipment or machinery, careful consideration should be given to amongst other things, their safety design, fail-safe design, back-up and redundancy systems, and diffusion design.
6. The products listed in the catalog may not be appropriate for use in certain equipment where reliability is critical or where the products may be subjected to extreme conditions. You should consult our sales office before using the products in any of the following types of equipment.
  - Aerospace Equipment
  - Equipment Used in the Deep sea
  - Power Generator Control Equipment (Nuclear, Steam, Hydraulic)
  - Life Maintenance Medical Equipment
  - Fire Alarm/Intruder Detector
  - Vehicle Control Equipment (airplane, railroad, ship, etc.)
  - Various Safety devices
7. New JRC's products have been designed and tested to function within controlled environmental conditions. Do not use products under conditions that deviate from methods or applications specified in this catalog. Failure to employ New JRC products in the proper applications can lead to deterioration, destruction or failure of the products. New JRC shall not be responsible for any bodily injury, fires or accident, property damage or any consequential damages resulting from misuse or misapplication of its products. Products are sold without warranty of any kind, either express or implied, including but not limited to any implied warranty of merchantability or fitness for a particular purpose.
8. Warning for handling Gallium and Arsenic(GaAs) Products (Applying to GaAs MMIC, Photo Reflector). This Products uses Gallium(Ga) and Arsenic(As) which are specified as poisonous chemicals by law. For the prevention of a hazard, do not burn, destroy, or process chemically to make them as gas or power. When the product is disposed, please follow the related regulation and do not mix this with general industrial waste or household waste.
9. The product specifications and descriptions listed in this catalog are subject to change at any time, without notice.



# Mouser Electronics

Authorized Distributor

Click to View Pricing, Inventory, Delivery & Lifecycle Information:

[NJR:](#)

[NJW4828L-A](#)

Компания «Океан Электроники» предлагает заключение долгосрочных отношений при поставках импортных электронных компонентов на взаимовыгодных условиях!

Наши преимущества:

- Поставка оригинальных импортных электронных компонентов напрямую с производств Америки, Европы и Азии, а так же с крупнейших складов мира;
- Широкая линейка поставок активных и пассивных импортных электронных компонентов (более 30 млн. наименований);
- Поставка сложных, дефицитных, либо снятых с производства позиций;
- Оперативные сроки поставки под заказ (от 5 рабочих дней);
- Экспресс доставка в любую точку России;
- Помощь Конструкторского Отдела и консультации квалифицированных инженеров;
- Техническая поддержка проекта, помощь в подборе аналогов, поставка прототипов;
- Поставка электронных компонентов под контролем ВП;
- Система менеджмента качества сертифицирована по Международному стандарту ISO 9001;
- При необходимости вся продукция военного и аэрокосмического назначения проходит испытания и сертификацию в лаборатории (по согласованию с заказчиком);
- Поставка специализированных компонентов военного и аэрокосмического уровня качества (Xilinx, Altera, Analog Devices, Intersil, Interpoint, Microsemi, Actel, Aeroflex, Peregrine, VPT, Syfer, Eurofarad, Texas Instruments, MS Kennedy, Miteq, Cobham, E2V, MA-COM, Hittite, Mini-Circuits, General Dynamics и др.);

Компания «Океан Электроники» является официальным дистрибьютором и эксклюзивным представителем в России одного из крупнейших производителей разъемов военного и аэрокосмического назначения «JONHON», а так же официальным дистрибьютором и эксклюзивным представителем в России производителя высокотехнологичных и надежных решений для передачи СВЧ сигналов «FORSTAR».



## JONHON

«JONHON» (основан в 1970 г.)

Разъемы специального, военного и аэрокосмического назначения:

(Применяются в военной, авиационной, аэрокосмической, морской, железнодорожной, горно- и нефтедобывающей отраслях промышленности)

«FORSTAR» (основан в 1998 г.)

ВЧ соединители, коаксиальные кабели, кабельные сборки и микроволновые компоненты:

(Применяются в телекоммуникациях гражданского и специального назначения, в средствах связи, РЛС, а так же военной, авиационной и аэрокосмической отраслях промышленности).



Телефон: 8 (812) 309-75-97 (многоканальный)

Факс: 8 (812) 320-03-32

Электронная почта: [ocean@oceanchips.ru](mailto:ocean@oceanchips.ru)

Web: <http://oceanchips.ru/>

Адрес: 198099, г. Санкт-Петербург, ул. Калинина, д. 2, корп. 4, лит. А