

2.4 GHz High-Power and High-Gain Power Amplifier

SST12LP15A



Data Sheet

FEATURES:

- **High Gain:**
 - Typically 32 dB gain across 2.4–2.5 GHz over temperature 0°C to +85°C
- **High linear output power:**
 - >29 dBm P1dB
 - Please refer to “Absolute Maximum Stress Ratings” on page 4
 - Meets 802.11g OFDM ACPR requirement up to 25 dBm
 - Added EVM~4% up to 23 dBm for 54 Mbps 802.11g signal
 - Meets 802.11b ACPR requirement up to 25 dBm
- **High power-added efficiency/Low operating current for both 802.11g/b applications**
 - ~26%/300 mA @ $P_{OUT} = 24$ dBm for 802.11g
 - ~27%/350 mA @ $P_{OUT} = 25$ dBm for 802.11b
- **Built-in Ultra-low I_{REF} power-up/down control**
 - $I_{REF} \sim 2$ mA
- **Low idle current**
 - ~80 mA I_{CQ}
- **High-speed power-up/down**
 - Turn on/off time (10%-90%) <100 ns
 - Typical power-up/down delay with driver delay included <200 ns
- **High temperature stability**
 - ~1 dB gain/power variation between 0°C to +85°C
 - ~1 dB detector variation over 0°C to +85°C
- **Low shut-down current (~1 μ A)**
- **On-chip power detection**
- **25 dB dynamic range on-chip power detection**
- **Simple input/output matching**
- **Packages available**
 - 16-contact VQFN (3mm x 3mm)
- **All non-Pb (lead-free) devices are RoHS compliant**

APPLICATIONS:

- WLAN (IEEE 802.11g/b)
- Home RF
- Cordless phones
- 2.4 GHz ISM wireless equipment

PRODUCT DESCRIPTION

The SST12LP15A is a high-power and high-gain power amplifier based on the highly-reliable InGaP/GaAs HBT technology.

The SST12LP15A can be easily configured for high-power applications with superb power-added efficiency while operating over the 2.4-2.5 GHz frequency band. It typically provides 32 dB gain with 26% power-added efficiency @ $P_{OUT} = 24$ dBm for 802.11g and 27% power-added efficiency @ $P_{OUT} = 25$ dBm for 802.11b.

The SST12LP15A has excellent linearity, typically ~4% added EVM at 23 dBm output power which is essential for 54 Mbps 802.11g operation while meeting 802.11g spectrum mask at 25 dBm. SST12LP15A also has wide-range (>25 dB), temperature-stable (~1 dB over 85°C), single-ended/differential power detectors which lower users' cost on power control.

The power amplifier IC also features easy board-level usage along with high-speed power-up/down control. Ultra-low reference current (total $I_{REF} \sim 2$ mA) makes the SST12LP15A controllable by an on/off switching signal directly from the baseband chip. These features coupled with low operating current make the SST12LP15A ideal for the final stage power amplification in battery-powered 802.11g/b WLAN transmitter applications.

The SST12LP15A is offered in 16-contact VQFN package. See Figure 2 for pin assignments and Table 1 for pin descriptions.



2.4 GHz High-Power and High-Gain Power Amplifier SST12LP15A

Data Sheet

FUNCTIONAL BLOCKS

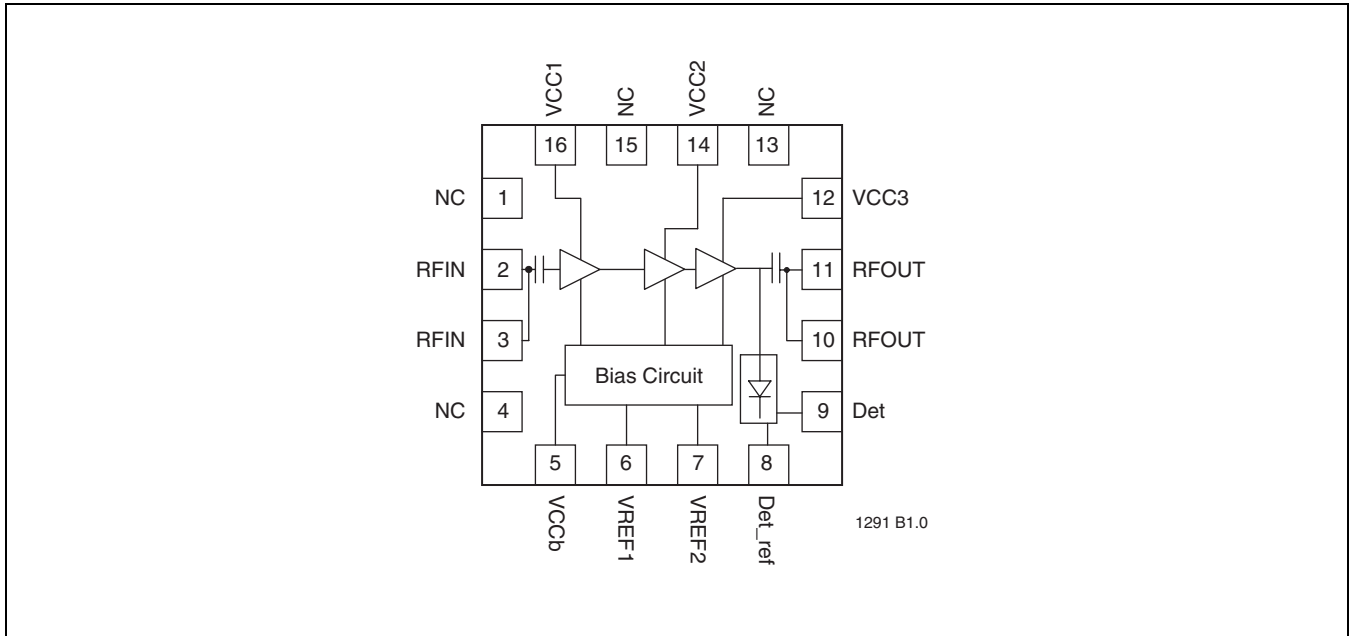

FIGURE 1: Functional Block Diagram6

2.4 GHz High-Power and High-Gain Power Amplifier SST12LP15A



Data Sheet

PIN ASSIGNMENTS

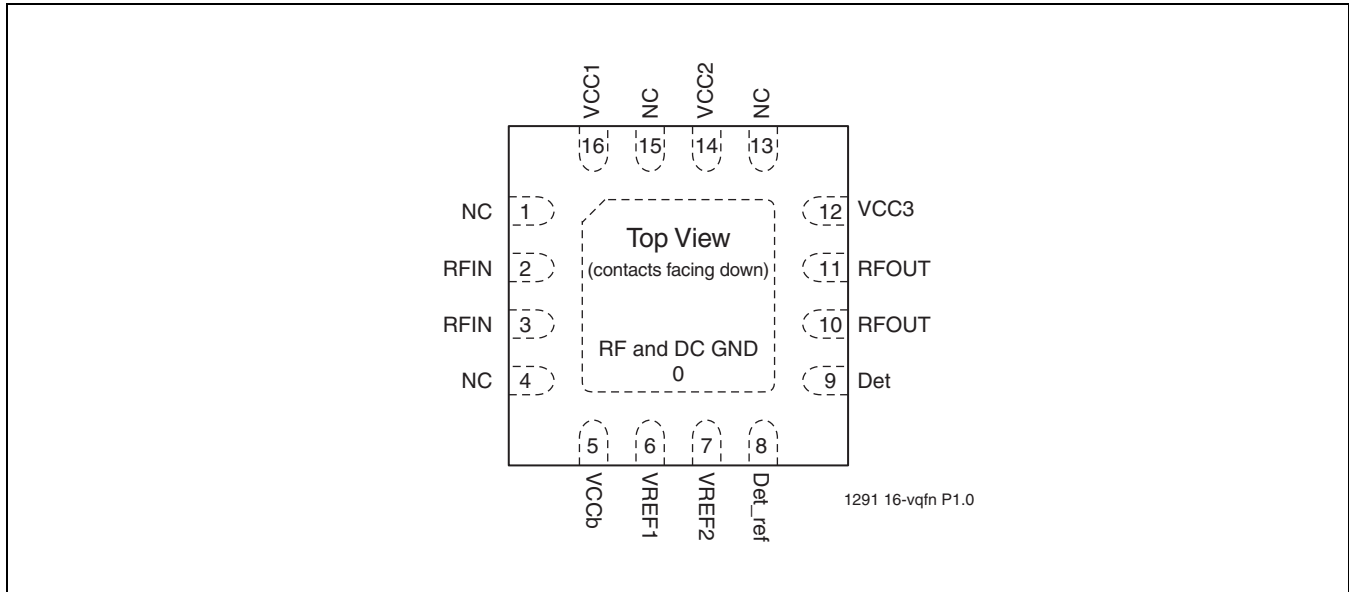

FIGURE 2: Pin Assignments for 16-contact VQFN

PIN DESCRIPTIONS

TABLE 1: Pin Description

Symbol	Pin No.	Pin Name	Type ¹	Function
GND	0	Ground		The center pad should be connected to RF ground with several low inductance, low resistance vias.
NC	1	No Connection		Unconnected pins.
RFIN	2		I	RF input, DC decoupled
RFIN	3		I	RF input, DC decoupled
NC	4	No Connection		Unconnected pins.
VCCb	5	Power Supply	PWR	Supply voltage for bias circuit
VREF1	6		PWR	1st and 2nd stage idle current control
VREF2	7		PWR	3rd stage idle current control
Det_ref	8		O	On-chip power detector reference
Det	9		O	On-chip power detector
RFOUT	10		O	RF output
RFOUT	11		O	RF output
VCC3	12	Power Supply	PWR	Power supply, 3rd stage
NC	13	No Connection		Unconnected pins.
VCC2	14	Power Supply	PWR	Power supply, 2nd stage
NC	15	No Connection		Unconnected pins.
VCC1	16	Power Supply	PWR	Power supply, 1st stage

1. I=Input, O=Output

T1.0 1291



2.4 GHz High-Power and High-Gain Power Amplifier SST12LP15A

Data Sheet

ELECTRICAL SPECIFICATIONS

The AC and DC specifications for the power amplifier interface signals. Refer to Table 2 for the DC voltage and current specifications. Refer to Figures 3 through 10 for the RF performance.

Absolute Maximum Stress Ratings (Applied conditions greater than those listed under “Absolute Maximum Stress Ratings” may cause permanent damage to the device. This is a stress rating only and functional operation of the device at these conditions or conditions greater than those defined in the operational sections of this data sheet is not implied. Exposure to absolute maximum stress rating conditions may affect device reliability.)

Input power to pins 2 and 3 (P_{IN})	+5 dBm
Average output power (P_{OUT}) ¹	+28 dBm
Supply Voltage at pins 5, 12, 14, 16 (V_{CC})	-0.3V to +4.6V
Reference voltage to pins 6 (V_{REF1}) and pin 7 (V_{REF2})	-0.3V to +3.6V
DC supply current (I_{CC})	500 mA
Operating Temperature (T_A)	-40°C to +85°C
Storage Temperature (T_{STG})	-40°C to +120°C
Maximum Junction Temperature (T_J)	+150°C
Surface Mount Solder Reflow Temperature	260°C for 10 seconds

1. Never measure with CW source. Pulsed single-tone source with <50% duty cycle is recommended. Exceeding the maximum rating of average output power could cause permanent damage to the device.

Operating Range

Range	Ambient Temp	V_{CC}
Industrial	-40°C to +85°C	3.3V

TABLE 2: DC Electrical Characteristics at 25°C

Symbol	Parameter	Min.	Typ	Max.	Unit
V_{CC}	Supply Voltage at pins 5, 12, 14, 16	3.0	3.3	4.2	V
I_{CC}	Supply Current				
	for 802.11g, 24 dBm		300		mA
	for 802.11b, 25 dBm		350		mA
I_{CQ}	Idle current for 802.11g to meet EVM<4% @ 23dBm		80		mA
I_{OFF}	Shut down current		1		μA
V_{REG1}	Reference Voltage for 1st and 2nd Stage, with 270Ω resistor	2.85	2.90	2.95	V
V_{REG2}	Reference Voltage for 3rd Stage, with 100Ω resistor	2.85	2.90	2.95	V

T2.1 1291



2.4 GHz High-Power and High-Gain Power Amplifier SST12LP15A

Data Sheet

TABLE 3: AC Electrical Characteristics for Configuration at 25°C

Symbol	Parameter	Min.	Typ	Max.	Unit
F _{L-U}	Frequency range in 802.11b/g applications (see Figure 11)	2400		2485	MHz
P _{OUT}	Output power @ PIN = -10 dBm 11b signals @ PIN = -10 dBm 11g signals		23 23		 dBm dBm
G	Small signal gain	31	32		dB
G _{VAR1}	Gain variation over each band (2400-2485 MHz)			±0.5	dB
G _{VAR2}	Gain ripple over channel (Gain variation over 20 MHz)		0.2		dB
ACPR	Meet 11b spectrum mask Meet 11g OFDM 54 MBPS spectrum mask	24 24	25 25		 dBm dBm
Added EVM	@ 23 dBm output with 11g OFDM 54 MBPS signal		3.5		%
2f, 3f, 4f, 5f	Harmonics at 22 dBm, without trapping capacitors			-40	dBc

T3.2 1291



2.4 GHz High-Power and High-Gain Power Amplifier SST12LP15A

Data Sheet

TYPICAL PERFORMANCE CHARACTERISTICS

Test Conditions: $V_{CC} = 3.3V$, $T_A = 25^\circ C$ Unless otherwise specified.

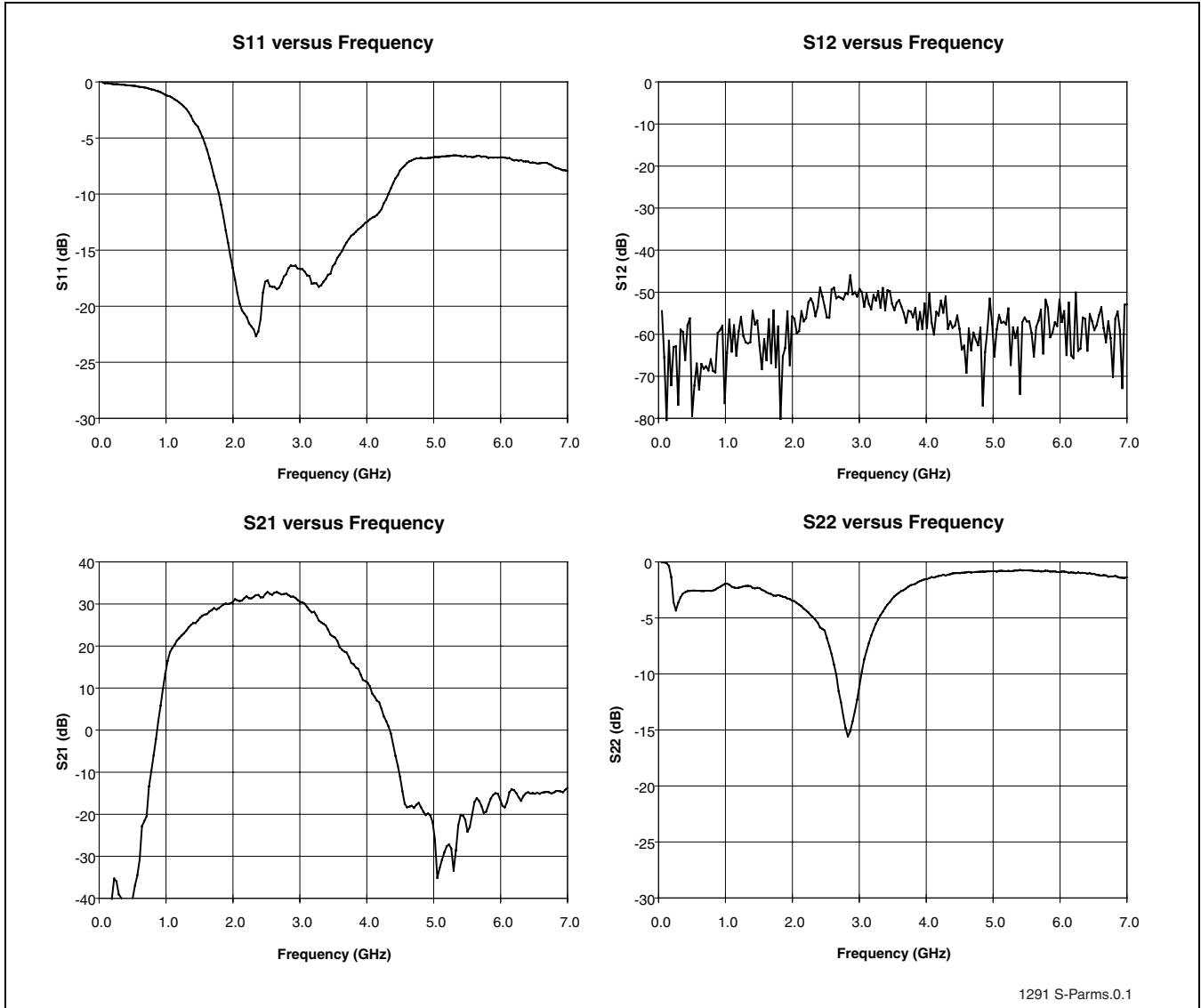

FIGURE 3: S-Parameters



TYPICAL PERFORMANCE CHARACTERISTICS

Test Conditions: $V_{CC} = 3.3V$, $T_A = 25^\circ C$, 54 Mbps 802.11g OFDM Signal

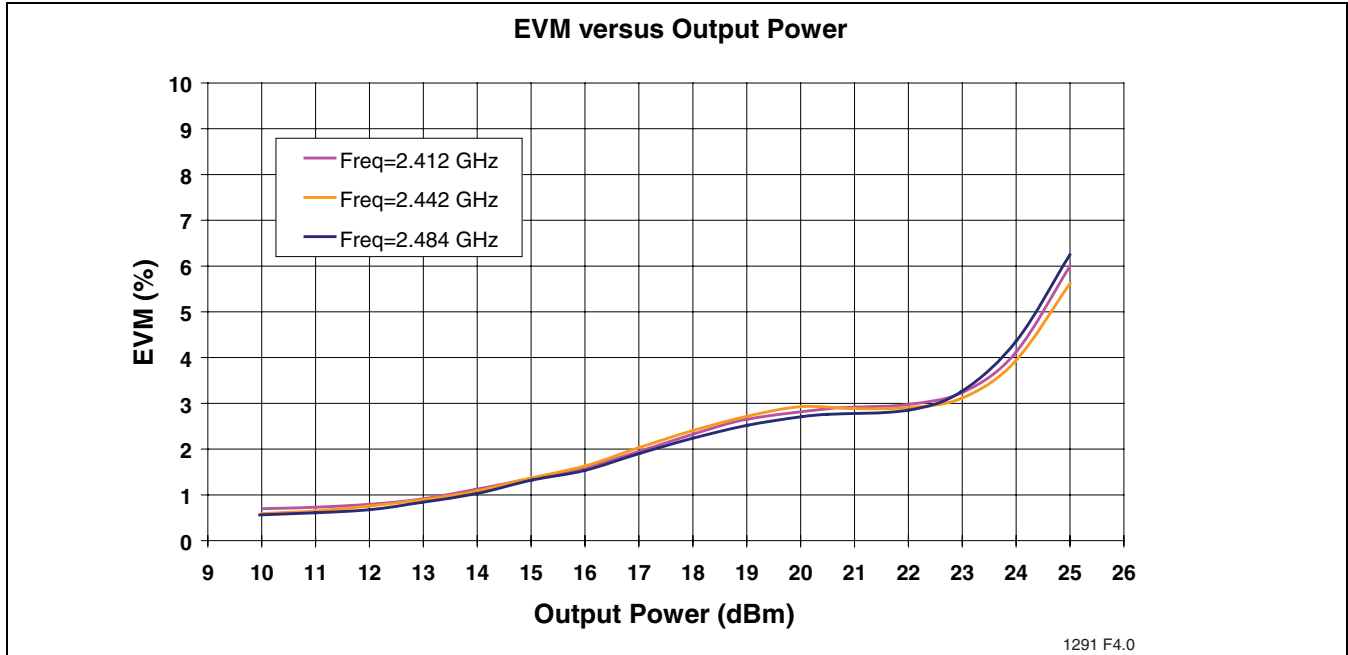

FIGURE 4: EVM versus Output Power

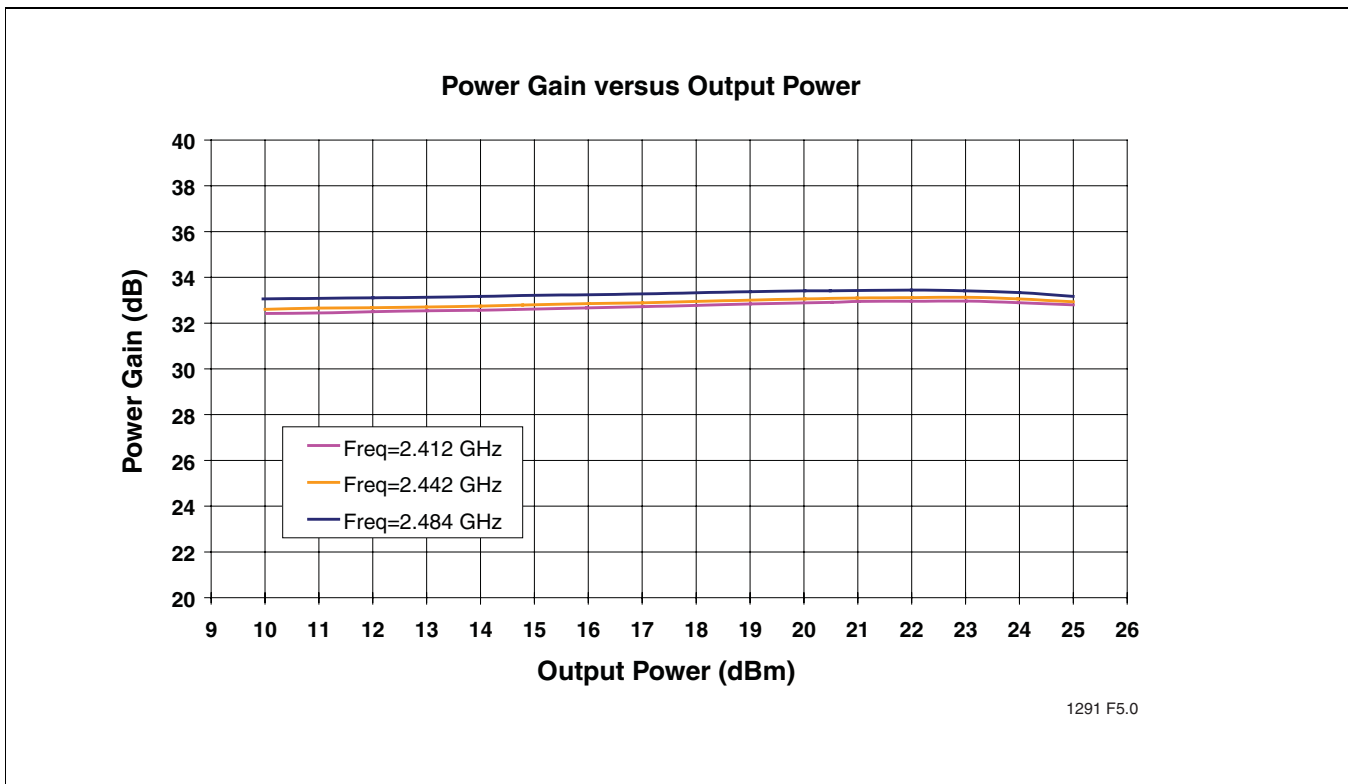

FIGURE 5: Power Gain versus Output Power



2.4 GHz High-Power and High-Gain Power Amplifier SST12LP15A

Data Sheet

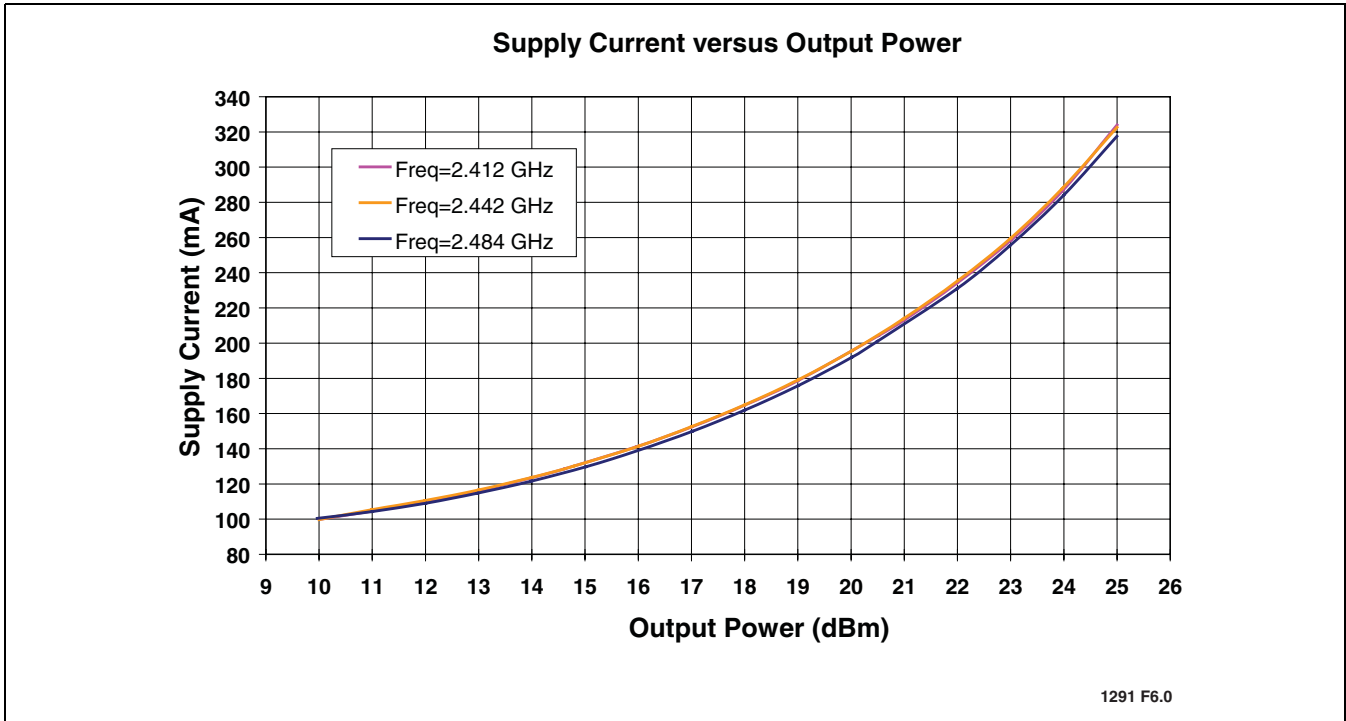

FIGURE 6: Total Current Consumption for 802.11g Operation versus Output Power

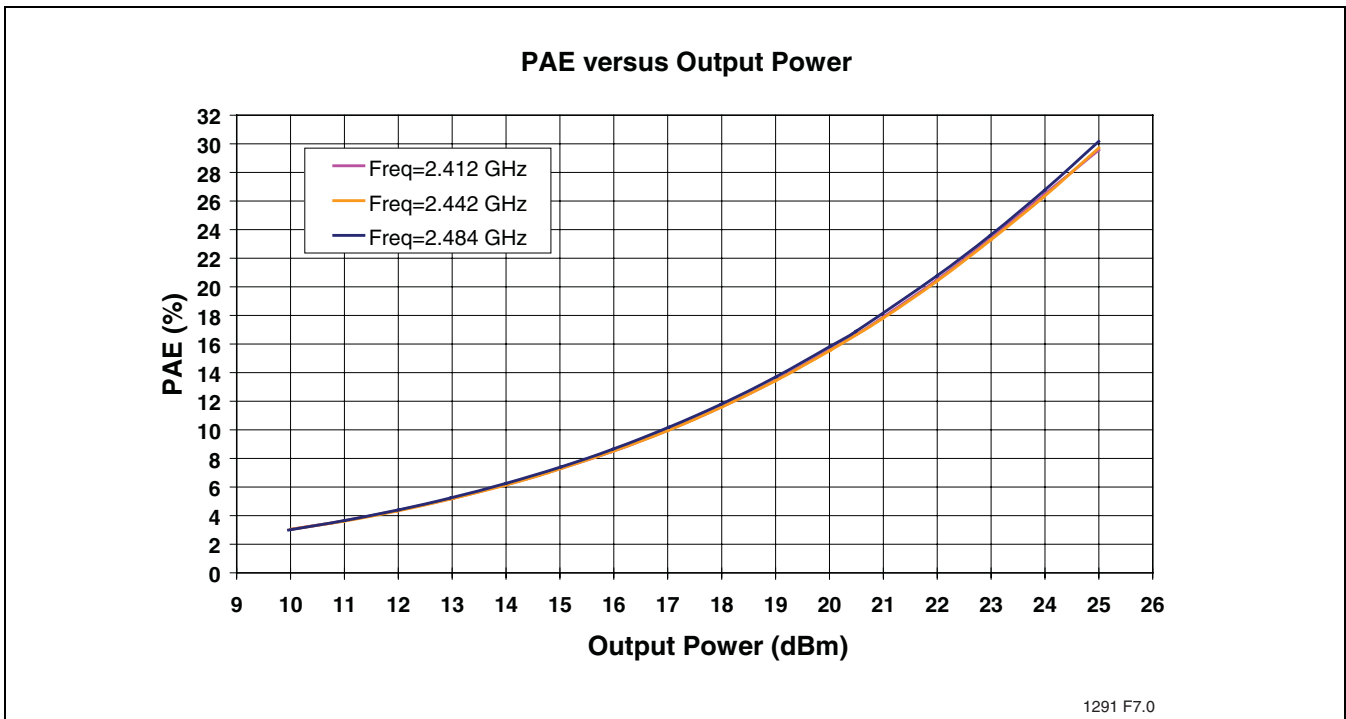

FIGURE 7: PAE versus Output Power

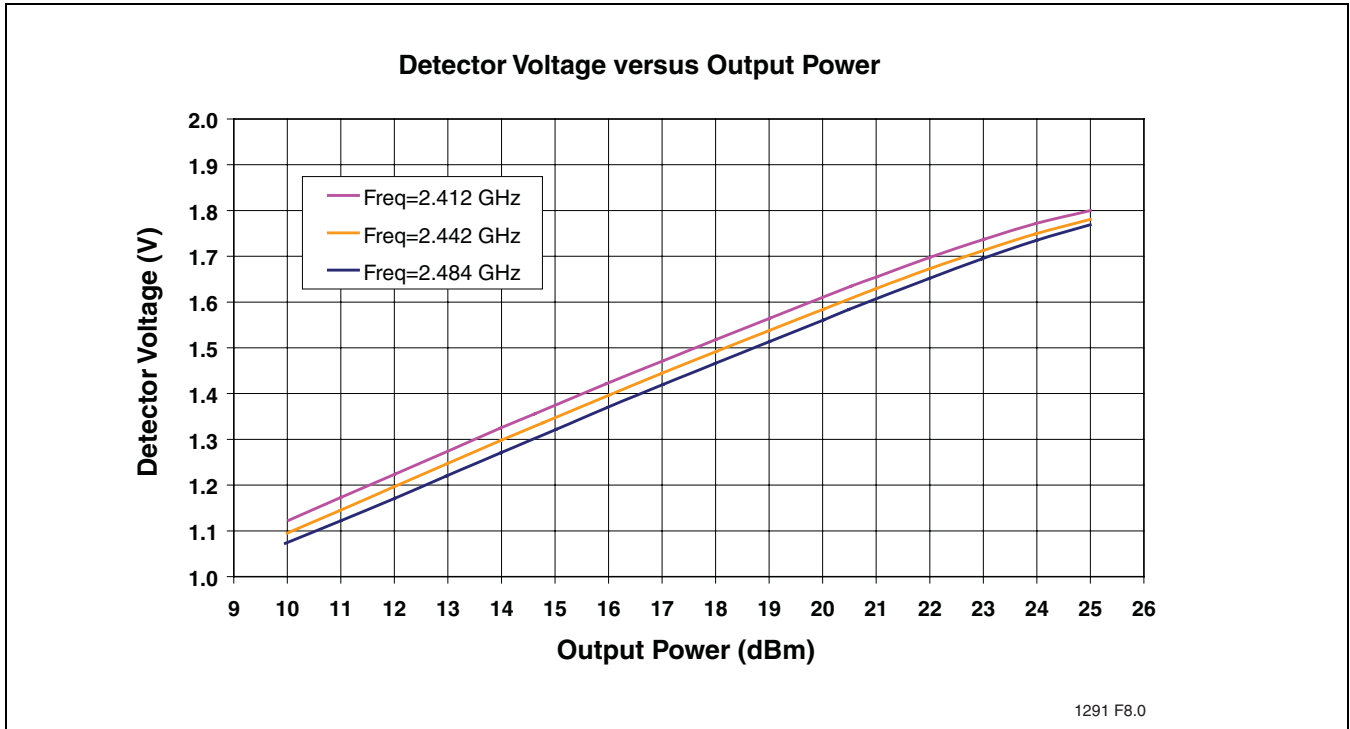

FIGURE 8: Detector Characteristic versus Output Power

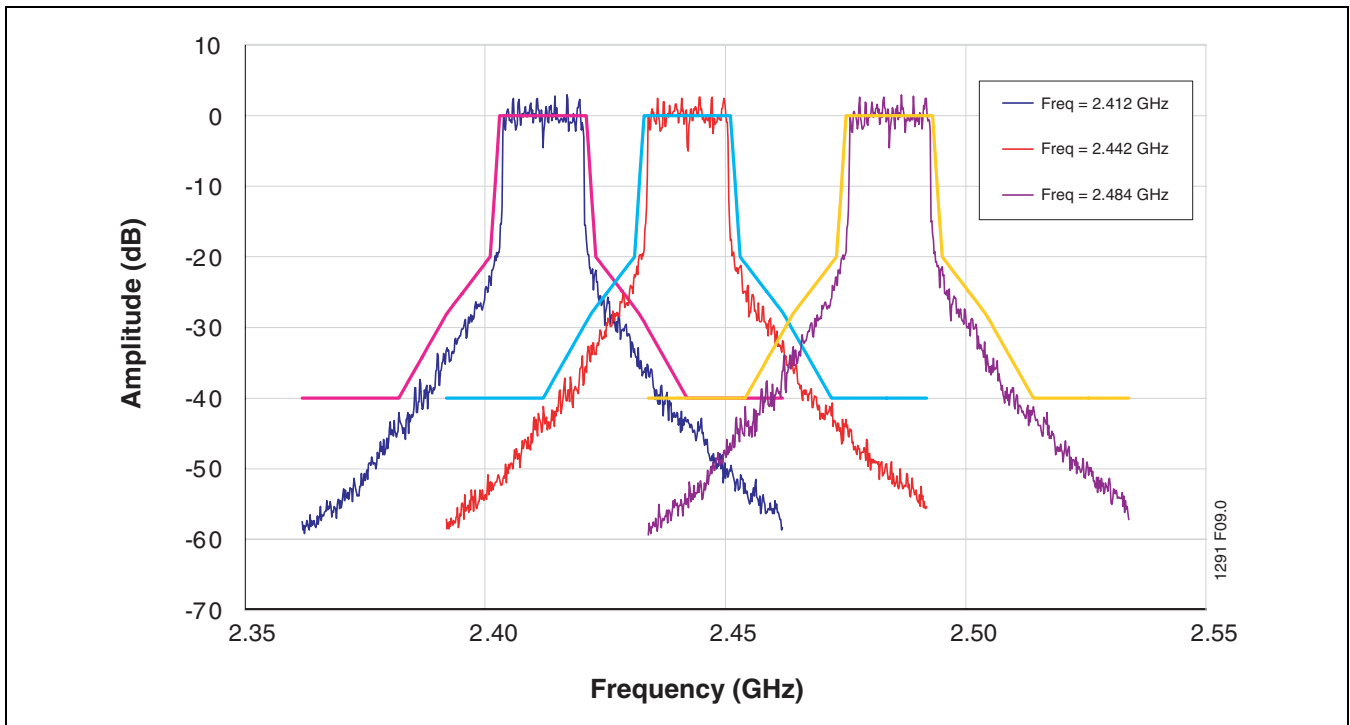

FIGURE 9: 802.11g Spectrum Mask at 24 dBm, Total current 300 mA



2.4 GHz High-Power and High-Gain Power Amplifier SST12LP15A

Data Sheet

TYPICAL PERFORMANCE CHARACTERISTICS

Test Conditions: $V_{CC} = 3.3V$, $T_A = 25^\circ C$, 1 Mbps 802.11b CCK signal

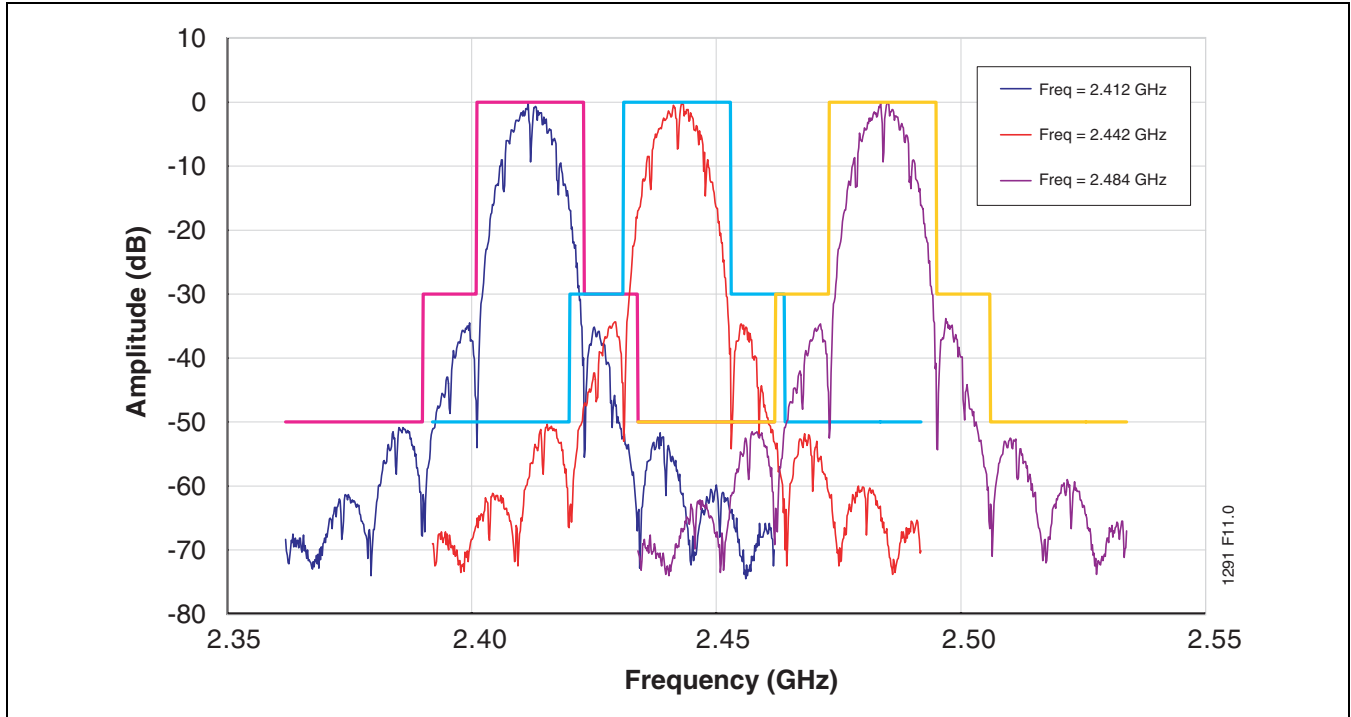

FIGURE 10: 802.11b Spectrum Mask at 25 dBm, Total current 350 mA

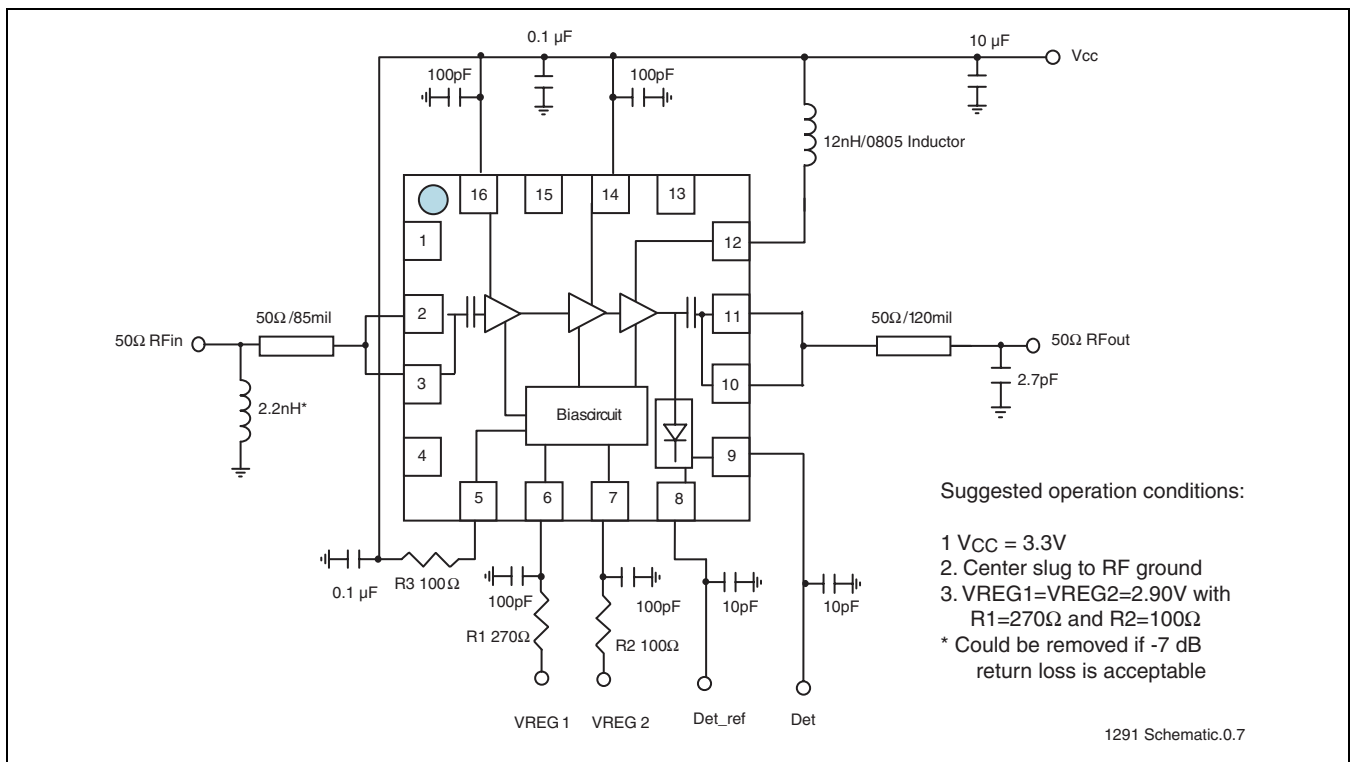

FIGURE 11: Typical Schematic for High-Power, High-Efficiency 802.11b/g Applications



2.4 GHz High-Power and High-Gain Power Amplifier SST12LP15A

Data Sheet

PRODUCT ORDERING INFORMATION

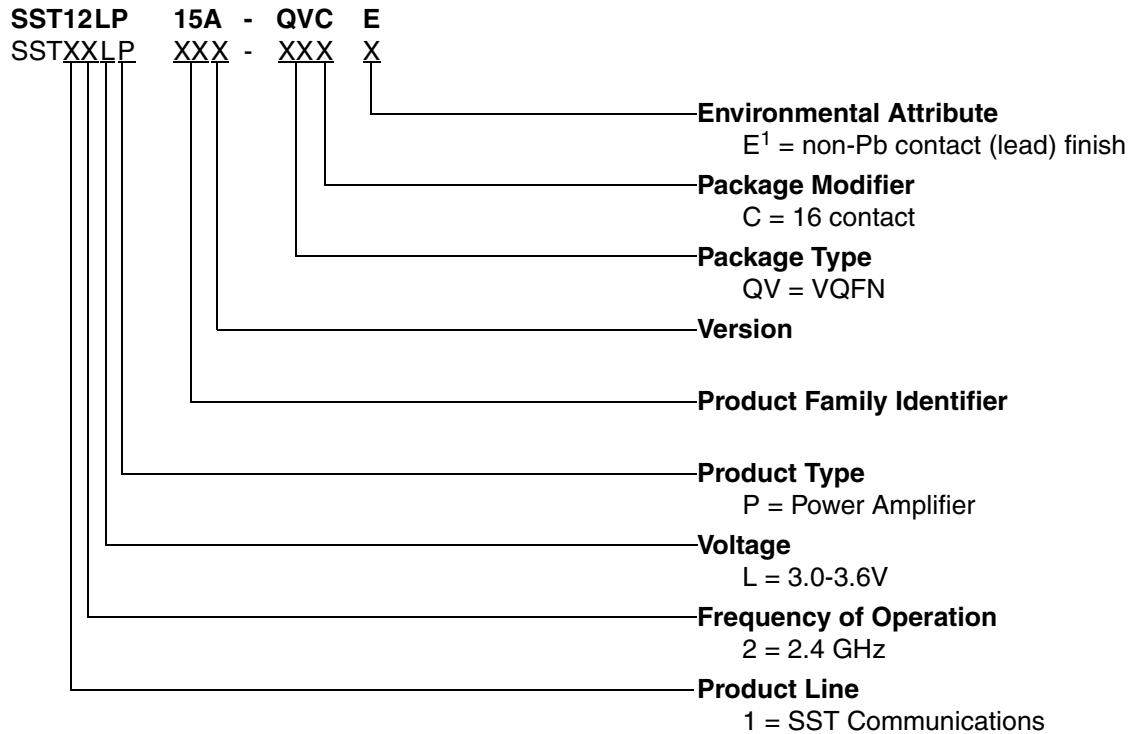

1. Environmental suffix "E" denotes non-Pb solder.
SST non-Pb solder devices are "RoHS Compliant".

Valid combinations for SST12LP15A

SST12LP15A-QVCE

SST12LP15A Evaluation Kits

SST12LP15A-QVCE-K

Note: Valid combinations are those products in mass production or will be in mass production. Consult your SST sales representative to confirm availability of valid combinations and to determine availability of new combinations.



PACKAGING DIAGRAMS

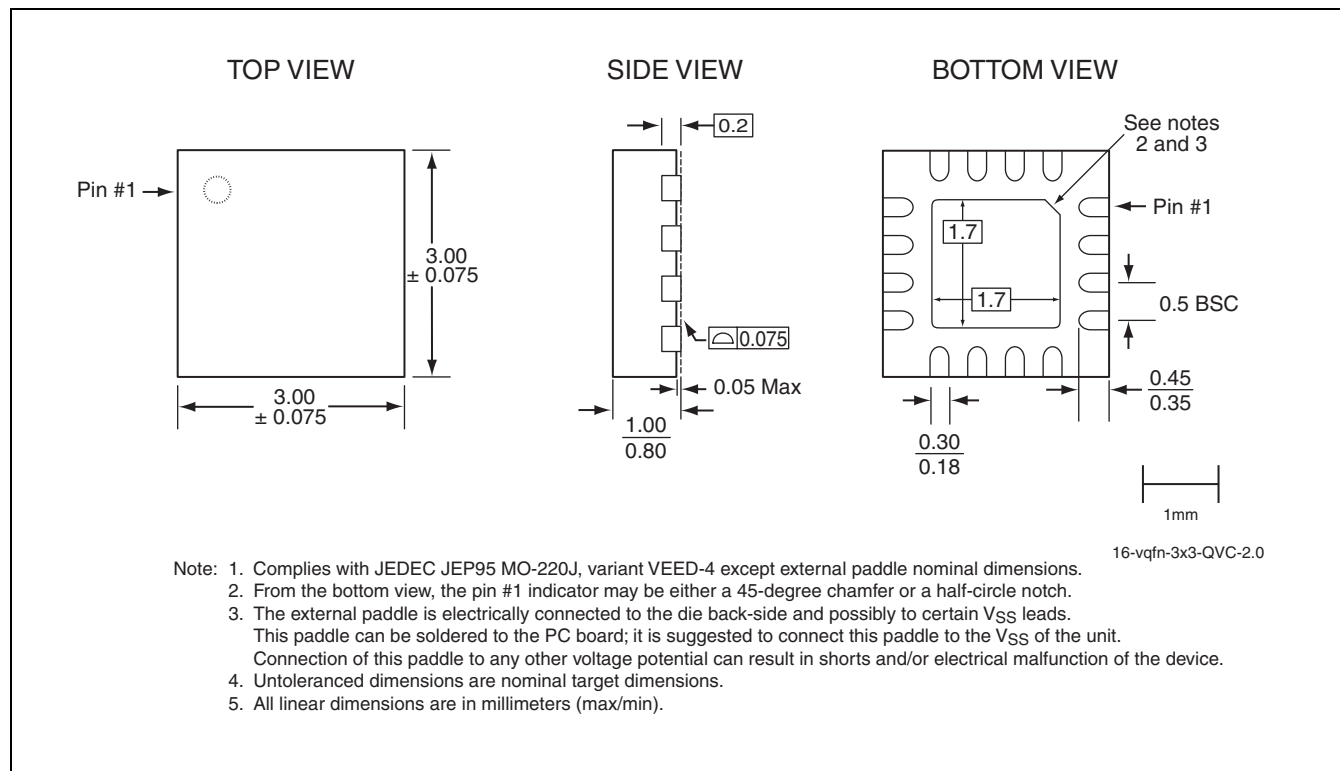

FIGURE 12: 16-contact Very-thin Quad Flat No-lead (VQFN)
SST Package Code: QVC

TABLE 4: Revision History

Revision	Description	Date
00	• Initial release of data sheet	Mar 2005
01	• Updated values for gain and efficiency on page 1 • Updated values for VREG1 and VREG2 in Table 2 on page 4 • Removed stability parameter from Table 3 on page 5 • Updated the typical application schematic on page 10 • Updated QVC package drawing. • Updated “Absolute Maximum Stress Ratings” on page 4	Mar 2006
02	• Added information for 2.3-2.4 and 2.5-2.6 applications • Removed leaded part numbers	Jul 2006
03	• Updated “Features:” and “Product Description” on page 1 • Revised Table 2 on page 4 and Table 3 on page 5 • Updated values in Figure 11 on page 10. • Removed two schematics • Updated Figures 3 - 8	Sep 2008
04	• Updated “Contact Information” on page 13.	Feb 2009



2.4 GHz High-Power and High-Gain Power Amplifier SST12LP15A

Data Sheet

CONTACT INFORMATION

Marketing

SST Communications Corp.
5340 Alla Road, Ste. 210
Los Angeles, CA 90066
Tel: 310-577-3600
Fax: 310-577-3605

Sales and Marketing Offices

NORTH AMERICA

Silicon Storage Technology, Inc.
1171 Sonora Court
Sunnyvale, CA 94086-5308
Tel: 408-735-9110
Fax: 408-735-9036

ASIA PACIFIC NORTH

SST Macao
Room N, 6th Floor,
Macao Finance Center, No. 202A-246,
Rua de Pequim, Macau
Tel: 853-2870-6022
Fax: 853-2870-6023

EUROPE

Silicon Storage Technology Ltd.
Mark House
9-11 Queens Road
Hersham, Surrey
KT12 5LU UK
Tel: 44 (0) 1932-238133
Fax: 44 (0) 1932-230567

ASIA PACIFIC SOUTH

SST Communications Co.
16F-6, No. 75, Sec.1, Sintai 5th Rd
Sijhih City, Taipei County 22101
Taiwan, R.O.C.
Tel: 886-2-8698-1198
Fax: 886-2-8698-1190

JAPAN

SST Japan
NOF Tameike Bldg, 9F
1-1-14 Akasaka, Minato-ku
Tokyo, Japan 107-0052
Tel: 81-3-5575-5515
Fax: 81-3-5575-5516

KOREA

SST Korea
6F, Heungkuk Life Insurance Bldg 6-7
Sunae-Dong, Bundang-Gu, Sungnam-Si
Kyungki-Do, Korea, 463-020
Tel: 82-31-715-9138
Fax: 82-31-715-9137

Silicon Storage Technology, Inc. • 1171 Sonora Court • Sunnyvale, CA 94086 • Telephone 408-735-9110 • Fax 408-735-9036
www.SuperFlash.com or www.sst.com

Компания «Океан Электроники» предлагает заключение долгосрочных отношений при поставках импортных электронных компонентов на взаимовыгодных условиях!

Наши преимущества:

- Поставка оригинальных импортных электронных компонентов напрямую с производств Америки, Европы и Азии, а так же с крупнейших складов мира;
- Широкая линейка поставок активных и пассивных импортных электронных компонентов (более 30 млн. наименований);
- Поставка сложных, дефицитных, либо снятых с производства позиций;
- Оперативные сроки поставки под заказ (от 5 рабочих дней);
- Экспресс доставка в любую точку России;
- Помощь Конструкторского Отдела и консультации квалифицированных инженеров;
- Техническая поддержка проекта, помощь в подборе аналогов, поставка прототипов;
- Поставка электронных компонентов под контролем ВП;
- Система менеджмента качества сертифицирована по Международному стандарту ISO 9001;
- При необходимости вся продукция военного и аэрокосмического назначения проходит испытания и сертификацию в лаборатории (по согласованию с заказчиком);
- Поставка специализированных компонентов военного и аэрокосмического уровня качества (Xilinx, Altera, Analog Devices, Intersil, Interpoint, Microsemi, Actel, Aeroflex, Peregrine, VPT, Syfer, Eurofarad, Texas Instruments, MS Kennedy, Miteq, Cobham, E2V, MA-COM, Hittite, Mini-Circuits, General Dynamics и др.);

Компания «Океан Электроники» является официальным дистрибьютором и эксклюзивным представителем в России одного из крупнейших производителей разъемов военного и аэрокосмического назначения «JONHON», а так же официальным дистрибьютором и эксклюзивным представителем в России производителя высокотехнологичных и надежных решений для передачи СВЧ сигналов «FORSTAR».



JONHON

«JONHON» (основан в 1970 г.)

Разъемы специального, военного и аэрокосмического назначения:

(Применяются в военной, авиационной, аэрокосмической, морской, железнодорожной, горно- и нефтедобывающей отраслях промышленности)

«FORSTAR» (основан в 1998 г.)

ВЧ соединители, коаксиальные кабели, кабельные сборки и микроволновые компоненты:

(Применяются в телекоммуникациях гражданского и специального назначения, в средствах связи, РЛС, а так же военной, авиационной и аэрокосмической отраслях промышленности).



Телефон: 8 (812) 309-75-97 (многоканальный)

Факс: 8 (812) 320-03-32

Электронная почта: ocean@oceanchips.ru

Web: <http://oceanchips.ru/>

Адрес: 198099, г. Санкт-Петербург, ул. Калинина, д. 2, корп. 4, лит. А