

SECTION 2

COMBINATION D-SUB CONNECTORS

Combination D-SUB Connectors provide the ideal solution for applications to require power, signal and coaxial connections within one connector. This series of connectors achieves space saving on PCB's and I/O designs.

Within this product family are various pin out configurations possible. Almost endless selections can be created mixing power, signal and coaxial contacts.

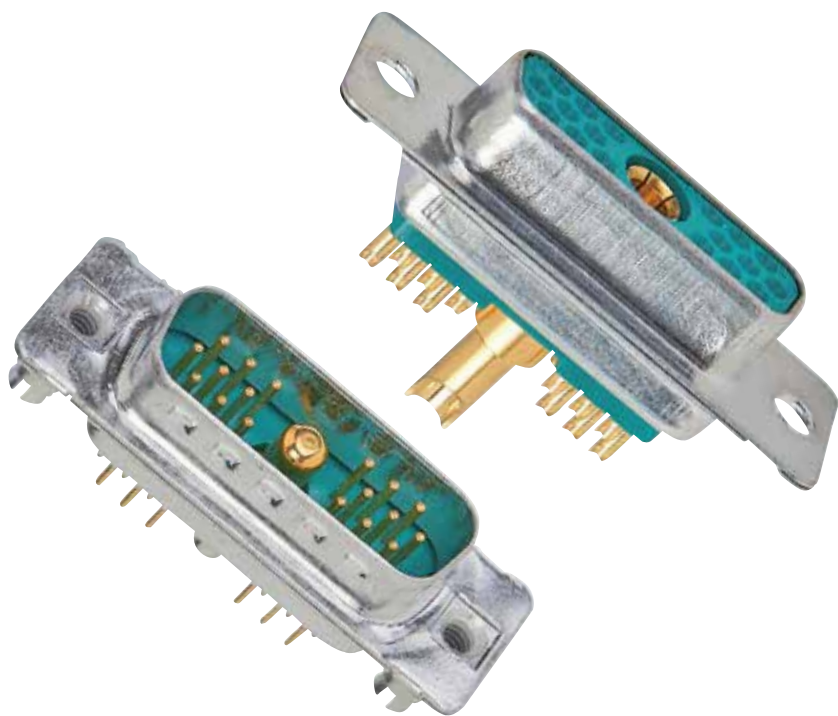

Examples are coaxial contacts handling frequencies up to 2 GHz. Power contacts from 10 amp to 40 amp current handling. Signal contacts in various styles complete the product offering.



Industry standard terminations types, solder cup, PCB contacts in straight and angled pin configurations. Crimp types and wire wrap contacts.

Here are just a few Product characteristics:

- Space savings on the PCB
- Different wire terminations are possible in a single connector
- Cost savings - mixed layout
- Insertable and removable coaxial, power, high voltage and signal contacts
- Precision machined contacts
- Various quality classes are available
- Wide product range

A wide range of standard pin configurations fully loaded with signal contacts are available. Specially configured contacts with power, coaxial and signal contacts can be constructed. Please use the Part Number Creator on page 2 | 2 and 2 | 3 or contact technical support at your closest CONEC office.



PART NUMBER CREATOR

for standard version

3 003W3 S X X 6 1 A 1 0 X

Product Line

- 3 = Shell steel tin plated
- 1 = Brass tin plated*
- 5 = Shell yellow chromated* (not RoHS compliant)
- A = Stainless steel* *on request

Shell size and design

- 1 = 5W1, 2W2C
- 2 = 3W3, 7W2, 11W1, 3W3C
- 3 = 5W5, 9W4, 13W3, 17W2, 21W1
- 4 = 8W8, 13W6, 17W5, 21WA4, 25W3, 27W2
- 5 = 24W7, 36W4, 43W2, 47W1 Empty positions ADD „0“ = 003W3

Contact type

- P = Plug connector
- S = Socket connector

Surface/Quality class for SIGNAL contacts

- A = Quality class 3 = 50 mating cycles
- B = Quality class 2 = 200 mating cycles*
- C = Quality class 1 = 500 mating cycles
- J = Special application = > 500 mating cycles (on request)*
- X = Crimp and 3W3, 5W5, 8W8, 2W2C, 3W3C (no contacts are supplied with the connector) *on request

Termination only for SIGNAL contacts

- K = Crimp without contacts
- M = Solder cup
- N = Wire wrap, .500" / 12.7 mm
- P = Press fit
- R = Solder pin, straight, .220" / 5.6 mm
- T = Solder pin, angled, .280" / 7.19 mm
- U = Solder pin, angled, .370" / 9.40 mm
- W* = Solder pin, angled, .450" / 11.43 mm
- X = 3W3, 5W5, 8W8, 2W2C, 3W3C
- Z* = Solder pin, angled, .540" / 13.84 mm
- * = please contact us

Termination for HIGH POWER- or COAXIAL contacts

- | | | |
|---------------------------------------------------------------------------------------------------------------------------------------------------------------------------------------------------------------------------------------------------------------------------------------------------------------------------------------------------------------------------------------------------------------------------------------------------------------------------------------------------------------------------------------------------------------------------------------------------------------------------------------------------------------------------------------------------------------------------------------------------------------|---------------------------------------------------------------------------------------------------------------------------------------------------------------------------------------------------------------------------------------------------------------------------------------------------------------------------------------------------------------------------------------------------------------------------------------------------------------------------------------------------------------------------------------------------------------------------------------------------------------------------------------------------------------------------------------|------------------------------------------------------------------------------------------------------------------------------------------------------------------------------------------------------------------------------------------------------------------------------------------------------------------------------------------------------------------------------------------------------------------------------------------------------------------------------------------------|
| <p>Quality class 3 / Quality class 1</p> <ul style="list-style-type: none"> C1 = Solder/Crimp angled 10 A C2 = Solder/Crimp angled 20 A C3 = Solder/Crimp angled 30 A C4 = Solder/Crimp angled 40 A F2,61 / F1,41 = Solder cup 10 A F4,62 / F3,42 = Solder cup 20 A F6,63 / F5,43 = Solder cup 30 A F8,64 / F7,44 = Solder cup 40 A 68 / 48 = Solder pin, straight 20 A, D= .077" / 1.95 mm 69 / 49 = Solder pin, straight 20 A, D= .102" / 2.60 mm 70 / 50 = Solder pin, straight 20 A, D= .110" / 2.85 mm 71 / 51 = Solder pin, straight 30 A, D= .130" / 3.18 mm 72 / 52 = Solder pin, straight 40 A, D= .150" / 3.75 mm | <p>Quality class 3 / Quality class 1</p> <ul style="list-style-type: none"> 59 / 55 = Solder pin, angled 15 A 73 / 56 = Solder pin, angled 20 A 74 / 57 = Solder pin, angled 30 A 75 / 58 = Solder pin, angled 40 A 77 / 60 = Solder pin, angled 40 A 81 / 66 = Solder pin, angled 20 A 82 / 67 = Solder pin, angled 30 A 85 / 65 = Solder pin, angled 30 A G7 / 76 = 3 Solder pins Straight 50 Ω G9 / 78 = 3 Solder pins angled 50 Ω H1 / 79 = 3 Solder pins angled 50 Ω H4 / 80 = 5 Solder pins angled 50 Ω G8 / 86 = 3 Solder pins Straight 75 Ω | <p>Quality class 3 / Quality class 1</p> <ul style="list-style-type: none"> H2 / 88 = 3 Solder pins angled 75 Ω H3 / 89 = 3 Solder pins angled 75 Ω H5 / 90 = 5 Solder pins angled 75 Ω 91 = Screw termination 20 A /P1 = press fit 30A /P2 = press fit 30A /P4 = press fit 30A 99 = no high power, coax or crimp contacts loaded
Coaxial contacts with cable termination must be ordered separately. |
|---------------------------------------------------------------------------------------------------------------------------------------------------------------------------------------------------------------------------------------------------------------------------------------------------------------------------------------------------------------------------------------------------------------------------------------------------------------------------------------------------------------------------------------------------------------------------------------------------------------------------------------------------------------------------------------------------------------------------------------------------------------|---------------------------------------------------------------------------------------------------------------------------------------------------------------------------------------------------------------------------------------------------------------------------------------------------------------------------------------------------------------------------------------------------------------------------------------------------------------------------------------------------------------------------------------------------------------------------------------------------------------------------------------------------------------------------------------|------------------------------------------------------------------------------------------------------------------------------------------------------------------------------------------------------------------------------------------------------------------------------------------------------------------------------------------------------------------------------------------------------------------------------------------------------------------------------------------------|

Mounting style

- | | |
|---------------------------------------------------------------------------------------------------------------------------------------------------------------------------------------------------------------------------------------------------------------------------------------------------------------------------------------------------------------------------------------------------------------------------------------------------------------------------------------------------------------------------------------------------------------------------------------------------------------------------------------------------------------------------------------------------------------------------------------------------------------------------------------------------------------------------------------------------------------------------------------------------------------------------------------------------------------------------------------------------------------------------------------------------------------------------------------------------------------------------------------------------------------------------------------------------------------------------------------------------------------------------------------------------------------------------------------------------------------------------------------------------------------------------------------------------------------------------------------------------------------------------------------------------------------------------------------------------------------------------------------------------------------------------------------------------------------------------------------------------------------------|---------------------------------------------------------------------------------------------------------------------------------------------------------------------------------------------------------------------------------------------------------------------------------------------------------------------------------------------------------------------------------------------------------------------------------------------------------------------------------------------------------------------------------------------------------------------------------------------------------------------------------------------------------------------------------------------------------------------------------------------------------------------------------------------------------------------------------------------------------------------------------------------------------------------------------------------------------------------------------------------------------------------------------------------------------------------------------------------------------------------------------------------------------------------------------------------------------------------------------------------------------------------------------------------------------------------------------------------------------------------------------------------------------------------------------------------------------------------------------------------------------------------------------------------------------------------------------------------------------------------------------------------------------------------------------------------------------------------------------------------------------------------------------------------------------------------------------------------------------------------------------------------------------------------------------------------------------------------------------------------------------------------|
| <ul style="list-style-type: none"> A1 = Riveted A2 = M3 threaded insert A3 = 4-40 UNC threaded insert A4 = M3 threaded rear spacer A5 = 4-40 UNC threaded rear spacer A6 = Float fastening A7 = Threaded rear spacer for M3 press fit A8 = Threaded rear spacer for 4-40 UNC press fit C1 = M3 threaded rear spacer with PCB clip, PCB .063" / 1.60 mm C2 = 4-40 UNC threaded rear spacer with PCB clip, PCB .063" / 1.60 mm C3 = M3 threaded rear spacer with PCB clip, PCB .091" / 2.30 mm C4 = 4-40 UNC threaded rear spacer with PCB clip, PCB .091" / 2.30 mm C5 = M3 threaded rear spacer with PCB clip, PCB .126" / 3.20 mm C6 = 4-40 UNC Threaded rear spacer with PCB clip, PCB .126" / 3.20 mm D1 = M3 clip and threaded rear spacer with PCB clip, PCB .063" / 1.60 mm D2 = 4-40 UNC clip and threaded rear spacer with PCB clip, PCB .063" / 1.60 mm D3 = M3 clip and threaded rear spacer with PCB clip, PCB .091" / 2.30 mm D4 = 4-40 UNC clip and threaded rear spacer with PCB clip, PCB .091" / 2.30 mm D5 = M3 clip and threaded rear spacer with PCB clip, PCB .126" / 3.20 mm D6 = 4-40 UNC clip and threaded rear spacer with PCB clip, PCB .126" / 3.20 mm E1 = M3 threaded rear spacer with PCB clip, PCB .063" / 1.60 mm E2 = 4-40 UNC threaded rear spacer with PCB clip, PCB .063" / 1.60 mm E3 = M3 threaded rear spacer with PCB clip, PCB .091" / 2.30 mm E4 = 4-40 UNC threaded rear spacer with PCB clip, PCB .091" / 2.30 mm E5 = M3 threaded rear spacer with PCB clip, PCB .126" / 3.20 mm | <ul style="list-style-type: none"> E6 = 4-40 UNC threaded rear spacer with PCB clip, PCB .126" / 3.20 mm F1 = M3 clip and threaded rear spacer with PCB clip, PCB .063" / 1.60 mm F2 = 4-40 UNC clip and threaded rear spacer with PCB clip, PCB .063" / 1.60 mm F3 = M3 clip and threaded rear spacer with PCB clip, PCB .091" / 2.30 mm F4 = 4-40 UNC clip and threaded rear spacer with PCB clip, PCB .091" / 2.30 mm F5 = M3 clip and threaded rear spacer with PCB clip, PCB .126" / 3.20 mm F6 = 4-40 UNC clip and threaded rear spacer with PCB clip, PCB .126" / 3.20 mm G1 = Metal bracket, M3 threaded insert for .370" / 9.40 mm G2 = Metal bracket, 4-40 UNC threaded insert for .370" / 9.40 mm G3 = Metal bracket, M3 threaded insert and clip for .370" / 9.40 mm G4 = Metal bracket, 4-40 UNC threaded insert and clip for .370" / 9.40 mm H1 = Metal bracket, M3 threaded lock for .370" / 9.40 mm H2 = Metal bracket, 4-40 UNC threaded lock for .370" / 9.40 mm H3 = Metal bracket, M3 threaded lock and clip for .370" / 9.40 mm H4 = Metal bracket, 4-40 UNC threaded lock and clip for .370" / 9.40 mm N1 = Metal bracket, M3 threaded insert for .280" / 7.19 mm N2 = Metal bracket, 4-40 UNC threaded insert for .280" / 7.19 mm N3 = Metal bracket, M3 threaded insert and clip for .280" / 7.19 mm N4 = Metal bracket, 4-40 UNC threaded insert and clip for .280" / 7.19 mm P1 = Metal bracket, M3 threaded lock for .280" / 7.19 mm P2 = Metal bracket, 4-40 UNC threaded lock for .280" / 7.19 mm P3 = Metal bracket, M3 threaded lock and clip for .280" / 7.19 mm P4 = Metal bracket, 4-40 UNC threaded lock and clip for .280" / 7.19 mm W1 = Threaded rear spacer with M3 press in pin W2 = Threaded rear spacer with 4-40 UNC press in pin |
|---------------------------------------------------------------------------------------------------------------------------------------------------------------------------------------------------------------------------------------------------------------------------------------------------------------------------------------------------------------------------------------------------------------------------------------------------------------------------------------------------------------------------------------------------------------------------------------------------------------------------------------------------------------------------------------------------------------------------------------------------------------------------------------------------------------------------------------------------------------------------------------------------------------------------------------------------------------------------------------------------------------------------------------------------------------------------------------------------------------------------------------------------------------------------------------------------------------------------------------------------------------------------------------------------------------------------------------------------------------------------------------------------------------------------------------------------------------------------------------------------------------------------------------------------------------------------------------------------------------------------------------------------------------------------------------------------------------------------------------------------------------------|---------------------------------------------------------------------------------------------------------------------------------------------------------------------------------------------------------------------------------------------------------------------------------------------------------------------------------------------------------------------------------------------------------------------------------------------------------------------------------------------------------------------------------------------------------------------------------------------------------------------------------------------------------------------------------------------------------------------------------------------------------------------------------------------------------------------------------------------------------------------------------------------------------------------------------------------------------------------------------------------------------------------------------------------------------------------------------------------------------------------------------------------------------------------------------------------------------------------------------------------------------------------------------------------------------------------------------------------------------------------------------------------------------------------------------------------------------------------------------------------------------------------------------------------------------------------------------------------------------------------------------------------------------------------------------------------------------------------------------------------------------------------------------------------------------------------------------------------------------------------------------------------------------------------------------------------------------------------------------------------------------------------|

OX = Standard

TECHNICAL DATA

Standard version

Materials	Connector with signal contacts	Coaxial contacts	High power contacts	High voltage contacts
Insulator Green standard / black crimp	PBTP, GV (UL94 V-0)			
Shell	steel tin plated brass tin / stainless steel on request			
Contact plating	Gold plated over nickel			
Contact material	CU alloy			
Retaining clip	CU alloy			
Insulator		PTFE/PBTP/PI		PTFE
Mechanical and electrical characteristics				
Current rating	7,5A (UL) / 5A (CSA, VDE)			
Test voltage between 2 contacts contact and shell	1000 V, 50Hz 1 min.		1000 V, 50Hz 1 min.	
Resistance between mated contacts	max. 8 mΩ	max. 2.7 mΩ	max. 1 mΩ	max. 2.7 mΩ
Insulation resistance	≥5 GΩ	≥ 10 GΩ	≥ 5 GΩ	≥ 2x10 ⁷ MΩ
Volume resistivity	10 ¹⁶ Ωcm			
Dielectric impedance	50KV/mm			
Characteristic impedance		50/75 Ω		
VSWR-value at according MIL-C-39012	1.2GHz 1.5GHz 2.0GHz		≤1,2 ≤1,3 ≤1,5	
Dielectric voltage		750V 50Hz		3.8kV
Frequency range		0-2GHz		
Working voltage	250 V	250 V	250 V	max. 2.8kV
Temperature range	-55°C to +125°C			
Insertion force per contact	3.4N	7N	7N	5N
Extraction force per contact	0.2N	7N	approx. 5N	approx. 2.5N
Mating cycles	A = Quality class 3 = 50 mating cycles, B = Quality class 2 = 200 mating cycles, C = Quality class 1 = 500 mating cycles			

Technical specifications are subject to change without notice.

PIN CONFIGURATION – MATING SIDE OF SOCKET CONNECTOR

SHELL SIZE 1



SHELL SIZE 2



SHELL SIZE 3



SHELL SIZE 4



SHELL SIZE 5



Connectors 3W3, 5W5 and 8W8 with female insulators: Socket contacts are fingerprobe safe according to UL 1950 and CSA 22.2.950.

TECHNICAL INFORMATION

SKIN EFFECT

Alternating currents do not uniformly occupy the entire cross section of the conductor, rather inductance effect in the conductor deflects the current towards the surface of the conductor, whereby this deflection increases with the frequency.

The resistive attenuation of a transmission line increases with the frequency as a result of this skin effect.

The skin depth (equivalent thickness of the layer in which current flows) can be determined using

$$\delta = \frac{1}{\sqrt{f \pi \sigma \mu_0 \mu_r}}$$

f = frequency

σ = conductivity of the conductor material

$\sigma_{Ag} = 62 \times 10^6 \text{ S/m}$

$\sigma_{Cu} = 58 \times 10^6 \text{ S/m}$

$\mu_0 = 1,256 \cdot 10^{-6} \text{ Vs / Am}$

μ_r ... relative permeability constant for the employed material

VSWR-VALUE

The ratio between the value of the largest and the smallest voltages on a loss-free line is known as the ripple or voltage standing wave ratio s (where $1 \leq s < \infty$). The reciprocal value of the VSWR is known as the inverse voltage standing wave ratio m (where $0 < m \leq 1$).

(VSWR = Voltage standing wave ratio)

The value of s is linked with the → reflection coefficient r on s transmission line according to the equation

$$s = \frac{(1 + |r|)}{(1 - |r|)}$$

DERATING CURVE

Measurement is according to DIN 41640 part 3 whereas all power contacts are connected in series.

For test procedure – product-no. 3008W8SXX99A has been equipped with 132C11049X and 3008W8PXX99AA10X with 131C11049X.



MATING CONDITIONS

Float mount tolerance guide



Rigid mount tolerance guide



Rigid mount vertical to tolerance guide



PANEL CUT-OUT

Rear panel mounting Front panel mounting

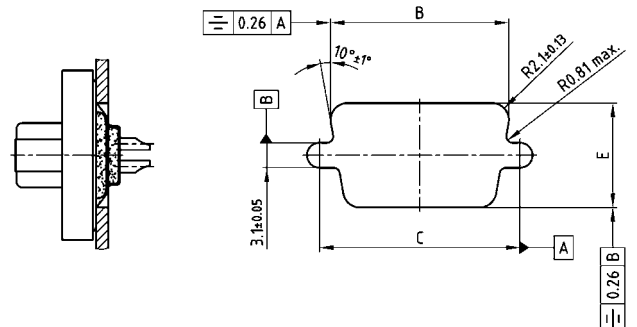
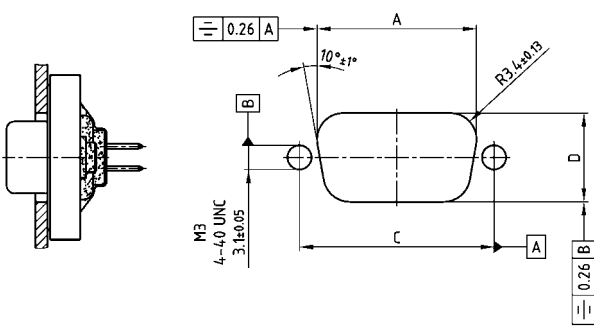

Shell size	A ± 0,13	B ± 0,13	C ± 0,13	D ± 0,13	E ± 0,13
1	20.50	22.20	25.00	11.40	13.00
2	28.80	30.50	33.30	11.40	13.00
3	42.50	44.30	47.04	11.40	13.00
4	59.10	60.70	63.50	11.40	13.00
5	56.30	58.30	61.10	14.10	15.80

CRIMPING INSTRUCTIONS FOR COAX CONTACTS



Strip the wire
Using dimensions shown on the
individual product drawings



Slide sleeve over coax cable



Crimp the inner contact on the
inner conductor



Snap the inner contact into
the outer contact



Slide braid over outer contact



Crimp the sleeve on to outer
contact

Компания «Океан Электроники» предлагает заключение долгосрочных отношений при поставках импортных электронных компонентов на взаимовыгодных условиях!

Наши преимущества:

- Поставка оригинальных импортных электронных компонентов напрямую с производств Америки, Европы и Азии, а так же с крупнейших складов мира;
- Широкая линейка поставок активных и пассивных импортных электронных компонентов (более 30 млн. наименований);
- Поставка сложных, дефицитных, либо снятых с производства позиций;
- Оперативные сроки поставки под заказ (от 5 рабочих дней);
- Экспресс доставка в любую точку России;
- Помощь Конструкторского Отдела и консультации квалифицированных инженеров;
- Техническая поддержка проекта, помощь в подборе аналогов, поставка прототипов;
- Поставка электронных компонентов под контролем ВП;
- Система менеджмента качества сертифицирована по Международному стандарту ISO 9001;
- При необходимости вся продукция военного и аэрокосмического назначения проходит испытания и сертификацию в лаборатории (по согласованию с заказчиком);
- Поставка специализированных компонентов военного и аэрокосмического уровня качества (Xilinx, Altera, Analog Devices, Intersil, Interpoint, Microsemi, Actel, Aeroflex, Peregrine, VPT, Syfer, Eurofarad, Texas Instruments, MS Kennedy, Miteq, Cobham, E2V, MA-COM, Hittite, Mini-Circuits, General Dynamics и др.);

Компания «Океан Электроники» является официальным дистрибьютором и эксклюзивным представителем в России одного из крупнейших производителей разъемов военного и аэрокосмического назначения «JONHON», а так же официальным дистрибьютором и эксклюзивным представителем в России производителя высокотехнологичных и надежных решений для передачи СВЧ сигналов «FORSTAR».



JONHON

«JONHON» (основан в 1970 г.)

Разъемы специального, военного и аэрокосмического назначения:

(Применяются в военной, авиационной, аэрокосмической, морской, железнодорожной, горно- и нефтедобывающей отраслях промышленности)

«FORSTAR» (основан в 1998 г.)

ВЧ соединители, коаксиальные кабели,
кабельные сборки и микроволновые компоненты:

(Применяются в телекоммуникациях гражданского и специального назначения, в средствах связи, РЛС, а так же военной, авиационной и аэрокосмической отраслях промышленности).



Телефон: 8 (812) 309-75-97 (многоканальный)

Факс: 8 (812) 320-03-32

Электронная почта: ocean@oceanchips.ru

Web: <http://oceanchips.ru/>

Адрес: 198099, г. Санкт-Петербург, ул. Калинина, д. 2, корп. 4, лит. А