

- High-Resolution Conversion of Light Intensity to Frequency With No External Components
- High Irradiance Responsivity . . . 2.3 kHz/($\mu\text{W}/\text{cm}^2$) at $\lambda_p = 524 \text{ nm}$
- Low Dark Frequency . . . < 2 Hz at 50° C
- Single-Supply Operation . . . 2.7 V to 5.5 V
- Stable 200 ppm/°C Temperature Coefficient
- Interfaces Directly to a Microcontroller
- RoHS Compliant (–LF Package Only)

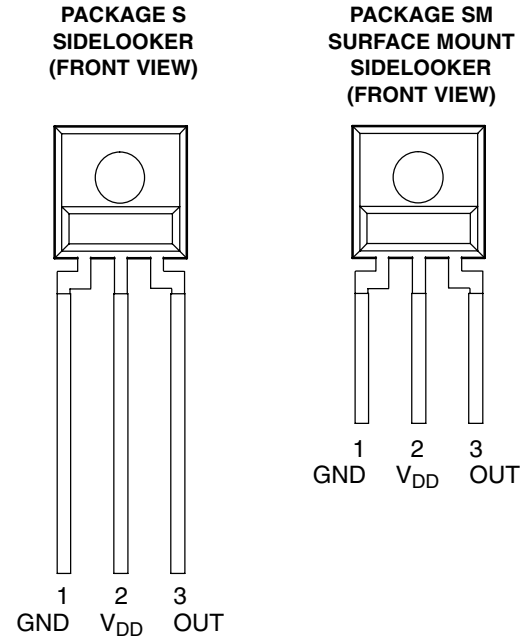

Description

The TSL237 light-to-frequency converter combines a silicon photodiode and a current-to-frequency converter on a single monolithic CMOS integrated circuit. Output is a square wave (50% duty cycle) with frequency directly proportional to light intensity (irradiance) on the photodiode. The digital output allows direct interface to a microcontroller or other logic circuitry. The device has been temperature compensated for the ultraviolet-to-visible light range of 320 nm to 700 nm and responds over the light range of 320 nm to 1050 nm. The TSL237 is characterized for operation over the temperature range of –40°C to 85°C and is supplied in a 3-lead clear plastic side-looker package with an integral lens. When supplied in the lead (Pb) free package, the device is RoHS compliant.

For automotive and other extended temperature applications, please contact TAOS for information.

Functional Block Diagram



Available Options

DEVICE	T _A	PACKAGE – LEADS	PACKAGE DESIGNATOR	ORDERING NUMBER
TSL237	–40°C to 70°C	3-lead Sidelooker	S	TSL237S
TSL237	–40°C to 70°C	3-lead Sidelooker — Lead (Pb) Free	S	TSL237S–LF
TSL237	–40°C to 70°C	3-lead Surface-Mount Sidelooker — Lead (Pb) Free	SM	TSL237SM–LF

TSL237 HIGH-SENSITIVITY LIGHT-TO-FREQUENCY CONVERTER

TAOS052J – SEPTEMBER 2008

Terminal Functions

TERMINAL NAME	NO.	TYPE	DESCRIPTION
GND	1		Power supply ground (substrate). All voltages are referenced to GND.
OUT	3	O	Output frequency.
V _{DD}	2		Supply voltage.

Absolute Maximum Ratings over operating free-air temperature range (unless otherwise noted)†

Supply voltage, V _{DD} (see Note 1)	6 V
Operating free-air temperature range, T _A (see Note 2)	–40°C to 85°C
Storage temperature range, T _{stg} (see Note 2)	–40°C to 85°C
Lead temperature 1,6 mm (1/16 inch) from case for 10 seconds (S Package)	260°C
Reflow solder, in accordance with J-STD-020C or J-STD-020D (SM Package)	260°C

† Stresses beyond those listed under “absolute maximum ratings” may cause permanent damage to the device. These are stress ratings only, and functional operation of the device at these or any other conditions beyond those indicated under “recommended operating conditions” is not implied. Exposure to absolute-maximum-rated conditions for extended periods may affect device reliability.

NOTES: 1. All voltage values are with respect to GND.

2. Long-term storage or operation above 70°C could cause package yellowing that will lower the sensitivity to wavelengths < 500nm.

Recommended Operating Conditions

	MIN	NOM	MAX	UNIT
Supply voltage, V _{DD}	2.7	5	5.5	V
Operating free-air temperature range, T _A	–40		70	°C

Electrical Characteristics at V_{DD} = 5 V, T_A = 25°C (unless otherwise noted)

PARAMETER	TEST CONDITIONS	MIN	TYP	MAX	UNIT
V _{OH} High-level output voltage	I _{OH} = –1 mA	4	4.5		V
V _{OL} Low-level output voltage	I _{OL} = 1 mA		0.25	0.4	V
I _{DD} Supply current			2	3	mA
Full-scale frequency‡		500		1000	kHz
Temperature coefficient of responsivity	Wavelength < 600nm, f _O = 50 kHz		±200		ppm/°C
k _{SVS} Supply-voltage sensitivity	V _{DD} = 5 V ±10%		±0.5		%/V

‡ Full-scale frequency is the maximum operating frequency of the device without saturation.

Operating Characteristics at V_{DD} = 5 V, T_A = 25°C, λ_p = 524 nm (unless otherwise noted)

PARAMETER	TEST CONDITIONS	MIN	TYP	MAX	UNIT
f _O Output frequency	E _e = 21.8 μW/cm ²	40	50	60	kHz
f _D Dark frequency	E _e = 0 μW/cm ²	0	0.1		Hz
	E _e = 0 μW/cm ² , T _A = 50°C	0		2	Hz
R _e Irradiance responsivity			2.3		kHz/(μW/cm ²)
Nonlinearity§	f _O = 0 kHz to 10 kHz		±1%		%F.S.
Step response to full-scale step input			1 pulse of new frequency plus 1 μs		

§ Nonlinearity is defined as the deviation of f_O from a straight line between zero and full scale, expressed as a percent of full scale.

TYPICAL CHARACTERISTICS

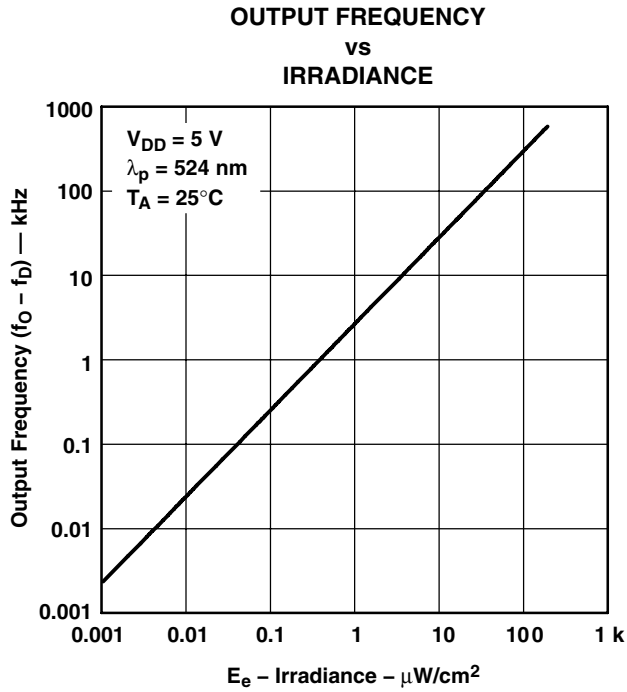

Figure 1

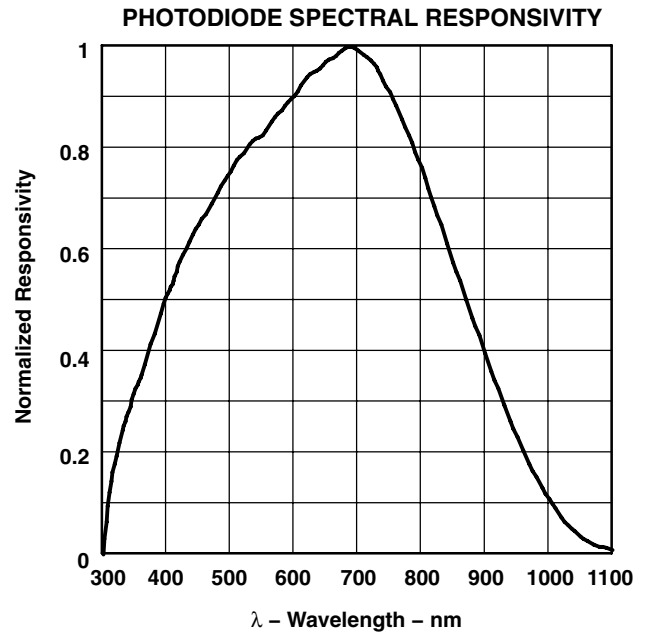

Figure 2

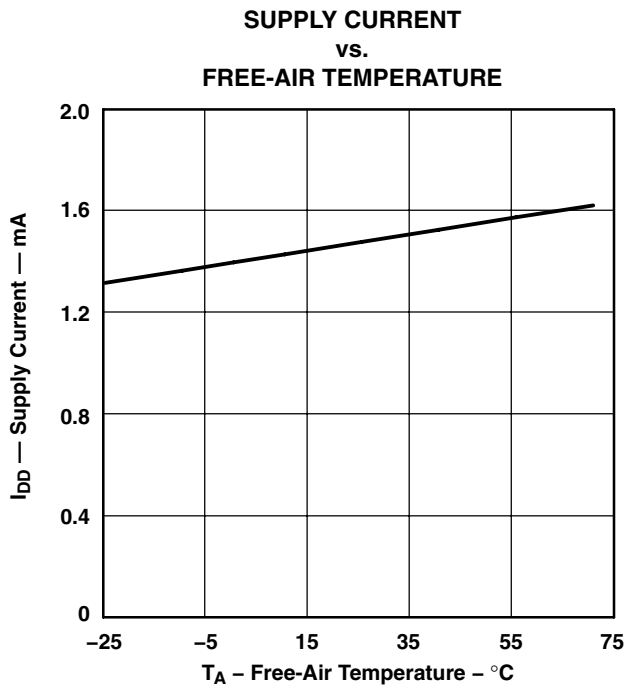

Figure 3

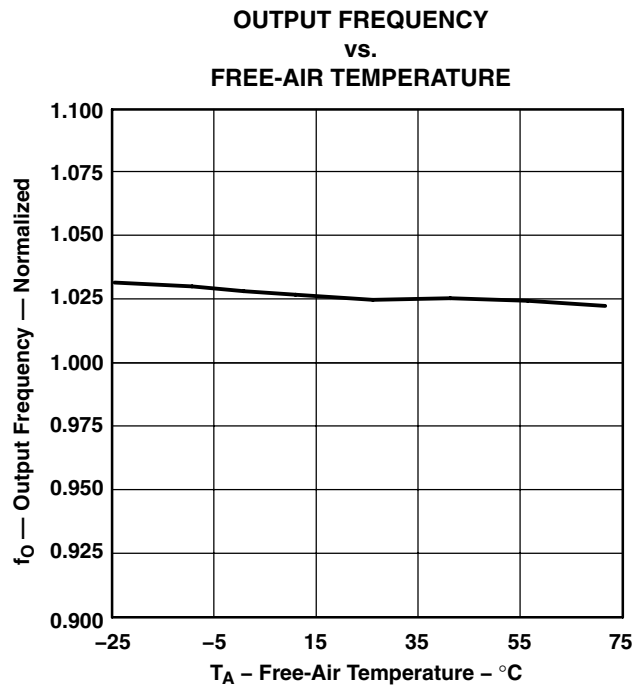

Figure 4

TYPICAL CHARACTERISTICS

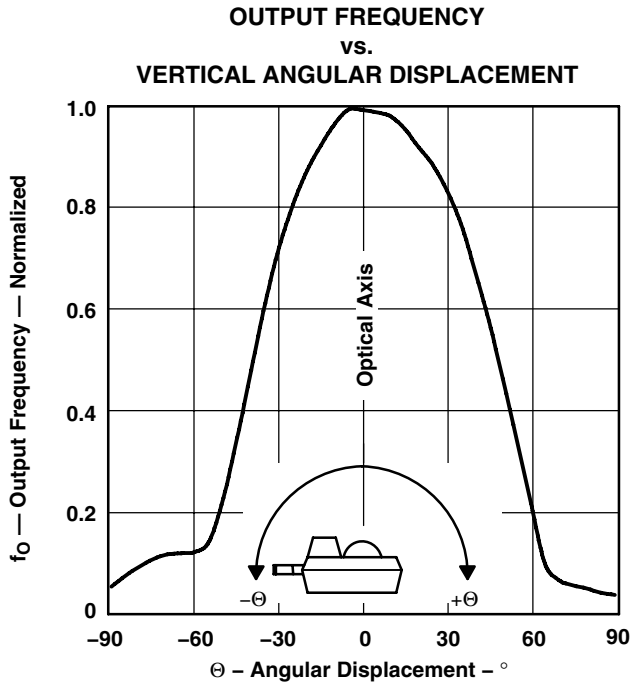

Figure 5

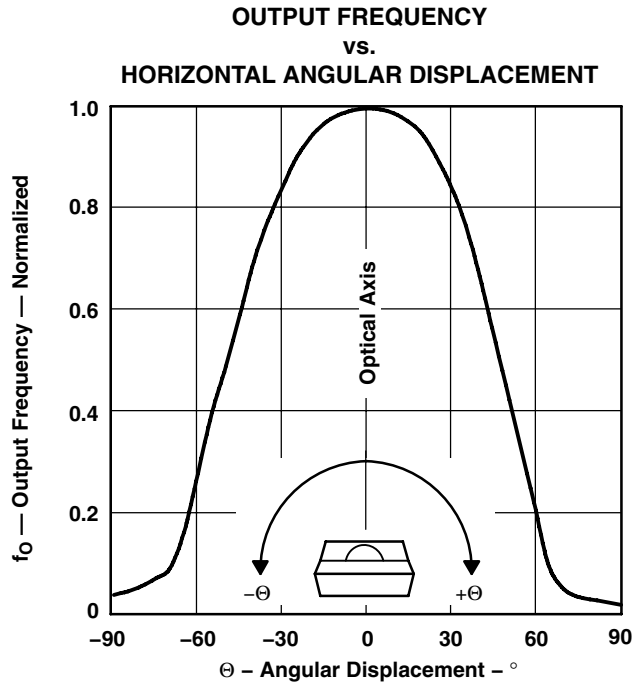

Figure 6

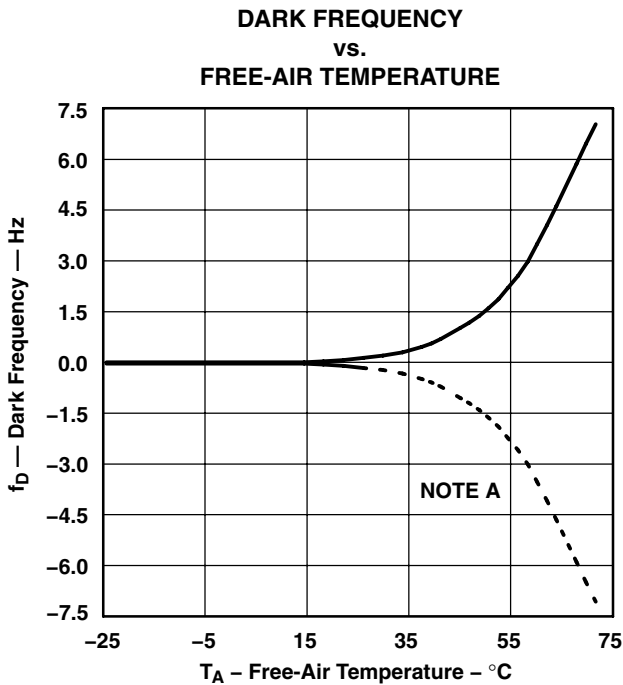

Figure 7

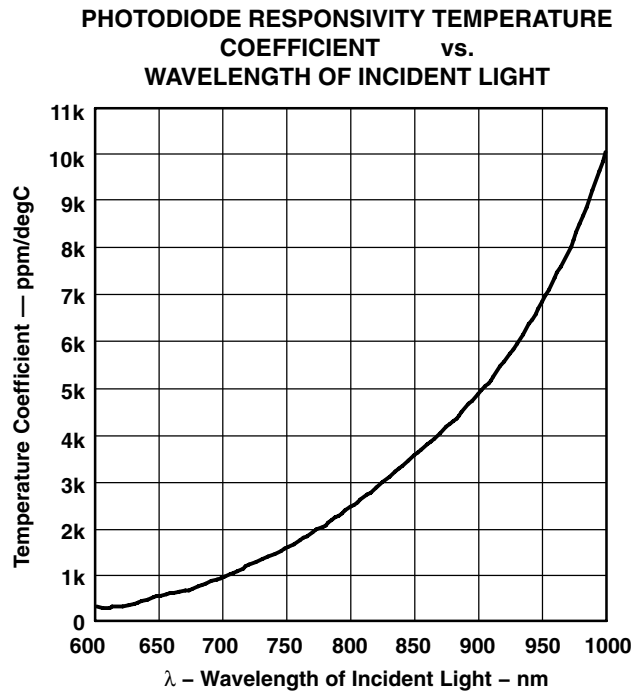

Figure 8

NOTE A: Internal offsets that result in dark frequency can be both positive and negative. The dashed line represents the case of negative offset in which an equivalent amount of light signal is required to obtain a non-zero output frequency.

APPLICATION INFORMATION

Power-Supply Considerations

Power-supply lines must be decoupled by a 0.01- μF to 0.1- μF capacitor with short leads placed close to the TSL237 (Figure 9). A low-noise power supply is required to minimize jitter on output pulse.

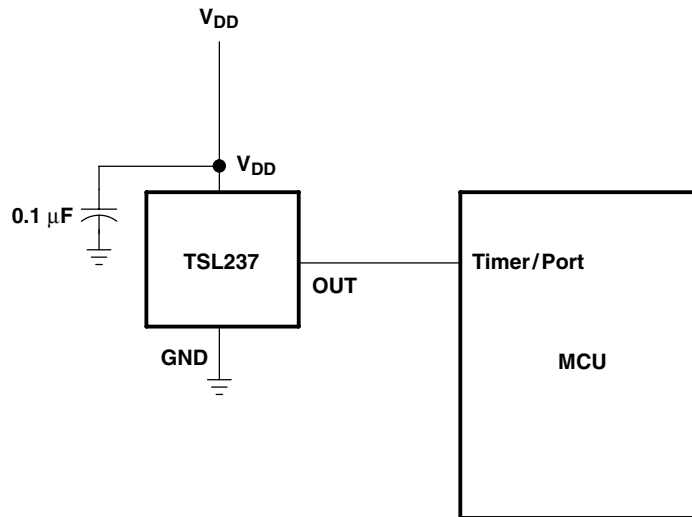

Figure 9. Typical TSL237 Interface to a Microcontroller

Device Operational Details

The frequency at the output pin (OUT) is given by:

$$f_O = f_D + (R_e)(E_e)$$

where:

- f_O is the output frequency
- f_D is the output frequency for dark condition ($E_e = 0$)
- R_e is the device responsivity for a given wavelength of light given in $\text{kHz}/(\mu\text{W}/\text{cm}^2)$
- E_e is the incident irradiance in $\mu\text{W}/\text{cm}^2$

f_D is a constant error term in the output frequency calculation resulting from leakage currents, and is independent of light intensity. The TSL237 die is trimmed to minimize the magnitude of this dark frequency component so that it can be neglected in the transfer function calculation. In many applications, measurement of the actual dark frequency may be impractical due to measurement times ranging from several seconds to several minutes, and the fact that some devices may never transition (zero dark frequency).

Output Interface

The output of the device is designed to drive a CMOS logic input over short distances. If lines greater than 12 inches in length are used on the output, a buffer or line driver is recommended.

APPLICATION INFORMATION

Measuring the Frequency

The choice of interface and measurement technique depends on the desired resolution and data-acquisition rate. For maximum data-acquisition rate, period-measurement techniques are used.

Period measurement requires the use of a fast reference clock with available resolution directly related to the reference-clock rate. The technique is employed to measure rapidly varying light levels or to make a fast measurement of a constant light source.

Maximum resolution and accuracy may be obtained using frequency-measurement, pulse-accumulation, or integration techniques. Frequency measurements provide the added benefit of averaging out random- or high-frequency variations (jitter) resulting from noise in the light signal. Resolution is limited mainly by available counter registers and allowable measurement time. Frequency measurement is well suited for slowly varying or constant light levels and for reading average light levels over short periods of time. Integration, the accumulation of pulses over a very long period of time, can be used to measure exposure — the amount of light present in an area over a given time period.

PCB Pad Layout

Suggested PCB pad layout guidelines for the SM surface mount package are shown in Figure 10.

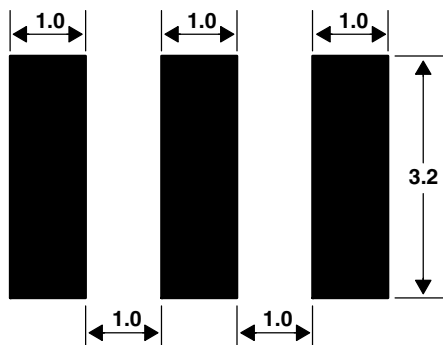

- NOTES: A. All linear dimensions are in millimeters.
B. This drawing is subject to change without notice.

Figure 10. Suggested SM Package PCB Layout

MECHANICAL DATA

The device is supplied in a clear plastic three-lead through-hole package.

PACKAGE S
TOP VIEW

PLASTIC SINGLE-IN-LINE SIDE-LOOKER PACKAGE

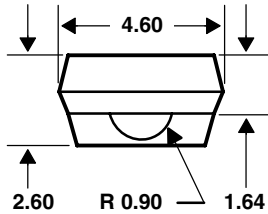

FRONT VIEW

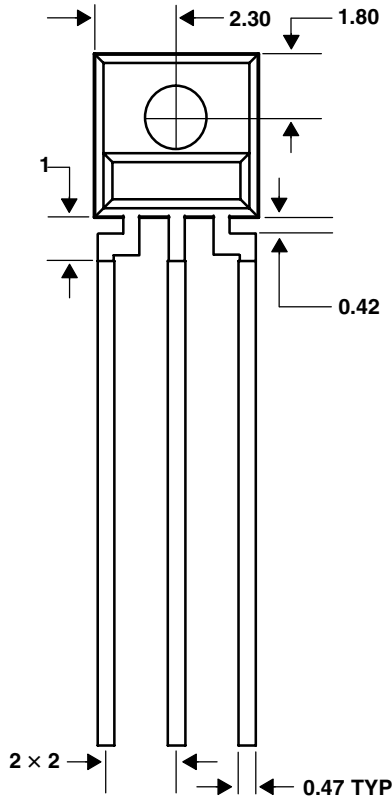

SIDE VIEW

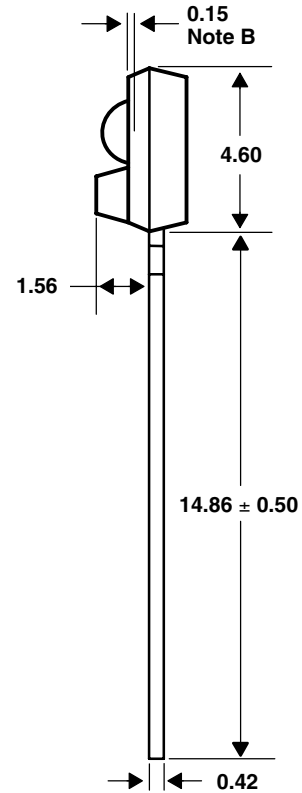

Lead Free Available

- NOTES: A. All linear dimensions are in millimeters; tolerance is ± 0.25 mm unless otherwise stated.
 B. Dimension is to center of lens arc, which is located below the package face.
 C. The integrated photodiode active area is typically 0.92 mm^2 in size and is located in the center of the lens and 0.97 mm below the top of the lens surface.
 D. Index of refraction of clear plastic is 1.55.
 E. Lead finish for TSL237: solder dipped, 63% Sn/37% Pb. Lead finish for TSL237-LF: solder dipped, 100% Sn.
 F. This drawing is subject to change without notice.

Figure 11. Package S — Single-In-Line Side-Looker Package Configuration

**TSL237
HIGH-SENSITIVITY
LIGHT-TO-FREQUENCY CONVERTER**

TAOS052J – SEPTEMBER 2008

MECHANICAL DATA

PACKAGE SM

PLASTIC SURFACE MOUNT SIDE-LOOKER PACKAGE

TOP VIEW

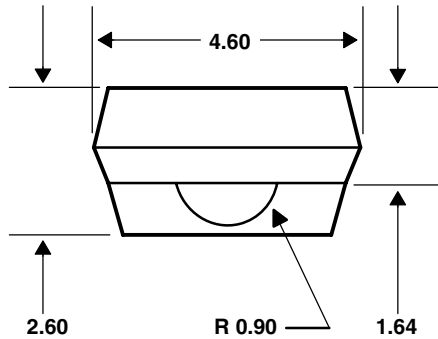

FRONT VIEW

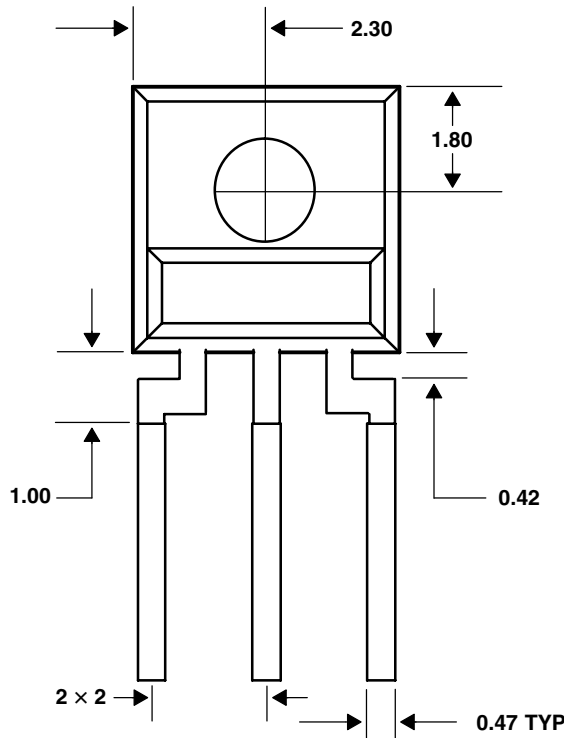

SIDE VIEW

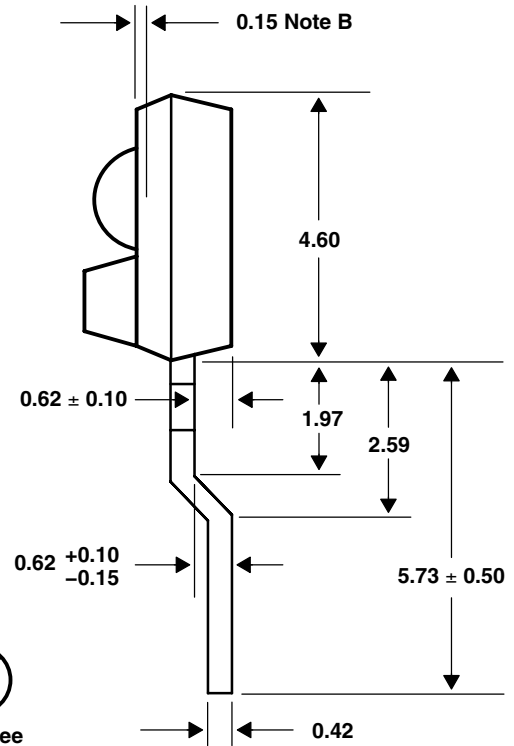

- NOTES: A. All linear dimensions are in millimeters; tolerance is ± 0.25 mm unless otherwise stated.
 B. Dimension is to center of lens arc, which is located below the package face.
 C. The integrated photodiode active area is typically located in the center of the lens and 0.97 mm below the top of the lens surface.
 D. Index of refraction of clear plastic is 1.55.
 E. Lead finish for TSL237SM-LF: solder dipped, 100% Sn.
 F. This drawing is subject to change without notice.

Figure 12. Package SM — Surface Mount Side-Looker Package Configuration

PRODUCTION DATA — information in this document is current at publication date. Products conform to specifications in accordance with the terms of Texas Advanced Optoelectronic Solutions, Inc. standard warranty. Production processing does not necessarily include testing of all parameters.

LEAD-FREE (Pb-FREE) and GREEN STATEMENT

Pb-Free (RoHS) TAOS' terms *Lead-Free* or *Pb-Free* mean semiconductor products that are compatible with the current RoHS requirements for all 6 substances, including the requirement that lead not exceed 0.1% by weight in homogeneous materials. Where designed to be soldered at high temperatures, TAOS Pb-Free products are suitable for use in specified lead-free processes.

Green (RoHS & no Sb/Br) TAOS defines *Green* to mean Pb-Free (RoHS compatible), and free of Bromine (Br) and Antimony (Sb) based flame retardants (Br or Sb do not exceed 0.1% by weight in homogeneous material).

Important Information and Disclaimer The information provided in this statement represents TAOS' knowledge and belief as of the date that it is provided. TAOS bases its knowledge and belief on information provided by third parties, and makes no representation or warranty as to the accuracy of such information. Efforts are underway to better integrate information from third parties. TAOS has taken and continues to take reasonable steps to provide representative and accurate information but may not have conducted destructive testing or chemical analysis on incoming materials and chemicals. TAOS and TAOS suppliers consider certain information to be proprietary, and thus CAS numbers and other limited information may not be available for release.

NOTICE

Texas Advanced Optoelectronic Solutions, Inc. (TAOS) reserves the right to make changes to the products contained in this document to improve performance or for any other purpose, or to discontinue them without notice. Customers are advised to contact TAOS to obtain the latest product information before placing orders or designing TAOS products into systems.

TAOS assumes no responsibility for the use of any products or circuits described in this document or customer product design, conveys no license, either expressed or implied, under any patent or other right, and makes no representation that the circuits are free of patent infringement. TAOS further makes no claim as to the suitability of its products for any particular purpose, nor does TAOS assume any liability arising out of the use of any product or circuit, and specifically disclaims any and all liability, including without limitation consequential or incidental damages.

TEXAS ADVANCED OPTOELECTRONIC SOLUTIONS, INC. PRODUCTS ARE NOT DESIGNED OR INTENDED FOR USE IN CRITICAL APPLICATIONS IN WHICH THE FAILURE OR MALFUNCTION OF THE TAOS PRODUCT MAY RESULT IN PERSONAL INJURY OR DEATH. USE OF TAOS PRODUCTS IN LIFE SUPPORT SYSTEMS IS EXPRESSLY UNAUTHORIZED AND ANY SUCH USE BY A CUSTOMER IS COMPLETELY AT THE CUSTOMER'S RISK.

LUMENOLOGY, TAOS, the TAOS logo, and Texas Advanced Optoelectronic Solutions are registered trademarks of Texas Advanced Optoelectronic Solutions Incorporated.

TSL237
HIGH-SENSITIVITY
LIGHT-TO-FREQUENCY CONVERTER
TAOS052J – SEPTEMBER 2008

Компания «Океан Электроники» предлагает заключение долгосрочных отношений при поставках импортных электронных компонентов на взаимовыгодных условиях!

Наши преимущества:

- Поставка оригинальных импортных электронных компонентов напрямую с производств Америки, Европы и Азии, а так же с крупнейших складов мира;
- Широкая линейка поставок активных и пассивных импортных электронных компонентов (более 30 млн. наименований);
- Поставка сложных, дефицитных, либо снятых с производства позиций;
- Оперативные сроки поставки под заказ (от 5 рабочих дней);
- Экспресс доставка в любую точку России;
- Помощь Конструкторского Отдела и консультации квалифицированных инженеров;
- Техническая поддержка проекта, помощь в подборе аналогов, поставка прототипов;
- Поставка электронных компонентов под контролем ВП;
- Система менеджмента качества сертифицирована по Международному стандарту ISO 9001;
- При необходимости вся продукция военного и аэрокосмического назначения проходит испытания и сертификацию в лаборатории (по согласованию с заказчиком);
- Поставка специализированных компонентов военного и аэрокосмического уровня качества (Xilinx, Altera, Analog Devices, Intersil, Interpoint, Microsemi, Actel, Aeroflex, Peregrine, VPT, Syfer, Eurofarad, Texas Instruments, MS Kennedy, Miteq, Cobham, E2V, MA-COM, Hittite, Mini-Circuits, General Dynamics и др.);

Компания «Океан Электроники» является официальным дистрибьютором и эксклюзивным представителем в России одного из крупнейших производителей разъемов военного и аэрокосмического назначения «JONHON», а так же официальным дистрибьютором и эксклюзивным представителем в России производителя высокотехнологичных и надежных решений для передачи СВЧ сигналов «FORSTAR».



JONHON

«JONHON» (основан в 1970 г.)

Разъемы специального, военного и аэрокосмического назначения:

(Применяются в военной, авиационной, аэрокосмической, морской, железнодорожной, горно- и нефтедобывающей отраслях промышленности)

«FORSTAR» (основан в 1998 г.)

ВЧ соединители, коаксиальные кабели,
кабельные сборки и микроволновые компоненты:

(Применяются в телекоммуникациях гражданского и специального назначения, в средствах связи, РЛС, а так же военной, авиационной и аэрокосмической отраслях промышленности).



Телефон: 8 (812) 309-75-97 (многоканальный)

Факс: 8 (812) 320-03-32

Электронная почта: ocean@oceanchips.ru

Web: <http://oceanchips.ru/>

Адрес: 198099, г. Санкт-Петербург, ул. Калинина, д. 2, корп. 4, лит. А