

MACX MCR-EX-SD-21-25-LP(-SP)



Intrinsically safe solenoid driver for Group IIC gases, loop-powered, current limit 25 mA

INTERFACE

Data sheet
103466_en_00

© PHOENIX CONTACT - 08/2008

1 Description

The solenoid driver **MACX MCR-EX-SD-21-25-LP(-SP)** has been designed for controlling intrinsically safe solenoid valves, alarm transmitters and indicators installed in the Ex area.

The intrinsically safe output circuit has a linear characteristic curve and is limited to 25 mA.

The required power is supplied via the control signal on the input side.

The input and the output are electrically isolated from each other.

The devices can be installed in zone 2 with the "n" (EN 60079-15) protection type.

1.1 Properties

- Single-channel
- Loop-powered
- Current limit 25 mA
- Output [Ex ia] IIC
- Installation in zone 2
- 2-way electrical isolation
- SIL 3 according to EN 61508
- With screw
(MACX MCR-EX-SD-21-25-LP)
or spring-cage connection
(MACX MCR-EX-SD-21-25-LP-SP)



WARNING: Explosion hazard

The device is an associated item of electrical equipment for intrinsically safe circuits. It is designed for use in zone 2, if specific conditions are observed.

When installing and operating the device, the applicable safety directives (including national safety directives), accident prevention regulations, as well as general technical regulations, must be observed.



WARNING: Explosion hazard

Be sure to observe the safety regulations and installation notes on page 5.



Make sure you always use the latest documentation.
It can be downloaded at www.download.phoenixcontact.com.

A conversion table is available on the Internet at
www.download.phoenixcontact.com/general/7000_en_00.pdf.



This data sheet is valid for all products listed on the following page:

Table of contents

1	Description.....	1
2	Ordering data.....	2
3	Technical data	2
4	Safety regulations and installation notes.....	5
5	Installation	6
6	Comparison of safety data	7
7	Calculating a valve circuit	8
8	Safety-related applications (SIL 3).....	9
9	Appendix	9

2 Ordering data

Ex solenoid driver

Description	Type	Order No.	Pcs./Pkt.
Intrinsically safe solenoid driver for Group IIC gases, loop-powered, current limit 25 mA, with screw connection	MACX MCR-EX-SD-21-25-LP	2865492	1
Intrinsically safe solenoid driver for Group IIC gases, loop-powered, current limit 25 mA, with spring-cage connection	MACX MCR-EX-SD-21-25-LP-SP	2924113	1

3 Technical data

Input

Input voltage	20 V DC ... 30 V DC
Input current	10 mA ... 70 mA (45 mA for $U_g = 24$ V DC)

Output

Output	Intrinsically safe, designed for protection type Ex-i [Ex ia] IIC
Current limit I_V ($I_V =$ maximum current, see page 8)	25 mA
Output voltage	5.5 V DC (at 25 mA)
No-load voltage U_V	21.4 V DC
Internal resistance R_i	641 Ω
Short-circuit-proof	Yes
Response time	20 ms
Output characteristic curve (see Figure 1 on page 3)	

Output characteristic curve

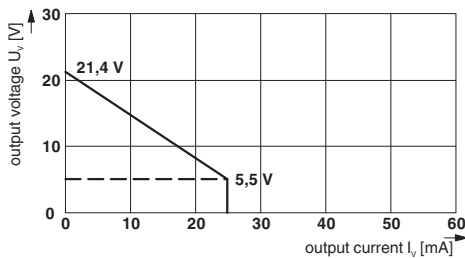

Figure 1 Output characteristic curve for MACX MCR-EX-SD-21-25-LP(-SP)

General data

Supply voltage type	Loop-powered
Power dissipation	< 1 W
Maximum temperature coefficient	0.01%/K
Electrical isolation according to EN 61010	300 V _{rms} (rated insulation voltage, surge voltage category II, pollution degree 2, safe isolation as per EN 61010, EN 50178)
Input/output	
Electrical isolation according to EN 60079-11	375 V (peak value according to EN 60079-11)
Input/output	
Test voltage	2.5 kV AC (50 Hz, 1 min., test voltage)
Input/output	
Ambient temperature (operation)	-20°C ... +60°C (any mounting position)
Ambient temperature (storage/transport)	-40°C ... +80°C
Permissible humidity (operation)	10% ... 95% (no condensation)
Status indicator	Yellow LED (switching state/status, lights up when output circuit is active)
Degree of protection	IP20
Housing material	PBT
Color	Green
Width x length x height	12.5 mm x 114.5 mm x 104 mm (with connection terminal block)
Inflammability class according to UL 94	V0

Conformance

EMC directive 2004/108/EC	EN 61000-6-2, EN 61000-6-4, EN 61326-1
Ex directive (ATEX)	EN 60079-0, EN 60079-11, EN 60079-15

Safety data according to ATEX for intrinsically safe circuits

Maximum output voltage U_o	25.1 V		
Maximum output current I_o	39 mA		
Maximum output power P_o	245 mW		
Gas group	IIA	IIB	IIC
Maximum external inductance L_o	266 mH	133 mH	32 mH
Maximum external capacitance C_o	2.9 μ F	0.8 μ F	0.1 μ F
Safety-related maximum voltage U_m	253 V AC (125 V DC)		

Certificates

UL/CUL	UL applied for
ATEX	Ex II (1) GD [Ex ia] IIC, IIB, IIA IBExU 07 ATEX 1133
IECEX approval	IECEX applied for
UL USA/Canada	UL applied for
Functional safety (SIL)	SIL 3 according to EN 61508

Connection data MACX MCR-EX-SD-21-25-LP

Conductor cross-section	
Solid (minimum/maximum)	0.2 mm ² /2.5 mm ²
Stranded (minimum/maximum)	0.2 mm ² /2.5 mm ²
AWG/kcmil (minimum/maximum)	24/14
Stripping length	7 mm
Thread	M 3
Connection method	Pluggable screw connection
Tightening torque	0.5 Nm, minimum/0.6 Nm, maximum

Connection data MACX MCR-EX-SD-21-25-LP-SP

Conductor cross-section	
Solid (minimum/maximum)	0.2 mm ² /1.5 mm ²
Stranded (minimum/maximum)	0.2 mm ² /1.5 mm ²
AWG/kcmil (minimum/maximum)	24/16
Stripping length	8 mm
Connection method	Spring-cage connection

4 Safety regulations and installation notes

4.1 Installation and operation

Follow the installation instructions.



NOTE: Installation, operation, and maintenance may only be carried out by qualified specialist personnel.

When installing and operating the device, the applicable safety directives (including national safety directives), accident prevention regulations, as well as general technical regulations must be observed.



NOTE: The circuits inside the device must not be accessed.

Do not repair the device yourself, but replace it with an equivalent device. Repairs may only be carried out by the manufacturer.



NOTE: The device is designed to meet IP20 protection when:

- It is installed outside potentially explosive areas.
- The environment is clean and dry.

Install the device in a suitable housing with a suitable degree of protection in accordance with IEC 60529 in order to protect it from mechanical and electrical damage.

For the safety data, please refer to the operating instructions and certificates (EC type-examination, other approvals, if necessary).

4.2 Safety regulations for installation in potentially explosive areas

Regulations for intrinsically safe circuits



WARNING: Explosion hazard
When carrying out **measurements** on the intrinsically safe side, be sure to observe the relevant regulations regarding the connection of intrinsically safe equipment.
Only use devices approved for use in intrinsically safe circuits.



WARNING: Explosion hazard
If the **device has been used in non-intrinsically safe circuits**, it must **not** be used again in intrinsically safe circuits. Clearly label the module as being non-intrinsically safe.

Installation in Zone 2



WARNING: Explosion hazard
The device is associated equipment of the "Ex-i" protection type and suitable for installation in Zone 2.

Observe the specified conditions for use in potentially explosive areas.



WARNING: Explosion hazard
Install the device in suitable **housing with a minimum of IP54 degree of protection**. Observe the requirements of IEC 60079-14/EN 60079-14, e.g., steel housing with a wall thickness of 3 mm.



WARNING: Explosion hazard
Disconnect the block **power supply before**:

- Snapping it on or disconnecting it.
- Connecting or disconnecting cables of non-intrinsically safe circuits.



WARNING: Explosion hazard
Only use category 3G MACX MCR-EX modules (ATEX 94/9/EC).

Installation in areas with a danger of dust explosions



WARNING: Explosion hazard
The device is **not** designed for installation in areas with a danger of dust explosions.

Connection to the **intrinsically safe circuit in areas with a danger of dust explosions** (zones 20, 21, and 22) is **only** permitted if the equipment connected to this circuit is approved for this zone (e.g., category 1D, 2D or 3D).

4.3 Use in safety-related applications (SIL 3)

When using the MACX MCR-EX-SD-21-25-LP(-SP) in safety-related applications, observe the instructions in Section 8, as the requirements differ for safety-related functions.

5 Installation



NOTE: Electrostatic discharge

The device contains components that can be damaged or destroyed by electrostatic discharge. When handling the device, observe the necessary safety precautions against electrostatic discharge (ESD) according to EN 61340-5-1 and EN 61340-5-2.

5.1 Basic circuit diagram



Figure 2 Basic circuit diagram with connection terminal blocks

5.2 Design

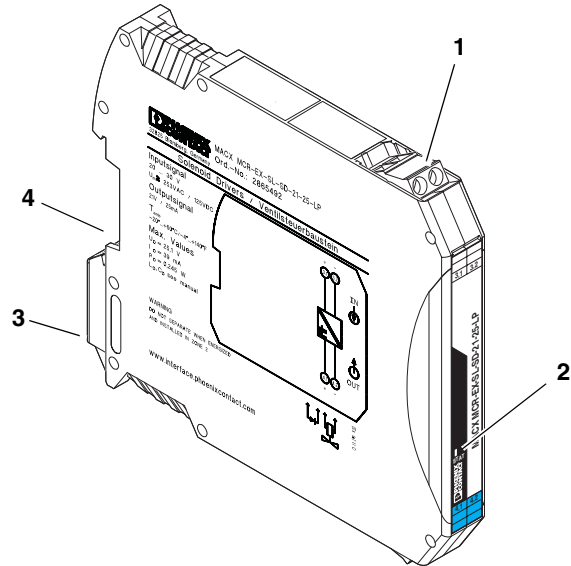

Figure 3 Design MACX MCR-EX-SD-21-25-LP

- 1 Pluggable COMBICON screw terminal blocks (for MACX MCR-EX-SD-21-25-LP-SP with spring-cage terminal blocks)
- 2 LED STAT, status display, lights up when output active
- 3 Metal lock for fixing on the DIN rail
- 4 Connection options for DIN rail connector

5.3 Dimensions

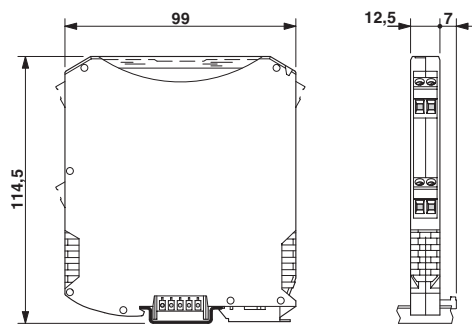

Figure 4 Dimensions (in mm)

5.4 Mounting



WARNING: Explosion hazard

If the device has been used in **non-intrinsically safe circuits**, it must **not** be used again in intrinsically safe circuits. Clearly label the module as being non-intrinsically safe.

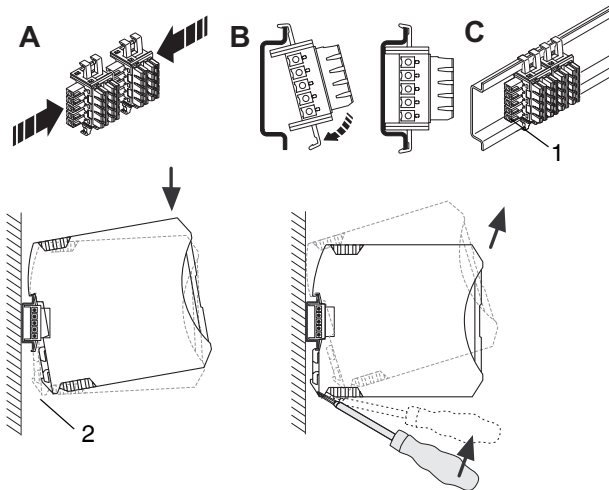

Figure 5 Mounting and removing

- Mount the device on a 35 mm DIN rail according to EN 60715.
- When using a DIN rail connector (ME 6.2 TBUS-... , Order No. 2869728), insert this into the DIN rail first. This is used for error messages.
Please also ensure you observe the direction of the module and DIN rail connector when snapping into position:
Snap-on foot below (2) and connector left (1).
- The device is loop-powered and so does not require its own power supply.
It can, however, be snapped in isolation onto a DIN rail connector that supplies power to non-loop-powered MACX MCR-EX modules.
- Install the module in suitable housing to meet the requirements for the protection class.
- Before startup, check that the solenoid driver is operating and wired correctly, especially with regard to the wiring and labeling of the intrinsically safe circuits.

5.5 Connecting the cables

- Pluggable screw terminal blocks (on MACX MCR-EX-SD-21-25-LP); litz wires provided with ferrules.
- Pluggable spring-cage terminal blocks (on MACX MCR-EX-SD-21-25-LP-SP); litz wires provided with ferrules.
- Lay intrinsically safe and non-intrinsically safe cables separately.
- Permissible cable cross-section: 0.2 mm² to 2.5 mm².
- **Screw connection:**
 - Insert the wire into the corresponding connection terminal block.
 - Use a screwdriver to tighten the screw in the opening above the connection terminal block.
- **Spring-cage connection:**
 - Insert a screwdriver in the opening above the connection terminal block.
 - Insert the wire into the corresponding connection terminal block.

6 Comparison of safety data



WARNING: Explosion hazard

Compare the safety data before connecting a device located in the intrinsically safe area to the MACX MCR-EX-SD-21-25-LP(-SP).

Safety data for

Field devices: U_i, I_i, P_i, L_i, C_i

Solenoid drivers: U_o, I_o, P_o, L_o, C_o

For the values for U_o, I_o, P_o, L_o and C_o , please refer to "Safety data according to ATEX for intrinsically safe circuits" on page 3 and the EC type-examination certificate.

Requirements for intrinsic safety (simple circuits):

$$U_i \geq U_o$$

$$I_i \geq I_o$$

$$P_i \geq P_o$$

$$L_i + L_c \leq L_o$$

$$C_i + C_c \leq C_o$$

(L_c and C_c are dependent on the cables/lines used.)

7 Calculating a valve circuit



Figure 6 Equivalent circuit

In order to connect a solenoid valve to the device, it is also necessary calculate the measurements in addition to comparing the safety data.

- R_i : Internal resistance of solenoid driver
- U_V : Guaranteed voltage of the solenoid driver without load
- I_V : Maximum current that can be supplied by the solenoid driver
- R_C : Maximum permissible cable resistance when connecting the solenoid driver and valve
- R_{SV} : Effective coil resistance of the solenoid valve (the copper resistance of the coil depends on the temperature)
- I_{SV} : The current required by the solenoid coil so that the valve can close tightly
- U_{SV} : The voltage which is applied across the coil with I_{SV}

R_{SV} and U_{SV} are determined by the copper resistance, which depends on the ambient temperature.

The values of R_{SV} and I_{SV} must be obtained from the valve manufacturer. The values for R_i and U_V can be found in the technical data under "Output" on page 2.

On the basis of this, the permissible cable resistance can be calculated according to the formula below:

$$R_C = \frac{U_V}{I_{SV}} - R_i - R_{SV}$$

Recommendation:
For R_C , an actual cable resistance of +25 Ω should be calculated.

In the event of a negative resistance, a successful connection is no longer guaranteed.

Function requirements: $I_V \geq I_{SV}$ and $R_C > 0 \Omega$.



You can obtain a list of suitable valves from the Download Center at www.download.phoenixcontact.com.

8 Safety-related applications (SIL 3)

8.1 Response times

Following a state change at the input, the output enters the safe state in ≤ 20 ms.

8.2 Operating mode of the safety function

Operating mode as per EN 61508: "Low demand mode"

8.3 Failure behavior and required response

1. The safe state is entered in the event of an input voltage failure.
2. The safe state is reached by removing the device's connection terminal blocks.

8.4 Safety integrity requirements

Failure rates

- Type A device (according to EN 61508-2)
- Safety Integrity Level (SIL) 3

λ_{SAFE}	$\lambda_{\text{DANGEROUS}}$	SFF ¹	DC _S ²	DC _D ²
284 FIT ³	0 FIT	100%	0%	0%

¹ SFF = Safe Failure Fraction

² DC = Diagnostic Coverage (safe or dangerous)

³ FIT = Failure in Time (1 FIT = 1 failure/10⁹ h)

PFD_{AVG} values

T[PROOF] =	1 year	5 years	10 years
PFD _{AVG} ¹ =	0	0	0

¹ PFD = Probability of Failure on Demand

Since the PFD_{AVG} value is 0, it is not necessary to perform regular proof tests. This is, however, still recommended (see Section 8.5).

Failure limit

The operating mode is based on low demand mode. The percentage of the device at PFH/PFD for the overall safety loop is 10%.

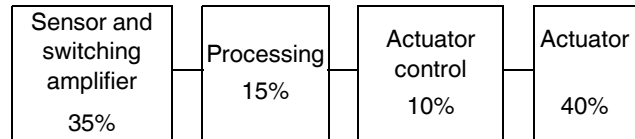

Figure 7 Safety loop

Conditions

- The failure rates of the components used remain constant throughout the period of use.
- Propagation of errors by the device in the system is not taken into consideration.
- The repair time (= replacement) should take eight hours.
- The failure rates of the external signaling device are not taken into consideration.
- The average temperature at which the device is to be used is +40°C. This is based on standard industrial conditions.

8.5 Proof Test

Even where the PFD_{AVG} value is 0, it is still recommended that you check the function of the valve burner in conjunction with the entire safety loop.

1. Take appropriate steps to prevent incorrect use. Prevent other areas of the system from being affected by the proof test (e.g., set the control system to test mode).
2. When a voltage of between 20 V and 30 V is applied at the input, check whether a voltage of > 0 can be measured at the output terminal blocks. The field device must switch at the same time.
3. Restore the safety circuit to full functionality.
4. Return to normal operation.

9 Appendix

Exida assessment summary (3 pages)



Failure Modes, Effects and Diagnostic Analysis

Project:

Solenoid Driver with Motherboard

Customer:

Phoenix Contact GmbH & Co. KG
Blomberg
Germany

Contract No.: Phoenix Contact 06/06-05
Report No.: Phoenix Contact 06/06-05 R004
Version V1, Revision R0, September 2006
Philipp Neumeier

Management summary

This report summarizes the results of the hardware assessment carried out on the solenoid drivers type PI-EX-SD-**-** with a corresponding motherboard and on the solenoid drivers with top hat rail design, MACX MCR-EX-SL-SD-**-**-LP.

Table 1 gives an overview of the different devices. Within each type the different devices have the same circuit diagram.

Table 1: Device overview

Motherboard type:	Top hat rail type:	Output values:
PI-EX-SD-21-25	MACX MCR-EX-SL-SD-21-25-LP	21 V / 25 mA
PI-EX-SD-21-45	MACX MCR-EX-SL-SD-21-45-LP	21 V / 45 mA
PI-EX-SD-24-48	MACX MCR-EX-SL-SD-24-48-LP	24 V / 48 mA
PI-EX-SD-21-60	MACX MCR-EX-SL-SD-21-60-LP	21 V / 60 mA

The hardware assessment consists of a Failure Modes, Effects and Diagnostics Analysis (FMEDA). A FMEDA is one of the steps taken to achieve functional safety assessment of a device per IEC 61508. From the FMEDA, failure rates are determined and consequently the Safe Failure Fraction (SFF) is calculated for the device. For full assessment purposes all requirements of IEC 61508 must be considered.

The failure rates used in this analysis are the basic failure rates from the Siemens standard SN 29500.

According to table 2 of IEC 61508-1 the average PFD for systems operating in low demand mode has to be $\geq 10^{-4}$ to $< 10^{-3}$ for SIL 3 safety functions. However, as the modules under consideration are only one part of an entire safety function they should not claim more than 10% of this range, i.e. they should be better than or equal to 1,00E-04.

The solenoid drivers type PI-EX-SD-**-** with a corresponding motherboard and the solenoid drivers with top hat rail design, MACX MCR-EX-SL-SD-**-**-LP are considered to be Type A¹ components with a hardware fault tolerance of 0.

For Type A components the SFF has to be 90% to < 99% according to table 2 of IEC 61508-2 for SIL 3 (sub-) systems with a hardware fault tolerance of 0.

The solenoid drivers PI-EX-SD-**-** and MACX MCR-EX-SL-SD-**-**-LP are operated in passive mode, and can therefore be regarded as loop powered modules. Because loop powered modules are directly driven from the digital output of a safety PLC there is no additional power supply which can keep the output energized in case of an internal fault. Thus all internal faults have either no effect on the safety function or lead to a safe state.

¹ Type A component: "Non-complex" component (all failure modes are well defined); for details see 7.4.3.1.2 of IEC 61508-2.

Results for solenoid drivers PI-EX-SD-**-** with Motherboard:

The following table shows how the above stated requirements are fulfilled.

Table 2: Summary for PI-EX-SD--** with Motherboard – IEC 61508 failure rates ²**

λ_{SAFE}	$\lambda_{DANGEROUS}$	SFF	PFD _{AVG}
284 FIT	0 FIT ³	100%	0,00E+00

Results for top hat rail type solenoid drivers MACX MCR-EX-SL-SD-**-**-LP:

The following table shows how the above stated requirements are fulfilled.

Table 3: Summary for MACX MCR-EX-SL-SD--**-LP – IEC 61508 failure rates ²**

λ_{SAFE}	$\lambda_{DANGEROUS}$	SFF	PFD _{AVG}
282FIT	0 FIT ³	100%	0,00E+00

The above results show that the solenoid drivers PI-EX-SD-**-** with Motherboard and MACX MCR-EX-SL-SD-**-**-LP - both when loop powered - can be used for all safety applications.

The calculations are based on the assumption that the devices are mounted in an environment that is IP 54 compliant (e.g. housing, control cabinet or control room).

The failure rates are valid for the useful life of the solenoid drivers PI-EX-SD-**-** and MACX MCR-EX-SL-SD-**-**-LP (see Appendix 1).

² It is assumed that practical fault insertion tests can demonstrate the correctness of the failure effects assumed during the FMEDAs.

³ In order to deal with the excluded faults in the quantitative analysis it might be reasonable to consider a dangerous failure rate of 0.1 FIT, leading to a SFF of 99,97% and a PFD_{AVG} of 4,38E-06 for a proof time of 10 years.

Компания «Океан Электроники» предлагает заключение долгосрочных отношений при поставках импортных электронных компонентов на взаимовыгодных условиях!

Наши преимущества:

- Поставка оригинальных импортных электронных компонентов напрямую с производств Америки, Европы и Азии, а так же с крупнейших складов мира;
- Широкая линейка поставок активных и пассивных импортных электронных компонентов (более 30 млн. наименований);
- Поставка сложных, дефицитных, либо снятых с производства позиций;
- Оперативные сроки поставки под заказ (от 5 рабочих дней);
- Экспресс доставка в любую точку России;
- Помощь Конструкторского Отдела и консультации квалифицированных инженеров;
- Техническая поддержка проекта, помощь в подборе аналогов, поставка прототипов;
- Поставка электронных компонентов под контролем ВП;
- Система менеджмента качества сертифицирована по Международному стандарту ISO 9001;
- При необходимости вся продукция военного и аэрокосмического назначения проходит испытания и сертификацию в лаборатории (по согласованию с заказчиком);
- Поставка специализированных компонентов военного и аэрокосмического уровня качества (Xilinx, Altera, Analog Devices, Intersil, Interpoint, Microsemi, Actel, Aeroflex, Peregrine, VPT, Syfer, Eurofarad, Texas Instruments, MS Kennedy, Miteq, Cobham, E2V, MA-COM, Hittite, Mini-Circuits, General Dynamics и др.);

Компания «Океан Электроники» является официальным дистрибьютором и эксклюзивным представителем в России одного из крупнейших производителей разъемов военного и аэрокосмического назначения «JONHON», а так же официальным дистрибьютором и эксклюзивным представителем в России производителя высокотехнологичных и надежных решений для передачи СВЧ сигналов «FORSTAR».



JONHON

«JONHON» (основан в 1970 г.)

Разъемы специального, военного и аэрокосмического назначения:

(Применяются в военной, авиационной, аэрокосмической, морской, железнодорожной, горно- и нефтедобывающей отраслях промышленности)

«FORSTAR» (основан в 1998 г.)

ВЧ соединители, коаксиальные кабели, кабельные сборки и микроволновые компоненты:

(Применяются в телекоммуникациях гражданского и специального назначения, в средствах связи, РЛС, а так же военной, авиационной и аэрокосмической отраслях промышленности).



Телефон: 8 (812) 309-75-97 (многоканальный)

Факс: 8 (812) 320-03-32

Электронная почта: ocean@oceanchips.ru

Web: <http://oceanchips.ru/>

Адрес: 198099, г. Санкт-Петербург, ул. Калинина, д. 2, корп. 4, лит. А