

Quad High Side Micropower MOSFET Driver with Internal Charge Pump

FEATURES

- No External Charge Pump Components
- Fully Enhances N-Channel Power MOSFETs
- 16 Microamps Standby Current
- 95 Microamps ON Current
- Wide Power Supply Range 4.5V to 18V
- Controlled Switching ON and OFF Times
- Replaces P-Channel High Side Switches
- Compatible with Standard Logic Families
- Available in 16-pin SOL Package

APPLICATIONS

- Laptop Computer Power Switching
- SCSI Termination Power Switching
- Cellular Telephone Power Management
- P-Channel Switch Replacement
- Battery Charging and Management
- Low Frequency H-Bridge Driver
- Stepper Motor and DC Motor Control

DESCRIPTION

The LTC1156 quad High side gate driver allows using low cost N-channel FETs for high side switching applications. An internal charge pump boosts the gate drive voltage above the positive rail, fully enhancing an N-channel MOS switch with no external components. Micropower operation, with 16 μ A standby current and 95 μ A operating current, allows use in virtually all systems with maximum efficiency.

Included on chip is independent over-current sensing to provide automatic shutdown in case of short circuits. A time delay can be added to the current sense to prevent false triggering on high in-rush current loads.

The LTC1156 operates off of a 4.5V to 18V supply and is well suited for battery-powered applications, particularly where micropower "sleep" operation is required.

The LTC1156 is available in both 16-pin DIP and 16-pin SOL packages.

TYPICAL APPLICATION

Laptop Computer Power Management

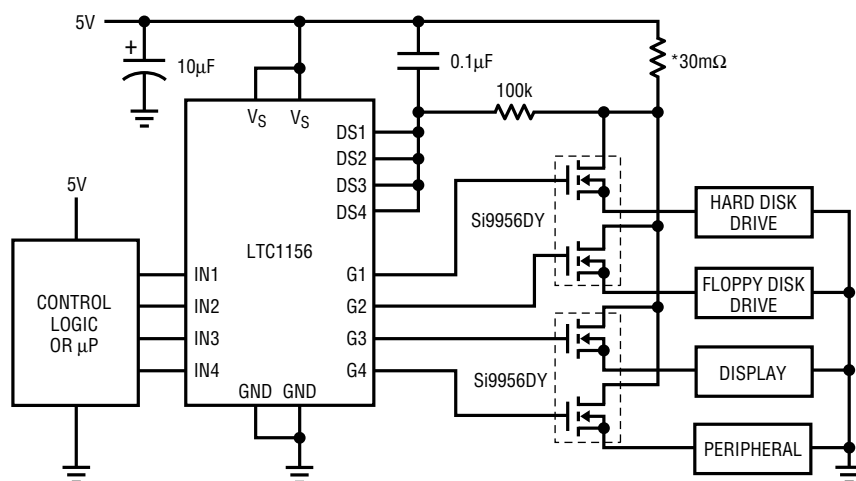

Standby Supply Current

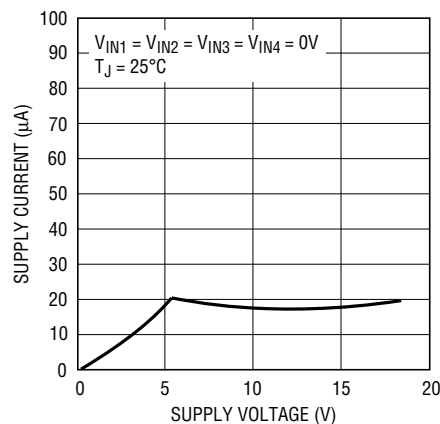

ALL COMPONENTS SHOWN ARE SURFACE MOUNT. MINIMUM PARTS COUNT SHOWN. CURRENT LIMITS CAN BE SET SEPARATELY AND TAILORED TO INDIVIDUAL LOAD CHARACTERISTICS.

* IMS026 INTERNATIONAL MANUFACTURING SERVICES, INC. (401) 683-9700

1156 TA01

ABSOLUTE MAXIMUM RATINGS

Supply Voltage	22V	Operating Temperature Range	
Input Voltage	($V_S + 0.3V$) to ($GND - 0.3V$)	LTC1156C	0°C to 70°C
Gate Voltage	($V_S + 24V$) to ($GND - 0.3V$)	Storage Temperature Range	-65°C to 150°C
Current (Any Pin)	50mA	Lead Temperature (Soldering, 10 sec.)	300°C

PACKAGE/ORDER INFORMATION

<p>N PACKAGE 16-LEAD PLASTIC DIP $T_{JMAX} = 110^{\circ}C, \theta_{JA} = 120^{\circ}C/W$</p>	<p>ORDER PART NUMBER</p> <p>LTC1156CN</p>	<p>S PACKAGE 16-LEAD PLASTIC SOL $T_{JMAX} = 110^{\circ}C, \theta_{JA} = 130^{\circ}C/W$</p>	<p>ORDER PART NUMBER</p> <p>LTC1156CS</p>
---	---	---	---

Consult factory for Industrial and Military grade parts.

ELECTRICAL CHARACTERISTICS $V_S = 4.5V$ to $18V, T_A = 25^{\circ}C$, unless otherwise noted.

SYMBOL	PARAMETER	CONDITIONS	MIN	TYP	MAX	UNITS
V_S	Supply Voltage	(Note 1)	●	4.5	18	V
I_Q	Quiescent Current OFF	$V_S = 5V, V_{IN} = 0V$ (Note 2)		16	40	μA
I_Q	Quiescent Current ON	$V_S = 5V, V_{IN} = 5V$ (Note 3)		95	125	μA
I_Q	Quiescent Current ON	$V_S = 12V, V_{IN} = 5V$ (Note 3)		180	400	μA
V_{INH}	Input High Voltage		●	2.0		V
V_{INL}	Input Low Voltage		●		0.8	V
I_{IN}	Input Current	$0V < V_{IN} < V_S$	●		± 1.0	μA
C_{IN}	Input Capacitance			5		pF
V_{SEN}	Drain Sense Threshold Voltage		●	80 75	100 100 120 125	mV mV
I_{SEN}	Drain Sense Input Current	$0V < V_{SEN} < V_S$	●		± 0.1	μA
$V_{GATE} - V_S$	Gate Voltage Above Supply	$V_S = 5V$ $V_S = 6V$ $V_S = 12V$	● ● ●	6.0 7.5 15	7.0 8.3 18 9.0 15.0 25	V V V
t_{ON}	Turn-ON Time	$V_S = 5V, C_{GATE} = 1000pF$ Time for $V_{GATE} > V_S + 2V$ Time for $V_{GATE} > V_S + 5V$		50 200	250 1100 750 2000	μs μs
		$V_S = 12V, C_{GATE} = 1000pF$ Time for $V_{GATE} > V_S + 5V$ Time for $V_{GATE} > V_S + 10V$		50 120	180 450 500 1200	μs μs

ELECTRICAL CHARACTERISTICS $V_S = 4.5V$ to $18V$, $T_A = 25^\circ C$, unless otherwise noted.

SYMBOL	PARAMETER	CONDITIONS	MIN	TYP	MAX	UNITS
t_{OFF}	Turn-OFF Time	$V_S = 5V$, $C_{GATE} = 1000pF$ Time for $V_{GATE} < 1V$	10	36	60	μs
		$V_S = 12V$, $C_{GATE} = 1000pF$ Time for $V_{GATE} < 1V$	10	26	60	μs
t_{SC}	Short Circuit Turn-OFF Time	$V_S = 5V$, $C_{GATE} = 1000pF$ Time for $V_{GATE} < 1V$	5	16	30	μs
		$V_S = 12V$, $C_{GATE} = 1000pF$ Time for $V_{GATE} < 1V$	5	16	30	μs

The ● denotes specifications which apply over the full operating temperature range.

Note 1: Both V_S pins (3 and 8) must be connected together, and both ground pins (1 and 6) must be connected together.

Note 2: Quiescent current OFF is for all channels in OFF condition.

Note 3: Quiescent current ON is per driver and is measured independently.

TYPICAL PERFORMANCE CHARACTERISTICS

Standby Supply Current

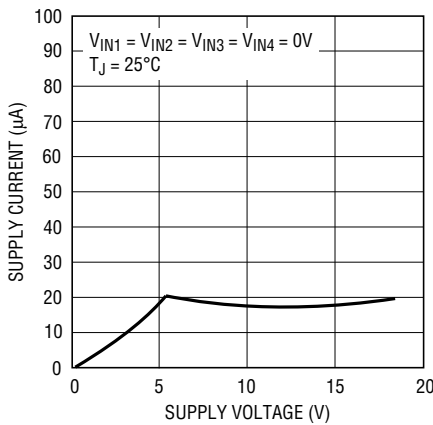

LTC1156 G01

Supply Current per Channel ON

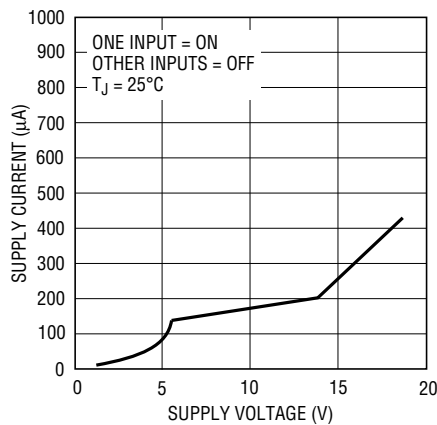

1156 G02

High Side Gate Voltage

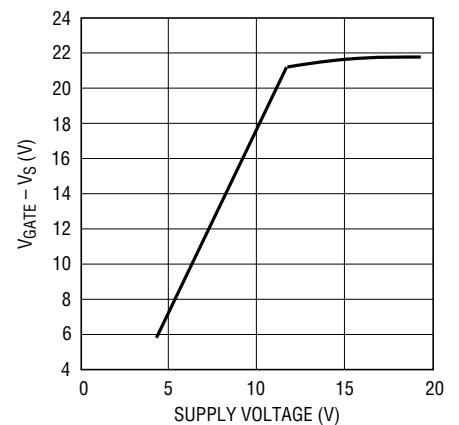

LTC1156 G03

Standby Supply Current

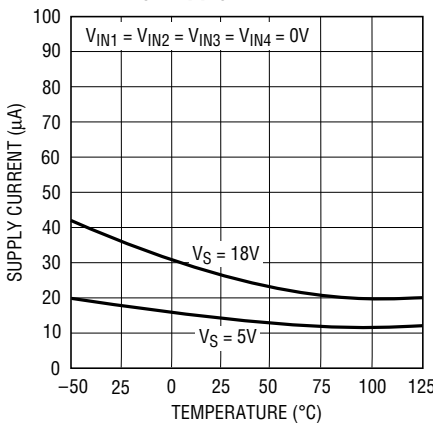

1156 G04

Supply Current per Channel ON

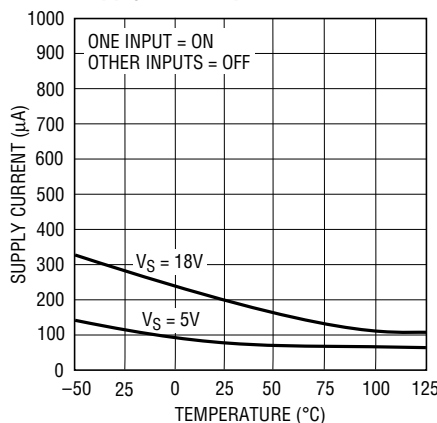

1156 G05

Low Side Gate Voltage

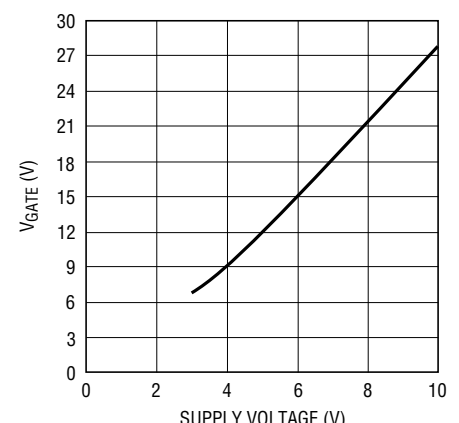

1156 G06

TYPICAL PERFORMANCE CHARACTERISTICS

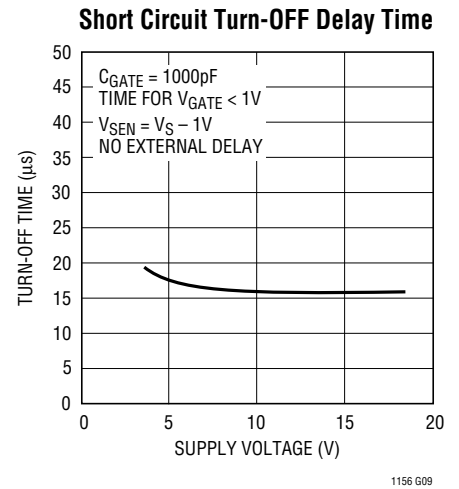
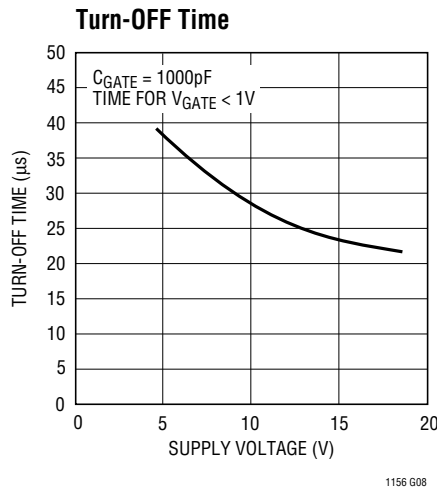
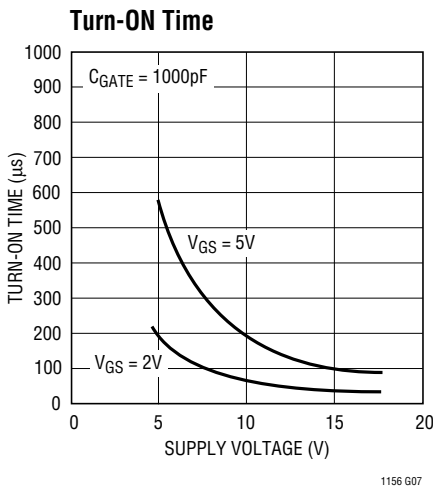

BLOCK DIAGRAM

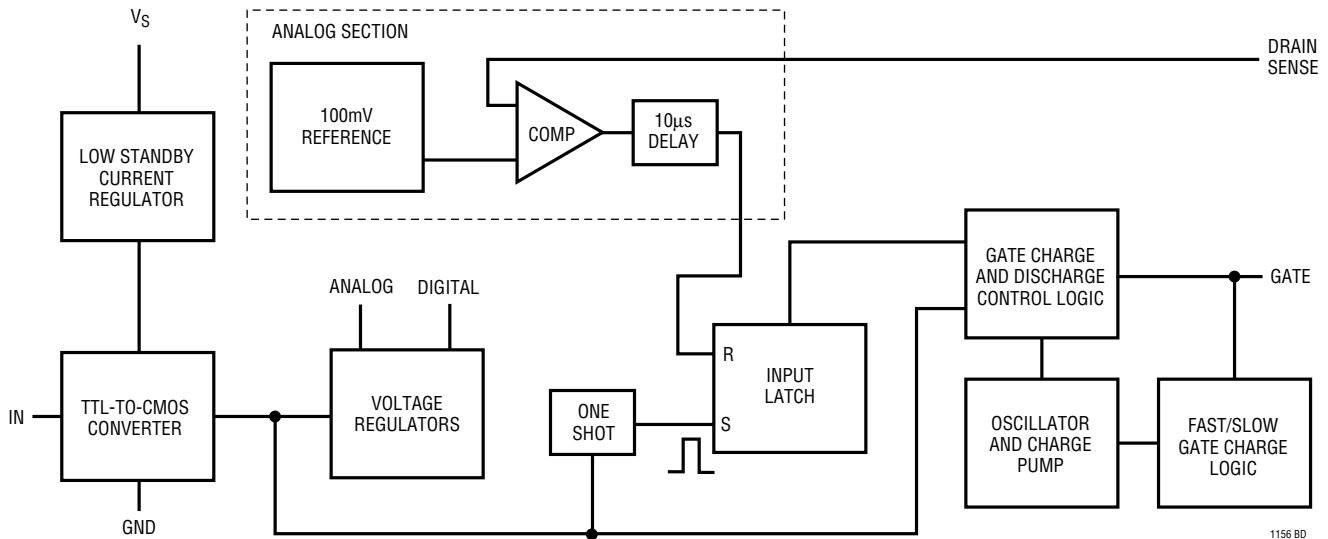

OPERATION

The LTC1156 contains four independent power MOSFET gate drivers and protection circuits (refer to the Block Diagram for detail). Each section of LTC1156 consists of the following functional blocks:

TTL and CMOS Compatible Inputs

Each driver input has been designed to accommodate a wide range of logic families. The input threshold is set at 1.3V with approximately 100mV of hysteresis.

OPERATION

A voltage regulator with low standby current provides continuous bias for the TTL to CMOS converters. The TTL to CMOS converter output enables the rest of the circuitry. In this way the power consumption is kept to a minimum in the standby mode.

Internal Voltage Regulation

The output of the TTL to CMOS converter drives two regulated supplies which power the low voltage CMOS logic and analog blocks. The regulator outputs are isolated from each other so that the noise generated by the charge pump logic is not coupled into the 100mV reference or the analog comparator.

Gate Charge Pump

Gate drive for the power MOSFET is produced by an adaptive charge pump circuit which generates a gate voltage substantially higher than the power supply voltage. The charge pump capacitors are included on chip and therefore no external components are required to generate the gate drive.

Drain Current Sense

The LTC1156 is configured to sense the drain current of the power MOSFET in high side applications. An internal 100mV reference is compared to the drop across a sense resistor (typically 0.002Ω to 0.1Ω) in series with the drain lead. If the drop across this resistor exceeds the internal 100mV threshold, the input latch is reset and the gate is quickly discharged by a large N-channel transistor. A simple RC network can be added to delay the over-current protection so that large in-rush current loads such as lamps or capacitors can be started.

Supply and Ground Pins

The two supply pins (3 and 8) of the LTC1156 must be connected together at all times and the two ground pins (1 and 6) must be connected together at all times. The two supply pins should be connected to the “top” of the drain current sense resistor/s to ensure accurate sensing.

For further applications information, see the LTC1155 Dual High Side Micropower MOSFET Driver data sheet.

TYPICAL APPLICATIONS

4-Cell Extremely Low Voltage Drop Regulator and Three Load Switches with Short-Circuit Protection and 20 μ A Standby Current

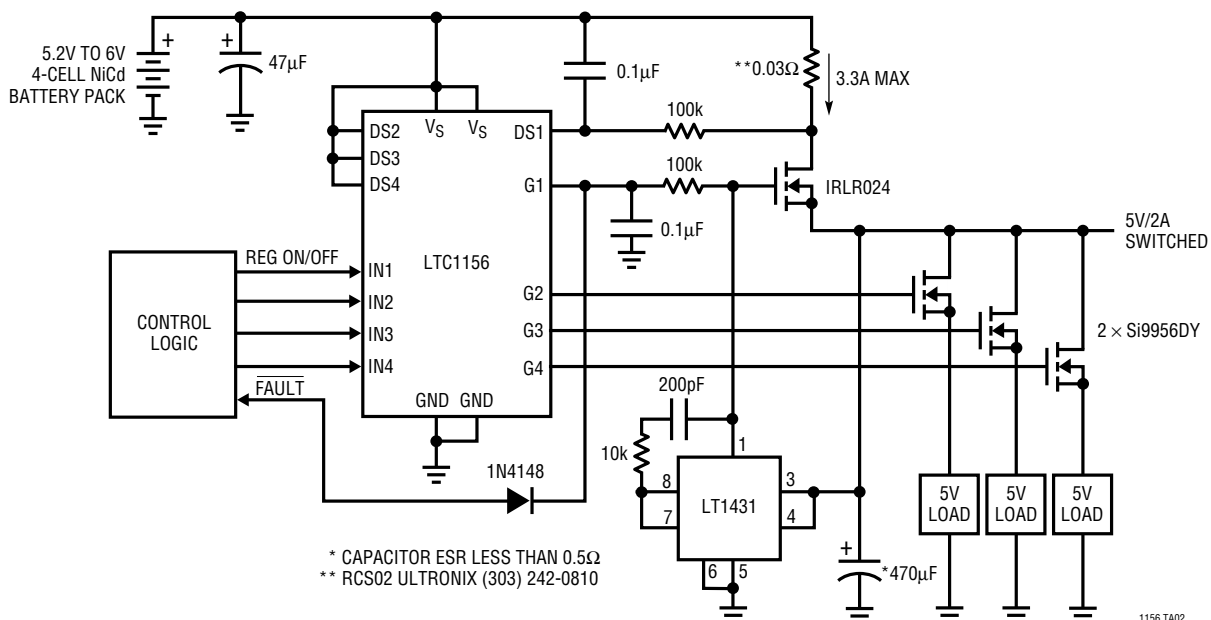

TYPICAL APPLICATIONS

24V to 30V Quad Industrial Switch with Thermal Shutdown

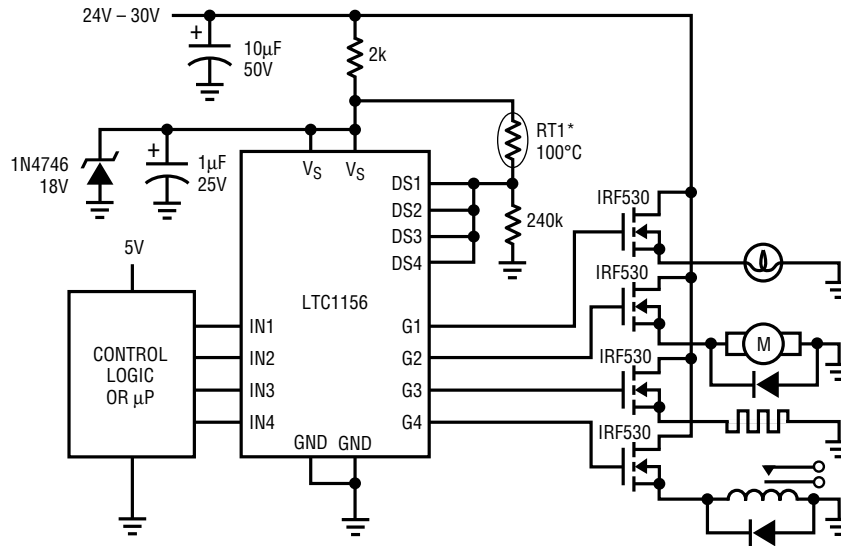

* KEYSTONE RL2006-100-100-30-PT MOUNT ON HEATSINK.

1156 TA03

Automotive Triple High Side Switch with Reverse Battery Interrupt, Short-Circuit and High-Voltage Transient Protection (20µA Standby Current)

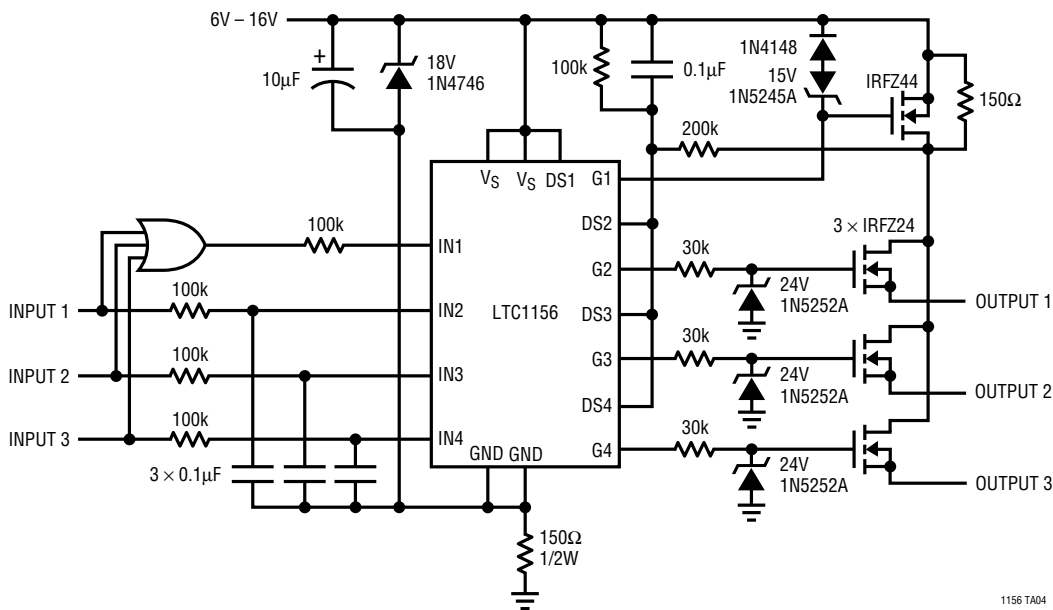

1156 TA04

TYPICAL APPLICATIONS

4-Phase Stepper Motor Driver with Short-Circuit Protection

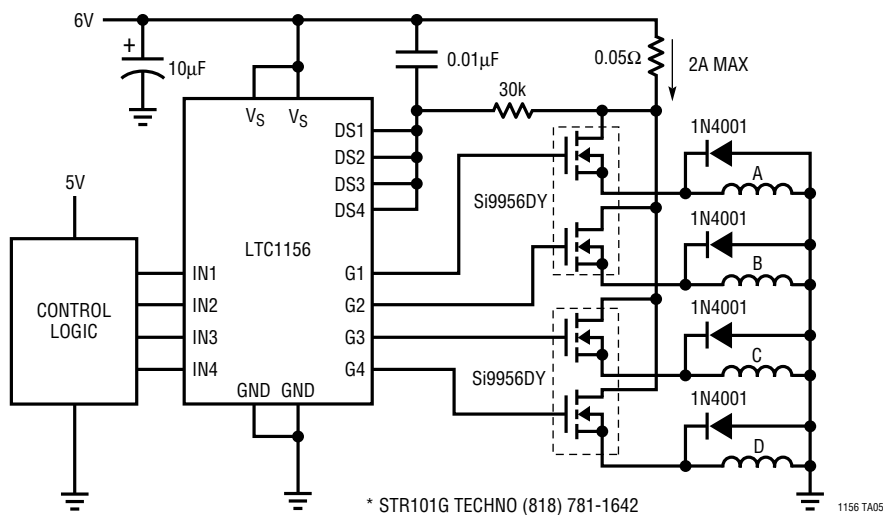
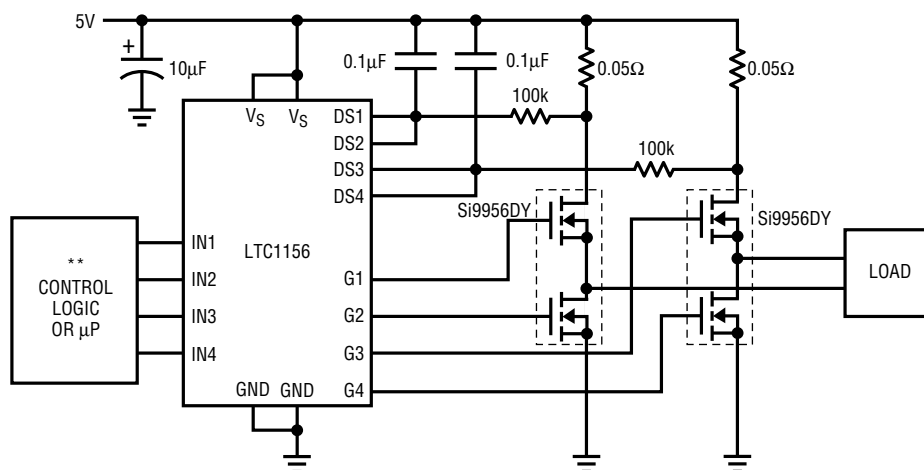
Full H-Bridge Driver with Short-Circuit Protection and 16µA Standby Current
Low Frequency Operation (<100Hz)

For more Typical Applications, see LTC1155 data sheet.

PACKAGE DESCRIPTION Dimensions in inches (millimeters) unless otherwise noted.

**N Package
16-Lead Plastic DIP**

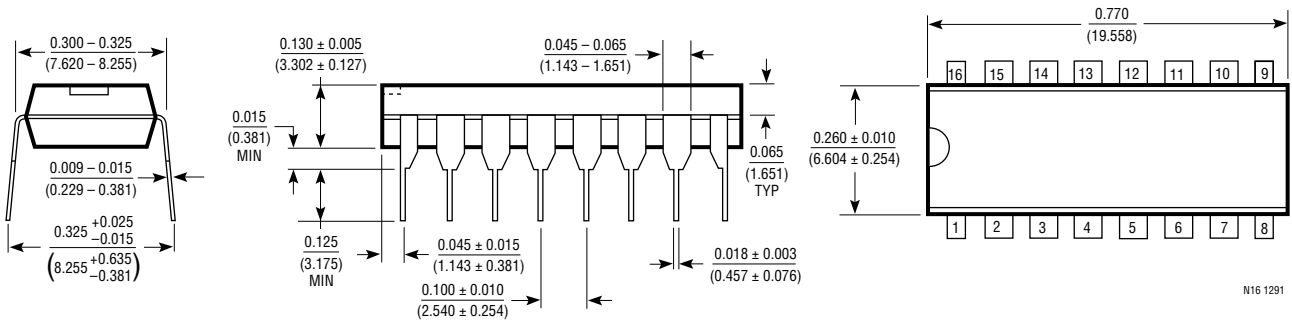

N16 1291

**S Package
16-Lead Plastic SOL**

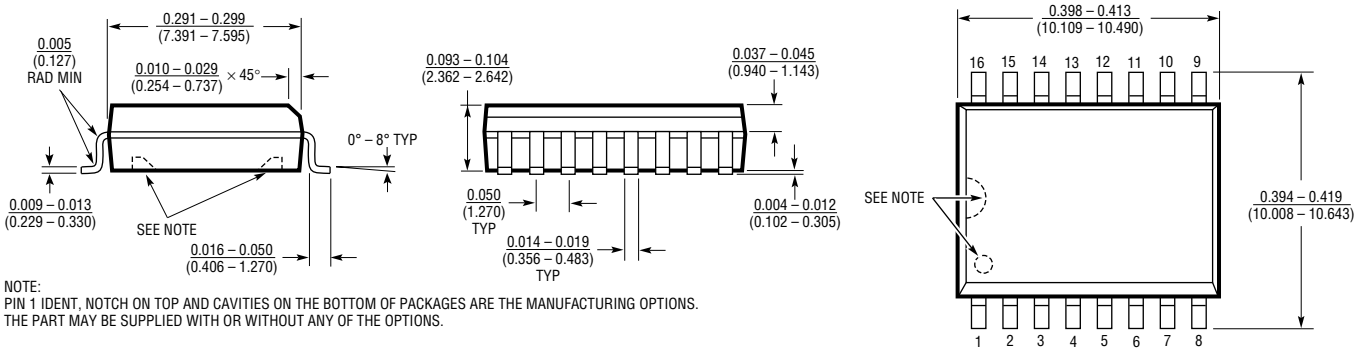

SOL16 12/91

Компания «Океан Электроники» предлагает заключение долгосрочных отношений при поставках импортных электронных компонентов на взаимовыгодных условиях!

Наши преимущества:

- Поставка оригинальных импортных электронных компонентов напрямую с производств Америки, Европы и Азии, а так же с крупнейших складов мира;
- Широкая линейка поставок активных и пассивных импортных электронных компонентов (более 30 млн. наименований);
- Поставка сложных, дефицитных, либо снятых с производства позиций;
- Оперативные сроки поставки под заказ (от 5 рабочих дней);
- Экспресс доставка в любую точку России;
- Помощь Конструкторского Отдела и консультации квалифицированных инженеров;
- Техническая поддержка проекта, помощь в подборе аналогов, поставка прототипов;
- Поставка электронных компонентов под контролем ВП;
- Система менеджмента качества сертифицирована по Международному стандарту ISO 9001;
- При необходимости вся продукция военного и аэрокосмического назначения проходит испытания и сертификацию в лаборатории (по согласованию с заказчиком);
- Поставка специализированных компонентов военного и аэрокосмического уровня качества (Xilinx, Altera, Analog Devices, Intersil, Interpoint, Microsemi, Actel, Aeroflex, Peregrine, VPT, Syfer, Eurofarad, Texas Instruments, MS Kennedy, Miteq, Cobham, E2V, MA-COM, Hittite, Mini-Circuits, General Dynamics и др.);

Компания «Океан Электроники» является официальным дистрибьютором и эксклюзивным представителем в России одного из крупнейших производителей разъемов военного и аэрокосмического назначения «JONHON», а так же официальным дистрибьютором и эксклюзивным представителем в России производителя высокотехнологичных и надежных решений для передачи СВЧ сигналов «FORSTAR».



JONHON

«JONHON» (основан в 1970 г.)

Разъемы специального, военного и аэрокосмического назначения:

(Применяются в военной, авиационной, аэрокосмической, морской, железнодорожной, горно- и нефтедобывающей отраслях промышленности)

«FORSTAR» (основан в 1998 г.)

ВЧ соединители, коаксиальные кабели,
кабельные сборки и микроволновые компоненты:

(Применяются в телекоммуникациях гражданского и специального назначения, в средствах связи, РЛС, а так же военной, авиационной и аэрокосмической отраслях промышленности).



Телефон: 8 (812) 309-75-97 (многоканальный)

Факс: 8 (812) 320-03-32

Электронная почта: ocean@oceanchips.ru

Web: <http://oceanchips.ru/>

Адрес: 198099, г. Санкт-Петербург, ул. Калинина, д. 2, корп. 4, лит. А