

### 8 PIN DIP HIGH SPEED 10MBit/s LOGIC GATE PHOTOCOUPLER 6N137 EL26XX series

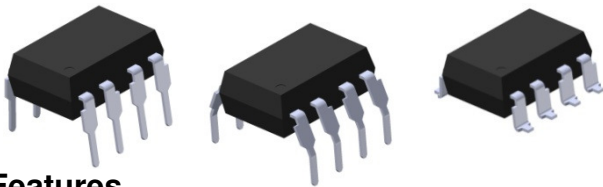

#### Features

- High speed 10Mbit/s
- 10kV/μs min. common mode transient immunity (EL2611)
- Guaranteed performance from -40 to 85°C
- Logic gate output
- High isolation voltage between input and output (Viso=5000 V rms )
- Pb free and RoHS compliant.
- UL approved (No. 214129)
- VDE approved (No. 132249)
- SEMKO approved
- NEMKO approved
- DEMKO approved
- FIMKO approved
- CSA approved (No. 2037145)

Schematic

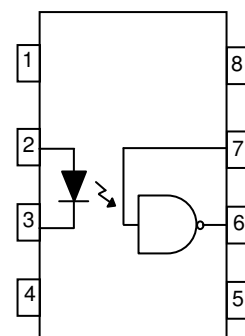

A 0.1μF bypass capacitor must be connected between pins 8 and 5<sup>\*3</sup>

#### Pin Configuration

- 1, No Connection
- 2, Anode
- 3, Cathode
- 4, No Connection
- 5, Gnd
- 6, Vout
- 7, V<sub>E</sub>
- 8, V<sub>CC</sub>

#### Description

The 6N137, EL2601 and EL2611 are consists of an infrared emitting diode optically coupled to a high speed integrated photo detector logic gate with a strobable output. It is packaged in a 8-pin DIP package and available in wide-lead spacing and SMD options.

#### Applications

- Ground loop elimination
- LSTTL to TTL, LSTTL or 5 volt CMOS
- Line receiver, data transmission
- Data multiplexing
- Switching power supplies
- Pulse transformer replacement
- Computer peripheral interface
- High speed logic ground isolation

#### Truth Table (Positive Logic)

Input	Enable	Output
H	H	L
L	H	H
H	L	H
L	L	H
H	NC	L
L	NC	H

**Absolute Maximum Ratings (Ta=25°C)**

	Parameter	Symbol	Rating	Unit
Input	Forward current	$I_F$	50	mA
	Enable input voltage Not exceed $V_{CC}$ by more than 500mV	$V_E$	5.5	V
	Reverse voltage	$V_R$	5	V
	Power dissipation	$P_D$	100	mW
Output	Power dissipation	$P_C$	85	mW
	Output current	$I_O$	50	mA
	Output voltage	$V_O$	7.0	V
	Supply voltage	$V_{CC}$	7.0	V
	Output Power Dissipation	$P_O$	100	mW
	Isolation voltage <sup>*1</sup>	$V_{ISO}$	5000	V rms
	Operating temperature	$T_{OPR}$	-40 ~ +85	°C
	Storage temperature	$T_{STG}$	-55 ~ +125	°C
	Soldering temperature <sup>*2</sup>	$T_{SOL}$	260	°C

Notes:

\*1 AC for 1 minute, R.H.= 40 ~ 60% R.H. In this test, pins 1, 2, 3 & 4 are shorted together, and pins 5, 6, 7 & 8 are shorted together.

\*2 For 10 seconds.

**Electrical Characteristics (Ta=-40 to 85 °C unless specified otherwise)**

**Input**

Parameter	Symbol	Min.	Typ.	Max.	Unit	Condition
Forward voltage	$V_F$	-	1.4	1.8	V	$I_F = 10\text{mA}$
Reverse voltage	$V_R$	5.0	-	-	V	$I_R = 10\mu\text{A}$
Temperature coefficient of forward voltage	$\Delta V_F/\Delta T_A$	-	-1.8	-	mV/°C	$I_F = 10\text{mA}$
Input capacitance	$C_{IN}$	-	60	-	pF	$V_F=0, f=1\text{MHz}$

**Output**

Parameter	Symbol	Min	Typ.	Max.	Unit	Condition
High level supply current	$I_{CCH}$	-	7	10	mA	$I_F=0\text{mA}, V_E=0.5\text{V}, V_{CC}=5.5\text{V}$
Low level supply current	$I_{CCL}$	-	9	13	mA	$I_F=10\text{mA}, V_{CC}=5.5\text{V}$
High level enable current	$I_{EH}$	-	- 0.6	-1.6	mA	$V_E=2.0\text{V}, V_{CC}=5.5\text{V}$
Low level enable current	$I_{EL}$	-	- 0.8	-1.6	mA	$V_E=0.5\text{V}, V_{CC}=5.5\text{V}$
High level enable voltage	$V_{EH}$	2.0	-	-	V	$I_F=10\text{mA}, V_{CC}=5.5\text{V}$
Low level enable voltage <sup>4</sup>	$V_{EL}$	-	-	0.8	V	$I_F=10\text{mA}, V_{CC}=5.5\text{V}$

**Transfer Characteristics (Ta=-40 to 85 °C unless specified otherwise)**

Parameter	Symbol	Min	Typ.	Max.	Unit	Condition
HIGH Level Output Current	$I_{OH}$	-	2.1	100	$\mu\text{A}$	$V_{CC}=5.5\text{V}, V_O=5.5\text{V}, I_F=250\mu\text{A}, V_E=2.0\text{V}$
LOW Level Output Current	$V_{OL}$	-	0.35	0.6	V	$V_{CC} = 5.5\text{V}, I_F=5\text{mA}, V_E=2.0\text{V}, I_{OL}=13\text{mA}$
Input Threshold Current	$I_{FT}$	-	2.5	5	mA	$V_{CC}= 5.5\text{V}, V_O=0.6\text{V}, V_E =2.0\text{V}, I_{OL}=13\text{mA}$

**Switching Characteristics ( $T_a=-40$  to  $85^\circ\text{C}$ ,  $V_{CC}=5\text{V}$ ,  $I_F=7.5\text{mA}$  unless specified otherwise)**

Parameter	Symbol	Min	Typ.	Max.	Unit	Condition
Propagation delay time to output High level* <sup>5</sup> (Fig.12)	$T_{PHL}$	-	35	75	ns	$C_L = 15\text{pF}$ , $R_L=350\Omega$ , $T_A=25^\circ\text{C}$
Propagation delay time to output Low level* <sup>6</sup> (Fig.12)	$T_{PLH}$	-	40	75	ns	$C_L = 15\text{pF}$ , $R_L=350\Omega$ , $T_A=25^\circ\text{C}$
Pulse width distortion	$ T_{phl} - T_{plh} $	-	5	35	ns	$C_L = 15\text{pF}$ , $R_L=350\Omega$
Output rise time* <sup>7</sup> (Fig.12)	$t_r$	-	40	-	ns	$C_L = 15\text{pF}$ , $R_L=350\Omega$
Output fall time* <sup>8</sup> (Fig.12)	$t_f$	-	10	-	ns	$C_L = 15\text{pF}$ , $R_L=350\Omega$

**Switching Characteristics ( $T_a=-40$  to  $85^\circ\text{C}$ ,  $V_{CC}=5\text{V}$ ,  $I_F=7.5\text{mA}$  unless specified otherwise)**

Parameter	Symbol	Min	Typ.	Max.	Unit	Condition
Enable Propagation Delay Time to Output High Level* <sup>9</sup> (Fig.13)	$t_{ELH}$	-	15	-	ns	$I_F = 7.5\text{mA}$ , $V_{EH}=3.5\text{V}$ , $C_L = 15\text{pF}$ , $R_L=350\Omega$
Enable Propagation Delay Time to Output Low Level* <sup>10</sup> (Fig.13)	$t_{EHL}$	-	15	-	ns	$I_F = 7.5\text{mA}$ , $V_{EH}=3.5\text{V}$ , $C_L = 15\text{pF}$ , $R_L=350\Omega$
Common Mode Transient Immunity at Logic High* <sup>11</sup>	6N137	-	-	-	V/ $\mu\text{S}$	$I_F = 7.5\text{mA}$ , $V_{OH}=2.0\text{V}$ , $R_L=350\Omega$ , $T_A=25^\circ\text{C}$ $V_{CM}=10\text{Vp-p}$ (Fig.14)
	EL2601	5,000	-	-		$I_F = 7.5\text{mA}$ , $V_{OH}=2.0\text{V}$ , $R_L=350\Omega$ , $T_A=25^\circ\text{C}$ $V_{CM}=50\text{Vp-p}$ (Fig.14)
	EL2611	10,000	-	-		$I_F = 7.5\text{mA}$ , $V_{OH}=2.0\text{V}$ , $R_L=350\Omega$ , $T_A=25^\circ\text{C}$ $V_{CM}=400\text{Vp-p}$ (Fig.14)
	EL2611	20,000	-	-		$I_F = 7.5\text{mA}$ , $V_{OH}=2.0\text{V}$ , $R_L=350\Omega$ , $T_A=25^\circ\text{C}$ $V_{CM}=400\text{Vp-p}$ (Fig.15)
Common Mode Transient Immunity at Logic Low* <sup>12</sup>	6N137	-	-	-	V/ $\mu\text{S}$	$I_F = 0\text{mA}$ , $V_{OL}=0.8\text{V}$ , $R_L=350\Omega$ , $T_A=25^\circ\text{C}$ $V_{CM}=10\text{Vp-p}$ (Fig.14)
	EL2601	5,000	-	-		$I_F = 0\text{mA}$ , $V_{OL}=0.8\text{V}$ , $R_L=350\Omega$ , $T_A=25^\circ\text{C}$ $V_{CM}=50\text{Vp-p}$ (Fig.14)
	EL2611	10,000	-	-		$I_F = 0\text{mA}$ , $V_{OL}=0.8\text{V}$ , $R_L=350\Omega$ , $T_A=25^\circ\text{C}$ $V_{CM}=400\text{Vp-p}$ (Fig.14)
	EL2611	20,000	-	-		$I_F = 7.5\text{mA}$ , $V_{OH}=2.0\text{V}$ , $R_L=350\Omega$ , $T_A=25^\circ\text{C}$ $V_{CM}=400\text{Vp-p}$ (Fig.15)

Typical Electro-Optical Characteristics Curves

Fig.1 Input Diode Forward Voltage vs. Forward Current

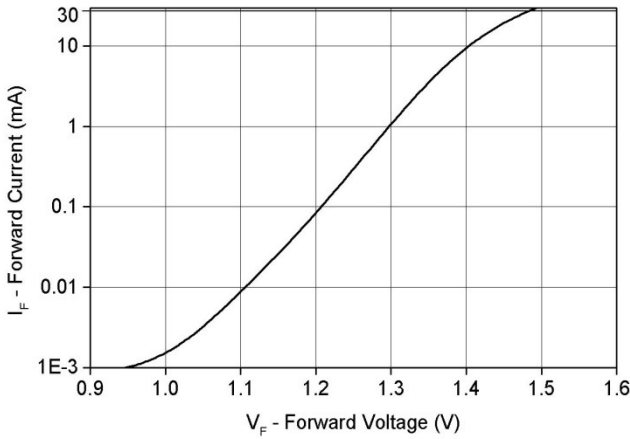

Fig.2 Low Level Output Voltage vs. Ambient Temperature

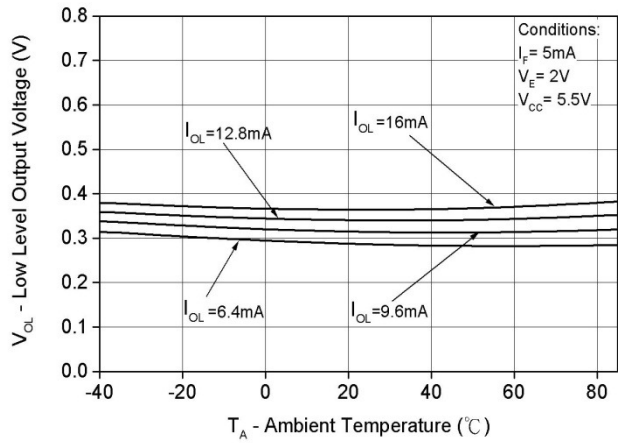

Fig.3 Low Level Output Current vs. Ambient Temperature

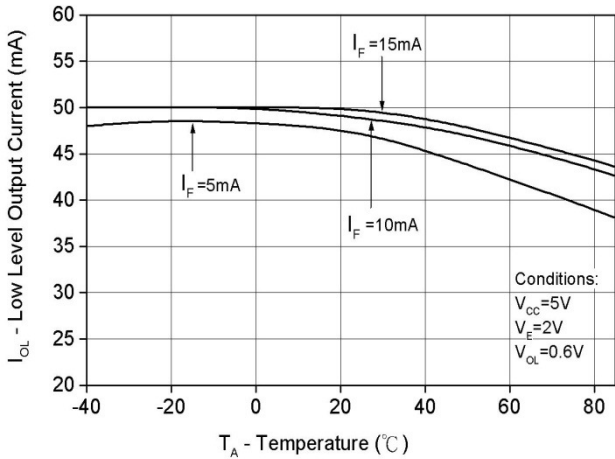

Fig.4 Input Threshold Current vs. Ambient Temperature

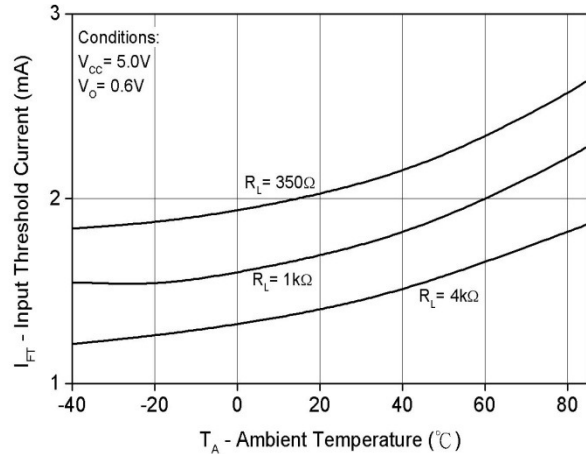

Fig.5 Output Voltage vs. Input Forward Current

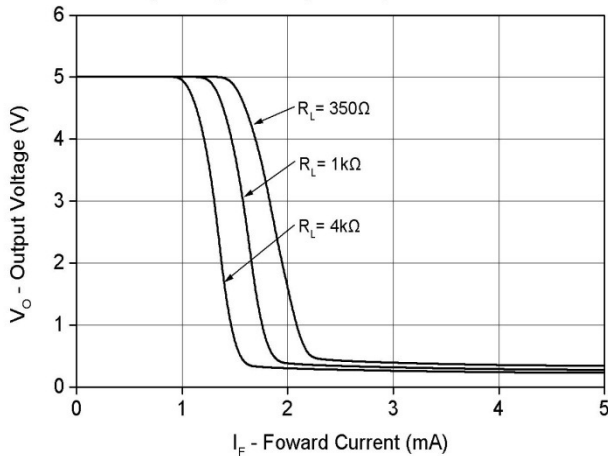
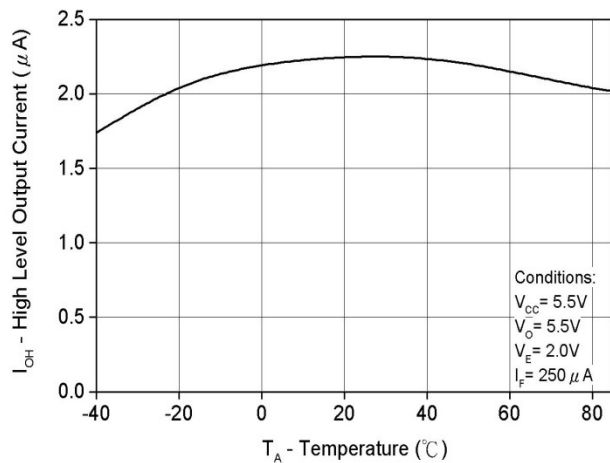

Fig.6 High Level Output Current vs. Temperature



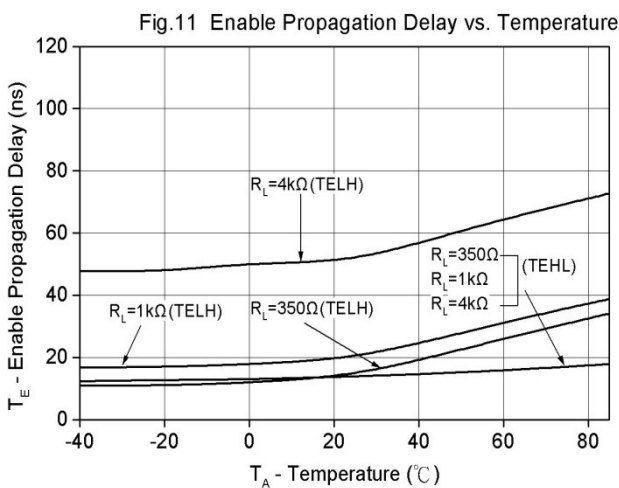
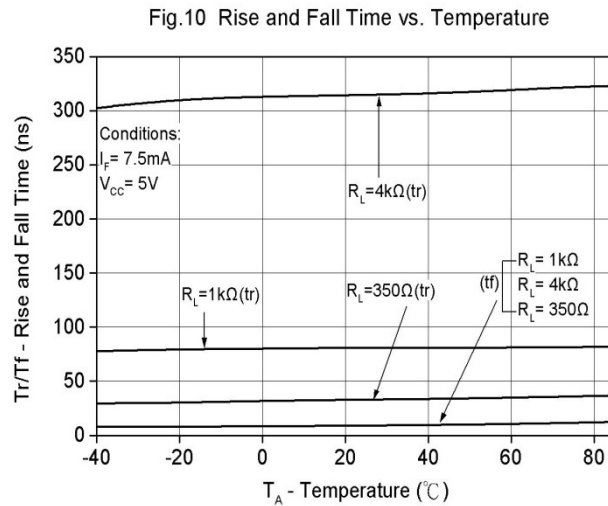
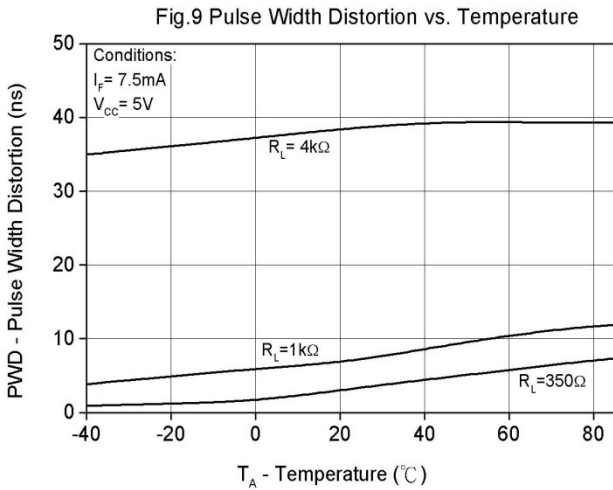
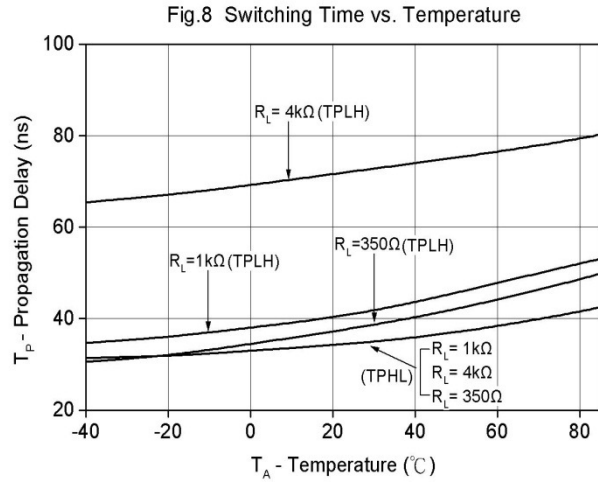
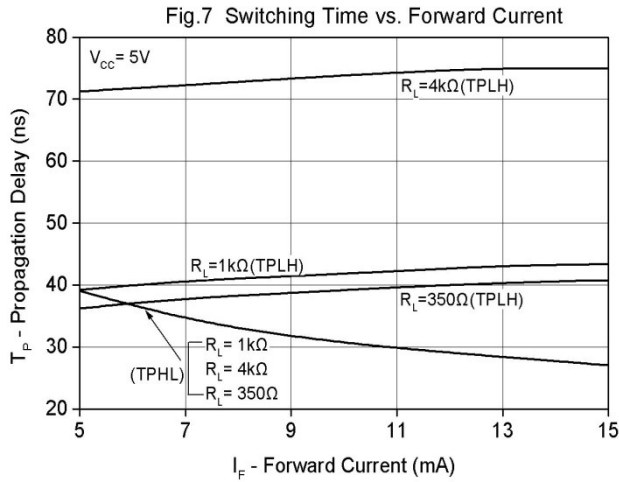

Fig. 12 Test circuit and waveforms for  $t_{PHL}$ ,  $t_{PLH}$ ,  $t_r$ , and  $t_f$

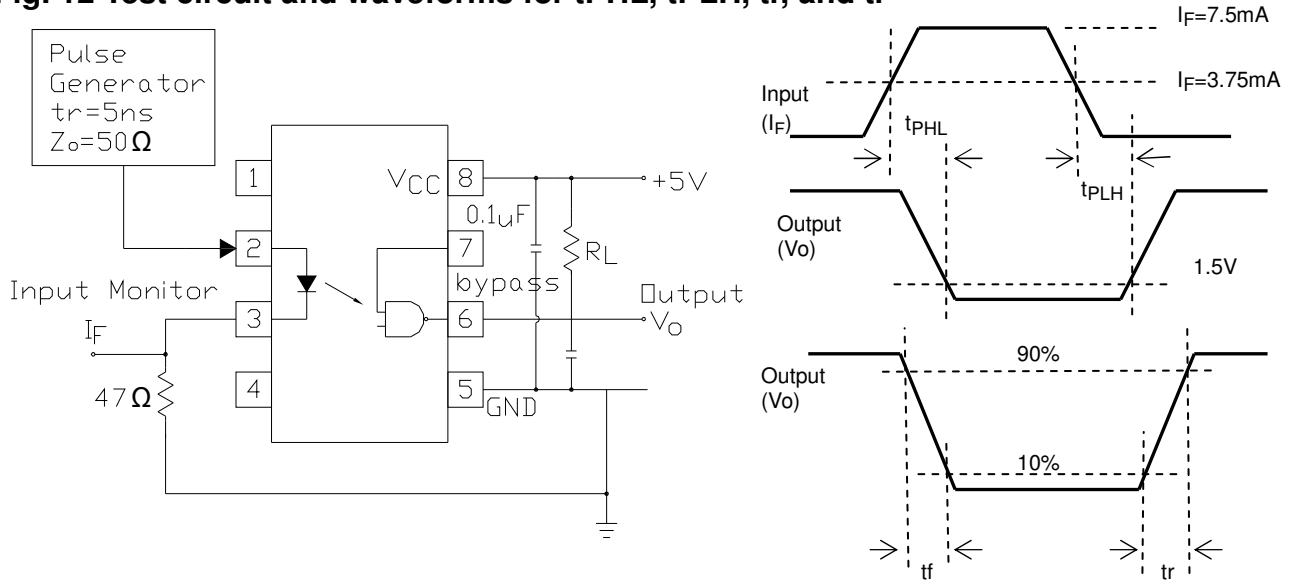

Fig. 13 Test circuit and waveform for  $t_{EHL}$  and  $t_{ELH}$

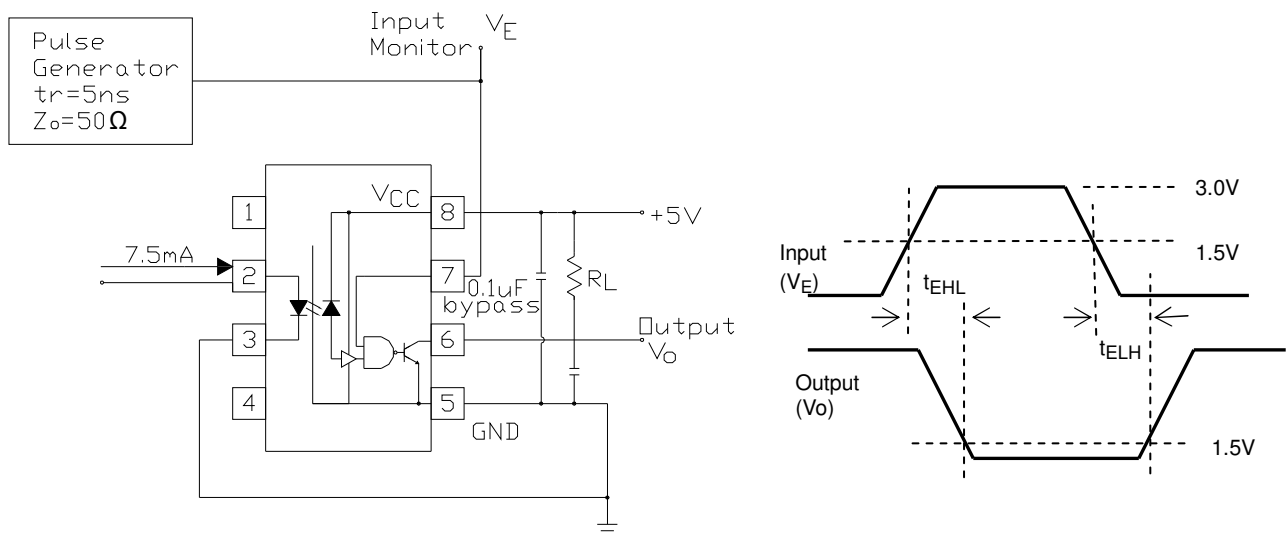

Fig. 14 Test circuit Common mode Transient Immunity

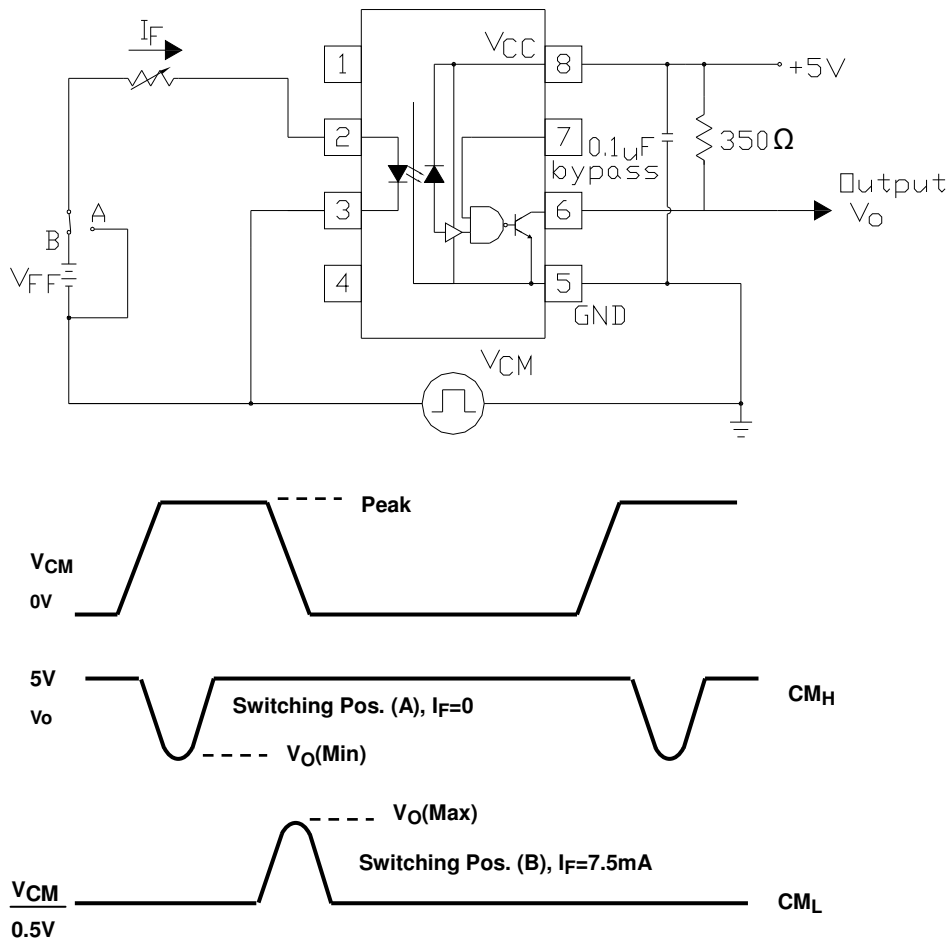
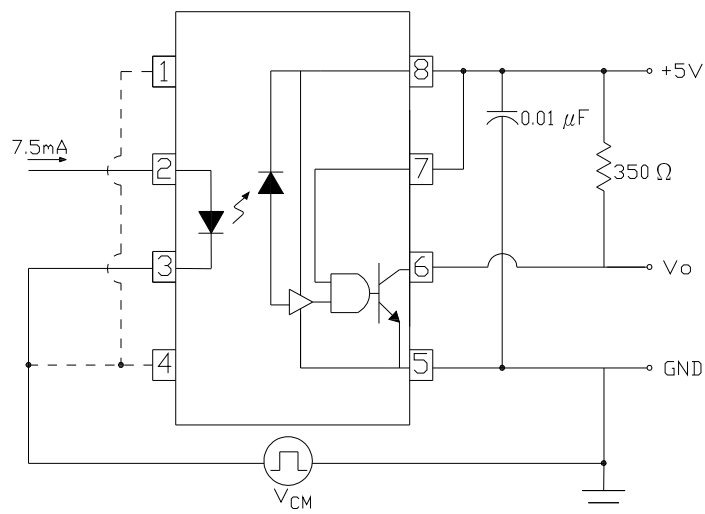

Fig. 15 Recommended drive circuit for EL2611 families for high-CMR





**Note**

- \*3 The VCC supply must be bypassed by a 0.1µF capacitor or larger. This can be either a ceramic or solid tantalum capacitor with good high frequency characteristic and should be connected as close as possible to the package VCC and GND pins
- \*4. Enable Input – No pull up resistor required as the device has an internal pull up resistor.
- \*5. tPLH – Propagation delay is measured from the 3.75mA level on the HIGH to LOW transition of the input current pulse to the 1.5 V level on the LOW to HIGH transition of the output voltage pulse.
- \*6. tPHL – Propagation delay is measured from the 3.75mA level on the LOW to HIGH transition of the input current pulse to the 1.5 V level on the HIGH to LOW transition of the output voltage pulse.
- \*7. tr – Rise time is measured from the 90% to the 10% levels on the LOW to HIGH transition of the output pulse.
- \*8. tf – Fall time is measured from the 10% to the 90% levels on the HIGH to LOW transition of the output pulse.
- \*9. tELH – Enable input propagation delay is measured from the 1.5V level on the HIGH to LOW transition of the input voltage pulse to the 1.5V level on the LOW to HIGH transition of the output voltage pulse.
- \*10. tEHL – Enable input propagation delay is measured from the 1.5V level on the LOW to HIGH transition of the input voltage pulse to the 1.5V level on the HIGH to LOW transition of the output voltage pulse.
- \*11 CMH– The maximum tolerable rate of rise of the common mode voltage to ensure the output will remain in the HIGH state (i.e., VOUT > 2.0V).
- \*12 CML– The maximum tolerable rate of rise of the common mode voltage to ensure the output will remain in the LOW output state (i.e., VOUT < 0.8V).

**Order Information**

**Part Number**

**6N137Y(Z)-V**

or

**EL26XXY(Z)-V**

**Note**

- X = (01 or 11) for EL26 part no.
- Y = Lead form option (S, S1, M or none)
- Z = Tape and reel option (TA, TB or none).
- V = VDE (optional)

Option	Description	Packing quantity
None	Standard DIP-8	45 units per tube
M	Wide lead bend (0.4 inch spacing)	45 units per tube
S (TA)	Surface mount lead form + TA tape & reel option	1000 units per reel
S (TB)	Surface mount lead form + TB tape & reel option	1000 units per reel
S1 (TA)	Surface mount lead form (low profile) + TA tape & reel option	1000 units per reel
S1 (TB)	Surface mount lead form (low profile) + TB tape & reel option	1000 units per reel

**Package Dimension**  
(Dimensions in mm)

**Standard DIP Type**

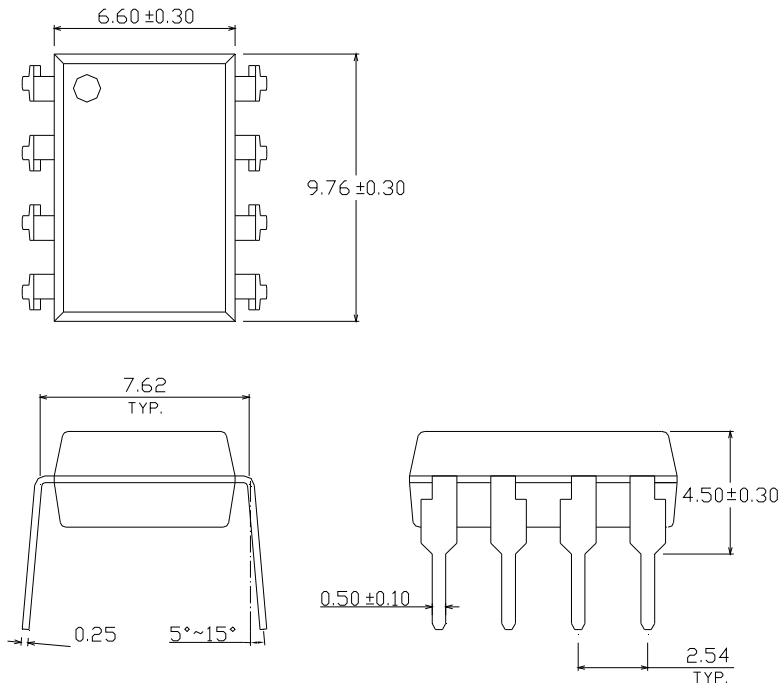

**Option M Type**

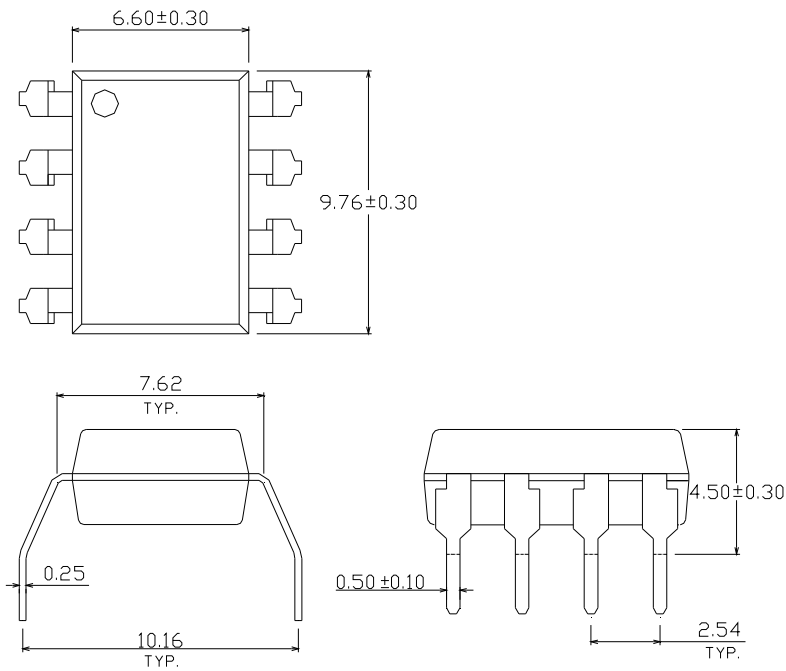

**Option S Type**

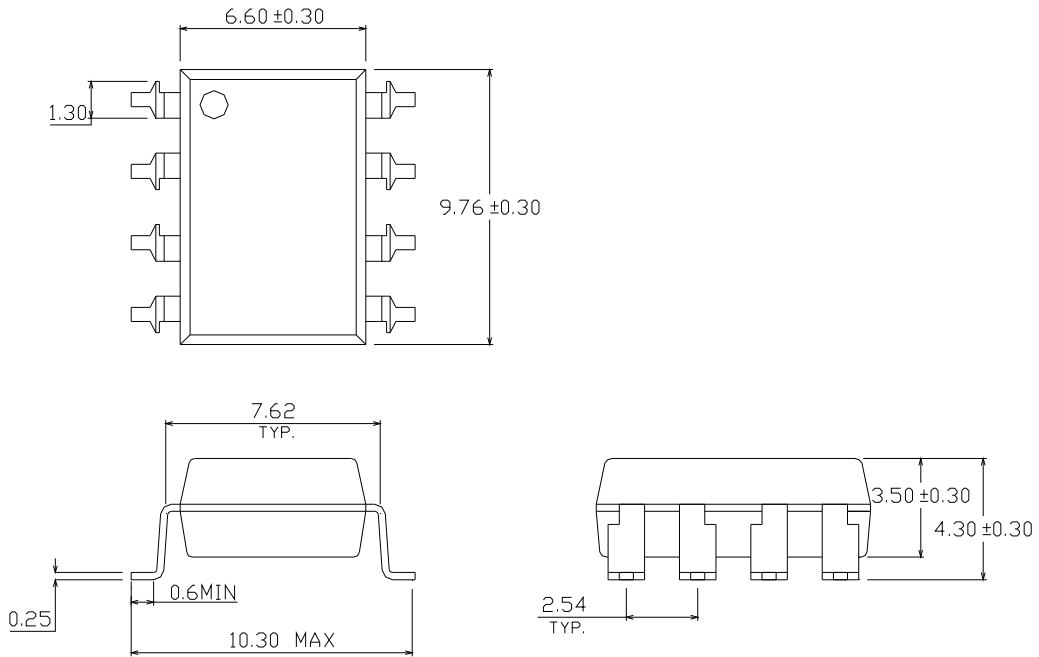

**Option S1 Type**

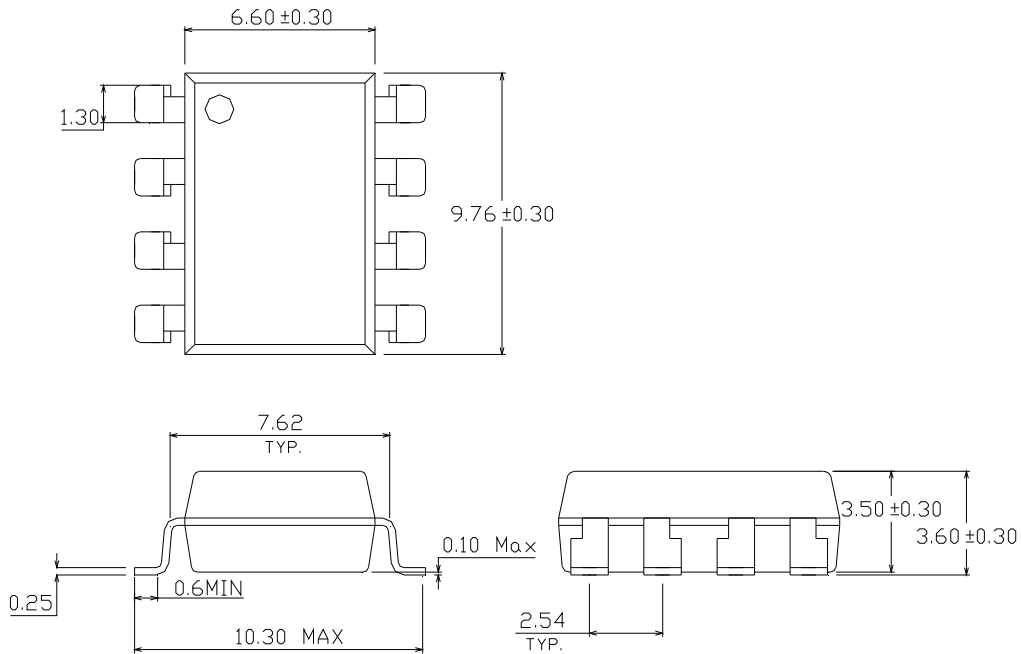

### Recommended pad layout for surface mount leadform

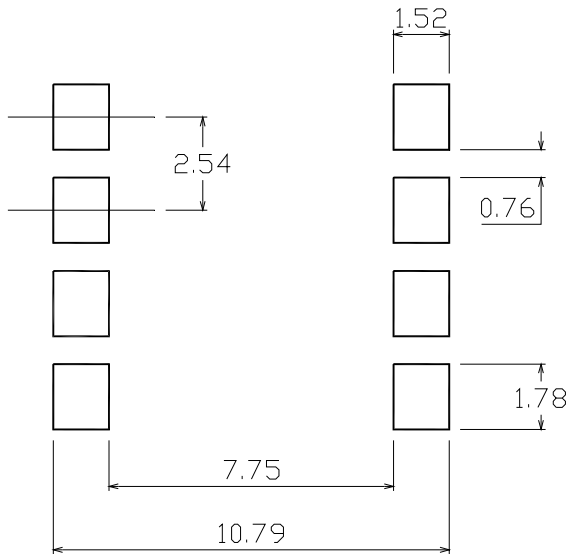

### Device Marking

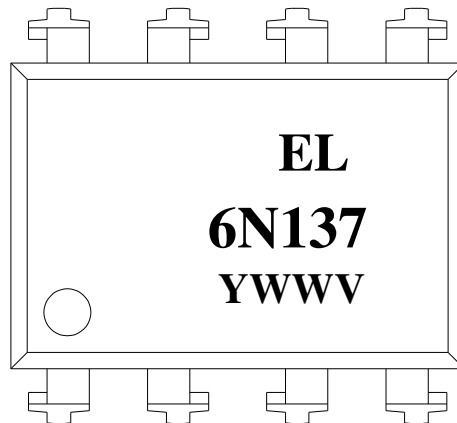

### Notes

- EL denotes EVERLIGHT
- 6N137 denotes Device Number
- Y denotes 1 digit Year code
- WW denotes 2 digit Week code
- V denotes VDE (optional)

**Tape & Reel Packing Specifications**

**Option TA**

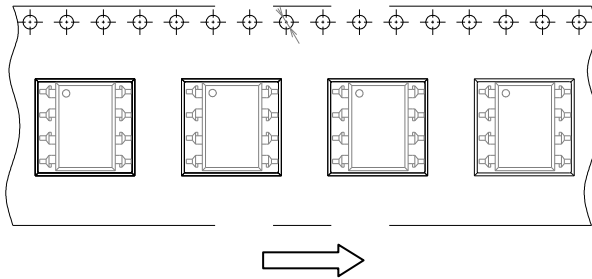

Direction of feed from reel

**Option TB**

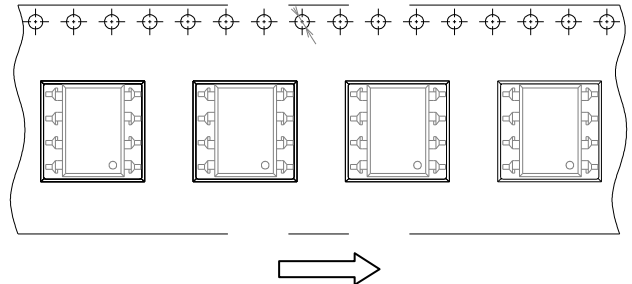

Direction of feed from reel

**Tape dimension**

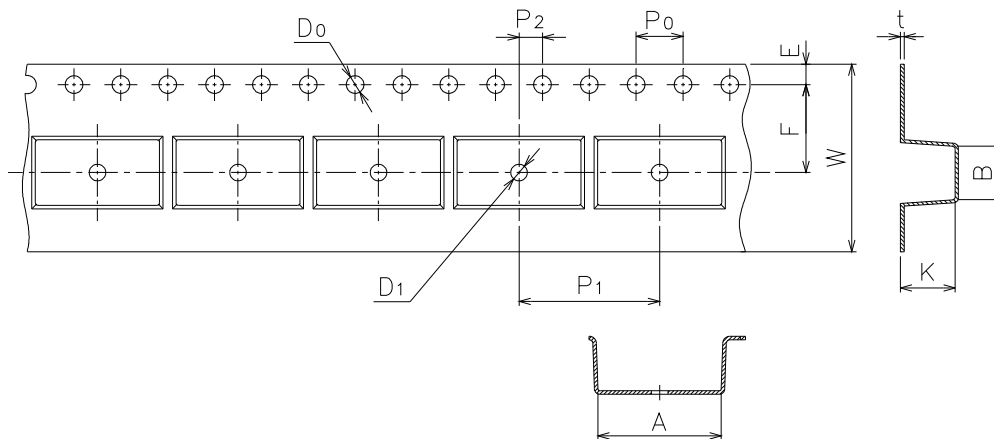

Dimension No.	<b>A</b>	<b>B</b>	<b>Do</b>	<b>D1</b>	<b>E</b>	<b>F</b>
Dimension(mm)	10.4±0.1	10.0±0.1	1.5+0.1/-0	1.5±0.25/-0	1.75±0.1	7.5±0.1
Dimension No.	<b>Po</b>	<b>P1</b>	<b>P2</b>	<b>t</b>	<b>W</b>	<b>K</b>
Dimension(mm)	4.0±0.1	12.0±0.1	2.0±0.05	0.4±0.05	16.0±0.3/	4.5±0.1

## Precautions for Use

### 1. Soldering Condition

#### 1.1 (A) Maximum Body Case Temperature Profile for evaluation of Reflow Profile

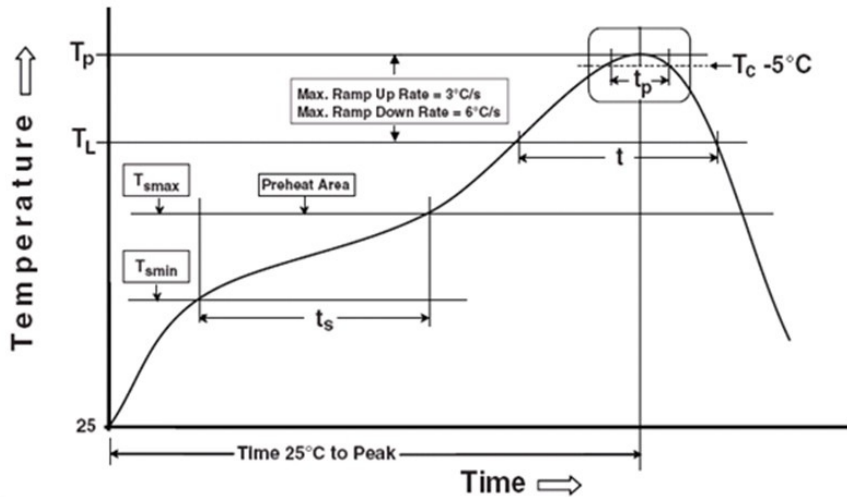

Note:

Reference: IPC/JEDEC J-STD-020D

#### Preheat

Temperature min ( $T_{smin}$ )	150 °C
Temperature max ( $T_{smax}$ )	200 °C
Time ( $T_{smin}$ to $T_{smax}$ ) ( $t_s$ )	60-120 seconds
Average ramp-up rate ( $T_{smax}$ to $T_p$ )	3 °C/second max

#### Other

Liquidus Temperature ( $T_L$ )	217 °C
Time above Liquidus Temperature ( $t_L$ )	60-100 sec
Peak Temperature ( $T_p$ )	260 °C
Time within 5 °C of Actual Peak Temperature: $T_p - 5 °C$	30 s
Ramp- Down Rate from Peak Temperature	6 °C /second max.
Time 25 °C to peak temperature	8 minutes max.
Reflow times	3 times

## **DISCLAIMER**

1. Above specification may be changed without notice. EVERLIGHT will reserve authority on material change for above specification.
2. When using this product, please observe the absolute maximum ratings and the instructions for using outlined in these specification sheets. EVERLIGHT assumes no responsibility for any damage resulting from use of the product which does not comply with the absolute maximum ratings and the instructions included in these specification sheets.
3. These specification sheets include materials protected under copyright of EVERLIGHT corporation. Please don't reproduce or cause anyone to reproduce them without EVERLIGHT's consent.

Компания «Океан Электроники» предлагает заключение долгосрочных отношений при поставках импортных электронных компонентов на взаимовыгодных условиях!

Наши преимущества:

- Поставка оригинальных импортных электронных компонентов напрямую с производств Америки, Европы и Азии, а так же с крупнейших складов мира;
- Широкая линейка поставок активных и пассивных импортных электронных компонентов (более 30 млн. наименований);
- Поставка сложных, дефицитных, либо снятых с производства позиций;
- Оперативные сроки поставки под заказ (от 5 рабочих дней);
- Экспресс доставка в любую точку России;
- Помощь Конструкторского Отдела и консультации квалифицированных инженеров;
- Техническая поддержка проекта, помощь в подборе аналогов, поставка прототипов;
- Поставка электронных компонентов под контролем ВП;
- Система менеджмента качества сертифицирована по Международному стандарту ISO 9001;
- При необходимости вся продукция военного и аэрокосмического назначения проходит испытания и сертификацию в лаборатории (по согласованию с заказчиком);
- Поставка специализированных компонентов военного и аэрокосмического уровня качества (Xilinx, Altera, Analog Devices, Intersil, Interpoint, Microsemi, Actel, Aeroflex, Peregrine, VPT, Syfer, Eurofarad, Texas Instruments, MS Kennedy, Miteq, Cobham, E2V, MA-COM, Hittite, Mini-Circuits, General Dynamics и др.);

Компания «Океан Электроники» является официальным дистрибьютором и эксклюзивным представителем в России одного из крупнейших производителей разъемов военного и аэрокосмического назначения «JONHON», а так же официальным дистрибьютором и эксклюзивным представителем в России производителя высокотехнологичных и надежных решений для передачи СВЧ сигналов «FORSTAR».



## JONHON

«JONHON» (основан в 1970 г.)

Разъемы специального, военного и аэрокосмического назначения:

(Применяются в военной, авиационной, аэрокосмической, морской, железнодорожной, горно- и нефтедобывающей отраслях промышленности)

«FORSTAR» (основан в 1998 г.)

ВЧ соединители, коаксиальные кабели, кабельные сборки и микроволновые компоненты:

(Применяются в телекоммуникациях гражданского и специального назначения, в средствах связи, РЛС, а так же военной, авиационной и аэрокосмической отраслях промышленности).



Телефон: 8 (812) 309-75-97 (многоканальный)

Факс: 8 (812) 320-03-32

Электронная почта: [ocean@oceanchips.ru](mailto:ocean@oceanchips.ru)

Web: <http://oceanchips.ru/>

Адрес: 198099, г. Санкт-Петербург, ул. Калинина, д. 2, корп. 4, лит. А