

## Automotive fully configurable 8-channel High/Low side MOSFET pre-driver suitable for 12 V and 24 V systems



TQFP64 exposed pad down

GADG160E171506PS

### Features



- AEC-Q100 qualified
- 12 V and 24 V battery systems compliance
- 3.3 V and 5 V logic compatible I/O
- 8-channel configurable MOSFET pre-driver
  - High-side (N-channel and P-channel MOS)
  - Low-side (N-channel MOS)
  - H-bridge (up to 2 H-bridge)
  - Peak & Hold (2 loads)
- Operating battery supply voltage 3.8 V to 36 V
- Operating VDD supply voltage 4.5 V to 5.5 V
- All device pins, except the ground pins, withstand at least 40 V
- Programmable gate charge/discharge currents for improving EMI behavior
- Individual diagnosis for:
  - Short circuit to battery
  - Open load
  - Short circuit to ground
- Highly flexible overcurrent sensing implementation
  - Possibility of monitoring external MOS drain to source voltage
  - Possibility of monitoring voltage on external shunt resistor
  - 64 programmable overcurrent thresholds independent for each channel
  - Ultra-fast output shutdown in case of overcurrent
- Current limitation for H-Bridge configuration
- 32-bit SPI protocol available for configuration and diagnostics
  - Failures latched even if they occur during diagnostics reading
  - Daisy chain operation
  - SDO protected against overvoltage
- Safety features
  - Fast switch off redundant output disable through two external pins
  - Built In Self Test (BIST) for logic operation
  - Hardware Self Check (HWSC) for VDD5 overvoltage comparator
  - Configurable Communication Check (CC) watchdog timer available
  - Disable feedback through bi-directional pin
  - Highly redundant output monitoring through dedicated SPI registers
- 10-bit ADC for battery and die temperature measurements available through SPI
- VDD5 monitoring for over/under voltage
- VPS (battery) monitoring for under voltage

#### Product status link

[L9945](#)

#### Product summary

Order code	Package	Packing
L9945	TQFP64	Tray
L9945TR	(exposed pad down)	Tape and reel

## Description

The L9945 is an 8-channel MOSFET pre-driver configurable for low-side, high-side, peak and hold and H-Bridge load control. It is designed to comply with the requirements of 12 V (passenger vehicle) and 24 V (commercial vehicle) battery systems.

All outputs can be PWM controlled. Six outputs are capable of driving safety relevant loads. One output can be dedicated to the actuation of safety relevant loads requiring a dedicated enable pin (EN6).

The device offers the possibility of controlling two independent H-Bridges.

The device can also drive up to two loads requiring "peak & hold" control strategy.

The driver outputs are protected against short circuit condition.

The device protects the external MOS in case of an overcurrent event.

Each output provides full diagnostic information such as short to battery, short to ground and open-load. Each output status can be constantly monitored through dedicated SPI registers.

The voltage slew rate of the external transistors 1-8 is controlled during turn ON and turn OFF in order to improve EMI behavior.

A double, redundant, external disable source is available through DIS and NDIS pins in order to improve safety.

The device is configurable via SPI through a 32-bit protocol.

# 1 Block diagram

Figure 1. Block diagram

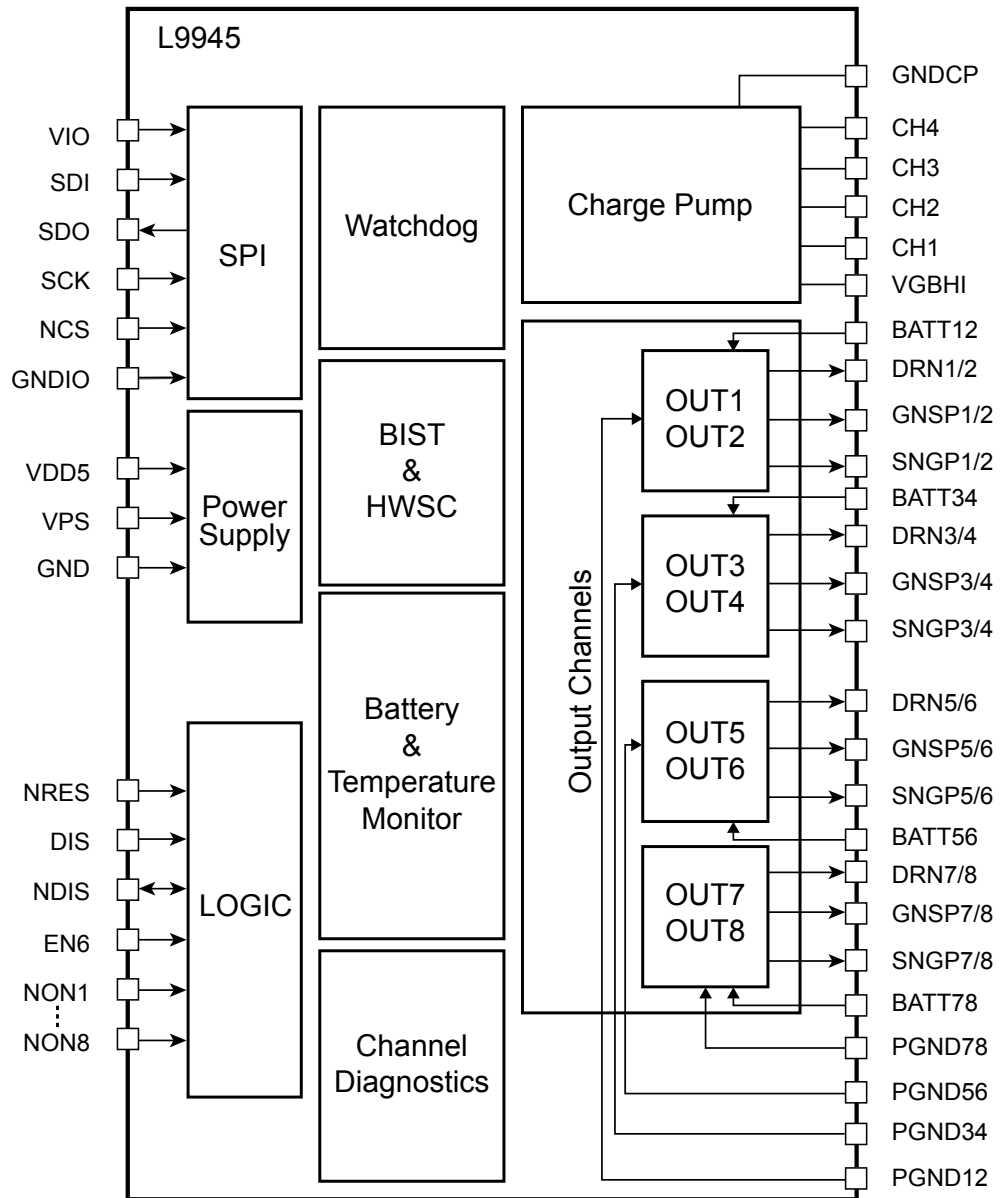

GADG2302170914PS

## 2 Pinout

The picture below shows the device pinout. Each pin features also the absolute maximum ratings. All pins, except the ground ones, can withstand at least 40 V to GND.

Maximum differential voltage allowed across the following pins is 20 V:

- GNSPx and SNGPx;
- CH2 and VPS;
- CH4 and CH2;
- VGBHI and VPS;
- VGBHI and CH4.

Figure 2. Pinout

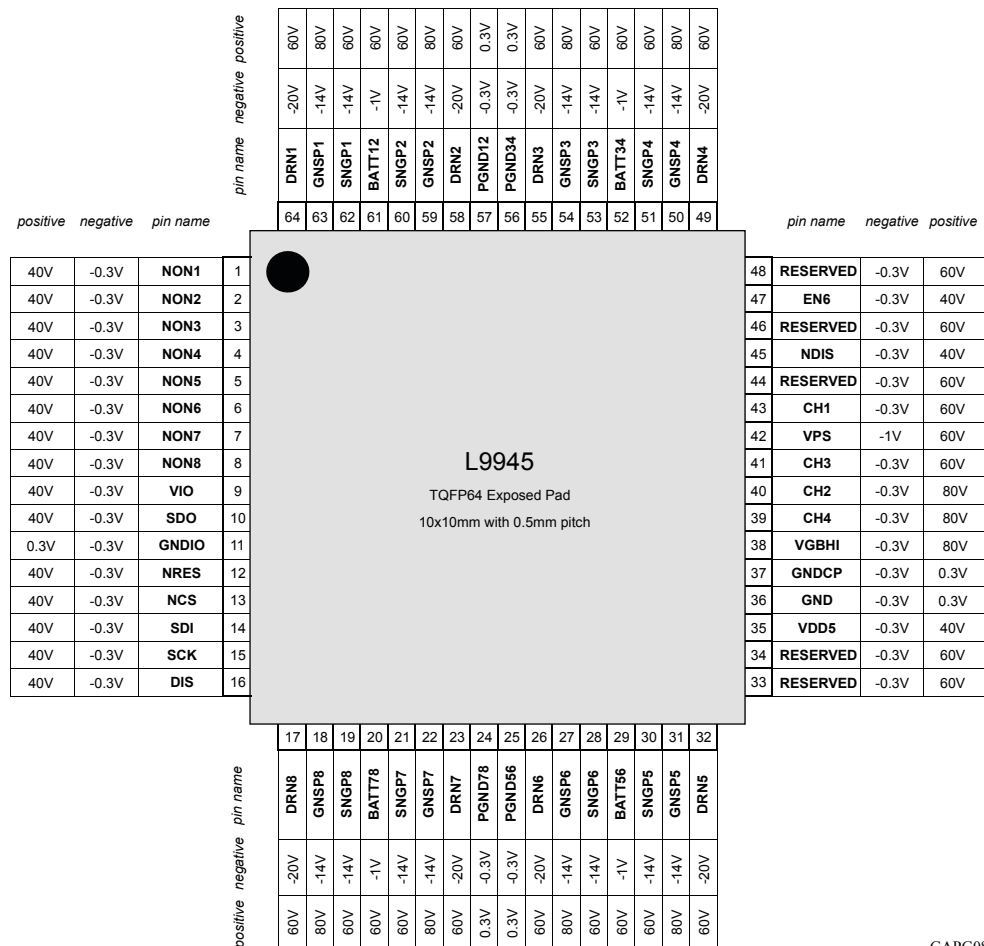

GAPG0802160930CFT

### 3 Package information

In order to meet environmental requirements, ST offers these devices in different grades of **ECOPACK®** packages, depending on their level of environmental compliance. ECOPACK® specifications, grade definitions and product status are available at: [www.st.com](http://www.st.com). ECOPACK® is an ST trademark.

#### 3.1 TQFP64 (10x10x1 mm exp. pad down) package information

**Figure 3. TQFP64 (10x10x1 mm exp. pad down) package outline**

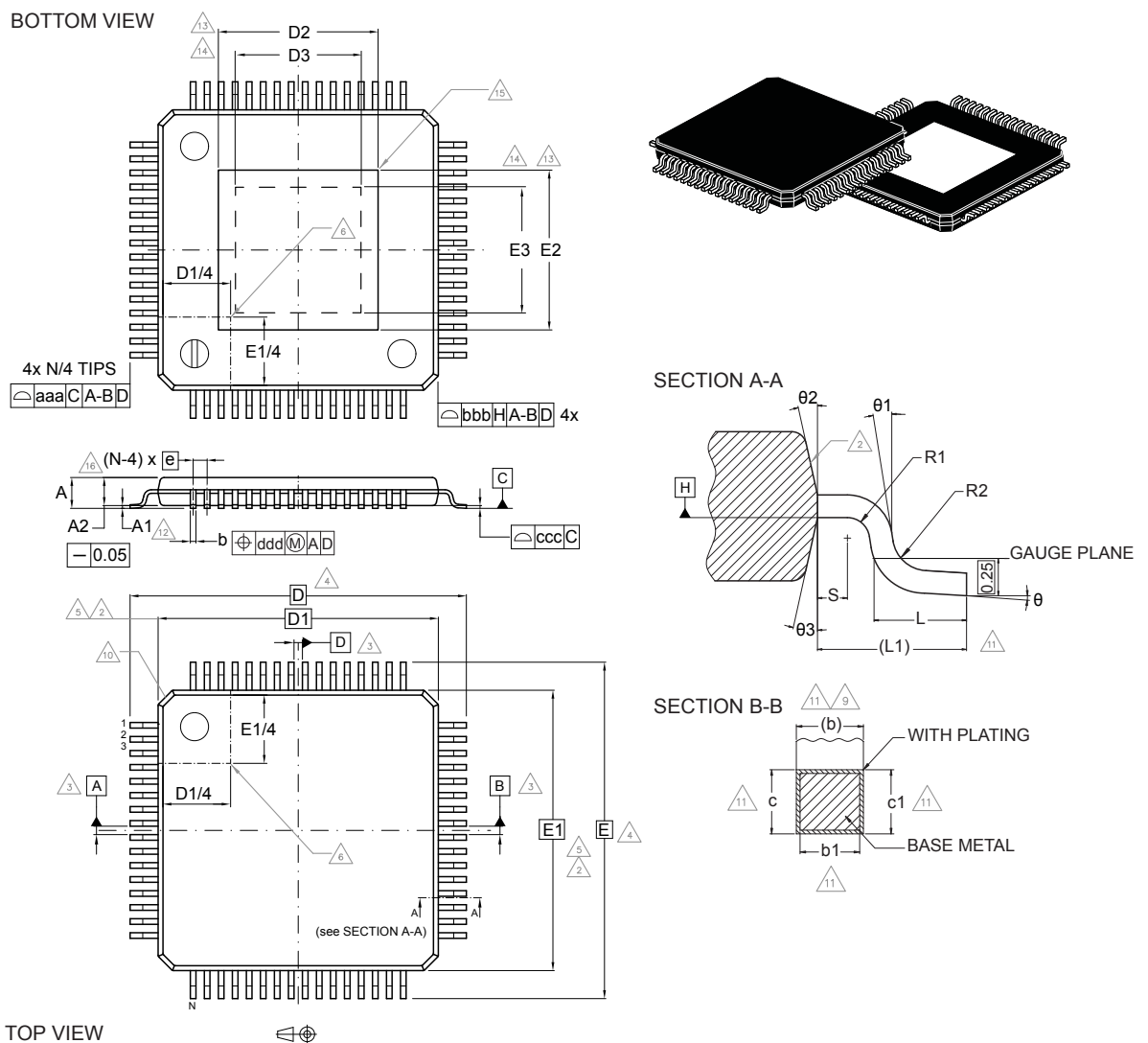

GAPGPS03451

**Table 1. TQFP64 (10x10x1 mm exp. pad down) package mechanical data**

Ref	Min.	Typ.	Max.	Note (see # in Notes below)
Θ	0°	3.5°	7°	-
Θ1	0°	-	-	-
Θ2	11°	12°	13°	-
Θ3	11°	12°	13°	-
A	-	-	1.2	15
A1	0.05	-	0.15	12
A2	0.95	1	1.05	15
b	0.17	0.22	0.27	9, 11
b1	0.17	0.2	0.23	11
c	0.09	-	0.2	11
c1	0.09	-	0.16	11
D	-	12.00 BSC	-	4
D1	-	10.00 BSC	-	5, 2
D2	-	-	6.4	13
D3	4.8	-	-	14
e	-	0.50 BSC	-	-
E	-	12.00 BSC	-	4
E1(*)	-	10.00 BSC	-	5, 2
E2	-	-	6.4	13
E3	4.8	-	-	14
L	0.45	0.6	0.75	-
L1	-	1.00 REF	-	-
N	-	64	-	16
R1	0.08	-	-	-
R2	0.08	-	0.2	-
S	0.2	-	-	-
<b>Tolerance of form and position</b>				
aaa	-	0.2	-	1, 7
bbb	-	0.2	-	
ccc	-	0.08	-	
ddd	-	0.08	-	

**Notes**

1. Dimensioning and tolerancing schemes conform to ASME Y14.5M-1994.
2. The Top package body size may be smaller than the bottom package size up to 0.15 mm.
3. Datum A-B and D to be determined at datum plane H.
4. To be determined at seating datum plane C.
5. Dimensions D1 and E1 do not include mold flash or protrusions. Allowable mold flash or protrusions is "0.25 mm" per side. D1 and E1 are Maximum plastic body size dimensions including mold mismatch.

6. Details of pin 1 identifier are optional but must be located within the zone indicated.
7. All Dimensions are in millimeters.
8. No intrusion allowed inwards the leads.
9. Dimension "b" does not include dambar protrusion. Allowable dambar protrusion shall not cause the lead width to exceed the maximum "b" dimension by more than 0.08 mm. Dambar cannot be located on the lower radius or the foot. Minimum space between protrusion and an adjacent lead is 0.07 mm for 0.4 mm and 0.5 mm pitch packages.
10. Exact shape of each corner is optional.
11. These dimensions apply to the flat section of the lead between 0.10 mm and 0.25 mm from the lead tip.
12. A1 is defined as the distance from the seating plane to the lowest point on the package body.
13. Dimensions D2 and E2 show the maximum exposed metal area on the package surface where the exposed pad is located (if present). It includes all metal protrusions from exposed pad itself.
14. Dimensions D3 and E3 show the minimum solderable area, defined as the portion of exposed pad which is guaranteed to be free from resin flashes/bleeds, bordered by internal edge of inner groove.
15. The optional exposed pad is generally coincident with the top or bottom side of the package and not allowed to protrude beyond that surface.
16. "N" is the number of terminal positions for the specified body size.

## Revision history

**Table 2. Document revision history**

Date	Version	Changes
16-Nov-2018	1	Initial release.



## Contents

<b>1</b>	<b>Block diagram</b> .....	<b>3</b>
<b>2</b>	<b>Pinout</b> .....	<b>4</b>
<b>3</b>	<b>Package information</b> .....	<b>5</b>
<b>3.1</b>	<b>TQFP64 (10x10x1 mm exp. pad down) package information</b> .....	<b>5</b>
	<b>Revision history</b> .....	<b>8</b>

**IMPORTANT NOTICE – PLEASE READ CAREFULLY**

STMicroelectronics NV and its subsidiaries (“ST”) reserve the right to make changes, corrections, enhancements, modifications, and improvements to ST products and/or to this document at any time without notice. Purchasers should obtain the latest relevant information on ST products before placing orders. ST products are sold pursuant to ST’s terms and conditions of sale in place at the time of order acknowledgement.

Purchasers are solely responsible for the choice, selection, and use of ST products and ST assumes no liability for application assistance or the design of Purchasers’ products.

No license, express or implied, to any intellectual property right is granted by ST herein.

Resale of ST products with provisions different from the information set forth herein shall void any warranty granted by ST for such product.

ST and the ST logo are trademarks of ST. All other product or service names are the property of their respective owners.

Information in this document supersedes and replaces information previously supplied in any prior versions of this document.

© 2018 STMicroelectronics – All rights reserved

Компания «Океан Электроники» предлагает заключение долгосрочных отношений при поставках импортных электронных компонентов на взаимовыгодных условиях!

Наши преимущества:

- Поставка оригинальных импортных электронных компонентов напрямую с производств Америки, Европы и Азии, а так же с крупнейших складов мира;
- Широкая линейка поставок активных и пассивных импортных электронных компонентов (более 30 млн. наименований);
- Поставка сложных, дефицитных, либо снятых с производства позиций;
- Оперативные сроки поставки под заказ (от 5 рабочих дней);
- Экспресс доставка в любую точку России;
- Помощь Конструкторского Отдела и консультации квалифицированных инженеров;
- Техническая поддержка проекта, помощь в подборе аналогов, поставка прототипов;
- Поставка электронных компонентов под контролем ВП;
- Система менеджмента качества сертифицирована по Международному стандарту ISO 9001;
- При необходимости вся продукция военного и аэрокосмического назначения проходит испытания и сертификацию в лаборатории (по согласованию с заказчиком);
- Поставка специализированных компонентов военного и аэрокосмического уровня качества (Xilinx, Altera, Analog Devices, Intersil, Interpoint, Microsemi, Actel, Aeroflex, Peregrine, VPT, Syfer, Eurofarad, Texas Instruments, MS Kennedy, Miteq, Cobham, E2V, MA-COM, Hittite, Mini-Circuits, General Dynamics и др.);

Компания «Океан Электроники» является официальным дистрибьютором и эксклюзивным представителем в России одного из крупнейших производителей разъемов военного и аэрокосмического назначения «JONHON», а так же официальным дистрибьютором и эксклюзивным представителем в России производителя высокотехнологичных и надежных решений для передачи СВЧ сигналов «FORSTAR».



## JONHON

«JONHON» (основан в 1970 г.)

Разъемы специального, военного и аэрокосмического назначения:

(Применяются в военной, авиационной, аэрокосмической, морской, железнодорожной, горно- и нефтедобывающей отраслях промышленности)

«FORSTAR» (основан в 1998 г.)

ВЧ соединители, коаксиальные кабели, кабельные сборки и микроволновые компоненты:

(Применяются в телекоммуникациях гражданского и специального назначения, в средствах связи, РЛС, а так же военной, авиационной и аэрокосмической отраслях промышленности).



Телефон: 8 (812) 309-75-97 (многоканальный)

Факс: 8 (812) 320-03-32

Электронная почта: [ocean@oceanchips.ru](mailto:ocean@oceanchips.ru)

Web: <http://oceanchips.ru/>

Адрес: 198099, г. Санкт-Петербург, ул. Калинина, д. 2, корп. 4, лит. А