

# LC75806PTS-T

## 1/4, 1/3-Duty LCD Driver with Key Input Function



**ON Semiconductor®**

www.onsemi.com

### Overview

The LC75806PTS-T is 1/4 duty and 1/3 duty LCD display driver that can directly drive up to 304 segments and can control up to 9 general-purpose output ports. This product also incorporates a key scan circuit that accepts input from up to 30 keys to reduce printed circuit board wiring.

### Features

- Key input function for up to 30 keys  
(A key scan is performed only when a key is pressed.)
- 1/4 duty 1/3 bias and 1/3 duty 1/3 bias drive schemes can be controlled from serial data.
- Capable of driving up to 304 segments using 1/4 duty and up to 231 segments using 1/3 duty.
- Switching between key scan output and segment output can be controlled from serial data.
- The key scan operation enabled/disabled state can be controlled from serial data.
- Switching between segment output port and general-purpose output port can be controlled from serial data.
- Switching between general-purpose output port, clock output port, and segment output port can be controlled from serial data.  
(Up to 9 general-purpose output ports and up to one clock output port)
- Serial data I/O supports CCB\* format communication with the system controller.  
(Support 3.3 V and 5 V operation)
- Sleep mode and all segments off functions that are controlled from serial data.
- The frame frequency of the common and segment output waveforms can be controlled from serial data.
- Switching between RC oscillator operating mode and external clock operating mode can be controlled from serial data.
- Direct display of display data without the use of a decoder provides high generality.
- Built-in display contrast adjustment circuit.
- Provision of an on-chip voltage-detection type reset circuit prevents incorrect displays.
- $\overline{\text{RES}}$  pin provided for forcibly initializing the IC internal circuits.

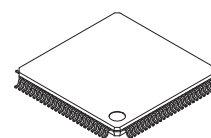

TQFP100 14x14 / TQFP100

\* Computer Control Bus (CCB) is an ON Semiconductor's original bus format and the bus addresses are controlled by ON Semiconductor.

### ORDERING INFORMATION

See detailed ordering and shipping information on page 36 of this data sheet.

# LC75806PTS-T

## Specifications

**Absolute Maximum Ratings** at Ta = 25°C, VSS = 0 V

| Parameter                   | Symbol  | Conditions   | Ratings         | Unit |
|-----------------------------|---------|--|-----------------|------|
| Maximum supply voltage      | VDD max | VDD  | -0.3 to +7.0    | V    |
| Input voltage               | VIN1    | CE, CL, DI, $\overline{\text{RES}}$                | -0.3 to +7.0    | V    |
|                             | VIN2    | OSC, TEST, VDD1, VDD2, KI1 to KI5                  | -0.3 to VDD+0.3 |      |
| Output voltage              | VOUT1   | DO   | -0.3 to +7.0    | V    |
|                             | VOUT2   | OSC, S1 to S77, COM1 to COM4, KS1 to KS6, P1 to P9 | -0.3 to VDD+0.3 |      |
| Output current              | IOUT1   | S1 to S77  | 300             | μA   |
|                             | IOUT2   | COM1 to COM4                                       | 3               |      |
|                             | IOUT3   | KS1 to KS6   | 1               |      |
|                             | IOUT4   | P1 to P9   | 5               |      |
| Allowable power dissipation | Pd max  | Ta = 105°C   | 100             | mW   |
| Operating temperature       | Topr    |  | -40 to +105     | °C   |
| Storage temperature         | Tstg    |  | -55 to +125     | °C   |

Stresses exceeding those listed in the Maximum Ratings table may damage the device. If any of these limits are exceeded, device functionality should not be assumed, damage may occur and reliability may be affected.

**Allowable Operating Ranges** at Ta = -40 to +105°C, VSS = 0 V

| Parameter   | Symbol          | Conditions  | Ratings |         |        | Unit |
|---|-----------------|---|---------|---------|--------|------|
|   |                 |   | min     | typ     | max    |      |
| Supply voltage                                    | VDD             | VDD   | 4.5     |         | 6.0    | V    |
| Input voltage *1                                  | VDD1            | VDD1  |         | 2/3VDD0 | VDD0   | V    |
|   | VDD2            | VDD2  |         | 1/3VDD0 | VDD0   |      |
| Input high level voltage                          | VIH1            | CE, CL, DI, $\overline{\text{RES}}$   | 0.4VDD  |         | 6.0    | V    |
|   | VIH2            | KI1 to KI5  | 0.6VDD  |         | VDD    |      |
|   | VIH3            | OSC: External clock operating mode  | 0.4VDD  |         | VDD    |      |
| Input low level voltage                           | VIL1            | CE, CL, DI, $\overline{\text{RES}}$   | 0       |         | 0.2VDD | V    |
|   | VIL2            | KI1 to KI5  | 0       |         | 0.2VDD |      |
|   | VIL3            | OSC: External clock operating mode  | 0       |         | 0.2VDD |      |
| Recommended external resistor for RC oscillation  | ROSC            | OSC: RC oscillation operating mode  |         | 39      |        | kΩ   |
| Recommended external capacitor for RC oscillation | COSC            | OSC: RC oscillation operating mode  |         | 1000    |        | pF   |
| Guaranteed range of RC oscillation                | fOSC            | OSC: RC oscillation operating mode  | 19      | 38      | 76     | kHz  |
| External clock operating frequency                | fCK             | OSC: External clock operating mode<br>[Figure4]                               | 10      | 38      | 76     | kHz  |
| External clock duty cycle                         | DCK             | OSC: External clock operating mode<br>[Figure4]                               | 30      | 50      | 70     | %    |
| Data setup time                                   | t <sub>ds</sub> | CL, DI [Figure2], [Figure3]   | 160     |         |        | ns   |
| Data hold time                                    | t <sub>dh</sub> | CL, DI [Figure2], [Figure3]   | 160     |         |        | ns   |
| CE wait time                                      | t <sub>cp</sub> | CE, CL [Figure2], [Figure3]   | 160     |         |        | ns   |
| CE setup time                                     | t <sub>cs</sub> | CE, CL [Figure2], [Figure3]   | 160     |         |        | ns   |
| CE hold time                                      | t <sub>ch</sub> | CE, CL [Figure2], [Figure3]   | 160     |         |        | ns   |
| High level clock pulse width                      | t <sub>φH</sub> | CL [Figure2], [Figure3]   | 160     |         |        | ns   |
| Low level clock pulse width                       | t <sub>φL</sub> | CL [Figure2], [Figure3]   | 160     |         |        | ns   |
| Rise time   | t <sub>r</sub>  | CE, CL, DI [Figure2], [Figure3]   |         | 160     |        | ns   |
| Fall time   | t <sub>f</sub>  | CE, CL, DI [Figure2], [Figure3]   |         | 160     |        | ns   |
| DO output delay time                              | t <sub>dc</sub> | DO R <sub>pU</sub> = 4.7 kΩ C <sub>L</sub> = 10 pF *2<br>[Figure2], [Figure3] |         |         | 1.5    | μs   |
| DO rise time                                      | t <sub>dr</sub> | DO R <sub>pU</sub> = 4.7 kΩ C <sub>L</sub> = 10 pF *2<br>[Figure2], [Figure3] |         |         | 1.5    | μs   |

Note: \*1. VDD0 = 0.70VDD to VDD

\*2. Since the DO pin is an open-drain output, these times depend on the values of the pull-up resistor R<sub>pU</sub> and the load capacitance C<sub>L</sub>.

Functional operation above the stresses listed in the Recommended Operating Ranges is not implied. Extended exposure to stresses beyond the Recommended Operating Ranges limits may affect device reliability.

# LC75806PTS-T

## Electrical Characteristics for the Allowable Operating Ranges

| Parameter                          | Symbol            | Pin                                 | Conditions  | Ratings                  |                      |                          | Unit |
|------------------------------------|-------------------|-------------------------------------|---|--------------------------|----------------------|--------------------------|------|
|                                    |                   |                                     |   | min                      | typ                  | max                      |      |
| Hysteresis                         | V <sub>H1</sub>   | CE, CL, DI, $\overline{\text{RES}}$ |   |                          | 0.03V <sub>DD</sub>  |                          | V    |
|                                    | V <sub>H2</sub>   | KI1 to KI5                          |   |                          | 0.1V <sub>DD</sub>   |                          |      |
| Power-down detection voltage       | V <sub>DET</sub>  |                                     |   | 2.0                      | 2.3                  | 2.6                      | V    |
| Input high level current           | I <sub>IH1</sub>  | CE, CL, DI, $\overline{\text{RES}}$ | V <sub>I</sub> = 6.0 V  |                          |                      | 5.0                      | μA   |
|                                    | I <sub>IH2</sub>  | OSC                                 | V <sub>I</sub> = V <sub>DD</sub> : External clock operating mode  |                          |                      | 5.0                      |      |
| Input low level current            | I <sub>IL1</sub>  | CE, CL, DI, $\overline{\text{RES}}$ | V <sub>I</sub> = 0 V  | -5.0                     |                      |                          | μA   |
|                                    | I <sub>IL2</sub>  | OSC                                 | V <sub>I</sub> = 0 V : External clock operating mode  | -5.0                     |                      |                          |      |
| Input floating voltage             | V <sub>IF</sub>   | KI1 to KI5                          |   |                          |                      | 0.05V <sub>DD</sub>      | V    |
| Pull-down resistance               | R <sub>PD</sub>   | KI1 to KI5                          | V <sub>DD</sub> = 5.0 V   | 50                       | 100                  | 250                      | kΩ   |
| Output off leakage current         | I <sub>OFFH</sub> | DO                                  | V <sub>O</sub> = 6.0 V  |                          |                      | 6.0                      | μA   |
| Output high level voltage *1       | V <sub>OH1</sub>  | KS1 to KS6                          | I <sub>O</sub> = -500 μA  | V <sub>DD</sub> -1.0     | V <sub>DD</sub> -0.5 | V <sub>DD</sub> -0.2     | V    |
|                                    | V <sub>OH2</sub>  | P1 to P9                            | I <sub>O</sub> = -1 mA  | V <sub>DD</sub> -0.9     |                      |                          |      |
|                                    | V <sub>OH3</sub>  | S1 to S77                           | I <sub>O</sub> = -20 μA   | V <sub>DD</sub> 0-0.9    |                      |                          |      |
|                                    | V <sub>OH4</sub>  | COM1 to COM4                        | I <sub>O</sub> = -100 μA  | V <sub>DD</sub> 0-0.9    |                      |                          |      |
| Output low level voltage           | V <sub>OL1</sub>  | KS1 to KS6                          | I <sub>O</sub> = 25 μA  | 0.2                      | 0.5                  | 1.5                      | V    |
|                                    | V <sub>OL2</sub>  | P1 to P9                            | I <sub>O</sub> = 1 mA   |                          |                      | 0.9                      |      |
|                                    | V <sub>OL3</sub>  | S1 to S77                           | I <sub>O</sub> = 20 μA  |                          |                      | 0.9                      |      |
|                                    | V <sub>OL4</sub>  | COM1 to COM4                        | I <sub>O</sub> = 100 μA   |                          |                      | 0.9                      |      |
|                                    | V <sub>OL5</sub>  | DO                                  | I <sub>O</sub> = 1 mA   |                          | 0.1                  | 0.3                      |      |
| Output middle level voltage *1, *3 | V <sub>MID1</sub> | S1 to S77                           | 1/3 bias I <sub>O</sub> = ±20 μA  | 2/3V <sub>DD</sub> 0-0.9 |                      | 2/3V <sub>DD</sub> 0+0.9 | V    |
|                                    | V <sub>MID2</sub> | S1 to S77                           | 1/3 bias I <sub>O</sub> = ±20 μA  | 1/3V <sub>DD</sub> 0-0.9 |                      | 1/3V <sub>DD</sub> 0+0.9 |      |
|                                    | V <sub>MID3</sub> | COM1 to COM4                        | 1/3 bias I <sub>O</sub> = ±100 μA   | 2/3V <sub>DD</sub> 0-0.9 |                      | 2/3V <sub>DD</sub> 0+0.9 |      |
|                                    | V <sub>MID4</sub> | COM1 to COM4                        | 1/3 bias I <sub>O</sub> = ±100 μA   | 1/3V <sub>DD</sub> 0-0.9 |                      | 1/3V <sub>DD</sub> 0+0.9 |      |
| Oscillator frequency               | f <sub>OSC</sub>  | OSC                                 | R <sub>OSC</sub> = 39 kΩ,<br>C <sub>OSC</sub> = 1000 pF<br>RC oscillation operating mode  | 30.4                     | 38                   | 45.6                     | kHz  |
| Current drain                      | I <sub>DD1</sub>  | V <sub>DD</sub>                     | Sleep mode  |                          |                      | 100                      | μA   |
|                                    | I <sub>DD2</sub>  | V <sub>DD</sub>                     | V <sub>DD</sub> = 6.0 V,<br>Output open,<br>RC oscillation operating mode,<br>f <sub>OSC</sub> = 38 kHz   |                          | 1300                 | 2600                     |      |
|                                    | I <sub>DD3</sub>  | V <sub>DD</sub>                     | V <sub>DD</sub> = 6.0 V,<br>Output open,<br>External clock operating mode,<br>f <sub>CK</sub> = 38 kHz,<br>V <sub>IH3</sub> = 0.5V <sub>DD</sub> ,<br>V <sub>IL3</sub> = 0.1V <sub>DD</sub> |                          | 1400                 | 2800                     |      |

Note: \*1. V<sub>DD</sub>0 = 0.70V<sub>DD</sub> to V<sub>DD</sub>

\*3. Excluding the bias voltage generation divider resistor built into the V<sub>DD</sub>0, V<sub>DD</sub>1, V<sub>DD</sub>2 and V<sub>SS</sub>.

(See [Figure 1])

Product parametric performance is indicated in the Electrical Characteristics for the listed test conditions, unless otherwise noted. Product performance may not be indicated by the Electrical Characteristics if operated under different conditions.

# LC75806PTS-T

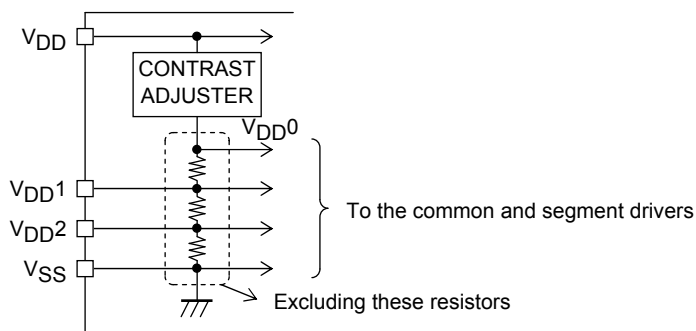

[Figure 1]

## 1. When CL is stopped at the low level

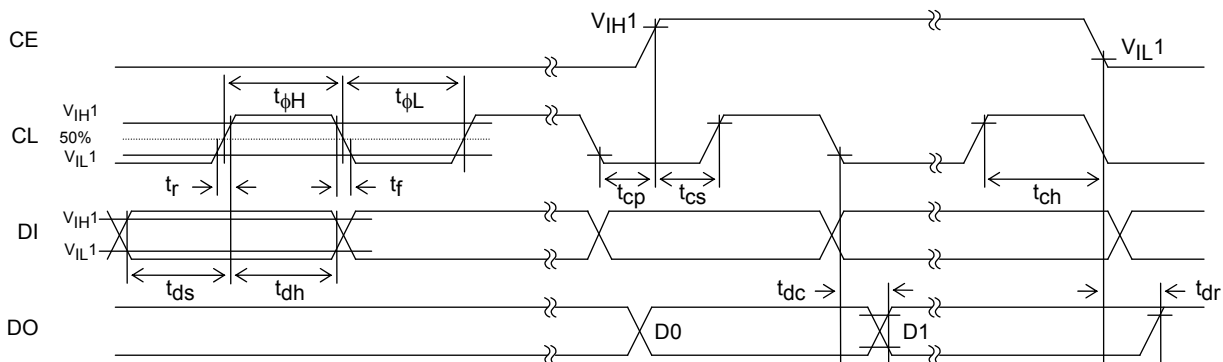

[Figure 2]

## 2. When CL is stopped at the high level

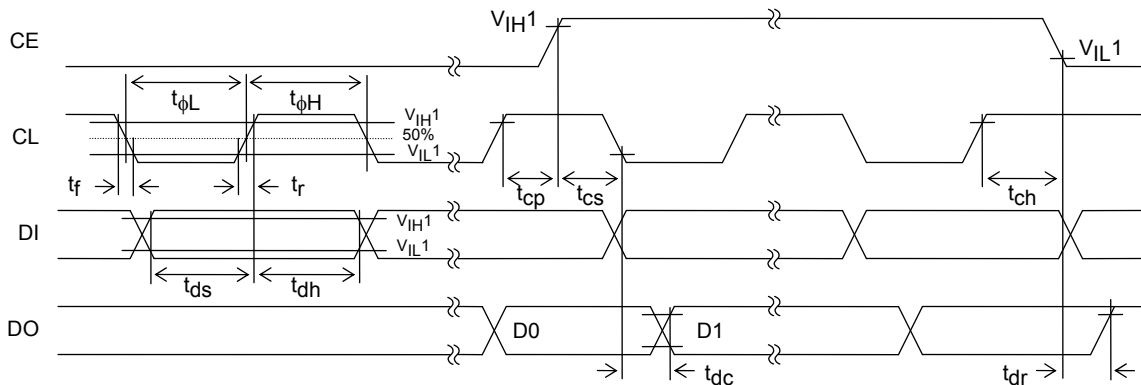

[Figure 3]

## 3. OSC pin clock timing in external clock operating mode

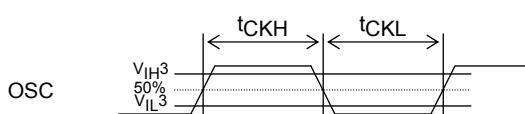

[Figure 4]

$$f_{CK} = \frac{1}{t_{CKH} + t_{CKL}} \quad [\text{kHz}]$$

$$D_{CK} = \frac{t_{CKH}}{t_{CKH} + t_{CKL}} \times 100[\%]$$

# LC75806PTS-T

## Pin Assignment

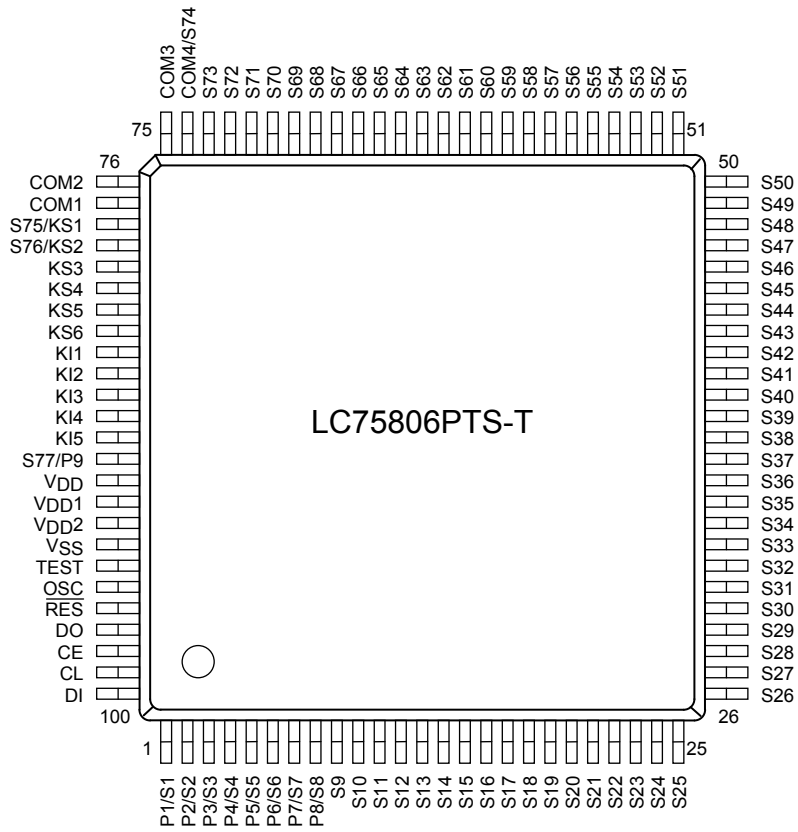

Top view

# LC75806PTS-T

## Block Diagram

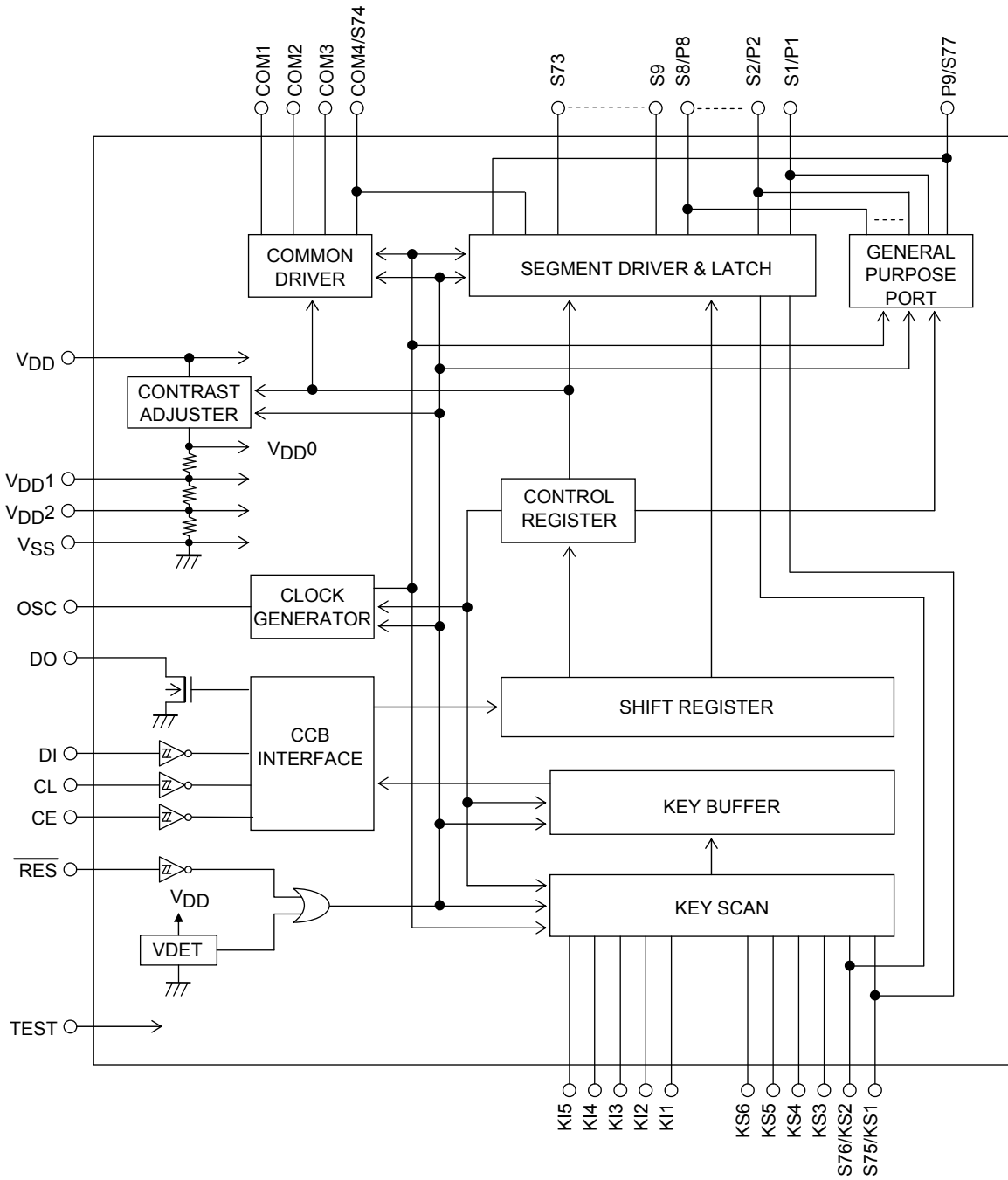

# LC75806PTS-T

## Pin Functions

| Symbol                           | Pin No.              | Function  | Active  | I/O | Handling when unused |
|----------------------------------|----------------------|---|---|-----|----------------------|
| S1/P1 to S8/P8<br>S9 to S73      | 1 to 8<br>9 to 73    | Segment outputs for displaying the display data transferred by serial data input. The S1/P1 to S8/P8 pins can be used as general-purpose output ports under serial data control.  | -   | O   | OPEN                 |
| COM1 to COM3<br>COM4/S74         | 77 to 75<br>74       | Common driver outputs.<br>The frame frequency is $f_O$ [Hz].<br>The COM4/S74 pin can be used as a segment output in 1/3 duty.   | -   | O   | OPEN                 |
| KS1/S75<br>KS2/S76<br>KS3 to KS6 | 78<br>79<br>80 to 83 | Key scan outputs. Although normal key scan timing lines require diodes to be inserted in the timing lines to prevent shorts, since these outputs are unbalanced CMOS transistor outputs, these outputs will not be damaged by shorting when these outputs are used to form a key matrix. The KS1/S75 and KS2/S76 pins can be used as segment outputs when so specified by the control data.   | -   | O   | OPEN                 |
| KI1 to KI5                       | 84 to 88             | Key scan inputs.<br>These pins have built-in pull-down resistors.   | H   | I   | GND                  |
| P9/S77                           | 89                   | General-purpose output port.<br>This pin can be used as clock output port or segment output port under serial data control.   | -   | O   | OPEN                 |
| OSC                              | 95                   | Oscillator connections. An oscillator circuit is formed by connecting an external resistor and capacitor at this pin. This pin can also be used as the external clock input pin if the external clock operating mode is selected with the control data.   | -   | I/O | V <sub>DD</sub>      |
| CE                               | 98                   | Serial data interface connections to the controller. Note that DO, being an open-drain output, requires a pull-up resistor.<br>CE: Chip enable<br>CL: Synchronization clock<br>DI: Transfer data<br>DO: Output data   | H   | I   | GND                  |
| CL                               | 99                   |   |  | I   |                      |
| DI                               | 100                  |   | -   | I   |                      |
| DO                               | 97                   |   | -   | O   | OPEN                 |
| $\overline{\text{RES}}$          | 96                   | Reset signal input<br><ul style="list-style-type: none"> <li>• <math>\overline{\text{RES}}</math>=Low ... Display off <ul style="list-style-type: none"> <li>- S1/P1 to S8/P8, KS1/S75, KS2/S76=Low<br/>(These pins are forcibly set to the segment output port function and fixed at the low level.)</li> <li>- S9 to S73=Low</li> <li>- COM1 to COM3=Low</li> <li>- COM4/S74=Low<br/>(This pin is forcibly set to the common output function and fixed at the low level.)</li> <li>- P9/S77=Low<br/>(This pin is forcibly set to the general-purpose output port function and fixed at the low level.)</li> <li>- KS3 to KS6=Low</li> <li>- Key scanning disabled</li> <li>- All the key data is reset to low.</li> <li>- OSC="Z"(High impedance)</li> <li>- RC oscillation stopped</li> <li>- Inhibits external clock input</li> <li>- Display contrast adjustment circuit stopped.</li> </ul> </li> <li>• <math>\overline{\text{RES}}</math>=High ... Display on <ul style="list-style-type: none"> <li>- General-purpose output port state setting is enabled</li> <li>- Key scanning is enabled.</li> <li>- RC oscillation enabled (RC oscillator operating mode)</li> <li>- Enables external clock input (external clock operating mode)</li> <li>- Display contrast adjustment circuit operation is enabled.</li> </ul> </li> </ul> <p>However, serial data can be transferred when the <math>\overline{\text{RES}}</math> pin is low</p> | L   | I   | V <sub>DD</sub>      |
| TEST                             | 94                   | This pin must be connected to ground.   | -   | I   | -                    |
| V <sub>DD1</sub>                 | 91                   | LCD drive 2/3 bias voltage (middle level) supply pin. This pin can be used to supply the 2/3 V <sub>DD0</sub> voltage level externally.   | -   | I   | OPEN                 |
| V <sub>DD2</sub>                 | 92                   | LCD drive 1/3 bias voltage (middle level) supply pin. This pin can be used to supply the 1/3 V <sub>DD0</sub> voltage level externally.   | -   | I   | OPEN                 |
| V <sub>DD</sub>                  | 90                   | Power supply connections. Provide a voltage of between 4.5 to 6.0V.   | -   | -   | -                    |
| V <sub>SS</sub>                  | 93                   | Power supply connections. Connect to ground.  | -   | -   | -                    |

# LC75806PTS-T

## Serial Data Input

1. 1/4 duty

(1) When CL is stopped at the low level

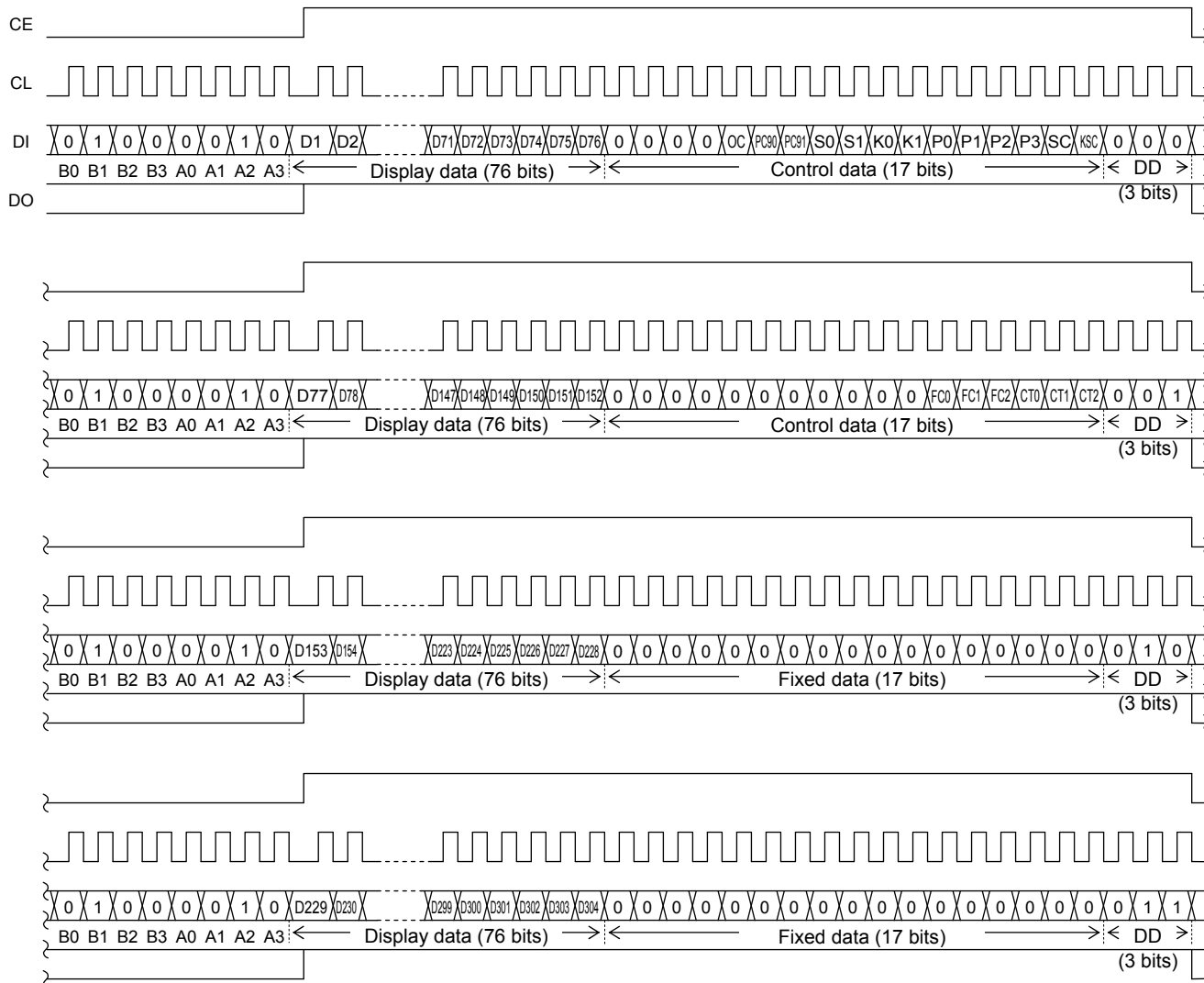

Note: B0 to B3, A0 to A3 ..... CCB address

DD ..... Direction data



# LC75806PTS-T

(2) When CL is stopped at the high level

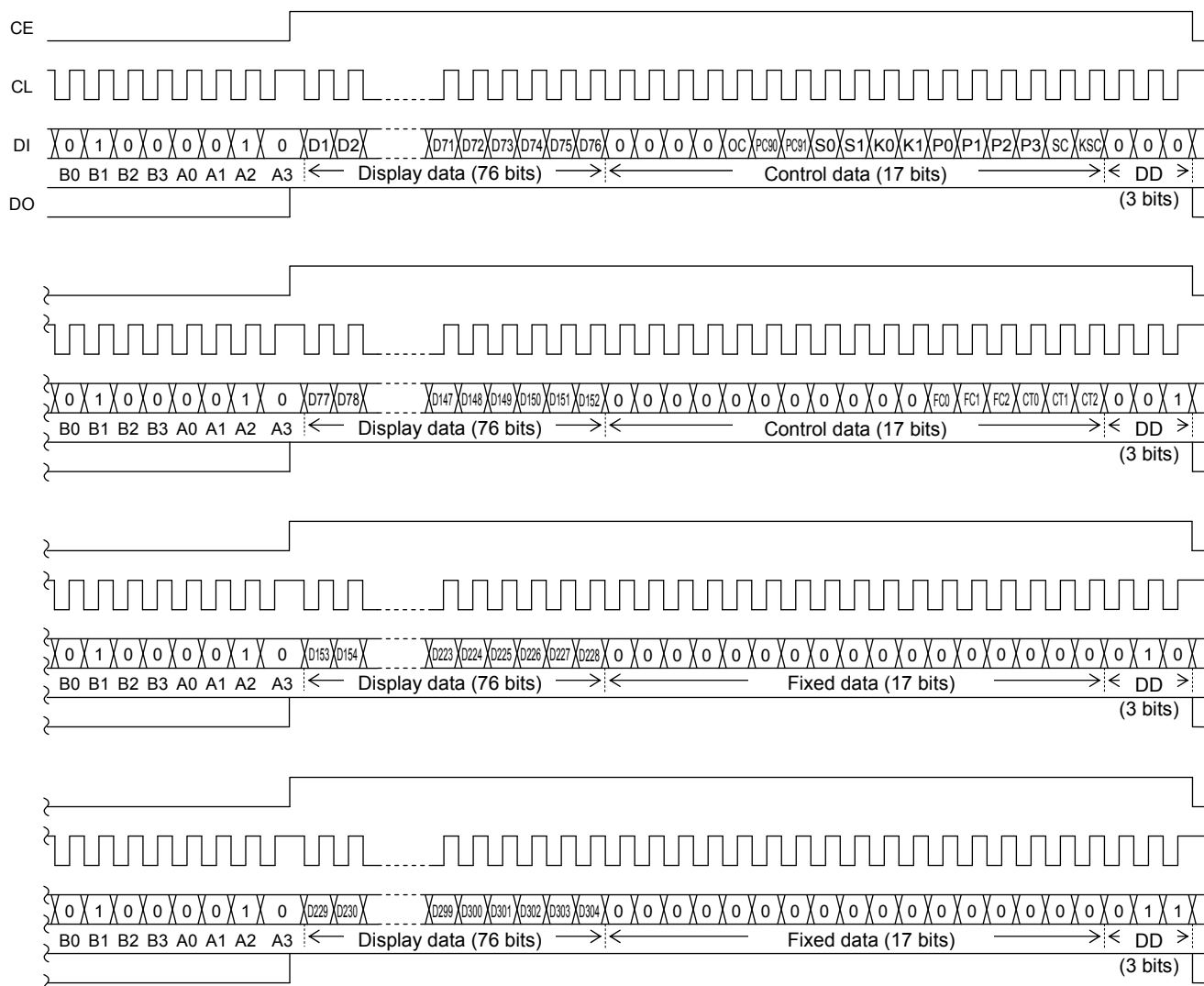

Note: B0 to B3, A0 to A3 ..... CCB address  
 DD ..... Direction data

- CCB address .....“42H”
- D1 to D304 .....Display data
- OC .....RC oscillator operating mode/external clock operationg mode switching control data
- PC90, PC91 .....General-purpose output port/clock output port/segment output port switching control data
- S0, S1 .....Sleep control data
- K0, K1 .....Key scan output/segment output switching control data
- P0 to P3 .....Segment output port/general-purpose output port switching control data
- SC .....Segment on/off control data
- KSC .....Key scan operation enabled/disabled state setting control data
- FC0 to FC2 .....Common and segment output waveform frame frequency control data
- CT0 to CT2 .....Display contrast setting control data



## LC75806PTS-T

(2) When CL is stopped at the high level

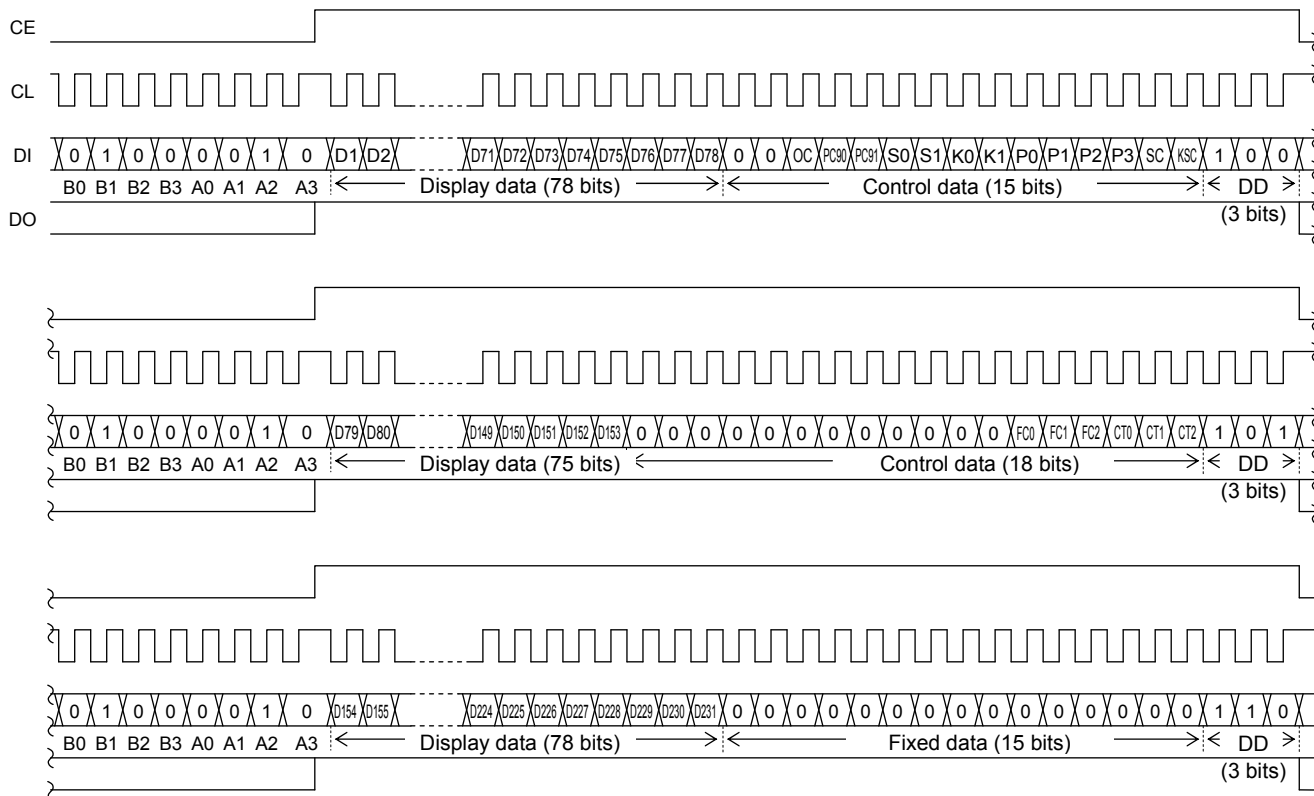

Note: B0 to B3, A0 to A3 ..... CCB address  
 DD ..... Direction data

- CCB address .....“42H”
- D1 to D231 ..... Display data
- OC ..... RC oscillator operating mode/external clock operating mode switching control data
- PC90, PC91 ..... General-purpose output port/clock output port/segment output port switching control data
- S0, S1 ..... Sleep control data
- K0, K1 ..... Key scan output/segment output switching control data
- P0 to P3 ..... Segment output port/general-purpose output port switching control data
- SC ..... Segment on/off control data
- KSC ..... Key scan operation enabled/disabled state setting control data
- FC0 to FC2 ..... Common and segment output waveform frame frequency control data
- CT0 to CT2 ..... Display contrast setting control data

**Control Data Functions**

1. OC ...RC oscillator operating mode/external clock operating mode switching control data

This control data bit selects the OSC pin function (RC oscillator operating mode or external clock operating mode)

| OC | OSC pin function              |
|----|-------------------------------|
| 0  | RC oscillator operating mode  |
| 1  | External clock operating mode |

Note: If RC oscillator operating mode is selected, connect an external resistor  $R_{OSC}$  and an external capacitor  $C_{OSC}$  to the OSC pin.

2. PC90, PC91 ... General-purpose output port/clock output port/segment output port switching control data

These control data bits switches the functions of the P9/S77 output pin between the general-purpose output port, the clock output port, and the segment output port.

| Control data |      | The state of P9/S77 output pin   |
|--------------|------|--|
| PC90         | PC91 |  |
| 0            | 0    | General-purpose output port (P9) ("L" level output)                    |
| 1            | 0    | General-purpose output port (P9) ("H" level output)                    |
| 0            | 1    | Clock output port (P9) (Clock frequency is $f_{OSC}/2$ or $f_{CK}/2$ ) |
| 1            | 1    | Segment output port (S77)  |

Note: If the sleep mode is set, the P5/S57 output pin can not be used as the clock output port.

3. S0, S1 ... Sleep control data

These control data bits switch between normal mode and sleep mode, and set the states of the KS1 to KS6 key scan output during key scan standby.

| Control data |    | Mode   | OSC pin state<br>(RC oscillator<br>or acceptance<br>of the external<br>clock signal) | Segment<br>output /<br>Common<br>output | Output pin states during key scan standby |     |     |     |     |     |
|--------------|----|--------|--|---|---|-----|-----|-----|-----|-----|
| S0           | S1 |        |  |   | KS1                                       | KS2 | KS3 | KS4 | KS5 | KS6 |
| 0            | 0  | Normal | Operating  | Operating                               | H   | H   | H   | H   | H   | H   |
| 0            | 1  | Sleep  | Stopped  | L                                       | L   | L   | L   | L   | L   | H   |
| 1            | 0  | Sleep  | Stopped  | L                                       | L   | L   | L   | L   | H   | H   |
| 1            | 1  | Sleep  | Stopped  | L                                       | H   | H   | H   | H   | H   | H   |

Note: This assumes that the KS1/S75 and KS2/S76 output pins are selected for key scan output.

4. K0, K1 ... Key scan output/segment output switching control data

These control data bits switch the functions of the KS1/S75 and KS2/S76 output pins between the key scan output and the segment output.

| Control data |    | Output pin state |         | Maximum number<br>of input keys |
|--------------|----|------------------|---------|---------------------------------|
| K0           | K1 | KS1/S75          | KS2/S76 |                                 |
| 0            | 0  | KS1              | KS2     | 30                              |
| 0            | 1  | S75              | KS2     | 25                              |
| 1            | X  | S75              | S76     | 20                              |

Note:  $KS_n$  ( $n=1$  or  $2$ ): Key scan output  
 $S_n$  ( $n=75$  or  $76$ ): Segment output

X : don't care

## LC75806PTS-T

### 5. P0 to P3 ... Segment output port/general-purpose output port switching control data

These control data bits switch the functions of the S1/P1 to S8/P8 output pins between the segment output port and the general-purpose output port.

| Control data |    |    |    | Output pin state |       |       |       |       |       |       |       |
|--------------|----|----|----|------------------|-------|-------|-------|-------|-------|-------|-------|
| P0           | P1 | P2 | P3 | S1/P1            | S2/P2 | S3/P3 | S4/P4 | S5/P5 | S6/P6 | S7/P7 | S8/P8 |
| 0            | 0  | 0  | 0  | S1               | S2    | S3    | S4    | S5    | S6    | S7    | S8    |
| 0            | 0  | 0  | 1  | P1               | S2    | S3    | S4    | S5    | S6    | S7    | S8    |
| 0            | 0  | 1  | 0  | P1               | P2    | S3    | S4    | S5    | S6    | S7    | S8    |
| 0            | 0  | 1  | 1  | P1               | P2    | P3    | S4    | S5    | S6    | S7    | S8    |
| 0            | 1  | 0  | 0  | P1               | P2    | P3    | P4    | S5    | S6    | S7    | S8    |
| 0            | 1  | 0  | 1  | P1               | P2    | P3    | P4    | P5    | S6    | S7    | S8    |
| 0            | 1  | 1  | 0  | P1               | P2    | P3    | P4    | P5    | P6    | S7    | S8    |
| 0            | 1  | 1  | 1  | P1               | P2    | P3    | P4    | P5    | P6    | P7    | S8    |
| 1            | 0  | 0  | 0  | P1               | P2    | P3    | P4    | P5    | P6    | P7    | P8    |

Note: Sn (n=1 to 8): Segment output port

Pn (n=1 to 8): General-purpose output port

The table below lists the correspondence between the display data and the output pins when these pins are selected to be general-purpose output ports.

| Output pin | Correspondence display data |          |
|------------|-----------------------------|----------|
|            | 1/4 duty                    | 1/3 duty |
| S1/P1      | D1                          | D1       |
| S2/P2      | D5                          | D4       |
| S3/P3      | D9                          | D7       |
| S4/P4      | D13                         | D10      |
| S5/P5      | D17                         | D13      |
| S6/P6      | D21                         | D16      |
| S7/P7      | D25                         | D19      |
| S8/P8      | D29                         | D22      |

For example, if the circuit is operated in 1/4 duty and the S4/P4 output pin is selected to be a general-purpose output port, the S4/P4 output pin will output a high level when the display data D13 is 1, and will output a low level when D13 is 0.

### 6. SC ... Segment on/off control data

This control data bit controls the on/off state of the segments.

| SC | Display state |
|----|---------------|
| 0  | On            |
| 1  | Off           |

However, note that when the segments are turned off by setting SC to 1, the segments are turned off by outputting segment off waveforms from the segment output pins.

### 7. KSC ... Key scan operation enabled/disabled state setting control data

This control data bit enables or disables key scan operation.

| KSC | Key scan operating state   |
|-----|--|
| 0   | Key scan operation enabled<br>(A key scan operation is performed if any key on the lines corresponding to KS1 to KS6 pin which is set high is pressed.)  |
| 1   | Key scan operation disabled<br>(No key scan operation is performed, even if any of the keys in the key matrix are pressed.<br>If this state is set up, the key data is forcibly reset to 0 and the key data read request is also cleared.<br>(DO is set high.) |

## LC75806PTS-T

### 8. FC0 to FC2 ... Common and segment output waveform frame frequency control data

These control data bits set the common and segment output waveform frequency.

| Control data |     |     | Frame frequency<br>$f_O$ [Hz] |
|--------------|-----|-----|-------------------------------|
| FC0          | FC1 | FC2 |                               |
| 1            | 1   | 0   | $f_{OSC}/768, f_{CK}/768$     |
| 1            | 1   | 1   | $f_{OSC}/576, f_{CK}/576$     |
| 0            | 0   | 0   | $f_{OSC}/384, f_{CK}/384$     |
| 0            | 0   | 1   | $f_{OSC}/288, f_{CK}/288$     |
| 0            | 1   | 0   | $f_{OSC}/192, f_{CK}/192$     |

### 9. CT0 to CT2 ... Display contrast setting control data

Set the display contrast with this control data.

CT0 to CT2: Sets the display contrast (7 steps)

| CT0 | CT1 | CT2 | LCD drive 3/3 bias voltage $V_{DD0}$ level |
|-----|-----|-----|--|
| 0   | 0   | 0   | $1.00V_{DD}=V_{DD}-(0.05V_{DD}\times 0)$   |
| 1   | 0   | 0   | $0.95V_{DD}=V_{DD}-(0.05V_{DD}\times 1)$   |
| 0   | 1   | 0   | $0.90V_{DD}=V_{DD}-(0.05V_{DD}\times 2)$   |
| 1   | 1   | 0   | $0.85V_{DD}=V_{DD}-(0.05V_{DD}\times 3)$   |
| 0   | 0   | 1   | $0.80V_{DD}=V_{DD}-(0.05V_{DD}\times 4)$   |
| 1   | 0   | 1   | $0.75V_{DD}=V_{DD}-(0.05V_{DD}\times 5)$   |
| 0   | 1   | 1   | $0.70V_{DD}=V_{DD}-(0.05V_{DD}\times 6)$   |

Note that although the display contrast can be adjusted by operating the built-in display contrast adjustment circuit, it can also be adjusted by modifying the supply pin  $V_{DD}$  voltage level.

## Display Data and Output Pin Correspondence

### 1. 1/4 duty

| Output pin | COM1 | COM2 | COM3 | COM4 |
|------------|------|------|------|------|
| S1/P1      | D1   | D2   | D3   | D4   |
| S2/P2      | D5   | D6   | D7   | D8   |
| S3/P3      | D9   | D10  | D11  | D12  |
| S4/P4      | D13  | D14  | D15  | D16  |
| S5/P5      | D17  | D18  | D19  | D20  |
| S6/P6      | D21  | D22  | D23  | D24  |
| S7/P7      | D25  | D26  | D27  | D28  |
| S8/P8      | D29  | D30  | D31  | D32  |
| S9         | D33  | D34  | D35  | D36  |
| S10        | D37  | D38  | D39  | D40  |
| S11        | D41  | D42  | D43  | D44  |
| S12        | D45  | D46  | D47  | D48  |
| S13        | D49  | D50  | D51  | D52  |
| S14        | D53  | D54  | D55  | D56  |
| S15        | D57  | D58  | D59  | D60  |
| S16        | D61  | D62  | D63  | D64  |
| S17        | D65  | D66  | D67  | D68  |
| S18        | D69  | D70  | D71  | D72  |
| S19        | D73  | D74  | D75  | D76  |
| S20        | D77  | D78  | D79  | D80  |
| S21        | D81  | D82  | D83  | D84  |
| S22        | D85  | D86  | D87  | D88  |
| S23        | D89  | D90  | D91  | D92  |
| S24        | D93  | D94  | D95  | D96  |
| S25        | D97  | D98  | D99  | D100 |

| Output pin | COM1 | COM2 | COM3 | COM4 |
|------------|------|------|------|------|
| S26        | D101 | D102 | D103 | D104 |
| S27        | D105 | D106 | D107 | D108 |
| S28        | D109 | D110 | D111 | D112 |
| S29        | D113 | D114 | D115 | D116 |
| S30        | D117 | D118 | D119 | D120 |
| S31        | D121 | D122 | D123 | D124 |
| S32        | D125 | D126 | D127 | D128 |
| S33        | D129 | D130 | D131 | D132 |
| S34        | D133 | D134 | D135 | D136 |
| S35        | D137 | D138 | D139 | D140 |
| S36        | D141 | D142 | D143 | D144 |
| S37        | D145 | D146 | D147 | D148 |
| S38        | D149 | D150 | D151 | D152 |
| S39        | D153 | D154 | D155 | D156 |
| S40        | D157 | D158 | D159 | D160 |
| S41        | D161 | D162 | D163 | D164 |
| S42        | D165 | D166 | D167 | D168 |
| S43        | D169 | D170 | D171 | D172 |
| S44        | D173 | D174 | D175 | D176 |
| S45        | D177 | D178 | D179 | D180 |
| S46        | D181 | D182 | D183 | D184 |
| S47        | D185 | D186 | D187 | D188 |
| S48        | D189 | D190 | D191 | D192 |
| S49        | D193 | D194 | D195 | D196 |
| S50        | D197 | D198 | D199 | D200 |

Note: This is for the case where the S1/P1 to S8/P8, KS1/S75, KS2/S76, P9/S77 output pins are selected for use as segment outputs.

Continued on next page.

## LC75806PTS-T

Continued from preceding page.

| Output pin | COM1 | COM2 | COM3 | COM4 |
|------------|------|------|------|------|
| S51        | D201 | D202 | D203 | D204 |
| S52        | D205 | D206 | D207 | D208 |
| S53        | D209 | D210 | D211 | D212 |
| S54        | D213 | D214 | D215 | D216 |
| S55        | D217 | D218 | D219 | D220 |
| S56        | D221 | D222 | D223 | D224 |
| S57        | D225 | D226 | D227 | D228 |
| S58        | D229 | D230 | D231 | D232 |
| S59        | D233 | D234 | D235 | D236 |
| S60        | D237 | D238 | D239 | D240 |
| S61        | D241 | D242 | D243 | D244 |
| S62        | D245 | D246 | D247 | D248 |
| S63        | D249 | D250 | D251 | D252 |

| Output pin | COM1 | COM2 | COM3 | COM4 |
|------------|------|------|------|------|
| S64        | D253 | D254 | D255 | D256 |
| S65        | D257 | D258 | D259 | D260 |
| S66        | D261 | D262 | D263 | D264 |
| S67        | D265 | D266 | D267 | D268 |
| S68        | D269 | D270 | D271 | D272 |
| S69        | D273 | D274 | D275 | D276 |
| S70        | D277 | D278 | D279 | D280 |
| S71        | D281 | D282 | D283 | D284 |
| S72        | D285 | D286 | D287 | D288 |
| S73        | D289 | D290 | D291 | D292 |
| KS1/S75    | D293 | D294 | D295 | D296 |
| KS2/S76    | D297 | D298 | D299 | D300 |
| P9/S77     | D301 | D302 | D303 | D304 |

Note: This is for the case where the S1/P1 to S8/P8, KS1/S75, KS2/S76, P9/S77 output pins are selected for use as segment outputs.

For example, the table below lists the segment output states for the S11 output pin.

| Display data |     |     |     | Output pin state (S11)                                  |
|--------------|-----|-----|-----|---|
| D41          | D42 | D43 | D44 |   |
| 0            | 0   | 0   | 0   | The LCD segments for COM1, COM2, COM3 and COM4 are off. |
| 0            | 0   | 0   | 1   | The LCD segment for COM4 is on.                         |
| 0            | 0   | 1   | 0   | The LCD segment for COM3 is on.                         |
| 0            | 0   | 1   | 1   | The LCD segments for COM3 and COM4 are on.              |
| 0            | 1   | 0   | 0   | The LCD segment for COM2 is on.                         |
| 0            | 1   | 0   | 1   | The LCD segments for COM2 and COM4 are on.              |
| 0            | 1   | 1   | 0   | The LCD segments for COM2 and COM3 are on.              |
| 0            | 1   | 1   | 1   | The LCD segments for COM2, COM3 and COM4 are on.        |
| 1            | 0   | 0   | 0   | The LCD segment for COM1 is on.                         |
| 1            | 0   | 0   | 1   | The LCD segments for COM1 and COM4 are on.              |
| 1            | 0   | 1   | 0   | The LCD segments for COM1 and COM3 are on.              |
| 1            | 0   | 1   | 1   | The LCD segments for COM1, COM3 and COM4 are on.        |
| 1            | 1   | 0   | 0   | The LCD segments for COM1 and COM2 are on.              |
| 1            | 1   | 0   | 1   | The LCD segments for COM1, COM2 and COM4 are on.        |
| 1            | 1   | 1   | 0   | The LCD segments for COM1, COM2 and COM3 are on.        |
| 1            | 1   | 1   | 1   | The LCD segments for COM1, COM2, COM3 and COM4 are on.  |

## LC75806PTS-T

### 2. 1/3 duty

| Output pin | COM1 | COM2 | COM3 |
|------------|------|------|------|
| S1/P1      | D1   | D2   | D3   |
| S2/P2      | D4   | D5   | D6   |
| S3/P3      | D7   | D8   | D9   |
| S4/P4      | D10  | D11  | D12  |
| S5/P5      | D13  | D14  | D15  |
| S6/P6      | D16  | D17  | D18  |
| S7/P7      | D19  | D20  | D21  |
| S8/P8      | D22  | D23  | D24  |
| S9         | D25  | D26  | D27  |
| S10        | D28  | D29  | D30  |
| S11        | D31  | D32  | D33  |
| S12        | D34  | D35  | D36  |
| S13        | D37  | D38  | D39  |
| S14        | D40  | D41  | D42  |
| S15        | D43  | D44  | D45  |
| S16        | D46  | D47  | D48  |
| S17        | D49  | D50  | D51  |
| S18        | D52  | D53  | D54  |
| S19        | D55  | D56  | D57  |
| S20        | D58  | D59  | D60  |
| S21        | D61  | D62  | D63  |
| S22        | D64  | D65  | D66  |
| S23        | D67  | D68  | D69  |
| S24        | D70  | D71  | D72  |
| S25        | D73  | D74  | D75  |
| S26        | D76  | D77  | D78  |
| S27        | D79  | D80  | D81  |
| S28        | D82  | D83  | D84  |
| S29        | D85  | D86  | D87  |
| S30        | D88  | D89  | D90  |
| S31        | D91  | D92  | D93  |
| S32        | D94  | D95  | D96  |
| S33        | D97  | D98  | D99  |
| S34        | D100 | D101 | D102 |
| S35        | D103 | D104 | D105 |
| S36        | D106 | D107 | D108 |
| S37        | D109 | D110 | D111 |
| S38        | D112 | D113 | D114 |
| S39        | D115 | D116 | D117 |

| Output pin | COM1 | COM2 | COM3 |
|------------|------|------|------|
| S40        | D118 | D119 | D120 |
| S41        | D121 | D122 | D123 |
| S42        | D124 | D125 | D126 |
| S43        | D127 | D128 | D129 |
| S44        | D130 | D131 | D132 |
| S45        | D133 | D134 | D135 |
| S46        | D136 | D137 | D138 |
| S47        | D139 | D140 | D141 |
| S48        | D142 | D143 | D144 |
| S49        | D145 | D146 | D147 |
| S50        | D148 | D149 | D150 |
| S51        | D151 | D152 | D153 |
| S52        | D154 | D155 | D156 |
| S53        | D157 | D158 | D159 |
| S54        | D160 | D161 | D162 |
| S55        | D163 | D164 | D165 |
| S56        | D166 | D167 | D168 |
| S57        | D169 | D170 | D171 |
| S58        | D172 | D173 | D174 |
| S59        | D175 | D176 | D177 |
| S60        | D178 | D179 | D180 |
| S61        | D181 | D182 | D183 |
| S62        | D184 | D185 | D186 |
| S63        | D187 | D188 | D189 |
| S64        | D190 | D191 | D192 |
| S65        | D193 | D194 | D195 |
| S66        | D196 | D197 | D198 |
| S67        | D199 | D200 | D201 |
| S68        | D202 | D203 | D204 |
| S69        | D205 | D206 | D207 |
| S70        | D208 | D209 | D210 |
| S71        | D211 | D212 | D213 |
| S72        | D214 | D215 | D216 |
| S73        | D217 | D218 | D219 |
| COM4/S74   | D220 | D221 | D222 |
| KS1/S75    | D223 | D224 | D225 |
| KS2/S76    | D226 | D227 | D228 |
| P9/S77     | D229 | D230 | D231 |

Note: This is for the case where the S1/P1 to S8/P8, KS1/S75, KS2/S76, P9/S77 output pins are selected for use as segment outputs.



# LC75806PTS-T

For example, the table below lists the segment output states for the S11 output pin.

| Display data |     |     | Output pin state (S11)                             |
|--------------|-----|-----|--|
| D31          | D32 | D33 |  |
| 0            | 0   | 0   | The LCD segments for COM1, COM2, and COM3 are off. |
| 0            | 0   | 1   | The LCD segment for COM3 is on.                    |
| 0            | 1   | 0   | The LCD segment for COM2 is on.                    |
| 0            | 1   | 1   | The LCD segments for COM2 and COM3 are on.         |
| 1            | 0   | 0   | The LCD segment for COM1 is on.                    |
| 1            | 0   | 1   | The LCD segments for COM1 and COM3 are on.         |
| 1            | 1   | 0   | The LCD segments for COM1 and COM2 are on.         |
| 1            | 1   | 1   | The LCD segments for COM1, COM2 and COM3 are on.   |

## Serial Data Output

1. When CL is stopped at the low level

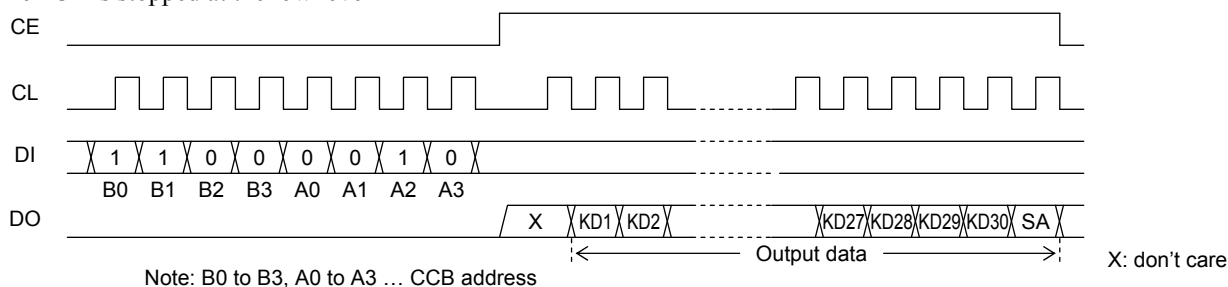

2. When CL is stopped at the high level

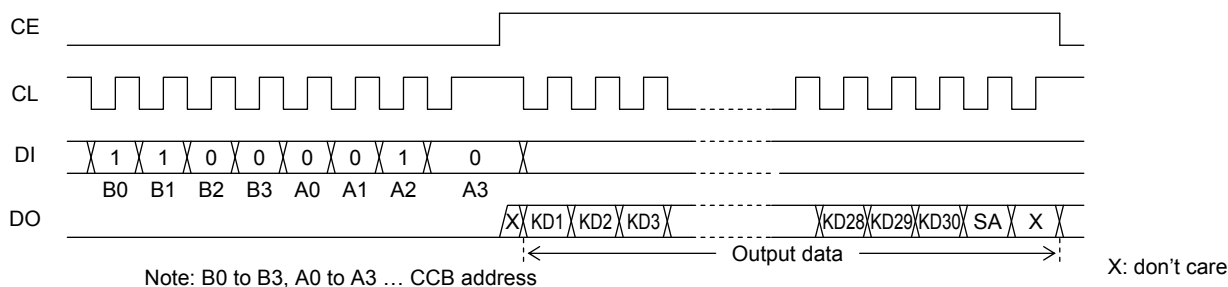

- CCB address ... “43H”
- KD1 to KD30 ... Key data
- SA ..... Sleep acknowledge data

Note: If a key data read operation is executed when DO is high (DO does not generate a key data read request output), the read key data (KD1 to KD30) and sleep acknowledge data (SA) will be invalid.

**Output Data**

1. KD1 to KD30 ... Key data

When a key matrix of up to 30 keys is formed from the KS1 to KS6 output pins and KI1 to KI5 input pins and one of those keys is pressed, the key output data corresponding to that key will be set to 1. The table shows the relationship between those pins and the key data bits.

|         | KI1  | KI2  | KI3  | KI4  | KI5  |
|---------|------|------|------|------|------|
| KS1/S75 | KD1  | KD2  | KD3  | KD4  | KD5  |
| KS2/S76 | KD6  | KD7  | KD8  | KD9  | KD10 |
| KS3     | KD11 | KD12 | KD13 | KD14 | KD15 |
| KS4     | KD16 | KD17 | KD18 | KD19 | KD20 |
| KS5     | KD21 | KD22 | KD23 | KD24 | KD25 |
| KS6     | KD26 | KD27 | KD28 | KD29 | KD30 |

When the KS1/S75 and KS2/S76 output pins are selected to be segment outputs by control data bits K0 and K1 and a key matrix of up to 20 keys is formed using the KS3 to KS6 output pins and the KI1 to KI5 input pins, the KD1 to KD10 key data bits will be set to 0.

2. SA ... Sleep acknowledge data

This output data bit is set to the state when the key was pressed. Also, while DO will be low in this case, if serial data is input and the mode is set (to normal or sleep mode) during this period, that mode will be set. SA will be 1 in sleep mode and 0 in normal mode.

**Sleep Mode Functions**

Sleep mode is set up by setting S0 or S1 in the control data to 1. When sleep mode is set up, both the segment and common outputs will go to the low level. In RC oscillator operating mode (OC = 0), the oscillator on the OSC pin will stop (although it will operate during key scan operations), and in external clock operating mode (OC = 1), acceptance of the external clock signal on the OSC pin will stop (although the clock signal will be accepted during key scan operations). Thus this mode reduces power consumption. However, the S1/P1 to S8/P8, P9/S77 output pins can be used as general-purpose output ports under control of the P0 to P3, PC90 and PC91 bits in the control data even in sleep mode (The P9/S77 output pin can not be used as clock output port). Sleep mode is cancelled by setting both S0 and S1 in control data to 0.

**Key Scan Operation Functions**

1. Key scan timing

The key scan period is 288T[s]. To reliably determine the on/off state of the keys, the LC75806PTS-T scans the keys twice and determines that a key has been pressed when the key data agrees. It outputs a key data read request (a low level on DO) 615T[s] after starting a key scan. If the key data does not agree and a key was pressed at that point, it scans the keys again. Thus the LC75806PTS-T cannot detect a key press shorter than 615T[s].

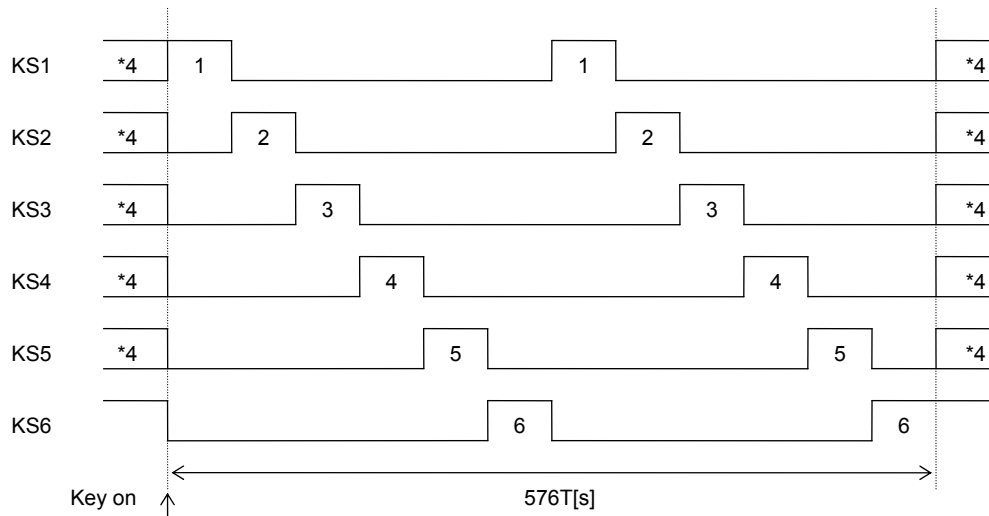

$$T = \frac{1}{f_{OSC}} = \frac{1}{f_{CK}}$$

Note: \*4. These are set to the high or low level by the S0 and S1 bits in the control data.  
Key scan output signals are not output from pins that are set to the low level.

## LC75806PTS-T

### 2. Normal mode, when key scan operations are enabled

- (1) The KS1 to KS6 pins are set high. (See the description of the control data.)
- (2) When a key is pressed, a key scan is started and the keys are scanned until all keys are released. Multiple key presses are recognized by determining whether multiple key data bits are set.
- (3) If a key is pressed for longer than  $615T[s]$  (Where  $T = 1/f_{OSC}$  or  $T = 1/f_{CK}$ ), the LC75806PTS-T outputs a key data read request (a low level on DO) to the controller. The controller acknowledges this request and reads the key data. However, if CE is high during a serial data transfer, DO will be set high.
- (4) After the controller reads the key data, the key data read request is cleared (DO is set high) and the LC75806PTS-T performs another key scan. Also note that DO, being an open-drain output, requires a pull-up resistor (between 1 and  $10k\Omega$ ).

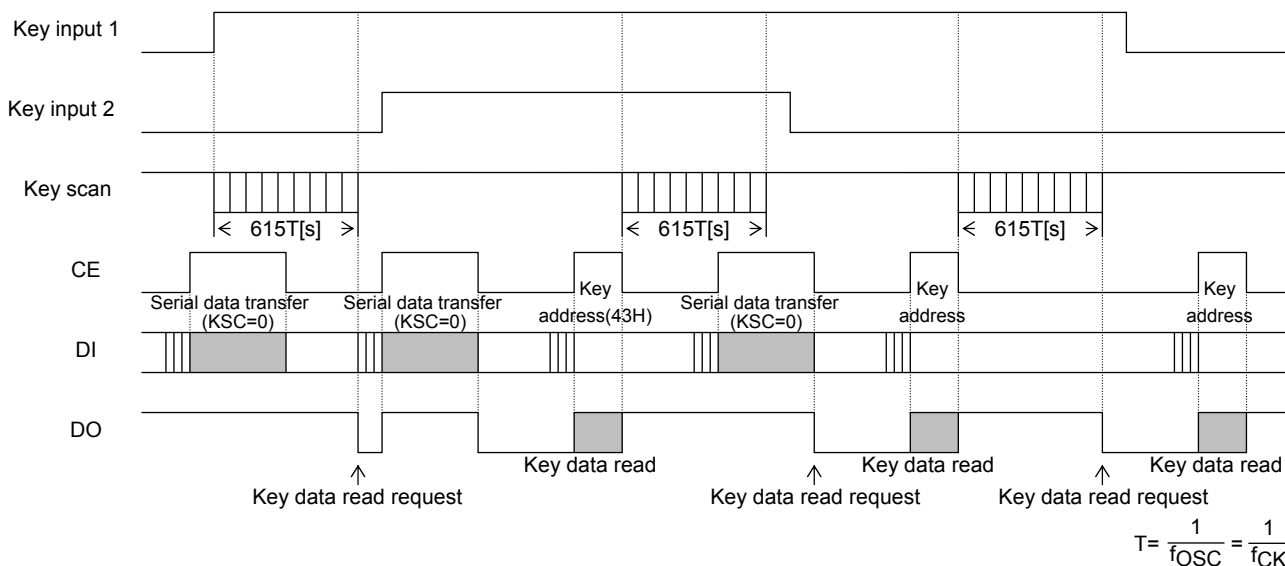

### 3. Sleep mode, when key scan operations are enabled

- (1) The KS1 to KS6 pins are set to high or low level by the S0 and S1 bits in the control data. (See the description of the control data.)
- (2) If a key on one of the lines corresponding to a KS1 to KS6 pin which is set high is pressed, the oscillator on the OSC pins starts in RC oscillator operating mode (the IC starts accepting the external clock signal in external clock operating mode) and a key scan is performed. Keys are scanned until all keys are released. Multiple key presses are recognized by determining whether multiple key data bits are set.
- (3) If a key is pressed for longer than  $615T[s]$  (Where  $T = 1/f_{OSC}$  or  $T = 1/f_{CK}$ ), the LC75806PTS-T outputs a key data read request (a low level on DO) to the controller. The controller acknowledges this request and reads the key data. However, if CE is high during a serial data transfer, DO will be set high.
- (4) After the controller reads the key data, the key data read request is cleared (DO is set high) and the LC75806PTS-T performs another key scan. However, this does not clear sleep mode. Also note that DO, being an open-drain output, requires a pull-up resistor (between 1 and  $10 k\Omega$ ).
- (5) Sleep mode key scan example

Example: S0=0, S1=1 (Sleep with only KS6 high)

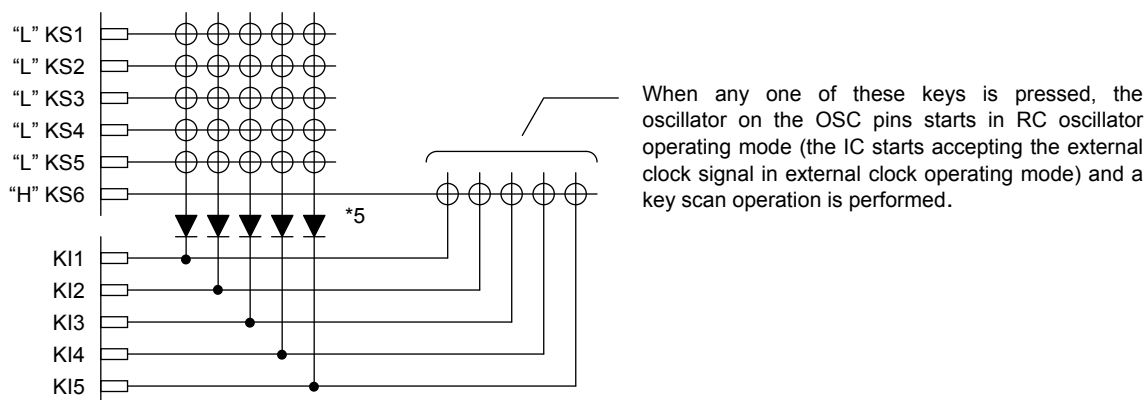

Note: \*5. These diodes are required to reliably recognize multiple key presses on the KS6 line when sleep mode state with only KS6 high, as in the above example. That is, these diodes prevent incorrect operations due to sneak currents in the KS6 key scan output signal when keys on the KS1 to KS5 lines are pressed at the same time.

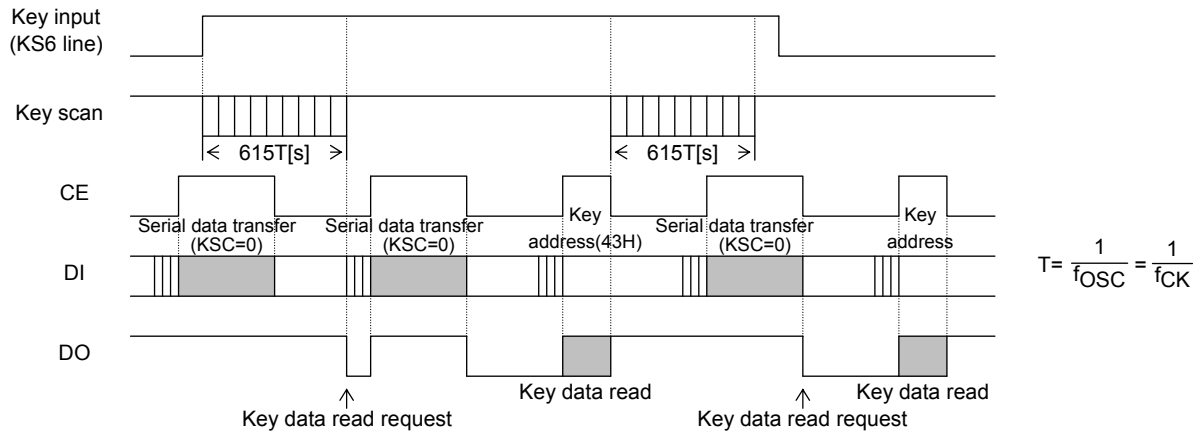

4. Normal/sleep mode, when key scan operations are disabled

- (1) The KS1 to KS6 pins are set to high or low level by the S0 and S1 bits in the control data.
- (2) No key scan operation is performed, whichever key is pressed.
- (3) If the key scan disabled state (KSC = 1 in the control data) is set during a key scan, the key scan is stopped.
- (4) If the key scan disabled state (KSC = 1 in the control data) is set when a key data read request (a low level on DO) is output to the controller, all the key data is set to 0 and the key data read request is cleared (DO is set high).
- Note that DO, being an open-drain output, requires a pull-up resistor (between 1 to 10 kΩ).
- (5) The key scan disabled state is cleared by setting KSC in the control data to 0.

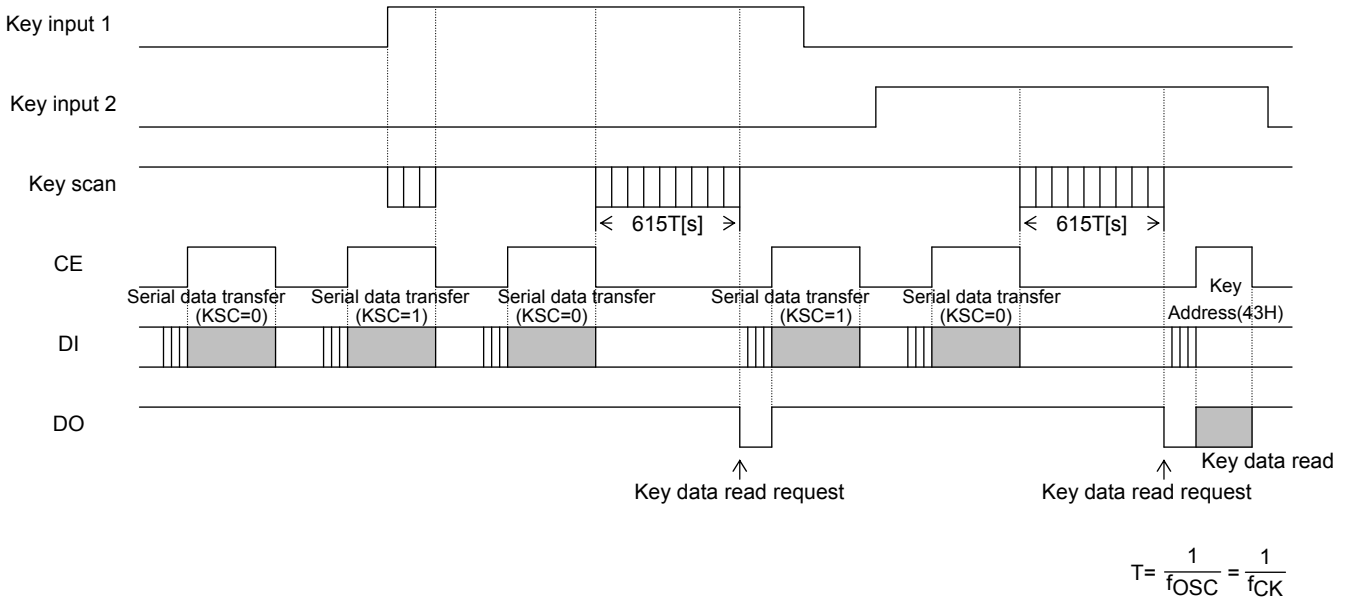

**Multiple Key Presses**

Although the LC75806PTS-T is capable of key scanning without inserting diodes for dual key presses, triple key presses on the KI1 to KI5 input pin lines, or multiple key presses on the KS1 to KS6 output pin lines, multiple presses other than these cases may result in keys that were not pressed recognized as having been pressed. Therefore, a diode must be inserted in series with each key. Applications that do not recognize multiple key presses of three or more keys should check the key data for three or more 1 bits and ignore such data.

# LC75806PTS-T

## 1/4 Duty, 1/3 Bias Drive Technique

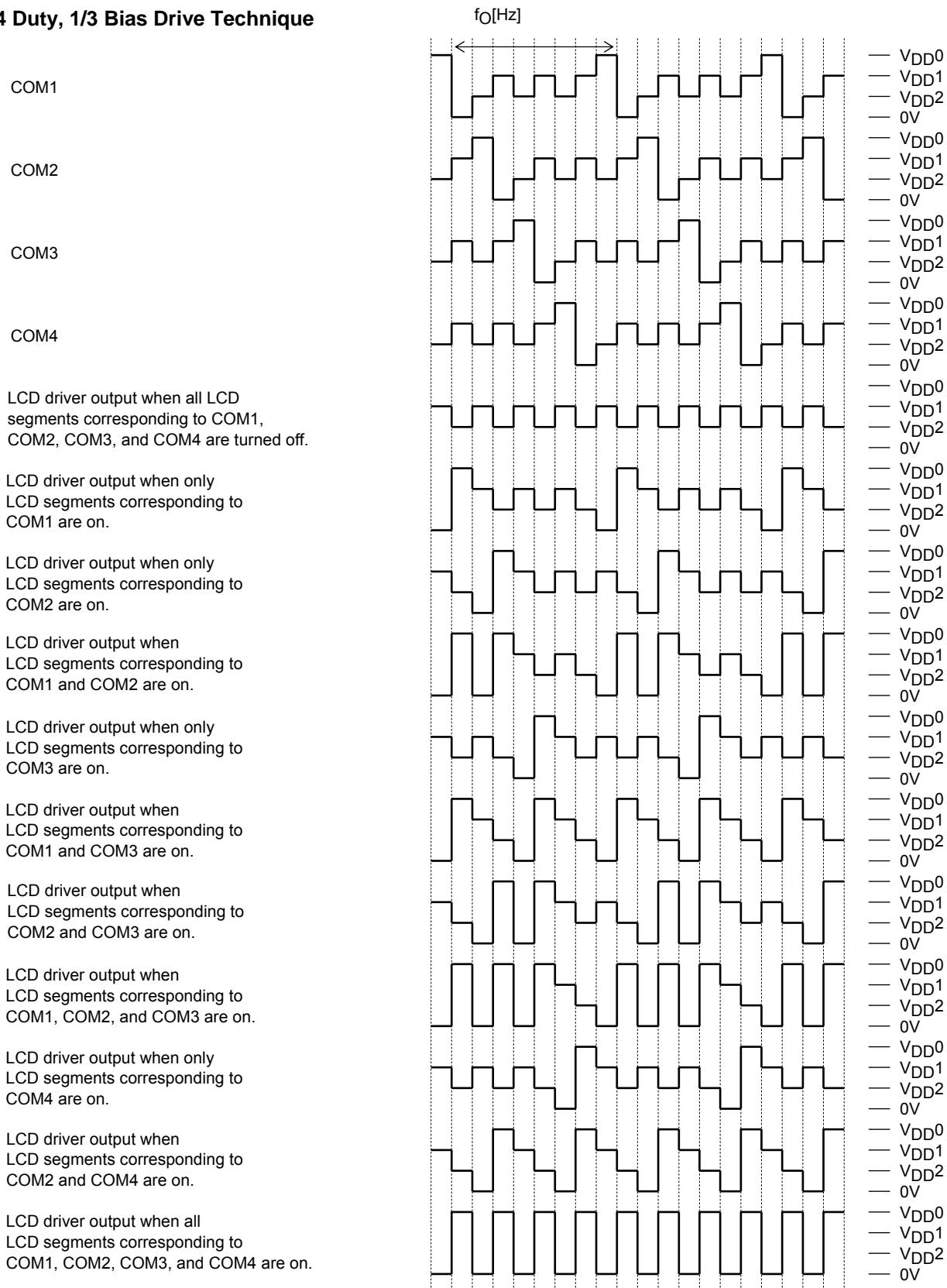

LCD driver output when all LCD segments corresponding to COM1, COM2, COM3, and COM4 are turned off.

LCD driver output when only LCD segments corresponding to COM1 are on.

LCD driver output when only LCD segments corresponding to COM2 are on.

LCD driver output when LCD segments corresponding to COM1 and COM2 are on.

LCD driver output when only LCD segments corresponding to COM3 are on.

LCD driver output when LCD segments corresponding to COM1 and COM3 are on.

LCD driver output when LCD segments corresponding to COM2 and COM3 are on.

LCD driver output when LCD segments corresponding to COM1, COM2, and COM3 are on.

LCD driver output when only LCD segments corresponding to COM4 are on.

LCD driver output when LCD segments corresponding to COM2 and COM4 are on.

LCD driver output when all LCD segments corresponding to COM1, COM2, COM3, and COM4 are on.

| Control data |     |     | Common and segment output waveform<br>frame frequency $f_O$ [Hz] |
|--------------|-----|-----|--|
| FC0          | FC1 | FC2 |  |
| 1            | 1   | 0   | $f_{OSC}/768, f_{CK}/768$  |
| 1            | 1   | 1   | $f_{OSC}/576, f_{CK}/576$  |
| 0            | 0   | 0   | $f_{OSC}/384, f_{CK}/384$  |
| 0            | 0   | 1   | $f_{OSC}/288, f_{CK}/288$  |
| 0            | 1   | 0   | $f_{OSC}/192, f_{CK}/192$  |

# LC75806PTS-T

## 1/3 Duty, 1/3 Bias Drive Technique

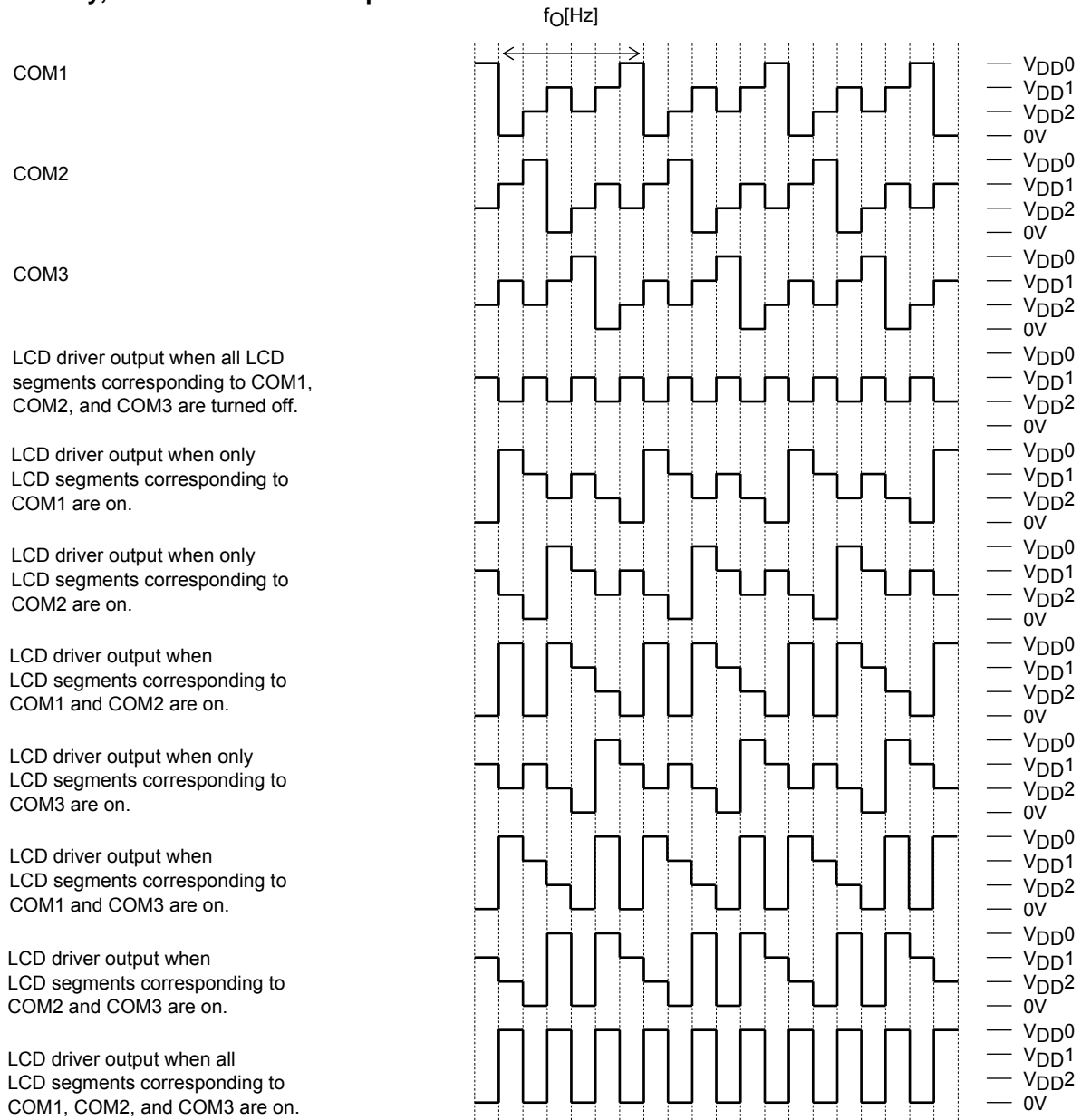

| Control data |     |     | Common and segment output waveform<br>frame frequency $f_O$ [Hz] |
|--------------|-----|-----|--|
| FC0          | FC1 | FC2 |  |
| 1            | 1   | 0   | $f_{OSC}/768, f_{CK}/768$  |
| 1            | 1   | 1   | $f_{OSC}/576, f_{CK}/576$  |
| 0            | 0   | 0   | $f_{OSC}/384, f_{CK}/384$  |
| 0            | 0   | 1   | $f_{OSC}/288, f_{CK}/288$  |
| 0            | 1   | 0   | $f_{OSC}/192, f_{CK}/192$  |

**Clock Signal Output Waveform**

| Control data |      | The state of P9/S77 output pin   |
|--------------|------|--|
| PC90         | PC91 |  |
| 0            | 1    | Clock output port (P9) (Clock frequency is $f_{OSC}/2$ or $f_{CK}/2$ ) |

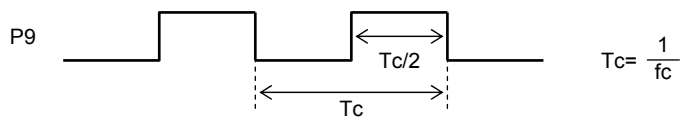

**Voltage Detection Type Reset Circuit (VDET)**

This circuit generates an output signal and resets the system when power is first applied and when the voltage drops, i.e., when the power supply voltage is less than or equal to the power down detection voltage  $V_{DET}$ , which is 2.3 V, typical. To assure that this function operates reliably, a capacitor must be added to the power supply line so that the power supply voltage  $V_{DD}$  rise time when the power is first applied and the power supply voltage  $V_{DD}$  fall time when the voltage drops are both at least 1ms. (See Figure 5 and Figure 6.)

**System Reset**

The LC75806PTS-T supports the reset methods described below. When a system reset is applied, display is turned off, key scanning is stopped, all the key data is reset to low, and the general-purpose output ports are fixed at the low level (The S1/P1 to S8/P8 pins are forcibly set to the segment output port function and fixed at the low level. The P9/S77 pin is forcibly set to the general-purpose output port function and fixed at the low level). When the reset is cleared, display is turned on, key scanning is enabled and the general-purpose output ports state setting is enabled.

1. Reset methods

(1) Reset method by the voltage detection type reset circuit ( $V_{DET}$ )

If at least 1ms is assured as the supply voltage  $V_{DD}$  rise time when power is applied, a system reset will be applied by the  $V_{DET}$  output signal when the supply voltage is brought up. If at least 1 ms is assured as the supply voltage  $V_{DD}$  fall time when power drops, a system reset will be applied in the same manner by the  $V_{DET}$  output signal when the supply voltage is lowered. Note that the reset is cleared at the point when all the serial data (1/4 duty: the display data D1 to D304 and the control data, 1/3 duty: the display data D1 to D231 and the control data) has been transferred, i.e., on the fall of the CE signal on the transfer of the last direction data, after all the direction data has been transferred. (See Figure 5 and Figure 6.)

• 1/4 duty

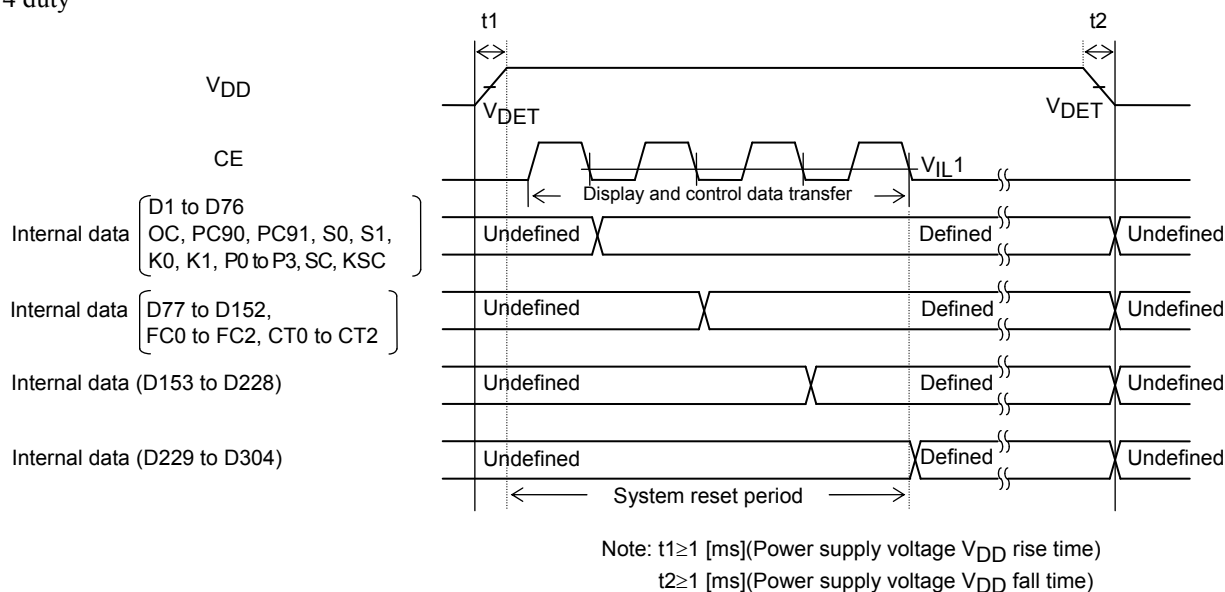

[Figure 5]

- 1/3 duty

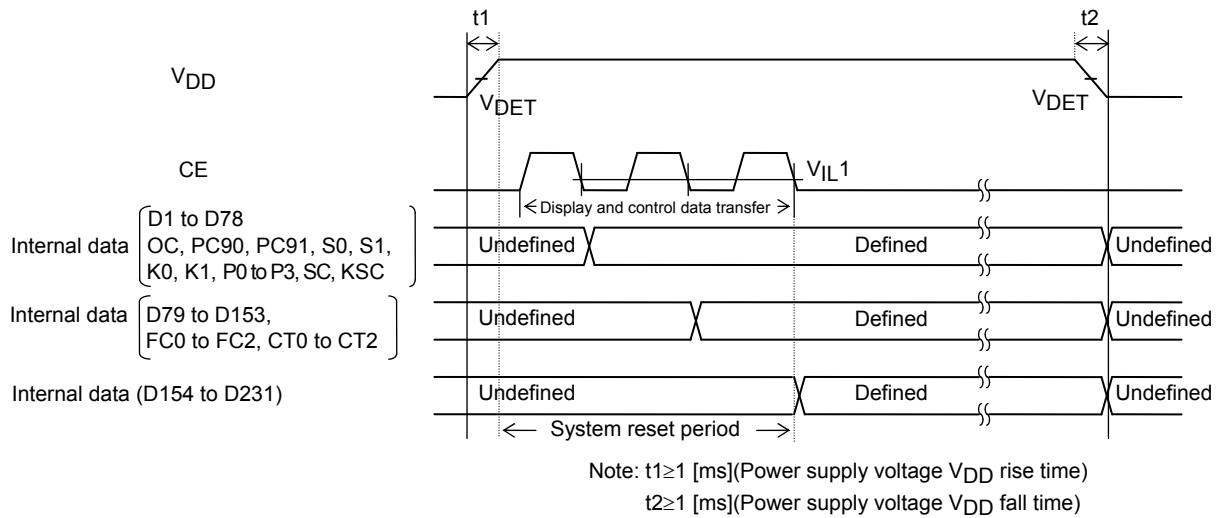

[Figure 6]

(2) Reset method by the  $\overline{RES}$  pin

When power is applied, a system reset is applied by setting the  $\overline{RES}$  pin low level. The reset is cleared by setting the  $\overline{RES}$  pin high level after all the serial data (1/4 duty: the display data D1 to D304 and the control data, 1/3 duty: the display data D1 to D231 and the control data) has been transferred.

In the allowable operating range ( $V_{DD} = 4.5$  to  $6.0$  V), A reset is applied by setting the  $\overline{RES}$  pin low level. and the reset is cleared by setting the  $\overline{RES}$  pin high level.

2. Internal block states during the reset period

- **CLOCK GENERATOR**  
A reset is applied and either the OSC pin oscillator is stopped or external clock reception is stopped
- **COMMON DRIVER, SEGMENT DRIVER & LATCH**  
A reset is applied and the display is turned off. However, display data can be input to the latch circuit in this state.
- **CONTRAST ADJUSTER**  
A reset is applied and the display contrast adjustment circuit operation is disabled.
- **KEY SCAN**  
A reset is applied, the circuit is set to the initial state, and at the same time the key scan operation is disabled.
- **KEY BUFFER**  
A reset is applied and all the key data is set to low.
- **GENERAL PURPOSE PORT**  
A reset is applied, the circuit is set to the initial state.
- **CCB INTERFACE, SHIFT REGISTER, CONTROL REGISTER**  
Since serial data transfer is possible, these circuits are not reset.



# LC75806PTS-T

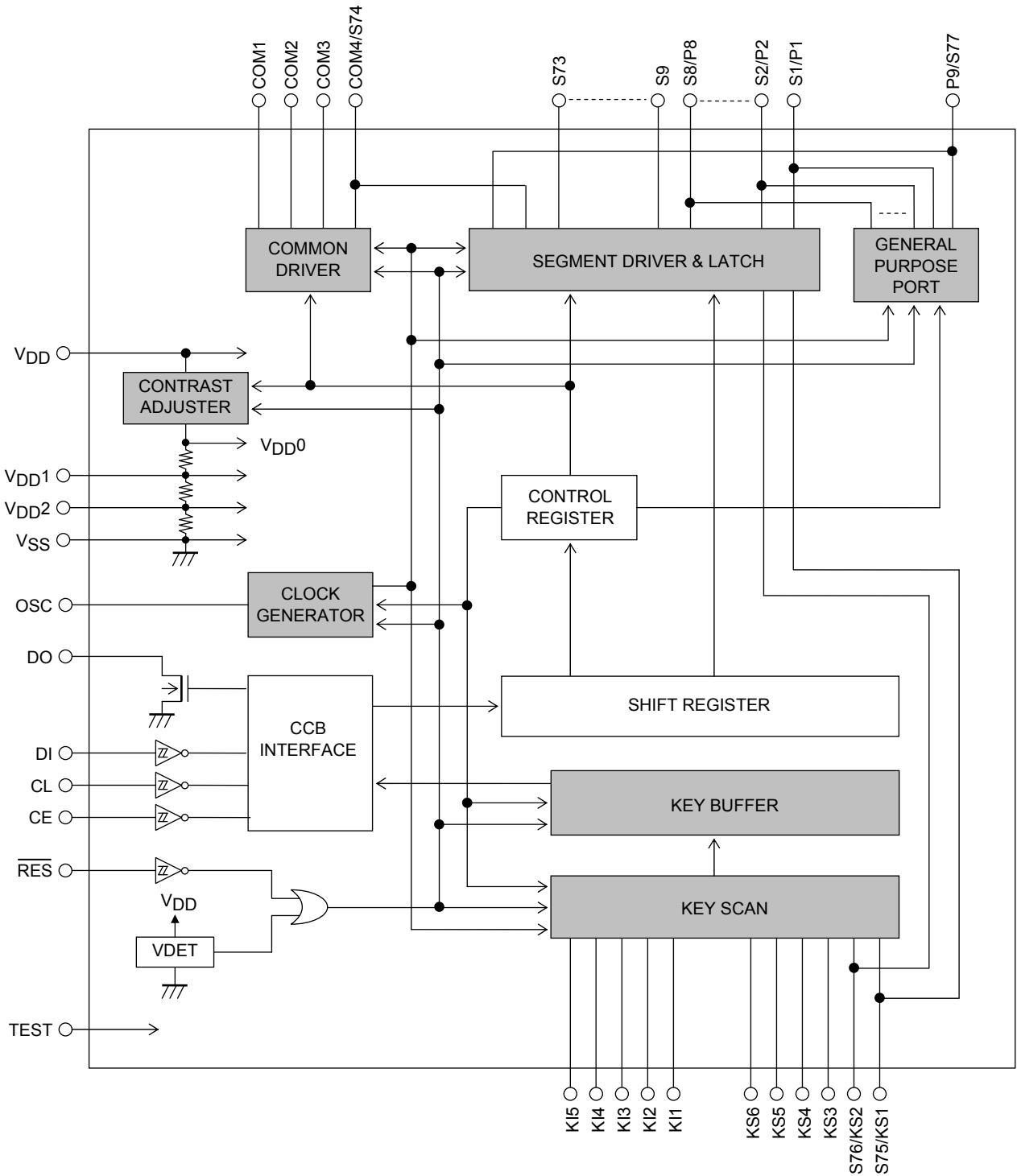

 Blocks that are reset

3. Pin states during the reset period

| Pin              | State during reset |
|------------------|--------------------|
| S1/P1 to S8/P8   | L *6               |
| S9 to S73        | L                  |
| COM1 to COM3     | L                  |
| COM4/S74         | L *7               |
| KS1/S75, KS2/S76 | L *6               |
| KS3 to KS6       | L *8               |
| P9/S77           | L *9               |
| OSC              | Z *10              |
| DO               | H *11              |

Note: \*6. These output pins are forcibly set to the segment output function and held low.

\*7. This output pin is forcibly set to the common output function and held low.

\*8. These output pins are forcibly held fixed at the low level.

\*9. This output pin is forcibly set to the general-purpose output port function and held low.

\*10. This I/O pin is forcibly set to the high-impedance state.

\*11. Since this output pin is an open-drain output, a pull-up resistor of between 1 and 10 kΩ is required. This pin remains high during the reset period even if a key data read operation is performed.

**Notes on the OSC Pin Peripheral Circuit**

1. RC oscillator operating mode (Control data bit OC = 0)

When RC oscillator operating mode is selected, an external resistor R<sub>OSC</sub> and an external capacitor C<sub>OSC</sub> must be connected between the OSC pin and GND.

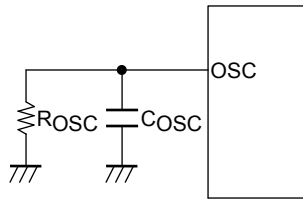

2. External clock operating mode (Control data bit OC = 1 )

When selecting the external clock operating mode, connect a current protection resistor R<sub>g</sub> (4.7 to 47 kΩ) between the OSC pin and the external clock output pin (external oscillator). Determine the value of the resistance according to the maximum allowable current value of the external clock output pin. Also make sure that the waveform of the external clock is not excessively distorted.

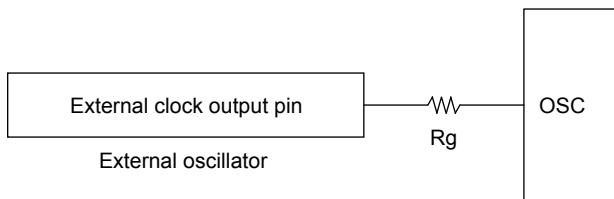

Note: Allowable current value at external clock output pin >  $\frac{V_{DD}}{R_g}$

# LC75806PTS-T

## Sample Application Circuit 1

1/4 duty, 1/3 bias

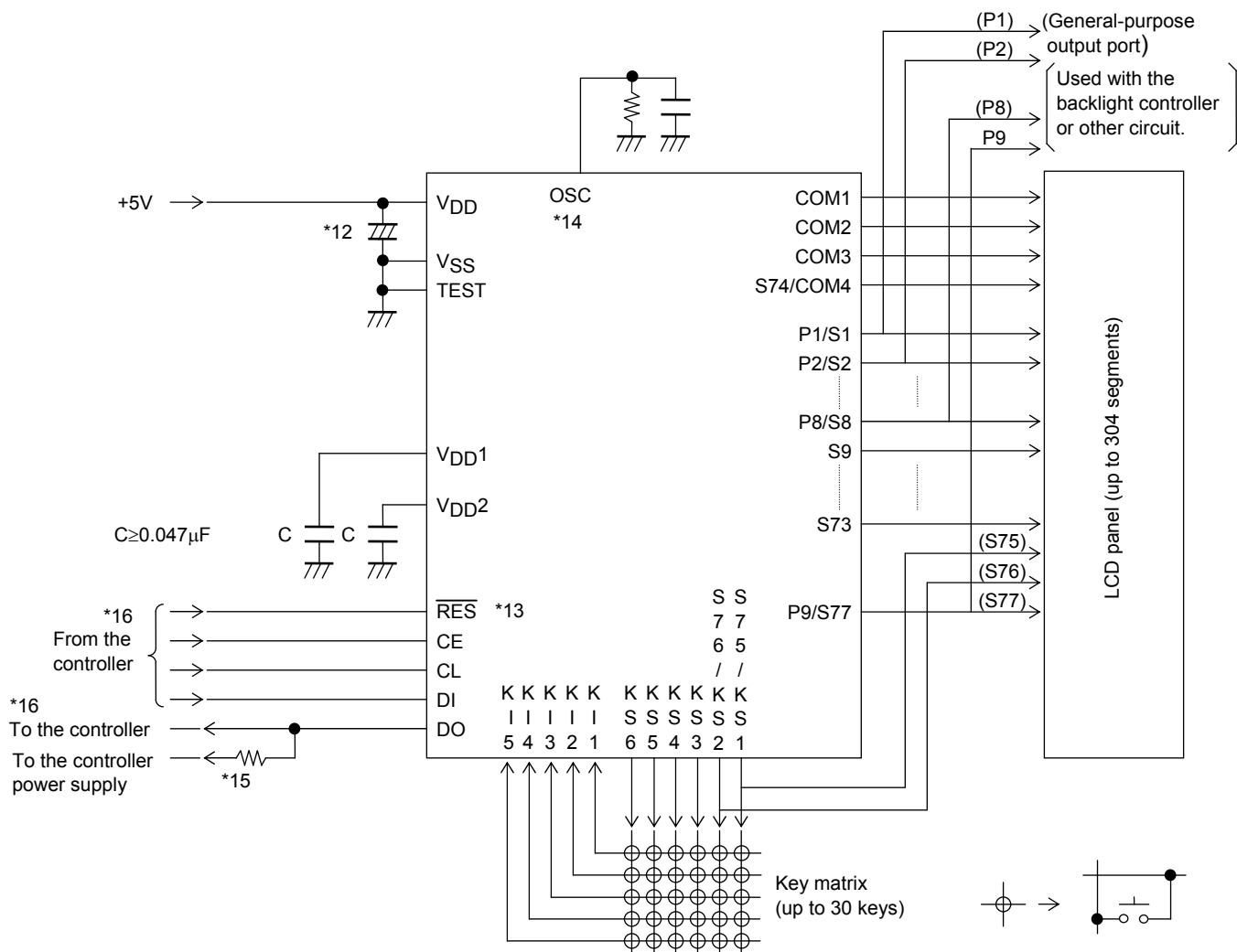

Note: \*12. Add a capacitor to the power supply line so that the power supply voltage  $V_{DD}$  rise time when power is applied and the power supply voltage  $V_{DD}$  fall time when power drops are both at least 1 ms, as the LC75806PTS-T is reset by the  $V_{DET}$ .

\*13. If the  $\overline{RES}$  pin is not used for system reset, it must be connected to the power supply  $V_{DD}$ .

\*14. When RC oscillator operating mode is used, the external resistor  $R_{OSC}$  and the external capacitor  $C_{OSC}$  must be connected between the OSC pin and GND, and when external clock operating mode is selected the current protection resistor  $R_g$  (4.7 to 47 k $\Omega$ ) must be connected between the OSC pin and the external clock output pin (external oscillator). (See the section on the OSC pin peripheral circuit.)

\*15. The DO pin, being an open-drain output, requires a pull-up resistor. Select a resistance (between 1 to 10 k $\Omega$ ) appropriate for the capacitance of the external wiring so that signal waveforms are not degraded.

\*16. The pins to be connected to the controller (CE, CL, DI, DO,  $\overline{RES}$ ) can handle 3.3 V or 5 V.

# LC75806PTS-T

## Sample Application Circuit 2

1/3 duty, 1/3 bias

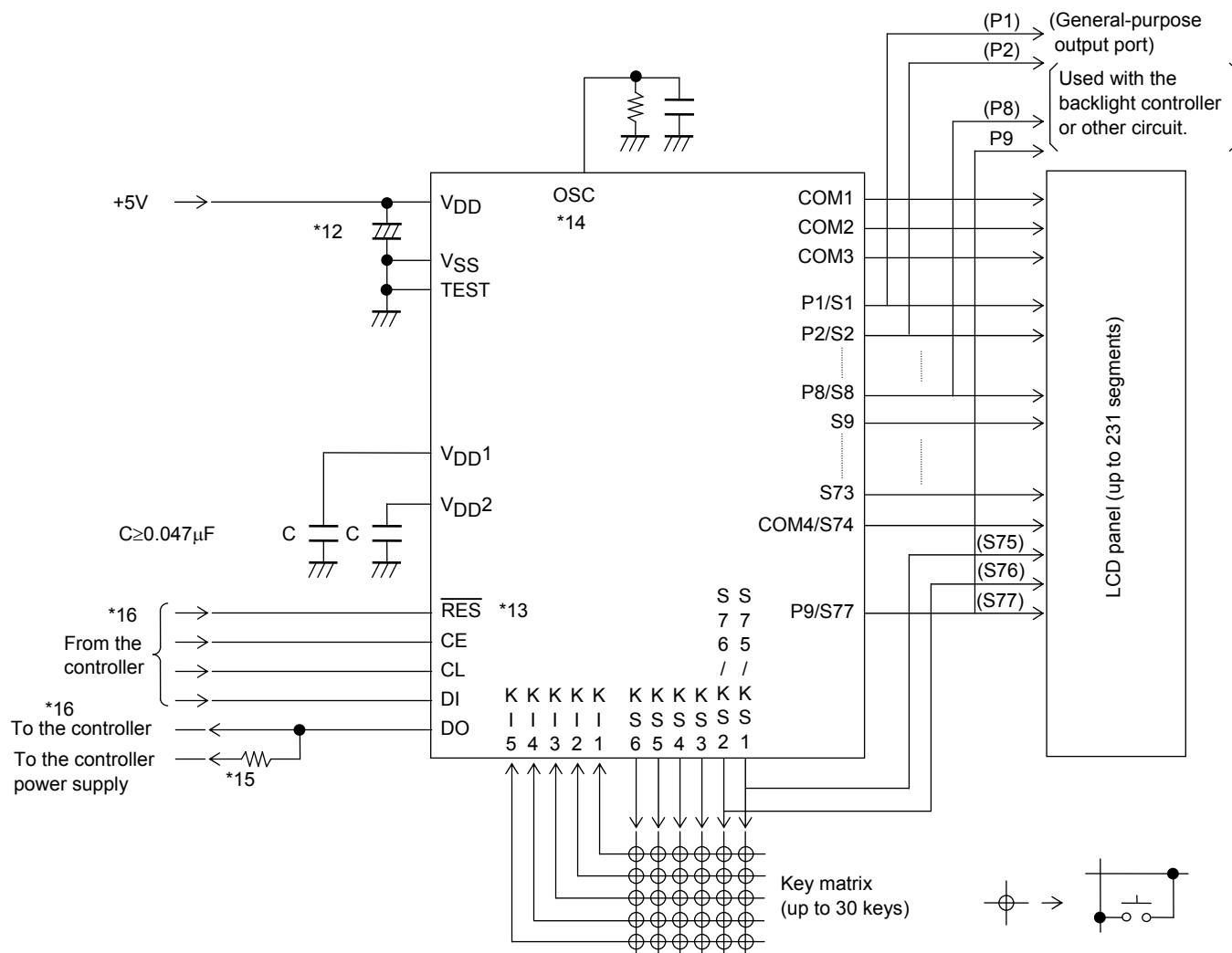

Note: \*12. Add a capacitor to the power supply line so that the power supply voltage  $V_{DD}$  rise time when power is applied and the power supply voltage  $V_{DD}$  fall time when power drops are both at least 1 ms, as the LC75806PTS-T is reset by the  $V_{DET}$ .

\*13. If the  $\overline{RES}$  pin is not used for system reset, it must be connected to the power supply  $V_{DD}$ .

\*14. When RC oscillator operating mode is used, the external resistor  $R_{OSC}$  and the external capacitor  $C_{OSC}$  must be connected between the OSC pin and GND, and when external clock operating mode is selected the current protection resistor  $R_g$  (4.7 to 47 k $\Omega$ ) must be connected between the OSC pin and the external clock output pin (external oscillator). (See the section on the OSC pin peripheral circuit.)

\*15. The DO pin, being an open-drain output, requires a pull-up resistor. Select a resistance (between 1 to 10 k $\Omega$ ) appropriate for the capacitance of the external wiring so that signal waveforms are not degraded.

\*16. The pins to be connected to the controller (CE, CL, DI, DO,  $\overline{RES}$ ) can handle 3.3 V or 5 V.

### Notes on Transferring Display Data from The Controller

When using the LC75806PTS-T in 1/4 duty, applications transfer the display data (D1 to D304) in four operations, and in 1/3 duty, they transfer the display data (D1 to D231) in three operations. In either case, applications should transfer all of the display data within 30 ms to maintain the quality of displayed image.

Notes on the Controller Key Data Read Techniques

1. Timer based key data acquisition

(1) Flowchart

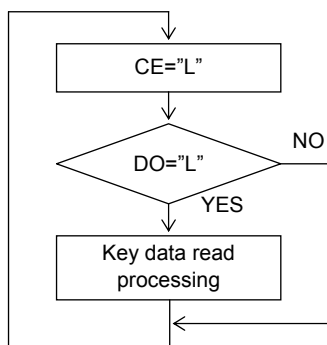

(2) Timing chart

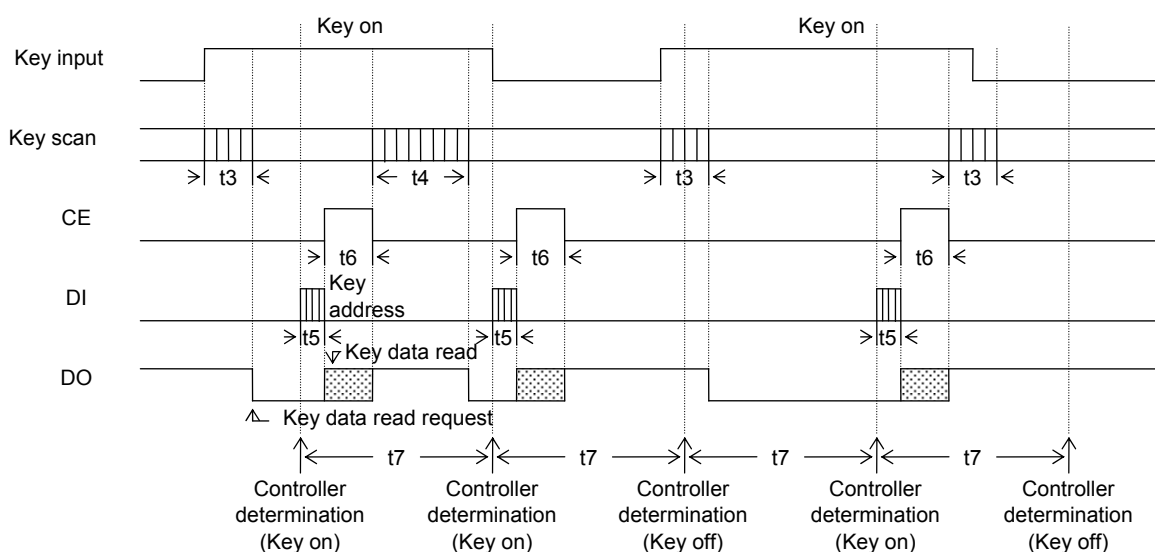

t3 ..... Key scan execution time when the key data agreed for two key scans. (615T[s])

t4 ..... Key scan execution time when the key data did not agree for two key scans and the key scan was executed again. (1230T[s])

t5 ..... Key address (43H) transfer time

t6 ..... Key data read time

$$T = \frac{1}{f_{OSC}} = \frac{1}{f_{CK}}$$

(3) Explanation

In this technique, the controller uses a timer to determine key on/off states and read the key data. The controller must check the DO state when CE is low every t7 period without fail. If DO is low, the controller recognizes that a key has been pressed and executes the key data read operation.

The period t7 in this technique must satisfy the following condition.

$$t7 > t4 + t5 + t6$$

If a key data read operation is executed when DO is high (DO does not generate a key data read request output), the read key data (KD1 to KD30) and sleep acknowledge data (SA) will be invalid.

2. Interrupt based key data acquisition

(1) Flowchart

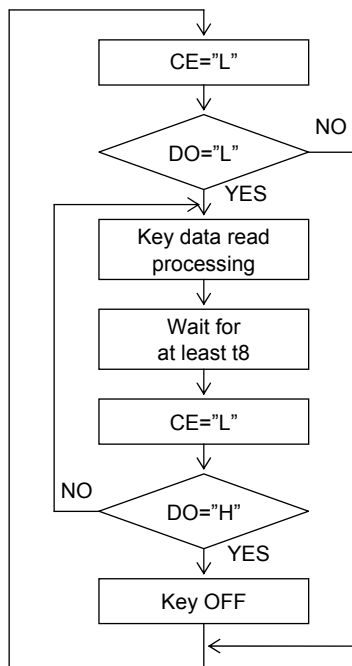

(2) Timing chart

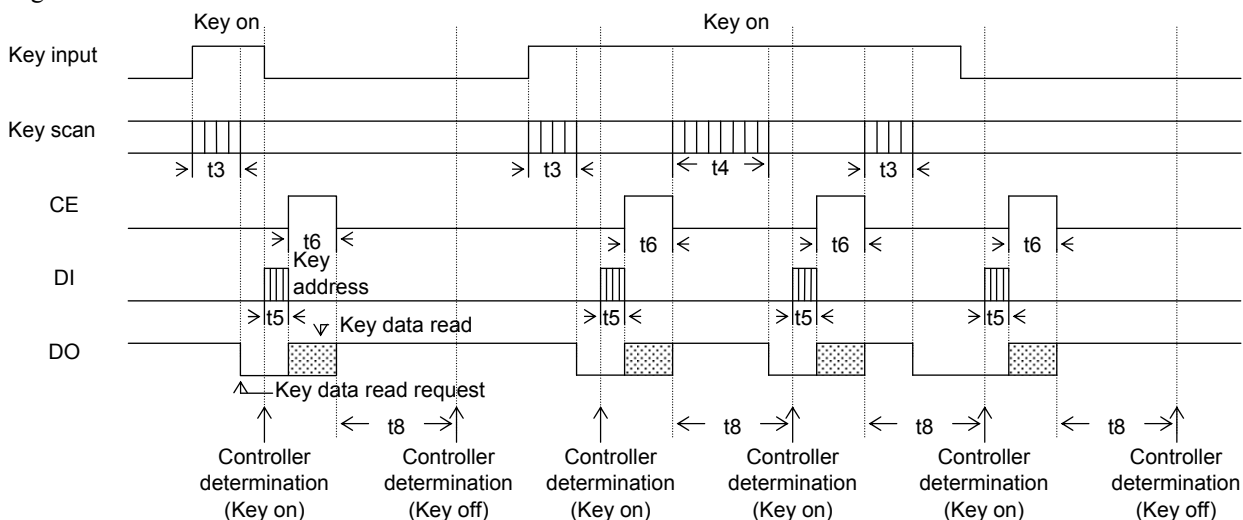

t3 ..... Key scan execution time when the key data agreed for two key scans. (615T[s])

t4 ..... Key scan execution time when the key data did not agree for two key scans and the key scan was executed again. (1230T[s])

t5 ..... Key address (43H) transfer time

t6 ..... Key data read time

$$T = \frac{1}{f_{OSC}} = \frac{1}{f_{CK}}$$

(3) Explanation

In this technique, the controller uses interrupts to determine key on/off states and read the key data.

The controller must check the DO state when CE is low. If DO is low, the controller recognizes that a key has been pressed and executes the key data read operation. After that the next key on/off determination is performed after the time t8 has elapsed by checking the DO state when CE is low and reading the key data. The period t8 in this technique must satisfy the following condition.

$$t8 > t4$$

If a key data read operation is executed when DO is high (DO does not generate a key data read request output), the read key data (KD1 to KD30) and sleep acknowledge data (SA) will be invalid.

# LC75806PTS-T

## About Data Communication Method with The Controller

### 1. About data communication method of 4 line type CCB format

The 4 line type CCB format is the data communication method of before. The LC75806PTS-T must connect to the controller as followings.

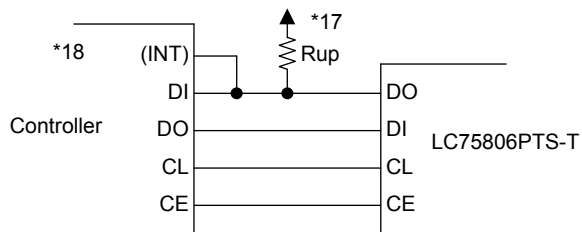

Note: \*17. Connect the pull-up resistor  $R_{up}$ . Select a resistance (between 1 to 10k $\Omega$ ) appropriate for the capacitance of the external wiring so that signal waveforms are not degraded.  
\*18. The (INT) pin is an input port for the key data read request signal (a low level on DO) detection.

### 2. About data communication method of 3 line type CCB format

The 3 line type CCB format is the data communication method that made a common use of the data input DI in the data output DO. The LC75806PTS-T must connect to the controller as followings.

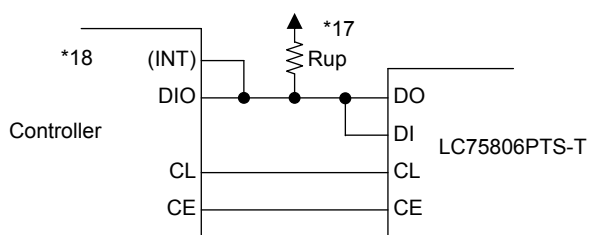

Note: \*17. Connect the pull-up resistor  $R_{up}$ . Select a resistance (between 1 to 10k $\Omega$ ) appropriate for the capacitance of the external wiring so that signal waveforms are not degraded.  
\*18. The (INT) pin is an input port for the key data read request signal (a low level on DO) detection.

In this case, Applications must transfer the data communication start command before the serial data input (CCB address "42H", display data and control data transfer) or serial data output (CCB address "43H" transfer, key data read) to avoid the collision of the data input signal DI and the data output signal DO.

Then applications must transfer the data communication stop command when the controller wants to detect the key data read request signal (a low level on DO) during a movement stop of the serial data input and the serial data output.

#### <1> Data communication start command

(1) When CL is stopped at the low level

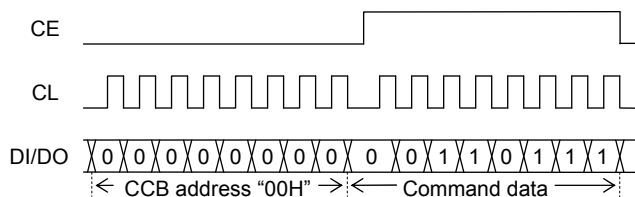

(2) When CL is stopped at the high level

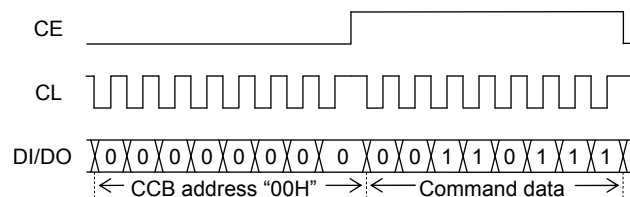

#### <2> Data communication stop command

(1) When CL is stopped at the low level

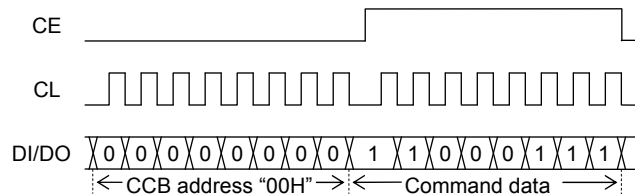

(2) When CL is stopped at the high level

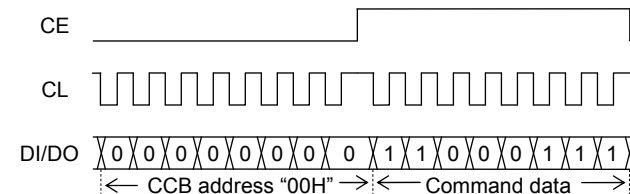

**Data Communication Flowchart of 4 Line Type or 3 Line Type CCB Format**

1. Flowchart of the initial setting when power is turned on.

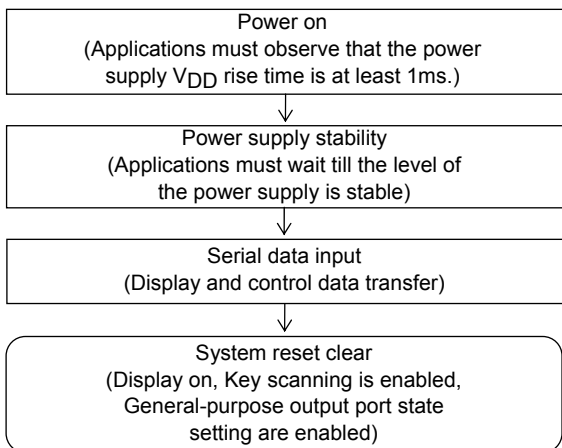

Note: The flowchart of initial setting when power is turned on is same regardless of the 4 line type or 3 line type CCB format. Take explanation about "system reset" into account.

2. Flowchart of the serial data input

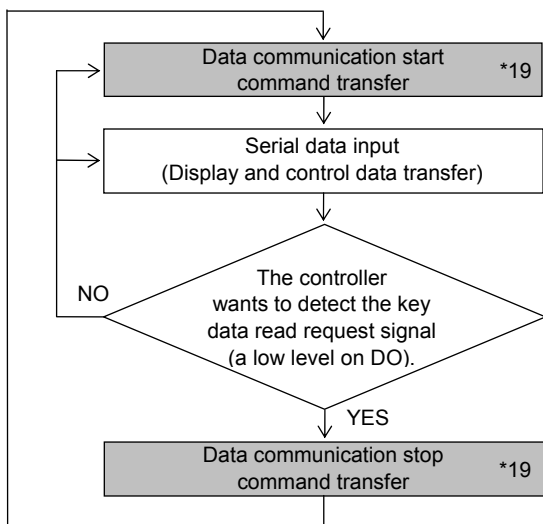

Note: \*19. In the case of the 4 line type CCB format, the transfers of data communication start command and data communication stop command are unnecessary, and, in the case of the 3 line type CCB format, these transfers are necessary.

3. Flowchart of the serial data output

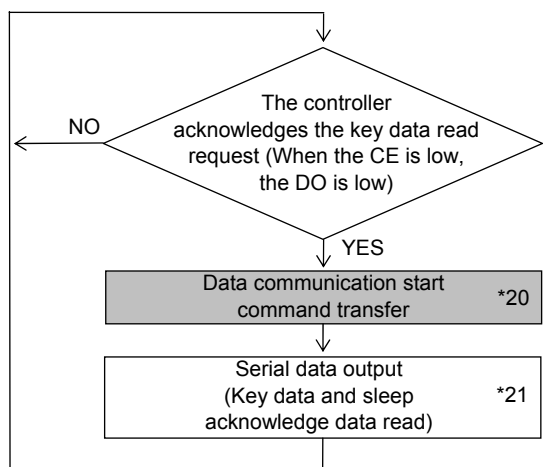

Note: \*20. In the case of the 4 line type CCB format, the transfer of data communication start command is unnecessary, and, in the case of the 3 line type CCB format, the transfer is necessary.

\*21. Because the serial data output has the role of the data communication stop command, it is not necessary to transfer the data communication stop command some other time.



Timing Chart of 4 Line Type and 3 Line Type CCB Format

1. Timing chart of 4 line type CCB format

<Example 1>

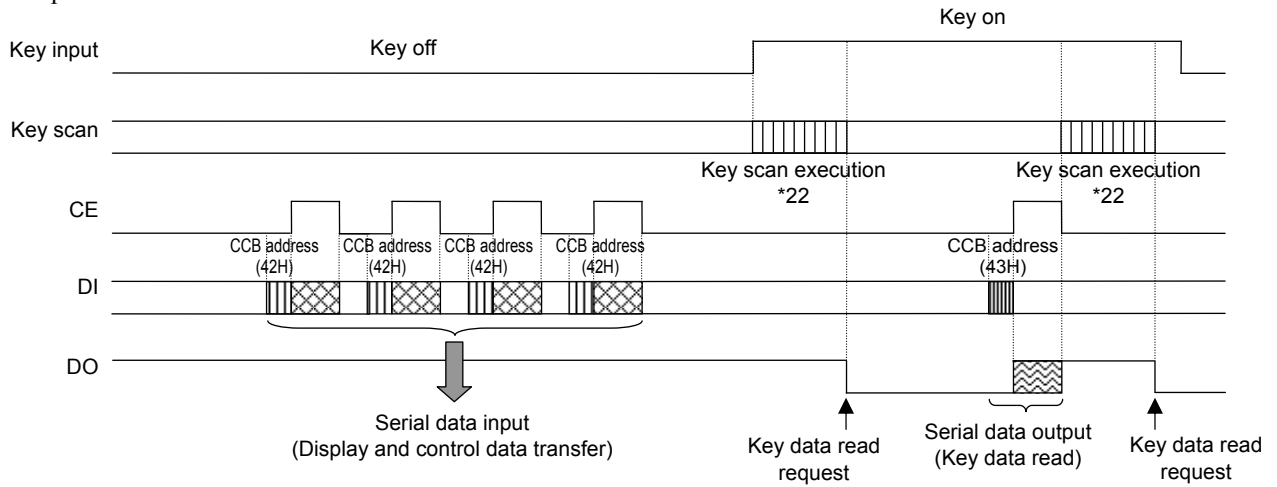

<Example 2>

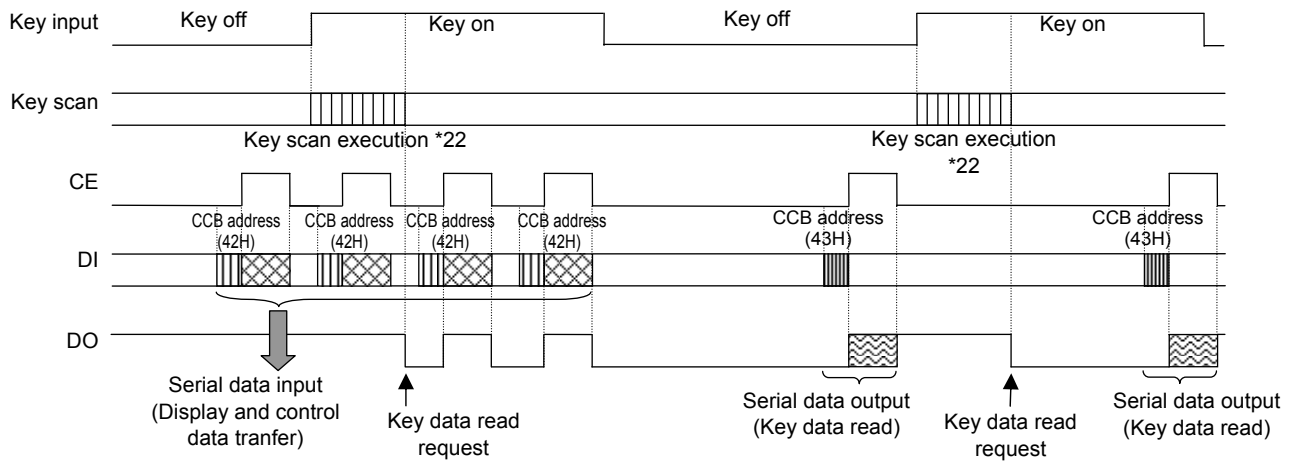

<Example 3>

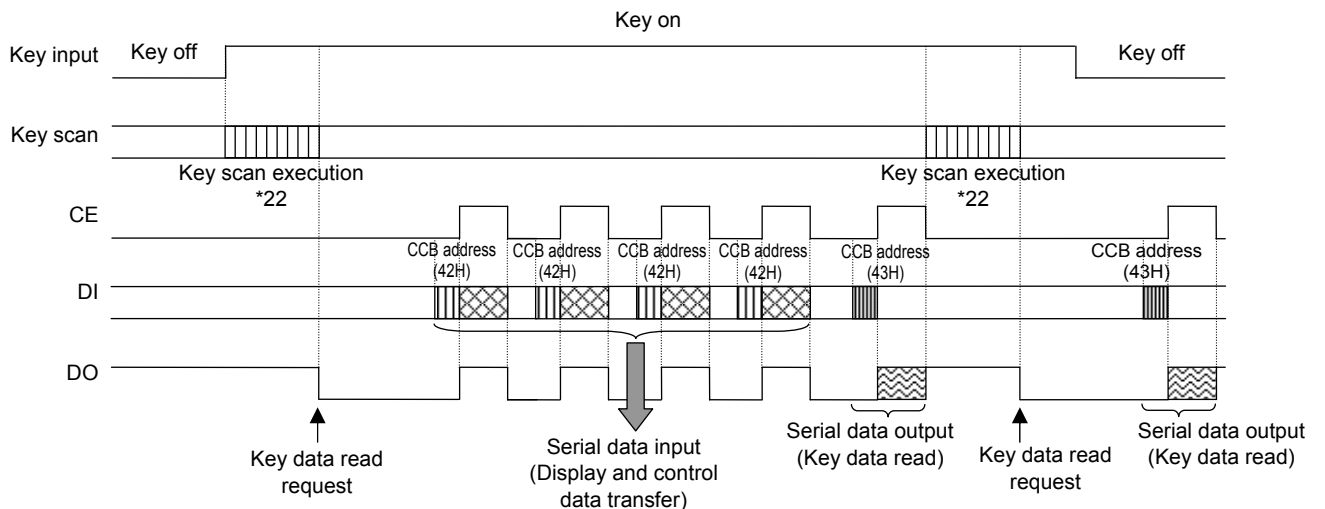

Note: \*22. When the key data agrees for two key scans, the key scan execution time is 615T[s].

And, when the key data does not agree for two key scans and the key scan is executed again, the key scan execution time is 1230T[s].

$$T = \frac{1}{f_{OSC}} = \frac{1}{f_{CK}}$$

2. Timing chart of 3 line type CCB format

<Example 1>

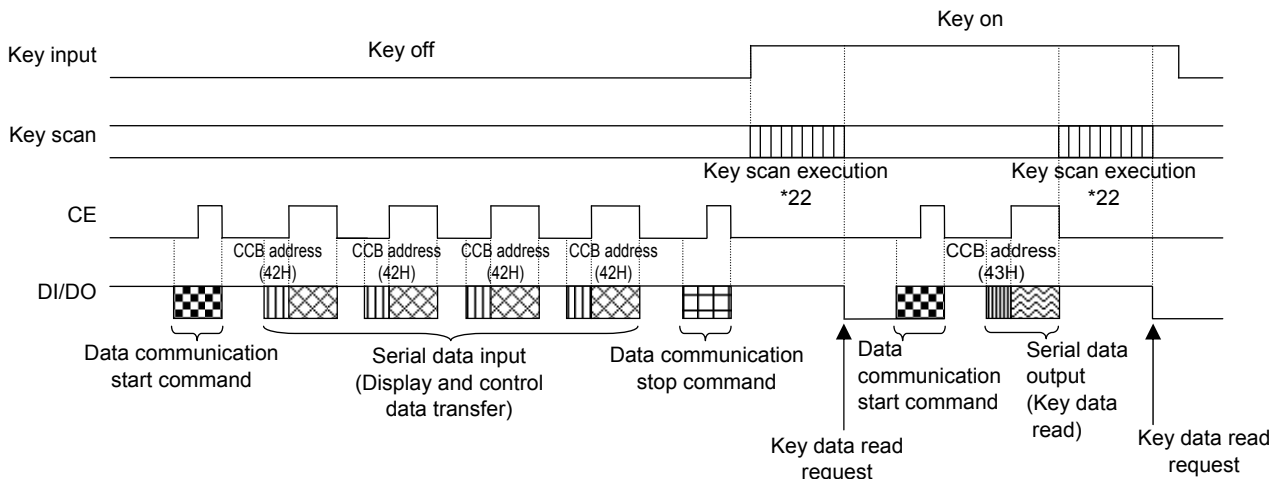

<Example 2>

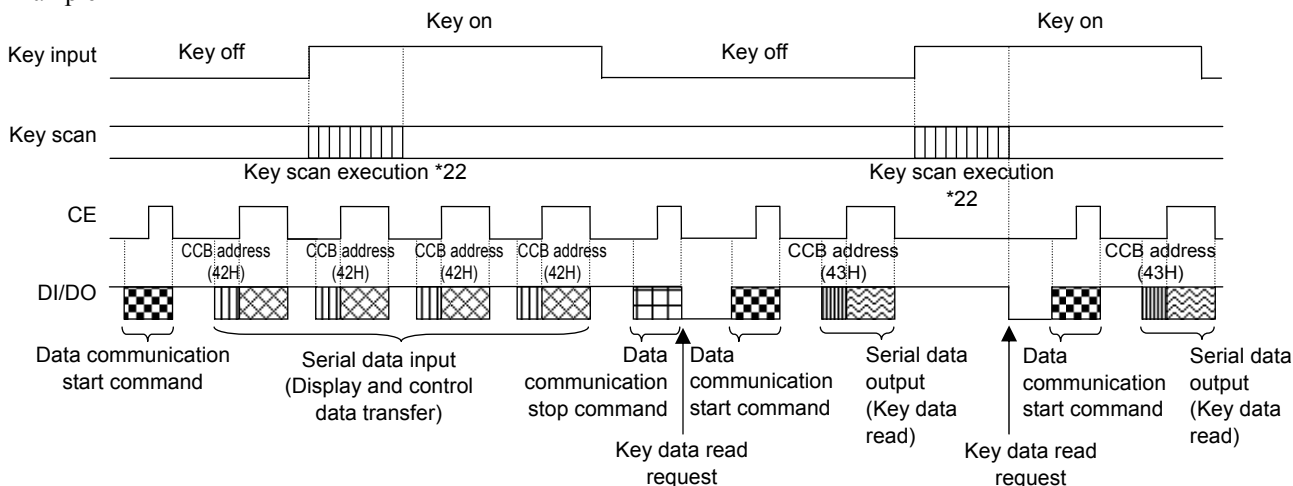

<Example 3>

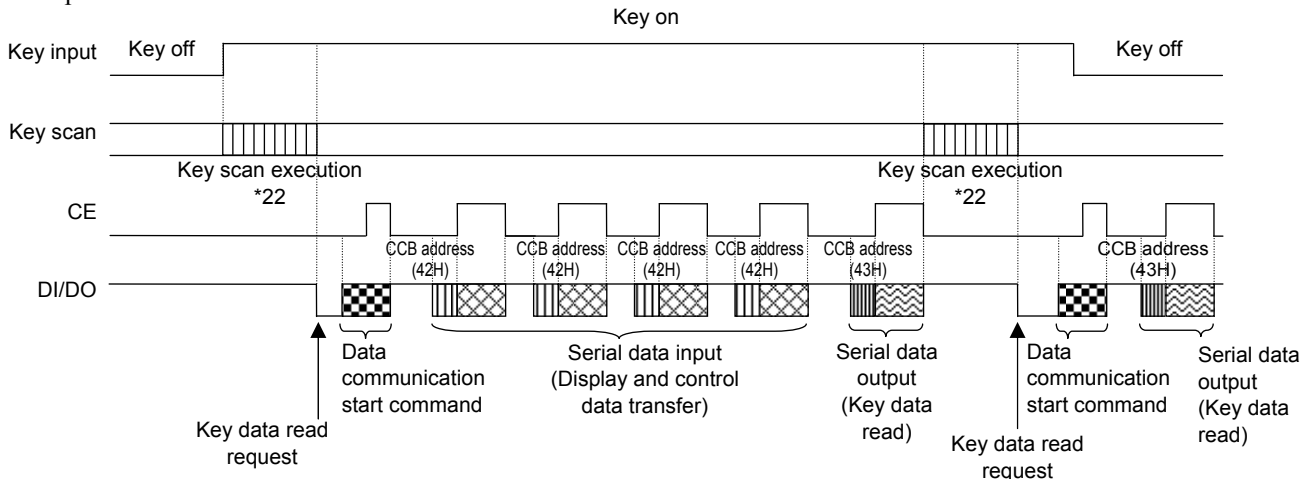

Note: \*22. When the key data agrees for two key scans, the key scan execution time is 615T[s].

And, when the key data does not agree for two key scans and the key scan is executed again, the key scan execution time is 1230T[s].

$$T = \frac{1}{f_{OSC}} = \frac{1}{f_{CK}}$$

# LC75806PTS-T

## Package Dimensions

unit : mm

TQFP100 14x14 / TQFP100

CASE 932AY

ISSUE A

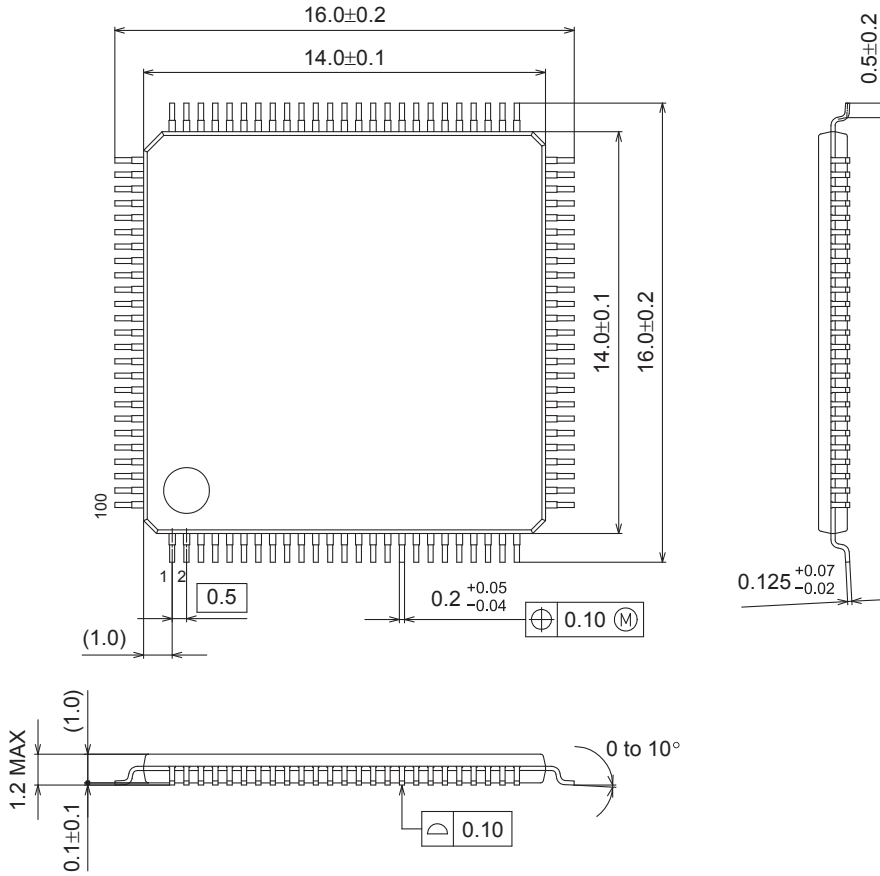

### SOLDERING FOOTPRINT\*

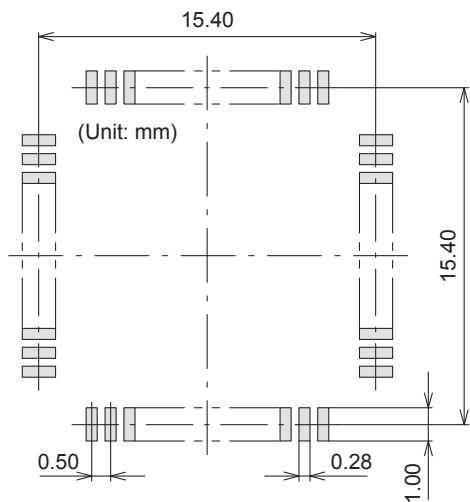

### GENERIC MARKING DIAGRAM\*

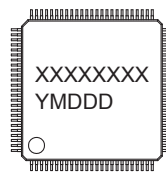

XXXXX = Specific Device Code  
 Y = Year  
 M = Month  
 DDD = Additional Traceability Data

\*This information is generic. Please refer to device data sheet for actual part marking. Pb-Free indicator, "G" or microdot "■", may or may not be present.

NOTE: The measurements are not to guarantee but for reference only.

\*For additional information on our Pb-Free strategy and soldering details, please download the ON Semiconductor Soldering and Mounting Techniques Reference Manual, SOLDERRM/D.

# LC75806PTS-T

## ORDERING INFORMATION

| Device         | Package   | Shipping (Qty / Packing) |
|----------------|---|--------------------------|
| LC75806PTS-T-H | TQFP100 14x14 / TQFP100<br>(Pb-Free / Halogen Free) | 450 / Tray JEDEC         |

ON Semiconductor and the ON Semiconductor logo are trademarks of Semiconductor Components Industries, LLC dba ON Semiconductor or its subsidiaries in the United States and/or other countries. ON Semiconductor owns the rights to a number of patents, trademarks, copyrights, trade secrets, and other intellectual property. A listing of ON Semiconductor's product/patent coverage may be accessed at [www.onsemi.com/site/pdf/Patent-Marking.pdf](http://www.onsemi.com/site/pdf/Patent-Marking.pdf). ON Semiconductor reserves the right to make changes without further notice to any products herein. ON Semiconductor makes no warranty, representation or guarantee regarding the suitability of its products for any particular purpose, nor does ON Semiconductor assume any liability arising out of the application or use of any product or circuit, and specifically disclaims any and all liability, including without limitation special, consequential or incidental damages. Buyer is responsible for its products and applications using ON Semiconductor products, including compliance with all laws, regulations and safety requirements or standards, regardless of any support or applications information provided by ON Semiconductor. "Typical" parameters which may be provided in ON Semiconductor data sheets and/or specifications can and do vary in different applications and actual performance may vary over time. All operating parameters, including "Typicals" must be validated for each customer application by customer's technical experts. ON Semiconductor does not convey any license under its patent rights nor the rights of others. ON Semiconductor products are not designed, intended, or authorized for use as a critical component in life support systems or any FDA Class 3 medical devices or medical devices with a same or similar classification in a foreign jurisdiction or any devices intended for implantation in the human body. Should Buyer purchase or use ON Semiconductor products for any such unintended or unauthorized application, Buyer shall indemnify and hold ON Semiconductor and its officers, employees, subsidiaries, affiliates, and distributors harmless against all claims, costs, damages, and expenses, and reasonable attorney fees arising out of, directly or indirectly, any claim of personal injury or death associated with such unintended or unauthorized use, even if such claim alleges that ON Semiconductor was negligent regarding the design or manufacture of the part. ON Semiconductor is an Equal Opportunity/Affirmative Action Employer. This literature is subject to all applicable copyright laws and is not for resale in any manner.

Компания «Океан Электроники» предлагает заключение долгосрочных отношений при поставках импортных электронных компонентов на взаимовыгодных условиях!

Наши преимущества:

- Поставка оригинальных импортных электронных компонентов напрямую с производств Америки, Европы и Азии, а так же с крупнейших складов мира;
- Широкая линейка поставок активных и пассивных импортных электронных компонентов (более 30 млн. наименований);
- Поставка сложных, дефицитных, либо снятых с производства позиций;
- Оперативные сроки поставки под заказ (от 5 рабочих дней);
- Экспресс доставка в любую точку России;
- Помощь Конструкторского Отдела и консультации квалифицированных инженеров;
- Техническая поддержка проекта, помощь в подборе аналогов, поставка прототипов;
- Поставка электронных компонентов под контролем ВП;
- Система менеджмента качества сертифицирована по Международному стандарту ISO 9001;
- При необходимости вся продукция военного и аэрокосмического назначения проходит испытания и сертификацию в лаборатории (по согласованию с заказчиком);
- Поставка специализированных компонентов военного и аэрокосмического уровня качества (Xilinx, Altera, Analog Devices, Intersil, Interpoint, Microsemi, Actel, Aeroflex, Peregrine, VPT, Syfer, Eurofarad, Texas Instruments, MS Kennedy, Miteq, Cobham, E2V, MA-COM, Hittite, Mini-Circuits, General Dynamics и др.);

Компания «Океан Электроники» является официальным дистрибьютором и эксклюзивным представителем в России одного из крупнейших производителей разъемов военного и аэрокосмического назначения «JONHON», а так же официальным дистрибьютором и эксклюзивным представителем в России производителя высокотехнологичных и надежных решений для передачи СВЧ сигналов «FORSTAR».



## JONHON

«JONHON» (основан в 1970 г.)

Разъемы специального, военного и аэрокосмического назначения:

(Применяются в военной, авиационной, аэрокосмической, морской, железнодорожной, горно- и нефтедобывающей отраслях промышленности)

«FORSTAR» (основан в 1998 г.)

ВЧ соединители, коаксиальные кабели, кабельные сборки и микроволновые компоненты:

(Применяются в телекоммуникациях гражданского и специального назначения, в средствах связи, РЛС, а так же военной, авиационной и аэрокосмической отраслях промышленности).



Телефон: 8 (812) 309-75-97 (многоканальный)

Факс: 8 (812) 320-03-32

Электронная почта: [ocean@oceanchips.ru](mailto:ocean@oceanchips.ru)

Web: <http://oceanchips.ru/>

Адрес: 198099, г. Санкт-Петербург, ул. Калинина, д. 2, корп. 4, лит. А