



Accurax G5-Linear Servo system

with Analogue/Pulse control

Model:

R88D-KT□□□-L Servo Drives

R88L-EC-GW-□□-□□□ Linear Servo Motors

R88L-EC-FW-□□-□□□ Linear Servo Motors

USER'S MANUAL



OMRON

Introduction

Thank you for purchasing the Accurax G5-Linear. This user's manual explains how to install and wire the Accurax G5-Linear, set parameters needed to operate the G5, and remedies to be taken and inspection methods to be used if problems occur.

Intended Readers

This manual is intended for the following individuals.

Those having electrical knowledge (certified electricians or individuals having equivalent or more knowledge) and also being qualified for one of the following:

- ♦ Those in charge of introducing FA equipment
- ♦ Those designing FA systems
- ♦ Those managing FA sites

Notes

This manual contains the information you need to know to correctly use the Accurax G5-Linear and peripheral equipment.

Before using the Accurax G5-Linear, read through this manual and gain a full understanding of the information provided herein.

After you finished reading the manual, keep it in a convenient place so that the manual can be referenced at any time.

Make sure this manual will also get to the end-user.

Items Requiring Acknowledgment

1. Terms of Warranty

(1) Warranty period

The warranty period of this product is 1 year after its purchase or delivery to the specified location.

(2) Scope of warranty

If the product fails during the above warranty period due to design, material or workmanship, we will provide a replacement unit or repair the faulty product free of charge at the location where you purchased the product.

Take note, however, that the following failures are excluded from the scope of warranty.

- a) Failure due to use or handling of the product in any condition or environment not specified in the catalog, operation manual, etc.
- b) Failure not caused by this product
- c) Failure caused by any modification or repair not carried out by OMRON
- d) Failure caused by any use not intended for this product
- e) Failure that could not be predicted with the level of science and technology available when the product was shipped from OMRON
- f) Failure caused by a natural disaster or any other reason for which OMRON is not held responsible

Take note that this warranty applies to the product itself, and losses induced by a failure of the product are excluded from the scope of warranty.

2. Limited Liability

- (1) OMRON shall not assume any responsibility whatsoever for any special damage, indirect damage or passive damage arising from this product.
- (2) OMRON shall not assume any responsibility for programming done by individuals not belonging to OMRON, if the product is programmable, or outcomes of such programming.

3. Conditions for Intended Application

- (1) If this product is combined with other product, the customer must check the standards and regulations applicable to such combination. The customer must also check the compatibility of this product with any system, machinery or device used by the customer. If the above actions are not taken, OMRON shall not assume any responsibility regarding the compatibility of this product.
- (2) If the product is used in the following applications, consult your OMRON sales representative to check the necessary items according to the specification sheet, etc. Also make sure the product is used within the specified ratings and performance ranges with an ample margin and implement safety measures, such as designing a safety circuit, to minimize danger should the product fail.
 - a) Used in any outdoor application, application subject to potential chemical contamination or electrical interference, or in any condition or environment not specified in the catalog, operation manual, etc.
 - b) Nuclear power control equipment, incineration equipment, railway, aircraft and vehicle equipment, medical machinery, entertainment machinery, safety system or any other device controlled by an administrative agency or industry regulation
 - c) System, machinery or device that may threaten human life or property
 - d) Gas, water or electricity supply system, system operated continuously for 24 hours or any other equipment requiring high reliability
 - e) Any other application where a high level of safety corresponding to a) to d) above is required
- (3) If the customer wishes to use this product in any application that may threaten human life or property, be sure to confirm beforehand that the entire system is designed in

such a way to notify dangers or ensure the necessary level of safety via design redundancy, and that the product is wired and installed appropriately in the system according to the intended application.

- (4) Sample applications explained in the catalog, etc. are provided for reference purposes only. When adopting any of these samples, check the function and safety of each equipment or device.
- (5) Understand all prohibited items and notes on use provided herein, so that this product will be used correctly and that customers or third parties will not suffer unexpected losses.

4. Specification Change

The product specifications and accessories explained in the catalog, operation manual, etc. are subject to change, if necessary, for the reasons of improvement, etc. Contact your OMRON sales representative to check the actual specifications of this product.

5. Scope of Service



The price of this product excludes costs of service such as dispatching engineers. If you have any request regarding service, consult your OMRON sales representative.

Safety Precautions Document

- So that the Accurax G5-Linear Servo Motor and Servo Drive and peripheral equipment are used safely and correctly, be sure to peruse this Safety Precautions document section and the main text before using the product in order to learn all items you should know regarding the equipment as well as all safety information and precautions.
- Make an arrangement so that this manual also gets to the end-user of this product.
- After reading this manual, keep it with you at all times.

Explanation of Display

- The precautions explained in this section describe important information regarding safety and must be followed without fail.
- The display of precautions used in this manual and their meanings are explained below.

 <b style="font-size: 1.5em;">Danger	When an incorrect handling can lead to a dangerous situation, which may result in death or serious injury Or, when a serious property damage may occur
 <b style="font-size: 1.5em;">Caution	When an incorrect handling can lead to a dangerous situation, which may result in a minor or moderate injury, and when only a property damage may occur



Even those items denoted by the caution symbol may lead to a serious outcome depending on the situation. Accordingly, be sure to observe all safety precautions.

This symbol indicates an item you should perform or avoid in order to use the product safely.

This symbol indicates an item you should perform or avoid in order to prevent inoperative, malfunction or any negative effect on performance or function.















This symbol indicates an item that helps deepen your understanding of the product or other useful tip.

Explanation of Symbols

Example of symbols	
	<p>△ This symbol indicates danger and caution.</p> <p>The specific instruction is described using an illustration or text inside or near △. The symbol shown to the left indicates "beware of electric shock".</p>
	<p>⊘ This symbol indicates a prohibited item (item you must not do).</p> <p>The specific instruction is described using an illustration or text inside or near ⊘. The symbol shown to the left indicates "disassembly prohibited".</p>
	<p>● This symbol indicates a compulsory item (item that must be done).</p> <p>The specific instruction is described using an illustration or text inside or near ●. The symbol shown to the left indicates "grounding required".</p>

For Safe Use of This Product

- Illustrations contained in this manual sometimes depict conditions without covers and safety shields for the purpose of showing the details. When using this product, be sure to install the covers and shields as specified and use the product according to this manual.
- If the product has been stored for an extended period of time, contact your OMRON sales representative.

 Danger	
	Be sure to ground the frame ground terminals of the drive and motor to 100 Ω or less. Electric shock may result.
	Never touch the parts inside the drive. Electric shock may result.
	While the power is supplied, do not remove the front cover, terminal covers, cables and options. Electric shock may result.
	Installation, operation and maintenance or inspection by unauthorized personnel is prohibited. Electric shock or injury may result.
	Before carrying out wiring or inspection, turn OFF the power supply and wait for at least 15 minutes. Electric shock may result.
	Do not damage, pull, stress strongly or pinch the cables or place heavy articles on them. Electric shock, stopping of product operation or burn damage may result.
	Never touch the moving part of the motor during operation. Injury may result.
	Never modify the product. Injury or equipment damage may result.
	Install a stopping device on the machine side to ensure safety. Injury may result.
	Install an immediate stop device externally to the machine so that the operation can be stopped and the power supply cut off immediately. Injury may result.
	When the power is restored after a momentary power interruption, the machine may restart suddenly. Never come close to the machine. * Implement remedies to ensure safety of people nearby even when the machine is restarted. Injury may result.
	After an earthquake, be sure to conduct safety checks. Electric shock, injury or fire may result.
	Never drive the motor using an external drive source. Fire may result.



Danger



Do not place flammable materials near the motor, drive or Regeneration Resistor.
Fire may result.



Install the motor, drive and Regeneration Resistor to non-flammable materials such as metals.
Fire may result.



When you perform a system configuration using the safety function, be sure to fully understand the relevant safety standards and the descriptions in the operation manual, and apply them to the system design.
Injury or damage may result.



Do not use the cable when it is laying in oil or water.
Electric shock, injury or fire may result.



Never connect a commercial power supply directly to the motor.
Fire or failure may result.



Do not perform wiring or any operation with wet hands.
Electric shock, injury or fire may result.



Do not touch the motor with bare hands or place them inside the motor movable zone.
Injury may result.



Install a stopping device on the machine to ensure safety.
The Linear Servomotor may not be maintained to be stopped when the Linear Servomotor is uncontrolled.
Or, injury or equipment damage may result.



Use the motor and drive in the specified combination.
Fire or equipment damage may result.



Caution



Do not store or install the product in the following environment:
Location subject to direct sunlight
Location where the ambient temperature exceeds the specified level
Location where the relative humidity exceeds the specified level
Location subject to condensation due to the rapid temperature change
Location subject to corrosive or flammable gases
Location subject to higher levels of dust, salt content or iron dust
Location subject to splashes of water, oil, chemicals, etc.
Location where the product may receive vibration or impact directly
Installing or storing the product in these locations may result in fire, electric shock or equipment damage.



The drive radiator, Regeneration Resistor, motor, etc. may become hot while the power is supplied or remain hot for a while even after the power supply is cut off. Never touch these components.
A burn injury may result.

Storage and Transportation



Caution



When transporting the product, do not hold it by the cables.
Injury or failure may result.



Do not overload the products. (Follow the instruction on the product label.)
Injury or failure may result.



Do not place the linear-magnet close to the motor coil or other magnetic object that may be attracted.
Damage or injury may result.

















Magnetic sensitive objects like banking cards or other magnetic information carriers may be damaged if they are brought within 10cm of the magnet plates.

Installation and wiring



Caution

-  Do not step on the product or place heavy articles on it.
Injury may result.
-  Do not block the intake or exhaust openings. Do not allow foreign objects to enter the product.
Fire may result.
-  Be sure to observe the mounting direction.
Failure may result.
-  Provide the specified clearance between the drive and the inner surface of the control panel or other equipment.
Fire or failure may result.
-  Do not apply strong impact on the motor or drive.
Failure may result.
-  Wire the cables correctly and securely.
Runaway motor, injury or failure may result.
-  Securely tighten the unit mounting screws, terminal block screws and cable screws.
Failure may result.
-  Use crimp terminals for wiring.
If simple twisted wires are connected directly to the protective ground terminal, fire may result.
-  Only use the power supply voltage specified in this manual.
Burn damage may result.
-  In locations where the power supply infrastructure is poor, make sure the rated voltage can be supplied.
Equipment damage may result.
-  Provide safety measures, such as a breaker, to protect against short circuiting of external wiring.
Fire may result.
-  If the product is used in the following locations, provide sufficient shielding measures.
Location where noise generates due to static electricity, etc.
Location where a strong electric or magnetic field generates
Location where exposure to radioactivity may occur
Location where power supply lines are running nearby
Using the product in these locations may result in equipment damage.
-  Connect an immediate stop relay in series with the brake control relay.
Injury or failure may result.
-  When connecting the battery, make sure the correct polarity is connected.
Battery damage or explosion may result.
-  The magnet plates show large attraction force on all soft magnetic objects such as iron.
These forces cannot be controlled by hand.
They may cause serious jamming danger.



Do not bring any soft magnetic objects (iron) nearer than 10cm of the magnetic side of the magnet plates.



Be sure that the magnetic plates are fixed into your machine before removing the magnetic field neutralizing protection plates.



Put the magnetic field neutralizing protection plates on the magnetic plates again before dismounting them.

Operation and Adjustment



Caution



Conduct a test operation after confirming that the equipment is not affected. Equipment damage may result.



Before operating the product in an actual environment, check if it operates correctly based on the parameters you have set. Equipment damage may result.



Never adjust or set parameters to extreme values, as it will make the operation unstable. Injury may result.



Separate the motor from the mechanical load and check its operation. Injury may result.



If an alarm generated, remove the cause of the alarm and ensure safety, and then reset the alarm and restart the operation. Injury may result.



Do not operate the Linear Servo Motor when an excessive load mass is installed. Failure may result.



Install proper limit switches to prevent unexpected runaway of the motor. Injury or damage may result.



If the drive fails, cut off the power supply to the drive on the power supply side. Fire may result.



Do not turn ON and OFF the main drive power supply frequently. Failure may result.

Maintenance and Inspection



Caution



After replacing the unit, transfer to the new unit all data needed to resume operation, before restarting the operation.
Equipment damage may result.



Never repair the product by disassembling it.
Electric shock or injury may result.



Be sure to turn OFF the power supply when the unit is not going to be used for a prolonged period of time.
Injury may result.



Before carrying out checks or doing any maintenance, clear the system by disconnecting the voltage.
Be sure that there is no possibility of accidental connections.
Electric shock, injury or fire may result.

Location of Warning Label

This product bears a warning label at the following location to provide handling warnings. When handling the product, be sure to observe the instructions provided on this label.

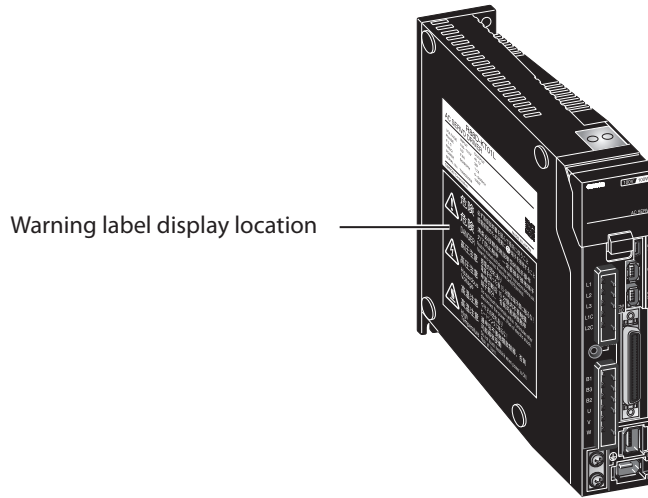

(R88D-KT02H-L)

Instructions on Warning Label

	<p>危険 必ず取扱説明書を読んで指示に従うこと 感電保護のため確実にⓍ端子を接地すること</p> <p>危险 请务必按照使用说明书的指示操作 为了防止触电，一定要接好接地端子</p> <p>DANGER Read the manual and follow the safety instructions before use. Never fail to connect Protective Earth(PE) terminal.</p>
	<p>高压注意 感電の恐れあり 電源を切った後15分間は端子部に触るな!</p> <p>高压注意 电源切断后15分钟内不要触摸 端子部分，否则可能导致触电</p> <p>Hazardous Voltage Do not touch terminals within 15 minutes after disconnect the power. Risk of electric shock.</p>
	<p>高温注意 やけどの恐れあり ヒートシンクに触るな!</p> <p>高温注意 通电后不要触摸散热器，否则 可能导致受伤</p> <p>High Temperature Do not touch heatsink when power is ON. Risk of burn.</p>

Disposal

- ◆ When disposing of the battery, insulate it using tape, etc. and dispose of it by following the applicable ordinance of your local government.
- ◆ Dispose of the product as an industrial waste.

Items to Check after Unpacking

After unpacking, check the following items.

- ♦ Is this the model you ordered?
- ♦ Is there any damage sustained during shipment?

Accessories of This Product

Safety Precautions document x 1 copy

- ♦ Connectors, mounting screws, etc. other than those in the table below are not supplied. They must be prepared by the customer.
- ♦ If any item is missing or a problem is found such as Servo Drive damage, contact the OMRON dealer or sales office where you purchased your product.

Specifications		Main power supply connector	Control power supply connector	Motor connector	Regeneration Resistor connector	Open software	Safety bypass connector
Single-phase 100 VAC	100 W	Included					
	200 W						
	400 W						
Single-phase/3-phase 200 VAC	200 W						
	400 W						
	750 W						
	1 kW						
3-phase 200 VAC	1.5 kW						
	2 kW						
3-phase 400 VAC	600 W						
	1 kW						
	1.5 kW						
	2 kW						
	3 kW						
	5 kW						Included

Manual Revision History

The manual revision symbol is an alphabet appended at the end of the manual number found in the bottom left-hand corner of the front or back cover.

Example

Man.No. I163E-EN-01A

↑
Revision symbol

Revision symbol	Revision date	Description of revision and revised page
01	November 2010	First Print.
01A	July 2013	Page 6-61: Explanation for parameter number Pn925 and Pn926 corrected

Structure of This Document

This manual consists of the following chapters.
Read the necessary chapter or chapters referring to below.

		Outline
Chapter 1	Features and System Configuration	This chapter explains the features of this product, name of each part, and applicable EC directives and UL standards.
Chapter 2	Standard Models and External Dimensions	This chapter explains the models of Servo Drive, Linear Servo Motor, and peripheral equipment, as well as the external dimensions and mounting dimensions.
Chapter 3	Specifications	This chapter explains the general specifications, characteristics, connector specifications and I/O circuits of the Servo Drive, general specifications, characteristics, encoder specifications of the Linear Servo Motor, and all other specifications including those of peripheral equipment.
Chapter 4	System Design	This chapter explains the installation conditions, wiring methods including wiring conforming to EMC directives and how to calculate the regenerative energy depending on Servo Drive, Linear Servo Motor and application characteristics.
Chapter 5	BASIC CONTROL mode	This chapter explains an outline of operations available in various CONTROL modes and explains the contents of setting.
Chapter 6	Applied Functions	This chapter explains different functions such as anti-vibration control, electronic-gear, gain switching and disturbance observer, and explains the contents of settings. Also explains how to setup Linear Servo Motor parameters and encoder.
Chapter 7	Safety Function	This function stops the motor based on a signal from a Safety Controller or safety sensor. An outline of the function is explained together with operation and connection examples.
Chapter 8	Parameters Details	This chapter explains the set value and contents of setting of each parameter.
Chapter 9	Operation	This chapter explains the operating procedures and how to operate in each mode.
Chapter 10	Adjustment Functions	This chapter explains the functions, setting methods and items to note regarding various gain adjustments.
Chapter 11	Error and Maintenance	This chapter explains the items to check when problems occur, error diagnosis using the alarm LED display and measures, error diagnosis based on the operating condition and measures, and periodic maintenance.
Chapter 12	Appendix	This chapter provides connection examples using OMRON's PLC and Position Controller, as well as a list of parameters.

Table Of Contents

Introduction	1
Items Requiring Acknowledgment	2
Safety Precautions Document	4
Items to Check after Unpacking	12
Manual Revision History	13
Structure of This Document	14
Chapter 1 Features and System Configuration	
1-1 Outline	1-2
1-2 System Configuration	1-3
1-3 Names and Functions.....	1-4
1-4 System Block Diagrams	1-6
1-5 Applicable Standards.....	1-11
Chapter 2 Standard Models and External Dimensions	
2-1 Servo System Configuration.....	2-2
2-2 How to Read Model	2-4
2-3 Standard Model List.....	2-7
2-4 External and Mounting Dimensions.....	2-17
2-5 EMC Filter Dimensions.....	2-39
Chapter 3 Specifications	
3-1 Drive Specifications	3-3
3-2 Overload Characteristics (Electronic Thermal Function)	3-55
3-3 Motor Specifications	3-56
3-4 Encoder, Hall sensor and Serial Converter	3-76
3-5 Cable and Connector Specifications	3-87
3-6 Servo Relay Units and Cable Specifications	3-112
3-7 External Regeneration Resistor Specifications	3-130
3-8 EMC Filter Specifications	3-132
Chapter 4 System Design	
4-1 Installation Conditions	4-2
4-2 Wiring	4-16
4-3 Wiring Conforming to EMC Directives	4-30
4-4 Regenerative Energy Absorption.....	4-44
Chapter 5 BASIC CONTROL Mode	
5-1 Position Control	5-2
5-2 Speed Control.....	5-8
5-3 Force Control.....	5-14
5-4 Internally Set Speed Control.....	5-19
5-5 Switching Control.....	5-22

Table Of Contents

Chapter 6 Applied Functions

6-1	Anti-vibration Control	6-3
6-2	Adaptive Filter.....	6-7
6-3	Notch Filter	6-9
6-4	Electronic Gear Function	6-12
6-5	Encoder Dividing Function.....	6-14
6-6	Brake Interlock.....	6-18
6-7	Gain Switching Function.....	6-23
6-8	Gain Switching 3 Function.....	6-31
6-9	Force Limit.....	6-32
6-10	Sequence I/O Signal.....	6-35
6-11	Forward and Reverse Drive Prohibition Functions	6-41
6-12	Disturbance Observer Function.....	6-44
6-13	Friction Force Compensation Function.....	6-46
6-14	Mass Ratio Switching Function	6-48
6-15	Feed-forward Function	6-49
6-16	Instantaneous Speed Observer Function	6-53
6-17	Motor Setup	6-55
6-18	Encoder Setup.....	6-58
6-19	Magnetic Pole Position	6-61
6-20	Setup with Serial Converter.....	6-64

Chapter 7 Safety Function

7-1	Safe Force OFF (STO) Function	7-2
7-2	Operation Example.....	7-5
7-3	Connection Example	7-7

Chapter 8 Parameters Details

8-1	Basic Parameters	8-2
8-2	Gain Parameters	8-9
8-3	Vibration Suppression Parameters.....	8-20
8-4	Analog Control Parameters	8-25
8-5	Interface Monitor Setting Parameters.....	8-35
8-6	Extended Parameters.....	8-45
8-7	Special Parameters	8-57
8-8	Linear Motor And Encoder Setting Parameters.....	8-62

Chapter 9 Operation

9-1	Operational Procedure	9-2
9-2	Preparing for Operation.....	9-3
9-3	Using the Front Display	9-10
9-4	Setting the Mode	9-11
9-5	Trial Operation.....	9-35

Chapter 10 Adjustment Functions

10-1	Gain Adjustment	10-2
10-2	Realtime Autotuning	10-4
10-3	Manual Tuning	10-12

Chapter 11 Error and Maintenance

11-1	Error Processing	11-2
11-2	Warning List	11-5
11-3	Alarm List	11-6
11-4	Troubleshooting	11-11
11-5	Periodic Maintenance	11-23

Chapter 12 Appendix

12-1	Connection Examples	12-2
12-2	Parameter List	12-12
12-3	Safety Certification	12-37

Index



1

Features and System Configuration

This chapter explains the features of this product, name of each part, and applicable EC directives and UL standards.

1-1	Outline	1-2
	Outline of the Accurax G5-Linear.....	1-2
	Features of the Accurax G5-Linear.....	1-2
1-2	System Configuration	1-3
1-3	Names and Functions	1-4
	Drive Part Names.....	1-4
	Drive Functions	1-5
1-4	System Block Diagrams.....	1-6
1-5	Applicable Standards	1-11
	EC Directives	1-11
	UL and cUL Standards.....	1-11
	Functional Safety	1-11

1-1 Outline

Outline of the Accurax G5-Linear

With the Accurax G5-Linear, you can perform position, speed and Force control. 2 linear motor families with various models are available for a wide range of forces. Drives with supplies of 100V, 200V or 400V depending on the required maximum speed available. You will surely find a model that best suits your application.

The Accurax G5-Linear features realtime autotuning function and adaptive filter function that automatically perform complex gain adjustments. A notch filter can also be automatically set to suppress machine vibration by reducing machine resonance during operation. The anti-vibration control function of the Linear Servo Drive realizes stable stopping performance in a mechanism which vibrates because of the low rigidity of the load.

Features of the Accurax G5-Linear

The Accurax G5-Linear has the following features.

6 Possible CONTROL modes Switching

You can switch among 6 CONTROL modes including the following: (1) position control, (2) speed control, (3) force control, (4) position and speed control, (5) position and force control, (6) speed and force control. Desired modes can be selected in the drive according to your need. A single drive support different modes.

Two motor families to Match Any Necessity

The Accurax G5-Linear servomotors have two families. G-family for the highest acceleration & low-medium force application and F-family for the high speed and wide force range application.

Safe Force OFF (STO) Function to Ensure Safety

You can cut off the motor current to stop the motor based on a signal from an immediate stop button or other safety equipment. In addition to the conventional stop method based on a control signal, the STO function that permits direct stopping without a need to involve the control circuit provides the immediate stop from 2 systems, thereby enhancing safety.

Wide Range of Power Supplies to Match Any maximum speed

The same Accurax G5-Linear servomotor can be controlled with a servodrive of 100V, 200V or 400V in order to reach different maximum speeds (see the Velocity-Force curves of each motor).

1-2 System Configuration

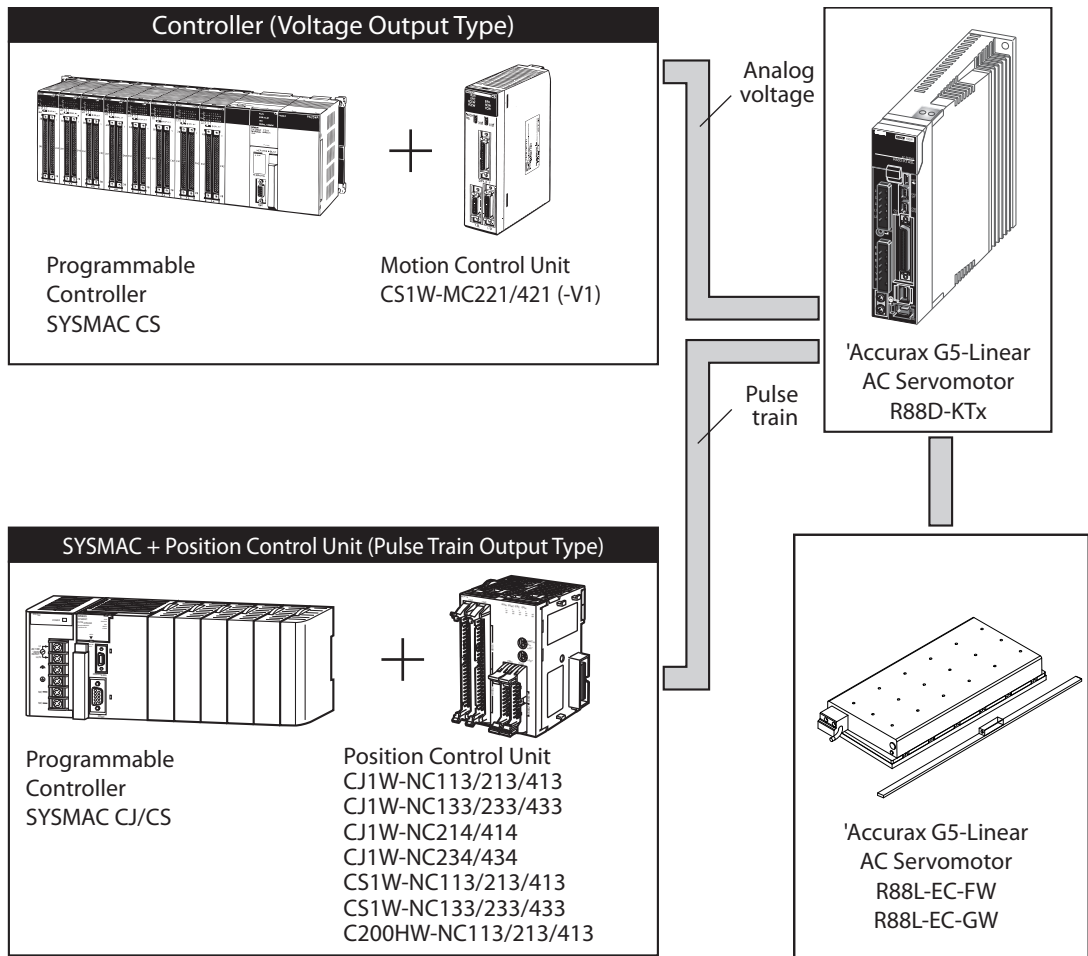

1-3 Names and Functions

Drive Part Names

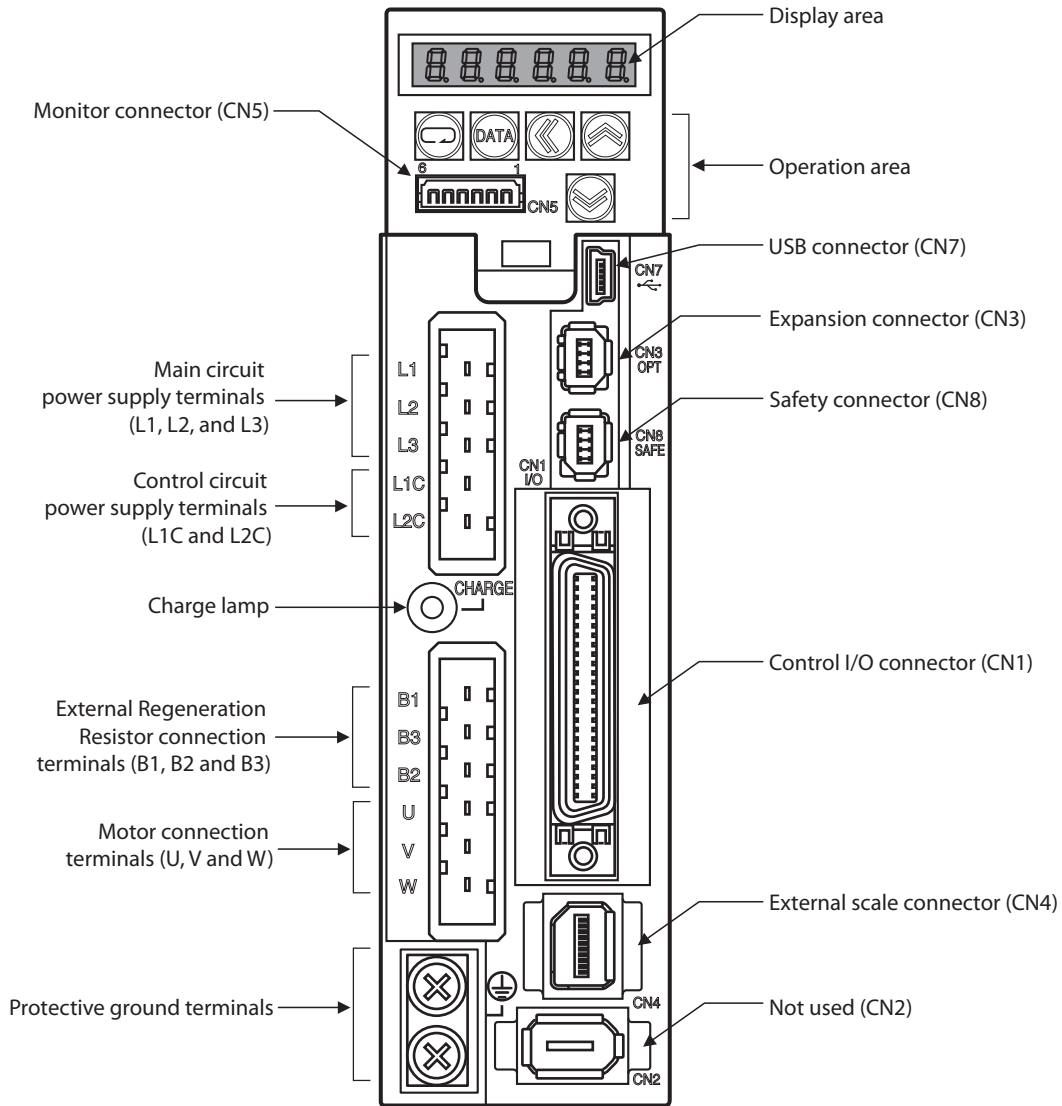

Drive Functions

Display Area

A 6-digit 7-segment LED display shows the drive status, alarm codes, parameters, and other information.

Operation Area

Monitors the parameter setting and drive condition.

Charge Lamp

Lits when the main circuit power supply is turned ON.

Control I/O Connector (CN1)

Used for command input signals and I/O signals.

Not used (CN2)

This connector is not used in the Accurax G5-Linear servodrive.

Expansion Connector (CN3)

A spare connector for expansion. Do not connect anything.

External Scale Connector (CN4)

Connector for the external linear encoder (if A/B type is used) or the Serial Converter (if SINCOS type is used).

Monitor Connector (CN5)

2 analog outputs to monitor values like motor movement speed, force command value, etc.

USB Connector (CN7)

Communications connector for the computer.

Safety Connector (CN8)

Connector for the safety devices.
If no safety device is used, keep the factory-set safety bypass connector installed.

1-4 System Block Diagrams

Size A: R88D-KT01L-L/-02H-L

Size B: R88D-KT02L-L/-04H-L

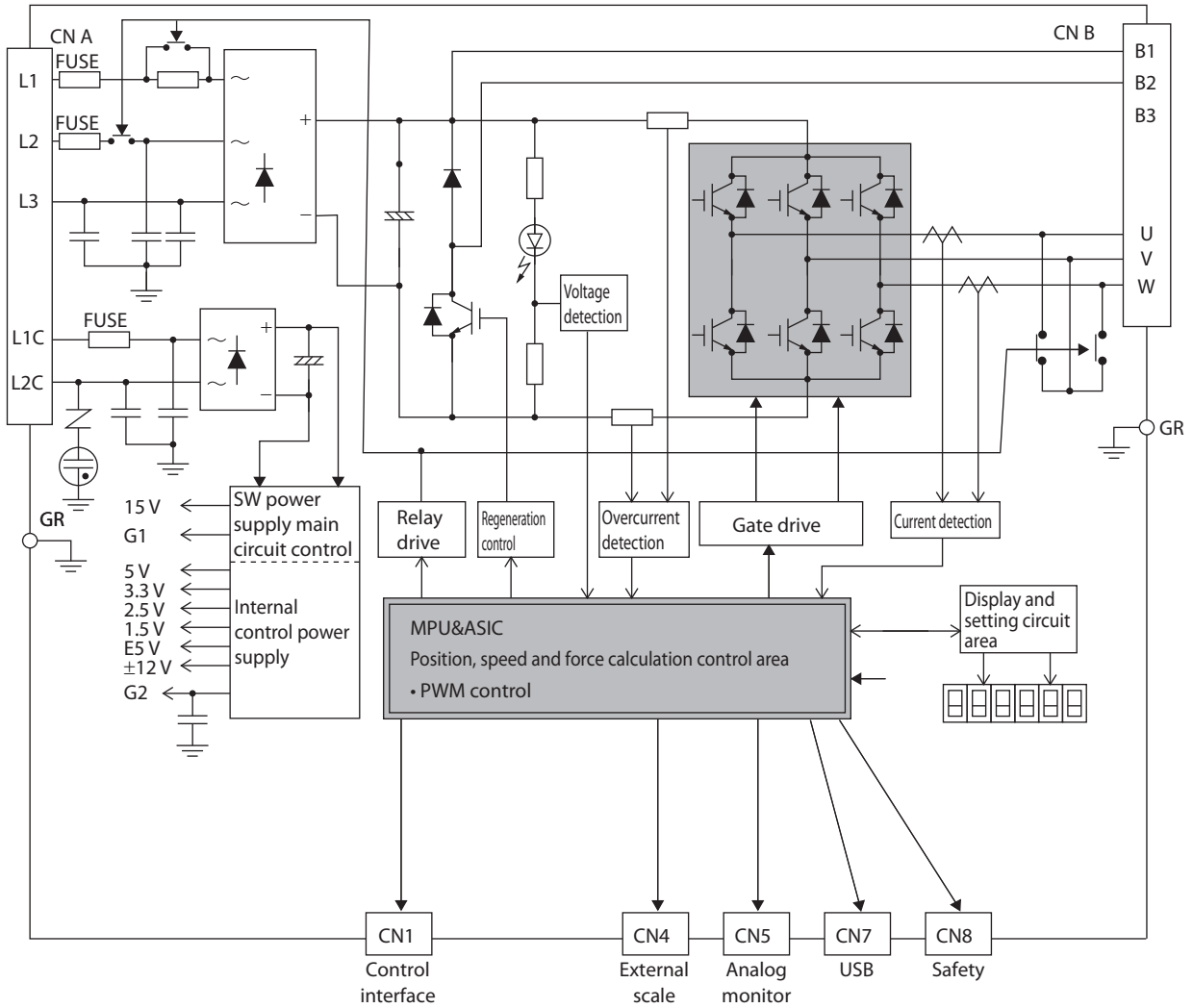

1

Features and System Configuration

Size C: R88D-KT04L-L/-08H-L
 Size D: R88D-KT10H-L/-15H-L

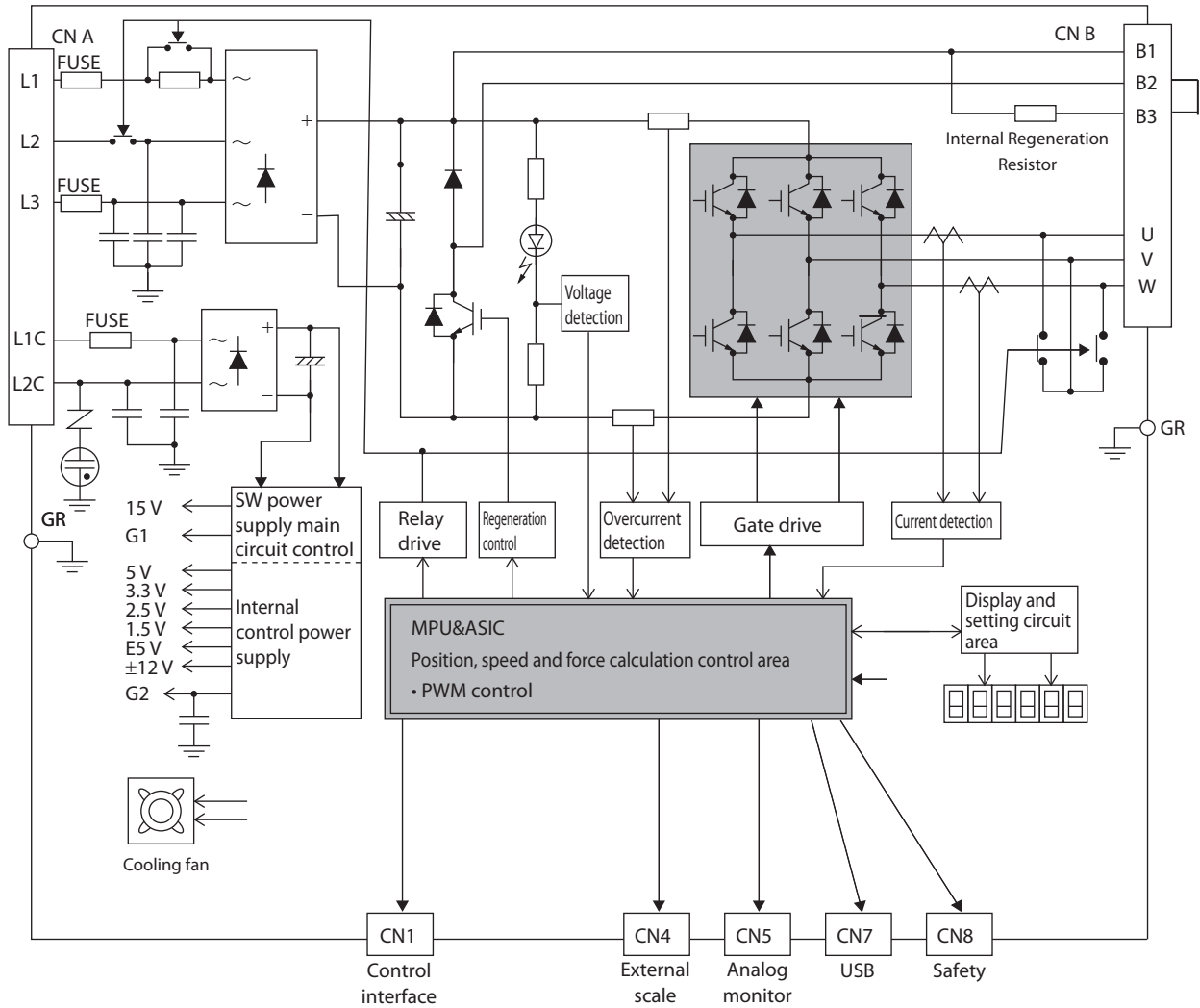

1-4 System Block Diagrams

Size D: R88D-KT06F-L/-10F-L/-15F-L

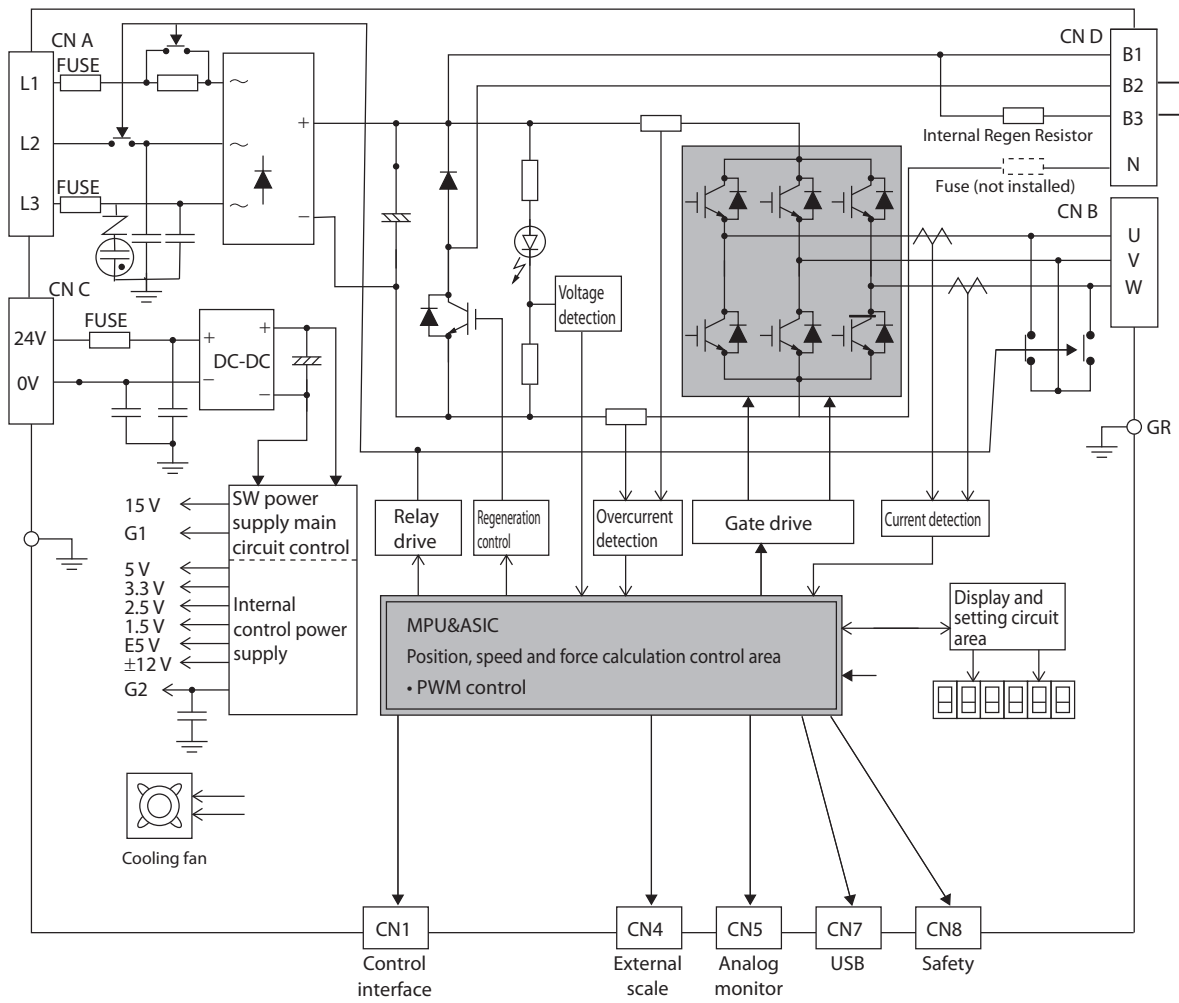

1 Features and System Configuration

Size E: R88D-KT20H-L

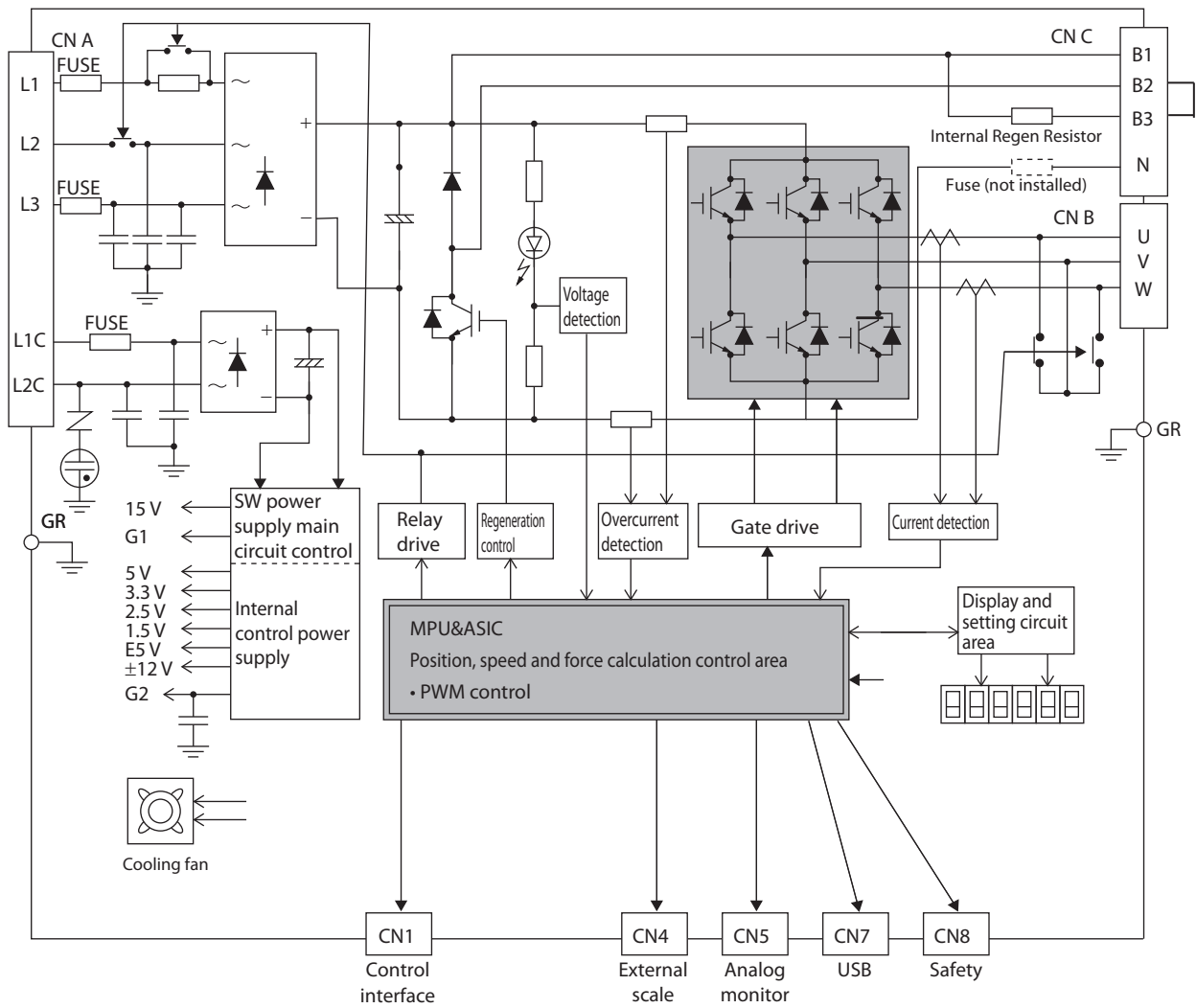

1-4 System Block Diagrams

Size E: R88D-KT20F-L
 Size F: R88D-KT30F-L/-50F-L

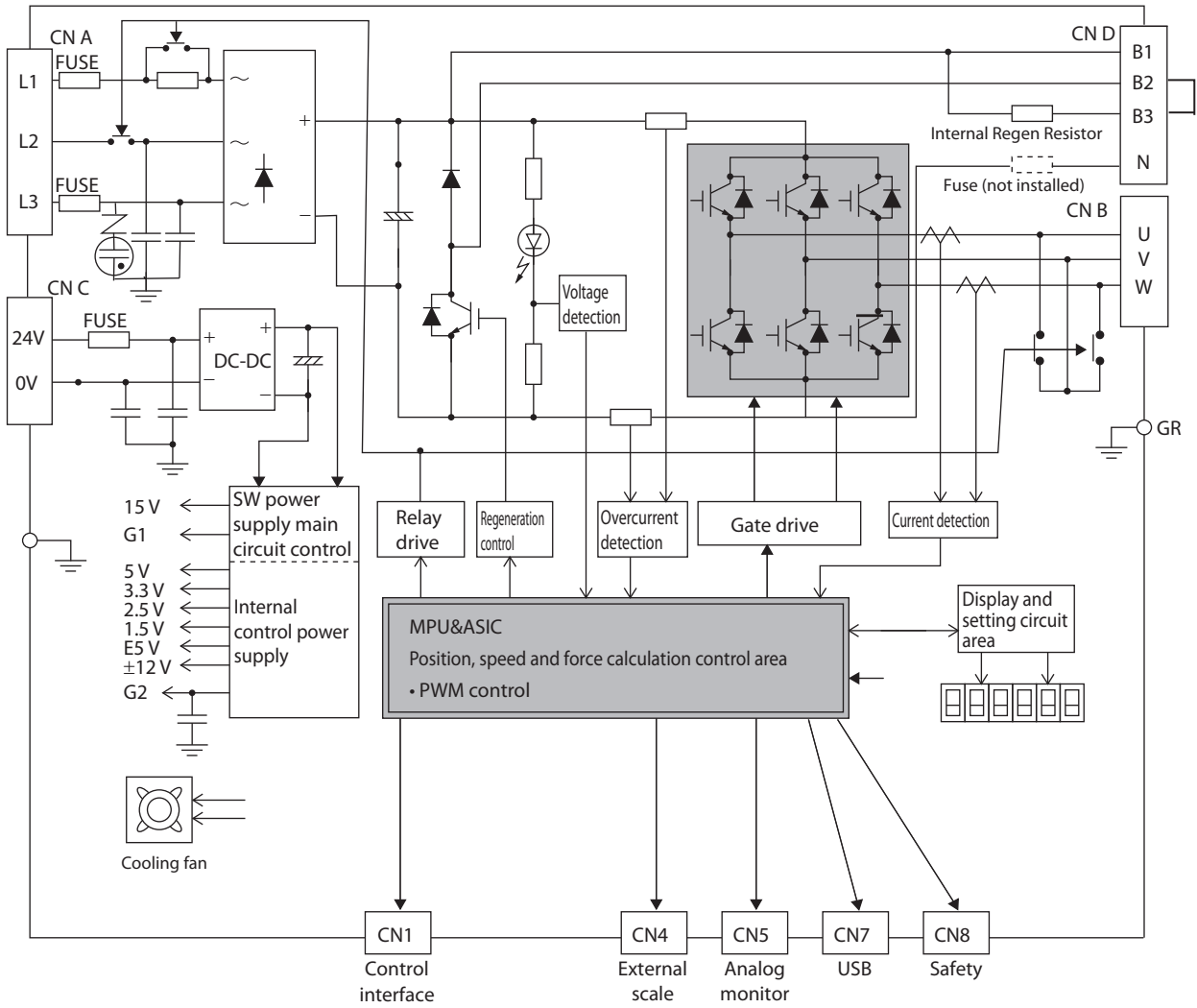

1 Features and System Configuration

1-5 Applicable Standards

EC Directives

EC directive	Product	Applicable standards
Low voltage directive	AC Linear Servo Drive	EN 61800-5-1
	AC Linear Servomotor	EN 60034-1: 2004
		EN 60204-1: 2006
EMC directives	AC Linear Servo Drive	EN 55011 class A group 1
		IEC61800-3
		EN61000-6-2

Note. To conform to EMC directives, the Linear Servo Motor and Servo Drive must be installed under the conditions described in "4-3 Wiring Conforming to EMC Directives" (P.4-30).

UL and cUL Standards

Standard	Product	Applicable standards	File number
UL standards	AC Linear Servo Drive	UL508C	E179149
CSA standards	AC Linear Servo Drive	CSA22.2 No. 14	E179149

All components in the linear motors are UL certified.

Functional Safety

Standard	Product	Applicable standards
Functional safety	AC Linear Servo Drive	EN954-1 (Category 3) ISO13849-1 (Performance level D) EN61508 (SIL2) EN62061 (SIL2) EV61800-5-2 (STO) IEC61326-3-1 (SIL2)

2

Standard Models and External Dimensions

This chapter explains the models of Servo Drive, Linear Servo Motor, and peripheral equipment, as well as the external dimensions and mounting dimensions.

2-1	Servo System Configuration	2-2
2-2	How to Read Model.....	2-4
	Linear Servo Drive	2-4
	Linear Servomotor	2-5
2-3	Standard Model List	2-7
	Linear Servo Drive Model List.....	2-7
	Linear Servomotor Model List.....	2-8
	Linear Servo Drive and Servomotor Combination List.....	2-9
	Peripheral Equipment and Cable Model List.....	2-11
2-4	External and Mounting Dimensions.....	2-17
	Linear Servo Drive Dimensions	2-17
	Linear Servomotor Dimensions.....	2-27
	External Regeneration Resistor Dimensions	2-38
2-5	EMC Filter Dimensions.....	2-39

2-1 Servo System Configuration

2

Standard Models and External Dimensions

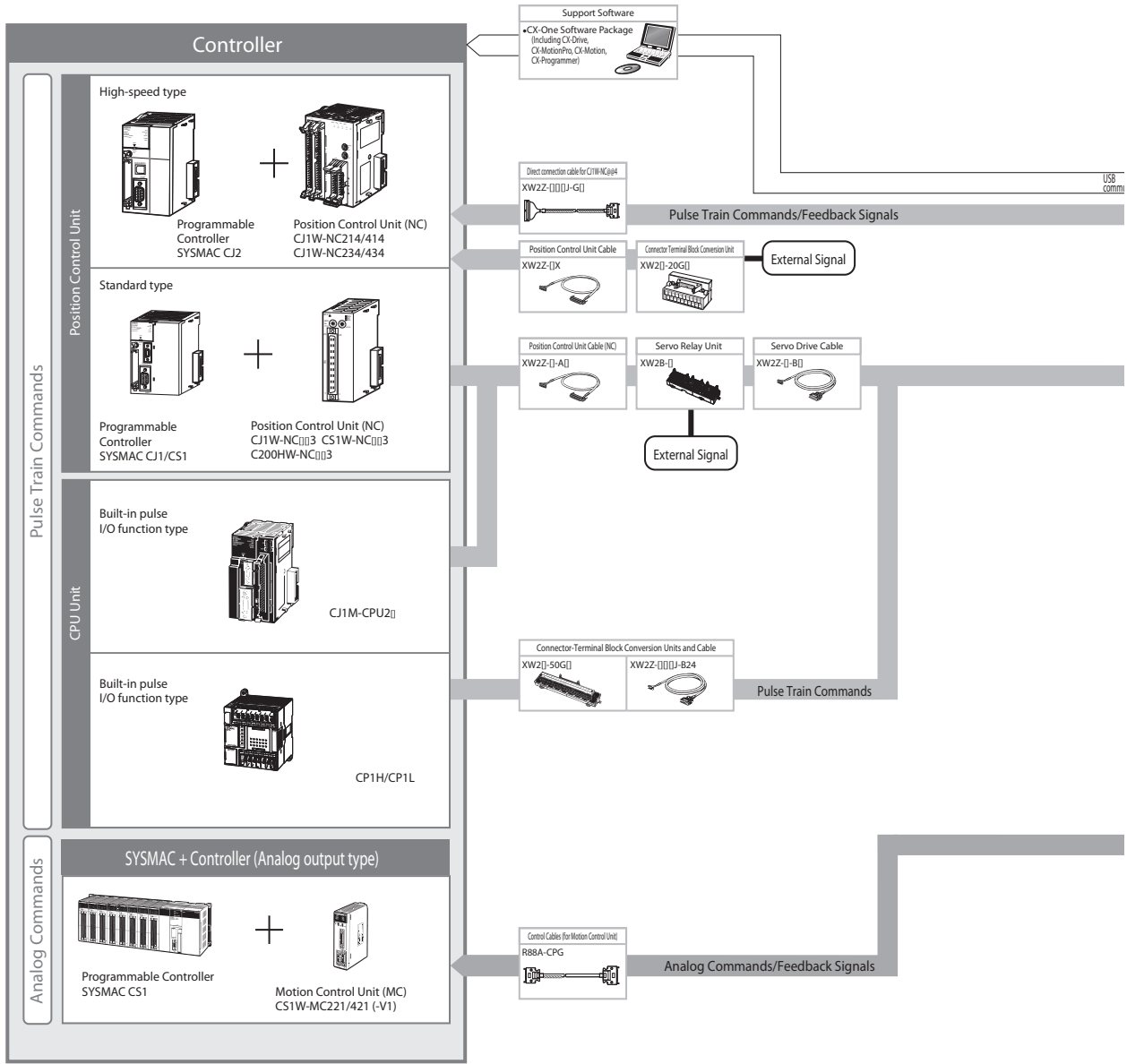

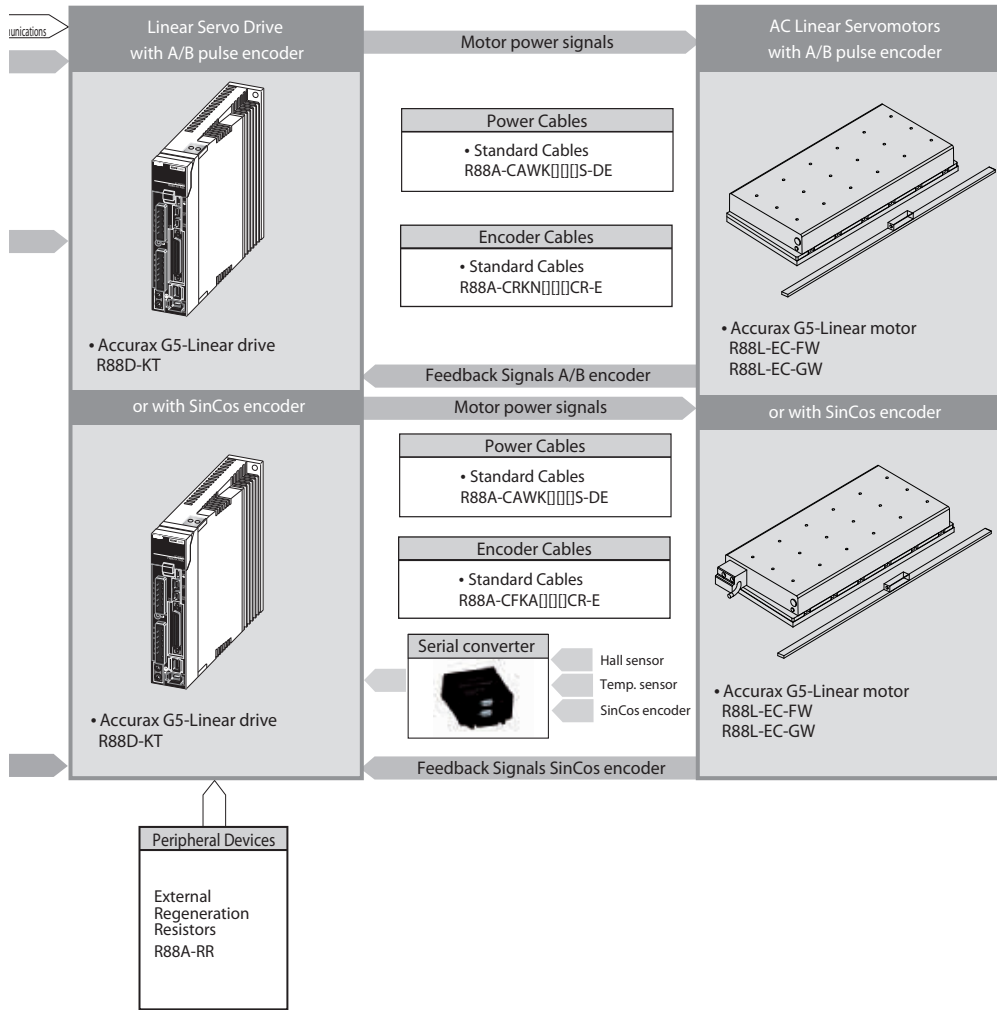

2-2 How to Read Model

Linear Servo Drive

The Linear Servo Drive model can be identified by the Linear Servo Drive type, applicable Linear Servomotor capacity, power supply voltage, etc.

R88D-KT02H-L

Accurax G5-Linear Series Servomotor

Drive Type

T : Pulse/analog type

Capacity

- 01 : 100 W
- 02 : 200 W
- 04 : 400 W
- 06 : 600 W
- 08 : 800 W
- 10 : 1 kW
- 15 : 1.5 kW
- 20 : 2 kW
- 30 : 3 kW
- 50 : 5 kW

Power Supply Voltage

- L : 100 VAC
- H : 200 VAC
- F : 400 VAC

Linear type drive

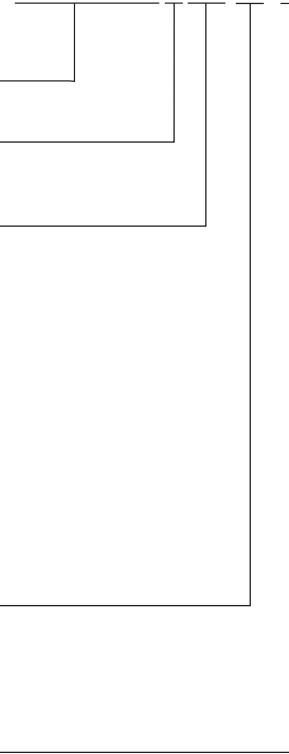

Linear Servomotor

Iron-core family

Linear motor coil

R88L-EC-FW-0303-ANPC

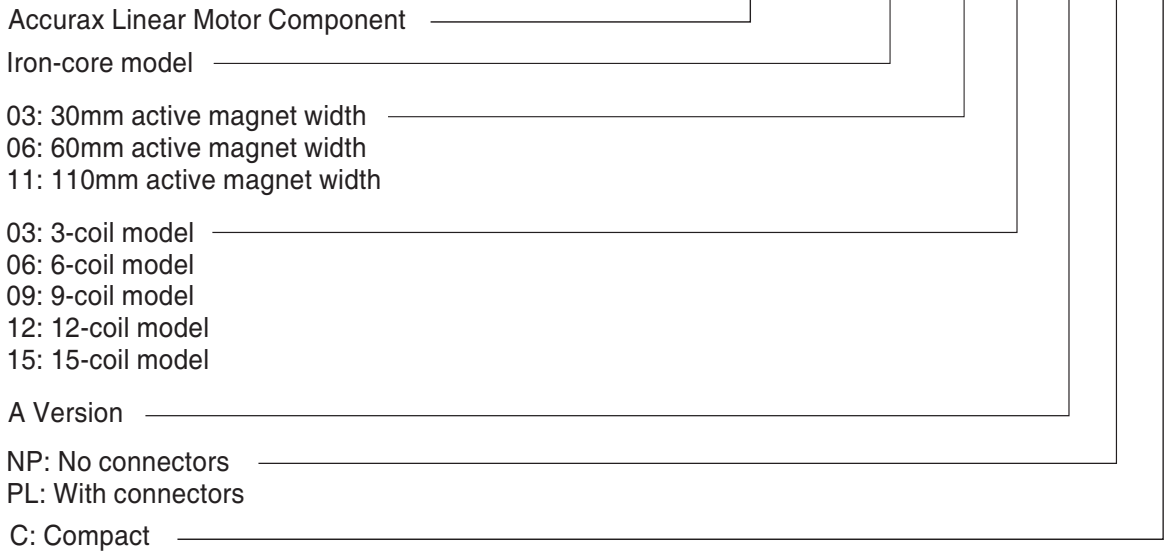

Magnet track

R88L-EC-FM-03xxx-A

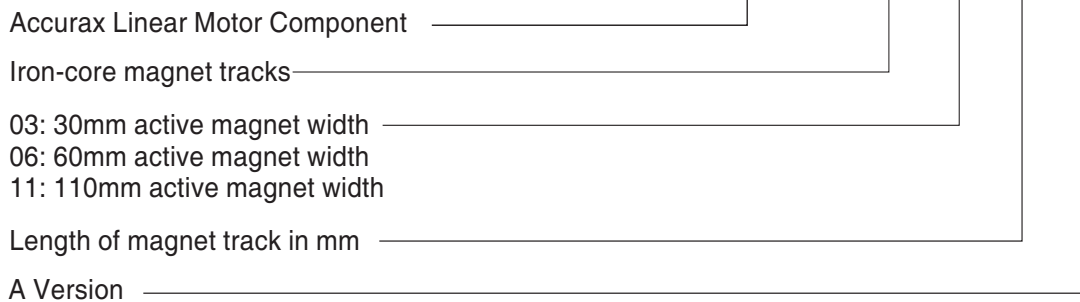

Hall sensor

R88L-EC-FH-NNNN-A



2-2 How to Read Model

Ironless family

Linear motor coil

R88L-EC-GW-0303-ANPS

Accurax Linear Motor Component

Ironless coil

03: 30mm active magnet width

05: 50mm active magnet width

07: 70mm active magnet width

03: 3-coil model

06: 6-coil model

09: 9-coil model

A Version

NP: No connectors

PL: With connectors

S: Standard

Magnet track

R88L-EC-GM-03xxx-A

Accurax Linear Motor Component

Ironless magnet yoke

03: 30mm active magnet width

05: 50mm active magnet width

07: 70mm active magnet width

Length of magnet track in mm

A Version

Hall sensor

R88L-EC-GH-03NN-A

Accurax Linear Motor Component

Digital hall-sensor for G-series

03: 30mm active magnet width

05: 50mm active magnet width

07: 70mm active magnet width

Placeholder

A Version

2-3 Standard Model List

Linear Servo Drive Model List

Specifications		Model
Single-phase 100 VAC	100 W	R88D-KT01L-L
	200 W	R88D-KT02L-L
	400 W	R88D-KT04L-L
Single-phase/3-phase 200 VAC	200 W	R88D-KT02H-L
	400 W	R88D-KT04H-L
	800 W	R88D-KT08H-L
	1 kW	R88D-KT10H-L
	1.5 kW	R88D-KT15H-L
3-phase 200 VAC	2 kW	R88D-KT20H-L
3-phase 400 VAC	600W	R88D-KT06F-L
	1 kW	R88D-KT10F-L
	1.5 kW	R88D-KT15F-L
	2 kW	R88D-KT20F-L
	3 kW	R88D-KT30F-L
	5 kW	R88D-KT50F-L

Linear Servomotor Model List

Iron-core linear servomotor model list

Coil without connectors	Coil with connectors	Nominal force (N)	Peak force (N)	Magnet track	Hall sensor
R88L-EC-FW-0303-ANPC	R88L-EC-FW-0303-APLC	48	105	R88L-EC-FM-03096-A	R88L-EC-FH-NNNN-A
R88L-EC-FW-0306-ANPC	R88L-EC-FW-0306-APLC	96	210	R88L-EC-FM-03144-A R88L-EC-FM-03384-A	
R88L-EC-FW-0606-ANPC	R88L-EC-FW-0606-APLC	160	400	R88L-EC-FM-06192-A R88L-EC-FM-06288-A	
R88L-EC-FW-0609-ANPC	R88L-EC-FW-0609-APLC	240	600		
R88L-EC-FW-0612-ANPC	R88L-EC-FW-0612-APLC	320	800		
R88L-EC-FW-1112-ANPC	R88L-EC-FW-1112-APLC	608	1600	R88L-EC-FM-11192-A	
R88L-EC-FW-1115-ANPC	R88L-EC-FW-1115-APLC	760	2000	R88L-EC-FM-11288-A	

Ironless linear servomotor model list

Coil without connectors	Coil with connectors	Nominal force (N)	Peak force (N)	Magnet track	Hall sensor
R88L-EC-GW-0303-ANPS	R88L-EC-GW-0303-APLS	26,5	100	R88L-EC-GM-03090-A	R88L-EC-GH-03NN-A
R88L-EC-GW-0306-ANPS	R88L-EC-GW-0306-APLS	53	200	R88L-EC-GM-03120-A R88L-EC-GM-03390-A	
R88L-EC-GW-0309-ANPS	R88L-EC-GW-0309-APLS	80	300		
R88L-EC-GW-0503-ANPS	R88L-EC-GW-0503-APLS	58	240	R88L-EC-GM-05126-A	R88L-EC-GH-05NN-A
R88L-EC-GW-0506-ANPS	R88L-EC-GW-0506-APLS	117	480	R88L-EC-GM-05546-A R88L-EC-GM-05168-A	
R88L-EC-GW-0509-ANPS	R88L-EC-GW-0509-APLS	175	720	R88L-EC-GM-05210-A	
R88L-EC-GW-0703-ANPS	R88L-EC-GW-0703-APLS	117	700	R88L-EC-GM-07114-A	R88L-EC-GH-07NN-A
R88L-EC-GW-0706-ANPS	R88L-EC-GW-0706-APLS	232	1400	R88L-EC-GM-07171-A	
R88L-EC-GW-0709-ANPS	R88L-EC-GW-0709-APLS	348	2100	R88L-EC-GM-07456-A	

Linear Servo Drive and Servomotor Combination List

The tables in this section show the optimum combination of Accurax G5-Linear Servo Drives and Servomotors. The selection is based in matching the nominal and peak current of the motor with the minimum switching frequency (6KHz or 12KHz depending on the drive).

Other non optimum combination are possible for:

- Using higher PWM frequency (results in a bigger drive).
- Reduce the drive size in the maximum peak force of the motor is not needed.
- Oversize the drive.

Refer to the CX-Drive for the complete combination list.

Iron-core family

Motor	Voltage (V)	Drive	PWM frequency (KHz)	Max. speed (m/s)
R88L-EC-FW-0303	100	R88D-KT01L-L	12	2,5
	200	R88D-KT02H-L	12	5
	400	R88D-KT06F-L	6	10
R88L-EC-FW-0306	100	R88D-KT02L-L	6	2,5
	200	R88D-KT04H-L	6	5
	400	R88D-KT10F-L	6	10
R88L-EC-FW-0606	100	R88D-KT04L-L	6	2
	200	R88D-KT08H-L	6	4
	400	R88D-KT15F-L	6	8
R88L-EC-FW-0609	100	Not match	-	2
	200	R88D-KT10H-L	6	4
	400	R88D-KT20F-L	6	8
R88L-EC-FW-0612	100	Not match	-	2
	200	R88D-KT15H-L	6	4
	400	R88D-KT30F-L	6	8
R88L-EC-FW-1112	100	Not match	-	1
	200	R88D-KT15H-L	6	2
	400	R88D-KT30F-L	6	4
R88L-EC-FW-1115	100	Not match	-	1
	200	R88D-KT15H-L	6	2
	400	R88D-KT30F-L	6	4

Ironless family

Motor	Voltage (V)	Drive	PWM frequency (KHz)	Max. speed (m/s)
R88L-EC-GW-0303	100	R88D-KT01L-L	12	8
	200	R88D-KT02H-L	12	16
R88L-EC-GW-0306	100	R88D-KT04L-L	6	8
	200	R88D-KT08H-L	6	16
R88L-EC-GW-0309	100	Not match	-	8
	200	R88D-KT10H-L	6	16
R88L-EC-GW-0503	100	R88D-KT01L-L	12	2,2
	200	R88D-KT02H-L	12	4,4
R88L-EC-GW-0506	100	R88D-KT02L-L	6	2,2
	200	R88D-KT04H-L	6	4,4
R88L-EC-GW-0509	100	R88D-KT04L-L	6	2,2
	200	R88D-KT08H-L	6	4,4
R88L-EC-GW-0703	100	R88D-KT02L-L	6	1,2
	200	R88D-KT04H-L	6	2,4
R88L-EC-GW-0706	100	R88D-KT04L-L	6	1,2
	200	R88D-KT08H-L	6	2,4
R88L-EC-GW-0709	100	Not match	-	1,2
	200	R88D-KT10H-L	6	2,4

Peripheral Equipment and Cable Model List

Encoder Cable (A/B Encoder)

From Encoder connector (DB-15 male with Numerik jena pinout) to CN4 connector in servodrive.

Specifications		Model
For Iron-core and Ironless linear motors with connectors	1.5 m	R88A-CRKN001-5CR-E
	3 m	R88A-CRKN003CR-E
	5 m	R88A-CRKN005CR-E
	10 m	R88A-CRKN010CR-E
	15 m	R88A-CRKN015CR-E
	20 m	R88A-CRKN020CR-E

Encoder Cable (SinCos Encoder)

From Encoder connector (DB-15 male with Numerik jena pinout) to CN4 connector in Serial Converter.

Specifications		Model
For Iron-core and Ironless linear motors with connectors	1.5 m	R88A-CFKA001-5CR-E
	3 m	R88A-CFKA003CR-E
	5 m	R88A-CFKA005CR-E
	10 m	R88A-CFKA010CR-E
	15 m	R88A-CFKA015CR-E

Motor power cable

Specifications		Model
For Iron-core linear motors with connectors	1.5 m	R88A-CAWK001-5S-DE
	3 m	R88A-CAWK003S-DE
	5 m	R88A-CAWK005S-DE
	10 m	R88A-CAWK010S-DE
	15 m	R88A-CAWK015S-DE
	20 m	R88A-CAWK020S-DE
For Ironless linear motors with connectors	1.5 m	R88A-CAWB001-5S-DE
	3 m	R88A-CAWB003S-DE
	5 m	R88A-CAWB005S-DE
	10 m	R88A-CAWB010S-DE
	15 m	R88A-CAWB015S-DE
	20 m	R88A-CAWB020S-DE

Serial Converter

The Serial Converter is an interface that is necessary when we want to connect to the servodrive either SinCos Encoder, hall sensor or temperature sensor.

The use of the SinCos with the Serial Converter is mandatory, the use of hall sensor or temperature sensor is optional.

Specifications	Model
Serial Converter Unit from 1Vpp to G5 Serial Converter data transmission (With KTY sensor detection of Iron-core motor coil)	R88A-SC01K-E
Serial Converter Unit from 1Vpp to G5 Serial Converter data transmission (With NTC sensor detection of Ironless motor coil)	R88A-SC02K-E

Serial Converter cable

From Serial Converter CN1 connector to servodrive CN4 connector.

Specifications	Model	
For Iron-core and Ironless linear motors with connectors	1.5 m	R88A-CRKN001-5CR-E
	3 m	R88A-CRKN003CR-E
	5 m	R88A-CRKN005CR-E
	10 m	R88A-CRKN010CR-E
	15 m	R88A-CRKN015CR-E
	20 m	R88A-CRKN020CR-E

Hall and temperature sensors cable to serial converter

Specifications	Model	
Extension cable from Hall and Temperature sensors to Serial Converter. (Connector DB-9) (This extension cable is optional)	1.5 m	R88A-CFKB001-5CR-E
	3 m	R88A-CRKB003CR-E
	5 m	R88A-CRKB005CR-E
	10 m	R88A-CRKB010CR-E
	15 m	R88A-CRKB015CR-E
	20 m	R88A-CRKB020CR-E

Analog Monitor Cable

From CN5 connector to flat cables.

Specifications	Model
Analog monitor cable	1 m R88A-CMK001S

Connectors

Specifications	Model
Linear Servo Drive external encoder connector (CN4)	R88A-CNK41L
Female connector for Hall and Temperature sensors	9 pin D-Sub female (Serial Converter side)
Male connector for Hall and Temperature sensors	9 pin D-Sub male (Motor side)
Female connector for SinCos	15 pin low density D-Sub female (Serial Converter side)
Male connector for SinCos	15 pin low density D-Sub male (Encoder side)
Hypertac power cable connector IP67 for Iron-core linear motors	LPRA-06B-FRBN170
Hypertac power cable connector IP67 for Ironless linear motors	SPOC06KFSDN169

Servo Relay Units (for CN1)

Specifications	Model
Servo Relay Unit For CS1W-NC113/-NC133 For CJ1W-NC113/-NC133 For C200HW-NC113	XW2B-20J6-1B
For CS1W-NC213/-NC413/-NC233/-NC433 For CJ1W-NC213/-NC413/-NC233/-NC433 For C200HW-NC213/-NC413	XW2B-40J6-2B
For CJ1M-CPU21/-CPU22/-CPU23	XW2B-20J6-8A XW2B-40J6-9A
For CQM1-CPU43-V1 For CQM1H-PLB21	XW2B-20J6-3B

Servo Relay Unit Cables for Linear Servo Drives

Specifications		Model	
Servo Drive cables	For CS1W-NC113/-NC133, CJ1W-NC113/-NC133, C200HW-NC113 (XW2B-20J6-1B) For CS1W-NC213/-NC413/-NC233/-NC433, CJ1W-NC213/-NC413/-NC233/-NC433, C200HW-NC213/-NC413 (XW2B-40J6-2B) For CQM1-CPU43-V1 or CQM1H-PLB21 (XW2B-20J6-3B)	1 m	XW2Z-100J-B25
		2 m	XW2Z-200J-B25
	For CJM1-CPU21/-CPU22/-CPU23 (XW2B-20J6-8A/XW2B-40J6-9A)	1 m	XW2Z-100J-B31
		2 m	XW2Z-200J-B31

Servo Relay Unit Cables for Position Control Units

Specifications		Model	
Position Control Unit cables	For CQM1H-PLB21 (XW2B-20J6-3B)	0.5 m	XW2Z-050J-A3
		1 m	XW2Z-100J-A3
	For CS1W-NC113, C200HW-NC113 (XW2B-20J6-1B)	0.5 m	XW2Z-050J-A6
		1 m	XW2Z-100J-A6
	For CS1W-NC213/-NC413, C200HW-NC213/-NC413 (XW2B-20J6-2B)	0.5 m	XW2Z-050J-A7
		1 m	XW2Z-100J-A7
	For CS1W-NC133 (XW2B-20J6-1B)	0.5 m	XW2Z-050J-A10
		1 m	XW2Z-100J-A10
	For CS1W-NC233/-NC433 (XW2B-20J6-2B)	0.5 m	XW2Z-050J-A11
		1 m	XW2Z-100J-A11
	For CJ1W-NC113 (XW2B-20J6-1B)	0.5 m	XW2Z-050J-A14
		1 m	XW2Z-100J-A14
	For CJ1W-NC213/-NC413 (XW2B-20J6-2B)	0.5 m	XW2Z-050J-A15
		1 m	XW2Z-100J-A15
	For CJ1W-NC133 (XW2B-20J6-1B)	0.5 m	XW2Z-050J-A18
		1 m	XW2Z-100J-A18
	For CJ1W-NC233/-NC433 (XW2B-20J6-2B)	0.5 m	XW2Z-050J-A19
		1 m	XW2Z-100J-A19
	For CJ1M-CPU21/-CPU22/-CPU23 (XW2B-20J6-8A/XW2B-40J6-9A)	0.5 m	XW2Z-050J-A33
		1 m	XW2Z-100J-A33

Control Cables

Specifications		Model
Specified cables for Position Control Unit (line-drive output for 1 axis) CJ1W-NC234/-NC434	1 m	XW2Z-100J-G9
	5 m	XW2Z-500J-G9
	10 m	XW2Z-10MJ-G9
Specified cables for Position Control Unit (open collector output for 1 axis) CJ1W-NC214/-NC414	1 m	XW2Z-100J-G13
	3 m	XW2Z-300J-G13
Specified cables for Position Control Unit (line-drive output for 2 axes) CJ1W-NC234/-NC434	1 m	XW2Z-100J-G13
	5 m	XW2Z-500J-G1
	10 m	XW2Z-10MJ-G1
Specified cables for Position Control Unit (open collector output for 2 axes) CJ1W-NC214/-NC414	1 m	XW2Z-100J-G5
	3 m	XW2Z-300J-G5
Specified cables for Motion Control Unit (for 1 axis) CS1W-MC221-V1/-MC421-V1	1 m	R88A-CPG001M1
	2 m	R88A-CPG002M1
	3 m	R88A-CPG003M1
	5 m	R88A-CPG005M1
Specified cables for Motion Control Unit (for 2 axes) CS1W-MC221-V1/-MC421-V1	1 m	R88A-CPG001M2
	2 m	R88A-CPG002M2
	3 m	R88A-CPG003M2
	5 m	R88A-CPG005M2
General control cables (with connector on one end)	1 m	R88A-CPG001S
	2 m	R88A-CPG002S
Connector-terminal block cables	1 m	XW2Z-100J-B24
	2 m	XW2Z-200J-B24
Connector-terminal block	M3 screw and for pin terminals	XW2B-50G4
	M3.5 screw and for fork/round terminals	XW2B-50G5
	M3 screw and for fork/round terminals	XW2D-50G6

External Regeneration Resistors

Specifications	Model
Regeneration process capacity: 20 W, 50 Ω (with 150°C thermal sensor)	R88A-RR08050S
Regeneration process capacity: 20 W, 100 Ω (with 150°C thermal sensor)	R88A-RR080100S
Regeneration process capacity: 70 W, 47 Ω (with 170°C thermal sensor)	R88A-RR22047S
Regeneration process capacity: 180 W, 20 Ω (with 200°C thermal sensor)	R88A-RR50020S

Mounting Brackets (L-Brackets for Rack Mounting)

Specifications	Model
R88D-KT01L-L/-KT02H-L	R88A-TK01K
R88D-KT02L-L/-KT04H-L	R88A-TK02K
R88D-KT04L-L/-KT08H-L	R88A-TK03K
R88D-KT10H-L/-KT15H-L	R88A-TK04K

Cable for Safety Functions (for CN8)

Specifications	Model
Safety connector with 3m cable (with loose wires at one end)	R88A-CSK003S-E

2-4 External and Mounting Dimensions

Linear Servo Drive Dimensions

Single-phase 100 VAC: R88D-KT01L-L (100 W)

Single-phase/3-phase 200 VAC: R88D-KT02H-L (200 W)

Wall Mounting

External dimensions

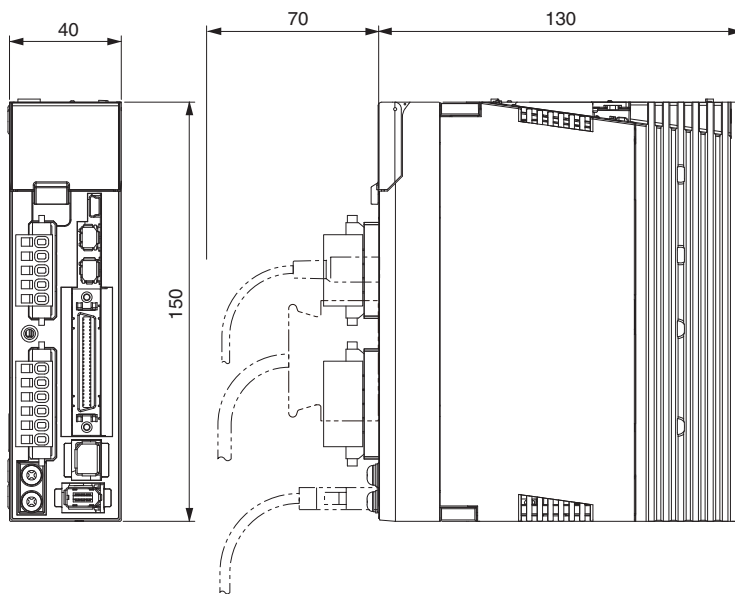

Mounting dimensions

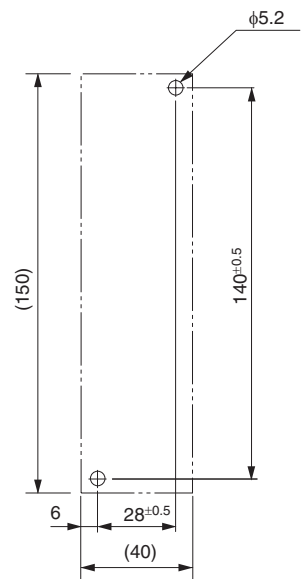

2-4 External and Mounting Dimensions

Front Mounting (Using Front Mounting Brackets)

External dimensions

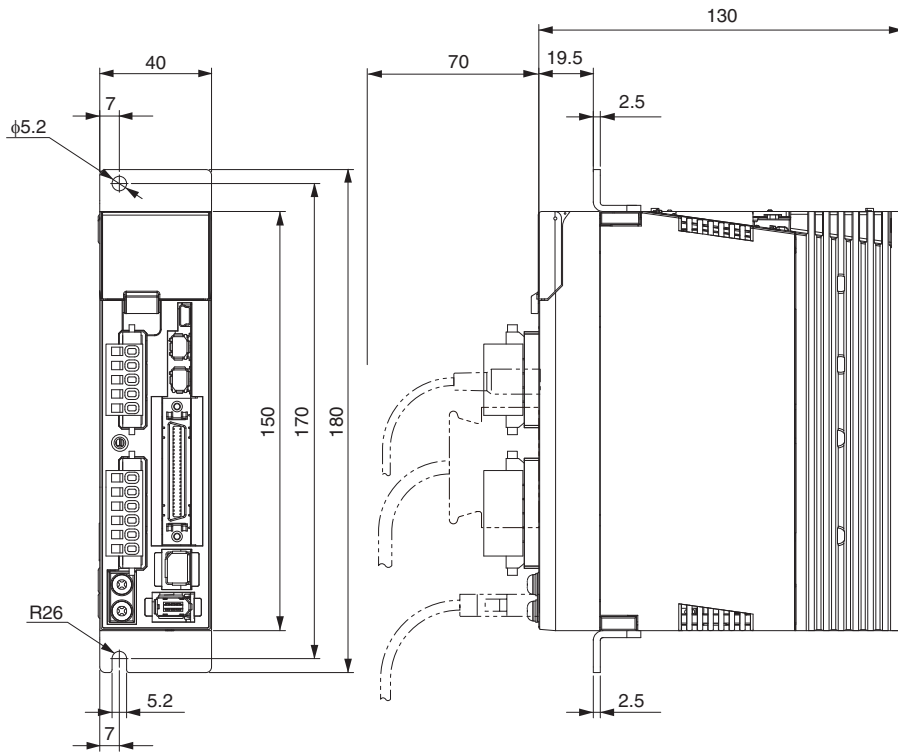

Mounting dimensions

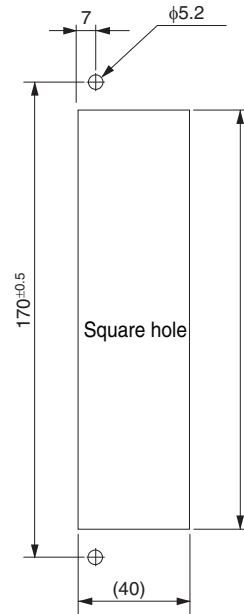

2

Standard Models and External Dimensions

Single-phase 100 VAC: R88D-KT02L-L (200 W)
 Single-phase/3-phase 200 VAC: R88D-KT04H-L (400 W)

Wall Mounting

External dimensions

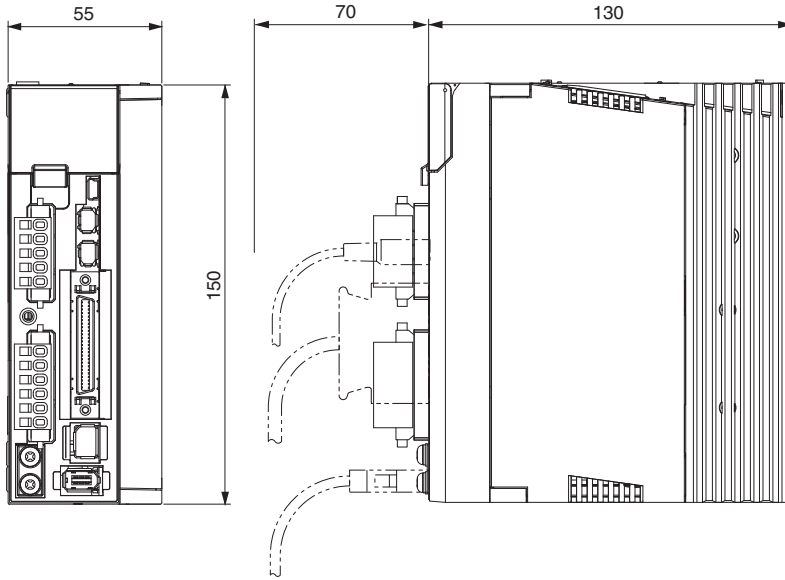

Mounting dimensions

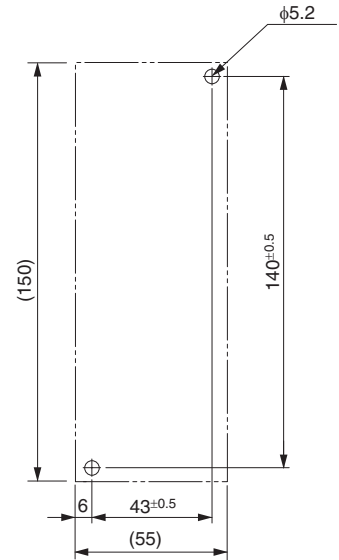

Front Mounting (Using Front Mounting Brackets)

External dimensions

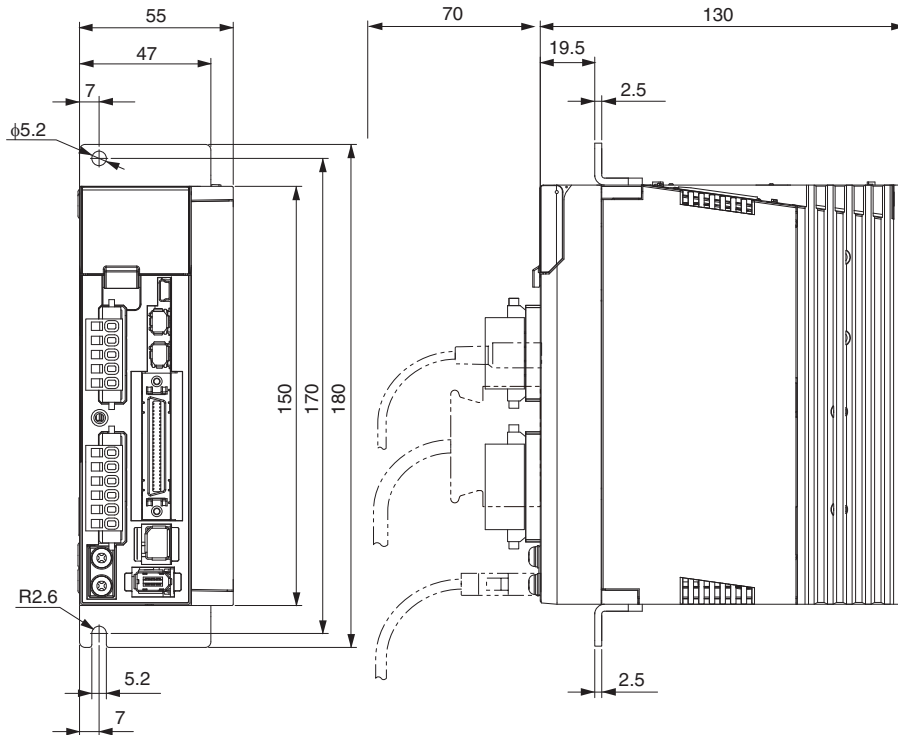

Mounting dimensions

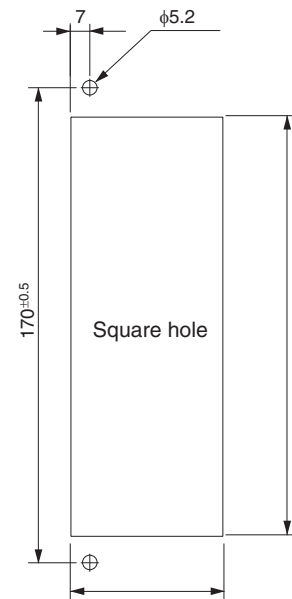

2-4 External and Mounting Dimensions

Single-phase 100 VAC: R88D-KT04L-L (400 W)
 Single-phase/3-phase 200 VAC: R88D-KT08H-L (800 W)

Wall Mounting

External dimensions

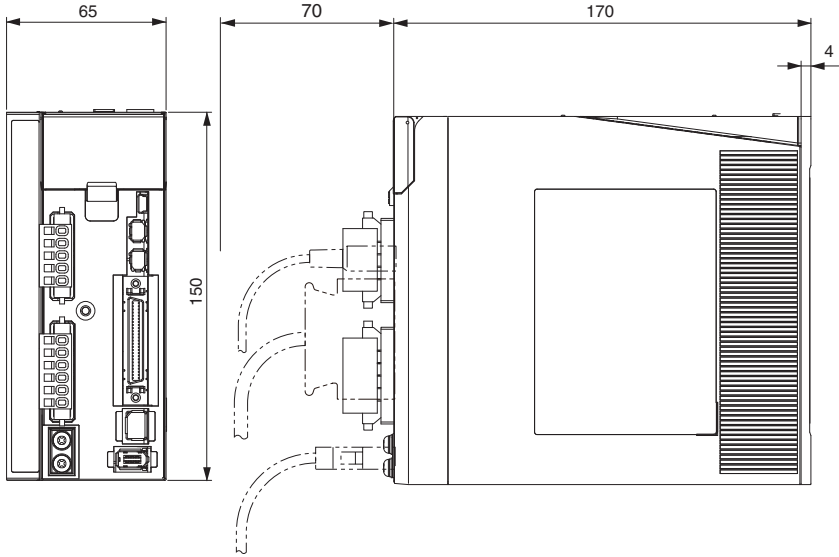

Mounting dimensions

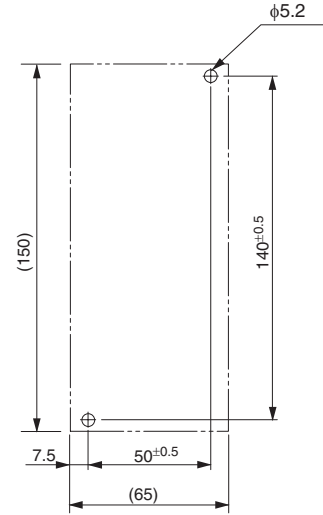

Front Mounting (Using Front Mounting Brackets)

External dimensions

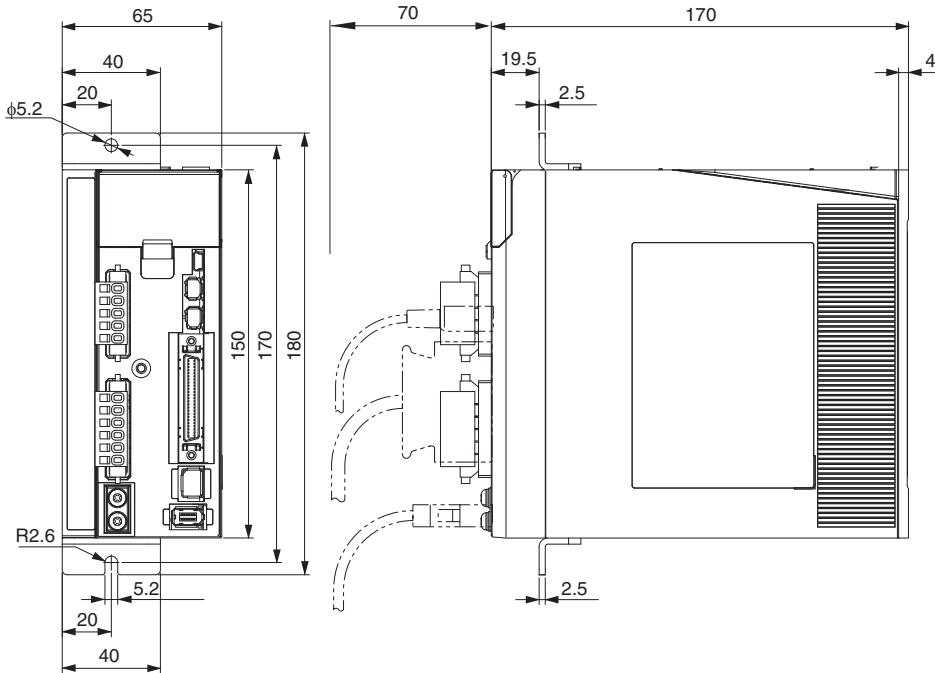

Mounting dimensions

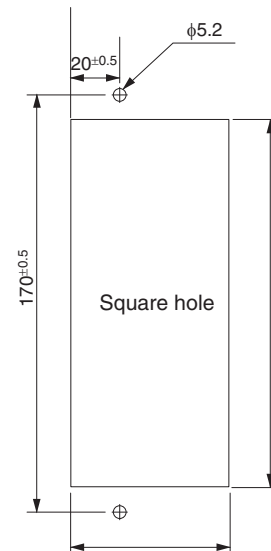

Single-phase/3-phase 200 VAC: R88D-KT10H-L/-KT15H-L (1 kW to 1.5 kW)

Wall Mounting

External dimensions

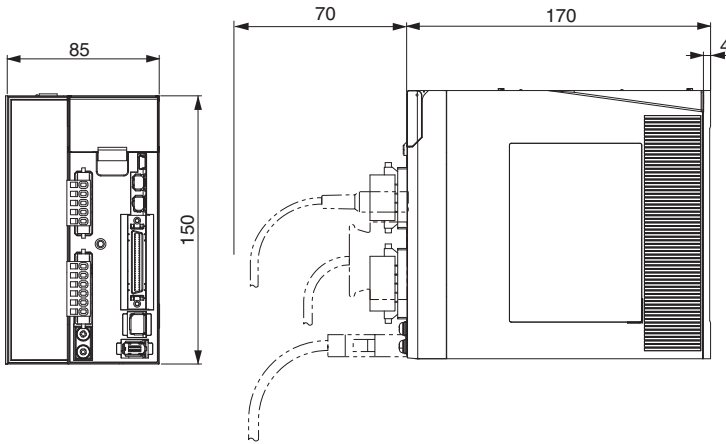

Mounting dimensions

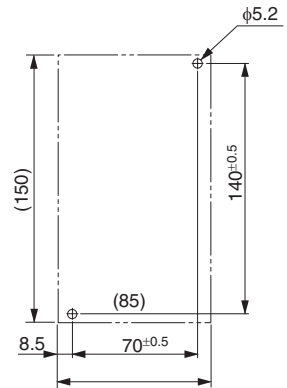

Front Mounting (Using Front Mounting Brackets)

External dimensions

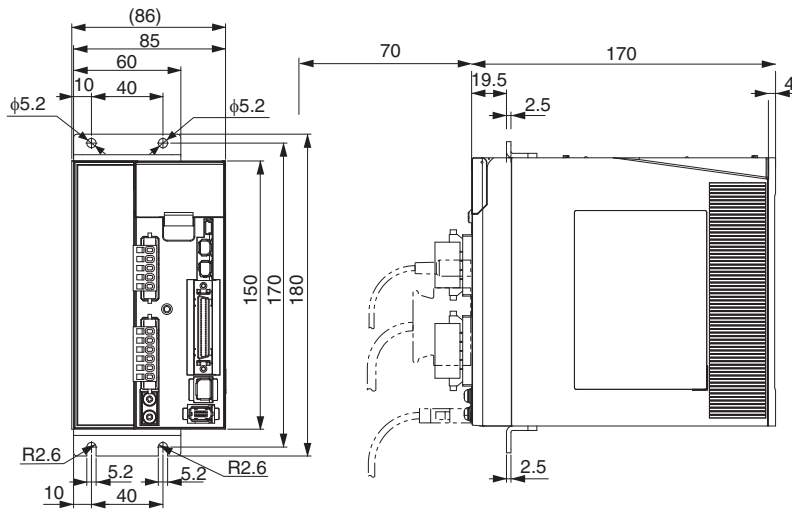

Mounting dimensions

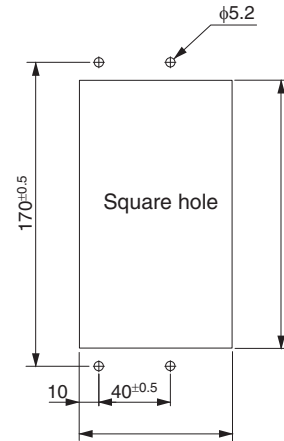

3-phase 200 VAC: R88D-KT20H-L (2 kW)

Wall Mounting

External dimensions

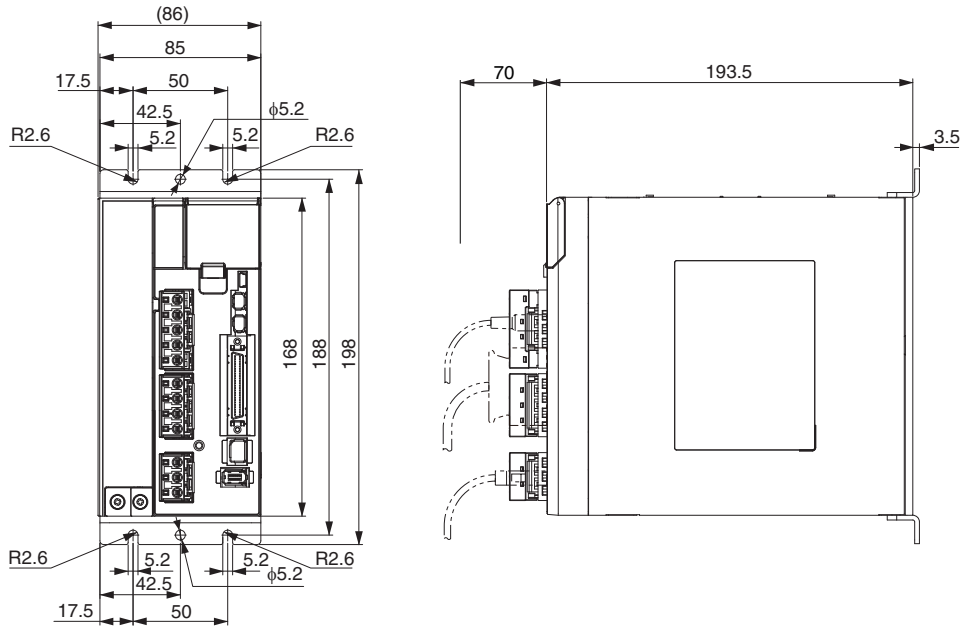

Mounting dimensions

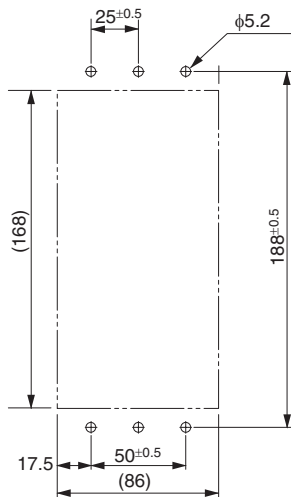

Front Mounting (Using Front Mounting Brackets)

External dimensions

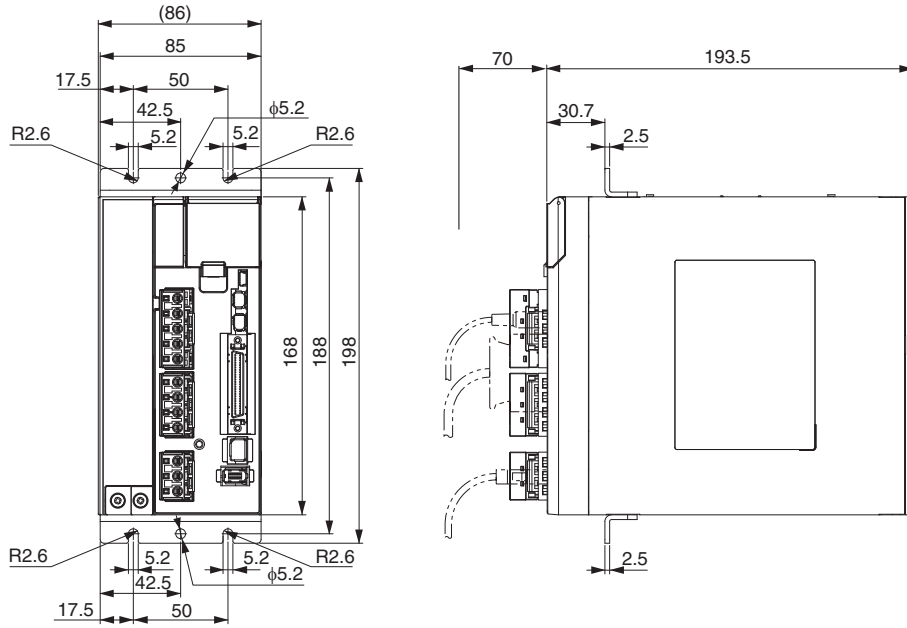

Mounting dimensions

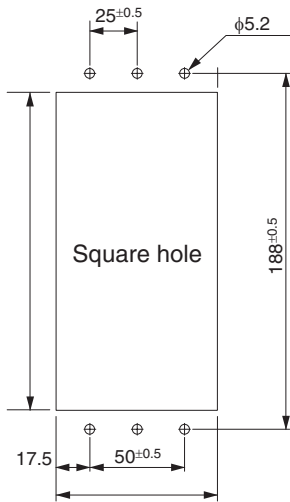

3-phase 400 VAC: R88D-KT20F-L (2 kW)

Wall Mounting

External dimensions

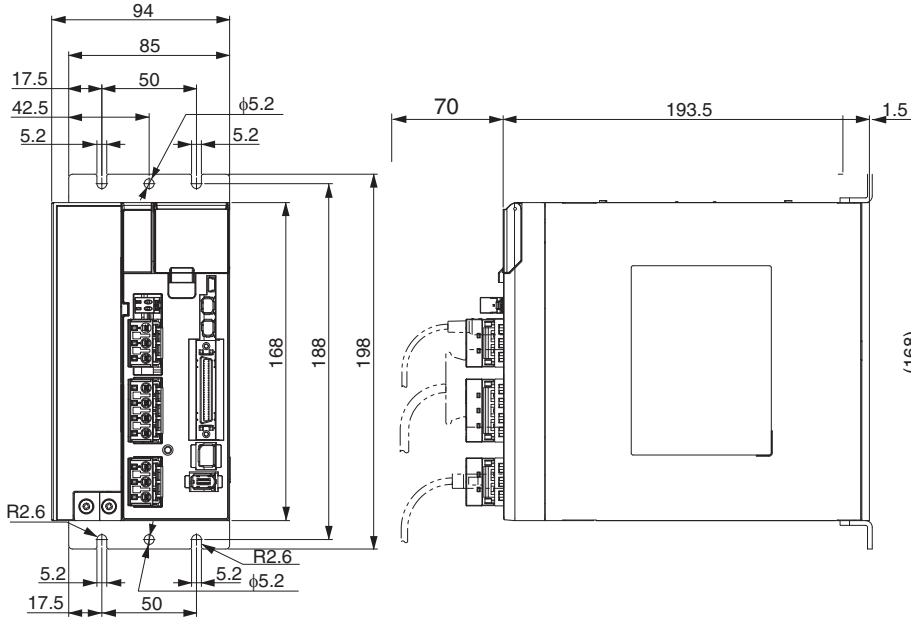

Mounting dimensions

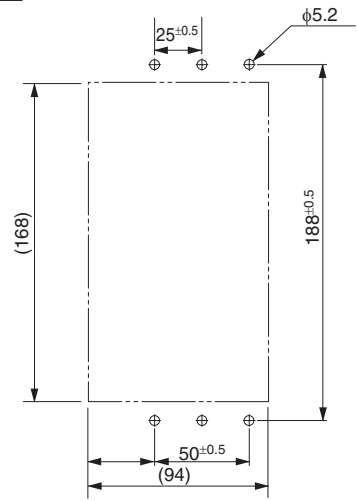

Front Mounting (Using Front Mounting Brackets)

External dimensions

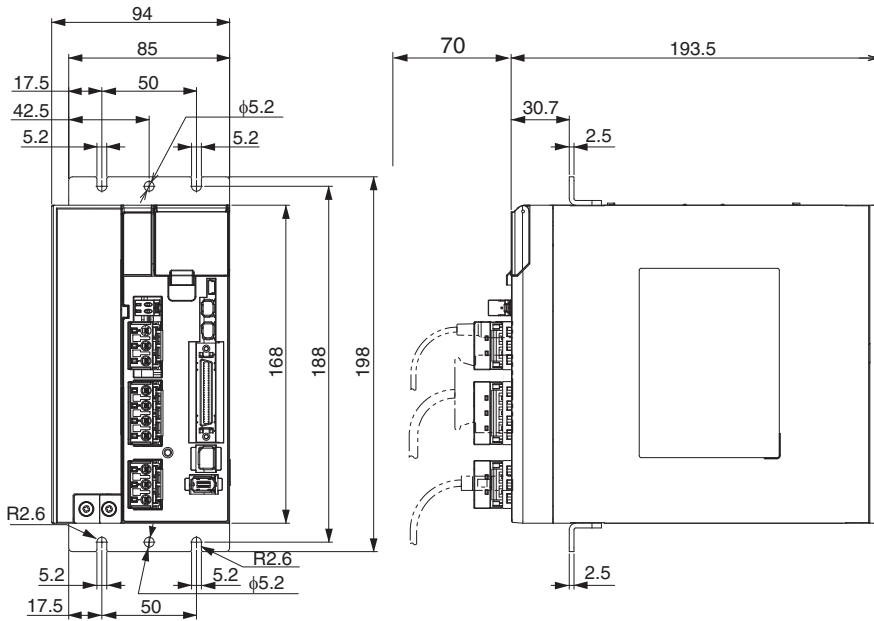

Mounting dimensions

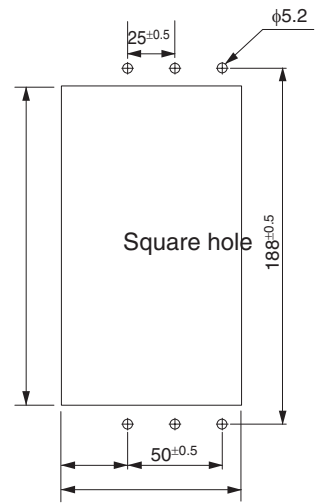

3-phase 400 VAC: R88D-KT30F-L/-KT50F-L (3 to 5 kW)

Wall Mounting

External dimensions

Mounting dimensions

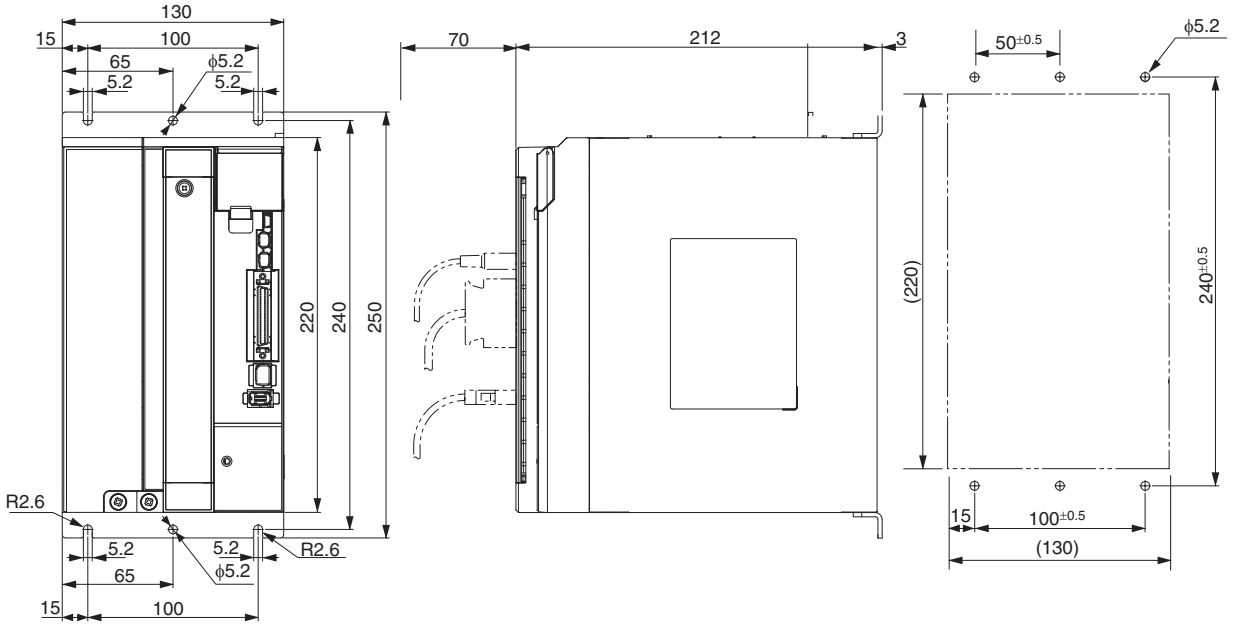

Front Mounting (Using Front Mounting Brackets)

External dimensions

Mounting dimensions

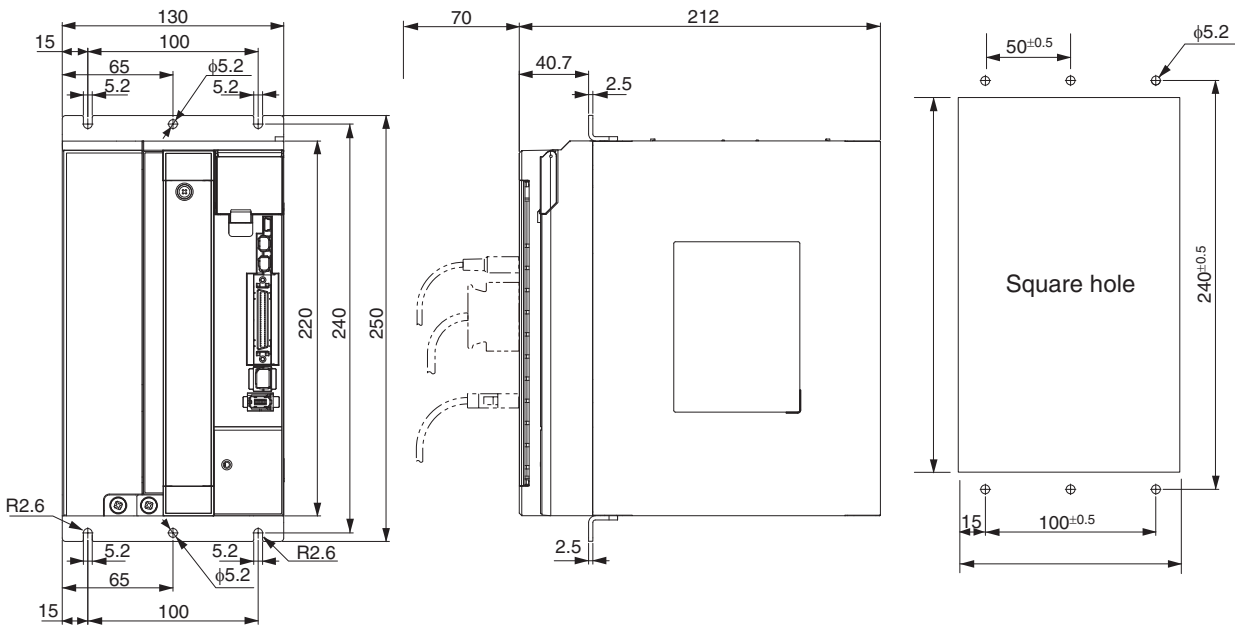

2

Standard Models and External Dimensions

Linear Servomotor Dimensions

Iron-core family

R88L-EC-FW-0303/-0306

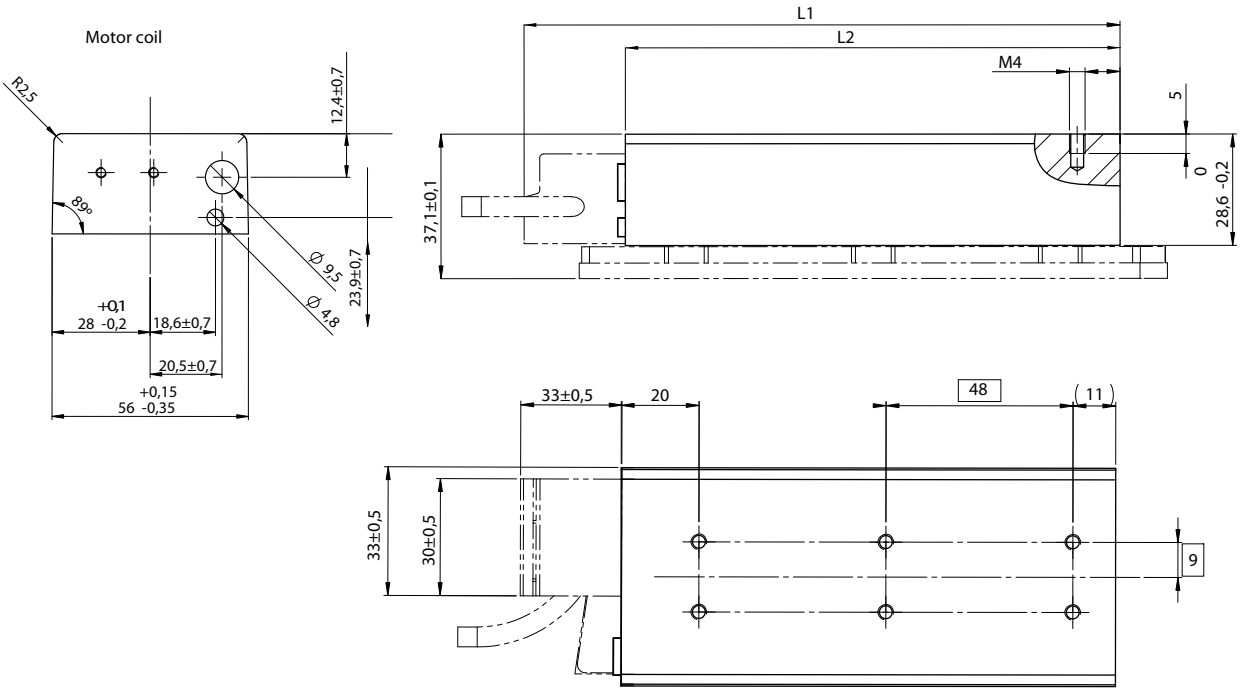

Cable length 500±30
Connector optional
HYPERTAC
LRRA06AMRPN182 (MALE)

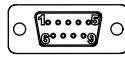

Cable length 500±30
Connector optional
D-Sub 9-pin (FEMALE)

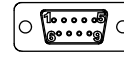

Cable length 500±30
D-Sub 9-pin (FEMALE)

Power		
Pin No.	Wire	Function
1	Black	Phase U
2	Black	Phase V
3	Green/Yellow	Ground
4	Black	Phase W
5	Not used	Not used
6	Not used	Not used

Sensor	
Pin No.	Function
1	Not used
2	Not used
3	Not used
4	Not used
5	Not used
6	PTC
7	PTC
8	KTY/NTC
9	KTY/NTC
Case	Shield

Hall sensor (optional)	
Pin No.	Function
1	5V
2	Hall U
3	Hall V
4	Hall W
5	GND
6	PTC
7	PTC
8	KTY
9	KTY
Case	Shield

Magnet track

Model	L1 (mm)	n	Approx. weight (Kg/m)
R88L-EC-FM-03096-A	96	1	2.1
R88L-EC-FM-03144-A	144	2	
R88L-EC-FM-03384-A	384	7	

Model	Dimensions (mm)	
	L1	L2
R88L-EC-FW0303	105 ±0,5	79 +0,15/-0,35
R88L-EC-FW0306	153 ±0,5	127 +0,15/-0,35

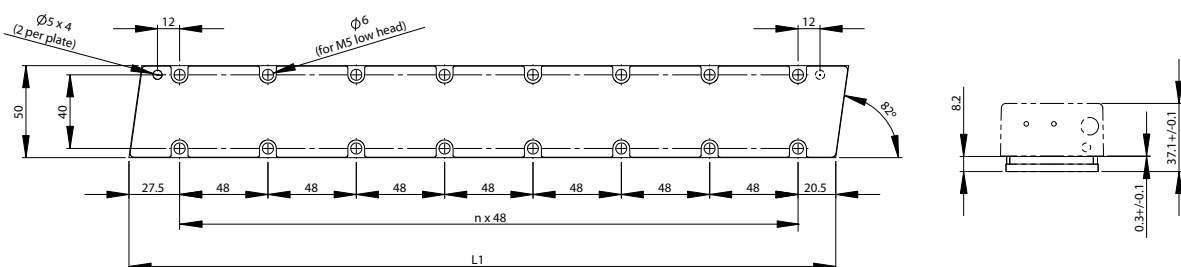

2-4 External and Mounting Dimensions

R88L-EC-FW-0606/-0609/-0612

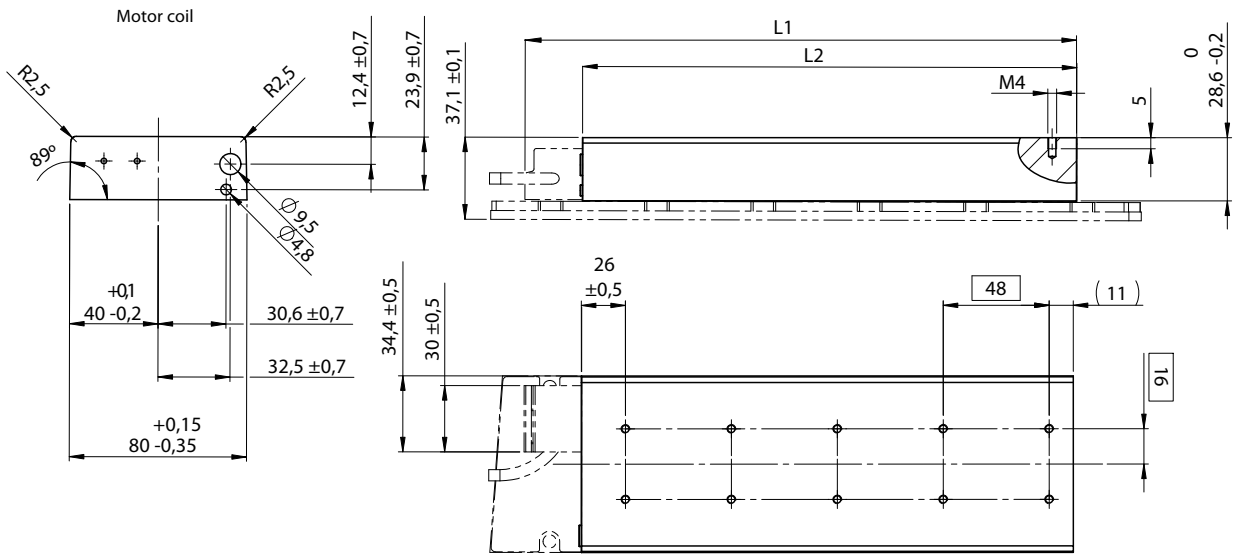

Cable length 500±30
Connector optional
HYPERTAC
LRR06AMRPN182 (MALE)

Power		
Pin No.	Wire	Function
1	Black	Phase U
2	Black	Phase V
3	Green/Yellow	Ground
4	Black	Phase W
5	Not used	Not used
6	Not used	Not used

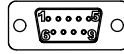

Cable length 500±30
Connector optional
D-Sub 9-pin (FEMALE)

Sensor	
Pin No.	Function
1	Not used
2	Not used
3	Not used
4	Not used
5	Not used
6	PTC
7	PTC
8	KTY/NTC
9	KTY/NTC
Case	Shield

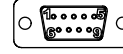

Cable length 500±30
Connector optional
D-Sub 9-pin (FEMALE)

Hall sensor (optional)	
Pin No.	Function
1	5V
2	Hall U
3	Hall V
4	Hall W
5	GND
6	PTC
7	PTC
8	KTY
9	KTY
Case	Shield

Magnet track

Model	L1(mm)	n	Approx. weight (Kg/m)
R88L-EC-FM-06192-A	192	3	3.8
R88L-EC-FM-06288-A	288	5	

Model	Dimensions (mm)	
	L1	L2
R88L-EC-FW0606	153 ± 0.5	127 + 0.15/-0.35
R88L-EC-FW0609	201 ± 0.5	175 + 0.15/-0.35
R88L-EC-FW0612	249 ± 0.5	223 + 0.15/-0.35

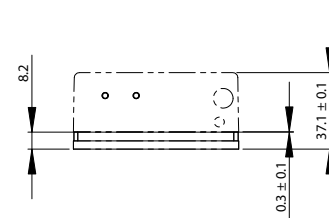
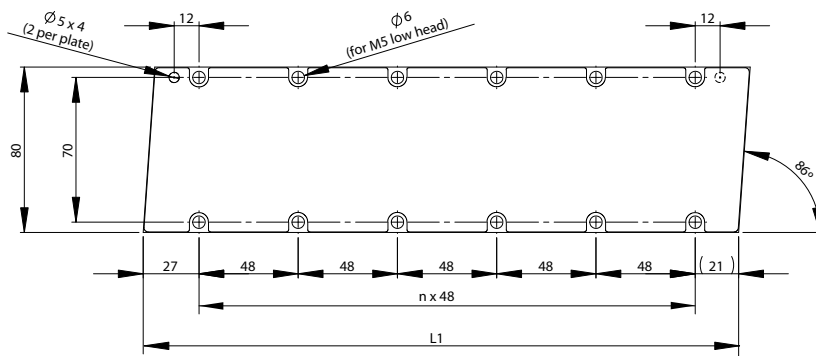

R88L-EC-FW-1112/-1115

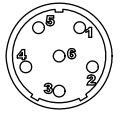
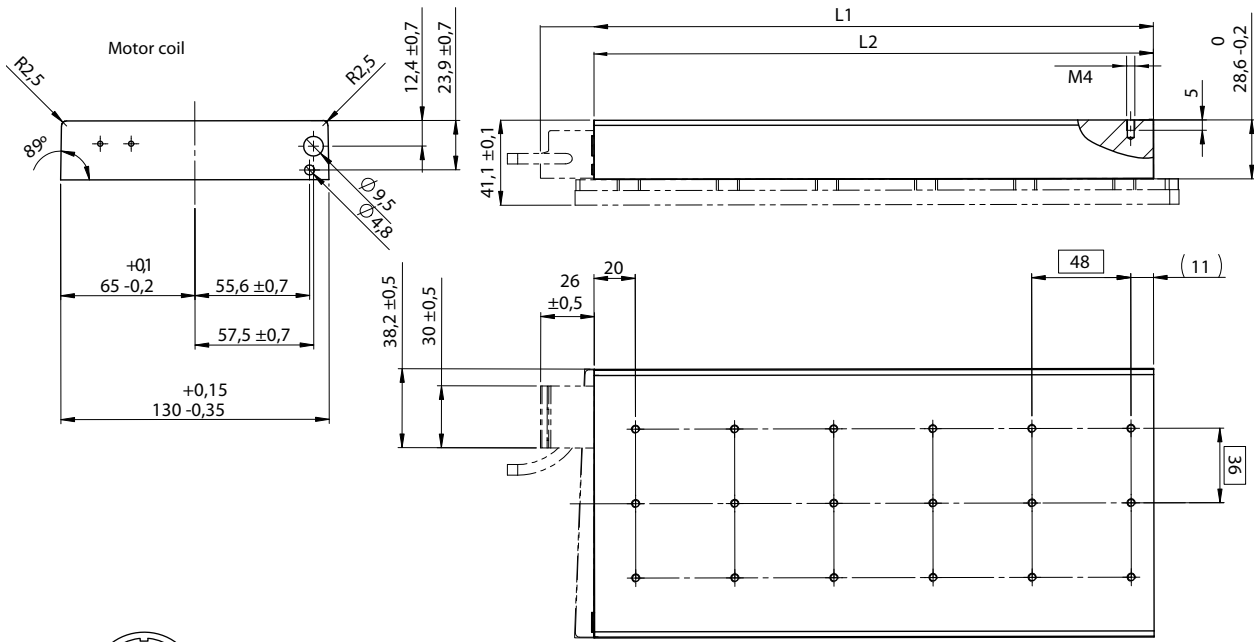

Cable length 500±30
Connector optional
HYPERTAC
LRR06AMRPN182 (MALE)

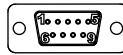

Cable length 500±30
Connector optional
D-Sub 9-pin (FEMALE)

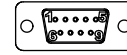

Cable length 500±30
D-Sub 9-pin (FEMALE)

Power		
Pin No.	Wire	Function
1	Black	Phase U
2	Black	Phase V
3	Green/Yellow	Ground
4	Black	Phase W
5	Not used	Not used
6	Not used	Not used

Sensor	
Pin No.	Function
1	Not used
2	Not used
3	Not used
4	Not used
5	Not used
6	PTC
7	PTC
8	KTY/NTC
9	KTY/NTC
Case	Shield

Hall sensor (optional)	
Pin No.	Function
1	5V
2	Hall U
3	Hall V
4	Hall W
5	GND
6	PTC
7	PTC
8	KTY
9	KTY
Case	Shield

Magnet track

Model	L1(mm)	n	Approx. weight (Kg/m)
R88L-EC-FM-06192-A	192	3	3.8
R88L-EC-FM-06288-A	288	5	

Model	Dimensions (mm)	
	L1	L2
R88L-EC-FW1112	249 ±0,5	223 +0,15/-0,35
R88L-EC-FW1115	297 ±0,5	271 +0,15/-0,35

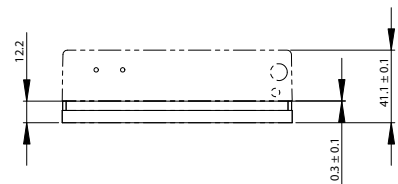
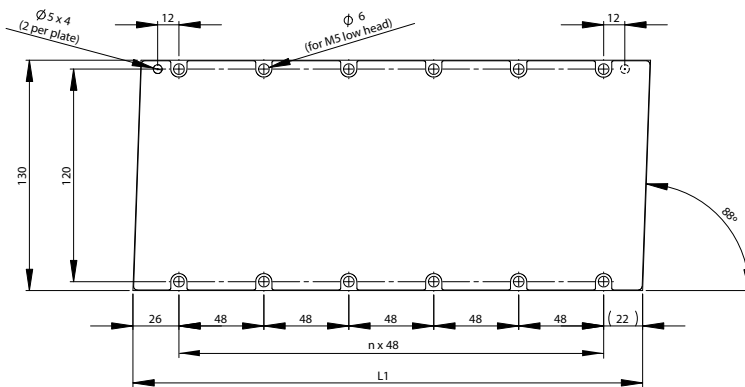

2-4 External and Mounting Dimensions

Hall Sensor Dimensions (for Iron-core motors)

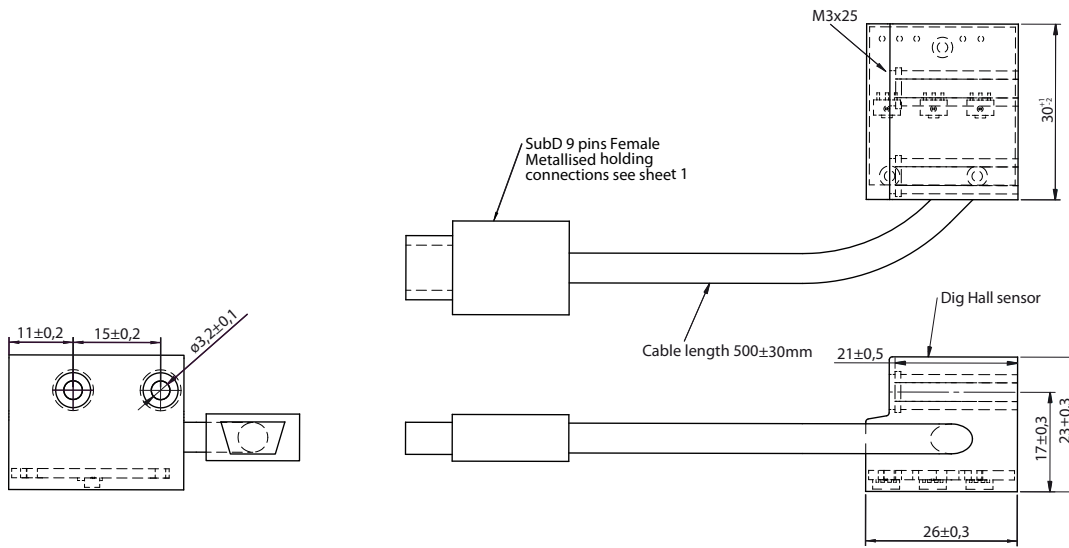

2

Ironless family

R88L-EC-GW-0303/0306/0309

Motor coil

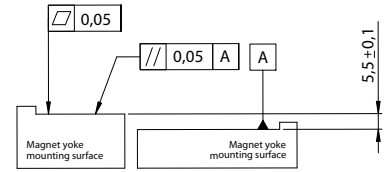
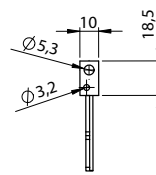
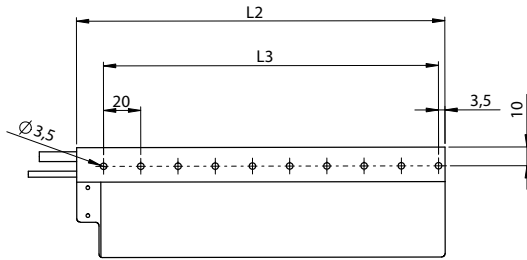

Motor with magnet track (separate order no.)

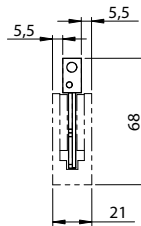
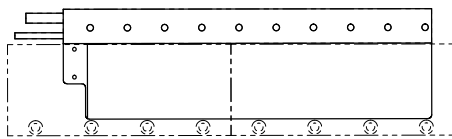

Motor with hall sensor (optional)

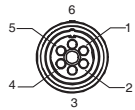
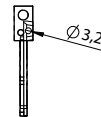
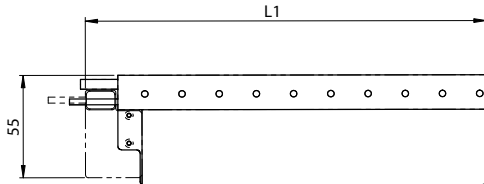

Cable length 1000±30
Connector optional
Made by Hypertac
SROC06JMSCN169 (MALE)
Pin article code: 021.423.1020

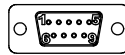

Cable length 500±30
Connector optional
D-Sub 9-pin (FEMALE)

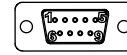

Cable length 500±30
D-Sub 9-pin (FEMALE)

Power connector		
Pin No.	Wire	Function
1	Black-1	Phase U
2	Black-2	Phase V
3	Black-3	Phase W
4	Not used	-
5	Not used	-
6	Green/Yellow	Ground

Mating connector:
Plug type: SPOC06KFSDN169

Sensor	
Pin No.	Function
1	Not used
2	Not used
3	Not used
4	Not used
5	Not used
6	PTC
7	PTC
8	KTY/NTC
9	KTY/NTC
Case	Shield

Hall sensor (optional)	
Pin No.	Function
1	5V
2	Hall U
3	Hall V
4	Hall W
5	GND
6	PTC
7	PTC
8	KTY
9	KTY
Case	Shield

Magnet track

Model	L1 (mm)	n	Approx. weight (Kg/m)
R88L-EC-GM-03090-A	90	2	4.8
R88L-EC-GM-03120-A	120	3	
R88L-EC-GM-03390-A	390	12	

Model	Dimensions (mm)		
	L1	L2	L3
R88L-EC-GW0303	95,4	78	60
R88L-EC-GW0306	155,4	138	100
R88L-EC-GW0309	215,4	198	180

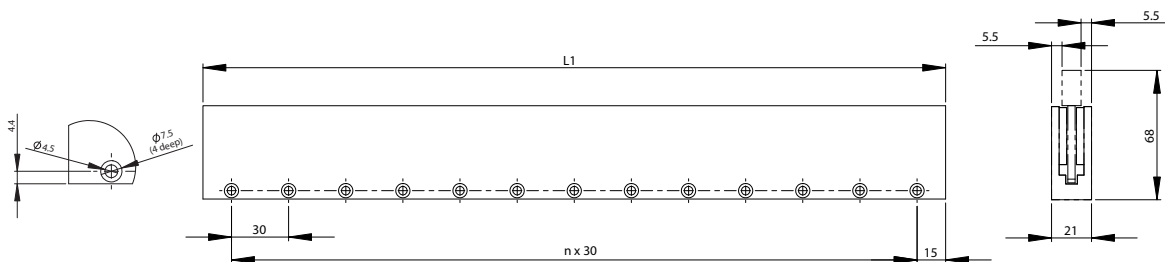

2-4 External and Mounting Dimensions

R88L-EC-GW-0503/-0506/-0509

Motor coil

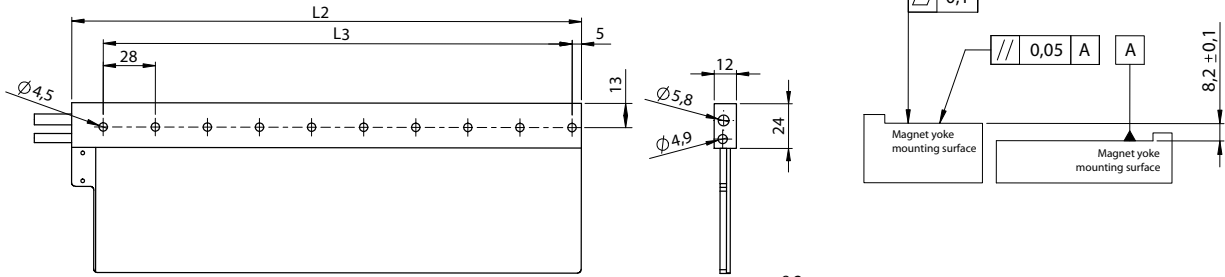

Motor with magnet track (separate order no.)

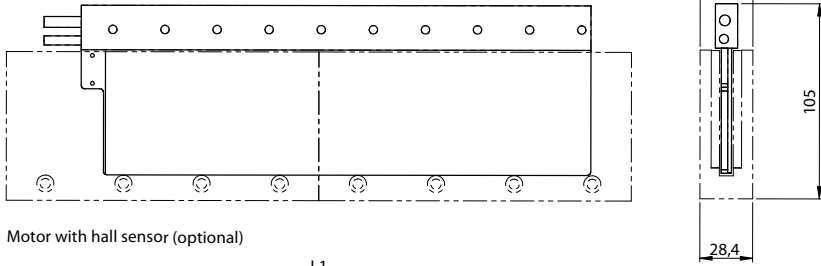

Motor with hall sensor (optional)

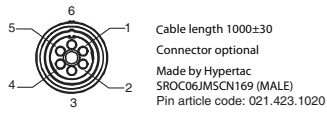
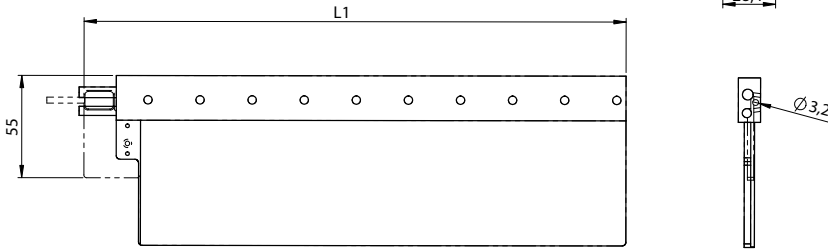

Power connector		
Pin No.	Wire	Function
1	Black-1	Phase U
2	Black-2	Phase V
3	Black-3	Phase W
4	Not used	-
5	Not used	-
6	Green/Yellow	Ground

Mating connector:
Plug type: SPOC06KFSDN169

Sensor	
Pin No.	Function
1	Not used
2	Not used
3	Not used
4	Not used
5	Not used
6	PTC
7	PTC
8	KTY/NTC
9	KTY/NTC
Case	Shield

Hall sensor (optional)	
Pin No.	Function
1	5V
2	Hall U
3	Hall V
4	Hall W
5	GND
6	PTC
7	PTC
8	KTY
9	KTY
Case	Shield

Magnet track

Model	L1(mm)	n	Approx. weight (Kg/m)
R88L-EC-GM-05126-A	126	2	11.2
R88L-EC-GM-05168-A	168	3	
R88L-EC-GM-05210-A	210	4	
R88L-EC-GM-05546-A	546	12	

Model	Dimensions (mm)		
	L1	L2	L3
R88L-EC-GW0503	123,4	106	84
R88L-EC-GW0506	207,4	190	168
R88L-EC-GW0509	291,4	274	252

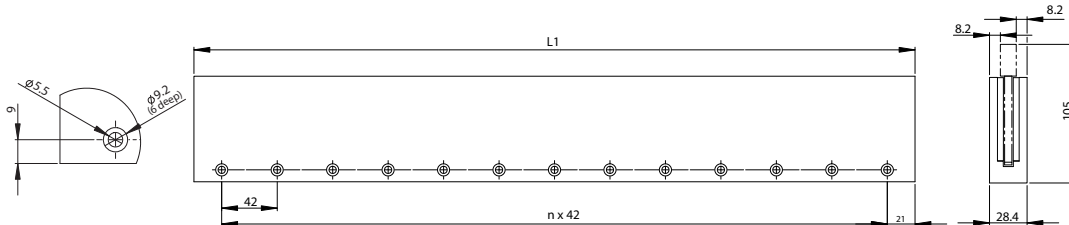

R88L-EC-GW-0703/-0706/-0709

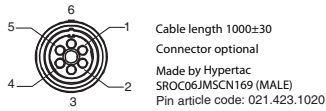
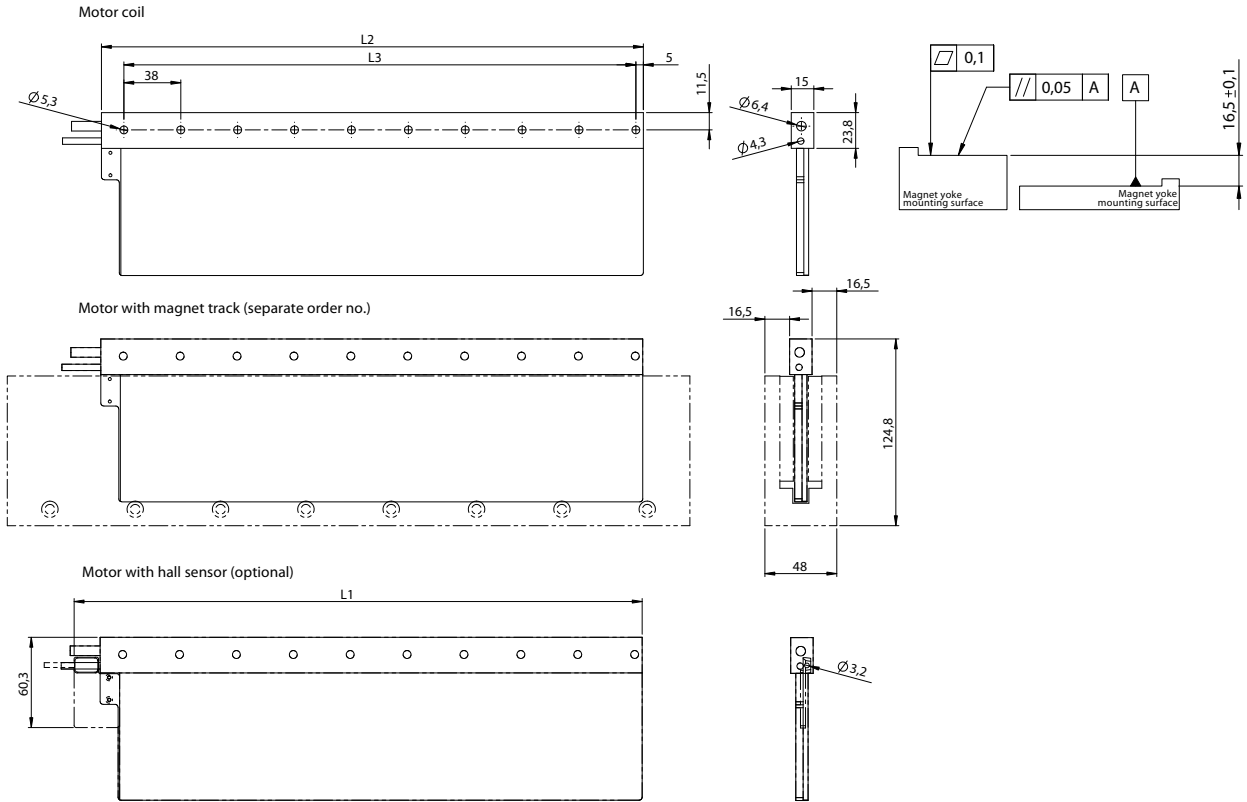

Power connector		
Pin No.	Wire	Function
1	Black-1	Phase U
2	Black-2	Phase V
3	Black-3	Phase W
4	Not used	-
5	Not used	-
6	Green/Yellow	Ground

Mating connector:
Plug type: SPOC06KFSDN169

Sensor	
Pin No.	Function
1	Not used
2	Not used
3	Not used
4	Not used
5	Not used
6	PTC
7	PTC
8	KTY/NTC
9	KTY/NTC
Case	Shield

Hall sensor (optional)	
Pin No.	Function
1	5V
2	Hall U
3	Hall V
4	Hall W
5	GND
6	PTC
7	PTC
8	KTY
9	KTY
Case	Shield

Magnet track

Model	L1 (mm)	n	Approx. weight (Kg/m)
R88L-EC-GM-07114-A	114	1	25.5
R88L-EC-GM-07171-A	171	2	
R88L-EC-GM-07456-A	456	7	

Model	Dimensions (mm)		
	L1	L2	L3
R88L-EC-GW0703	151,4	134	114
R88L-EC-GW0706	265,4	248	228
R88L-EC-GW0709	379,4	362	342

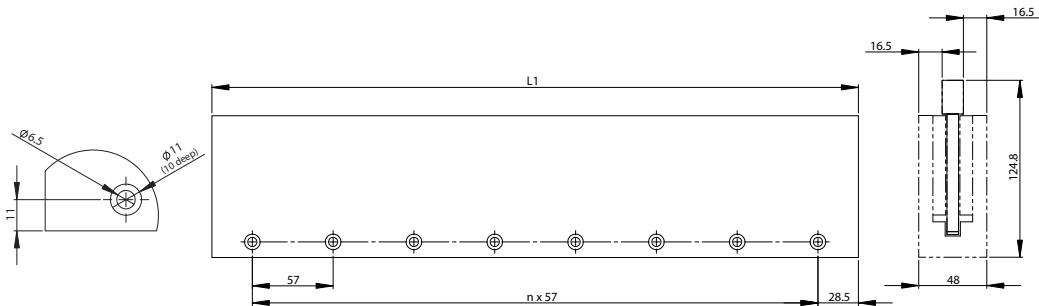

2-4 External and Mounting Dimensions

Hall Sensor Dimensions (for Ironless motors)

R88L-EC-GH03NN-A
R88L-EC-GH05NN-A
R88L-EC-GH07NN-A

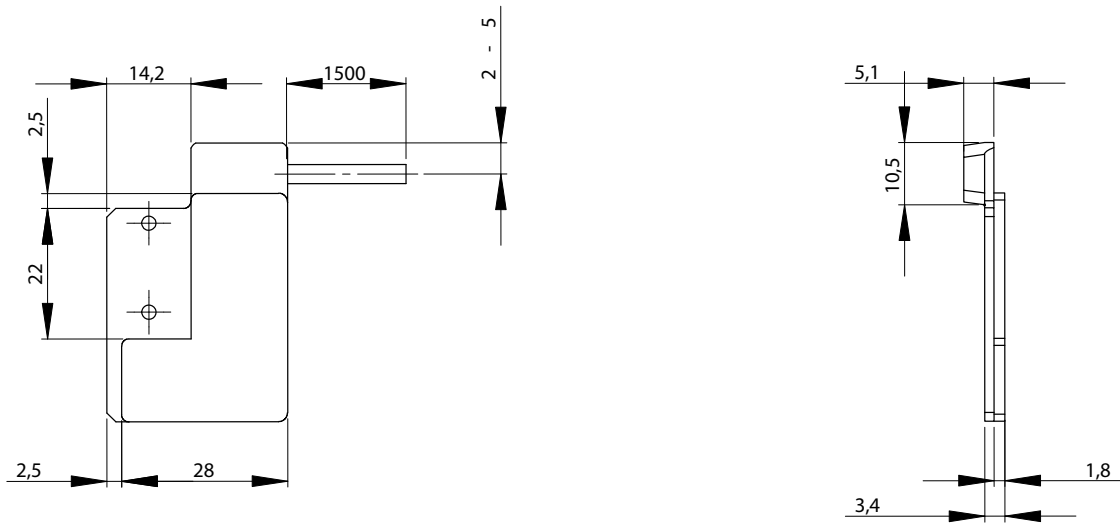

Note: The dimension of the three hall sensor models is the same but the internal distribution of the sensors is different so you must use the suitable model depending on the motor coil used.

Serial Converter Dimensions

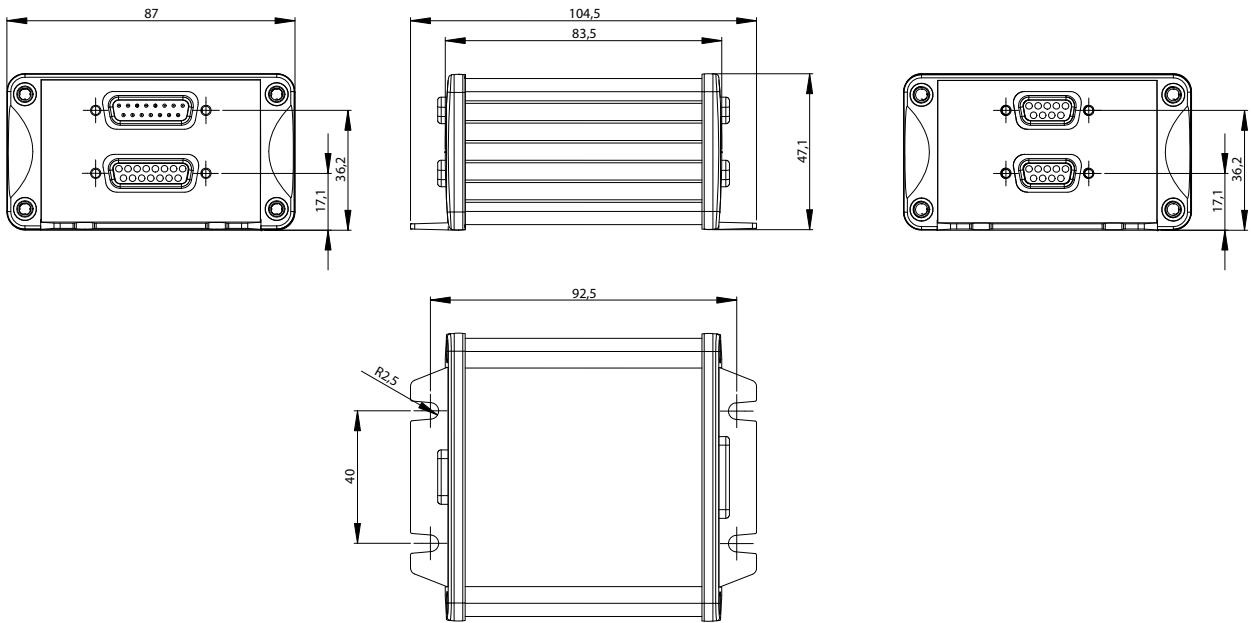

Pinout

Encoder input 1Vpp (CN1)	
Connector D-Sub 15-pin (female) 1Vpp with programmable lines NUMERIK JENA Standard	
PIN	Signal
1	SDA*
2	SCL*
3	-
4	-U ₀
5	-U ₂
6	-U ₁
7	-
8	5V
9	0V
10	-
11	-
12	U ₀
13	U ₂
14	U ₁
15	IS

*Reserved. Please do not use.

2-4 External and Mounting Dimensions

Serial interface (CN4)	
Connector D-Sub 15-pin (male)	
PIN	Signal
1	PS
2	/PS
3	-
4	-
5	-
6	-
7	-
8	5V
9	0V
10	-
11	-
12	-
13	-
14	-
15	-

Hall & Temperature sensors interface (CN2)	
Connector D-Sub 9-pin (female)	
PIN	Signal
1	U+
2	Hall U
3	Hall V
4	Hall W
5	GND
6	PTC
7	PTC
8	KTY
9	KTY

Temperature sensor interface without Hall sensor (CN3)	
Connector D-Sub 9-pin (female)	
PIN	Signal
1	-
2	-
3	-
4	-
5	-
6	PTC
7	PTC
8	KTY/NTC
9	KTY/NTC

2-5 EMC Filter Dimensions

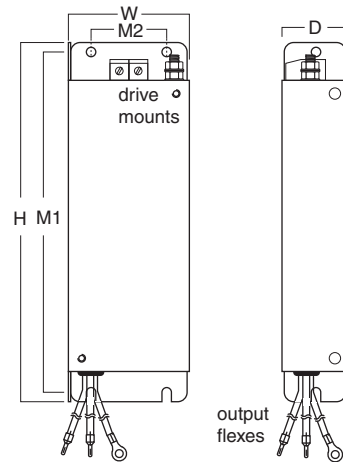

Filter model	External dimensions			Mount dimensions	
	H	W	D	M1	M2
R88A-FIK102-RE	190	42	44	180	20
R88A-FIK104-RE	190	57	30	180	30
R88A-FIK107-RE	190	64	35	180	40
R88A-FIK114-RE	190	86	35	180	60
R88A-FIK304-RE	190	86	40	180	60
R88A-FIK306-RE	245	94	40	235	60
R88A-FIK312-RE	290	130	45	280	100

Specifications

This chapter explains the general specifications, characteristics, connector specifications and I/O circuits of the Servo Drive, Linear Servomotor and peripheral devices.

3-1	Drive Specifications	3-3
	General Specifications	3-3
	Characteristics	3-4
	Main Circuit and Motor Connections	3-9
	Control I/O Connector Specifications (CN1)	3-13
	Control Input Circuits	3-23
	Control Input Details	3-27
	Control Output Circuits.....	3-39
	Control Output Details.....	3-40
	Encoder Connector Specifications (CN4)	3-46
	Monitor Connector Specifications (CN5).....	3-51
	USB Connector Specifications (CN7)	3-52
	Safety Connector Specifications (CN8)	3-53
3-2	Overload Characteristics (Electronic Thermal Function)	
	3-55
	Overload Characteristics Graphs.....	3-55
3-3	Motor Specifications	3-56
	General Specifications for Iron-core motors	3-56
	Characteristics for Iron-core motors.....	3-57
	Speed-Force for Iron-core motors.....	3-60
	Temperature sensor specification for Iron-core motors	3-64
	General Specifications for Ironless motors	3-65
	Characteristics for Ironless motors	3-66
	Speed-Force for Ironless motors	3-69
	Temperature sensor specification for Ironless motors	3-74
3-4	Encoder, Hall sensor and Serial Converter.....	3-76
	A/B Incremental Encoder Specifications	3-76
	SinCos Encoder Specifications	3-79
	Hall Sensor Specifications.....	3-82
	Serial Converter Specifications	3-83

3-5	Cable and Connector Specifications	3-87
	Encoder Cable Specifications	3-87
	Motor Power Cable Specifications	3-91
	Cable for Safety Functions (for CN8)	3-93
	Connector Specifications	3-94
	Analog Monitor Cable Specifications	3-95
	Control Cable Specifications	3-96
3-6	Servo Relay Units and Cable Specifications	3-112
	Servo Relay Units Specifications	3-112
	Position Control Unit-Servo Relay Unit Cable Specifications	3-121
3-7	External Regeneration Resistor Specifications	3-130
	External Regeneration Resistor Specifications	3-130
3-8	EMC Filter Specifications	3-132

3-1 Drive Specifications

Select the Linear Servo Drive matching the Linear Servomotor to be used. Refer to "Linear Servo Drive and Servomotor Combination List"(P.2-9)

The same Accurax G5-Linear AC Servo Drive can be used for either a pulse train input or analog input. You can change the CONTROL mode according to the controller. (The default setting is for position control with pulse train commands.)

General Specifications

Item		Specifications	
Ambient operating temperature and operating humidity		0 to +55C, 90% RH max. (with no condensation)	
Storage ambient temperature and humidity		-20 to +65C, 90% RH max. (with no condensation)	
Operating and storage atmosphere		No corrosive gases	
Vibration resistance		10 to 60 Hz and at an acceleration of 5.88 m/s ² or less (Not to be run continuously at the resonance point)	
Impact resistance		Acceleration of 19.6 m/s ² max. 2 times each in X, Y, and Z directions	
Insulation resistance		Between power supply terminal/power terminal and FG terminal: 0.5 MΩ min. (at 500 VDC Megger)	
Dielectric strength		Between power supply/power line terminals and FG terminal: 1,500 VAC for 1 min at 50/60 Hz	
Protective structure		Built into panel	
International standard	EC directive	EMC directive	EN 55011, EN 61000-6-2, IEC 61800-3
		Low voltage command	EN 61800-5-1
	UL standards		UL 508C
	CSA standards		CSA22.2 No. 14
	Functional safety		EN ISO13849-1:2008 (Performance Level d), IEC61800-5-2:2007 (STO), EN61508:2001 (SIL2),EN954-1:1996 (CAT3)

Note 1. The above items reflect individual evaluation testing. The results may differ under compound conditions.

Note 2. Never perform dielectric strength or other megameter tests on the Linear Servo Drive. Failure to follow this guideline may result in damaging the internal elements.

Note 3. Depending on the operating conditions, some Linear Servo Drive parts will require maintenance.

Characteristics

100-VAC Input Type

Item			R88D-KT01L-L	R88D-KT02L-L		R88D-KT04L-L	
PWM frequency			12KHz	6KHz	12KHz	6KHz	12KHz
Continuous Output current			1,7A	2,5A	1,7A	4,6A	2,5A
Peak output current			5,1A	7,5A	5,1A	13,8A	7,5A
Input power supply	Main circuit	Power	100W	200W		400W	
		Voltage	Single-phase 100 to 115V AC (85 to 127V) 50/60Hz				
		Current	7,5A	10A		20A	
	Control circuit	Power supply voltage	Single-phase 100 to 115V AC (85 to 127V) 50/60Hz				
Power losses (At 6KHz)			16,6W	21W		25W	
Control losses			6W	6W		6W	
Weight			Approx. 0,8Kg	Approx. 1.0Kg		Approx. 1.6Kg	
Control method			All-digital servo				
Inverter method			IGBT-driven PWM method				
Applicable Linear servomotor			R88L-EC-FW-0303 R88L-EC-GW-0303 R88L-EC-GW-0503	R88L-EC-FW-0306 R88L-EC-GW-0506 R88L-EC-GW-0703	R88L-EC-FW-0606 R88L-EC-GW-0306 R88L-EC-GW-0509 R88L-EC-GW-0706		

200-VAC Input Type

Item		R88D-KT02H-L		R88D-KT04H-L		R88D-KT08H-L		R88D-KT10H-L	
PWM frequency		6KHz	12KHz	6KHz	12KHz	6KHz	12KHz	6KHz	12KHz
Continuous Output current		-	1,63A	2,6A	1,5A	4A	2,4A	5,6A	4,1A
Peak output current		-	4,89A	7,8A	4,5A	12A	7,2A	16,8A	12,3A
Input power supply	Main circuit	Power	200W		400W		800W		1kW
		Voltage	Single-phase or 3-phase 200 to 240V AC (170 to 264V) 50/60Hz						
	Control circuit	Power supply voltage	Single-phase 200 to 240V AC (170 to 264V) 50/60Hz						
Power losses (At 6KHz)		23/19W*		30/22W*		30/35.5W*		63/64W*	
Control losses		6W		6W		6W		8W	
Weight		Approx. 0,8Kg		Approx. 1,1Kg		Approx. 1,6Kg		Approx. 1,8Kg	
Control method		All-digital servo							
Inverter method		IGBT-driven PWM method							
Applicable Linear servomotor		R88L-EC-FW-0303 R88L-EC-GW-0303		R88L-EC-FW-0306 R88L-EC-GW-0506 R88L-EC-GW-0703		R88L-EC-FW-0606 R88L-EC-GW-0306 R88L-EC-GW-0509 R88L-EC-GW-0706		R88L-EC-FW-0609 R88L-EC-GW-0309 R88L-EC-GW-0709	

*Note: The left value is for single-phase input and the right value is for 3-phase input.

3-1 Drive Specifications

Item		R88D-KT15H-L		R88D-KT20H-L	
PWM frequency		6KHz	12KHz	6KHz	12KHz
Continuous Output current		9,5A	5,7A	13,4A	9,5A
Peak output current		28,5A	17A	40,2A	28,5A
Input power supply	Main circuit	Power	1,5kW		2kW
		Voltage	Single-phase or 3-phase 200 to 240V AC (170 to 264V) 50/60Hz		3-phase 200 to 230V AC (170 to 253V) 50/60Hz
		Current	40A		64A
	Control circuit	Power supply voltage	Single-phase 200 to 240V AC (170 to 264V) 50/60Hz		Single-phase 200 to 230V AC (170 to 253V) 50/60Hz
Power losses (At 6KHz)		104/93W*		139W	
Control losses		8W		10W	
Weight		Approx. 1,8Kg		Approx. 2,7Kg	
Control method		All-digital servo			
Inverter method		IGBT-driven PWM method			
Applicable Linear servomotor		R88L-EC-FW-0612 R88L-EC-FW-1112		R88L-EC-FW-1115	

3

Specifications

400-VAC Input Type

Item			R88D-KT06F-L		R88D-KT10F-L		R88D-KT15F-L		R88D-KT20F-L		R88D-KT30F-L		R88D-KT50F-L	
PWM frequency			6KH z	12K Hz	6KH z	12K Hz	6KHz	12KH z	6KHz	12KH z	6KHz	12KH z	6KHz	12KH z
Continuous Output current			1,5A	1,5A	2,8A	1,5A	4,7A	2,8A	5,9A	4,7A	9,2A	5,9A	16,5 A	9,2A
Peak output current			4,5A	4,5A	8,4A	4,5A	14,1 A	8,4A	17,7 A	14,1 A	27,6 A	17,7 A	49,5 A	27,6 A
Input power supply	Main circuit	Power	600W		1kW		1,5kW		2kW		3kW		5kW	
		Voltage	3-phase 380 to 480V AC (323 to 528V) 50/60Hz											
		Current	7,5A		12A		20A		30A		40A		64A	
	Control circuit	Power supply voltage	24V DC (20,4 to 27,6V)											
Power losses (At 6KHz)			31,2W		48W		49W		65W		108W		200W	
Control losses			9,6w		9,6W		9,6W		12W		12W		12W	
Weight			Approx. 1,9Kg		Approx. 1,9Kg		Approx. 1,9Kg		Approx. 2,7Kg		Approx. 4,7Kg		Approx. 4,7Kg	
Control method			All-digital servo											
Inverter method			IGBT-driven PWM method											
Applicable Linear servomotor			R88L-EC-FW-0303		R88L-EC-FW-0303 R88L-EC-FW-0306		R88L-EC-FW-0606		R88L-EC-FW-0609		R88L-EC-FW-0612 R88L-EC-FW-1112		R88L-EC-FW-1115	

Protective Functions

Error detection	Description
Control power supply undervoltage	The DC voltage of the main circuit fell below the specified value while the operation command (RUN) input was ON.
Overvoltage	The DC voltage in the main circuit is abnormally high.
Main power supply undervoltage	The DC voltage of the main circuit is low.
Overcurrent	Overcurrent flowed to the IGBT. Motor power line ground fault or short circuit.
Drive overheat	The temperature of the drive radiator exceeded the specified value.
Overload	Operation was performed with force significantly exceeding the rating for several seconds to several tens of seconds.
Error counter overflow	The number of accumulated pulses in the error counter exceeded the set value for the Error Counter Overflow Level (Pn014).
Overspeed	The motor movement speed exceeded the maximum number of movements.
Electronic gear setting error	The set value for the Electronic Ratio (Pn009 to Pn010, Pn500 to Pn503) is not appropriate.
Error counter overflow	Error counter value based on the encoder pulse reference exceeded 2^{29} (536870912).
Interface I/O setting error	An error was detected in the interface I/O signal.
Overrun limit error	The motor exceeded the allowable operating range set in the Overrun Limit Setting (Pn514) with respect to the position command input.
Parameter error	Data in the Parameter Save area was corrupted when the power supply was turned ON and data was read from the EEPROM.
Parameters destruction	The checksum for the data read from the EEPROM when the power supply was turned ON does not match.
Drive prohibition input error	The forward drive prohibition and reverse drive prohibition inputs are both turned OFF.
Excessive analog input	A current exceeding the Excessive Analog Input (Pn424, Pn427 or Pn430) was applied to the analog command input (pin 14).
Scale communications error	An error was detected in scale connection and communications data.
Scale status error	An scale error code was detected.
Phases-A, B and Z connection error	An error was generated for connection of phases A, B, and Z of external scale.

Main Circuit and Motor Connections

When wiring the main circuit, use proper wire sizes, grounding systems, and noise resistance.

R88D-KT[][]H/L-L

R88D-KT01L-L/-02L-L/-04L-L/-02H-L/-04H-L/-08H-L/-10H-L/-15H-L

Main Circuit Connector Specifications (CNA)

Symbol	Name	Function
L1	Main circuit power supply input	R88D-KTxL-L (100 to 400 W) : Single-phase 100 to 115 VAC (85 to 127 V) 50/60 Hz (200 to 400 W) : 3-phase: 200 to 240 VAC (170 to 264 V) 50/60 Hz R88D-KTxH-L (200 W to 1.5 kW) : Single-phase: 200 to 240 VAC (170 to 264 V) 50/60 Hz (200 W to 1.5 kW) : 3-phase: 200 to 240 VAC (170 to 264 V) 50/60 Hz Note. Single-phase should connect to L1 and L3.
L2		
L3		
L1C	Control circuit power supply input	R88D-KTxL-L: Single-phase 100 to 115 VAC (85 to 127 V) 50/60 Hz
L2C		R88D-KTxH-L Single-phase 200 to 240 VAC (170 to 264 V) 50/60 Hz

Motor Connector Specifications (CNB)

Symbol	Name	Function
B1	External Regeneration Resistor connection terminals	Normally B2 and B3 are short-circuited. If there is high regenerative energy, remove the short-circuit bar between B2 and B3 and connect an External Regeneration Resistor between B1 and B2. (Models from 750 W)
B2		
B3		
U	Motor connection terminals	Phase U
V		Phase V
W		Phase W
		These are the output terminals to the Linear Servomotor. Be sure to wire them correctly.



Precautions for Correct Use

- ◆ Tighten the ground screws to the force of 0.7 to 0.8 N•m (M4) or 1.4 to 1.6 N•m (M5).

R88D-KT20H-L

Main Circuit Connector Specifications (CNA)

Symbol	Name	Function
L1	Main circuit power supply input	R88D-KTxH-L (2 kW) : 3-phase: 200 to 230 VAC (170 to 253 V) 50/60 Hz
L2		
L3		
L1C	Control circuit power supply input	R88D-KTxH-L : Single-phase 200 to 230 VAC (170 to 253 V) 50/60 Hz
L2C		

Motor Connector Specifications (CNB)

Symbol	Name	Function	
U	Motor connection terminals	Phase U	These are the output terminals to the Linear Servomotor. Be sure to wire them correctly.
V		Phase V	
W		Phase W	

External Regenerative Resistor (CNC)

Symbol	Name	Function
B1	External Regeneration Resistor connection terminals	Normally B2 and B3 are short-circuited. If there is high regenerative energy, remove the short-circuit bar between B2 and B3 and connect an External Regeneration Resistor between B1 and B2.
B2		
B3		
NC		Do not connect.



Precautions for Correct Use

- ♦ Tighten the ground screws to the force of 0.7 to 0.8 N•m (M4) or 1.4 to 1.6 N•m (M5).

R88D-KT06F-L/-KT10F-L/-15F-L/-20F-L**Main Circuit Connector Specifications (CNA)**

Symbol	Name	Function
L1	Main circuit power supply input	R88D-KTxF-L (600 W to 2 kW) : 3-phase: 380 to 480 VAC (323 to 528 V) 50/60 Hz
L2		
L3		

Motor Connector Specifications (CNB)

Symbol	Name	Function	
U	Motor connection terminals	Phase U	These are the output terminals to the Linear Servomotor. Be sure to wire them correctly.
V		Phase V	
W		Phase W	

External Regenerative Resistor (CNC)

Symbol	Name	Function
B1	External Regeneration Resistor connection terminals	Normally B2 and B3 are short-circuited. If there is high regenerative energy, remove the short-circuit bar between B2 and B3 and connect an External Regeneration Resistor between B1 and B2.
B2		
B3		
NC		Do not connect.

Control Circuit Connector Specifications (CND)

Symbol	Name	Function
24 V	Control circuit power supply input	24 VDC \pm 15%
0 V		

**Precautions for Correct Use**

- ◆ Tighten the ground screws to the force of 0.7 to 0.8 N•m (M4) or 1.4 to 1.6 N•m (M5).

R88D-KT30F-L/-50F-L

Terminal Block Specifications (TB1)

Symbol	Name	Function
24 V	Control circuit power supply input	24 VDC ± 15%
0 V		

Terminal Block Specifications (TB2)

Symbol	Name	Function	
L1	Main circuit power supply input	R88D-KTxH-L (3 to 5 kW): 3-phase 200 to 230 VAC (170 to 253 V) 50/60 Hz	
L2			
L3			
B1	External Regeneration Resistor connection terminals	Normally B2 and B3 are short-circuited. If there is high regenerative energy, remove the short-circuit bar between B2 and B3 and connect an External Regeneration Resistor between B1 and B2.	
B2			
B3			
NC		Do not connect.	
U	Motor connection terminals	Phase U	These are the output terminals to the Linear Servomotor. Be sure to wire them correctly.
V		Phase V	
W		Phase W	



Precautions for Correct Use

- ♦ Tighten the terminal block screws to the force of 0.75 N•m (M4) or 1.5 N•m (M5).
- ♦ If the force for terminal block screws exceeds 1.2 N•m (M4) or 2.0 N•m (M5), the terminal block may be damaged.
- ♦ Tighten the fixing screw of the terminal block cover to the force of 0.2 N•m (M3).
- ♦ Tighten the ground screws to the force of 0.7 to 0.8 N•m (M4) or 1.4 to 1.6 N•m (M5).

Control I/O Connector Specifications (CN1)

Control I/O Signal Connections and External Signal Processing for Position Control

This is the configuration with factory settings:

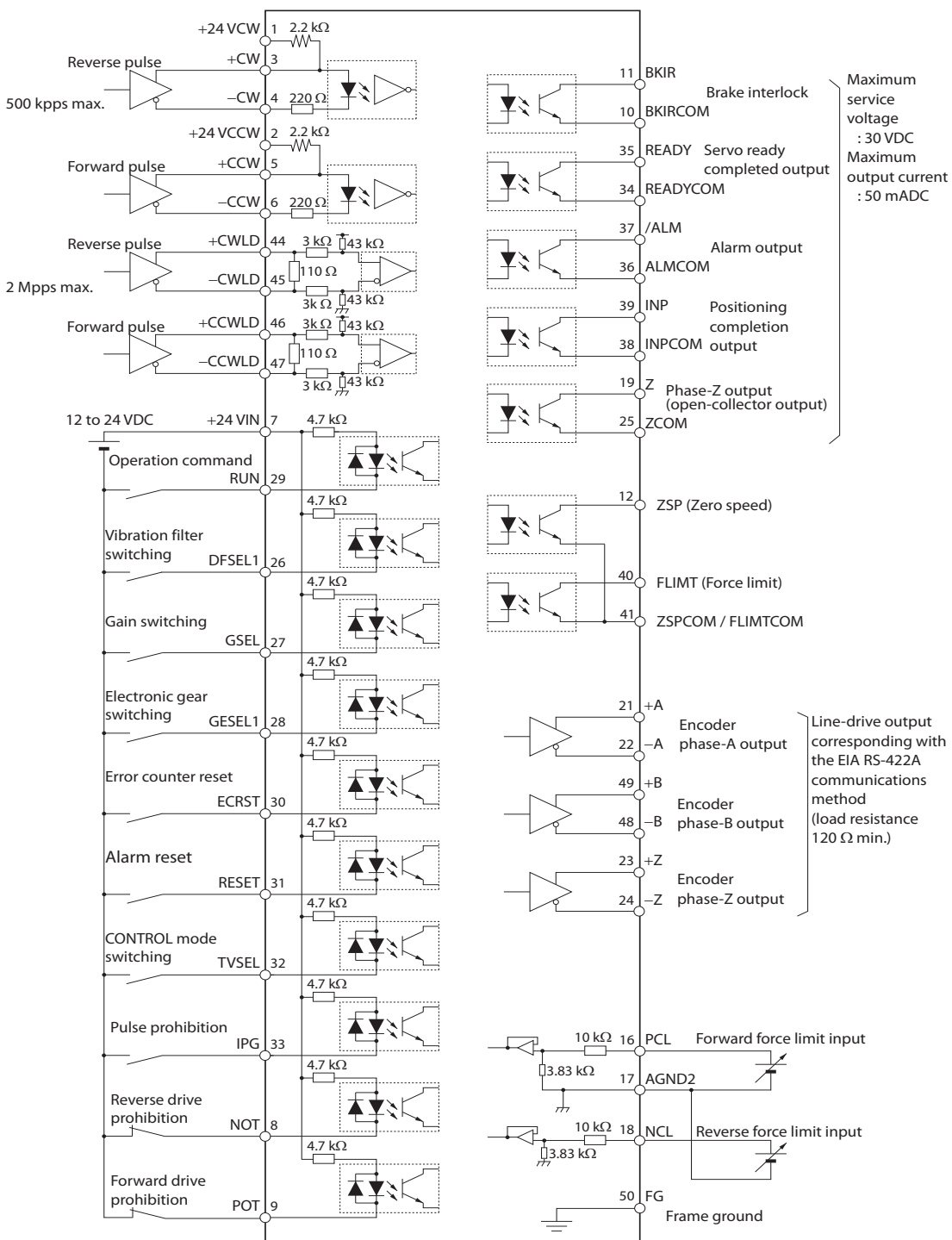

Maximum service voltage : 30 VDC
Maximum output current : 50 mADC

Line-drive output corresponding with the EIA RS-422A communications method (load resistance 120 Ω min.)

Note 1. The inputs of pins 8, 9 and 26 to 33, and outputs of pins 10, 11, 12, 34, 35, 38, 39 and 40 can be changed via parameter settings.

Specifications

Control I/O Signal Connections and External Signal Processing for Speed Control

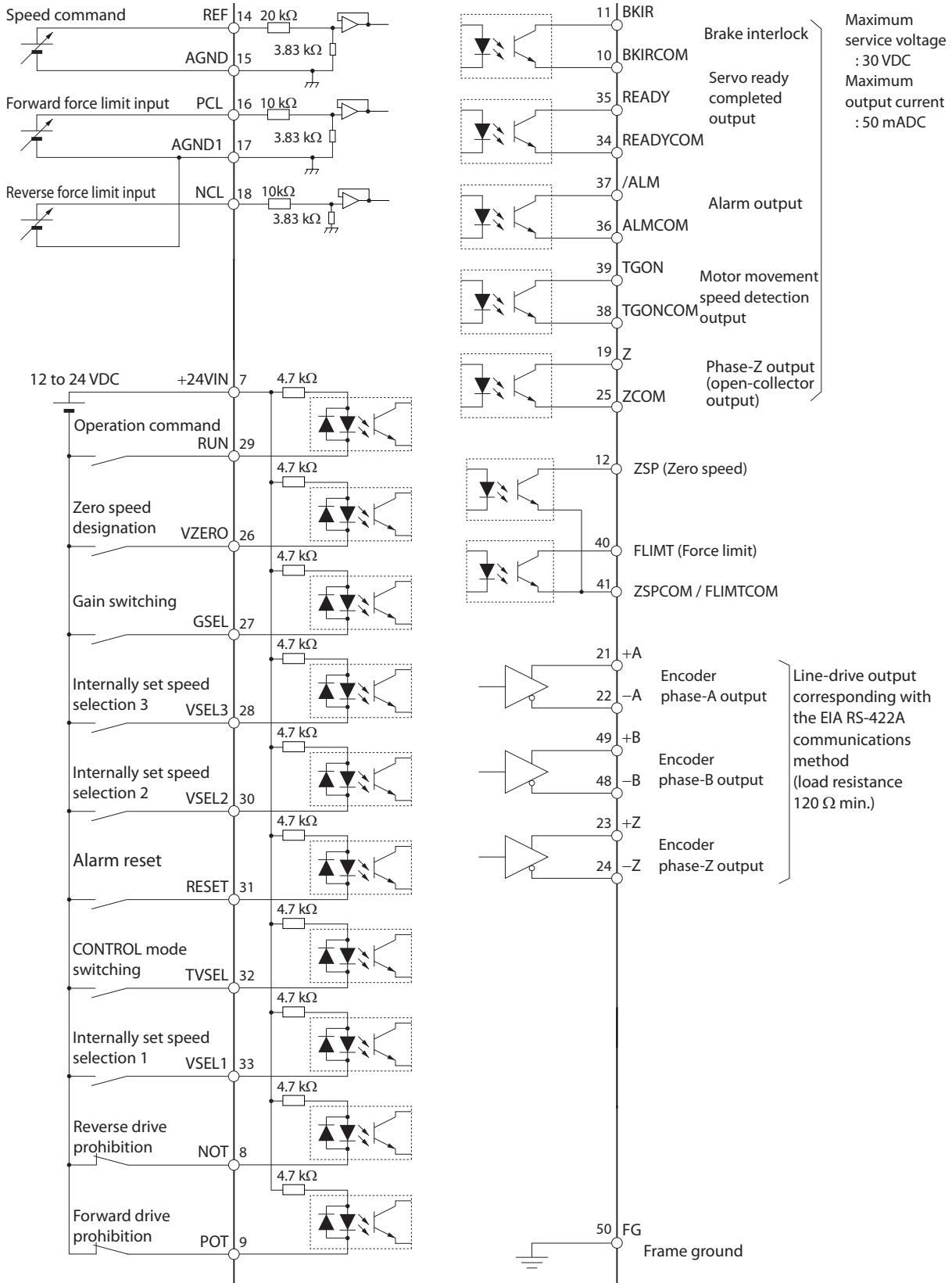

Note 1. The inputs of pins 8, 9 and 26 to 33, and outputs of pins 10, 11, 12, 34, 35, 38, 39 and 40 can be changed via parameter settings.

Specifications

Control I/O Signal Connections and External Signal Processing for Force Control

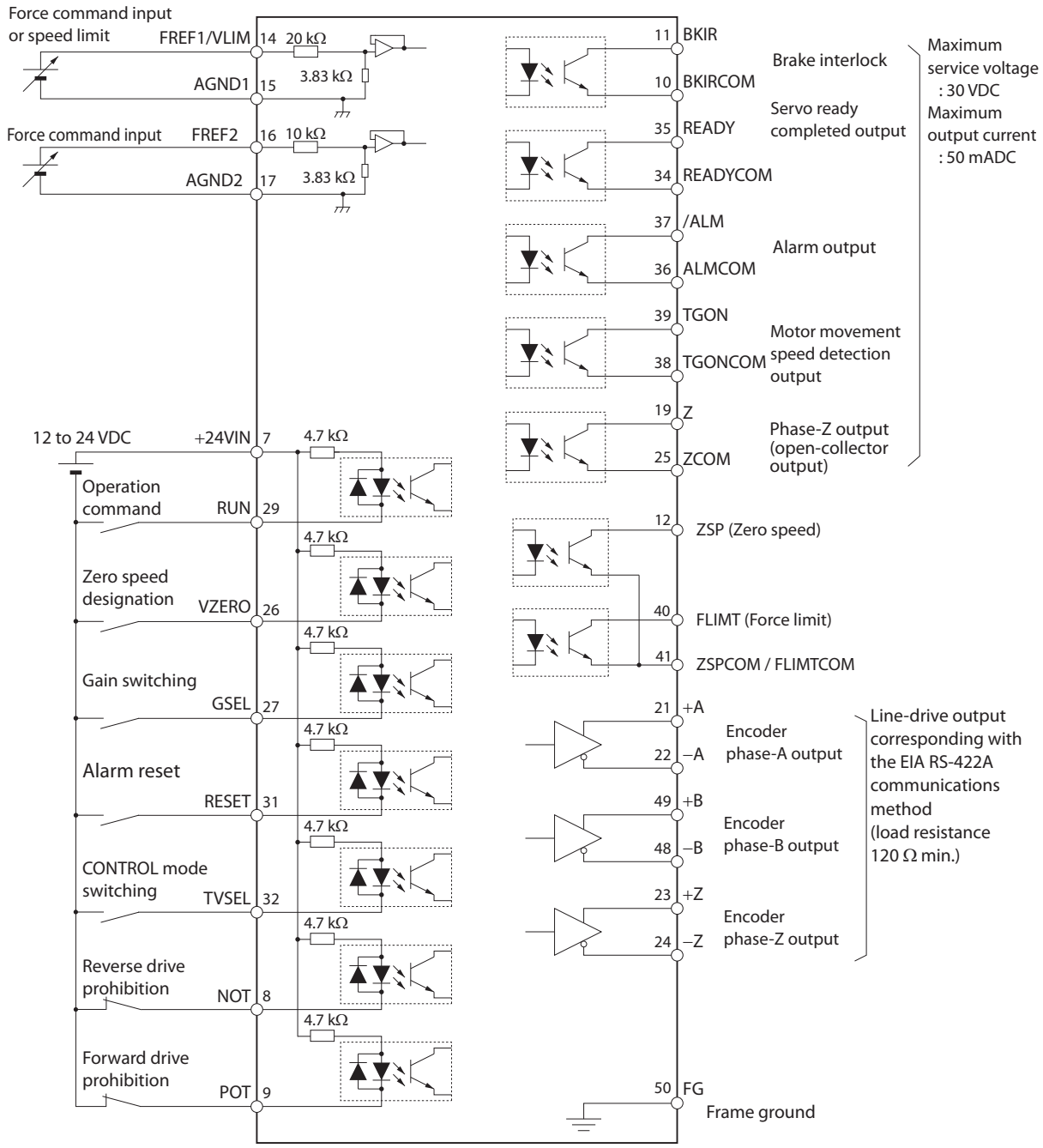

Note 1. The inputs of pins 8, 9 and 26 to 33, and outputs of pins 10, 11, 12, 34, 35, 38, 39 and 40, can be changed via parameter settings.

Specifications

Control I/O Signal List

CN1 Control Inputs

Pin number	Symbol	Name	Function and interface	CONTROL mode		
				Position	Speed	Force
Pulse command input						
1	+24VCW	24-V open-collector input for command pulse	Input terminals for position command pulses for both line drive and open collector. Changes to enable (set value: 0<default setting>) according to the setting of Command Pulse Input Selection (Pn005).	√		
3	+CW/+puls/+FA	Reverse pulse, feed pulse, or 90° phase difference signal (phase A)				
4	-CW/-puls/-FA					
2	+24VCW	24-V open-collector input for command pulse				
5	+CW/+puls/+FA	Forward pulse, direction signal, or 90° phase difference signal (phase B)				
6	-CW/-puls/-FA					
44	+CWLD	Reverse pulse (input for line drive only)	Input terminals for position command pulses dedicated to the line-drive output. Changes to enable (set value: 1) according to the setting of Command Pulse Input Selection (Pn005).	√		
45	-CWLD					
46	+CCWLD	Forward pulse (input for line drive only)				
47	-CCWLD					
14	REF	Speed command input	This is an analog input terminal for speed command. Use the Speed Command Scale (Pn302) to change the force scale for the command input.	√		
	FREF1	Force command input 1	Provides a force command input (set value: 0 or 2) according to the setting of Force Command/Speed Limit Selection (Pn317). Use the Force Command Scale (Pn319) to change the force scale for the command input.			
Analogue command input						
14	VLIM	Speed limit input	Provides a speed limit input (set value: 1) according to the setting of Force Command/Speed Limit Selection (Pn317). Use the Speed Command Scale (Pn302) to change the limit speed scale for the analog input.			√
15	AGND1	Analog ground 1	This is an analog signal ground.			
16	PCL	Forward force limit input	Provides a forward force limit input (set value: 0 or 4) or forward/reverse force limit input (set value: 5) according to the setting of Force Limit Selection (Pn521).	√	√	
	FREF2	Force command input 2	Provides a force command input (set value: 1) according to the setting of Force Command/Speed Limit Selection (Pn317). Use the Force Command Scale (Pn319) to change the movement speed scale for the command input.			√

Pin number	Symbol	Name	Function and interface	CONTROL mode		
				Position	Speed	Force
17	AGND1	Analog ground 1	This is an analog signal ground.			
18	NCL	Reverse force limit input	Provides a reverse force limit input (set value: 0 or 4) according to the setting of Force Limit Selection (Pn521).	√	√	
7	+24VIN	12 to 24-VDC power supply input	This is the positive input terminal of the external DC power supply for sequence input (12 to 24 V).	√	√	√

Digital inputs

8, 9, 26 to 33	NOT [8]	Reverse drive prohibition input	This performs the drive prohibition input in the reverse direction. Changes to enable (set value: 0 or 2) according to the setting of Drive Prohibition Input Selection (Pn504).	√	√	√
	POT [9]	Forward drive prohibition input	This performs the drive prohibition input in the forward direction. Changes to enable (set value: 0 or 2) according to the setting of Drive Prohibition Input Selection (Pn504).	√	√	√
	DFSEL1 [26]	Vibration filter switching 1	Changes to enable (set value: 1 or 2) according to the setting of Vibration Filter Selection (Pn213). If the set value of Vibration Filter Selection (Pn213) is 2, switching between 4 settings is possible by combining this with the vibration filter switching input 2 (DFSEL2).	√		

3-1 Drive Specifications

Pin number	Symbol	Name	Function and interface	CONTROL mode		
				Position	Speed	Force
8, 9, 26 to 33	GSEL [27]	Gain switching	This changes to enable (set value: 2) according to the setting of GAIN SWITCHING mode (Pn115 for position control, Pn120 for speed control, or Pn124 for force control). When the signal is OFF and ON, gain 1 and gain 2 change to enable, respectively.	√	√	√
	GESEL1 [28]	Electronic gear switching 1	Switches the numerator for electronic ratio. You can switch maximum 4 electronic ratio numerators by combining with electronic gear switching input 2 (GESEL2).	√		
	RUN [29]	Operation command input	This turns ON the Linear Servo (motor power supply starts).	√	√	√
	ECRST [30]	Error counter reset input	Resets the position error counter. An edge (set value: 0) or level (set value: 1) can be selected according to the setting of Error Counter Reset Condition Selection (Pn517).	√		
	RESET [31]	Alarm reset input	Release the alarm status. The error counter is reset when the alarm is reset. Some alarms cannot be reset with this input.	√	√	√
	TVSEL [32]	CONTROL mode switching input	This signal switches the CONTROL mode for Linear Servo Drive. Changes to enable (set value: 3 to 5) according to the setting of CONTROL mode Selection (Pn001).	√	√	√
	IPG [33]	Pulse prohibition input	Prohibits the position command pulse. Changes to enable (set value: 0) according to the setting of Command Pulse Prohibition Input Setting (Pn518).	√		
	VSEL1 [33]	Internally set speed selection 1	Use this input to select a desired Speed Setting (Pn304 to 311) during the internally set speed operation.			
	VSEL2 [30]	Internally set speed selection 2			√	
	VSEL3 [28]	Internally set speed selection 3				
	FLSEL	Force limit switching	Switches the force limit value via ON/OFF. Changes to enable (set value: 3 or 6) according to the setting of Force Limit Selection (Pn521). The force limit value and operating direction vary according to the set value.	√	√	
	DFSEL2	Vibration filter switching 2	Changes to enable (set value: 2) according to the setting of Vibration Filter Selection (Pn213). Switching between 4 settings is possible by combining this with the vibration filter switching input 1 (DFSEL1).	√		

Pin number	Symbol	Name	Function and interface	CONTROL mode		
				Position	Speed	Force
8, 9, 26 to 33	GESEL2	Electronic gear switching 2	You can switch maximum 4 electronic ratio numerators by combining with electronic gear switching input 1 (GESEL1).	√		
	VZERO	Zero speed designation input	This signal forcibly sets the speed command to 0. Changes to enable (set value: 1 to 3) according to the setting of Zero Speed Designation Selection (Pn315).		√	√
	VSING	Speed command sign input	Designates the motor movement direction for speed commands. Changes to enable (set value: 1) according to the setting of Speed Command Direction Selection (Pn301).		√	
	FSIGN	Force command sign input	This signal designates the motor movement direction for force commands. Changes to enable (set value: 1) according to the setting of Force Command Direction Selection (Pn318).			√
	EMG-STOP	Emergency stop input	This is an emergency stop input. When input, this becomes an emergency stop input error and thereby stop the motor.	√	√	√
	MSEL	Mass ratio switching input	This signal switches between mass ratio 1 and mass ratio 2.	√	√	√

- ♦ Be cautious that allocatable pin numbers are fixed for the following functions.
 Error counter reset input (ECRST): Pin 30 only
 Command pulse input prohibition input (IPG): Pin 33 only
- ♦ The number in brackets indicates the pin number (allocation) at default setting. (The allocations vary according to each CONTROL mode.)

CN1 Control Outputs

Pin number	Symbol	Name	Function and interface	CONTROL mode		
				Position	Speed	Force
Encoder signal outputs						
21	+A	Encoder phase A +output	Encoder signals are output according to the setting of Encoder Dividing Numerator (Pn011). This is the line-drive output (equivalent to RS-422). The maximum output frequency is 4 Mpps.	√		
22	-A	Encoder phase A -output				
48	+B	Encoder phase B +output				
49	-B	Encoder phase B -output				
23	+Z	Encoder phase Z +output	Phase Z is output for encoder signals. This is the line-drive output (equivalent to RS-422).			
24	-Z	Encoder phase Z -output				
19	-Z	Encoder phase-Z output	Phase Z is output for encoder signals. Open-collector output	√		
25	ZCOM	Encoder phase-Z output common				

Digital outputs

3-1 Drive Specifications

Pin number	Symbol	Name	Function and interface	CONTROL mode		
				Position	Speed	Force
10, 11, 12, 34 to 40	BKIR [11]	Brake interlock output	Outputs the timing signal for operating the electromagnetic brake on a motor.	√	√	√
	BKIRCOM [10]					
	READY [35]	Servo ready completed	This output signal indicates that the drive is turned ON and ready to start operation. It is turned ON when the control and main power supply is established and not in alarm status.	√	√	√
	READYCOM [34]					
	/ALM [37]	Servo alarm	The output is OFF when an alarm is generated for the Linear Servo Drive.	√	√	√
	ALMCOM [36]					
	INP1 [39]	Positioning completion output 1	If the position error is equal to Positioning Completion Range 1 (Pn431) or less, this output turns ON according to the setting condition of Positioning Completion Condition Selection (Pn432).	√		
	INP1COM [38]					
	TGON [39]	Motor movement speed detection output	This output turns ON when the motor movement speed reaches the speed set in Movement Speed for Motor Movement Detection (Pn436).		√	√
	TGONCOM [38]					
	FLIMT [40]	Force limiting output	This output turns ON while the force is limited.	√	√	
	FLIMTCOM [41]					
	ZSP [12]	Zero speed detection signal	This output turns ON when the motor movement speed is equal to Zero Speed Detection (Pn434) or less.	√	√	√
	ZSPCOM [41]					
	VCMP	Speed conformity output	This output turns ON when the command speed corresponds to the motor movement speed. This output turns ON when the difference between the command speed and motor movement speed is inside the setting range of Speed Conformity Detection Width (Pn435).		√	√
	VCMPCOM					
	INP2	Positioning completion output 2	If the position error is equal to Positioning Completion Range 2 (Pn442) or less, this output turns ON according to the setting condition of Positioning Completion Condition Selection (Pn432).	√		
	INP2COM					
	WARN1	Warning output 1	This output turns ON according to the setting condition of Warning Output Selection 1 (Pn440).	√	√	√
	WARN1COM					

Pin number	Symbol	Name	Function and interface	CONTROL mode		
				Position	Speed	Force
10, 11, 12, 34 to 40	WARN2	Warning output 2	This output turns ON according to the setting condition of Warning Output Selection 1 (Pn440).	√	√	√
	WARN2COM					
	P-CMD	Position command status output	This output turns ON when a positioning command is input.	√		
	P-CMDCOM					
	V-LIMIT	Speed limiting output	This turns ON during force control or speed limit status.			√
	V-LIMITCOM					
	ALM-ATB	Alarm clear attribute output	This output turns ON when an alarm occurs or the alarm can be cleared.	√	√	√
	ALM-ATBCOM					
	V-CMD	Speed command status output	This output turns ON during speed control or when a speed command is input.		√	
	V-CMDCOM					

- ◆ You cannot change the allocation for servo alarm output (/ALM). (The allocation is fixed.)
- ◆ The number in brackets indicates the pin number (allocation) at default setting. (The allocations vary according to each CONTROL mode.)
- ◆ Outputs in pins 12 and 40 share the same common pin (41) opposite to the other outputs that have their own common point.

3-1 Drive Specifications

CN1 Pin Arrangement

2	+24VCCW	Open collector supply	1	+24VCW	Open collector supply	27	SI4	General purpose Digital In 4	26	SI3	General purpose Digital In 3
4	CW-	Open collector pulse input	3	CW+	Open collector pulse input	29	SI6	General purpose Digital In 6	28	SI5	General purpose Digital In 5
6	CCW-	Open collector pulse input	5	CCW+	Open collector pulse input	31	SI8	General purpose Digital In 8	30	SI7	General purpose Digital In 7
8	SI1	General purpose Digital In 1	7	COM+	Common for digital input	33	SI10	General purpose Digital In 10	32	SI9	General purpose Digital In 9
10	SO1-	DO1 common	9	SI2	General purpose Digital In 2	35	SO2+	Digital output 2	34	SO2-	DO2 common
12	SO5+	Digital output 5	11	SO1+	Digital output 1	37	ALM+	Alarm output common	36	ALM-	ALARM output
14	AI1	Analogue input 1	13	GND	Ground general purpose	39	SO4+	Digital output 4	38	SO4-	DO4 common
16	AI2	Analogue input 2	15	GND	Ground general purpose	41	SO5- & SO6-	Common for SO5 & SO6	40	SO6+	Digital output 6
18	AI3	Analogue input 3	17	GND	Ground general purpose	43	-	Not used	42	-	Not used
20	-	Not used	19	CZ	Channel Z out Open collector	45	CWLD-	Line-drive pulse inputs	44	CWLD+	Line-drive pulse inputs
22	OA-	Channel A out	21	OA+	Channel A out	47	CCWLD-	Line-drive pulse inputs	46	CCWLD+	Line-drive pulse inputs
24	OZ-	Channel Z out	23	OZ+	Channel Z out	49	OB+	Channel B out	48	OB-	Channel B out
			25	GND	Ground general purpose				50	FG	FG

Note. Do not wire anything to unused pins (*).

For general-purpose inputs 1 to 10 (SI1 to SI10) and general-purpose outputs (SO1, SO2 and SO4), use user parameters Pn400 to Pn409 (Input Signal Selections 1 to 10) and Pn410 to Pn415 (Output Signal Selections 1 to 6) to set the function allocations.

The alarm output (/ALM) is fixed to general-purpose output 3.

Connectors for CN1 (Pin 50)

Name	Model	Manufacturer
Drive connector	52986-3679	Molex Japan
Cable plug	10150-3000PE	Sumitomo 3M
Cable case (shell kit)	10350-52A0-008	

Control Input Circuits

Speed Command Input, Force Command Input and Speed Limit Input

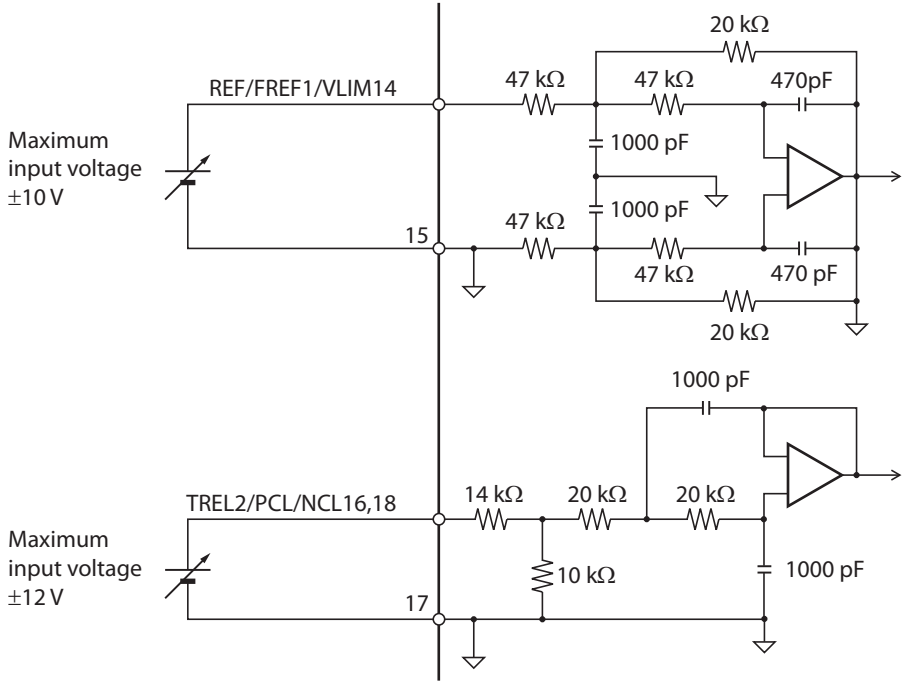

- The maximum allowable input voltage is ± 10 V for each input. The VR must be 2 k Ω with B characteristics and 1/2 W minimum. R must be 200 Ω and 1/2 W minimum.

Position Command Pulse (Line Receiver Input)

When connecting with a line drive and a line receiver, up to 4 Mpps will be available. (+CWLD: 44, -CWLD: 45, +CCWLD: 46, -CCWLD: 47)

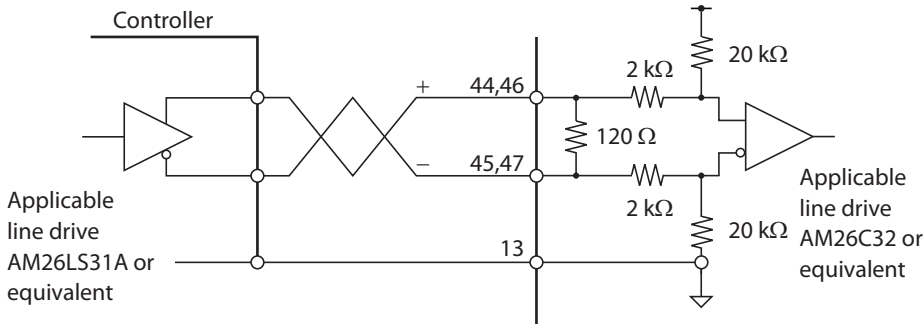

- The shielded twisted-pair cable should not exceed 20 m in length.

Specifications

Position Command Pulse (Photocoupler Input)

Line Drive Input (500 kpps Maximum)

(+CW: 3, -CW: 4, +CCW: 5, -CCW: 6)

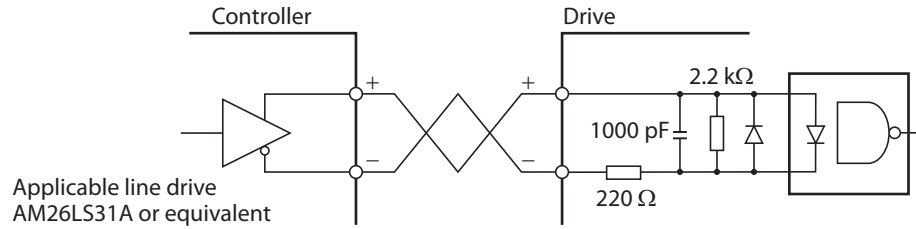

Precautions for Correct Use

- ♦ The twisted-pair cable should not exceed 10 m in length.

Open Collector Input

- External 24-V power supply without a Current Limit Resistor (200 kpps maximum) (+24 VCW: 1, -CW: 4, +24 VCCW: 2, -CCW: 6)

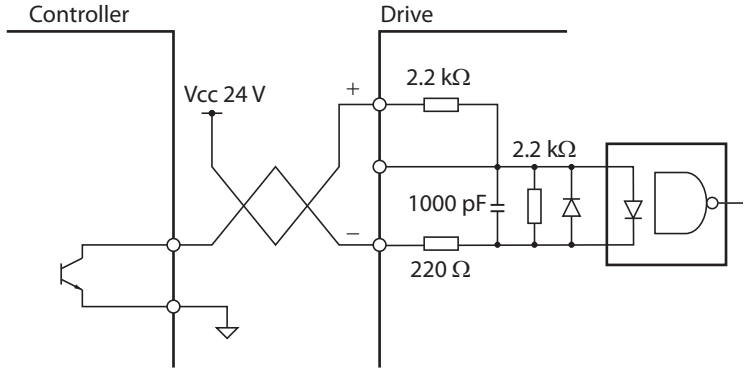

- External control power supply (200 kpps maximum) (+CW: 3, -CW: 4, +CCW: 5, -CCW: 6)

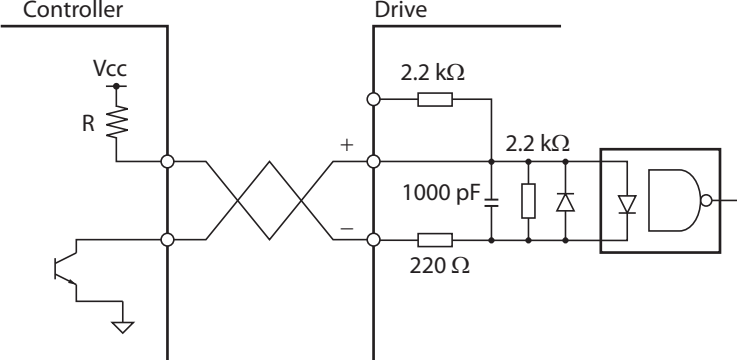

Select a Current Limit Resistor (R) appropriate for Vcc.32

$$\frac{V_{cc} - 1.5}{R + 220} \approx 10\text{mA} \quad (7 \text{ to } 15 \text{ mA})$$

VCC	R
24 V	2 kΩ (1/2 W)
12 V	1 kΩ (1/2 W)
5 V	0 Ω (short)

Precautions for Correct Use

- The open collector wiring should not exceed 2 m in length.

Specifications

General-purpose Input

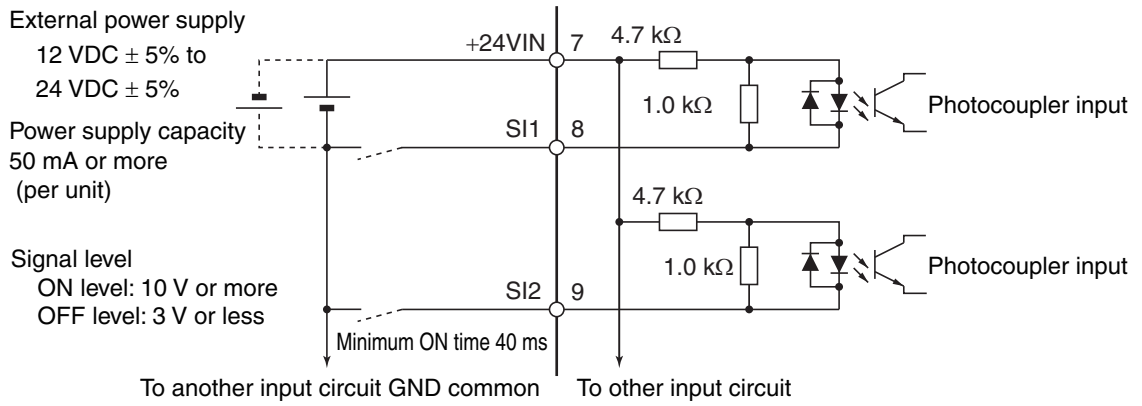

Control Input Details

Details on the input pins for the CN1 connector are described here.

High-speed Photocoupler Input

- Pin 3: +Reverse pulse (+CW), +feed pulse (+PULS), or +phase A (+FA)
- Pin 4: -Reverse pulse (-CW), -feed pulse (-PULS), or -phase A (-FA)
- Pin 5: +Forward pulse (+CCW), +direction signal (+SIGN), or +phase B (+FB)
- Pin 6: -Forward pulse (-CCW), -direction signal (-SIGN), or -phase B (-FB)

Function

- ♦ The functions of these signals depend on the settings of the Command Pulse Movement Direction Switching Selection (Pn006) and the COMMAND PULSE mode Selection (Pn007).

Pn005 Set value	Pn006 Set value	Pn007 Set value	COMMAND PULSE mode	Input pins	Motor forward command	Motor reverse command
0	0	0/2	90° phase difference signals (quadruple multiplier)	3: +FA 4: -FA 5: +FB 6: -FB		
		1	Reverse pulse/forward pulse	3: +CW 4: -CW 5: +CCW 6: -CCW		
		3	Feed pulse/direction signal	3: +PULS 4: -PULS 5: +SIGN 6: -SIGN		

Note 1. If the Command Pulse Movement Direction Switching Selection (Pn006) is set to 1, the movement will be reversed.

Note 2. If the photocoupler LED is turned ON, each signal will go high as shown above.

3-1 Drive Specifications

Command Pulse Timing for Photocoupler Inputs

Note: The Maximum input frequency corresponds to the frequency AFTER interpolation (x2 in forward-reverse and in frequency-direction and x4 in 90° phase difference).

COMMAND PULSE mode	Timing												
<p>Feed pulse/direction signal</p> <p>Maximum input frequency Line drive: 500 kpps Open collector: 200 kpps</p>	<table border="1" style="margin-left: auto; margin-right: auto;"> <thead> <tr> <th>At 200 kpps</th> <th>At 500 kpps</th> </tr> </thead> <tbody> <tr> <td>$t1 \leq 0.5 \mu\text{s}$</td> <td>$t1 \leq 0.1 \mu\text{s}$</td> </tr> <tr> <td>$t2 > 2.5 \mu\text{s}$</td> <td>$t2 > 1.0 \mu\text{s}$</td> </tr> <tr> <td>$\tau \geq 2.5 \mu\text{s}$</td> <td>$\tau \geq 1.0 \mu\text{s}$</td> </tr> <tr> <td>$T \geq 5.0 \mu\text{s}$</td> <td>$T \geq 2.0 \mu\text{s}$</td> </tr> <tr> <td>$(\tau/T) \times 100 \leq 50 (\%)$</td> <td>$(\tau/T) \times 100 \leq 50 (\%)$</td> </tr> </tbody> </table>	At 200 kpps	At 500 kpps	$t1 \leq 0.5 \mu\text{s}$	$t1 \leq 0.1 \mu\text{s}$	$t2 > 2.5 \mu\text{s}$	$t2 > 1.0 \mu\text{s}$	$\tau \geq 2.5 \mu\text{s}$	$\tau \geq 1.0 \mu\text{s}$	$T \geq 5.0 \mu\text{s}$	$T \geq 2.0 \mu\text{s}$	$(\tau/T) \times 100 \leq 50 (\%)$	$(\tau/T) \times 100 \leq 50 (\%)$
At 200 kpps	At 500 kpps												
$t1 \leq 0.5 \mu\text{s}$	$t1 \leq 0.1 \mu\text{s}$												
$t2 > 2.5 \mu\text{s}$	$t2 > 1.0 \mu\text{s}$												
$\tau \geq 2.5 \mu\text{s}$	$\tau \geq 1.0 \mu\text{s}$												
$T \geq 5.0 \mu\text{s}$	$T \geq 2.0 \mu\text{s}$												
$(\tau/T) \times 100 \leq 50 (\%)$	$(\tau/T) \times 100 \leq 50 (\%)$												
<p>Reverse pulse/forward pulse</p> <p>Maximum input frequency Line drive: 500 kpps Open collector: 200 kpps</p>	<table border="1" style="margin-left: auto; margin-right: auto;"> <thead> <tr> <th>At 200 kpps</th> <th>At 500 kpps</th> </tr> </thead> <tbody> <tr> <td>$t1 \leq 0.5 \mu\text{s}$</td> <td>$t1 \leq 0.1 \mu\text{s}$</td> </tr> <tr> <td>$t2 > 2.5 \mu\text{s}$</td> <td>$t2 > 1.0 \mu\text{s}$</td> </tr> <tr> <td>$\tau \geq 2.5 \mu\text{s}$</td> <td>$\tau \geq 1.0 \mu\text{s}$</td> </tr> <tr> <td>$T \geq 5.0 \mu\text{s}$</td> <td>$T \geq 2.0 \mu\text{s}$</td> </tr> <tr> <td>$(\tau/T) \times 100 \leq 50 (\%)$</td> <td>$(\tau/T) \times 100 \leq 50 (\%)$</td> </tr> </tbody> </table>	At 200 kpps	At 500 kpps	$t1 \leq 0.5 \mu\text{s}$	$t1 \leq 0.1 \mu\text{s}$	$t2 > 2.5 \mu\text{s}$	$t2 > 1.0 \mu\text{s}$	$\tau \geq 2.5 \mu\text{s}$	$\tau \geq 1.0 \mu\text{s}$	$T \geq 5.0 \mu\text{s}$	$T \geq 2.0 \mu\text{s}$	$(\tau/T) \times 100 \leq 50 (\%)$	$(\tau/T) \times 100 \leq 50 (\%)$
At 200 kpps	At 500 kpps												
$t1 \leq 0.5 \mu\text{s}$	$t1 \leq 0.1 \mu\text{s}$												
$t2 > 2.5 \mu\text{s}$	$t2 > 1.0 \mu\text{s}$												
$\tau \geq 2.5 \mu\text{s}$	$\tau \geq 1.0 \mu\text{s}$												
$T \geq 5.0 \mu\text{s}$	$T \geq 2.0 \mu\text{s}$												
$(\tau/T) \times 100 \leq 50 (\%)$	$(\tau/T) \times 100 \leq 50 (\%)$												
<p>90° phase difference signals</p> <p>Maximum input frequency Line drive: 500 kpps Open collector: 200 kpps</p>	<table border="1" style="margin-left: auto; margin-right: auto;"> <thead> <tr> <th>At 200 kpps</th> <th>At 500 kpps</th> </tr> </thead> <tbody> <tr> <td>$t1 \leq 0.5 \mu\text{s}$</td> <td>$t1 \leq 0.1 \mu\text{s}$</td> </tr> <tr> <td>$\tau \geq 10 \mu\text{s}$</td> <td>$\tau \geq 4.0 \mu\text{s}$</td> </tr> <tr> <td>$T \geq 20 \mu\text{s}$</td> <td>$T \geq 8.0 \mu\text{s}$</td> </tr> <tr> <td>$(\tau/T) \times 100 \leq 50 (\%)$</td> <td>$(\tau/T) \times 100 \leq 50 (\%)$</td> </tr> </tbody> </table>	At 200 kpps	At 500 kpps	$t1 \leq 0.5 \mu\text{s}$	$t1 \leq 0.1 \mu\text{s}$	$\tau \geq 10 \mu\text{s}$	$\tau \geq 4.0 \mu\text{s}$	$T \geq 20 \mu\text{s}$	$T \geq 8.0 \mu\text{s}$	$(\tau/T) \times 100 \leq 50 (\%)$	$(\tau/T) \times 100 \leq 50 (\%)$		
At 200 kpps	At 500 kpps												
$t1 \leq 0.5 \mu\text{s}$	$t1 \leq 0.1 \mu\text{s}$												
$\tau \geq 10 \mu\text{s}$	$\tau \geq 4.0 \mu\text{s}$												
$T \geq 20 \mu\text{s}$	$T \geq 8.0 \mu\text{s}$												
$(\tau/T) \times 100 \leq 50 (\%)$	$(\tau/T) \times 100 \leq 50 (\%)$												

Line Receiver Input

- Pin 44: +Reverse pulse (+CW), +feed pulse (+PULS), or +phase A (+FA)
- Pin 45: -Reverse pulse (-CW), -feed pulse (-PULS), or -phase A (-FA)
- Pin 46: +Forward pulse (+CCW), +direction signal (+SIGN), or +phase B (+FB)
- Pin 47: -Forward pulse (-CCW), -direction signal (-SIGN), or -phase B (-FB)

Function

- ♦ The functions of these signals depend on the settings of the Command Pulse Movement Direction Switching Selection (Pn006) and the COMMAND PULSE mode Selection (Pn007).

Pn005 Set value	Pn006 Set value	Pn007 Set value	COMMAND PULSE mode	Input pins	Motor forward command	Motor reverse command
1	0	0/2	90° phase difference signals (quadruple multiplier)	44: +FA 45: -FA 46: +FB 47: -FB		
		1	Reverse pulse/forward pulse	44: +CW 45: -CW 46: +CCW 47: -CCW		
		3	Feed pulse/direction signal	44: +PULS 45: -PULS 46: +SIGN 47: -SIGN		

Note 1. If the Command Pulse Movement Direction Switching Selection (Pn006) is set to 1, the movement direction will be reversed.

Command Pulse Timing for Line Receiver Inputs

Note: The Maximum input frequency corresponds to the frequency AFTER interpolation (x2 in forward-reverse and in frequency-direction and x4 in 90° phase difference).

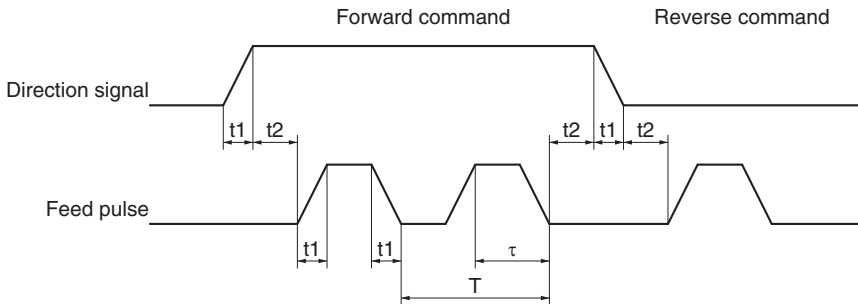
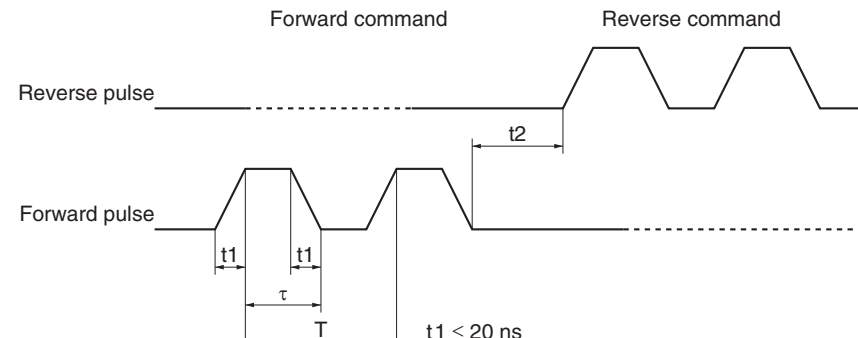
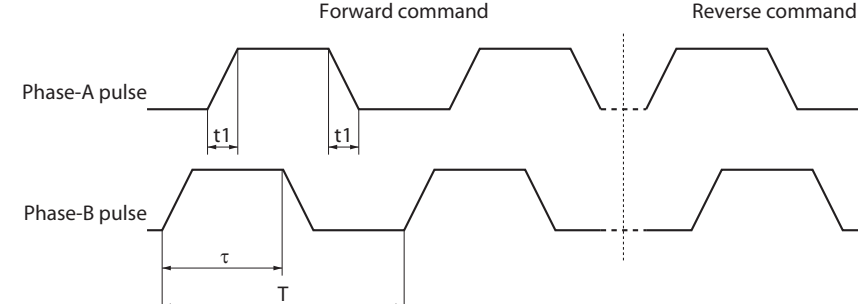
COMMAND PULSE mode	Timing
<p>Feed pulse/direction signal</p> <p>Maximum input frequency Line drive: 4 Mpps</p>	 <p> $t1 \leq 20 \text{ ns}$ $t2 > 500 \text{ ns}$ $\tau \geq 250 \text{ ns}$ $T \geq 500 \text{ ns}$ $(\tau/T) \times 100 \leq 50 (\%)$ </p>
<p>Reverse pulse/forward pulse</p> <p>Maximum input frequency Line drive: 4 Mpps</p>	 <p> $t1 \leq 20 \text{ ns}$ $t2 > 500 \text{ ns}$ $\tau \geq 250 \text{ ns}$ $T \geq 500 \text{ ns}$ $(\tau/T) \times 100 \leq 50 (\%)$ </p>
<p>90° phase difference signals</p> <p>Maximum input frequency Line drive: 4 Mpps</p>	 <p> $t1 \leq 20 \text{ ns}$ $\tau \geq 0.5 \mu\text{s}$ $T \geq 1 \mu\text{s}$ $(\tau/T) \times 100 \leq 50 (\%)$ </p>

Speed Command Input (REF), Force Command Input (FREF1) and Speed Limit Input (VLIM)

Pin 14: Speed command input (REF), force command Input (FREF1) and speed limit input (VLIM)

Pin 15: Analog input ground (AGND1)

Function

- ♦ During speed control
Speed command is input. Use the Speed Command Scale (Pn302) to change the movement speed scale for the command input.
- ♦ During force control
This signal provides either a force command input (set value: 0 or 2) or speed limit input (set value: 1) according to the setting of Force Command/Speed Limit Selection (Pn317).
In the case of force command input 1 (FREF1), you can use Force Command Scale (Pn319) to change the movement speed scale relative to the command input.
In the case of speed limit input (VLIM), you can use the Speed Command Scale (Pn302) to change the limit speed scale relative to the analog input.

Force Command Input 2 (FREF2) and Forward Force Limit Input (PCL)

Pin 16: Force command input 2 (FREF2) and forward force limit input (PCL)

Pin 17: Analog input ground 2 (AGND2)

Function

- ♦ During position control or speed control
This signal provides a forward force limit input (set value: 0 or 4) or forward/reverse force limit input (set value: 5) according to the setting of Force Limit Selection (Pn521).
You can use Analog Force Limit Scale (Pn527) to change the force limit scale relative to the analog input.
- ♦ During force control
This signal provides a force command input (set value: 1) according to the setting of Force Command/Speed Limit Selection (Pn317).
In the case of force command input 2 (FREF2), you can use Force Command Scale (Pn319) to change the movement speed scale relative to the command input.

Reverse Force Limit Input (NCL)

Pin 18: Reverse force limit input (NCL)

Pin 17: Analog input ground 2 (AGND2)

Function

- ♦ During position control or speed control
This signal provides a reverse force limit input (set value: 0 or 4) according to the setting of Force Limit Selection (Pn521).
You can use Analog Force Limit Scale (Pn527) to change the force limit scale relative to the analog input.

Operation command (RUN)

Pin 29: Operation command (RUN)

This is the allocation at default setting. You can change the logics and allocations for input terminals (CN1 to 8, 9 and 26 to 33) according to the settings of Input Signal Selection 1 to 10 (Pn400 to 409).

You must always allocate the Operation command (RUN). If not, the servo does not turn ON.

Function

This input turns ON the power drive circuit for the main circuit of the Linear Servo Drive. If this signal is not input (servo OFF), the motor cannot drive.

Forward Drive Prohibition Input (POT) and Reverse Drive Prohibition Input (NOT)

Pin 9: Forward drive prohibition input (POT)

Pin 8: Reverse drive prohibition input (NOT)

This is the allocation at default setting. Note, however, that both signals are set to disable (drive prohibition is disabled). You can use Drive Prohibition Input Setting (Pn504) to change these settings. Also, you can change the logics and allocations for input terminals (CN1 to 8, 9 and 26 to 33) according to the settings of Input Signal Selection 1 to 10 (Pn400 to 409).

Function

These 2 signals are drive prohibition (overtravel) inputs in forward and reverse directions.

If Drive Prohibition Input Setting (Pn504) is 1, you can use the setting of Stop Selection (Pn505) to select the operation to be taken upon input of each prohibit signal.

If Drive Prohibition Input Setting (Pn504) is 2, drive prohibition input protection (E380) actuates upon input of a drive prohibition.

Alarm Reset Input (RESET)

Pin 31: Alarm reset input (RESET)

This is the allocation at default setting. You can change the logics and allocations for input terminals (CN1 to 8, 9 and 26 to 33) according to the settings of Input Signal Selection 1 to 10 (Pn400 to 409).

The input logic for the alarm reset input (RESET) is always contact a. (You cannot set contact b.)

Function

It is the external reset input for servo alarm. (A reset occurs at the rising edge of this input.)

Inputting for 120 ms or more releases an alarm condition.

An alarm reset also resets the content of the error counter, upon which the position loop becomes no longer effective.

Eliminate the cause of the alarm before resuming operation. To prevent danger, turn OFF the Operation command (RUN) first, then input the alarm reset signal.

Some alarms cannot be reset with this input.

Error Counter Reset Input (ECRST)

Pin 30: Error counter reset input (ECRST)

This is the allocation at default setting. You can change the functions for input terminals (CN1 to 8, 9 and 26 to 33) according to the settings of Input Signal Selection 1 to 10 (Pn400 to 409). You can only allocate the error counter reset input (ECRST) to pin 30 (SI7). Allocating to any other terminal generates an error counter reset signal allocation error (A332).

The input logic for the error counter reset input (ECRST) is always contact a. (You cannot set contact b.)

Function

Inputting the error counter reset resets the content of the error counter, upon which the position loop becomes no longer effective.

You can use Error Counter Reset Condition Selection (Pn517) to set the status (level) signal (ON) or differential (rising edge) signal (from OFF to ON).

Input the differential signal for at least 100 μ s, or status signal for at least 1 ms. A reset may not occur if the time is shorter.

CONTROL mode Switching (TVSEL)

Pin 32: CONTROL mode switching (TVSEL)

This is the allocation at default setting. You can change the logics and allocations for input terminals (CN1 to 8, 9 and 26 to 33) according to the settings of Input Signal Selection 1 to 10 (Pn400 to 409).

Function

If the CONTROL mode Selection (Pn001) is set to 3 to 5, the CONTROL mode can be switched as given in the following table.

Pn001 set value	OFF (FIRST CONTROL mode)	ON (SECOND CONTROL mode)
3	Position control	Speed control
4	Position control	Force control
5	Speed control	Force control

Gain Switching (GSEL)

Pin 27: Gain switching (GSEL)

This is the allocation at default setting. You can change the logics and allocations for input terminals (CN1 to 8, 9 and 26 to 33) according to the settings of Input Signal Selection 1 to 10 (Pn400 to 409).

Function

This signal changes to enable (set value: 2) according to the setting of GAIN SWITCHING mode (Pn115 for position control, Pn120 for speed control, or Pn124 for force control).

When the signal is OFF and ON, gain 1 and gain 2 change to enable, respectively.

Vibration Filter Switching 1 (DFSEL1) and Vibration Filter Switching 2 (DFSEL2)

Pin 26: Vibration filter switching 1 (DFSEL1)

No allocation: Vibration filter switching 2 (DFSEL2)

This is the allocation at default setting. You can change the logics and allocations for input terminals (CN1 to 8, 9 and 26 to 33) according to the settings of Input Signal Selection 1 to 10 (Pn400 to 409).

Function

Use the sequence signal to switch among the 4 filters for use in damping control when the setting of Vibration Filter Selection (Pn213) is enable (set value: 1 or 2).

Pn213 set value	DFSEL1	DFSEL2	Vibration filter 1	Vibration filter 2	Vibration filter 3	Vibration filter 4
1	OFF	–	Enabled		Enabled	
	ON	–		Enabled		Enabled
2	OFF	OFF	Enabled			
	ON	OFF		Enabled		
	OFF	ON			Enabled	
	ON	ON				Enabled

Electronic Gear Switching 1 (GESEL1) and Electronic Gear Switching 2 (GESEL2)

Pin 28: Electronic gear switching 1 (GESEL1)

No allocation: Electronic gear switching 2 (GESEL2)

This is the allocation at default setting. You can change the logics and allocations for input terminals (CN1 to 8, 9 and 26 to 33) according to the settings of Input Signal Selection 1 to 10 (Pn400 to 409).

Function

Use these 2 signals to switch among up to 4 electronic ratio numerators.

GESEL1	GESEL2	Electronic Gear 1	Electronic Gear 2	Electronic Gear 3	Electronic Gear 4
OFF	OFF	Pn009 valid			
ON	OFF		Pn500 valid		
OFF	ON			Pn501 valid	
ON	ON				Pn502 valid

♦ Electronic Ratio Denominator (Pn010) is a common setting.

Specifications

Pulse Prohibition Input (IPG)

Pin 33: Pulse prohibition input (IPG)

This is the allocation at default setting. However, Command Pulse Prohibition Input (Pn518) is set to disable (set value: 1). To use this, change Pn518 to enable (set value: 0). You can change the functions for input terminals (CN1 to 8, 9 and 26 to 33) according to the settings of Input Signal Selection 1 to 10 (Pn400 to 409).

You can only allocate the pulse prohibition input (ECRST) to pin 33 (SI10). Allocating this input to any other terminal generates a pulse prohibition input allocation error (A337).

Function

You can use this input to forcibly stop the command pulse input.

When this input is ON, the drive ignores the command pulse input and does not count pulses.

Internally Set Speed Selection 1, 2 and 3 (VSEL1, 2 and 3)

Pin 33: Internally set speed selection 1 (VSEL1) Pin 30: Internally set speed selection 2 (VSEL2)

Pin 28: Internally set speed selection 3 (VSEL3)

This is the allocation at default setting. However, Command Speed Selection (Pn300) is set to disable (set value: 0). To use this, change Command Speed Selection (Pn300) to enable (set value: 1 to 3). You can change the logics and allocations for input terminals (CN1 to 8, 9 and 26 to 33) according to the settings of Input Signal Selection 1 to 10 (Pn400 to 409).

Function

Perform speed control according to the internal speed set value in the parameter.

You can select from up to 8 internal speed set values.

Pn300 set value	VSEL1	VSEL2	VSEL3	Speed command selection
1	OFF	OFF	–	No. 1 Internally Set Speed (Pn304)
	ON	OFF	–	No. 2 Internally Set Speed (Pn305)
	OFF	ON	–	No. 3 Internally Set Speed (Pn306)
	ON	ON	–	No. 4 Internally Set Speed (Pn307)
2	OFF	OFF	–	No. 1 Internally Set Speed (Pn304)
	ON	OFF	–	No. 2 Internally Set Speed (Pn305)
	OFF	ON	–	No. 3 Internally Set Speed (Pn306)
	ON	ON	–	Analog speed command input (REF)
3	OFF	OFF	OFF	No. 1 Internally Set Speed (Pn304)
	ON	OFF	OFF	No. 2 Internally Set Speed (Pn305)
	OFF	ON	OFF	No. 3 Internally Set Speed (Pn306)
	ON	OFF	OFF	No. 4 Internally Set Speed (Pn307)
	OFF	OFF	ON	No. 5 Internally Set Speed (Pn308)
	ON	OFF	ON	No. 6 Internally Set Speed (Pn309)
	OFF	ON	ON	No. 7 Internally Set Speed (Pn310)
	ON	ON	ON	No. 8 Internally Set Speed (Pn311)

To use the internally set speed, use the zero speed designation input (VZERO) as contact b. (If this is OFF, the speed command becomes 0.) The zero speed designation input (VZERO) is set to disable (set value: 0) by default. To use this, change Zero Speed Designation Selection (Pn315) to enable (set value: 1 to 2).

(If the zero speed designation input is not used, the motor turns at No. 1 Internally Set Speed (Pn304) when the servo turns ON.)

Zero Speed Designation (VZERO)

No allocation: Zero speed designation (VZERO)

There is no allocation at default setting. Also, Zero Speed Designation Selection (Pn315) is set to disable (set value: 1). You can change the logics and allocations for input terminals (CN1 to 8, 9 and 26 to 33) according to the settings of Input Signal Selection 1 to 10 (Pn400 to 409).

Function

You can use this input to forcibly change the speed command to 0.

This signal changes to enable (set value: 1 to 3) according to the setting of Zero Speed Designation Selection (Pn315).

Pn300 set value	Operation when ON
0	Zero speed designation is disabled.
1	The speed command becomes 0.
2	The speed command becomes 0, and a position lock occurs at a motor movement speed equal to Position Lock Level Setting (Pn316) or less.
3	A position lock occurs at a command speed equal to Position Lock Level Setting (Pn316) or less.

Speed Command Sign Input (VSIGN)

No allocation: Speed command sign designation (VSIGN)

There is no allocation at default setting. Also, Speed Command Direction Selection (Pn301) is set to disable (set value: 0). You can change the logics and allocations for input terminals (CN1 to 8, 9 and 26 to 33) according to the settings of Input Signal Selection 1 to 10 (Pn400 to 409).

Function

You can use this input to designate the movement direction relative to the speed command.

If Speed Command Direction Selection (Pn301) is enable (set value: 1), the polarity of analog command input and movement direction at internal command speed become disabled.

Pn301 set value	Pn303 set value	VSIGN	Analog speed command input (REF)	Motor movement direction
0	0	Operation Disabled	+Voltage (0 to +10 V)	Forward operation
			-Voltage (-10 to 0 V)	Reverse operation
	1		+Voltage (0 to +10 V)	Reverse operation
			-Voltage (-10 to 0 V)	Forward operation
1	Setting Disabled	OFF	+Voltage (0 to +10 V)	Forward operation
			-Voltage (-10 to 0 V)	
		ON	+Voltage (0 to +10 V)	Reverse operation
			-Voltage (-10 to 0 V)	

Pn301 set value	VSIGN	Internal command speed	Motor movement direction
0	OFF	+ (Forward command: 0 to +max speed mm/s)	Forward operation
		- (Reverse command: -max speed to 0 mm/s)	Reverse operation
	ON	+ (Forward command: 0 to +max speed mm/s)	Forward operation
		- (Reverse command: -max speed to 0 mm/s)	Reverse operation
1	OFF	+ (Forward command: 0 to +max speed mm/s)	Forward operation
		- (Reverse command: -max speed to 0 mm/s)	
	ON	+ (Forward command: 0 to +max speed mm/s)	Reverse operation
		- (Reverse command: -max speed to 0 mm/s)	

Force Limit Switching (FLSEL)

No allocation: Force Limit Switching (FLSEL)

There is no allocation at default setting. You can change the logics and allocations for input terminals (CN1 to 8, 9 and 26 to 33) according to the settings of Input Signal Selection 1 to 10 (Pn400 to 409).

Function

This input is used for switching the force limit value.

This signal changes to enable (set value: 3 or 6) according to the setting of Force Limit Selection (Pn521).

Pn521 set value	FLSEL	Forward	Reverse
3	OFF	Pn013 (No. 1 Force Limit)	Pn013 (No. 1 Force Limit)
	ON	Pn522 (No. 2 Force Limit)	Pn522 (No. 2 Force Limit)
6	OFF	Pn013 (No. 1 Force Limit)	Pn522 (No. 2 Force Limit)
	ON	Pn525 (Forward External Force Limit)	Pn526 (Reverse External Force Limit)

Force Command Sign Input (FSIGN)

No allocation: Force command sign input (FSIGN)

There is no allocation at default setting. Also, Force Command Direction Selection (Pn318) is set to disable (set value: 0). You can change the logics and allocations for input terminals (CN1 to 8, 9 and 26 to 33) according to the settings of Input Signal Selection 1 to 10 (Pn400 to 409).

Function

You can use this input to designate the movement direction relative to the force command.

If Force Command Direction Selection (Pn301) is enable (set value: 1), the polarity of force command input is disabled.

Pn318 Set value	Pn320 Set value	FSIGN	Force command input (FREF)	Motor movement direction
0	0	Operation Disabled	+Voltage (0 to +10 V)	Forward operation
			-Voltage (-10 to 0 V)	Reverse operation
	1		+Voltage (0 to +10 V)	Reverse operation
			-Voltage (-10 to 0 V)	Forward operation
1	Setting Disabled	OFF	+Voltage (0 to +10 V)	Forward operation
			-Voltage (-10 to 0 V)	
		ON	+Voltage (0 to +10 V)	Reverse operation
			-Voltage (-10 to 0 V)	

Emergency Stop Input (EMG-STP)

No allocation: Emergency stop input (EMG-STP)

There is no allocation at default setting. You can change the logics and allocations for input terminals (CN1 to 8, 9 and 26 to 33) according to the settings of Input Signal Selection 1 to 10 (Pn400 to 409).

Function

This is an external alarm stop input.

Upon input of an emergency stop, the system stops according to the set value of Stop Selection for Alarm Generation (Pn510).

Mass Ratio Switching Input (MSEL)

No allocation: Mass ratio switching input (MSEL)

This is the allocation at default setting. You can change the logics and allocations for input terminals (CN1 to 8, 9 and 26 to 33) according to the settings of Input Signal Selection 1 to 10 (Pn400 to 409).

Function

You can switch the mass ratio between Mass Ratio 1 (Pn004) and Mass Ratio 2 (Pn613). When this signal is OFF, Mass Ratio 1 (Pn004) becomes valid. If ON, Mass Ratio 2 (Pn613) becomes valid.

Control Output Circuits

Position Feedback Output

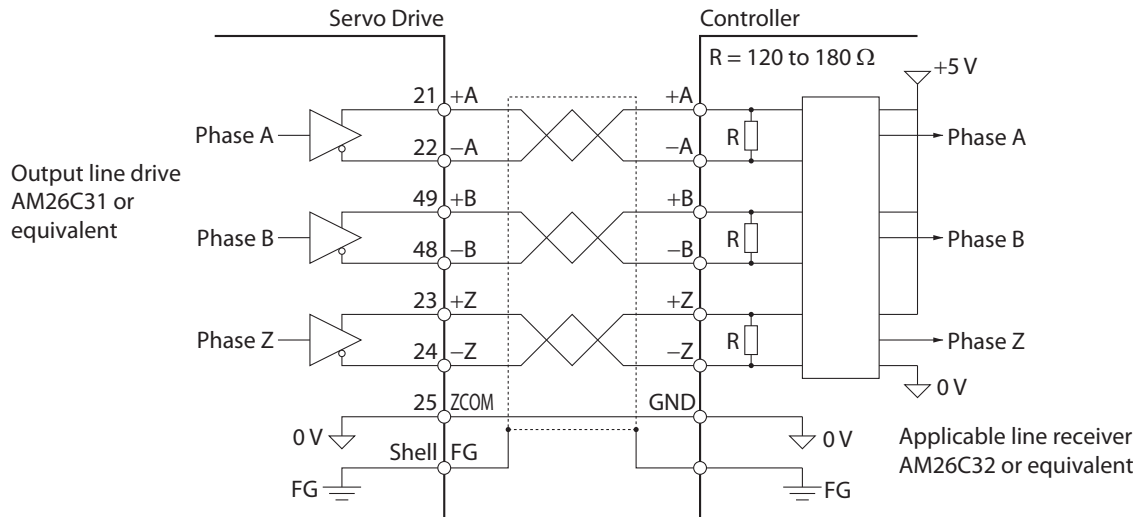

Phase-Z Output (Open Collector Output)

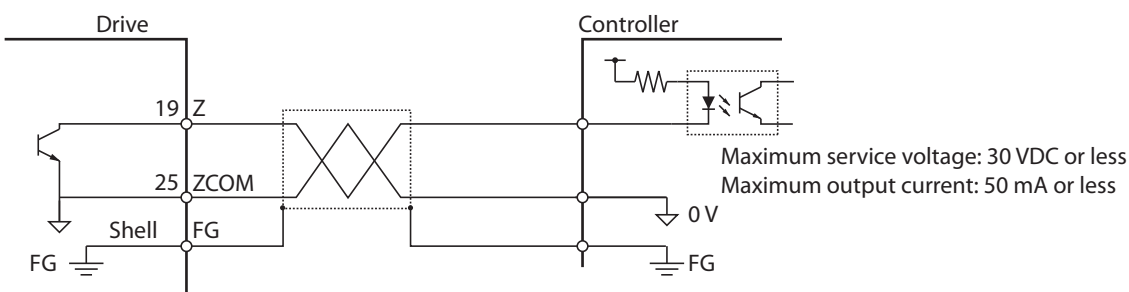

Sequence Output

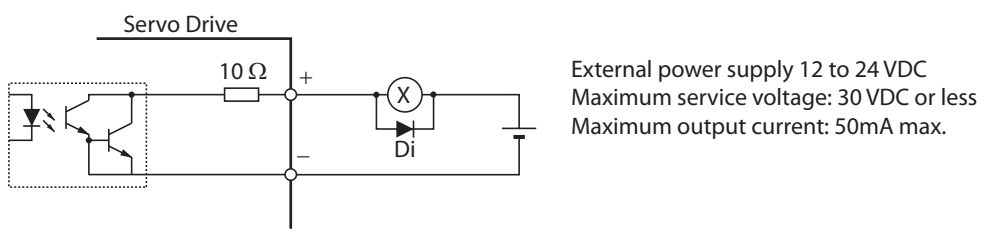

Di: Surge voltage prevention diode
(Use a high-speed diode.)

S05 (Pin 12) and S06 (Pin 40) share the same common pin (Pin 41).

Specifications

Control Output Details

Control Output Sequence

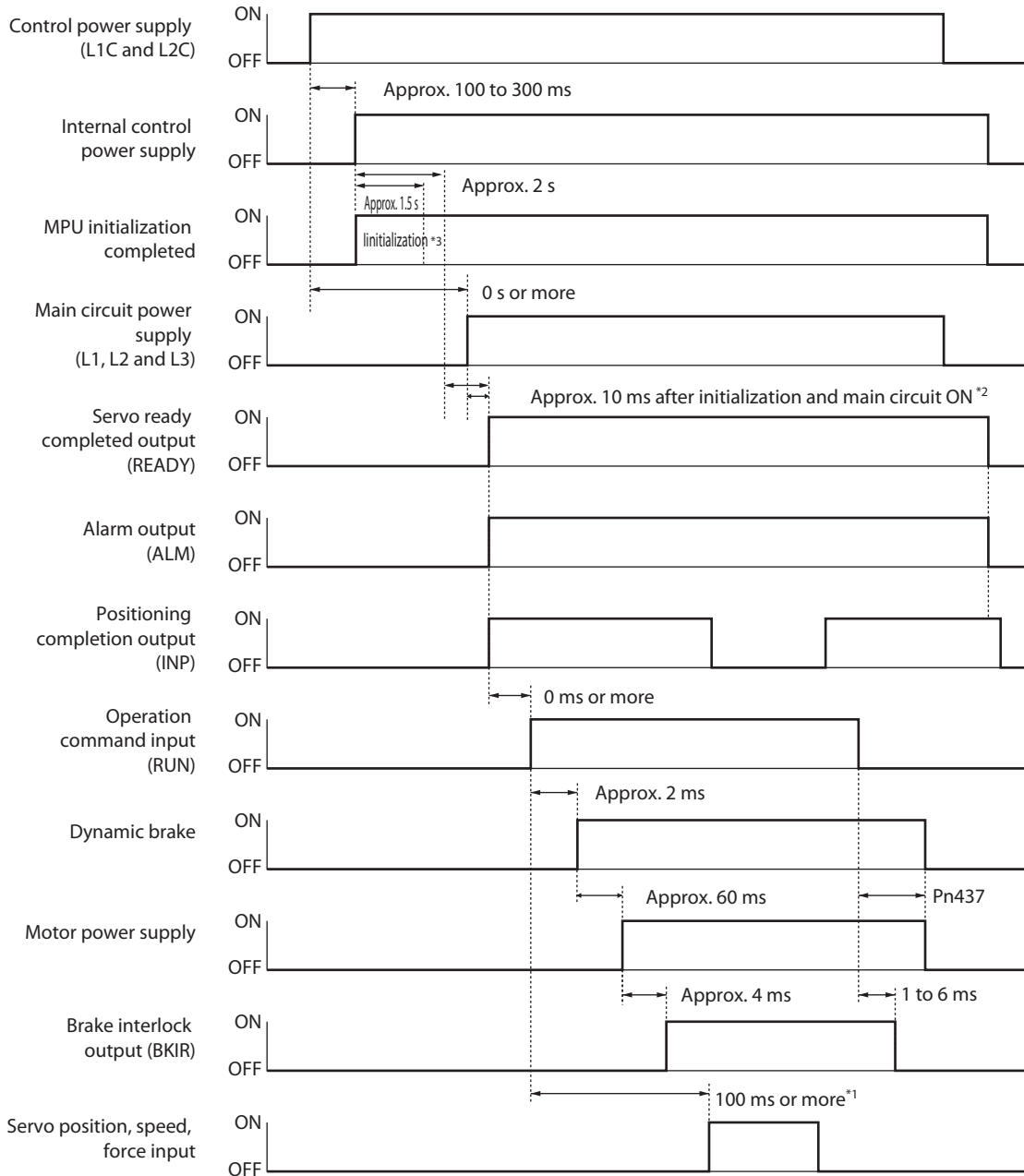

- *1. In this section, the hardware inputs the servo ON signal, but the signal is not accepted.
- *2. The servo ready completed output turns ON the moment the conditions of MPU initialization completed and main circuit power supply establishment are both satisfied.
- *3. Operation of the protective function starts approx. 1.5 seconds after the start of MPU initialization following an establishment of internal control power supply. Make sure all I/O signals which connect to the amplifier (especially forward/reverse direction and drive prohibition input) are established before operation of the protective function starts. Also, you can increase this time with Pn618 "Power Supply ON Initialization Time."

Specifications

Encoder Outputs (Phases A, B and Z)

Pin 21: +A, 22: -A, 48: -B, 49: +B, 23: +Z, 24: -Z

Function

- ♦ It outputs the phase A, phase B, and phase Z encoder signals for the Linear Servomotor.
- ♦ The encoder outputs conform to the RS-422 communication method.
- ♦ You can use Encoder Feedback Pulse Dividing Numerator Setting (Pn011) and Encoder Feedback Pulse Dividing Denominator Setting (Pn503) to set the dividing ratio.
- ♦ The logical relation of phase B to the phase A pulse and the output source are set in the Encoder Output Selection Switching (Pn012).
- ♦ The ground for the output circuit line drive is connected to the signal ground (SENGND). It is not isolated.
- ♦ The maximum output frequency is 4 Mpps (after quadruple multiplier).
- ♦ The output frequency = $(Pn011 / Pn503) \times (10^6 / \text{encoder resolution } (\mu\text{m/pulse})) \times \text{motor speed (m/s)}$.
- ♦ The output phases are as shown below.

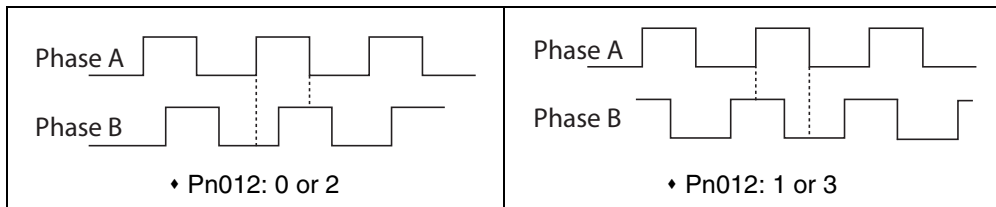

- ♦ In A/B pulse or SinCos Encoder, the Z pulse is repeated from the Feedback Encoder, independently of the output pulse phase.
- ♦ In Serial Absolute Feedback Scale, phase Z is output at intervals set in Pn621 after the motor crosses the 0 point.

Brake Interlock Output (BKIR)

Pin 11: Brake interlock output (BKIR)

Pin 10: Brake interlock output common (BKIRCOM)

This is the allocation at default setting. You can change the allocations of output terminals (CN1 to 10, 11, 12, 34, 35, 38, 39, 40 and 41) according to the settings of Output Signal Selections 1 to 6 (Pn410 to 415).

Function

This outputs an external brake timing signal according to the settings of the Brake Timing when Stopped (Pn437) and Brake Timing during Operation (Pn438).

Note: In linear motors, the brake is an external element that, if needed, must be installed separately by the user.

Servo Ready Completed Output (READY)

Pin 35: Servo ready completed output (READY)

Pin 34: Servo ready completed output common (READYCOM)

This is the allocation at default setting. You can change the allocations of output terminals (CN1 to 10, 11, 12, 34, 35, 38, 39, 40 and 41) according to the settings of Output Signal Selections 1 to 6 (Pn410 to 415).

Function

This output signal indicates that the drive is turned ON and ready to start operation. It is turned ON when the control and main power supply is established and not in alarm status.

Alarm Output (/ALM)

Pin 37: Alarm Output (/ALM)

Pin 36: Alarm output common (ALMCOM)

The alarm output terminal is fixed to pin 36 or 37.

Function

The output is turned OFF when the drive detects an error.

This output is OFF at power supply ON, but turns ON when the drive's initial processing has been completed.

Positioning Completion Output 1 (INP1) and Positioning Completion Output 2 (INP2)

Pin 39: Positioning completion output 1 (INP1)

Pin 38: Positioning completion output common (INP1COM)

No allocation: Positioning completion output 2 (INP2)

No allocation: Positioning completion output 2 (INP2COM)

This is the allocation at default setting. You can change the allocations of output terminals (CN1 to 10, 11, 12, 34, 35, 38, 39, 40 and 41) according to the settings of Output Signal Selections 1 to 6 (Pn410 to 415).

Function

The INP1 turns ON when the error counter accumulated pulse is less than or equal to the Positioning Completion Range 1 (Pn431) set value.

The INP2 turns ON when the error counter accumulated pulse is less than or equal to the Positioning Completion Range 2 (Pn442) set value.

The output turns ON according to Positioning Completion Condition Selection (Pn432).

Speed Conformity Output (TGON)

Pin 39: Speed conformity output (TGON)

Pin 39: Speed conformity output common (TGONCOM)

This is the allocation at default setting. You can change the allocations of output terminals (CN1 to 10, 11, 12, 34, 35, 38, 39, 40 and 41) according to the settings of Output Signal Selections 1 to 6 (Pn410 to 415).

Function

It turns ON when the speed of the Linear Servomotor exceeds the set value of the Speed for Motor Movement Detection (Pn436).

Force Limiting Signal (FLIMT)

Pin 40: Force limiting signal (FLIMT)

Pin 41: Force limiting signal common (FLIMCOM)

This is the allocation at default setting. You can change the allocations of output terminals (CN1 to 10, 11, 12, 34, 35, 38, 39, 40 and 41) according to the settings of Output Signal Selections 1 to 6 (Pn410 to 415).

Function

This output turns ON while the force is limited.

Zero Speed Detection Signal (ZSP)

Pin 12: Zero speed detection signal (ZSP)

Pin 41: Zero speed detection signal common (ZSPCOM)

This is the allocation at default setting. You can change the allocations of output terminals (CN1 to 10, 11, 12, 34, 35, 38, 39, 40 and 41) according to the settings of Output Signal Selections 1 to 6 (Pn410 to 415).

Function

This output turns ON when the motor movement speed is equal to Zero Speed Detection (Pn434) or less.

Speed Conformity Output Signal (VCMP)

No allocation: Speed conformity output signal (VCMP)

No allocation: Speed conformity output signal common (VCMPCOM)

This is the allocation at default setting. You can change the allocations of output terminals (CN1 to 10, 11, 12, 34, 35, 38, 39, 40 and 41) according to the settings of Output Signal Selections 1 to 6 (Pn410 to 415).

Function

This output turns ON when the command speed corresponds to the motor movement speed. This output turns ON when the difference between the command speed and motor movement speed is inside the setting range of Speed Conformity Detection Width (Pn435).

Warning Output 1 (WARN1) and Warning Output 2 (WARN2)

No allocation: Warning output 1 (WARN1) and warning output 2 (WARN2)

No allocation: Warning output 1 common (WARN1COM) and warning output 2 common (WARN2COM)

This is the allocation at default setting. You can change the allocations of output terminals (CN1 to 10, 11, 12, 34, 35, 38, 39, 40 and 41) according to the settings of Output Signal Selections 1 to 6 (Pn410 to 415).

Function

The output turns ON according to the setting conditions of Warning Output Selection 1 (Pn440) and Warning Output Selection 2 (Pn441).

Position Command Status Output (P-CMD)

No allocation: Position command status output (P-CMD)

No allocation: Position command status output common (P-CMDCOM)

This is the allocation at default setting. You can change the allocations of output terminals (CN1 to 10, 11, 12, 34, 35, 38, 39, 40 and 41) according to the settings of Output Signal Selections 1 to 6 (Pn410 to 415).

Function

This output turns ON when a positioning command is input.

Speed Limiting Output (V-LIMIT)

No allocation: Speed limiting output (V-LIMIT)

No allocation: Speed limiting output common (V-LIMITCOM)

This is the allocation at default setting. You can change the allocations of output terminals (CN1 to 10, 11, 12, 34, 35, 38, 39, 40 and 41) according to the settings of Output Signal Selections 1 to 4 (Pn410 to 415).

Function

This turns ON during force control or speed limit status.

Alarm Clear Attribute Output (ALM-ATB)

No allocation: Alarm clear attribute output (ALM-ATB)

No allocation: Alarm clear attribute output common (ALM-ATB COM)

This is the allocation at default setting. You can change the allocations of output terminals (CN1 to 10, 11, 12, 34, 35, 38, 39, 40 and 41) according to the settings of Output Signal Selections 1 to 6 (Pn410 to 415).

Function

This output turns ON when an alarm occurs or the alarm can be cleared.

Speed Command Status Output (V-CMD)

No allocation: Speed command status output (V-CMD)

No allocation: Speed command status output common (V-CMDCOM)

This is the allocation at default setting. You can change the allocations of output terminals (CN1 to 10, 11, 12, 34, 35, 38, 39, 40 and 41) according to the settings of Output Signal Selections 1 to 6 (Pn410 to 415).

Function

This output turns ON during speed control or when a speed command is input.

Encoder Connector Specifications (CN4)

Connects to the encoder.

There are three types of encoder that can be connected (parameter selectable):

- A/B line-drive pulse encoder connected directly to pin 5 to 10.

- SinCos encoder via the Serial Converter interface to pin 3 and 4 (optionally it is possible to connect the hall sensor and the temperature sensor to the Serial Converter.

- Encoders with integrated serial protocol (absolute and incremental specification) to pin 3 and 4. See section 3-5 for details).

Pin number	Symbol	Name	Function and interface
1	E5V	Encoder power supply output	Use at 5.2 V \pm 5% and at or below 250 mA.
2	E0V		This is connected to the control circuit ground connected to connector CN1.
3	PS	Encoder signal I/O (Serial signal)	Performs the serial signal input and output when SinCos encoder is used via Serial Converter.
4	/PS		
5	EXA	Encoder signal input (Phase A, B, and Z signals)	Performs the input and output of phase A, B, and Z signals when pulse encoder is used.
6	/EXA		
7	EXB		
8	/EXB		
9	EXZ		
10	/EXZ		
Shell	FG	Frame ground	Frame ground

Connection of Encoder Input Signal and Processing of External Signals

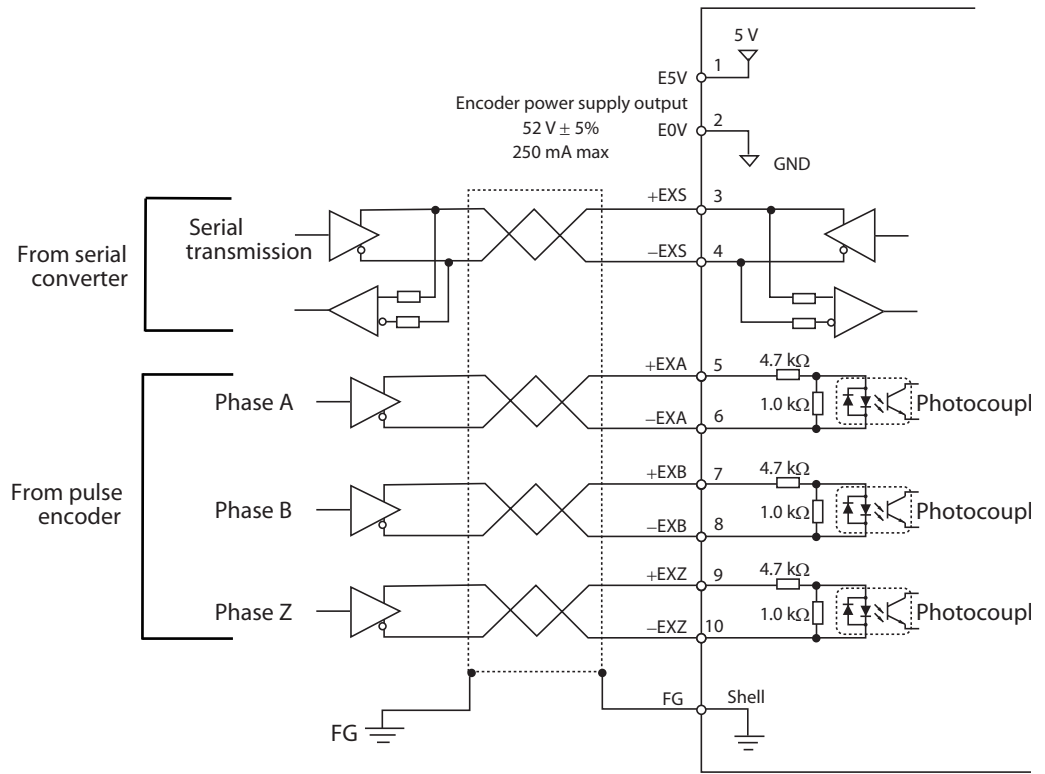

Encoder Input Signals List

Encoder I/O (CN4)

Pin number	Symbol	Name	Function and interface
1	E5V	Encoder power supply output	Encoder power supply 5.2 VDC \pm 5%, 250 mA max. If the above capacity is to be exceeded, provide a separate power supply.
2	E0V		
3	+EXS	Encoder signal Serial interface	This is an Encoder serial bi-directional signal.*(Conforming to EIA485) Maximum response frequency 400 Mpps
4	-EXS		
5	+EXA	Encoder signal 90° phase difference input (Phases A, B and Z)	This is an Encoder 90 phase input signal.* Maximum response frequency 4 Mpps (quadruple multiplier)
6	-EXA		
7	+EXB		
8	-EXB		
9	+EXZ		
10	-EXZ		

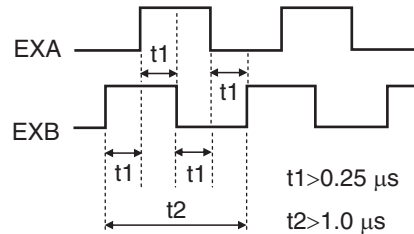

* Connect encoder signals to the serial interface (+EXS/-EXS) or 90° phase difference input according to the encoder type.

Connector for CN4 (Pin 10)

Name	Model	Manufacturer
MUF connector	MUF-PK10K-X	JST Mfg. Co., Ltd.

Example of Connection with Encoder

■ 90 Phase Difference Input Type (Pn323 = 0)

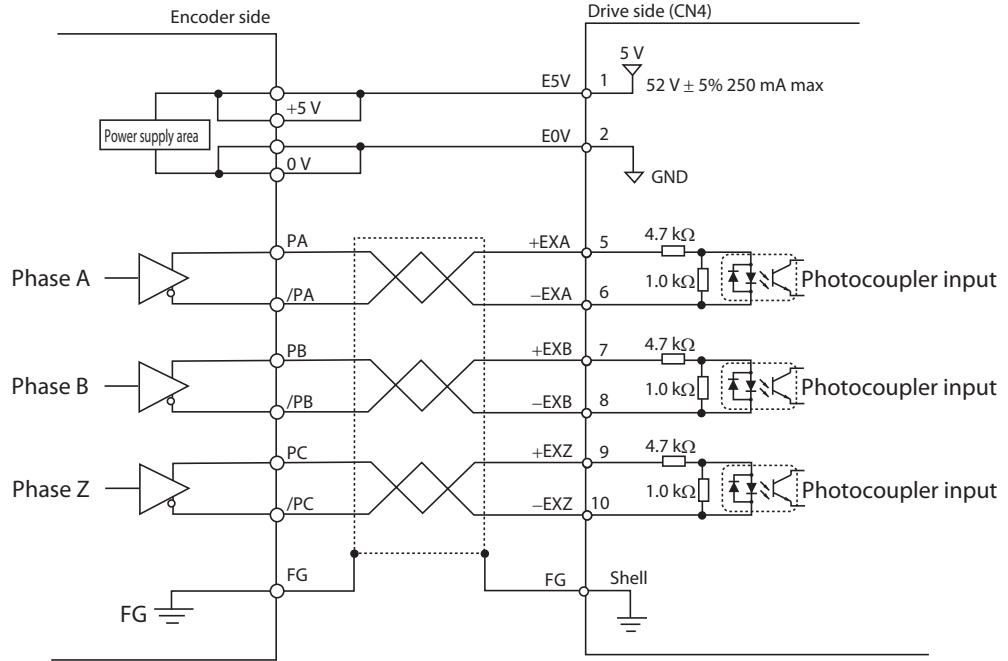

■ SinCos Type through a Serial Converter (Pn323 = 1)

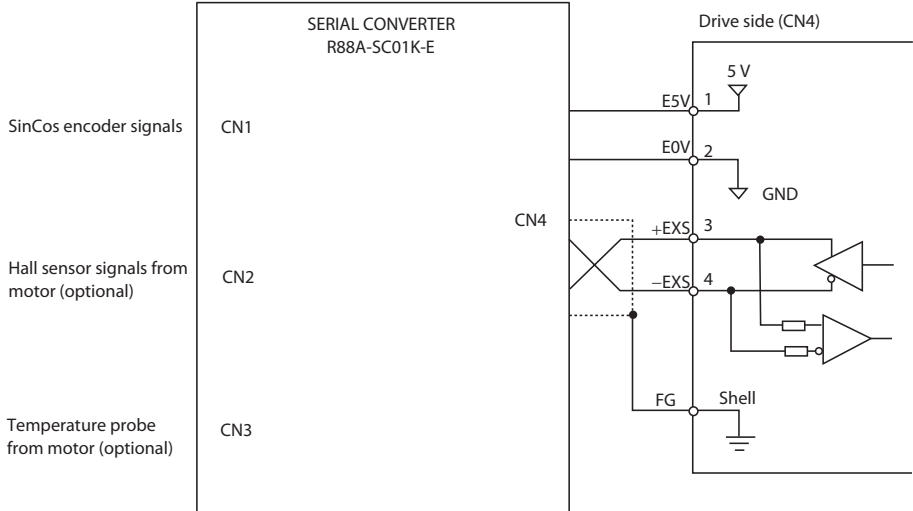

Note: The Serial Converter is an interface that reads the SinCos signals from the encoder, makes a x100 interpolation after quadrature (x400 before quadrature) and, optionally, also combines the hall sensor signals to avoid the phase-finding sequence the first run after power, and the temperature sensors from the motor, then, it sends the information cyclically to the G5-Linear via the encoder serial interface.

■ Serial Communications Type, Incremental Encoder Specifications (Pn323 = 1)

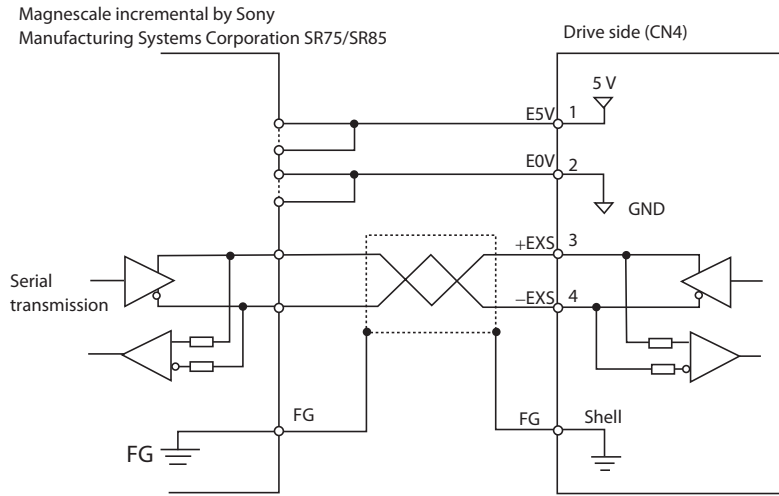

Specifications

3-1 Drive Specifications

■ Serial Communications Type, Absolute Encoder Specifications (Pn323 = 2)

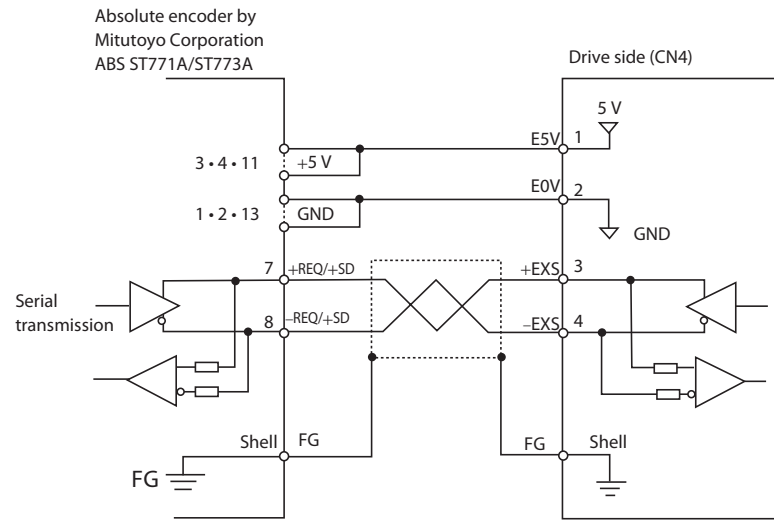

Monitor Connector Specifications (CN5)

Monitor Output Signals List

Monitor output (CN5)

Pin Number	Symbol	Name	Function and interface
1	AM1	Analog monitor output 1	Outputs the analog signal for the monitor. Default setting: Motor speed 1 V/(500 mm/s) You can use Pn416 and Pn417 to change the item and unit. You can use Pn421 to change the output method.
2	AM2	Analog monitor output 2	Outputs the analog signal for the monitor. Default setting: Motor force 1 V/(33% of nominal force) You can use Pn418 and Pn419 to change the item and unit. You can use Pn421 to change the output method.
3	GND	Analog monitor ground	Ground for analog monitors 1, 2
4	–	Not used	Do not connect.
5	–	Not used	Do not connect.
6	–	Not used	Do not connect.

Connectors for CN5 (Pin 6)

Name	Model	Manufacturer
Connector housing	51004-0600	Molex Japan
Connector terminal	50011-8000	Molex Japan

Monitor output circuit

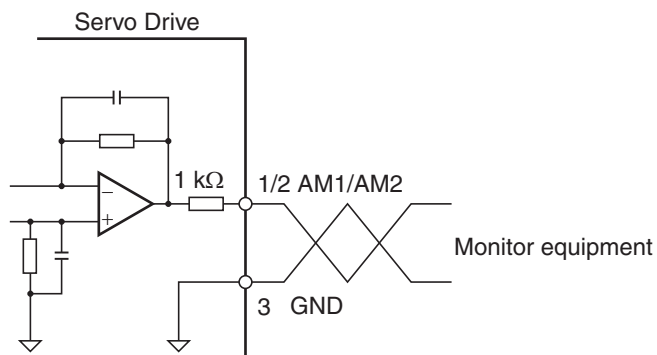

3-1 Drive Specifications

USB Connector Specifications (CN7)

Through the USB connection with computer, operations such as parameter setting and changing, monitoring of control status, checking error status and error history, and parameter saving and loading can be performed.

Pin number	Symbol	Name	Function and interface
1	VBUS	USB signal terminal	Use this function for computer communication.
2	D-		
3	D+		
4	-	Reserved for manufacturer use	Do not connect.
5	SENGND	Signal ground	Signal ground

Safety Connector Specifications (CN8)

Connection of Safety I/O Signals and Processing of External Signals

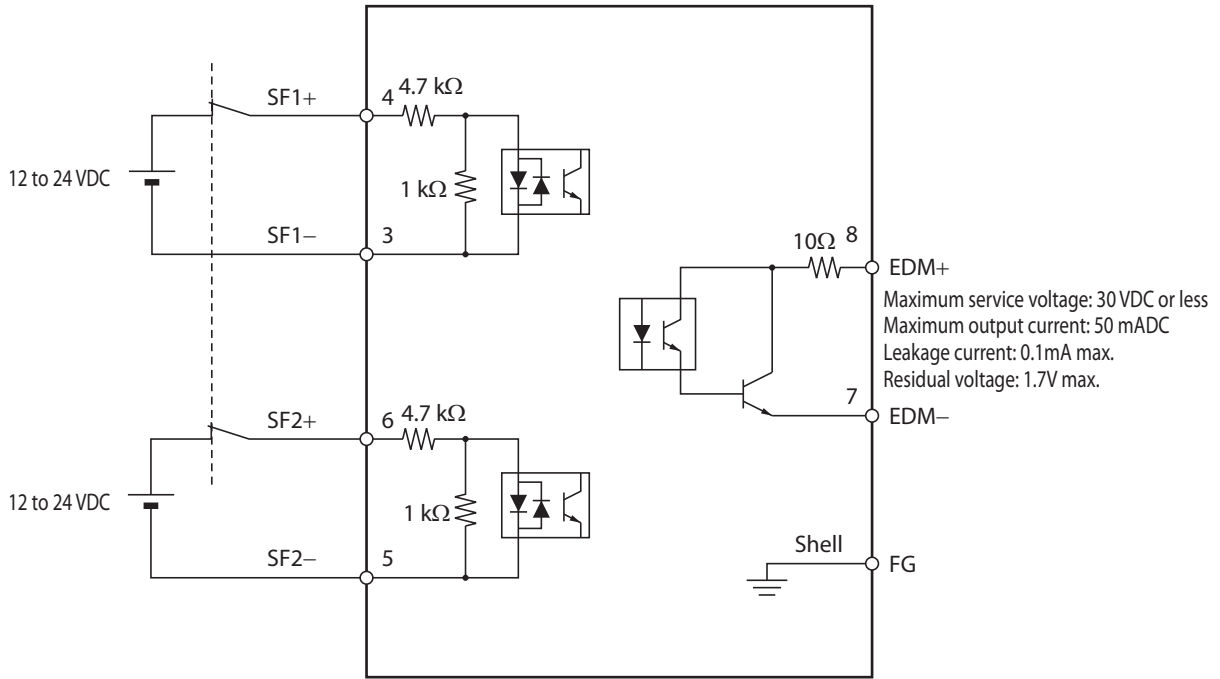

Safety I/O Signals List

Safety I/O (CN8)

Pin Number	Symbol	Name	Function and interface
1	–	Reserved	Do not connect.
2	–		
3	SF1–	Safety input 1	Inputs 1 and 2 for operating the STO function, which are 2 independent circuits. This input turns OFF the power transistor drive signals in the Linear Servo Drive to cut off the current output to the motor.
4	SF1+		
5	SF2–	Safety input 2	
6	SF2+		
7	EDM–	EDM output	A monitor signal is output to detect a safety function failure.
8	EDM+		
Shell	FG	Frame ground	Connected to the ground terminal inside the Linear Servo Drive.

Connector for CN8 (Pin 8)

Name	Model	Manufacturer
Industrial Mini I/O Connector (D-SHAPE1)	2013595-1	Tyco Electronics AMP KK

Safety Input Circuit

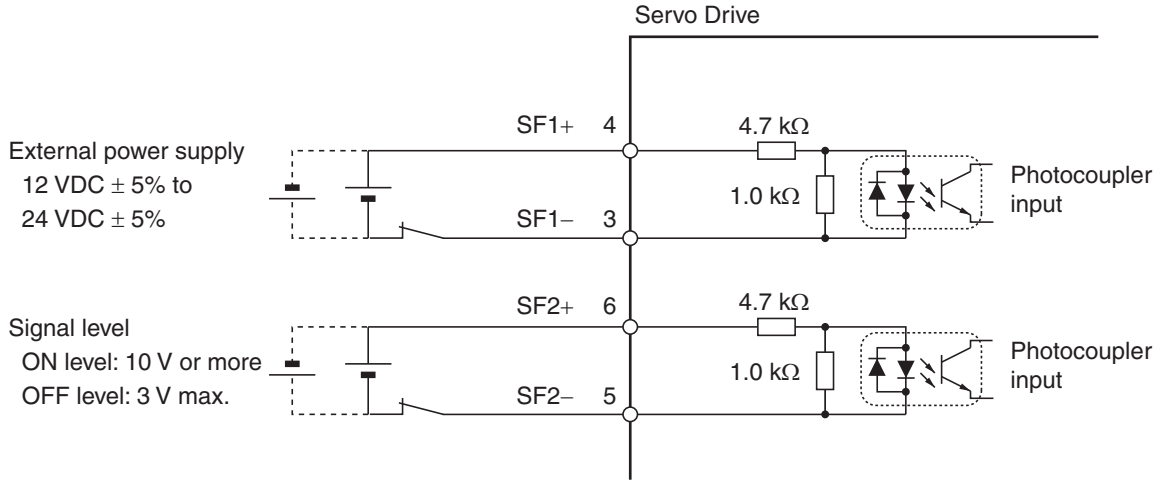

EDM Output Circuit

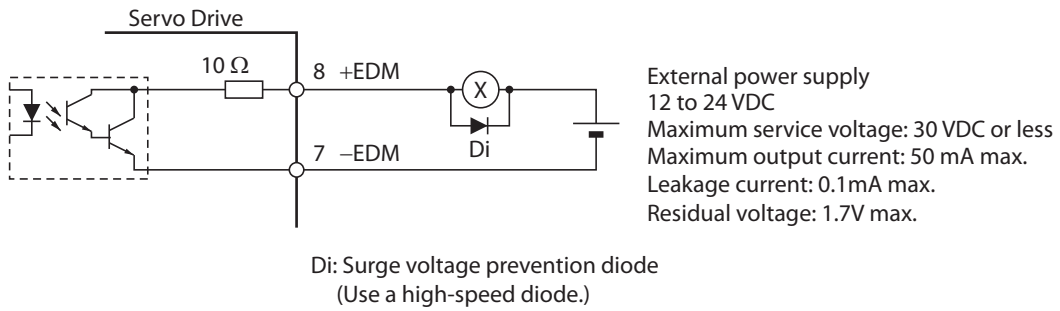

Specifications

3-2 Overload Characteristics (Electronic Thermal Function)

An overload protection function (electronic thermal) is built into the drive to protect the drive and motor from overloading.

If an overload does occur, first eliminate the cause of the error and then wait at least 1 minute for the motor temperature to drop before turning ON the power again.

If the alarm reset is repeated at short intervals, the motor windings may burn out.

Overload Characteristics Graphs

The following graphs show the characteristics of the load ratio and electronic thermal function's operation time.

You can select the suitable overload curve depending on the linear servomotor and the installation and environmental conditions by setting the parameter Pn929.

The linear servomotor can continuously work at 115% of its rated current. The time to give the Overload alarm depends on the overload level and the curve selected.

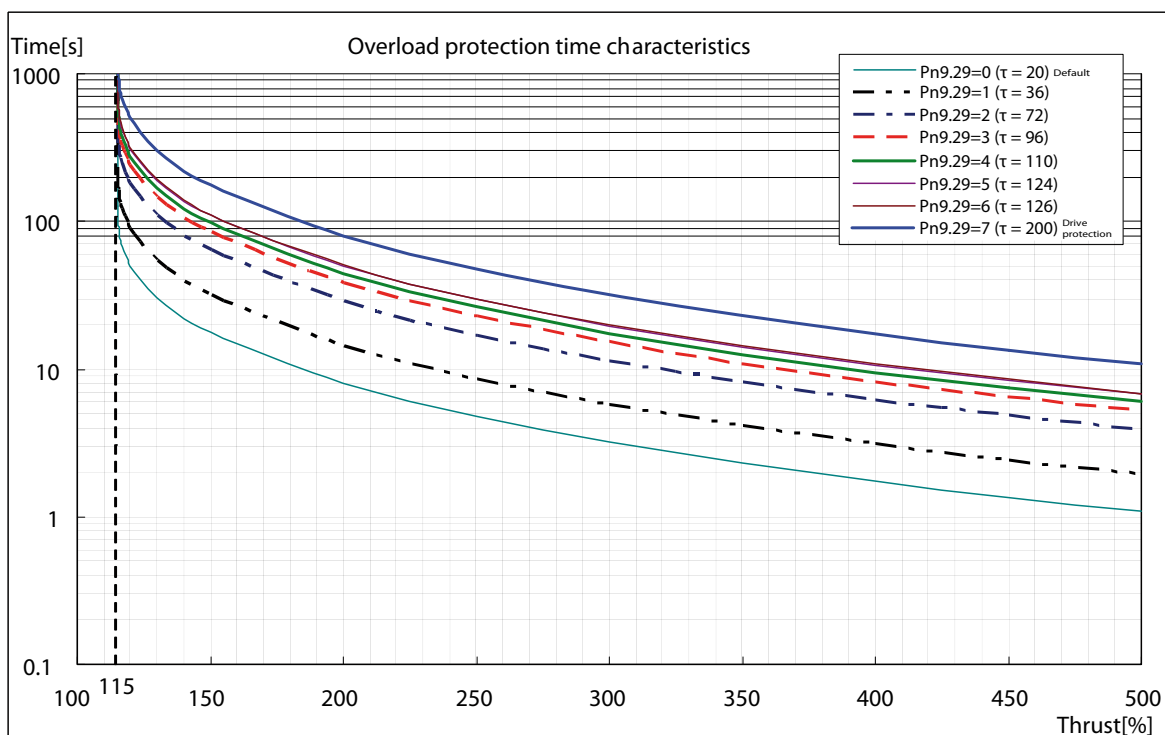

Note: Pn929=0 means that the overload curve is disabled (the overload protection for the servodrive itself is used). In this case, you have to protect the motor by using the internal thermal resistors.

Note: Pn929=7 corresponds to the overload curve for the drive protection.

When the force command = 0, and a constant force command is continuously applied after 3 or more times the overload time constant has elapsed, the overload time t [s] will be:

$$t \text{ [s]} = -\text{Overload time constant [s]} \times \log_e \left(1 - \frac{\text{Overload level [\%]} - \text{Force command [\%]}}{\text{Force command [\%]}} \right)^2$$

(The overload time constant [s] depends on the motor. The standard overload level is 115%.)

3-3 Motor Specifications

There are two families of Lineal Servomotors, F-type for high speed and medium-high Force range and G-type for application with the highest dynamics and accuracy.

A Linear motor consists in a motor coil that, generally, is the moving part, and some linear magnets.

The coil includes temperature sensors and can be ordered with or without connectors.

It is also possible to install an optional hall sensor in the motor coil.

Select the Linear Servomotor based on the load and the required dynamics.

General Specifications for Iron-core motors

Item	Value
Maximum coil operating temperature	130°C
Maximum magnet temperature	70°C
Ambient humidity	20 to 80% non condensating
Operating and storate atmosphere	No corrosive gases
Insulation class	B
Insulation resistance	500V DC
Dielectric strength	2750V for 1s
Maximum DC bus voltage	560V DC
Temperature protection	1 PTC 110C per-phase in series 1KTY-83/121 Self cooling
Hall sensor	Digital, Optional, needs to be ordered separately

Characteristics for Iron-core motors

R88L-EC-FW-0303/-0306

Item	Unit	R88L-EC-FW-0303	R88L-EC-FW-0306
Maximum speed (100V)	m/s	2,5	2,5
Maximum speed (200V)	m/s	5	5
Maximum speed (400V)	m/s	10	10
Peak force ¹	N	105	210
Peak current ¹	Aeff	3,1	6,1
Continous force ²	N	48	96
Continous current ²	Aeff	1,24	2,4
Motor force constant	N/Aeff	39,7	39,7
BEMF	VDC/m/s	32	32
Motorconstant	N/W ^{0,5}	9,75	13,78
Phase resistance	Ω	5,34	2,68
Phase inductance	mH	34,7	17,4
Electrical time constant	ms	6,5	6,5
Max. cont. power disipation (all coils)	W	32	63
Thermal resistance	K/W	2,20	1,10
Thermal time constant	s	110	110
Magnetic attraction force	N	300	500
Magnet pole pitch	mm	24	24
Weight coil unit ³	Kg	0,47	0,78
Weight magnet track	Kg/m	2,1	2,1
Dimension cooling plate (l x w x h)	mm	238 x 220 x 10	238 x 220 x 10
Basic specifications	Protection methods ⁴	Temperature sensors (KTY-83/121 & PTC 110C), self cooling	
	Hall sensor	Digital (optional)	
	Insulation class	Class B	
	Max. busvoltage	560V DC	
	Insulation resistance	500V DC	
	Di-electric strength	2750V for 1 sec	
	Max. allowable coiltemperature	130°C	
	Ambient humidity	20 bis 80% non-condensing	
	Max. allowable magnet temperature	70°C	

¹ Coil temperature rising by 6K/s.

² Values at 100°C coil temperature and magnets at 25°C. Coil unit must be attached to the given cooling plate sizes in the table.

³ Weight without connector and cable.

⁴ I²t has to be set properly for high current applications.

All other values at 25°C (+/-10%).

3-3 Motor Specifications

R88L-EC-FW-0606/-0609/-0612

Item	Unit	R88L-EC-FW-0606	R88L-EC-FW-0609	R88L-EC-FW-0612
Maximum speed (100V)	m/s	2	2	2
Maximum speed (200V)	m/s	4	4	4
Maximum speed (400V)	m/s	8	8	8
Peak force ¹	N	400	600	800
Peak current ¹	Aeff	10	15	20
Continuous force ²	N	160	240	320
Continuous current ²	Aeff	3,4	5,2	6,9
Motor force constant	N/Aeff	46,5	46,5	46,5
BEMF	VDC/m/s	38	38	38
Motorconstant	N/W ^{0,5}	19,49	23,87	27,57
Phase resistance	Ω	1,83	1,23	0,92
Phase inductance	mH	13,7	9,2	6,9
Electrical time constant	ms	7,5	7,5	7,5
Max. cont. power disipation (all coils)	W	88	131	175
Thermal resistance	K/W	0,78	0,52	0,39
Thermal time constant	s	124	124	124
Magnetic attraction force	N	1020	1420	1820
Magnet pole pitch	mm	24	24	24
Weight coil unit ³	Kg	1,31	1,84	2,37
Weight magnet track	Kg/m	3,8	3,8	3,8
Dimension cooling plate (l x w x h)	mm	250 x 287 x 12	250 x 287 x 12	250 x 287 x 12
Basic specifications	Protection methods ⁴	Temperature sensors (KTY-83/121 & PTC 110C), self cooling		
	Hall sensor	Digital (optional)		
	Insulation class	Class B		
	Max. busvoltage	560V DC		
	Insulation resistance	500V DC		
	Di-electric strength	2750V for 1 sec		
	Max. allowable coiltemperature	130°C		
	Ambient humidity	20 bis 80% non-condensing		
Max. allowable magnet temperature	70°C			

¹ Coil temperature rising by 6K/s.

² Values at 100°C coil temperature and magnets at 25°C. Coil unit must be attached to the given cooling plate sizes in the table.

³ Weight without connector and cable.

⁴ It has to be set properly for high current applications.

All other values at 25°C (+/-10%).

R88L-EC-FW-1112/-1115

Item	Unit	R88L-EC-FW-1112	R88L-EC-FW-1115
Maximum speed (100V)	m/s	1	1
Maximum speed (200V)	m/s	2	2
Maximum speed (400V)	m/s	4	4
Peak force ¹	N	1600	2000
Peak current ¹	Aeff	20	25
Continous force ²	N	608	760
Continous current ²	Aeff	6,5	8,2
Motor force constant	N/Aeff	93,0	93,0
BEMF	VDC/m/s	76	76
Motorconstant	N/W ^{0,5}	41,47	46,37
Phase resistance	Ω	1,6	1,29
Phase inductance	mH	12,8	10,3
Electrical time constant	ms	8	8
Max. cont. power disipation (all coils)	W	279	349
Thermal resistance	K/W	0,23	0,18
Thermal time constant	s	126	126
Magnetic attraction force	N	3640	4440
Magnet pole pitch	mm	24	24
Weight coil unit ³	Kg	4,45	5,45
Weight magnet track	Kg/m	10,5	10,5
Dimension cooling plate (l x w x h)	mm	371 x 330 x 14	371 x 330 x 14
Basic specifications	Protection methods ⁴	Temperature sensors (KTY-83/121 & PTC 110C), self cooling	
	Hall sensor	Digital (optional)	
	Insulation class	Class B	
	Max. busvoltage	560V DC	
	Insulation resistance	500V DC	
	Di-electric strength	2750V for 1 sec	
	Max. allowable coiltemperature	130°C	
	Ambient humidity	20 bis 80% non-condensing	
	Max. allowable magnet temperature	70°C	

¹ Coil temperature rising by 6K/s.

² Values at 100°C coil temperature and magnets at 25°C. Coil unit must be attached to the given cooling plate sizes in the table.

³ Weight without connector and cable.

⁴ I²t has to be set properly for high current applications.

All other values at 25°C (+/-10%).

Speed-Force for Iron-core motors

R88L-EC-FW-0303

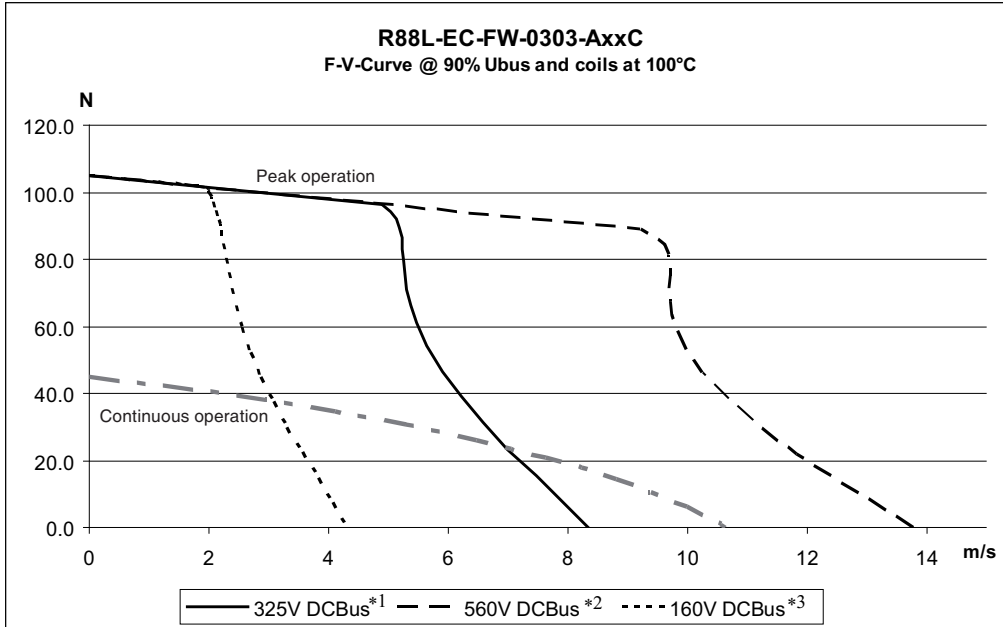

R88L-EC-FW-0306

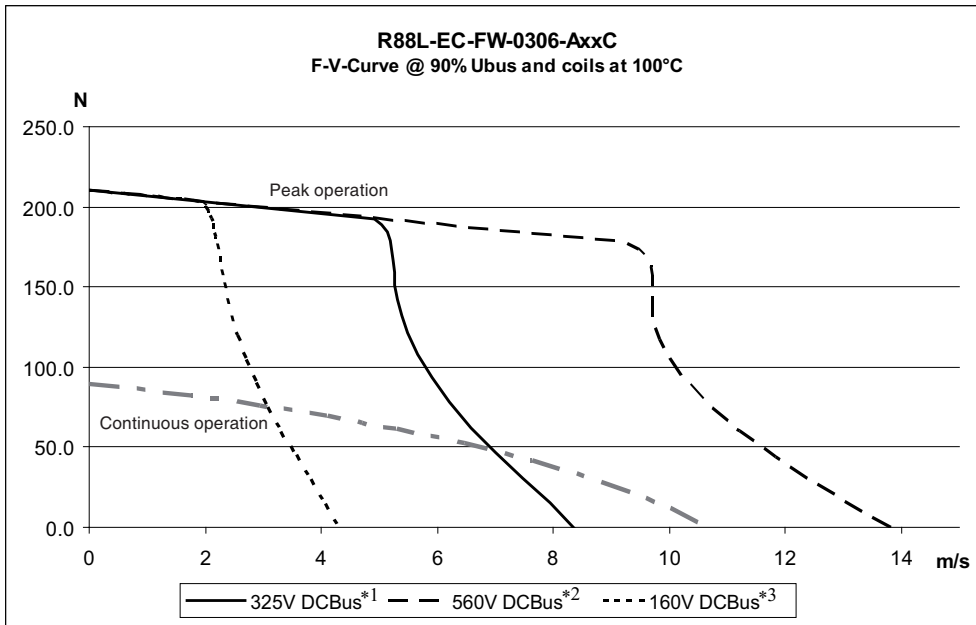

Specifications

R88L-EC-FW-0606

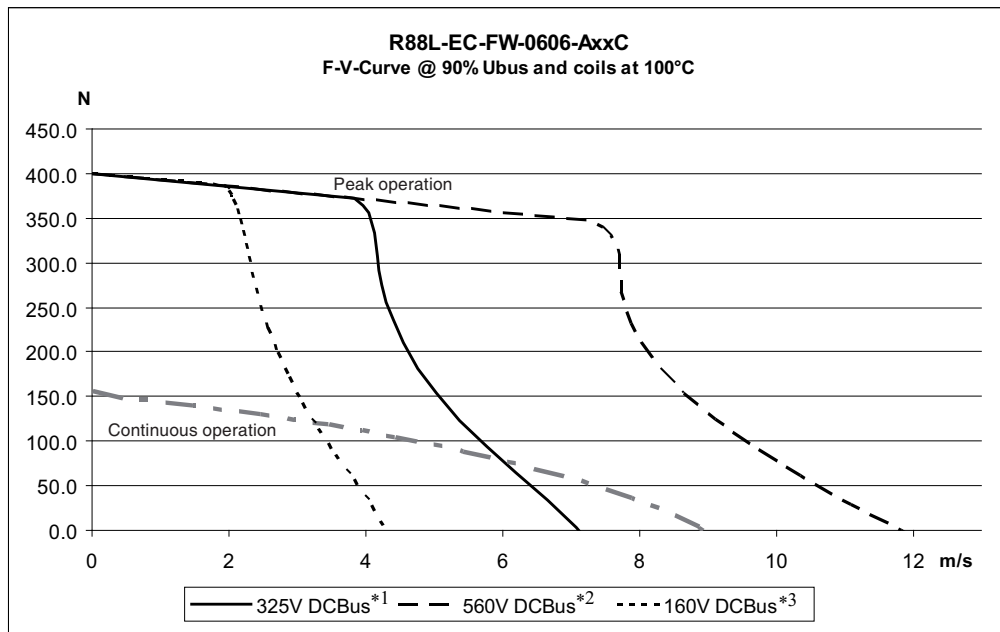

R88L-EC-FW-0609

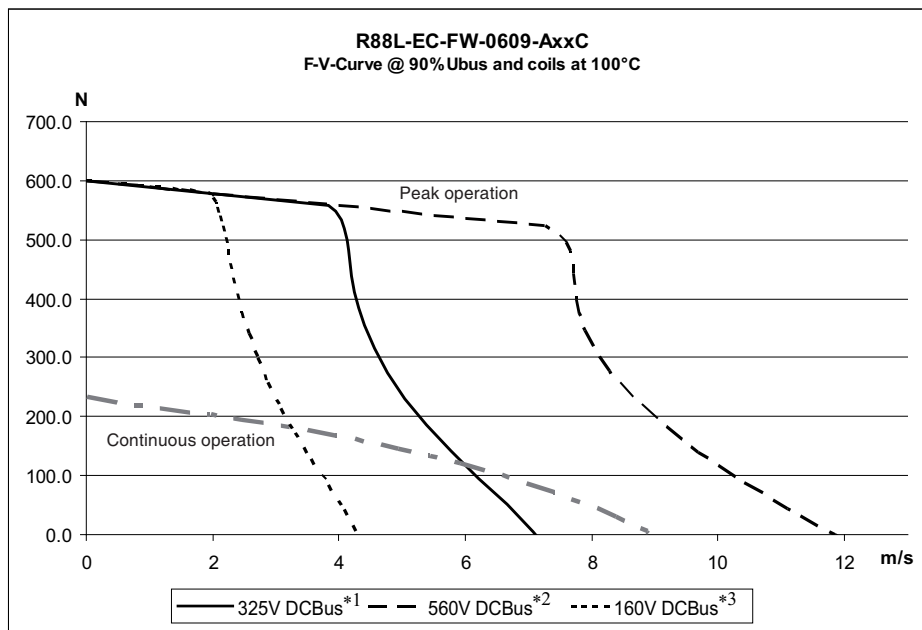

R88L-EC-FW-0612

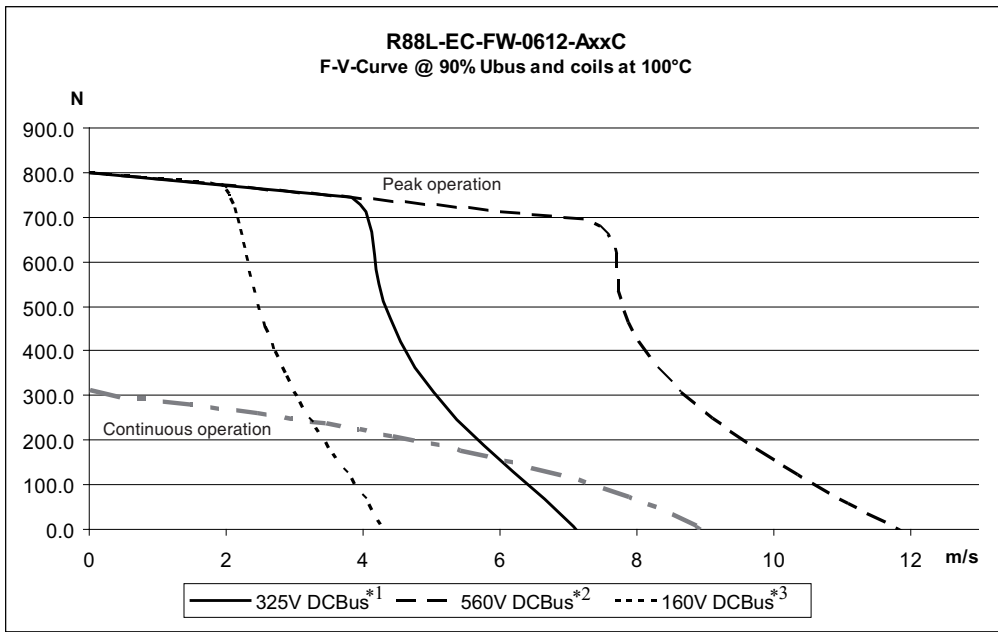

R88L-EC-FW-1112

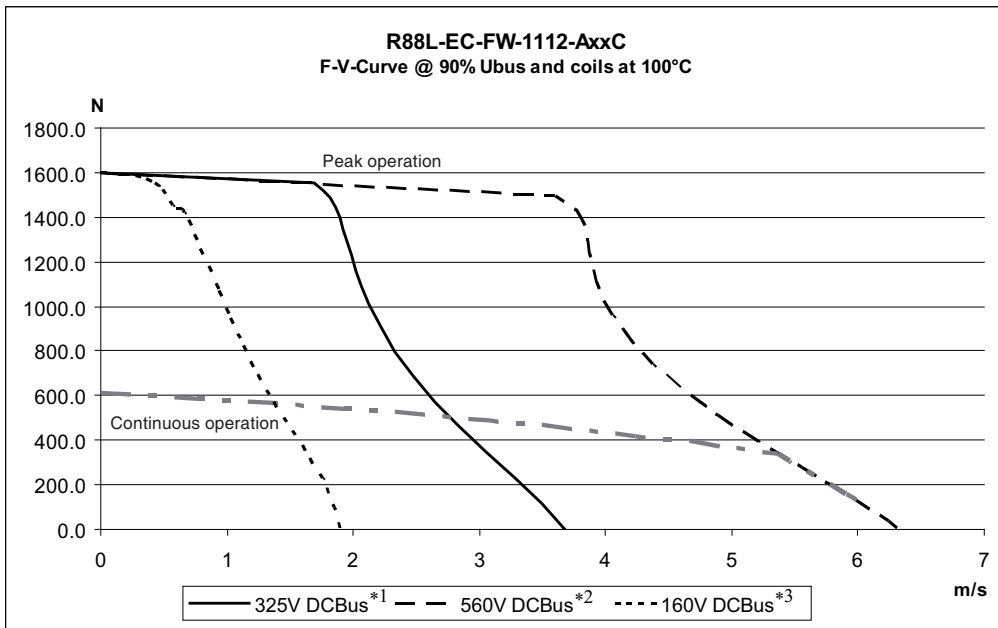

R88L-EC-FW-1115

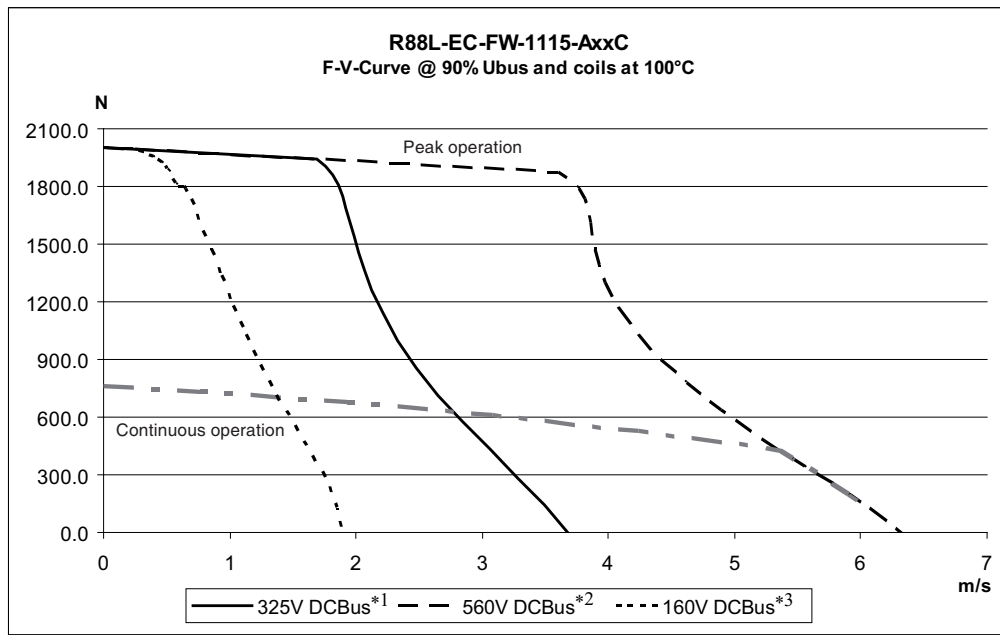

*1 The DCBus voltage corresponds to an AC voltage input (V_{ACIN}) of 235V or more.

*2 The DCBus voltage corresponds to an AC voltage input (V_{ACIN}) of 400V or more.

*3 The DCBus voltage corresponds to an AC voltage input (V_{ACIN}) of 115V or more.

Note: The DCBus value is calculated from the below formula:

$$DCBuS = V_{ACIN} \times \sqrt{2} - \Delta V$$

Temperature sensor specification for Iron-core motors

The Iron-core Linear motors have 1 PTC-110C resistor in each phase that are connected in series. The resistance increases dramatically around 110°C so, this can be used as a switch to stop the motor if the coil become too hot.

In addition also has a KTY-83/121 resistor that allows to measure the average coil temperature.

The resistance versus temperature graphs are next:

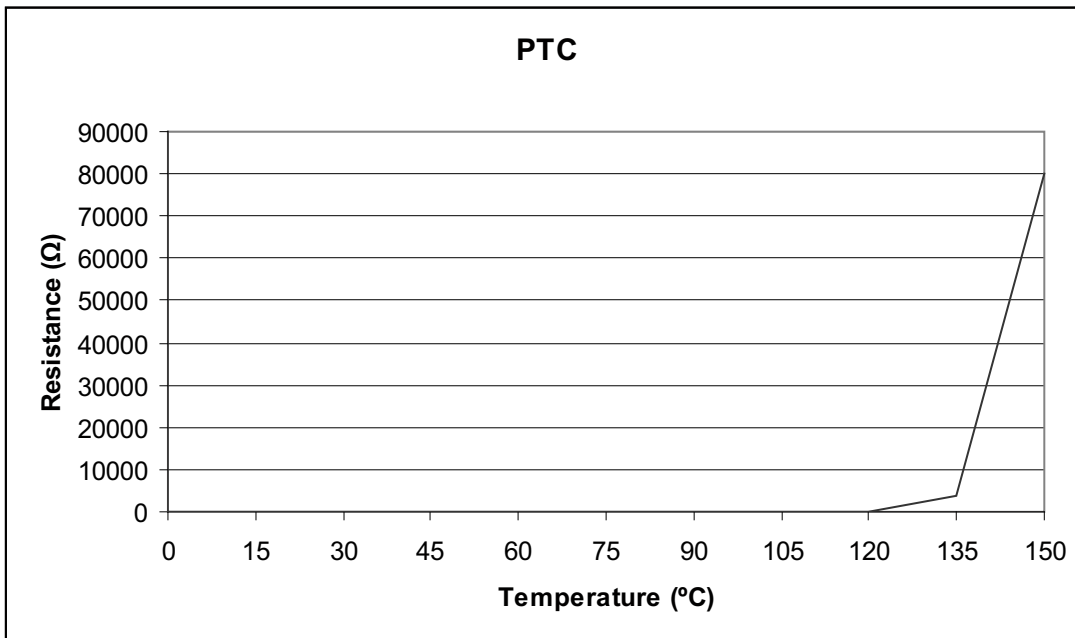
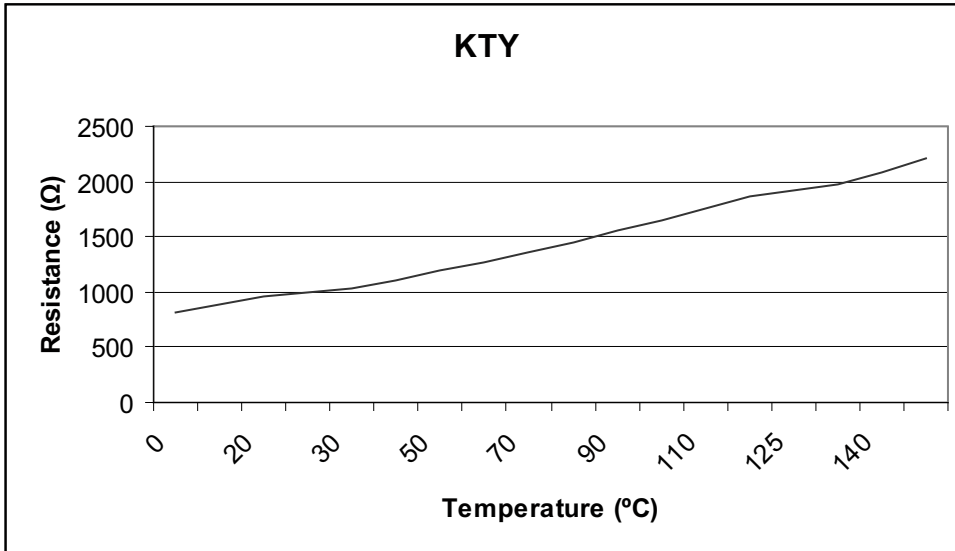

Note: When using a serial converter, the temperature sensors can be connected to it so the temperature alarm is managed in the drive. When not using serial converter, the temperature protection must be managed externally by the controller.

General Specifications for Ironless motors

Item	Value
Maximum coil operating temperature	110°C
Maximum magnet temperature	70°C
Ambient humidity	20 to 80% non condensating
Operating and storage atmosphere	No corrosive gases
Insulation class	B
Insulation resistance	500V DC
Dielectric strength	2250V for 1s
Maximum DC bus voltage	325V DC
Temperature protection	1 PTC 110C 1NTC10k Self cooling
Hall sensor	Digital, Optional, needs to be ordered separately

Characteristics for Ironless motors

R88L-EC-GW-0303/-0306/-0309

Item	Unit	R88L-EC-GW-0303	R88L-EC-GW-0306	R88L-EC-GW-0309
Maximum speed (100V)	m/s	8	8	8
Maximum speed (200V)	m/s	16	16	16
Peak force ¹	N	100	200	300
Peak current ¹	Aeff	5,0	10,0	15,0
Continous force ²	N	26,5	53	80
Continous current ²	Aeff	1,33	2,66	4,0
Motor force constant	N/Aeff	19,9	19,9	19,9
BEMF	VDC/m/s	16,0	16,0	16,0
Motorconstant	N/W ^{0,5}	4,90	6,93	8,43
Phase resistance	Ω	5,5	2,8	1,8
Phase inductance	mH	1,8	0,9	0,6
Electrical time constant	ms	0,35	0,35	0,35
Max. cont. power disipation (all coils)	W	47	95	142
Thermal resistance	K/W	2,1	1,06	0,71
Thermal time constant	s	36	36	36
Magnetic attraction force	N	0	0	0
Magnet pole pitch	mm	30	30	30
Weight coil unit ³	Kg	0,084	0,138	0,198
Weight magnet track	Kg/m	4,8	4,8	4,8
Basic specifications	Protection methods ⁴	Temperature sensors NTC10k, PTC110C, self cooling		
	Hall sensor	Digital (optional)		
	Insulation class	Class B		
	Max. busvoltage	325V DC		
	Insulation resistance	500V DC		
	Di-electric strength	2250V for 1 sec		
	Max. allowable coiltemperature	110°C		
	Ambient humidity	20 - 80% non-condensing		
	Max. allowable magnet temperature	70°C		

¹ Coil temperature rising 03-series by 40K/s, 05-series by 20K/s and 07-series by 20K/s.

² Values at 110°C coil temperature and magnets at 25°C.

³ Weight without connector and cable.

⁴ I²t has to be set properly for high current overload applications.
All other values at 25°C (+/-10%).

R88L-EC-GW-0503/-0506/-0509

Item	Unit	R88L-EC-GW-0503	R88L-EC-GW-0506	R88L-EC-GW-0509
Maximum speed (100V)	m/s	2,2	2,2	2,2
Maximum speed (200V)	m/s	4,4	4,4	4,4
Peak force ¹	N	240	480	720
Peak current ¹	Aeff	3,50	7,1	10,6
Continous force ²	N	58	117	175
Continous current ²	Aeff	0,87	1,76	2,60
Motor force constant	N/Aeff	68,0	68,0	68,0
BEMF	VDC/m/s	55,5	55,5	55,5
Motorconstant	N/W ^{0,5}	9,85	13,96	17,03
Phase resistance	Ω	15,9	8,0	5,3
Phase inductance	mH	13,0	6,5	4,2
Electrical time constant	ms	0,8	0,8	0,8
Max. cont. power disipation (all coils)	W	67	134	200
Thermal resistance	K/W	1,70	0,85	0,65
Thermal time constant	s	72	72	72
Magnetic attraction force	N	0	0	0
Magnet pole pitch	mm	42	42	42
Weight coil unit ³	Kg	0,250	0,470	0,690
Weight magnet track	Kg/m	11,2	11,2	11,2
Basic specifications	Protection methods ⁴	Temperature sensors NTC10k, PTC110C, self cooling		
	Hall sensor	Digital (optional)		
	Insulation class	Class B		
	Max. busvoltage	325V DC		
	Insulation resistance	500V DC		
	Di-electric strength	2250V for 1 sec		
	Max. allowable coiltemperature	110°C		
	Ambient humidity	20 - 80% non-condensing		
	Max. allowable magnet temperature	70°C		

¹ Coil temperature rising 03-series by 40K/s, 05-series by 20K/s and 07-series by 20K/s.

² Values at 110°C coil temperature and magnets at 25°C.

³ Weight without connector and cable.

⁴ I²t has to be set properly for high current overload applications.
All other values at 25°C (+/-10%).

3-3 Motor Specifications

R88L-EC-GW-0703/-0706/-0709

Item	Unit	R88L-EC-GW-0703	R88L-EC-GW-0706	R88L-EC-GW-0709
Maximum speed (100V)	m/s	1,2	1,2	1,2
Maximum speed (200V)	m/s	2,4	2,4	2,4
Peak force ¹	N	700	1400	2100
Peak current ¹	Aeff	5,6	11,3	16,9
Continuous force ²	N	117	232	348
Continuous current ²	Aeff	0,94	1,87	2,81
Motor force constant	N/Aeff	124,0	124,0	124,0
BEMF	VDC/m/s	101,0	101,0	101,0
Motorconstant	N/W ^{0,5}	17,97	25,44	31,14
Phase resistance	Ω	15,8	7,9	5,3
Phase inductance	mH	28,0	14,0	9,0
Electrical time constant	ms	1,8	1,8	1,8
Max. cont. power disipation (all coils)	W	82	165	247
Thermal resistance	K/W	1,56	1,04	0,52
Thermal time constant	s	96	96	96
Magnetic attraction force	N	0	0	0
Magnet pole pitch	mm	57	57	57
Weight coil unit ³	Kg	0,550	0,950	1,350
Weight magnet track	Kg/m	24	24	24
Basic specifications	Protection methods ⁴	Temperature sensors NTC10k, PTC110C, self cooling		
	Hall sensor	Digital (optional)		
	Insulation class	Class B		
	Max. busvoltage	325V DC		
	Insulation resistance	500V DC		
	Di-electric strength	2250V for 1 sec		
	Max. allowable coiltemperature	110°C		
	Ambient humidity	20 - 80% non-condensing		
	Max. allowable magnet temperature	70°C		

¹ Coil temperature rising 03-series by 40K/s, 05-series by 20K/s and 07-series by 20K/s.

² Values at 110°C coil temperature and magnets at 25°C.

³ Weight without connector and cable.

⁴ i^2t has to be set properly for high current overload applications.
All other values at 25°C (+/-10%).

Speed-Force for Ironless motors

R88L-EC-GW-0303

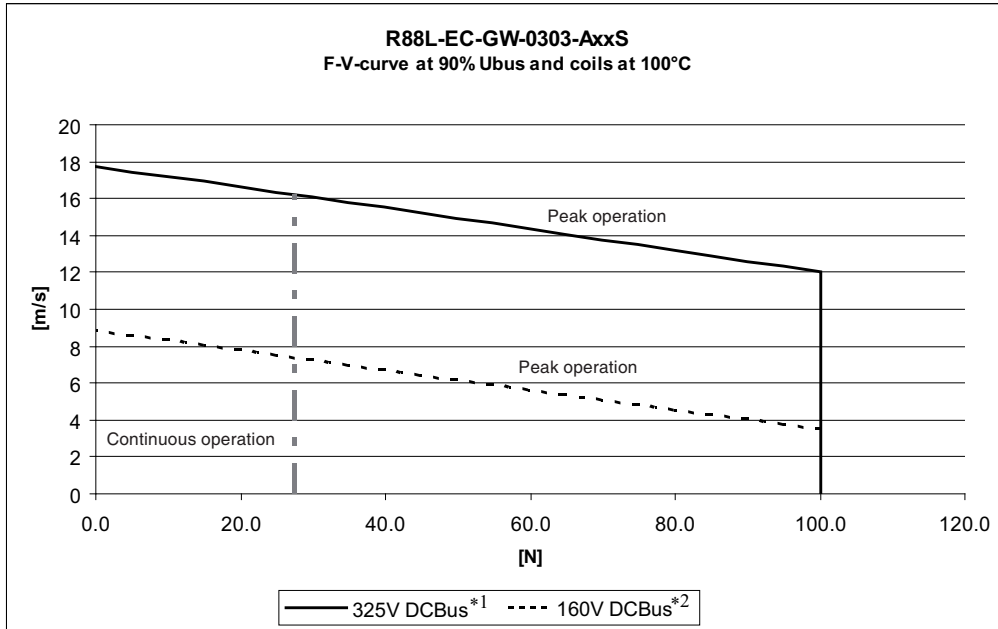

R88L-EC-GW-0306

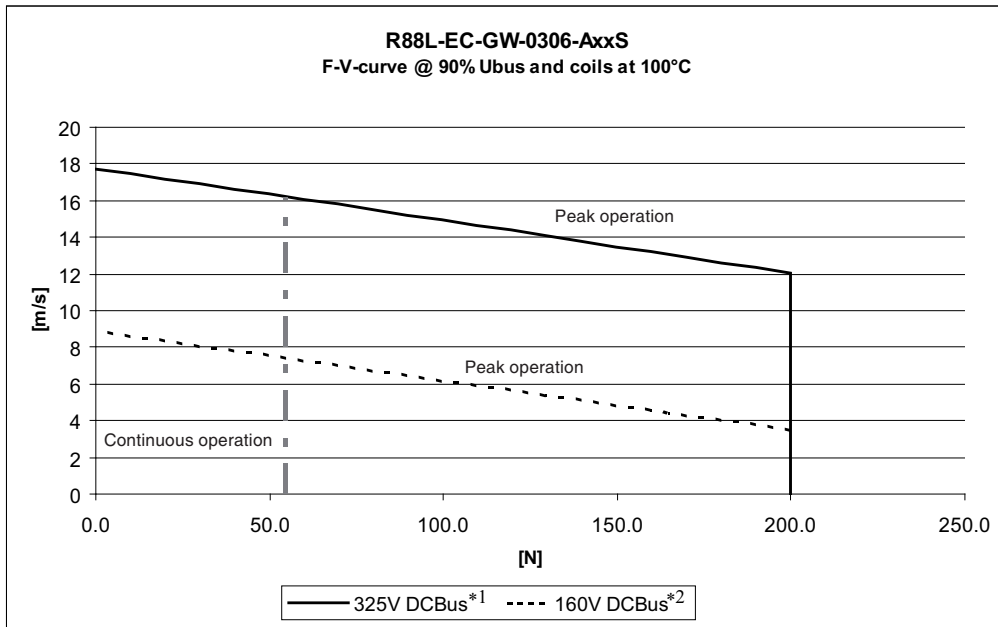

Specifications

R88L-EC-GW-0309

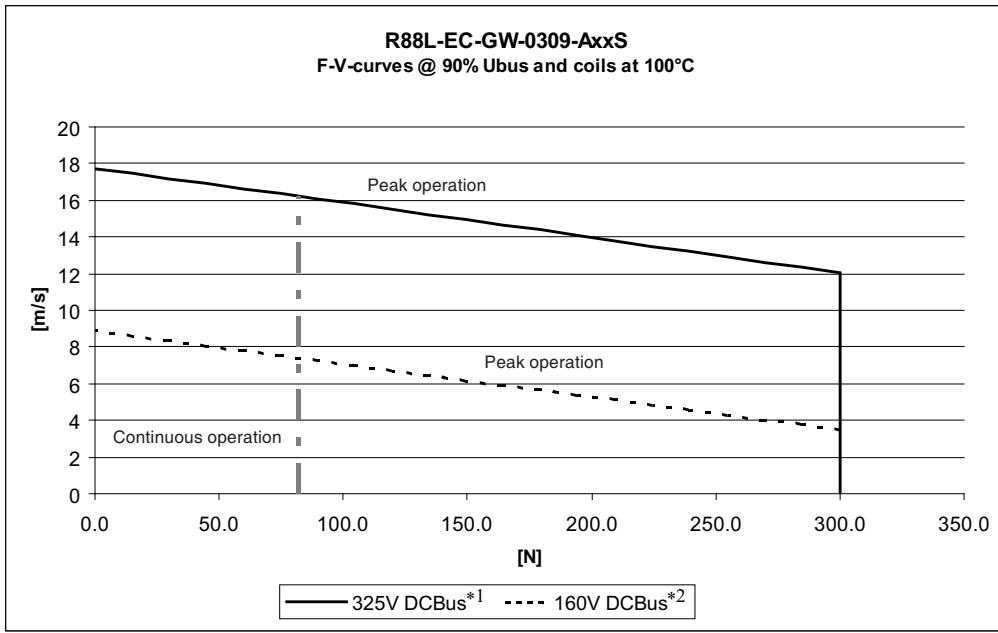

R88L-EC-GW-0503

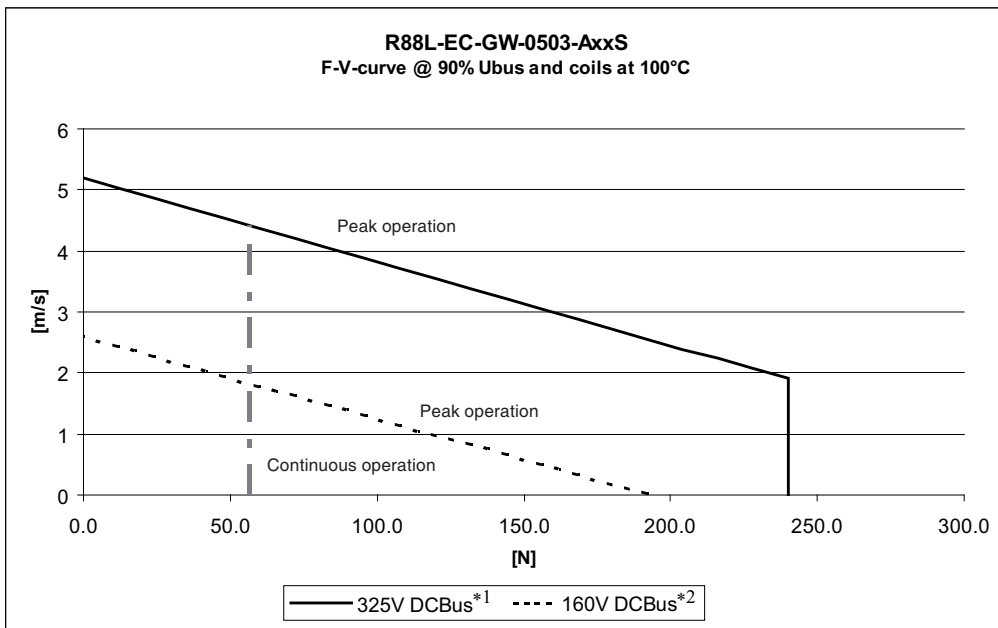

R88L-EC-GW-0506

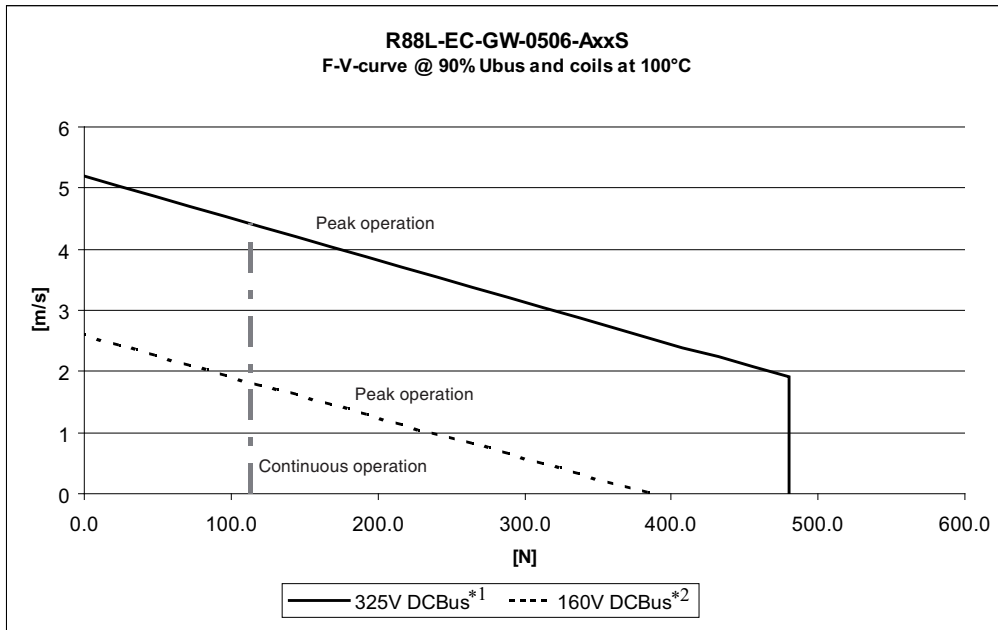

R88L-EC-GW-0509

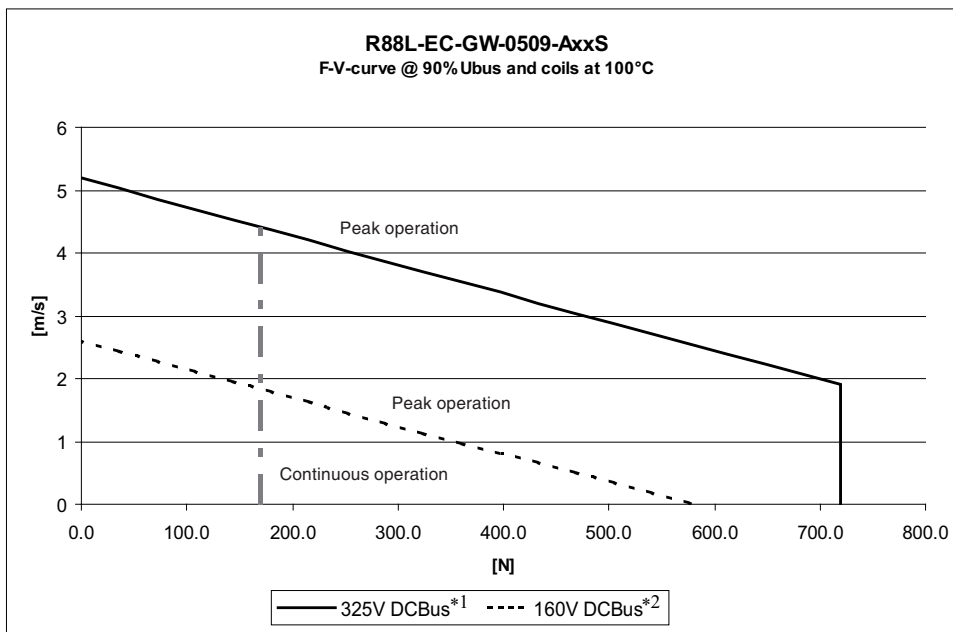

R88L-EC-GW-0703

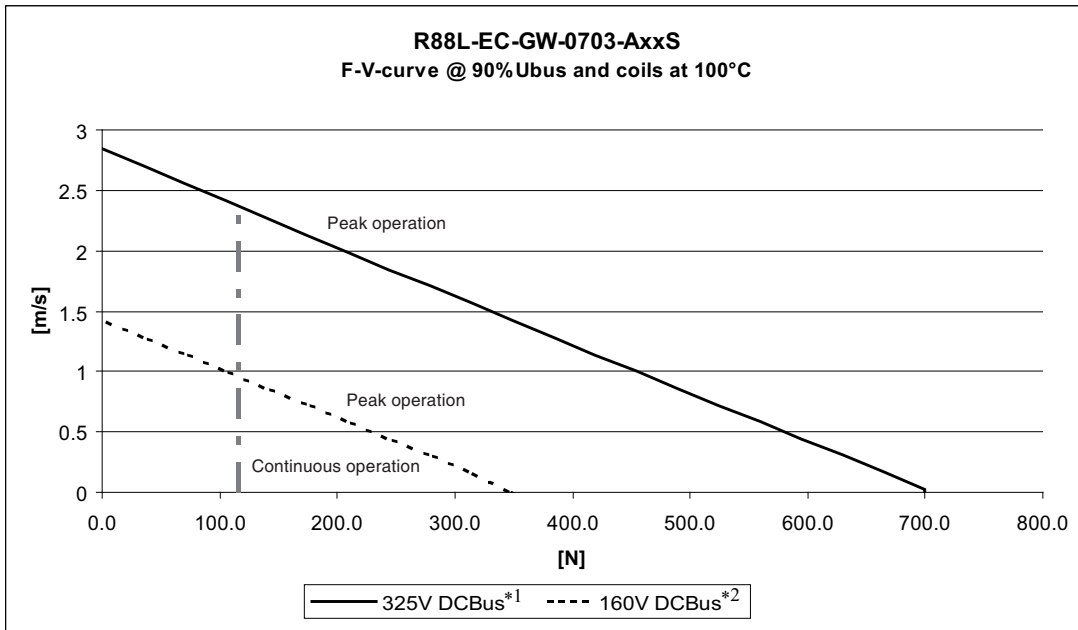

R88L-EC-GW-0706

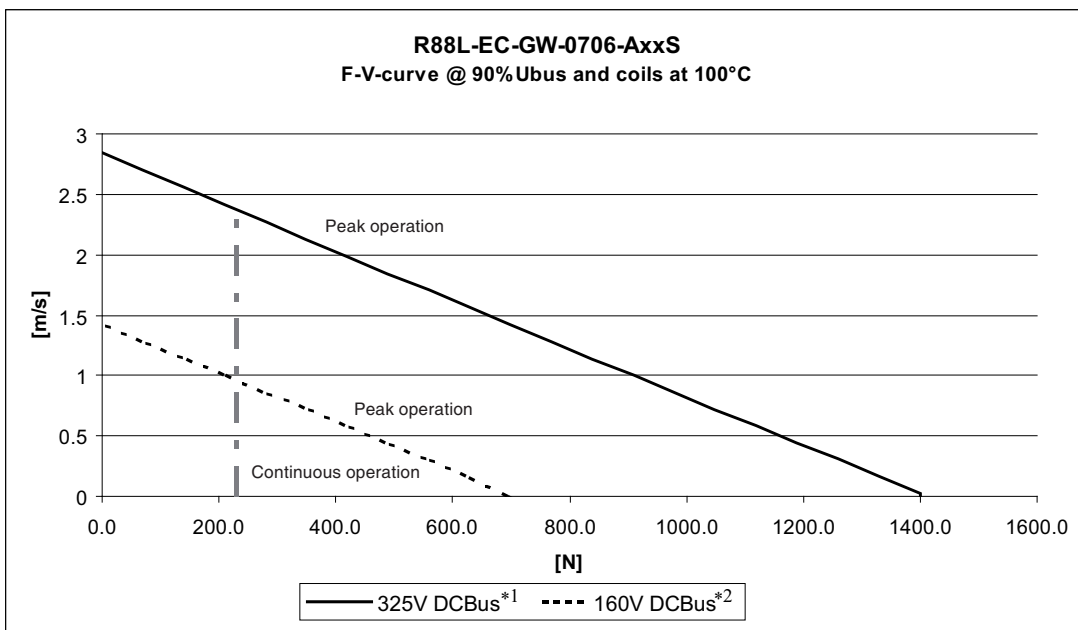

Specifications

R88L-EC-GW-0709

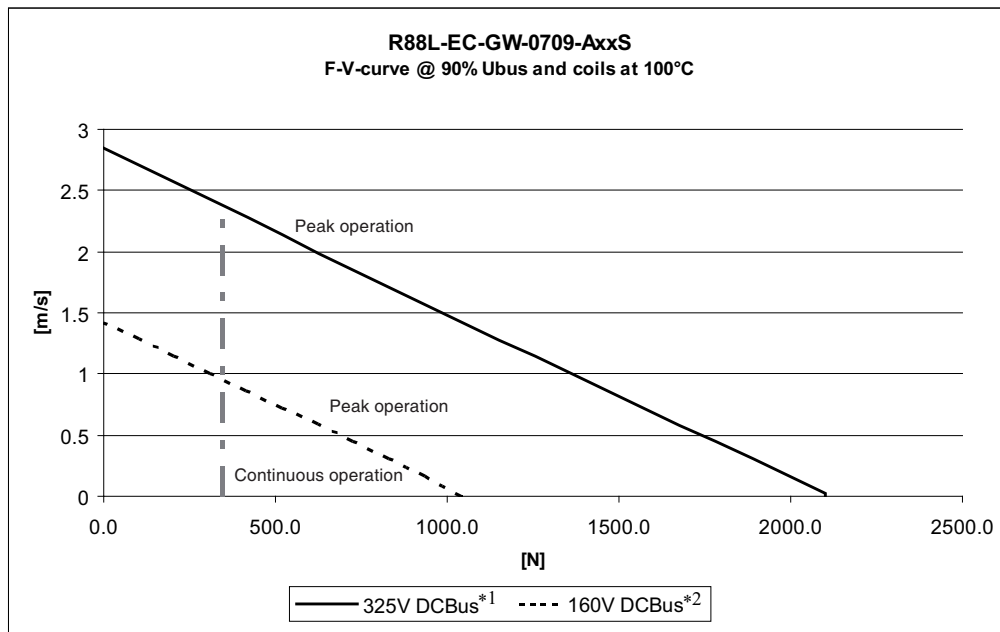

*1 The DCBus voltage corresponds to an AC voltage input (V_{ACIN}) of 235V or more.

*2 The DCBus voltage corresponds to an AC voltage input (V_{ACIN}) of 115V or more.

Note: The DCBus value is calculated from the below formula:

$$DCBuS = V_{ACIN} \times \sqrt{2} - \Delta V$$

Temperature sensor specification for Ironless motors

The Ironless Linear motors have 1 PTC-110C resistor for all. The resistance increases dramatically around 110°C so, this can be used as a switch to stop the motor if the coil become too hot.

In addition also has a NTC10K resistor that allows to measure the average coil temperature. The resistance versus temperature graphs are next:

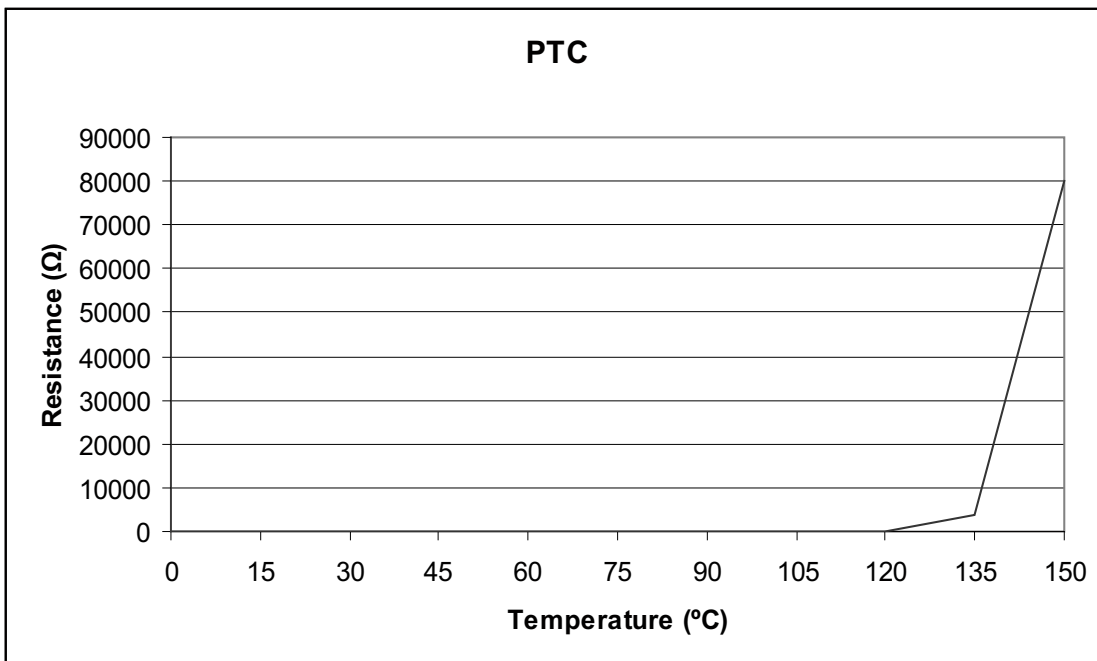
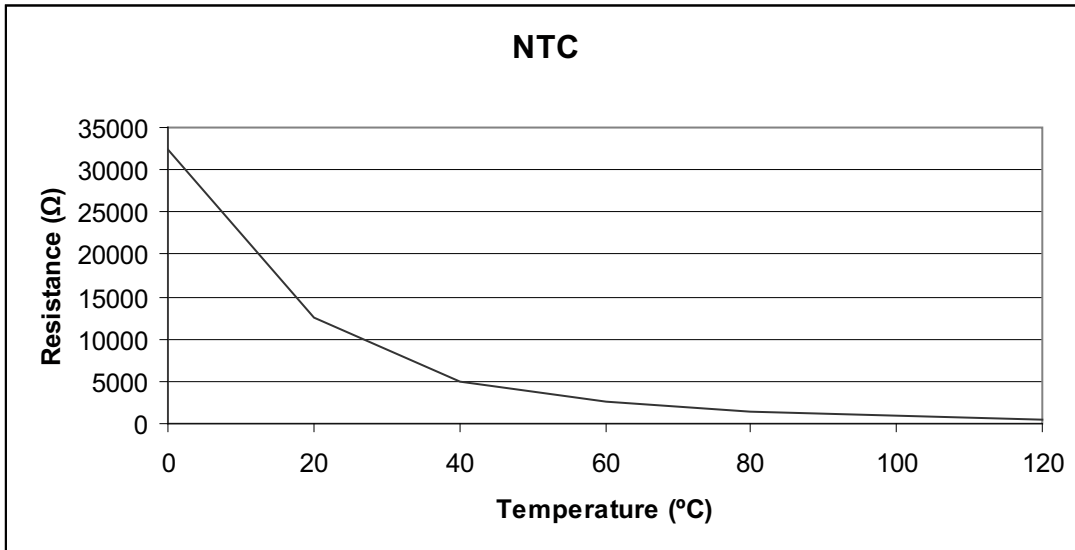

Note: When using a serial converter, the temperature sensors can be connected to it so the temperature alarm is managed in the drive. When not using serial converter, the temperature protection must be managed externally by the controller.

Temperature Characteristics of the Motor and Mechanical System

- ♦ OMNUC G5-Linear Series AC Servomotors use rare earth magnets (neodymium-iron magnets). The temperature coefficient for these magnets is approx. $-0.13\%/^{\circ}\text{C}$. As the temperature drops, the motor's momentary maximum force increases, and as the temperature rises, the motor's momentary maximum force decreases.
- ♦ The momentary maximum force rises by 4% at a normal temperature of 20°C compared to a temperature of -10°C . Conversely, the momentary maximum force decreases about 8% when the magnet warms up to 70°C from the normal temperature.
- ♦ Generally, when the temperature drops in a mechanical system, the friction force and the load force increase. For that reason, overloading may occur at low temperatures. In particular, in systems that use a gearbox, the load force at low temperatures may be nearly twice as much as the load force at normal temperatures. Check whether overloading may occur during starting at low temperature. Also check to see whether abnormal motor overheating or alarms occur at high temperatures.
- ♦ An increase in load friction force seemingly increases load mass. Therefore, even if the drive gains are adjusted at a normal temperature, the motor may not operate properly at low temperatures. Check to see whether there is optimal operation even at low temperatures.

3-4 Encoder, Hall sensor and Serial Converter

A/B Incremental Encoder Specifications

Specifications

A, B & Z line-drive differential inputs with 90° phase difference signals.
 Maximum frequency is 1Mpps before x4 interpolation (or 4MHz after interpolation).

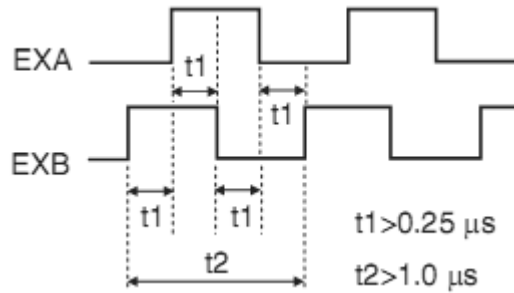

To use this encoder set Pn3.23=0 (default setting).

Choose an encoder with the required $\mu\text{m}/\text{pulse}$ to match the required resolution and maximum speed. It is recommended to use encoders with 20 $\mu\text{m}/\text{pulse}$ (5 μm resolution).

Counting direction

The counting direction of the feedback encoder follows the next criteria.

Positive direction	Negative direction
<p>EXB is advancement from EXA by 90°.</p> <p>$t1 > 0.25\mu\text{s}$</p> <p>$t2 > 1.0\mu\text{s}$</p>	<p>EXB is a delay from EXA by 90°.</p> <p>$t1 > 0.25\mu\text{s}$</p> <p>$t2 > 1.0\mu\text{s}$</p>

The direction of the feedback encoder must correspond with the direction of the motor coil phases. If not you can reverse the count direction with parameter Pn3.26 (=0 direction is not reversed, =1 direction is reversed).

You can measure the direction of the motor phases using the next method:

- Connect an oscilloscope between the motor phases: U-W, V-U AND W-V.
- Disconnect the motor phases from the Linear Servo Drive.
- Move the motor coil with your hand and measure the induced voltage.

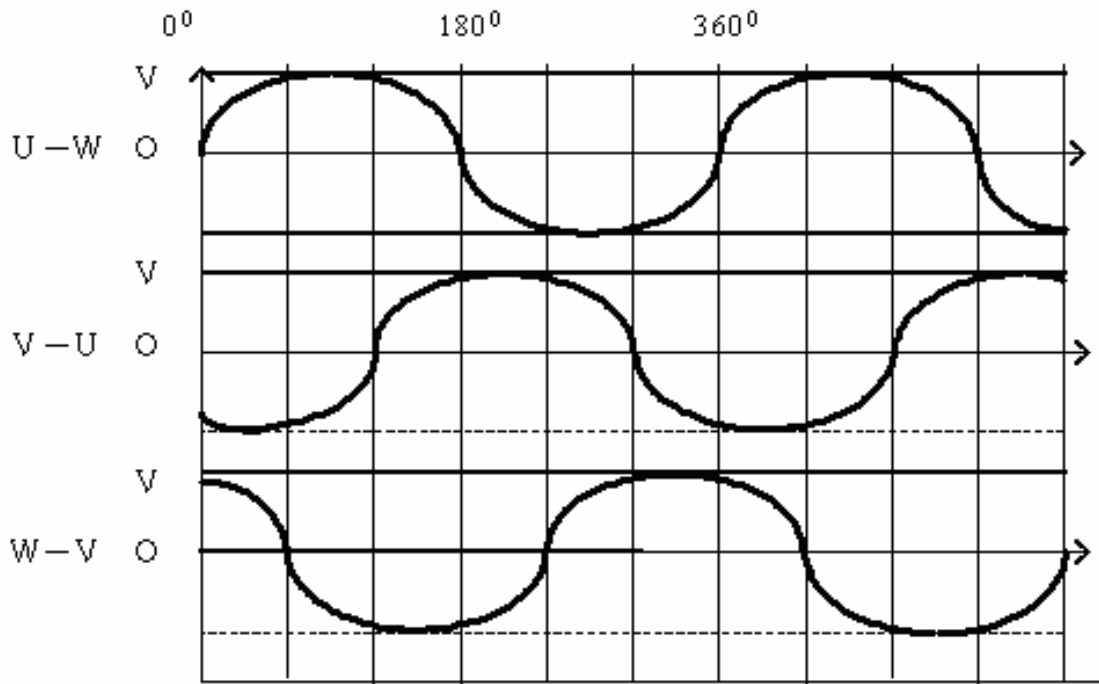

**In this direction the feedback encoder must count negative,
otherwise you must reverse the counting direction.**



The positive direction of the motor phases is towards the output cable side.

Connection to the drive

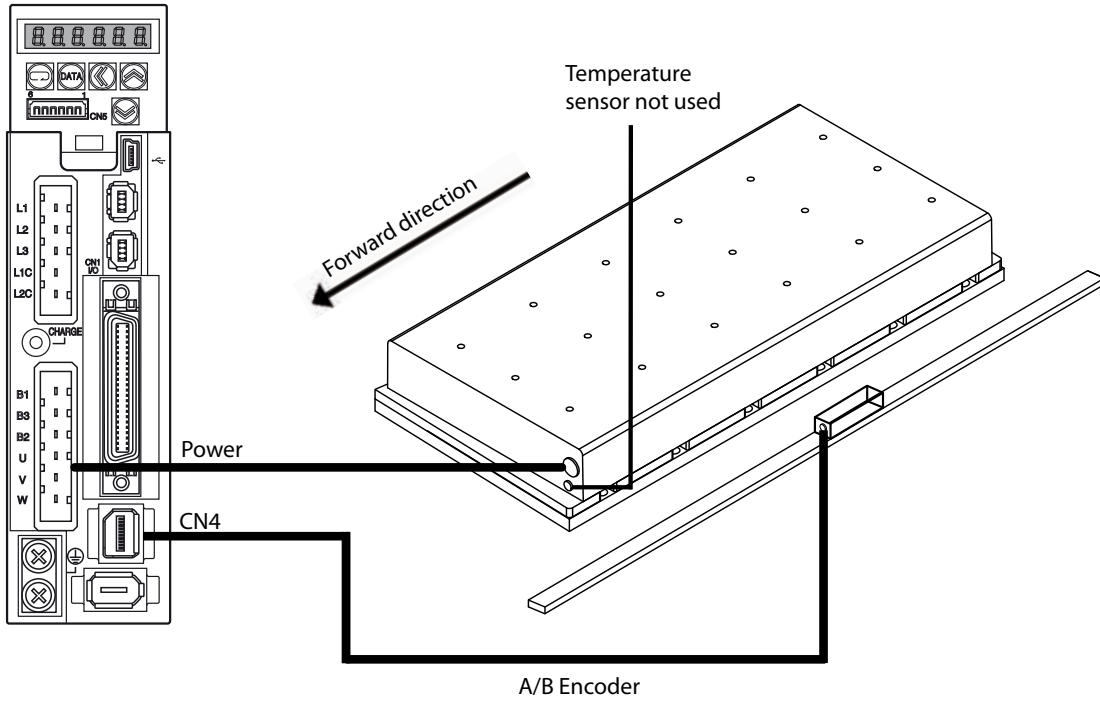

Specifications

SinCos Encoder Specifications

Specifications

The following figure shows the input timing of the analog signals.

The specifications of the cos, /cos, sin, and /sin signals are identical except for the phase.

Input the signals Ref and /Ref so that they shall cross each other as shown in the figure because they are input into the converter. When they are crossed, the output data will be counted up.

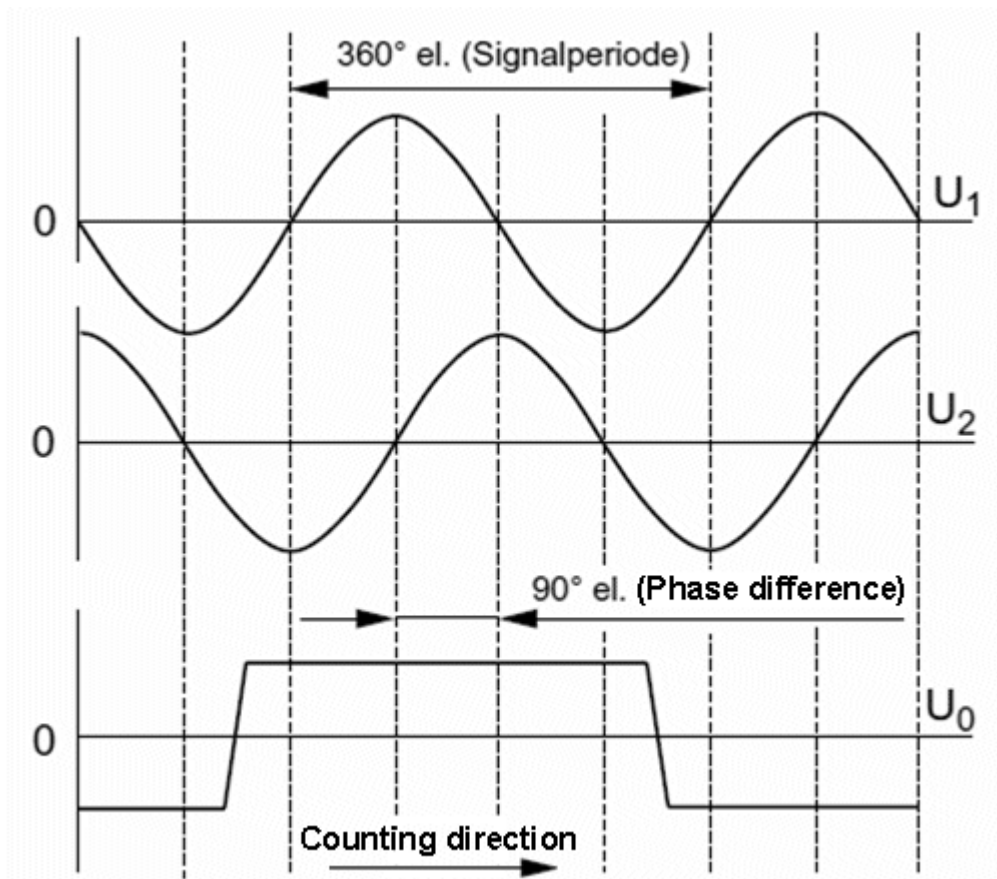

Max. frequency: 400KHz.

This is the positive counting direction including the reference pulse signal.

Difference signals measured at R_0 :

$U_1: U_{1+} - U_{1-} = 0,6 \dots 1,2V_{SS}$ (Nominal voltage: $1V_{SS}$)

$U_2: U_{2+} - U_{2-} = 0,6 \dots 1,2V_{SS}$ (Nominal voltage: $1V_{SS}$)

$U_0: U_{0+} - U_{0-} = 0,5 \dots 1,2V$ (Nominal voltage: $0,8V$)

Counting direction

The direction of the feedback encoder must correspond with the direction of the motor coil phases. If not you can reverse the count direction with parameter Pn326 (=0 direction is not reversed, =1 direction is reversed).

You can measure the direction of the motor phases using the next method:

- Connect an oscilloscope between the motor phases: U-W, V-U AND W-V.
- Disconnect the motor phases from the Linear Servo Drive.
- Move the motor coil with your hand and measure the induced voltage.

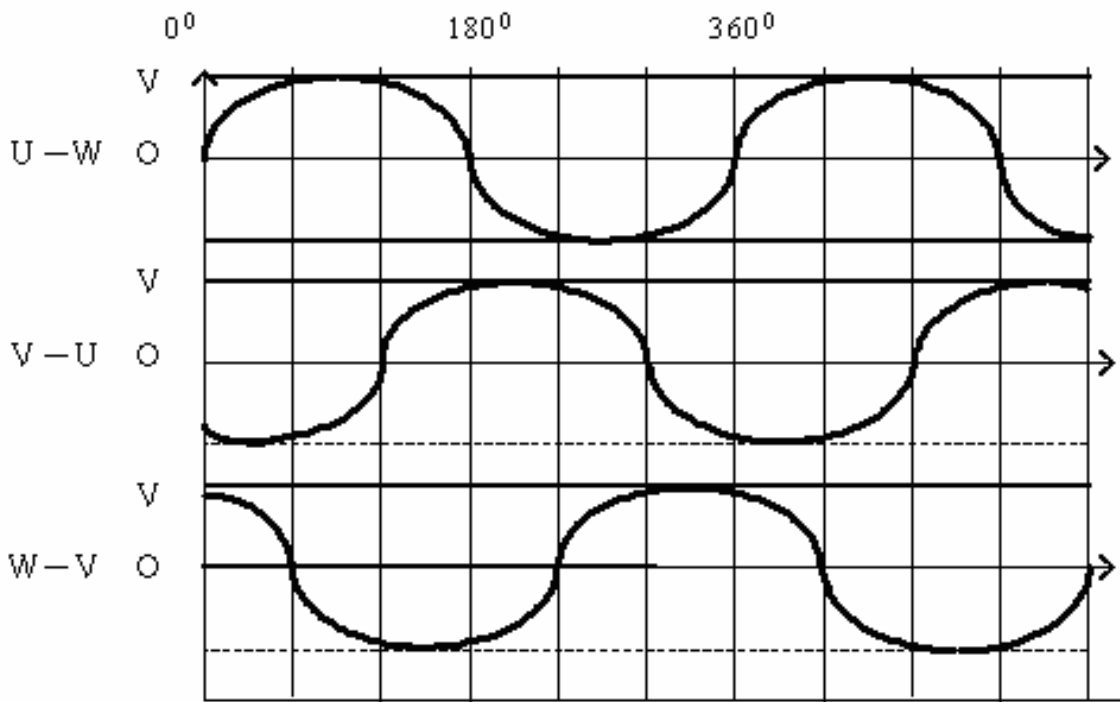

In this direction the feedback encoder must count negative, otherwise you must reverse the counting direction.

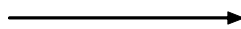

The positive direction of the motor phases is towards the output cable side.

Specifications

Connection to the drive

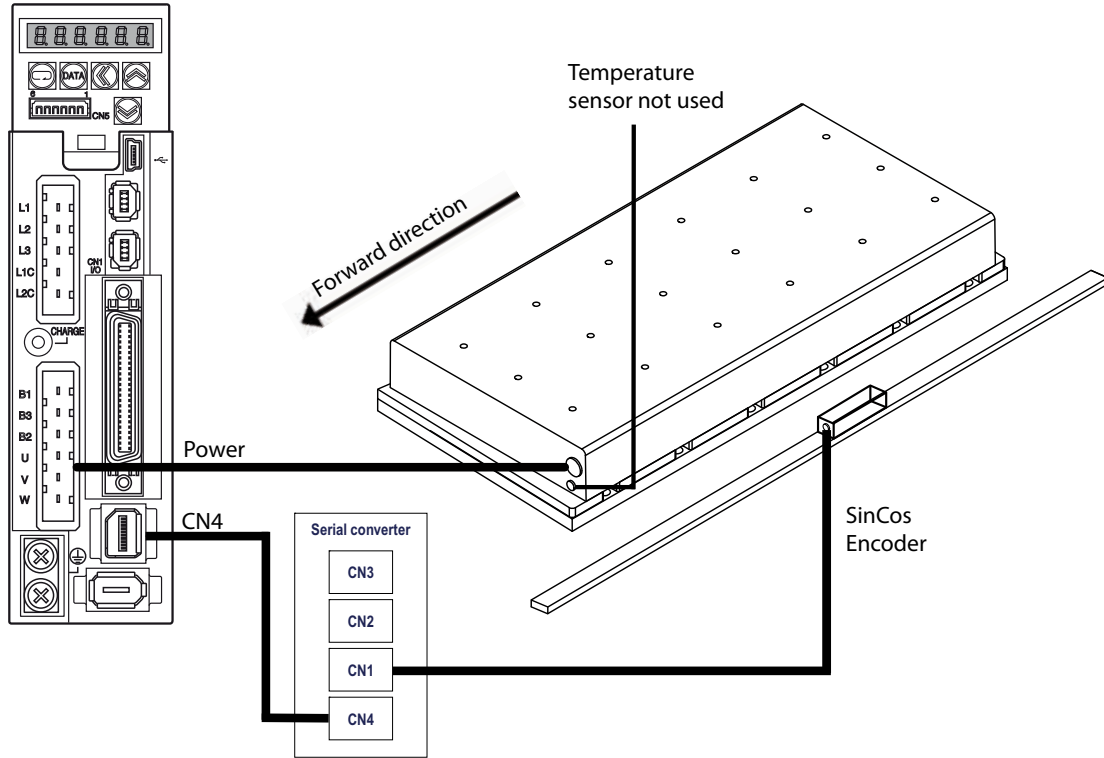

Hall Sensor Specifications

Specifications

The Hall Sensor can be optionally installed in the motor coil to have a direct measurement of the motor phase angle respect to the magnets.

The Hall Sensor must be installed in the motor coil and connected to the drive through the Serial Converter (CN2 connector).

To use the Hall Sensor it is necessary next settings:

Pn 3.23= 1 To use Serial Converter. That means that the Hall sensor has to be used in combination with the Serial Encoder

Pn 9.20= 1 To read the motor phases from the Hall Sensor

Electric data:

Supply: 4 to 28V DC, 25mA

TTL outputs 2mA per channel

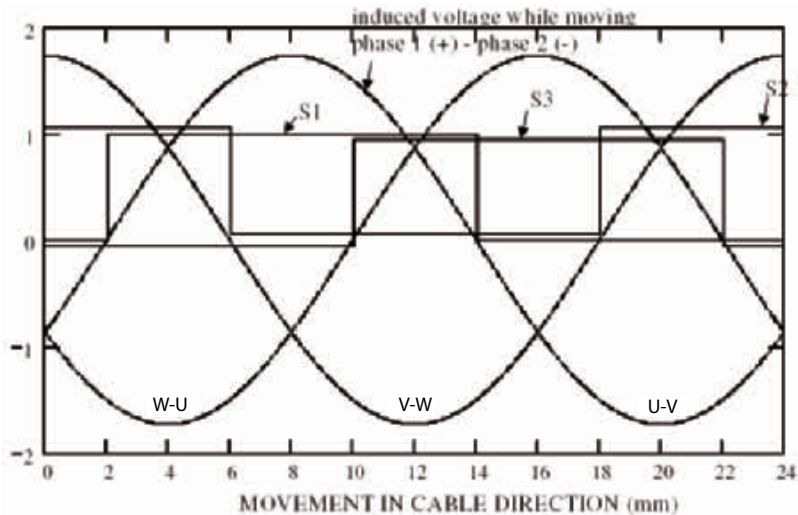

Connector: DB9 male

Signal	Color	Pin
GND	Black	5
5V DC supply	Brown	1
S1	Yellow	2
S2	Green	3
S3	Orange	4

Name	Applicable Motors
R88L-EC-FH-NNNN-A	R88L-EC-FW-[] [] []
R88L-EC-GH-03NN-A	R88L-EC-GW-03 [] []
R88L-EC-GH-05NN-A	R88L-EC-GW-05 [] []
R88L-EC-GH-07NN-A	R88L-EC-GW-07 [] []

Serial Converter Specifications

Specifications

The Serial Converter is a device that reads the SinCos position feedback and, optionally, the Hall Sensor signals and Temperature signals and send the information cyclically to the Linear Servo Drive via the Encoder serial protocol.

The SinCos positional information is interpolated in the Serial Converter by a factor of 400 (before x4 interpolation). As an example, a SinCos Encoder with a pitch of 20 μ m results in a resolution of 50nm. Thus we do not have the limitations in bandwidth that we have with the A/B pulse Encoder and we can reach high speeds with high resolution.

Vibration resistance:	max. 98m/s ² (1 bis 2500Hz) in three direction
Shock resistance:	980m/s ² (11ms) two times in three direction
Working temperature:	0°C to 55°C
Storage temperature:	-20°C to 80°C
Humidity:	20% to 90% relative humidity (non-condensing)
Ingress protection:	IP 40
Conversion delay:	<42 μ s
Standard resolution:	Interpolation factor 100 plus quadrature count
Max. input frequency:	400KHz 1V _{ptp} (before interpolation. 1.6MHz after interpolation)
Power supply:	5V DC, 250mA supplied by the drive

Pinout

Encoder input 1Vpp (CN1)	
Connector D-Sub 15-pin (female) 1Vpp with programmable lines NUMERIK JENA Standard	
PIN	Signal
1	SDA*
2	SCL*
3	-
4	-U ₀
5	-U ₂
6	-U ₁
7	-
8	5V
9	0V
10	-
11	-
12	U ₀
13	U ₂
14	U ₁
15	IS

*Reserved. Please do not use.

Serial interface (CN4)	
Connector D-Sub 15-pin (male)	
PIN	Signal
1	PS
2	/PS
3	-
4	-
5	-
6	-
7	-
8	5V
9	0V
10	-
11	-
12	-
13	-
14	-
15	-

Hall & Temperature sensors interface (CN2)	
Connector D-Sub 9-pin (female)	
PIN	Signal
1	U+
2	Hall U
3	Hall V
4	Hall W
5	GND
6	PTC
7	PTC
8	KTY
9	KTY

Temperature sensor interface without Hall sensor (CN3)	
Connector D-Sub 9-pin (female)	
PIN	Signal
1	-
2	-
3	-
4	-
5	-
6	PTC
7	PTC
8	KTY/NTC
9	KTY/NTC

Note: As the 6, 7, 8, 9 pins in the CN2 and CN3 connectors are internally wired, the temperature sensor can be connected to both connectors. When the hall sensor is also required, use the same cable for hall & temperature signals and the CN2 connector.

Connection to the drive

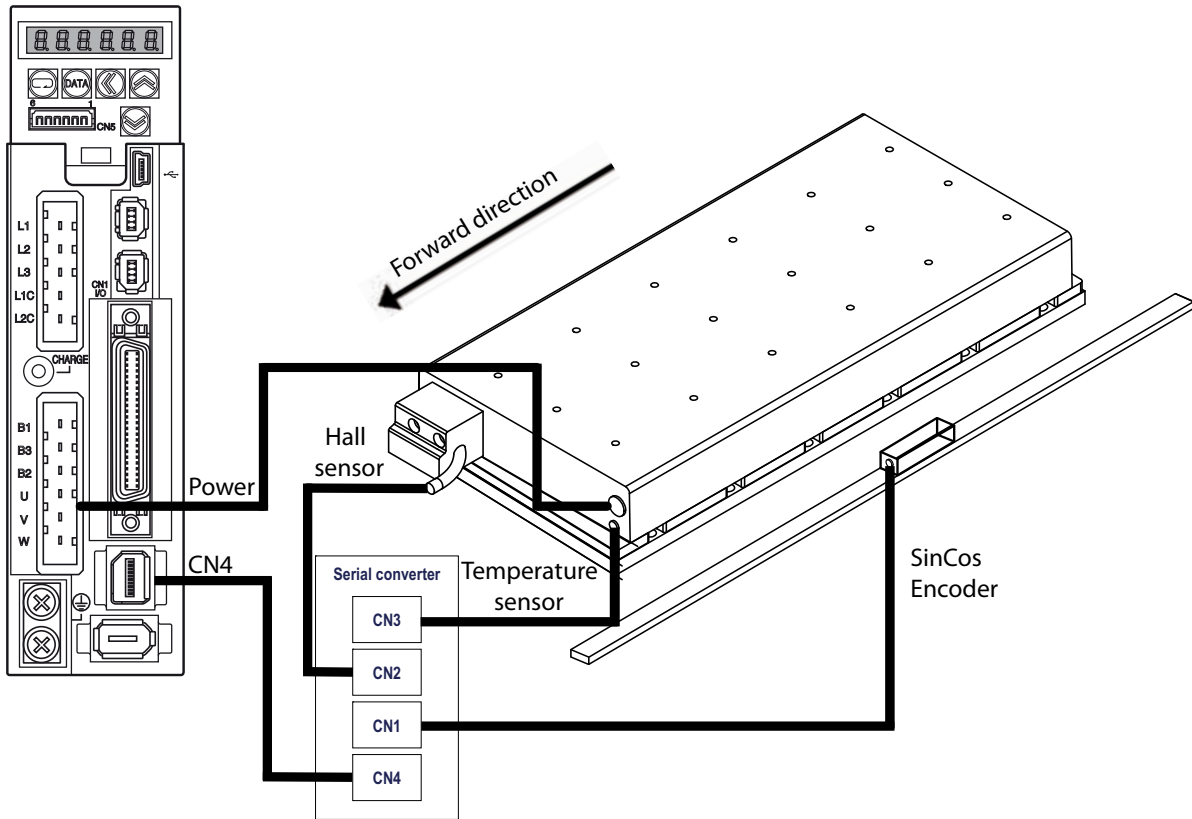

3-5 Cable and Connector Specifications

Encoder Cable Specifications

These cables are used to connect the encoder between the Linear Servo Drive and the servomotor.

Select the cable matching the Linear servomotor. The cables listed are flexible, shielded and have IP67 protection.

Encoder Cables

R88A-CRKNxxxCR-E

This cable is used to:

-Connect to the servodrive an A/B encoder with the pinout of Numerik Jena encoder pinout (Sub-D 15 pin connector type) or equivalent.

-Connect the Serial Converter unit serial protocol output (CN4) to the servodrive encoder input.

Model	Length (L)
R88A-CRKN001-5CR-E	1.5 m
R88A-CRKN003CR-E	3 m
R88A-CRKN005CR-E	5 m
R88A-CRKN010CR-E	10 m
R88A-CRKN015CR-E	15 m
R88A-CRKN020CR-E	20 m

Connection configuration and external dimensions

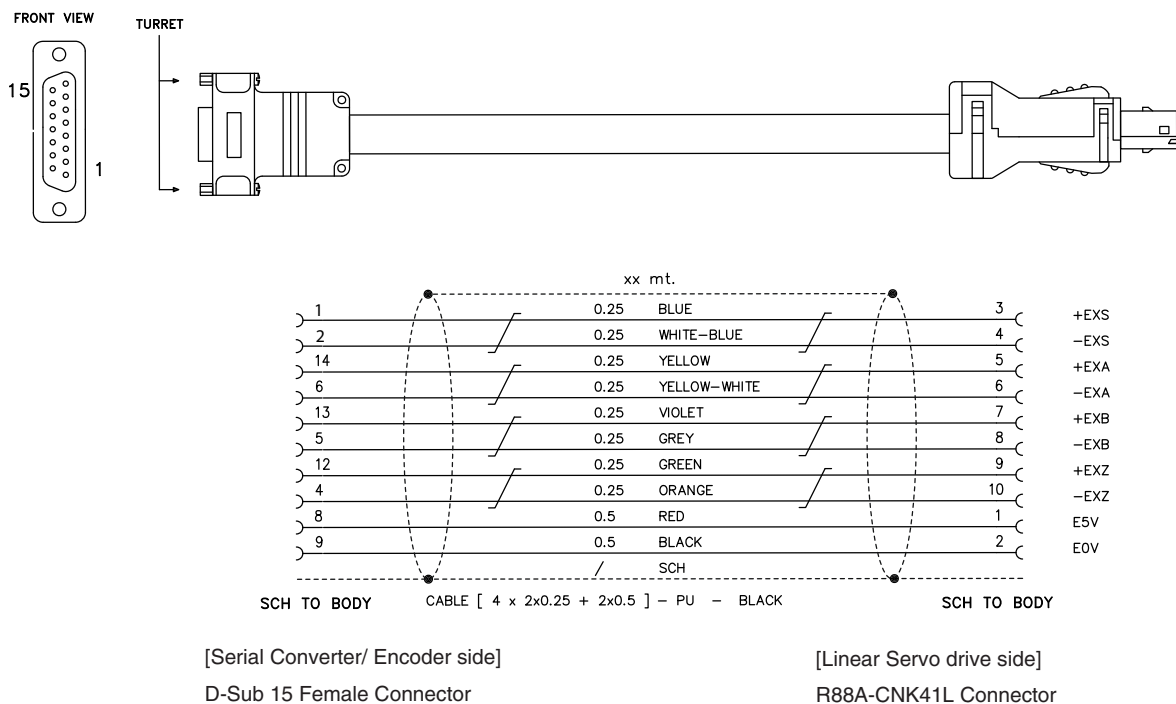

3-5 Cable and Connector Specifications

R88A-CFKAxxxCR-E

Extension feedback cable from Serial Converter (CN1) to SinCos Encoder with Numerik Jena encoder pinout (Sub-D 15 pin connector type) or equivalent.

Model	Length (L)
R88A-CFKA001-5CR-E	1.5 m
R88A-CFKA003CR-E	3 m
R88A-CFKA005CR-E	5 m
R88A-CFKA010CR-E	10 m
R88A-CFKA015CR-E	15 m

Connection configuration and external dimensions

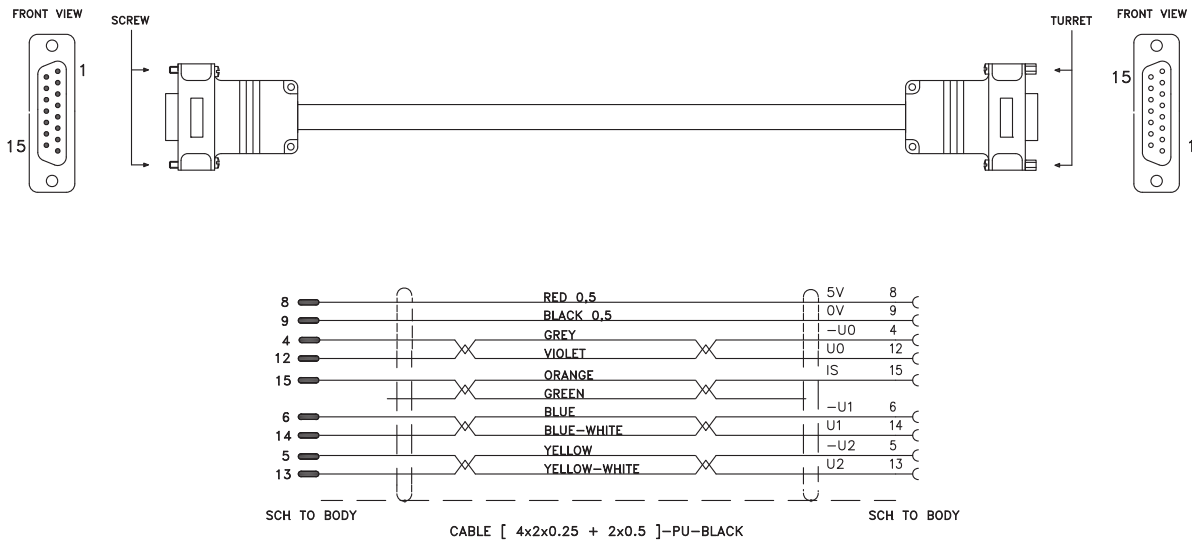

[Serial Converter side]
D-Sub 15 Male Connector

[Encoder side]
D-Sub 15 Female Connector

R88A-CFKBxxxCR-E

Extension cable from Serial Converter to Hall sensor and Temperature connectors in the linear motor.

This motor is either use for:

- Connect the Temperature sensors from the linear motor to CN3 (or CN2) connector in the Serial Converter.
- Connect the Hall sensor signal from the Hall sensor unit attached to the motor to the CN2 connector in the Serial Converter.

Model	Length (L)
R88A-CFKB001-5CR-E	1.5 m
R88A-CFKB003CR-E	3 m
R88A-CFKB005CR-E	5 m
R88A-CFKB010CR-E	10 m
R88A-CFKB015CR-E	15 m

Connection configuration and external dimensions

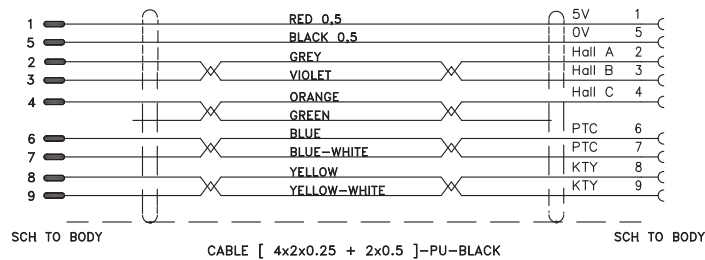
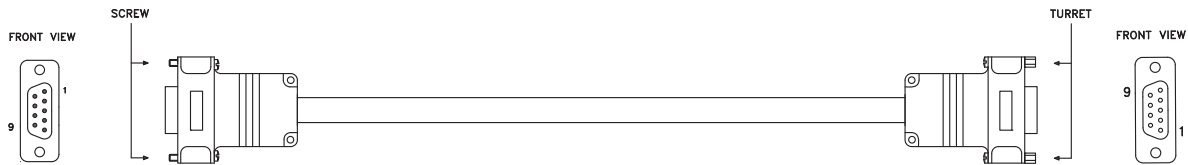

[Serial Converter side]

D-Sub 9 Male Connector

[Hall/ Temperature motor side]

D-Sub 9 Female Connector

Note: It is possible to connect both, hall sensor and temperature to Serial Converter (CN2) at the same time using a single cable but, then, it is necessary to prepare a cable adaptor by the user in the motor side.

Diagram with connections

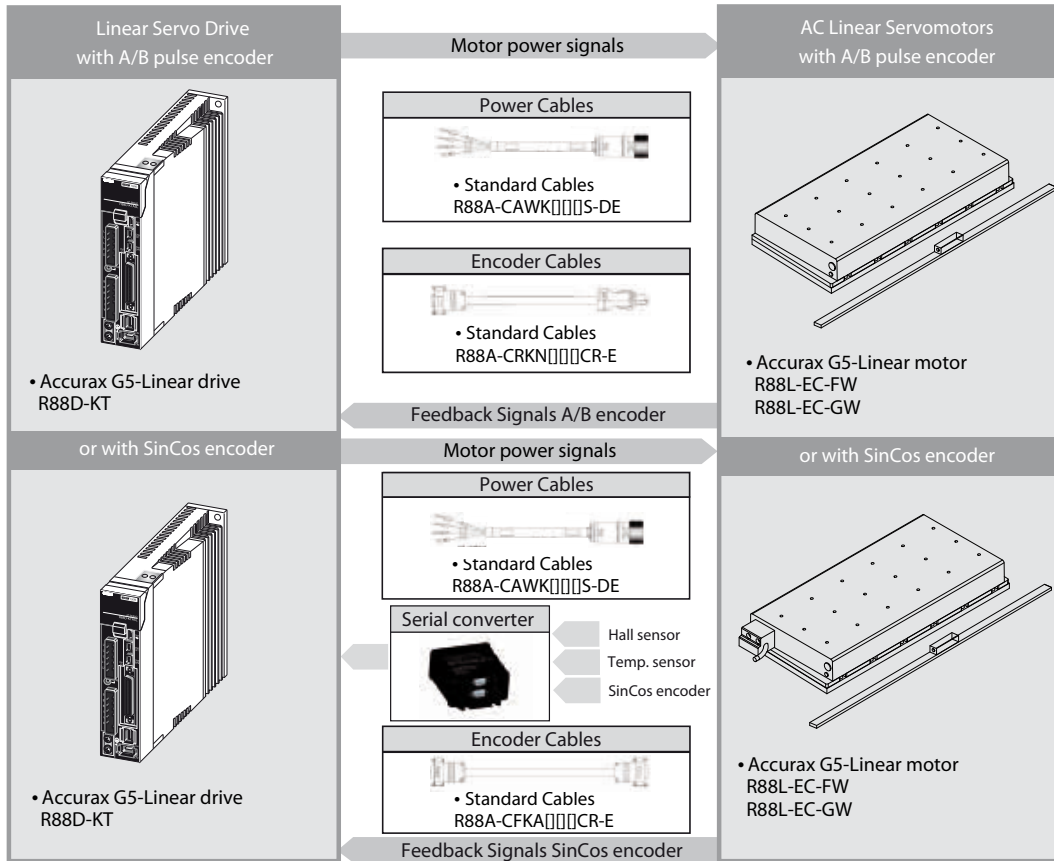

3

Specifications

Motor Power Cable Specifications

These cables connect the Linear Servo Drive and the servomotor. Select the cable matching the Linear servomotor.

The cables listed are flexible, shielded and have IP67 protection.

Power Cables

R88A-CAWKxxxS-DE

Motor Power Cables for Iron-core linear motors with connectors.

Model	Length (L)
R88A-CAWK001-5S-DE	1.5 m
R88A-CAWK003S-DE	3 m
R88A-CAWK005S-DE	5 m
R88A-CAWK010S-DE	10 m
R88A-CAWK015S-DE	15 m
R88A-CAWK020S-DE	20 m

Connection configuration and external dimensions

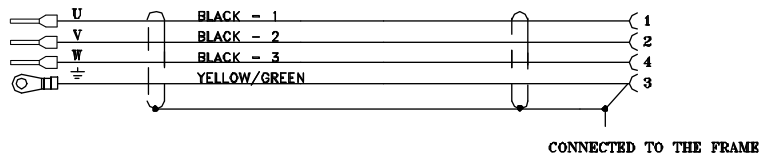
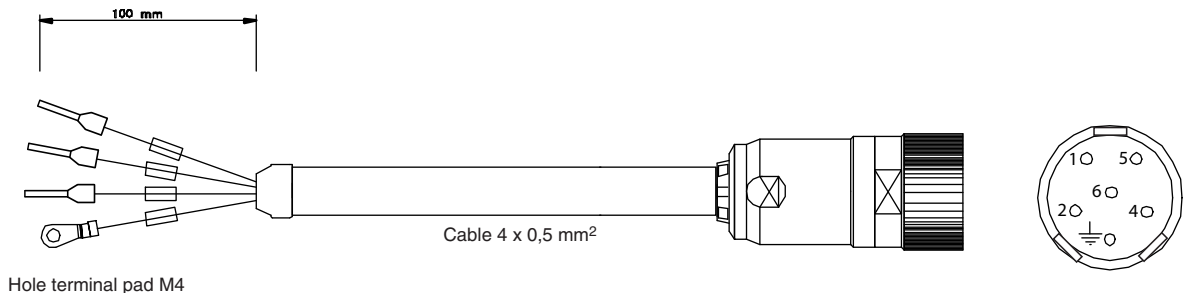

3-5 Cable and Connector Specifications

R88A-CAWBxxxS-DE

Motor Power Cables for Ironless linear motors with connectors.

Model	Length (L)
R88A-CAWB001-5S-DE	1.5 m
R88A-CAWB003S-DE	3 m
R88A-CAWB005S-DE	5 m
R88A-CAWB010S-DE	10 m
R88A-CAWB015S-DE	15 m
R88A-CAWB020S-DE	20 m

Connection configuration and external dimensions

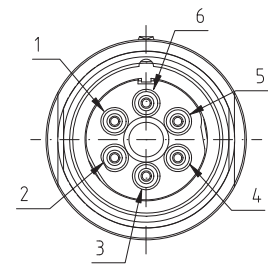
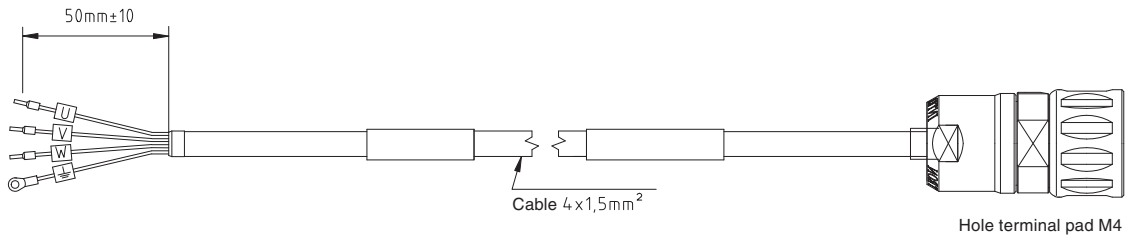

Connector model:
SPOC06KFSDN169

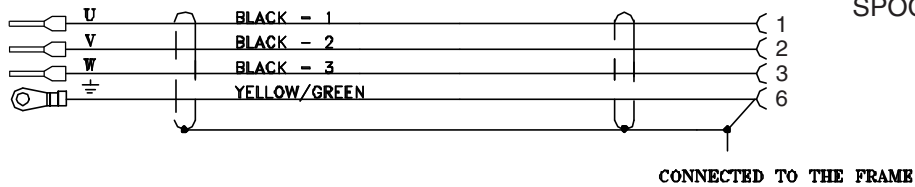

3

Specifications

Cable for Safety Functions (for CN8)

Cable for Safety Functions

R88A-CSK003S-E

Safety connector with 3m cable (with loose wires at one end).

Model	Length (L)
R88A-CSK003S-E	3 m

Connection configuration and external dimensions

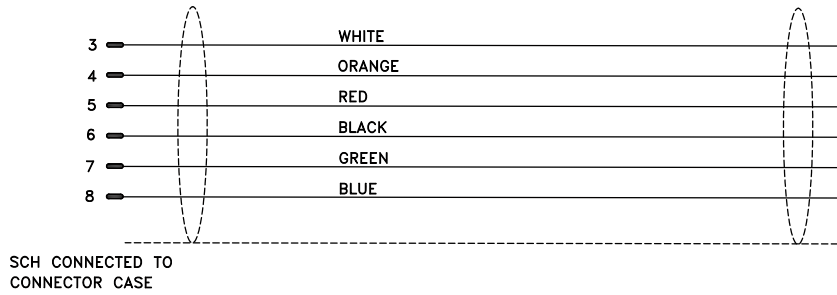
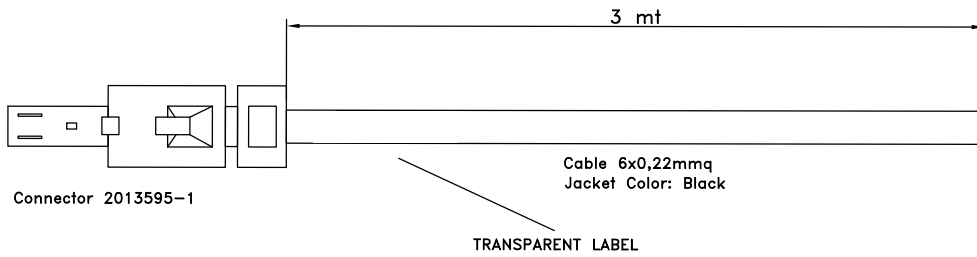

Connector Specifications

Control I/O Connector (R88A-CNU11C)

This is the connector to be connected to the drive's control I/O connector (CN1).
Use this connector when preparing a control cable by yourself.

Dimensions

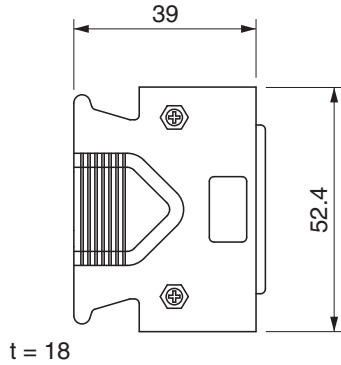

Connector plug model
10150-3000PE (Sumitomo 3M)
Connector case model
10350-52A0-008 (Sumitomo 3M)

Encoder Connector (R88A-CNK41L)

Linear Servo Drive external encoder connector (CN4).

Dimensions

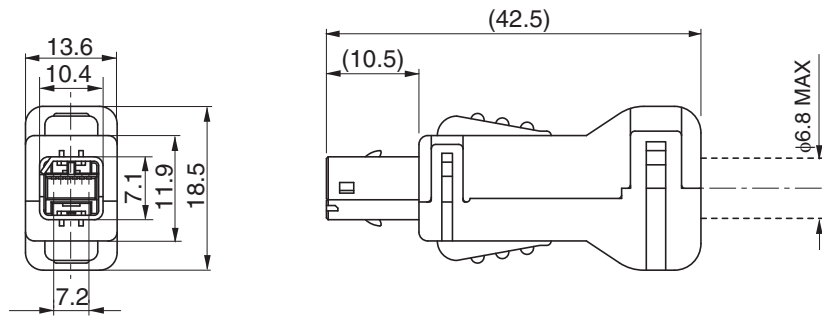

Connector plug model MUF-PK10K-X (J.S.T. Mfg. Co.,Ltd)

Analog Monitor Cable Specifications

Analog Monitor Cable (R88A-CMK001S)

Connection configuration and external dimensions

Symbol	No.	
SP	1	Red
IM	2	Black
GND	3	White
	4	
	5	
	6	

Cable: AWG24 × 3C UL1007

Connector housing: 51004-0600 (Molex Japan)
 Connector terminal: 50011-8100 (Molex Japan)

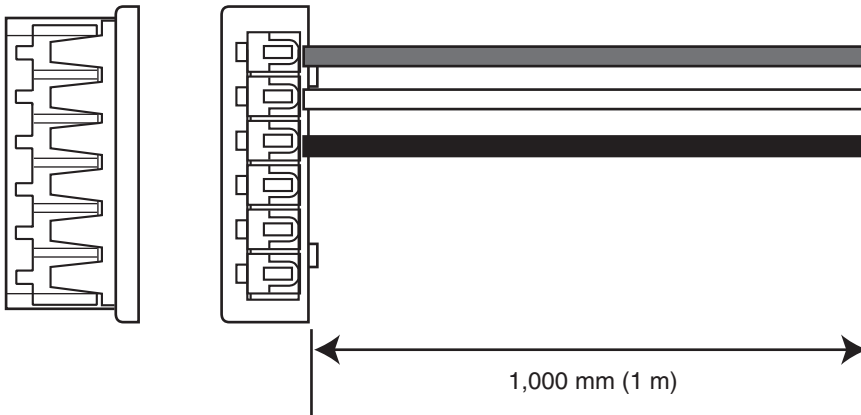

Control Cable Specifications

Specified Cables for Motion Control Unit (R88A-CPGxMx)

Use this cable to connect to the Motion Control Units for OMRON Programmable Controllers (SYSMAC). Cables are available for either 1 axis or 2 axes. The following Motion Control Units can be used. CS1W-MC221/421(-V1)

Cable types

- ◆ Cables for 1 axis

Model	Length (L)	Outer diameter of sheath	Weight
R88A-CPG001M1	1 m	8.3 dia.	Approx. 0.2 kg
R88A-CPG002M1	2 m		Approx. 0.3 kg
R88A-CPG003M1	3 m		Approx. 0.4 kg
R88A-CPG005M1	5 m		Approx. 0.6 kg

- ◆ Cables for 2 axes

Model	Length (L)	Outer diameter of sheath	Weight
R88A-CPG001M2	1 m	8.3 dia.	Approx. 0.3 kg
R88A-CPG002M2	2 m		Approx. 0.5 kg
R88A-CPG003M2	3 m		Approx. 0.7 kg
R88A-CPG005M2	5 m		Approx. 1.0 kg

Connection configuration and external dimensions

- ◆ Cables for 1 axis

Motion Control Unit side
CS1W-MC221/421(-V1)

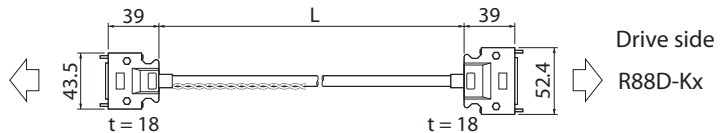

- ◆ Cables for 2 axes

Motion Control Unit side
CS1W-MC221/421(-V1)

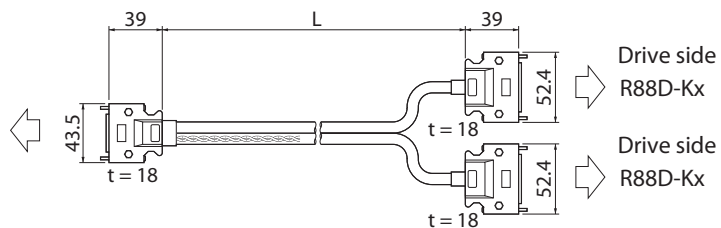

Wiring

- Cables for 1 axis

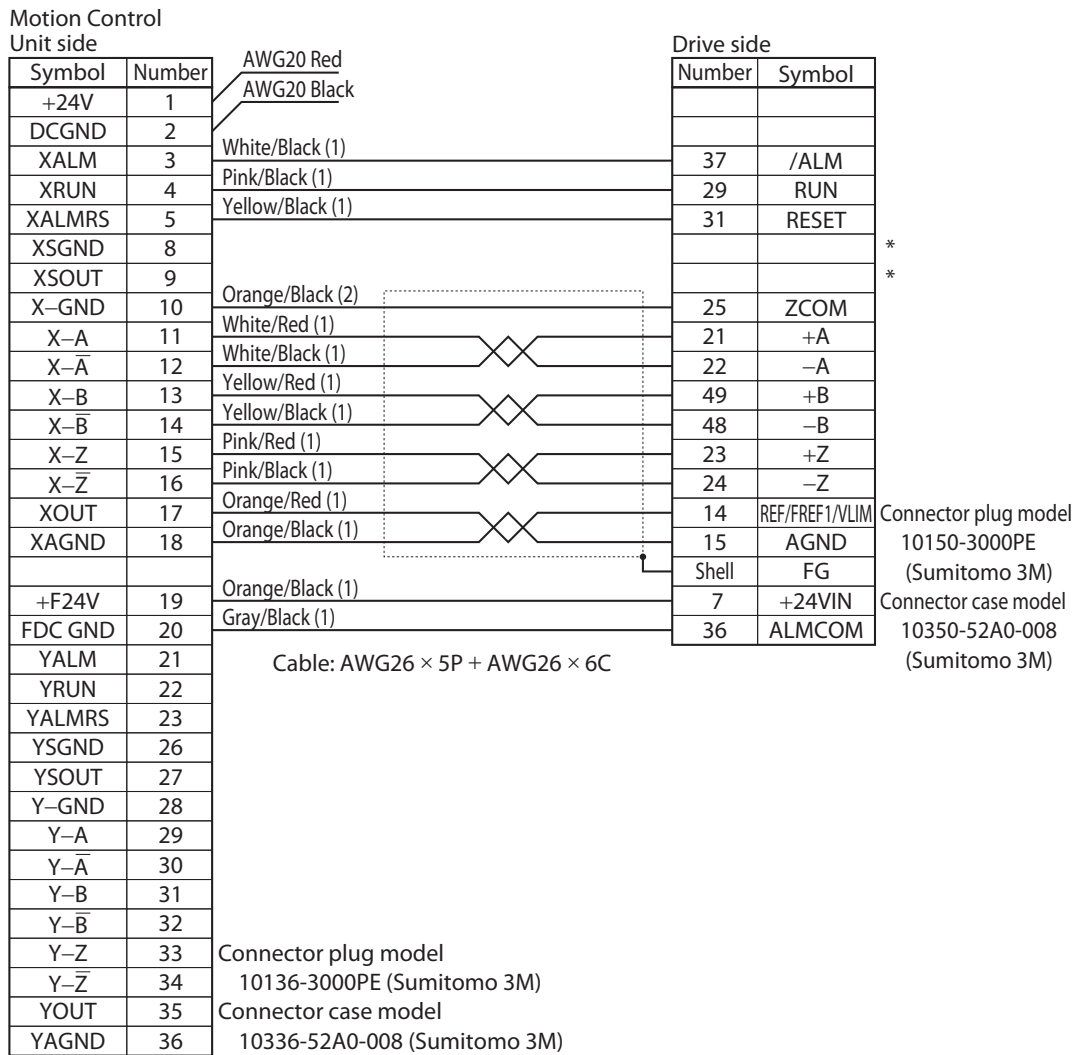

- The symbols on the controller side are the DRVX and DRVY connector symbols. For the DRVZ and DRVU connectors, X and Y are indicated as Z and U, respectively.
- Terminals marked with asterisks are for absolute encoders and have no use with linear motors.
- Connect 24 VDC to the 2 lines (red and black) extending from the connector on the controller side. (red: +24 V, black: -)

3-5 Cable and Connector Specifications

♦ Cables for 2 axes

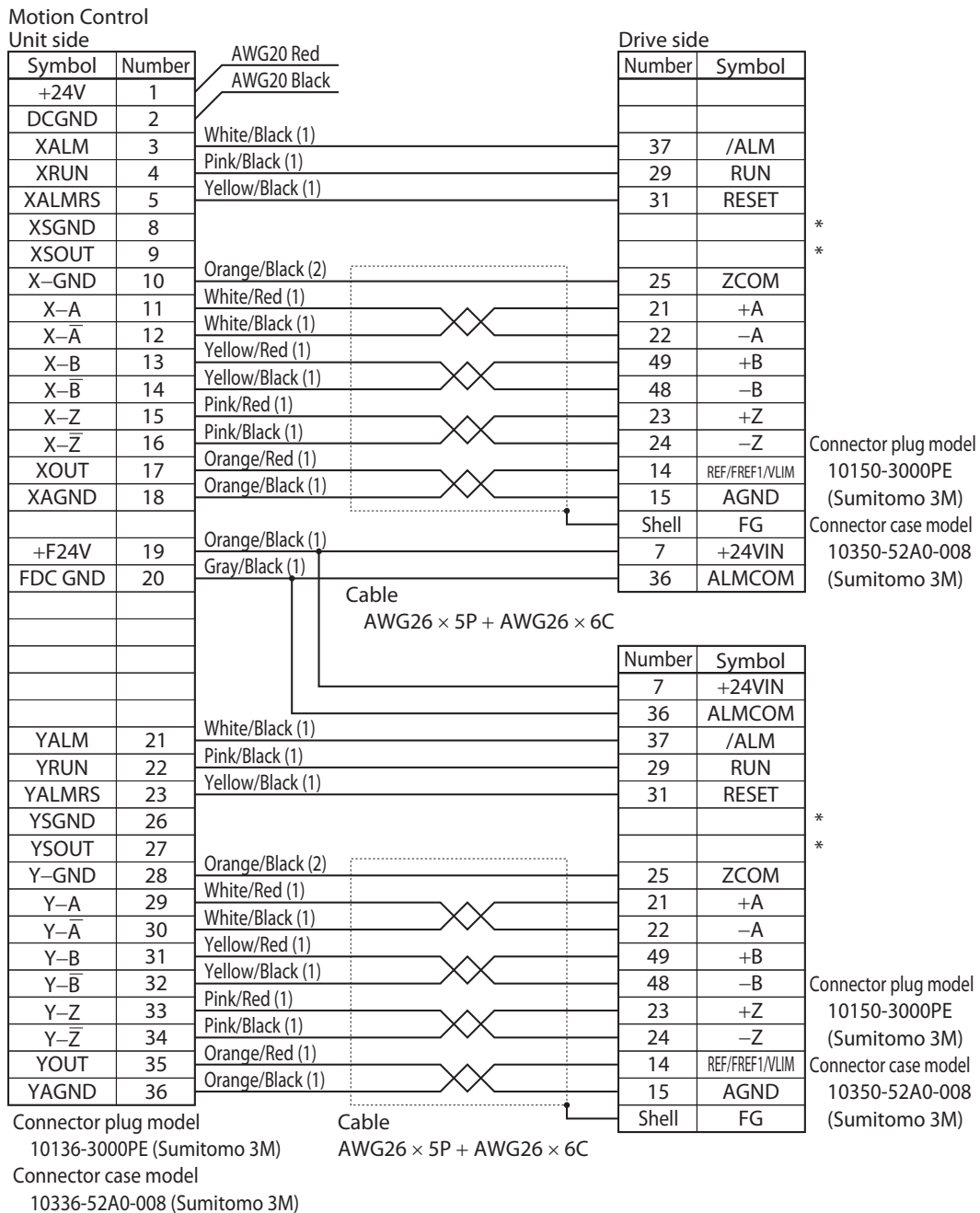

- ♦ The symbols on the controller side are the DRVX and DRVY connector symbols. For the DRVZ and DRVU connectors, X and Y are indicated as Z and U, respectively.
- ♦ Terminals marked with asterisks are for absolute encoders and have no use for linear motors.
- ♦ Connect 24 VDC to the 2 lines (red and black) extending from the connector on the controller side. (red: +24 V, black: -)

Specifications

Specified Cables for Position Control Unit (for CJ1W-NCxx4 - high-speed type -)

This cable is for connecting Position Control Units (CJ1W-NCxx4) for OMRON Programmable Controller SYSMAC CJ Series. Cables are available for either 1 axis or 2 axes. The following types of Position Control Units are supported.
CJ1W-NC214/-NC414/-NC234/-NC434

Cable types

- Cable for line-drive output for 1 axis

Model	Length
XW2Z-100J-G9	1 m
XW2Z-500J-G9	5 m
XW2Z-10MJ-G9	10 m

- Cable for open collector output for 1 axis

Model	Length
XW2Z-100J-G3	1 m
XW2Z-300J-G3	3 m

- Cable for line-drive output for 2 axes

Model	Length
XW2Z-100J-G1	1 m
XW2Z-500J-G1	5 m
XW2Z-10MJ-G1	10 m

- Cable for open collector output for 2 axes

Model	Length
XW2Z-100J-G5	1 m
XW2Z-300J-G5	3 m

Connection configuration and external dimensions

- Cables for 1 axis

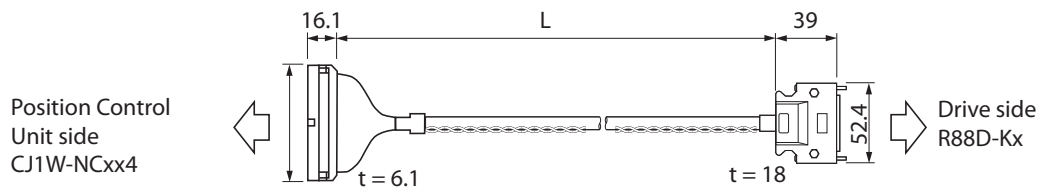

- Cables for 2 axes

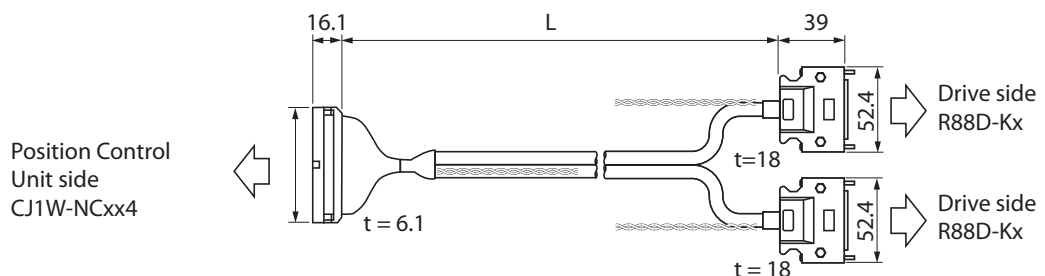

3-5 Cable and Connector Specifications

Wiring

- ◆ Cable for line-drive output for 1 axis

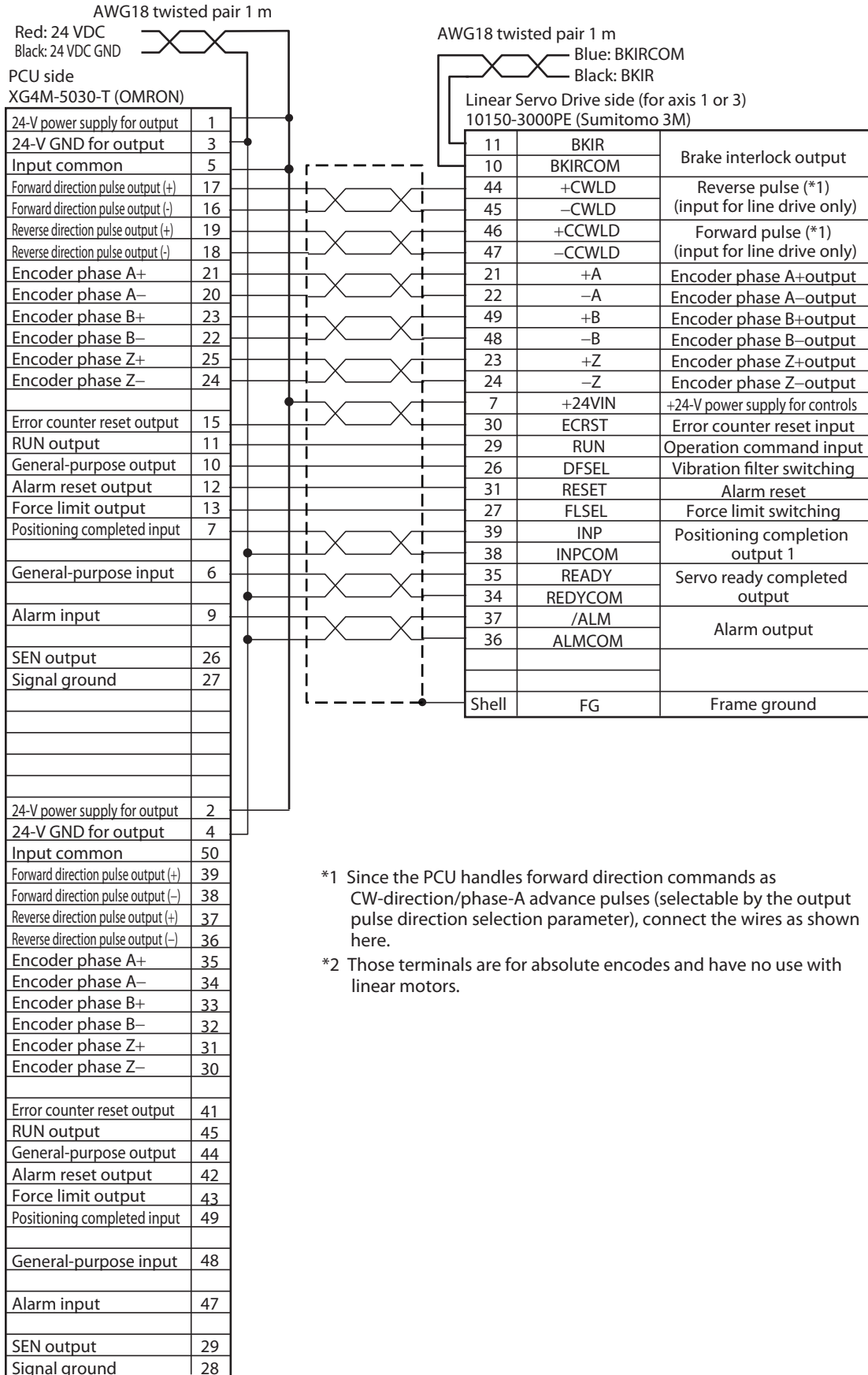

*1 Since the PCU handles forward direction commands as CW-direction/phase-A advance pulses (selectable by the output pulse direction selection parameter), connect the wires as shown here.

*2 Those terminals are for absolute encodes and have no use with linear motors.

Specifications

◆ Cable for open collector output for 1 axis

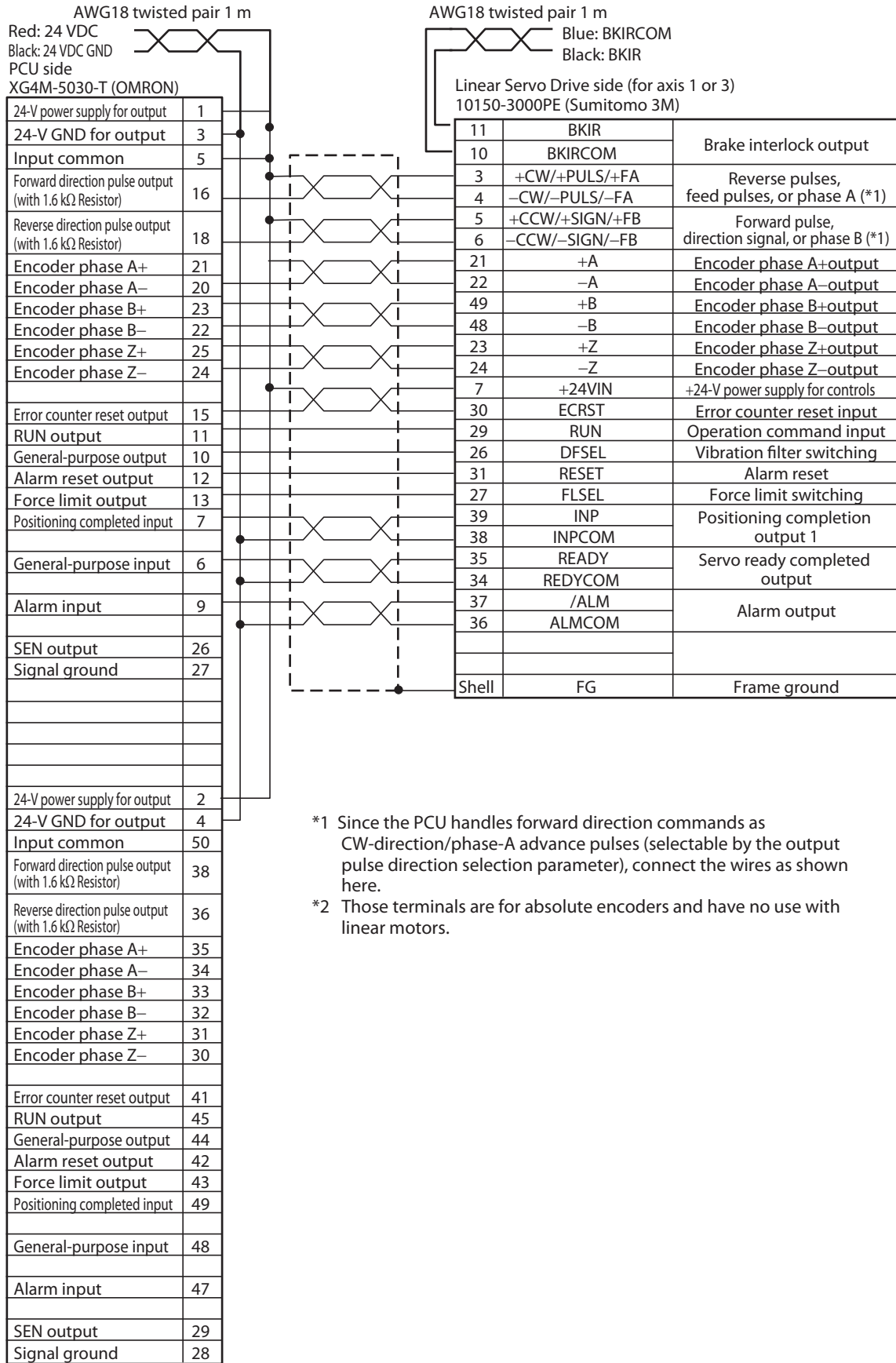

*1 Since the PCU handles forward direction commands as CW-direction/phase-A advance pulses (selectable by the output pulse direction selection parameter), connect the wires as shown here.

*2 Those terminals are for absolute encoders and have no use with linear motors.

3-5 Cable and Connector Specifications

◆ Cable for line-drive output for 2 axes

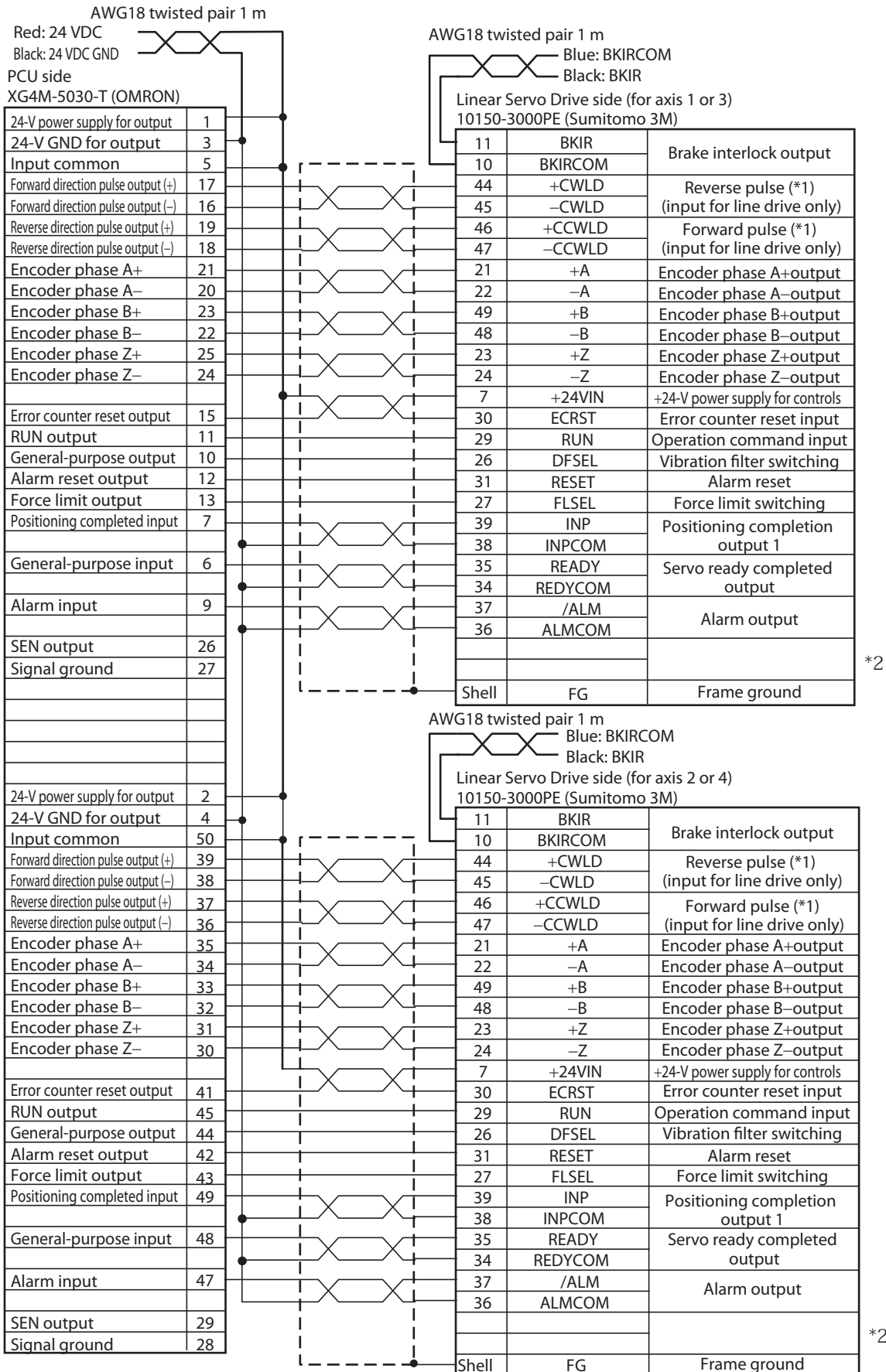

*1 Since the PCU handles forward direction commands as CW-direction/phase-A advance pulses (selectable by the output pulse direction selection parameter), connect the wires as shown here.

*2 Those terminals are for absolute encoders and have no use with linear motors.

◆ Cable for open collector output for 2 axes

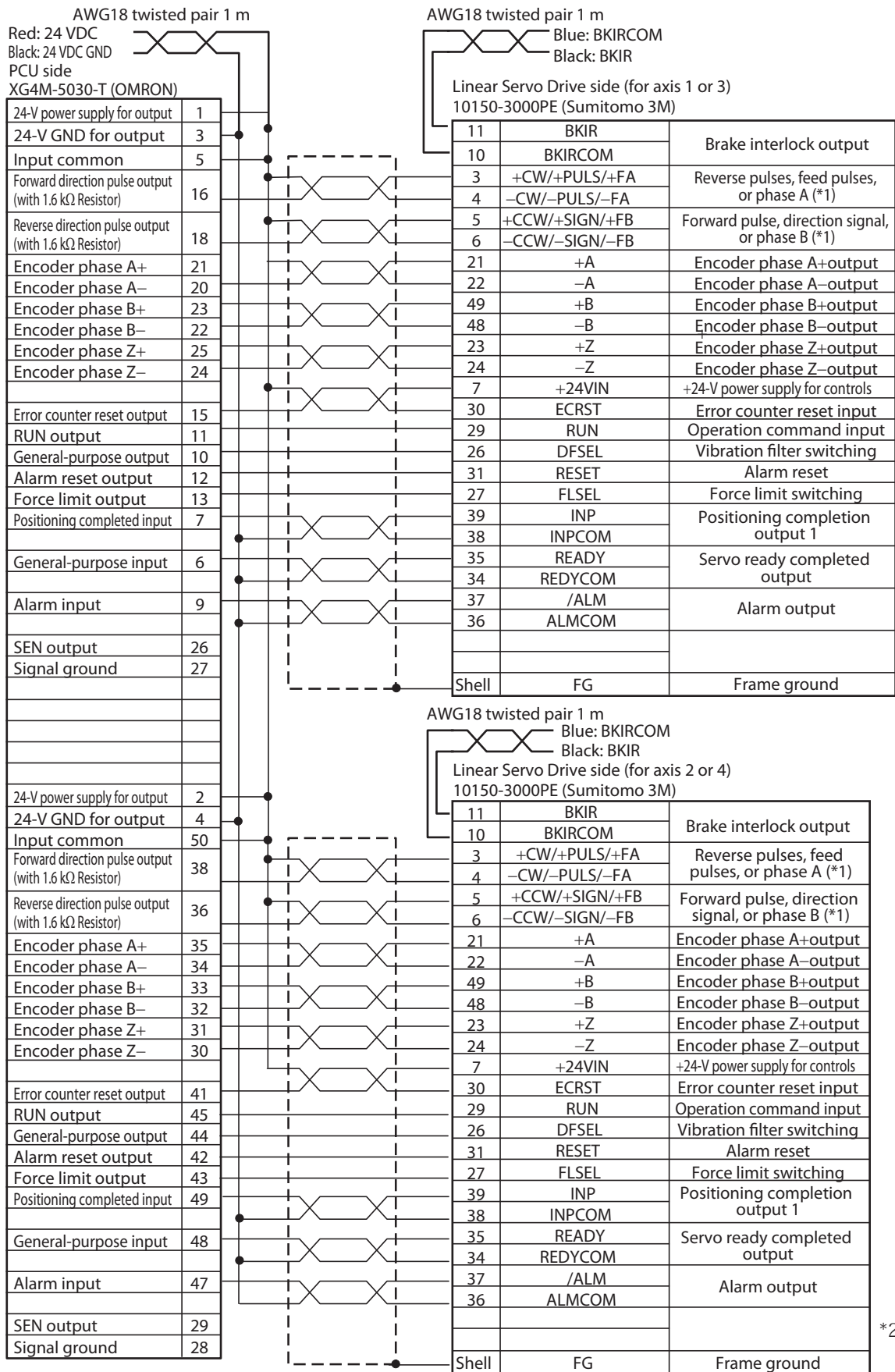

*1 Since the PCU handles forward direction commands as CW-direction/phase-A advance pulses (selectable by the output pulse direction selection parameter), connect the wires as shown here.

3-5 Cable and Connector Specifications

*2 Those terminals are for absolute encoders and have no use with linear motors.

General-purpose Control Cables (R88A-CPGxS)

This is a cable to connect the Linear Servo drive I/O signals (CN1 connector) to a general purpose controller. All Linear servo drive I/O signals are wired. The connector for the controller is not provided.

Cable types

Model	Length (L)	Outer diameter of sheath	Weight
R88A-CPG001S	1 m	12.8 dia.	Approx. 0.3 kg
R88A-CPG002S	2 m		Approx. 0.6 kg

Connection configuration and external dimensions

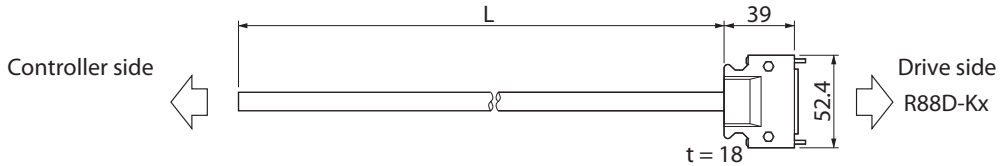

3-5 Cable and Connector Specifications

Wiring

Number	Wire/Mark color	Symbol
1	Orange/Red (1)	+24VCW
2	Orange/Black (1)	+24VCCW
3	Gray/Red (1)	CW+
4	Gray/Black (1)	CW-
5	White/Red (1)	CCW+
6	White/Black (1)	CCW-
7	Yellow/Red (1)	COM+
8	Pink/Red (1)	SI1
9	Pink/Black (1)	SI2
10	Orange/Red (2)	SO1-
11	Orange/Black (2)	SO1+
12	Yellow/Black (1)	SO5+
13	Gray/Black (2)	GND
14	White/Red (2)	AI1
15	White/Black (2)	GND
16	Yellow/Red (2)	AI2
17	Yellow/Black (2), Pink/Black (2)	GND
18	Pink/Red (2)	AI3
19	Orange/Red (5)	CZ
20	Gray/Red (2)	Not used
21	Orange/Red (3)	OA+
22	Orange/Black (3)	OA-
23	Gray/Red (3)	OZ+
24	Gray/Black (3)	OZ-
25	Orange/Black (5)	GND
26	White/Red (3)	SI3

Number	Wire/Mark color	Symbol
27	Pink/Black (3)	SI4
28	White/Black (3)	SI5
29	Yellow/Red (3)	SI6
30	Pink/Red (3)	SI7
31	Yellow/Black (3)	SI8
32	Gray/Black (4)	SI9
33	Orange/Red (4)	SI10
34	White/Red (4)	S02-
35	White/Black (4)	S02+
36	Yellow/Red (4)	ALM-
37	Yellow/Black (4)	ALM+
38	Pink/Red (4)	S04-
39	Pink/Black (4)	S04+
40	Gray/Red (4)	S06+
41	Orange/Black (4)	S05- & S06-
42	Gray/Red (5)	Not used
43	Gray/Black (5)	Not used
44	White/Red (5)	CWLD+
45	White/Black (5)	CWLD-
46	Yellow/Red (5)	CCWLD+
47	Yellow/Black (5)	CCWLD-
48	Pink/Black (5)	OB-
49	Pink/Red (5)	OB+
50	---	FG
Shell	---	FG

Connector plug model: 10150-3000PE (Sumitomo 3M)
 Connector case model: 10350-52A0-008 (Sumitomo 3M)
 Cable: AWG24 × 25P UL20276

- Wires with the same wire color and the same number of marks form a twisted pair.
 Example: Wires with respective wire and mark colors of orange/red (1) and orange/black (1) form a twisted pair.

Terminal Block Cables (XW2Z-xJ-B24)

This is a cable to connect the Linear Servo drive I/O signals (CN1 connector) to a terminal block for general-purpose. All Linear servo drive I/O signals are wired.

Cable types

Model	Length (L)	Outer diameter of sheath	Weight
XW2Z-100J-B24	1 m	11.2 dia.	Approx. 0.2 kg
XW2Z-200J-B24	2 m		Approx. 0.4 kg

Connection configuration and external dimensions

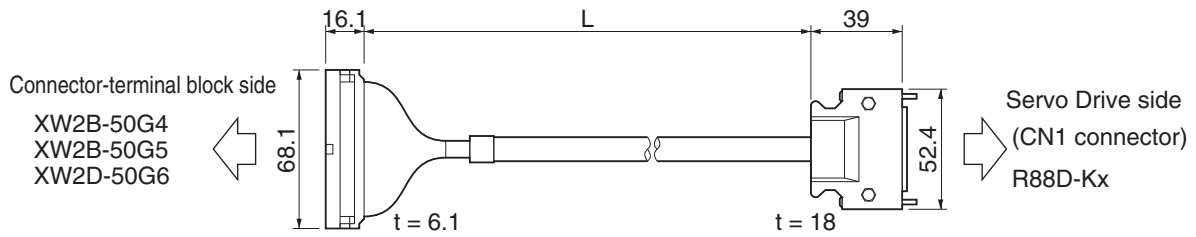

3-5 Cable and Connector Specifications

Terminal block		Connector	Drive side		
Number	Number		Number	Wire and mark color	Symbol
1	1		1	Blue/Red (1)	+24VCW
2	2		2	Blue/Black (1)	+24VCCW
3	3		3	Pink/Red (1)	CW+
4	4		4	Pink/Black (1)	CW-
5	5		5	Green/Red (1)	CCW+
6	6		6	Green/Black (1)	CCW-
7	7		7	Orange/Red (1)	COM+
8	8		8	Gray/Red (1)	SI1
9	9		9	Gray/Black (1)	SI2
10	10		10	Blue/Red (2)	SO1-
11	11		11	Blue/Black (2)	SO1+
13	13		13	Pink/Red (2)	GND
20	20		20	Pink/Black (2)	Not used
14	14		14	Green/Red (2)	AI1
15	15		15	Green/Black (2)	GND
16	16		16	Orange/Red(2)	AI2
17	17		17	Orange/Black (2)	GND
18	18		18	Gray/Red (1)	AI3
12	12		12	Gray/Black(2)	SO5+
19	19		19	Blue/Red (3)	CZ
25	25		25	Blue/Black (3)	GND
21	21		21	Pink/Red (3)	OA+
22	22		22	Pink/Black(3)	OA-
23	23		23	Green/Red (3)	OZ+
24	24		24	Green/Black (3)	OZ-
26	26		26	Orange/Red(3)	SI3
27	27		27	Orange/Black(3)	SI4
28	28		28	Gray/Red (3)	SI5
29	29		29	Gray/Black(3)	SI6
30	30		30	Blue/Red (4)	SI7
31	31		31	Blue/Black (4)	SI8
32	32		32	Pink/Red (4)	SI9
33	33		33	Pink/Black (4)	SI10
34	34		34	Green/Red (4)	SO2-
35	35		35	Green/Black (4)	SO2+
36	36		36	Orange/Red(4)	ALM-
37	37		37	Orange/Black (4)	ALM+
38	38		38	Gray/Red(4)	SO4-
39	39		39	Gray/Black(4)	SO4+
40	40		40	Blue/Red (5)	SO6+
41	41		41	Blue/Black (5)	SO5- & SO6-
42	42		42	Pink/Red (5)	Not used
43	43		43	Pink/Black (5)	Not used
44	44		44	Green/Red (5)	CWLD+
45	45		45	Green/Black (5)	CWLD-
46	46		46	Orange/Red (5)	CCWLD+
47	47		47	Orange/Black (5)	CCWLD-
48	48		48	Gray/Red (5)	OB-
49	49		49	Gray/Black(5)	OB+
50	50		50	Orange/Red(1)	FG
			Shell		FG

• 1 Wires with the same wire color and the same number of marks form a twisted pair
 Example: Wires with respective wire and mark colors of Yellow/Black (1) and Pink/Black (1) form a twisted pair

Drive side connector:
 Connector plug model
 10150-3000PE (Sumitomo 3M)
 Connector case model
 10350-52A0-008 (Sumitomo 3M)
 Connector-terminal Block Connector:
 Connector socket model
 XG4M-5030 (OMRON)
 Strain relief model XG4T-5004 (OMRON)
 Cable: AWG28 × 25P UL2464



Specifications

Terminal Block Unit

The Terminal Block Unit connects the Linear servo drive I/O signals (CN1 connector) for general purpose. Use the cable (XW2Z-xJ-B24) to connect the Terminal Block Unit to the CN1 connector.

XW2B-50G4 (M3 Screw Terminal Block)

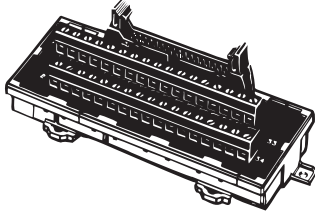

◆ Dimensions

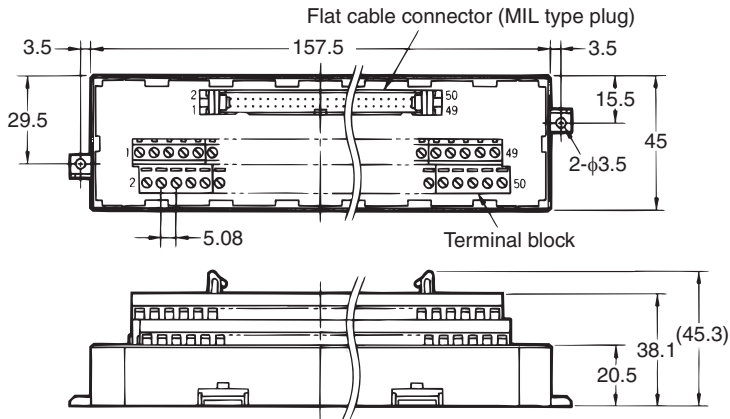

- ◆ Use 0.3 to 1.25 mm² wire (AWG22 to 16).
- ◆ The wire inlet is 1.8 mm (height) × 2.5 mm (width).
- ◆ Strip the insulation from the end of the wire for 6 mm as shown below.

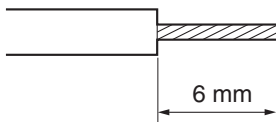

XW2B-50G5 (M3.5 Screw Terminal Block)

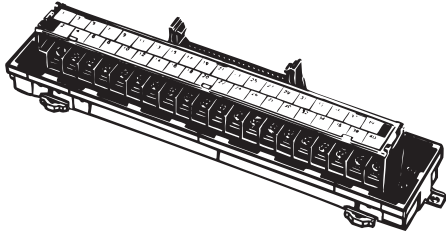

◆ Dimensions

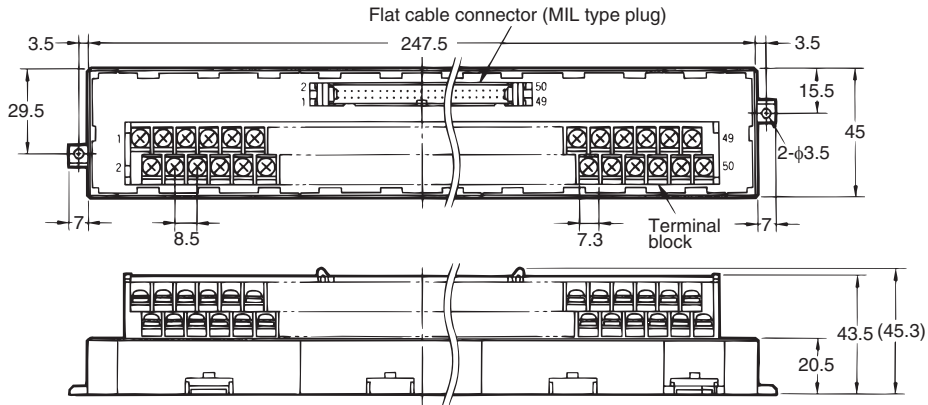

- ◆ When using crimp terminals, use crimp terminals with the following dimensions.
- ◆ When connecting wires and crimp terminals to a terminal block, tighten them with a tightening force of 0.59 N•m.

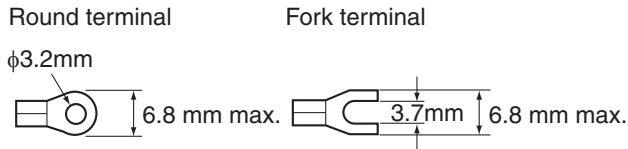

Applicable crimp terminals		Applicable wires
Round terminals	1.25-3	AWG22-16 (0.3 to 1.25 mm ²)
	2-3.5	AWG16-14 (1.25 to 2.0 mm ²)
Fork terminals	1.25Y-3	AWG22-16 (0.3 to 1.25 mm ²)
	2-3.5	AWG16-14 (1.25 to 2.0 mm ²)

XW2D-50G6 (M3 Screw Terminal Block)

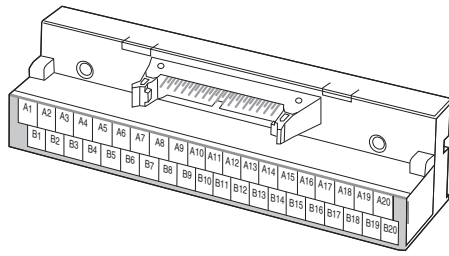

◆ Dimensions

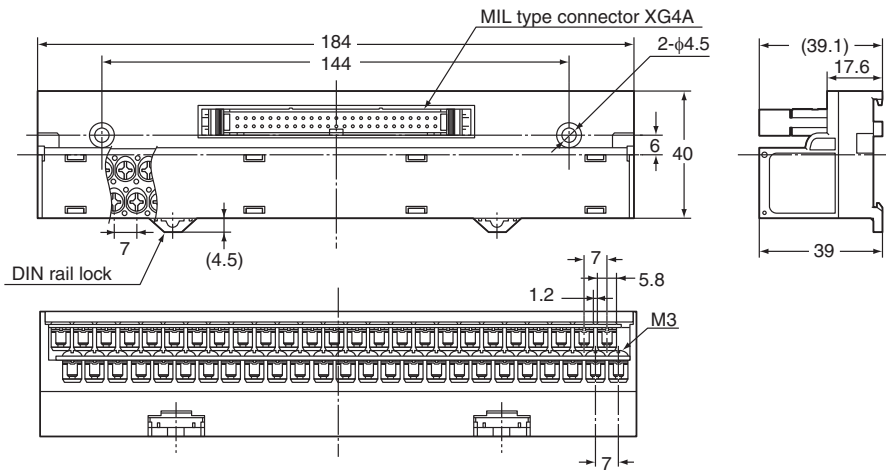

- ◆ When using crimp terminals, use crimp terminals with the following dimensions.
- ◆ When connecting wires and crimp terminals to a terminal block, tighten them with a tightening force of 0.7 N•m.

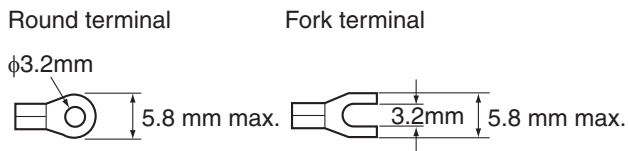

Applicable crimp terminals		Applicable wires
Round terminals	1.25-3	AWG22-16 (0.3 to 1.25 mm ²)
Fork terminals	1.25Y-3	AWG22-16 (0.3 to 1.25 mm ²)

3-6 Servo Relay Units and Cable Specifications

This section provides the specifications for the Servo Relay Unit and cables used for connecting to Position Control Units for OMRON Programmable Controllers (SYSMAC). Select the models that match the Position Control Unit to be used.

Servo Relay Units Specifications

XW2B-20J6-1B

This Servo Relay Unit connects to the following OMRON Position Control Units.

- ◆ CJ1W-NC113/-NC133
- ◆ CS1W-NC113/-NC133
- ◆ C200HW-NC113

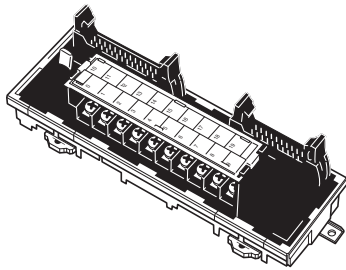

Dimensions

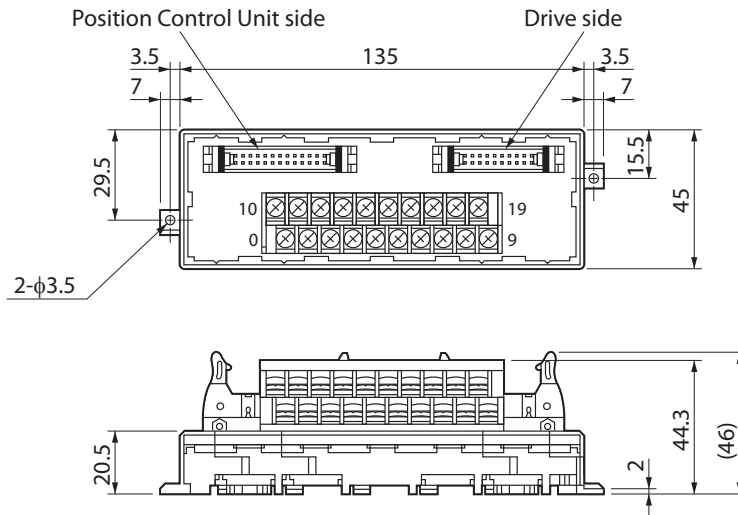

- ◆ Terminal block pitch: 7.62 mm

Wiring

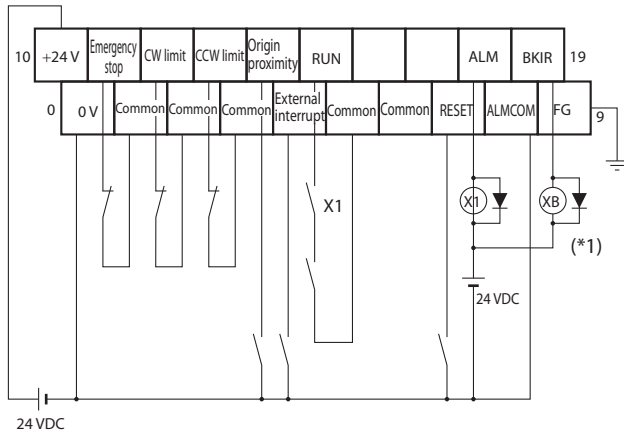

- *1. The XB contacts are used to turn ON/OFF the electromagnetic brake.
- Note 1. Do not connect unused terminals.
- Note 2. The 0 V terminal is internally connected to the common terminals.
- Note 3. The applicable crimp terminal is R1.25-3 (round with open end).

XW2B-40J6-2B

This Servo Relay Unit connects to the following OMRON Position Control Units.

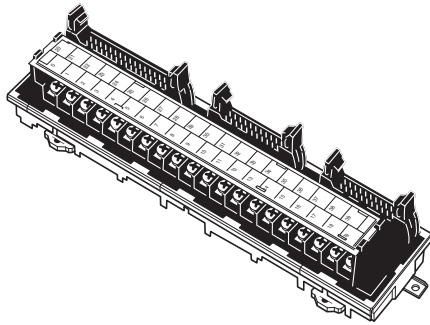

- ◆ CJ1W-NC213/-NC233/-NC413/-NC433
- ◆ CS1W-NC213/-NC233/-NC413/-NC433
- ◆ C200HW-NC213/-NC413

Dimensions

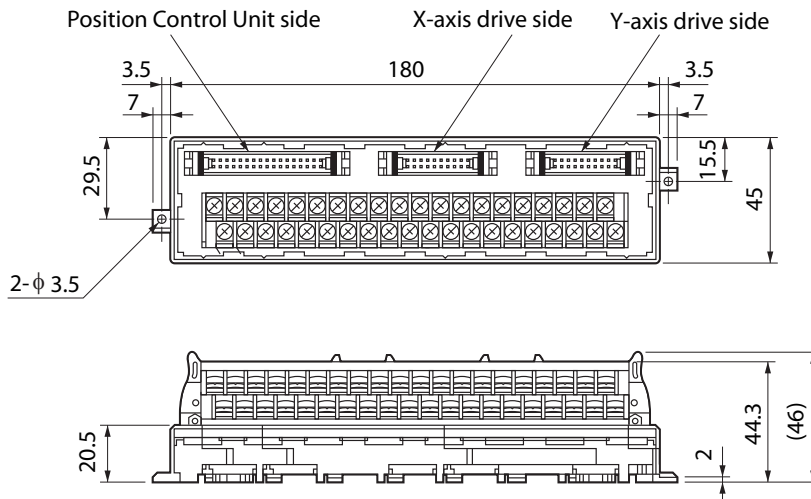

- ◆ Terminal block pitch: 7.62 mm

Wiring

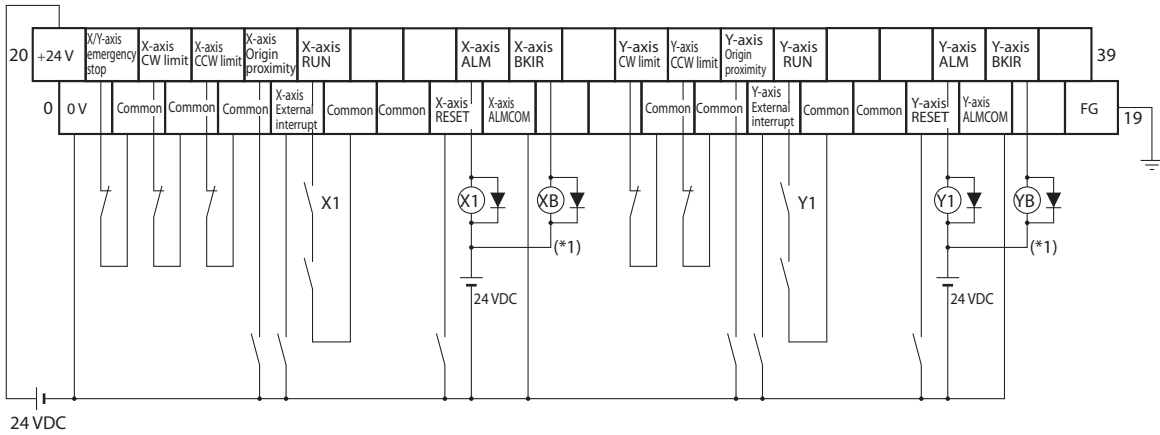

*1. The XB and YB contacts are used to turn ON/OFF the electromagnetic brake.

Note 1. Do not connect unused terminals.

Note 2. The 0 V terminal is internally connected to the common terminals.

Note 3. The applicable crimp terminal is R1.25-3 (round with open end).

XW2B-20J6-3B

This Servo Relay Unit connects to the following OMRON Programmable Controllers.

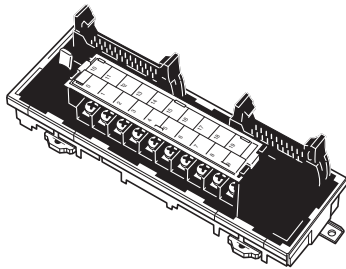

- ◆ CQM1-CPU43-V1
- ◆ CQM1-PLB21

Dimensions

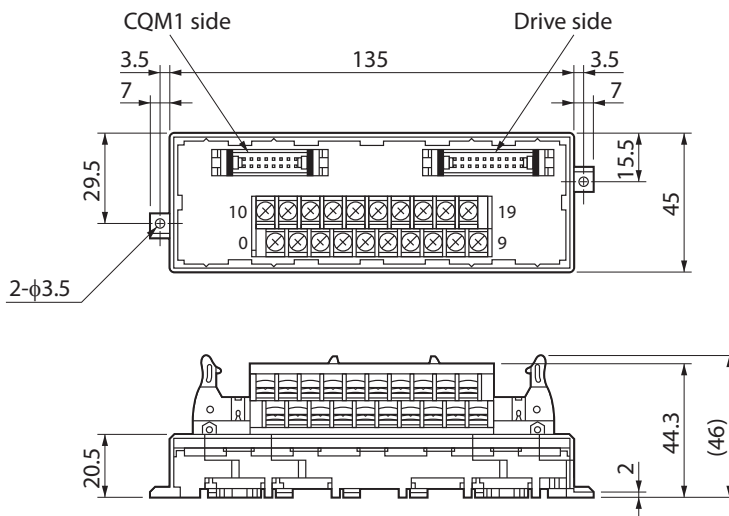

- ◆ Terminal block pitch: 7.62 mm

Wiring

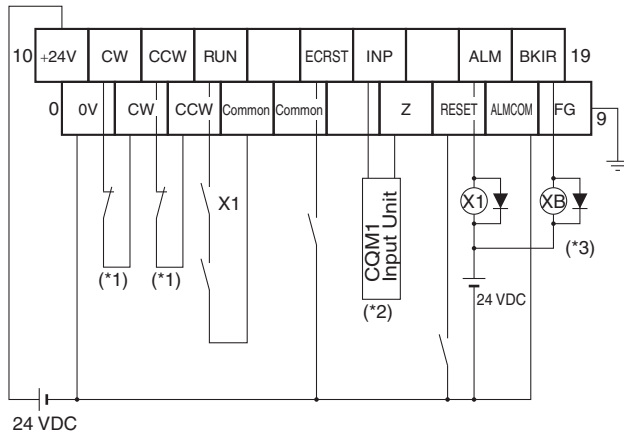

*1. If this signal is input, the output pulse from the CQM1 will be input to the high-speed counter.

*2. Input this output signal to a CQM1 Input Unit.

*3. The XB contacts are used to turn ON/OFF the electromagnetic brake.

Note 1.The phase Z is an open collector.

Note 2.Do not connect unused terminals.

Note 3.The 0 V terminal is internally connected to the common terminals.

Note 4.The applicable crimp terminal is R1.25-3 (round with open end).

3-6 Servo Relay Units and Cable Specifications

XW2B-20J6-8A

This Servo Relay Unit connects to the following OMRON Programmable Controllers.

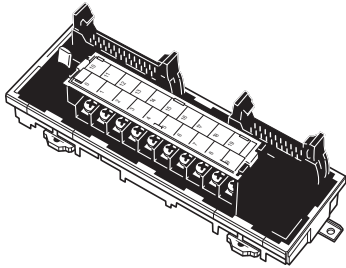

- ♦ CJ1M-CPU21/-CPU22/-CPU23 (for 1 axis)

Dimensions

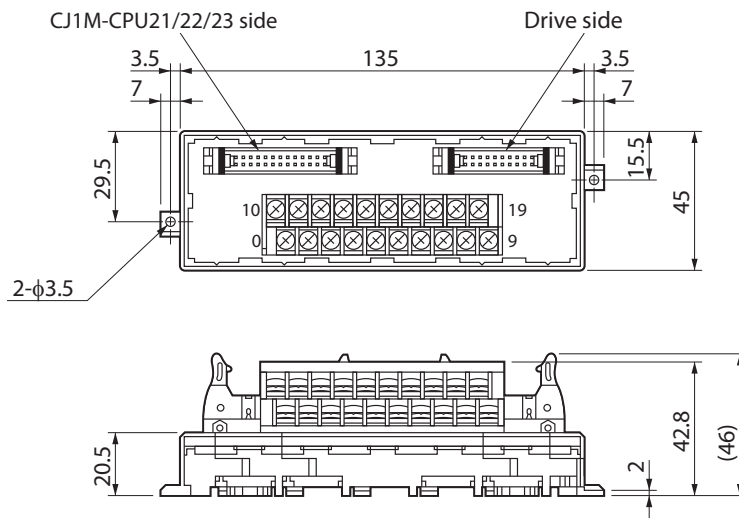

- ♦ Terminal block pitch: 7.62 mm

Wiring

The Linear Servo Drive phase Z output signal is wired to the origin signal in this terminal block.

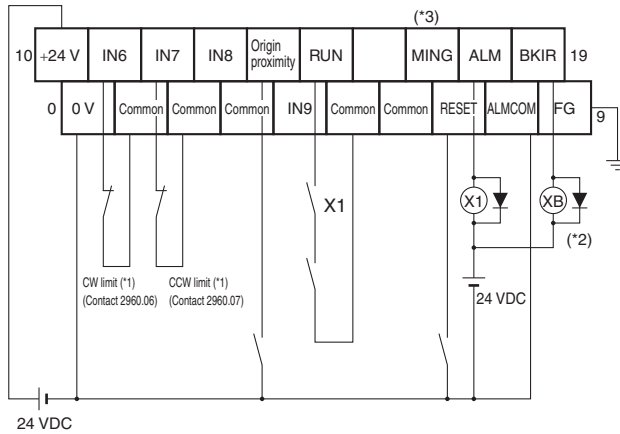

*1. CW and CCW limit input signals can also be input through Input Units. The signal for the CW/CCW limit inputs in the CJ1M are as follows: CW: A540.08, CCW: A540.09 for pulse output 0 and CW: A541.08, CCW: A541.09 for pulse output 1. Accordingly, the actual inputs can be used as the CW/CCW limit by outputting the flags below in the ladder program.

Example)



*2. The XB contacts are used to turn ON/OFF the electromagnetic brake.

*3. Connection to the MING input terminal is disabled.

Note 1. Do not connect unused terminals.

Note 2. The 0 V terminal is internally connected to the common terminals.

Note 3. The applicable crimp terminal is R1.25-3 (round with open end).

3-6 Servo Relay Units and Cable Specifications

XW2B-40J6-9A

This Servo Relay Unit connects to the following OMRON Programmable Controllers.

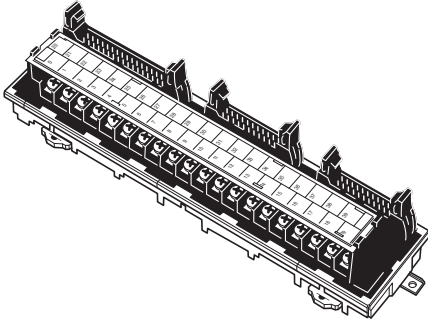

- ◆ CJ1M-CPU21/-CPU22/-CPU23 (for 2 axes)

Dimensions

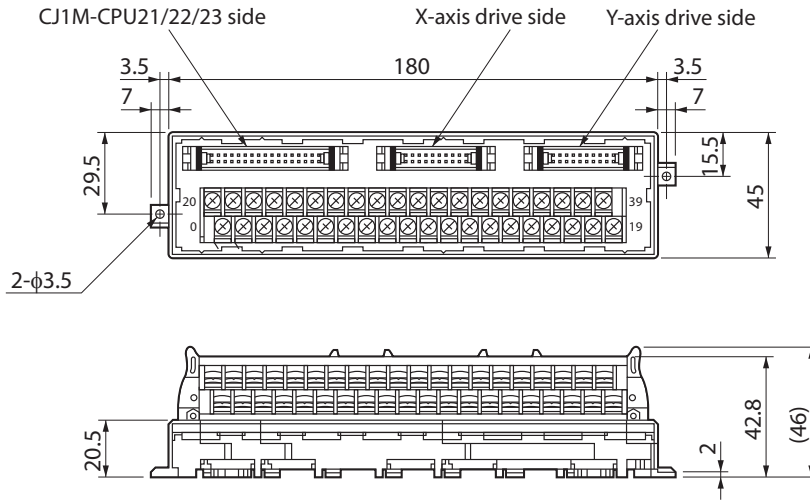

- ◆ Terminal block pitch: 7.62 mm

Wiring

The Linear Servo Drive phase Z output signal is wired to the origin signal in this terminal block.

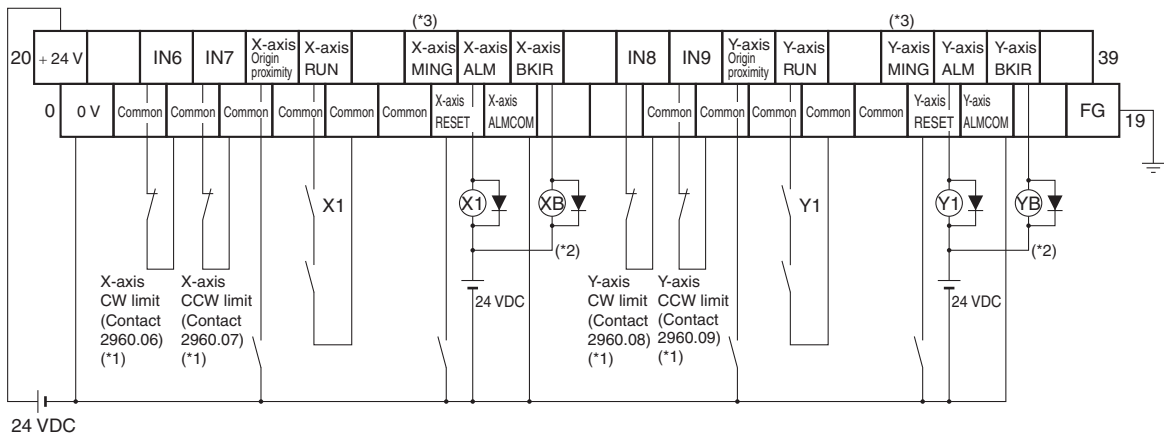

- *1. CW and CCW limit input signals can also be input through Input Units. The signal for the CW/CCW limit inputs in the CJ1M are as follows: CW: A540.08, CCW: A540.09 for pulse output 0 and CW: A541.08, CCW: A541.09 for pulse output 1. Accordingly, the actual inputs can be used as the CW/CCW limit by outputting the flags below in the ladder program.

Example)



- *2. The XB and YB contacts are used to turn ON/OFF the electromagnetic brake.
- *3. Connection to the MING input terminal is disabled.
- *4. Do not connect unused terminals.
- *5. The 0 V terminal is internally connected to the common terminals.
- *6. The applicable crimp terminal is R1.25-3 (round with open end).

Linear Servo Drive Cable (XW2Z-xJ-B31)

This cable connects the drive to a Servo Relay Unit (XW2B-20J6-8A, XW2B-40J6-9A).

Cable types

Model	Length (L)	Outer diameter of sheath	Weight
XW2Z-100J-B31	1 m	8.1 dia.	Approx. 0.1 kg
XW2Z-200J-B31	2 m		Approx. 0.2 kg

Connection configuration and external dimensions

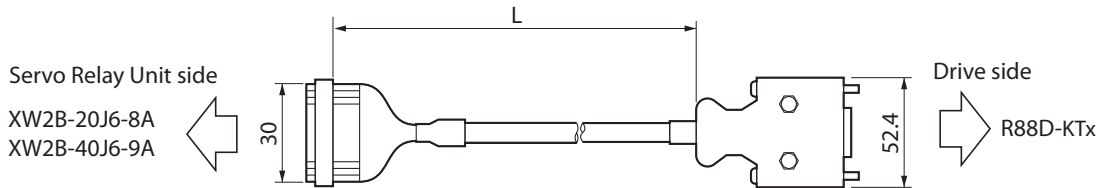

Wiring

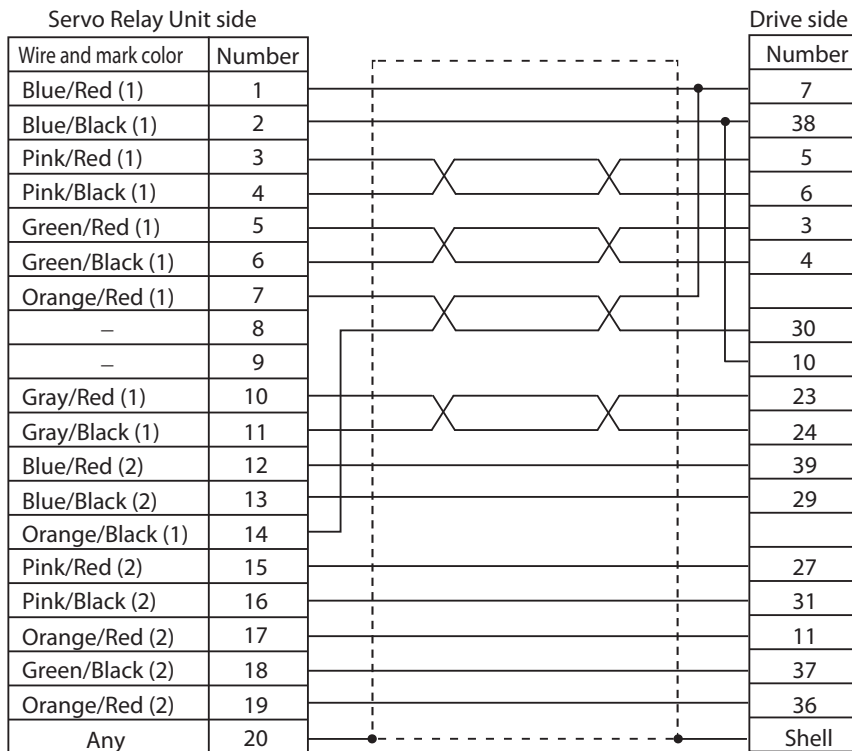

[Servo Relay Unit connector]

Connector socket model: XG4M-2030

Strain relief model: XG4T-2004

[Cable]

AWG28 × 10P UL2464

[Drive connector]

Connector plug model: 10150-3000PE (Sumitomo 3M)

Connector case model: 10350-52A0-008 (Sumitomo 3M)

Position Control Unit-Servo Relay Unit Cable Specifications

Position Control Unit Cable (XW2Z-xJ-A3)

This cable connects a Programmable Controller (CQM1H-PLB21) to a Servo Relay Unit (XW2B-20J6-3B).

Cable types

Model	Length (L)	Outer diameter of sheath	Weight
XW2Z-050J-A3	50 cm	7.5 dia.	Approx. 0.1 kg
XW2Z-100J-A3	1 m		Approx. 0.1 kg

Connection configuration and external dimensions

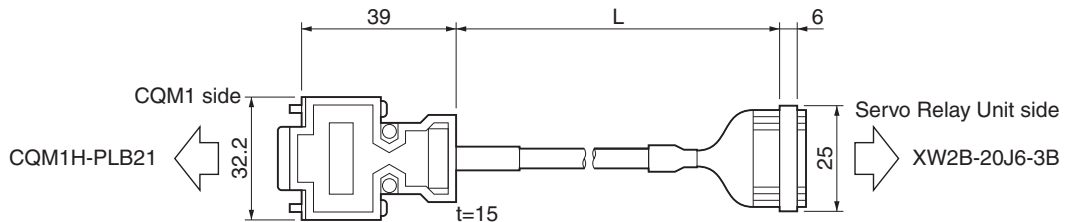

Wiring

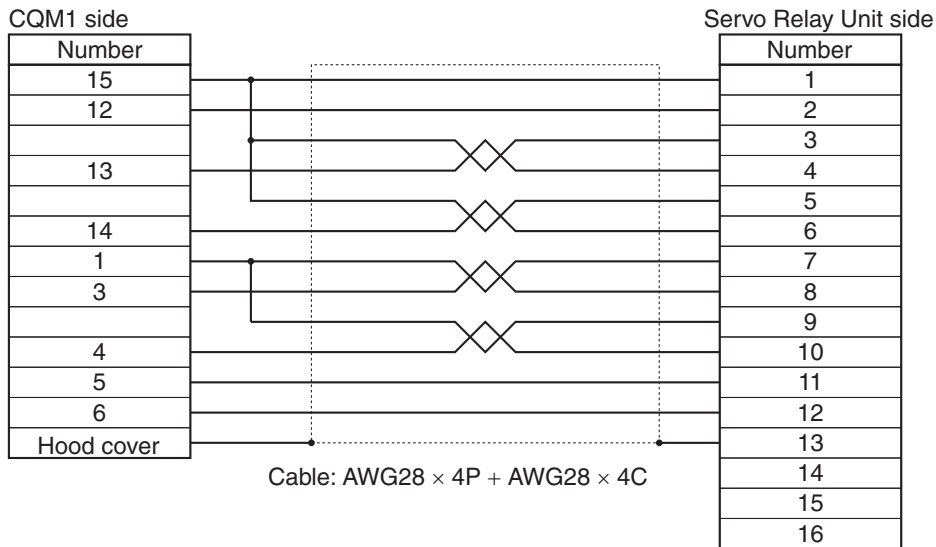

Position Control Unit Cable (XW2Z-xJ-A6)

This cable connects a Position Control Unit (CS1W-NC113 and C200HW-NC113) to a Servo Relay Unit (XW2B-20J6-1B).

Cable types

Model	Length (L)	Outer diameter of sheath	Weight
XW2Z-050J-A6	50 cm	8.0 dia.	Approx. 0.1 kg
XW2Z-100J-A6	1 m		Approx. 0.1 kg

Connection configuration and external dimensions

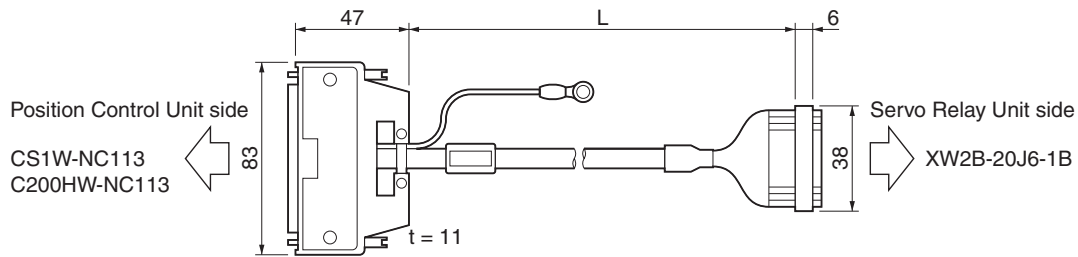

Wiring

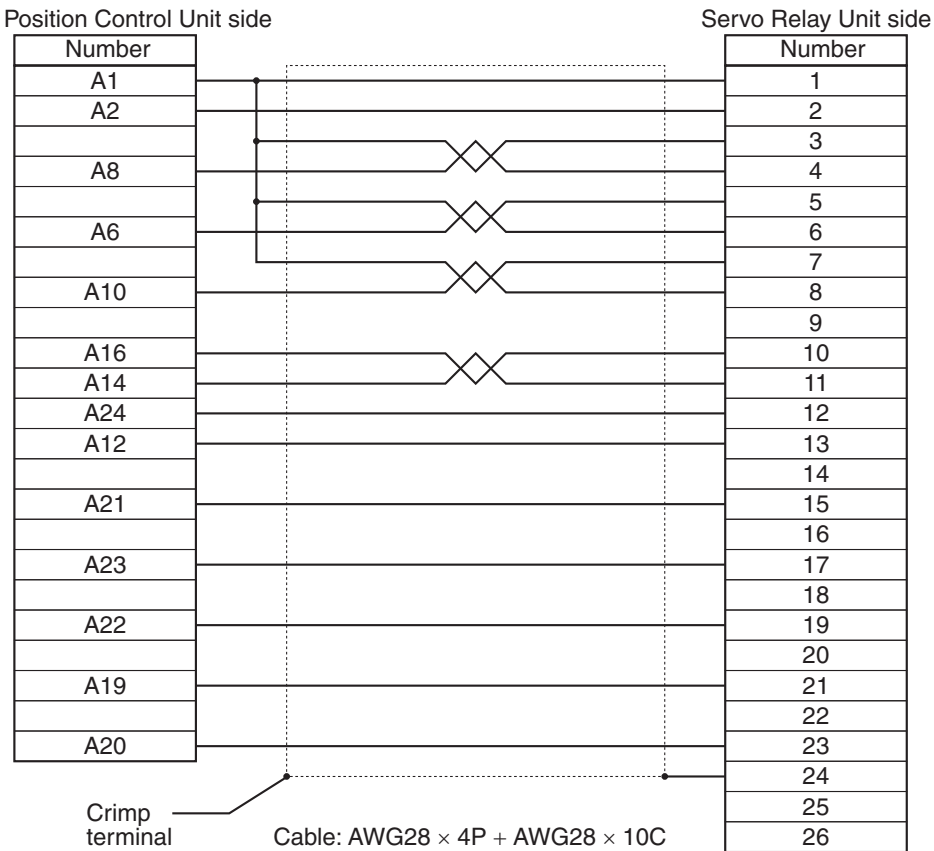

Position Control Unit Cable (XW2Z-xJ-A7)

This cable connects a Position Control Unit (CS1W-NC213/NC413 and C200HW-NC213/NC413) to a Servo Relay Unit (XW2B-40J6-2B).

Cable types

Model	Length (L)	Outer diameter of sheath	Weight
XW2Z-050J-A7	50 cm	10.0 dia.	Approx. 0.1 kg
XW2Z-100J-A7	1 m		Approx. 0.2 kg

Connection configuration and external dimensions

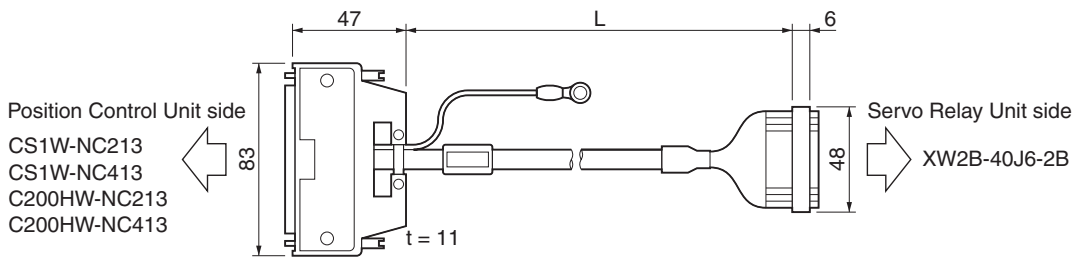

Wiring

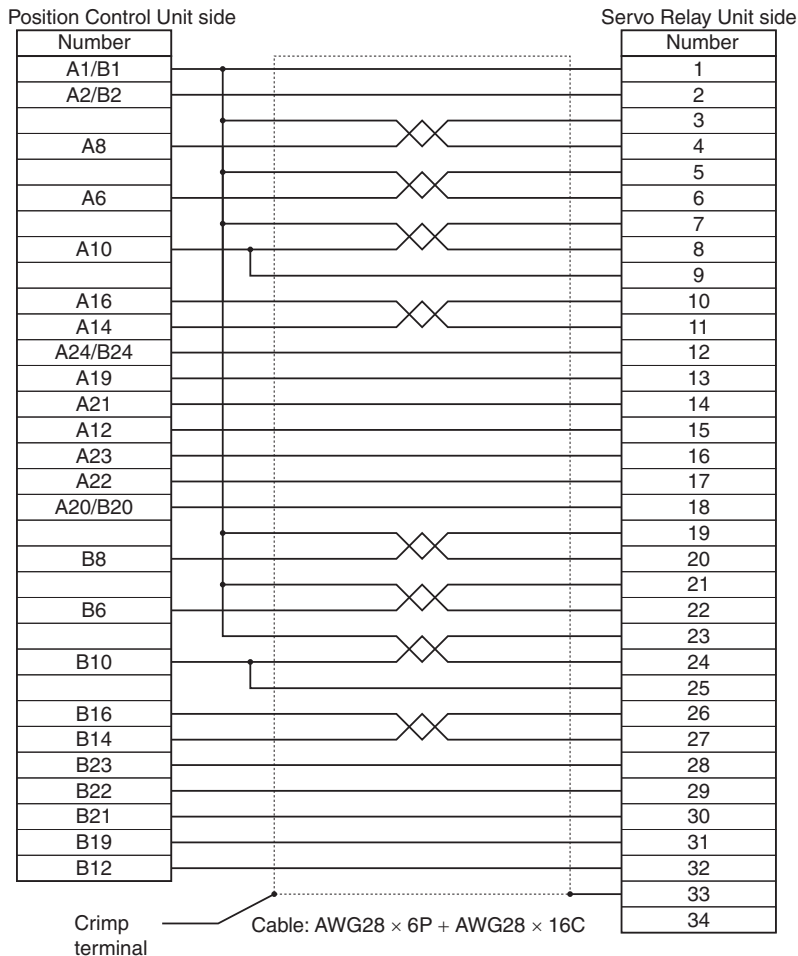

Position Control Unit Cable (XW2Z-xJ-A10)

This cable connects a Position Control Unit (CS1W-NC133) to a Servo Relay Unit (XW2B-20J6-1B).

Cable types

Model	Length (L)	Outer diameter of sheath	Weight
XW2Z-050J-A10	50 cm	10.0 dia.	Approx. 0.1 kg
XW2Z-100J-A10	1 m		Approx. 0.2 kg

Connection configuration and external dimensions

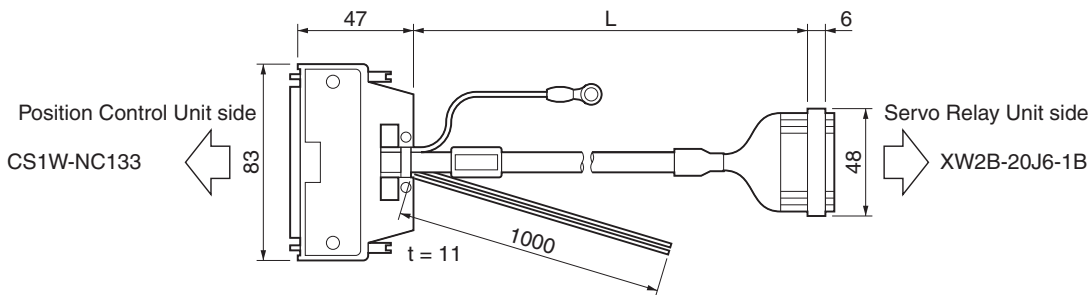

Wiring

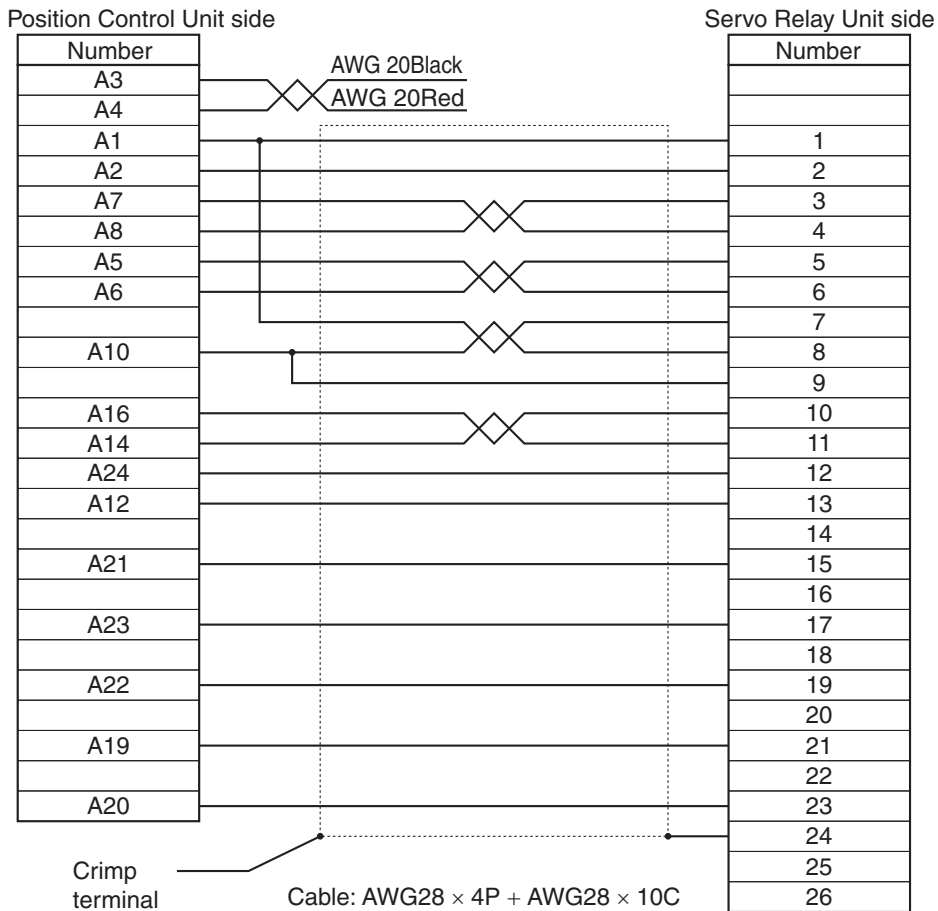

Position Control Unit Cable (XW2Z-xJ-A11)

This cable connects a Position Control Unit (CS1W-NC233/433) to a Servo Relay Unit (XW2B-40J6-1B).

Cable types

Model	Length (L)	Outer diameter of sheath	Weight
XW2Z-050J-A11	50 cm	10.0 dia.	Approx. 0.1 kg
XW2Z-100J-A11	1 m		Approx. 0.2 kg

Connection configuration and external dimensions

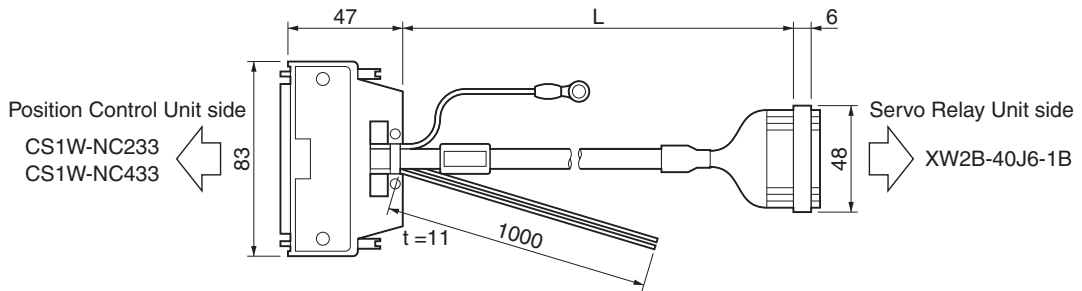

Wiring

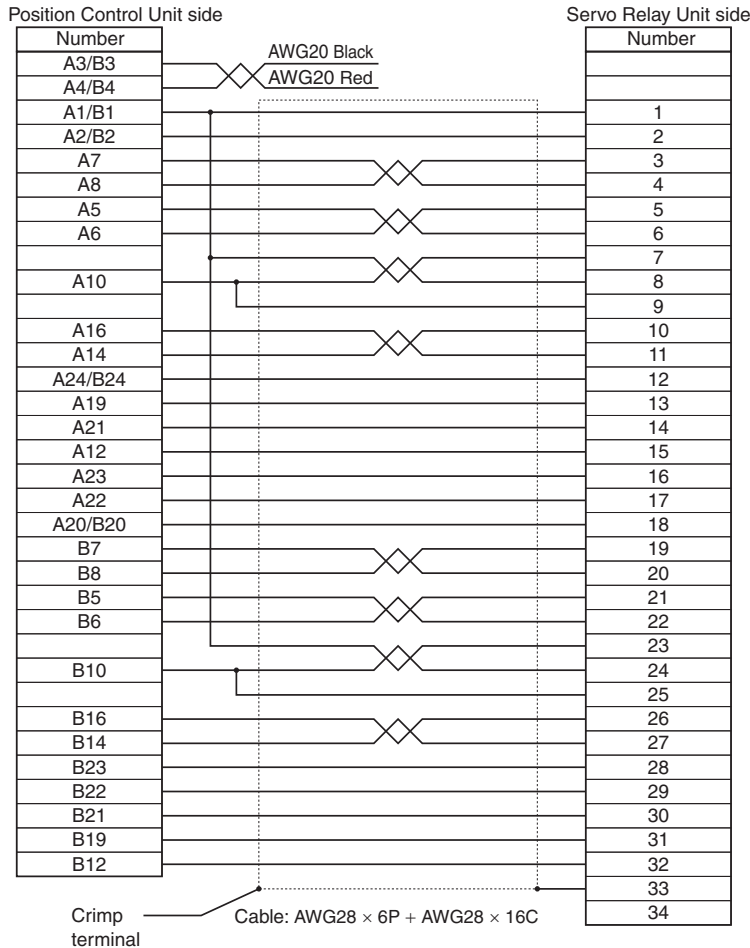

Position Control Unit Cable (XW2Z-xJ-A14)

This cable connects a Position Control Unit (CJ1W-NC113) to a Servo Relay Unit (XW2B-20J6-1B).

Cable types

Model	Length (L)	Outer diameter of sheath	Weight
XW2Z-050J-A14	50 cm	10.0 dia.	Approx. 0.1 kg
XW2Z-100J-A14	1 m		Approx. 0.2 kg

Connection configuration and external dimensions

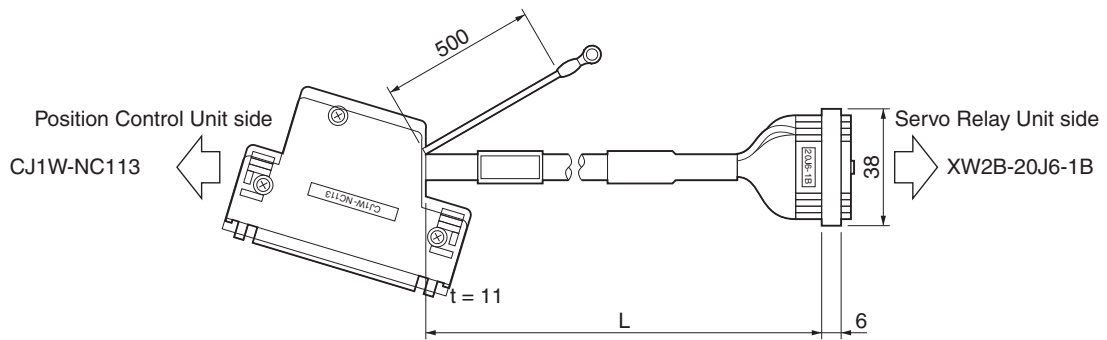

Wiring

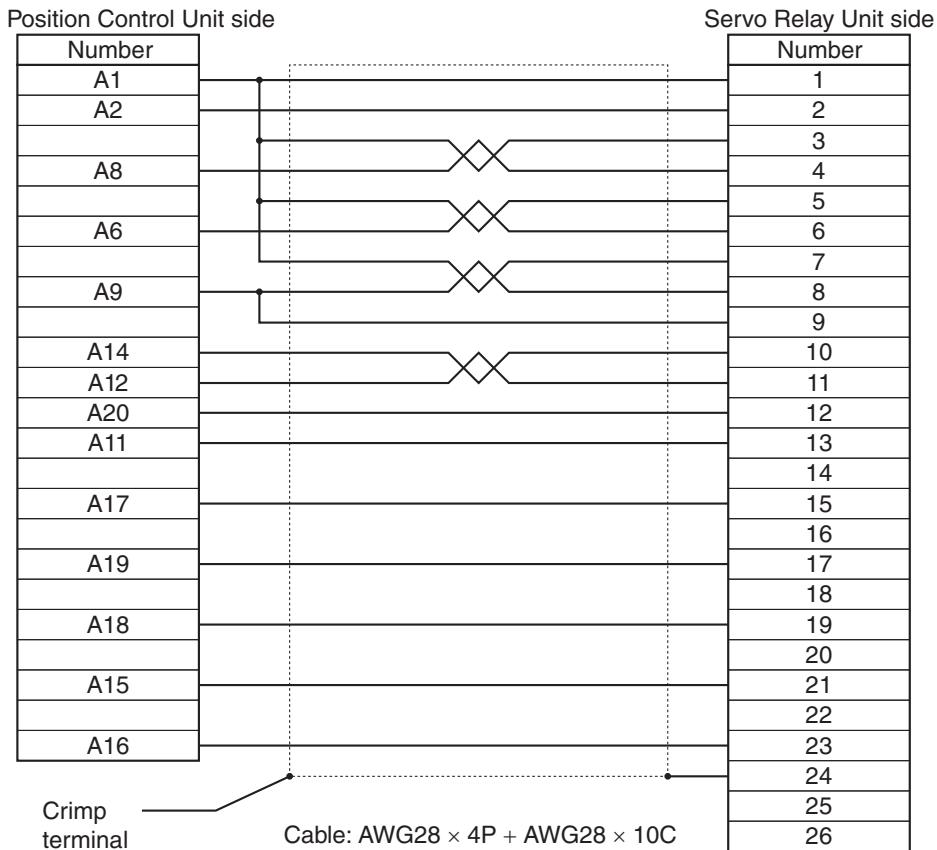

Position Control Unit Cable (XW2Z-xJ-A15)

This cable connects a Position Control Unit (CJ1W-NC213/NC413) to a Servo Relay Unit (XW2B-40J6-2B).

Cable types

Model	Length (L)	Outer diameter of sheath	Weight
XW2Z-050J-A15	50 cm	10.0 dia.	Approx. 0.1 kg
XW2Z-100J-A15	1 m		Approx. 0.2 kg

Connection configuration and external dimensions

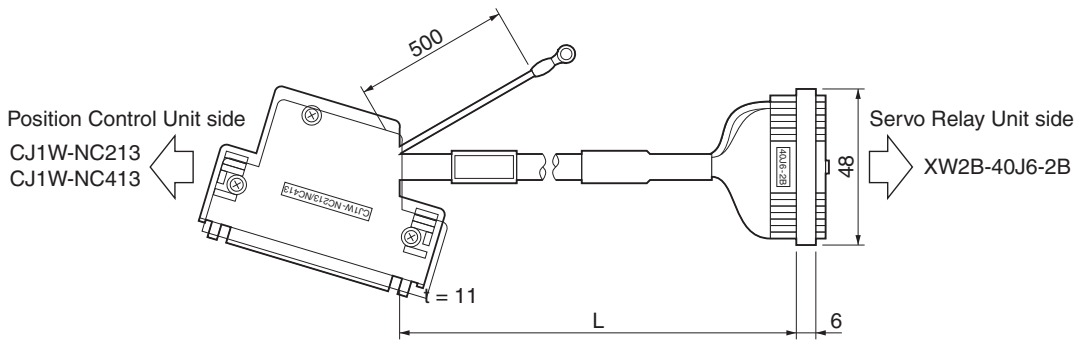

Wiring

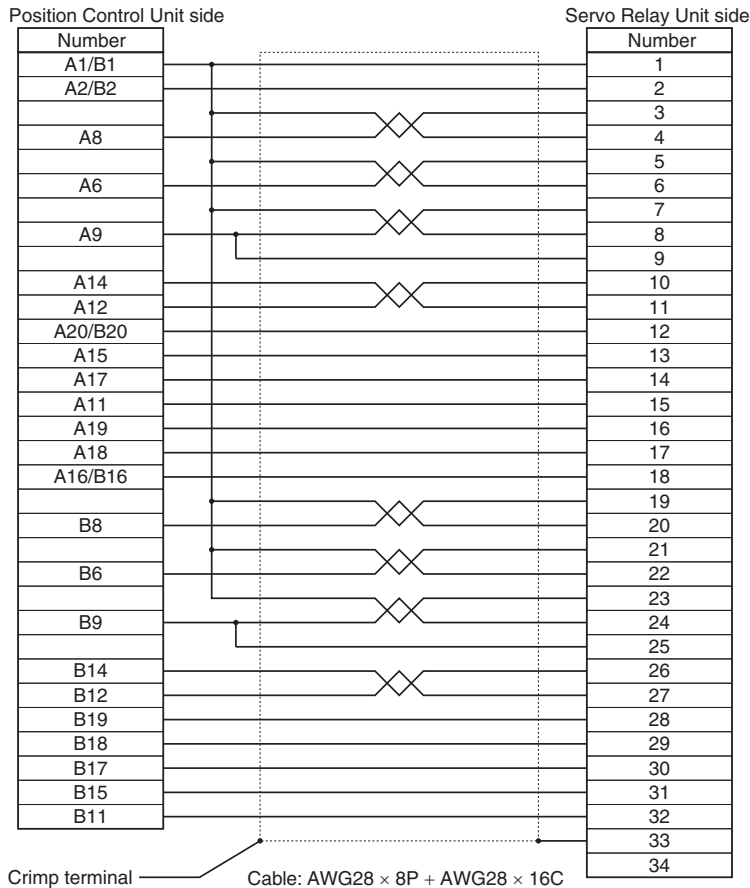

Position Control Unit Cable (XW2Z-xJ-A18)

This cable connects a Position Control Unit (CJ1W-NC133) to a Servo Relay Unit (XW2B-20J6-1B).

Cable types

Model	Length (L)	Outer diameter of sheath	Weight
XW2Z-050J-A18	50 cm	10.0 dia.	Approx. 0.1 kg
XW2Z-100J-A18	1 m		Approx. 0.2 kg

Connection configuration and external dimensions

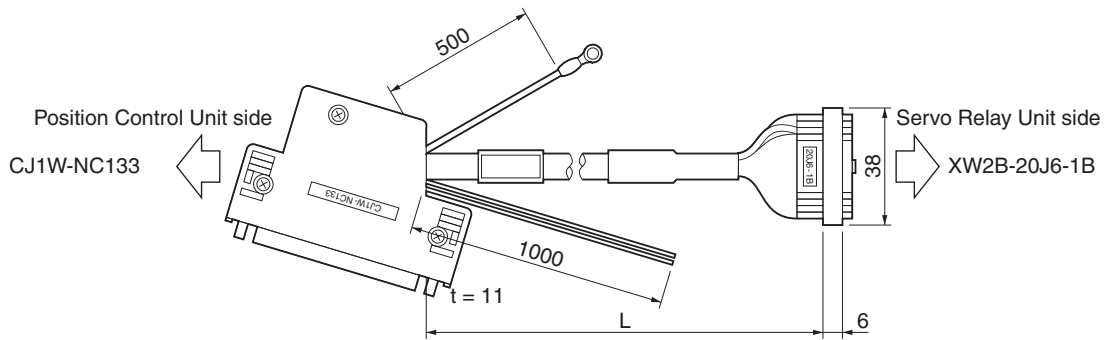

Wiring

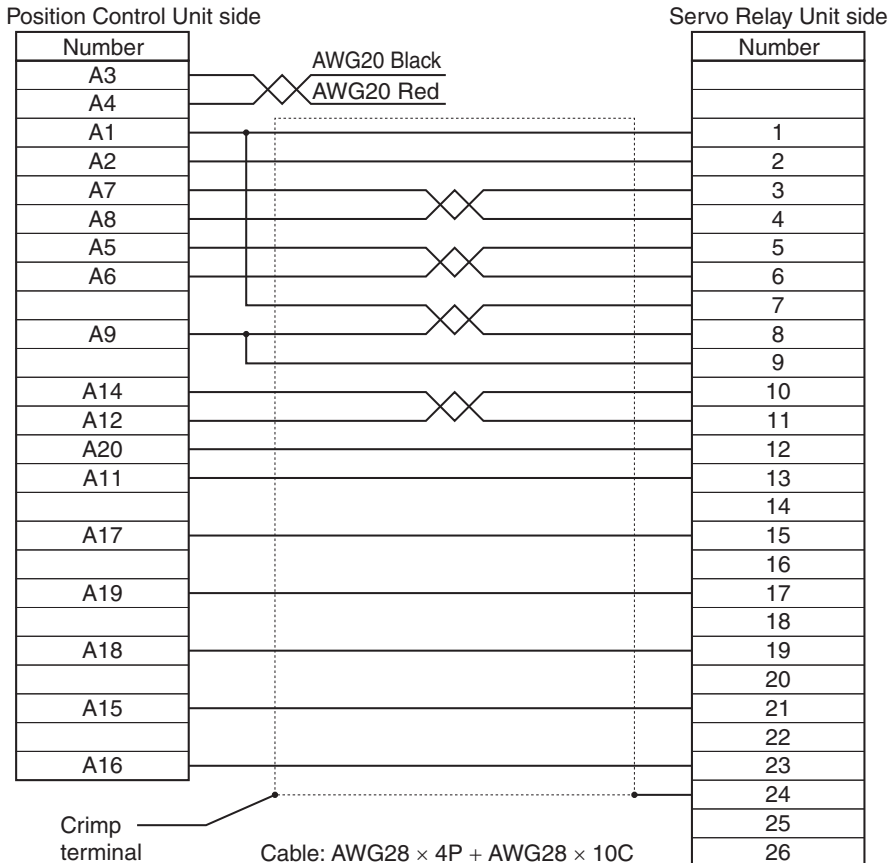

Position Control Unit Cable (XW2Z-xJ-A19)

This cable connects a Position Control Unit (CJ1W-NC233/433) to a Servo Relay Unit (XW2B-40J6-2B).

Cable types

Model	Length (L)	Outer diameter of sheath	Weight
XW2Z-050J-A19	50 cm	10.0 dia.	Approx. 0.1 kg
XW2Z-100J-A19	1 m		Approx. 0.2 kg

Connection configuration and external dimensions

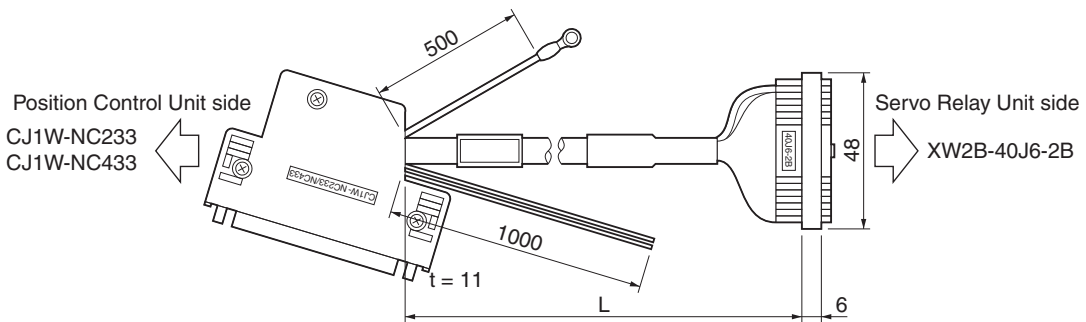

Wiring

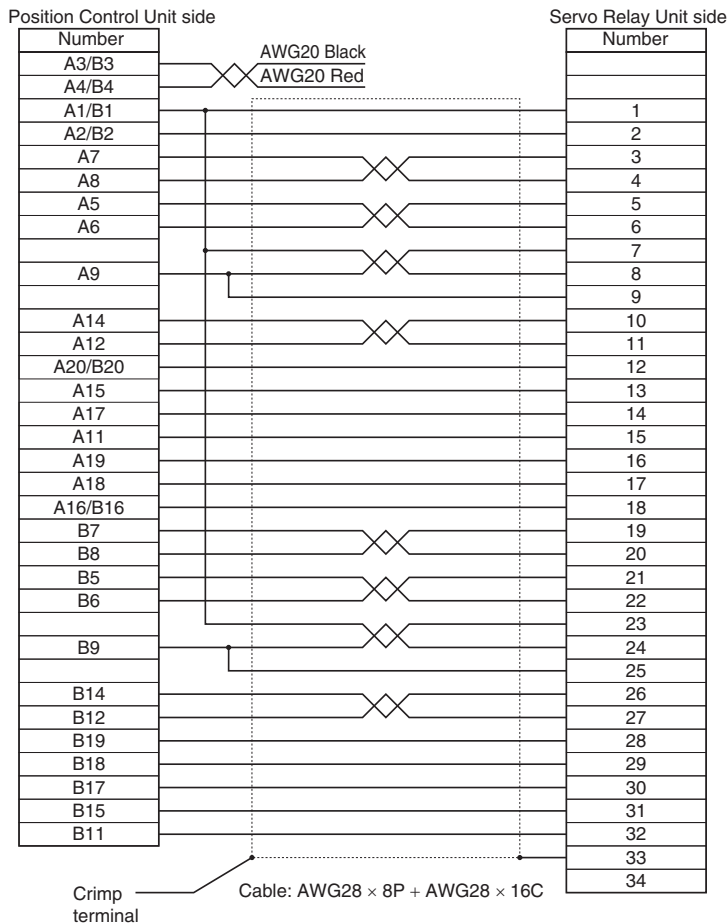

3-7 External Regeneration Resistor Specifications

External Regeneration Resistor Specifications

R88A-RR08050S

Model	Resistance value	Nominal capacity	Regeneration absorption for 120°C temperature rise	Heat radiation condition	Thermal switch output specifications
R88A-RR08050S	50 Ω	80 W	20 W	Aluminum 250 × 250, Thickness: 3.0	Operating temperature 150°C ± 5% NC contact Rated output: 30 VDC, 50 mA max.

R88A-RR080100S

Model	Resistance value	Nominal capacity	Regeneration absorption for 120°C temperature rise	Heat radiation condition	Thermal switch output specifications
R88A-RR080100S	100 Ω	80 W	20 W	Aluminum 250 × 250, Thickness: 3.0	Operating temperature 150°C ± 5% NC contact Rated output: 30 VDC, 50 mA max.

R88A-RR22047S

Model	Resistance value	Nominal capacity	Regeneration absorption for 120°C temperature rise	Heat radiation condition	Thermal switch output specifications
R88A-RR22047S	47 Ω	220 W	70 W	Aluminum 350 × 350, Thickness: 3.0	Operating temperature: 170°C ± 7°C NC contact Rated output: 250 VAC, 0.2 A max.

R88A-RR50020S

Model	Resistance value	Nominal capacity	Regeneration absorption for 120°C temperature rise	Heat radiation condition	Thermal switch output specifications
R88A-RR50020S	20 Ω	500 W	180 W	Aluminum 600 × 600, Thickness: 3.0	Operating temperature 200°C ± 7°C NC contact Rated output: 250 VAC, 0.2 A max. 24 VDC, 0.2 A max.

3-8 EMC Filter Specifications

Specifications

Applicable Linear servodrive	Filter model	Rated current	Leakage current	Rated voltage
R88D-KT02H-L	R88A-FIK102-RE	2.4 A	3.5 mA	250 VAC single-phase
R88D-KT04H-L	R88A-FIK104-RE	4.1 A		
R88D-KT08H-L	R88A-FIK107-RE	6.6 A		
R88D-KT10H-L	R88A-FIK114-RE	14.2 A		
R88D-KT15H-L				
R88D-KT06F-L	R88A-FIK304-RE	4 A		400 VAC single-phase
R88D-KT10F-L				
R88D-KT15F-L				
R88D-KT20F-L	R88A-FIK306-RE	6 A		
R88D-KT30F-L	R88A-FIK312-RE	12 A		
R88D-KT50F-L				

4

System Design

This chapter explains the installation conditions, wiring methods including wiring conforming to EMC directives and how to calculate the regenerative energy depending on Servo Drive, Linear Servo Motor and application characteristics.

4-1	Installation Conditions	4-2
	Servo Drive Installation Conditions	4-2
	Iron-core Installation Conditions	4-4
	Ironless Installation Conditions	4-13
4-2	Wiring.....	4-16
	Peripheral Equipment Connection Examples	4-16
	Main Circuit and Motor Connections.....	4-22
4-3	Wiring Conforming to EMC Directives.....	4-30
	Wiring Method.....	4-30
	Selecting Connection Component	4-35
4-4	Regenerative Energy Absorption.....	4-44
	Calculating the Regenerative Energy	4-44
	Drive Regeneration Absorption Capacity.....	4-46
	Regenerative Energy Absorption with an External Regeneration Resistor.....	4-47
	Connecting an External Regeneration Resistor.....	4-48

4-1 Installation Conditions

Servo Drive Installation Conditions

Dimension Conditions around Equipment

- ◆ Install drives according to the dimensions shown in the following illustration to ensure proper heat dispersion inside the drive and convection inside the panel. If the drives are installed side by side, install a fan for air circulation to prevent uneven temperatures inside the panel.

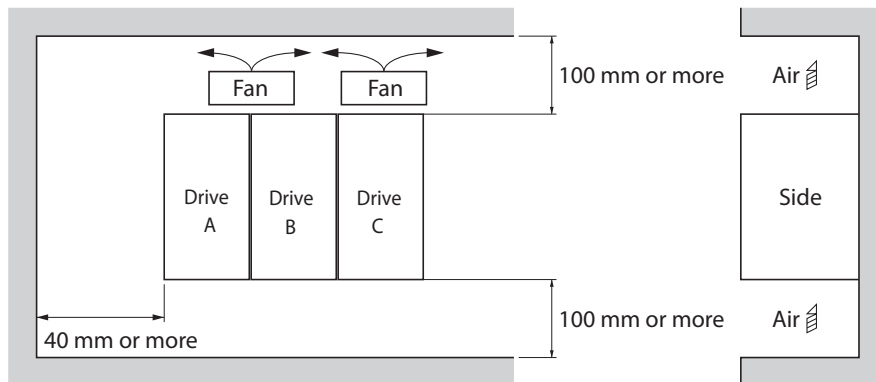

- ◆ For side-by-side installation you have to apply next derating for models of 800W or less: Installed in position A, maximum ambient temperature 50°C, installed in position B, maximum ambient temperature 40°C and installed in position C, maximum ambient temperature 45°C.

Mounting Direction

- ◆ Mount the drives in a direction (perpendicular) so that the model number can be seen properly.

Environment Operating Conditions

- ◆ The environment in which drives are operated must meet the following conditions. Drives may malfunction if operated under any other conditions.
 - Operating ambient temperature: 0 to +55°C (Take into account temperature rises in the following individual drives themselves.)
 - Operating humidity: 90% RH max. (with no condensation)
 - Operating atmosphere: No corrosive gases.
 - Altitude: 1,000 m max.
 - Derating must be applied for higher altitudes.

Ambient Temperature Control

- ◆ To operate in environments in which there is minimal temperature rise is recommended to maintain a high level of reliability.
- ◆ When the drive is installed in a closed space, such as a box, ambient temperature will rise due to temperature rise in each unit. Use a fan or air conditioner to prevent the drive's ambient temperature from exceeding 55°C.
- ◆ Drive surface temperatures may rise to as much as 30°C above the ambient temperature. Use heat-resistant materials for wiring, and keep its distance from any devices or wiring that are sensitive to heat.
- ◆ The limit of a drive is largely determined by the ambient temperature around the internal electrolytic capacitors. When an electrolytic capacitor reaches its limit, electrostatic capacity drops.

- ♦ If a drive is always operated at the ambient temperature of 55°C and with 100% output of the rated force and rated movement speed, its limit is expected to be approx. 28,000 hours (excluding the axial-flow fan). A drop of 10°C in the ambient temperature will double the expected limit for drive.

$$\text{Lifetime } 25^{\circ}\text{C} = \text{Lifetime } 55^{\circ}\text{C} \times 2^{\frac{55-25}{10}} = 224000 \text{ hour}$$

Keeping Foreign Objects Out of Units

- ♦ Place a cover over the drive or take other preventative measures to prevent foreign objects, such as drill filings, from getting into the drive during installation. Be sure to remove the cover after installation is complete. If the cover is left on during operation, drive's heat dissipation is blocked, which may result in malfunction.
- ♦ Take measures during installation and operation to prevent foreign objects such as metal particles, oil, machining oil, dust, or water from getting inside of drives.

Iron-core Installation Conditions

Components

- ♦ An Iron-core Linear Motor is not a system by itself. Before the linear motor can be run it has to be assembled together with the proper elements.
- ♦ Apart from the drive, OMRON supplies the next elements:
 - Linear motor coil.
 - Magnet track(s).
 - Cables.
 - Hall sensor (optional).
 - Serial Converter (optional).
- ♦ In order to make a proper installation, the user must provide next elements:
 - Linear encoder and read head (can be A/B line drive pulses or SinCos). If using A/B pulse use a resolution of at least 50 μ m per pulse. Lower resolutions are acceptable for SinCos Encoder as the interpolation is higher.
 - Linear guides and slider (recirculating ball bearing type). Recommended model is THK SSR series or similar. Dimension according to the load weight, motor model, machine dynamics and necessary lifetime.
 - A base frame and a top table to assemble the parts together.
 - A cable chain.
- ♦ See the example drawing for all the parts:

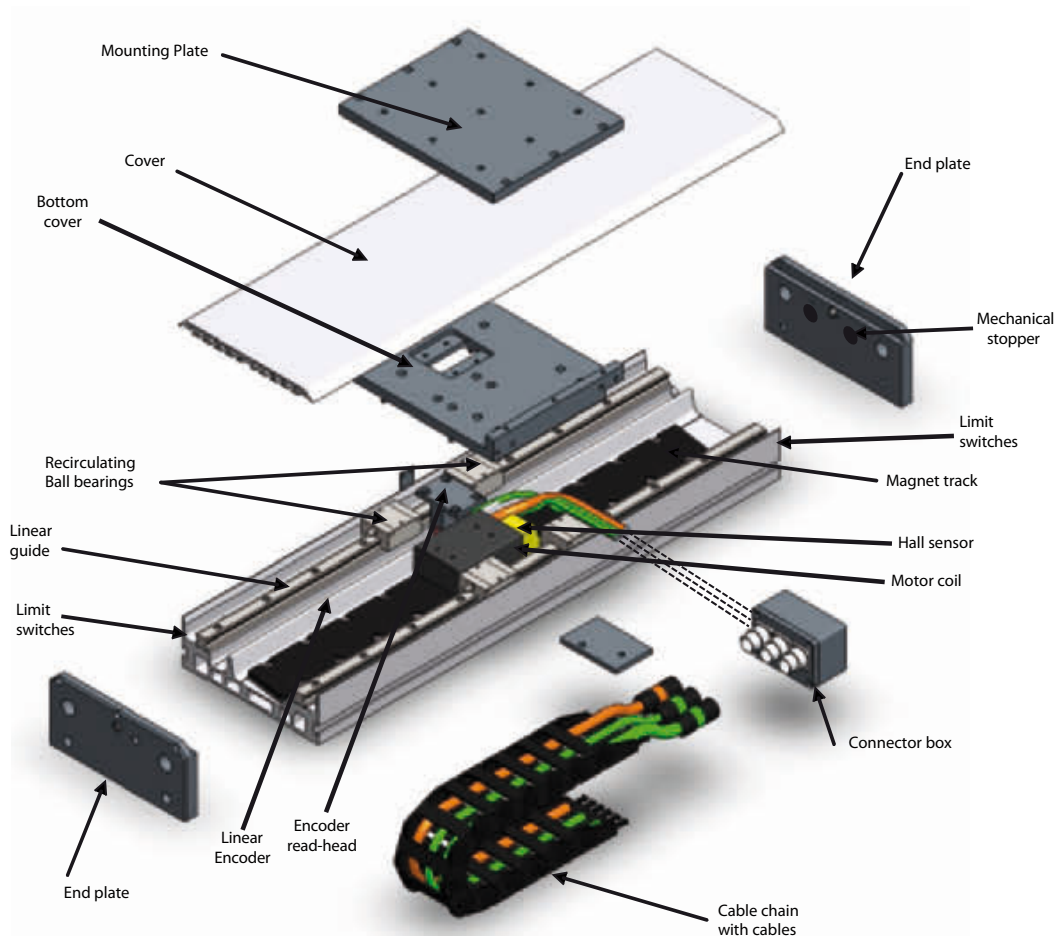

Installation conditions

Mechanical Tolerances

- ♦ The flatness of the mounting surface for the coil unit must be better than 0.1mm.
- ♦ The flatness of the mounting base has to be of 0.1mm/m or better.
- ♦ The Coil unit has to be mounted parallel to the magnet tracks. The parallelism has to be better than 0.2mm.
- ♦ The separation between magnets and coil has to be 0.3mm +/-0.1mm.
- ♦ Sideward positioning of the coil unit to the magnet plates is not very critical. A tolerance of up to +/-0.5mm is acceptable.

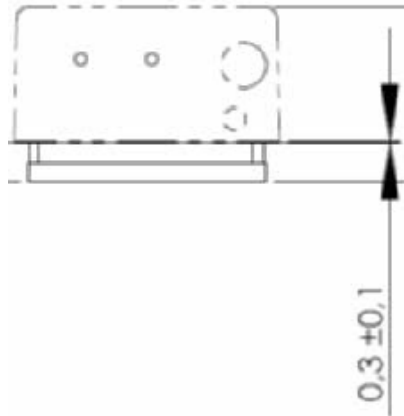

Thermal Consideration

- ♦ The linear motor coil becomes hot when running. Take care to install the motor to a top table of the recommended dimensions in a well ventilated place.
- ♦ Make sure there is a good thermal contact between the motor coil and the top table. Use thermal-conductive silicon to ensure a good thermal transmission.
- ♦ If the temperature rise must be reduced (because the application does not allow the expansion due to temperature, or because the top table is smaller than the required one, etc.) install a cooling system to cool the motor.

Linear System Rigidity

The rigidity of a linear system put the limit to the gains you can set in the drive an, hence, to performance and accuracy you can reach.

Design the rigidity according to the performance you need to reach. The maximum gain you can set in the speed loop corresponds with the mechanical bandwidth of the linear motor system.

In order to increase the rigidity you can:

- ♦ Use pre-loaded linear guides.
- ♦ Install the linear motor system in a rigid base. From more rigid to less rigid we can use Granite, steel or aluminium.
- ♦ The top table has to be thick enough to avoid deformation or vibration.
- ♦ Install the magnet tracks, motor coil and encoder straight and parallel.
- ♦ Install the encoder as close as possible to the motor coil.

Installation steps

- ♦ Install the linear encoder to the base frame according to the linear encoder maker instructions. Install close to the motor coil to avoid errors due to torsional effects.

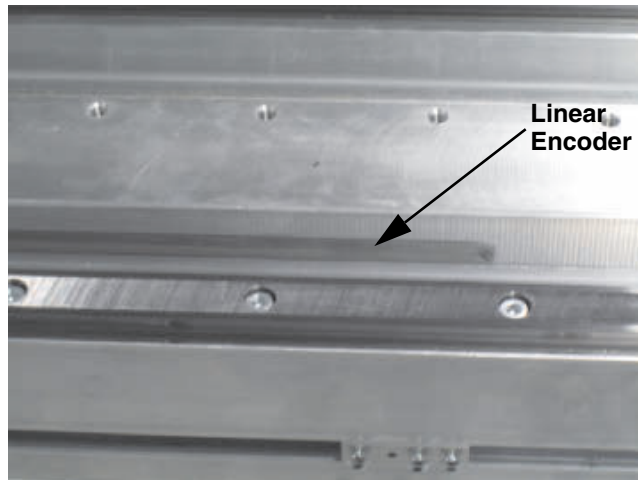

- ♦ Install the linear guides to the base frame according to the linear guide maker instructions.

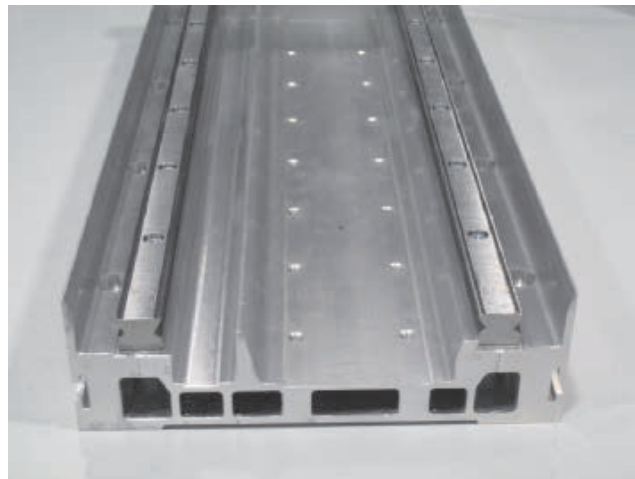

- ♦ Install the linear ball-bearing, the motor coil and the encoder read head in the Top table. Make sure the positive direction of the coil and the positive direction of the encoder read head correspond. Otherwise, this can be changed by parameter.

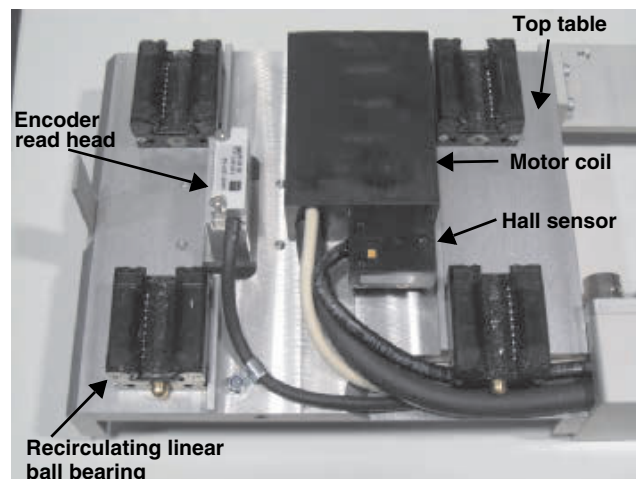

- ♦ Dimension the top table and the linear guides according to the total weight to move, the dynamics and the attraction forces between magnets and coil.
- ♦ The attraction forces are:

Motor	Attraction force
R88L-EC-FW-0303	300N
R88L-EC-FW-0306	500N
R88L-EC-FW-0606	1020N
R88L-EC-FW-0609	1420N
R88L-EC-FW-0612	1820N
R88L-EC-FW-1112	3640N
R88L-EC-FW-1115	4440N

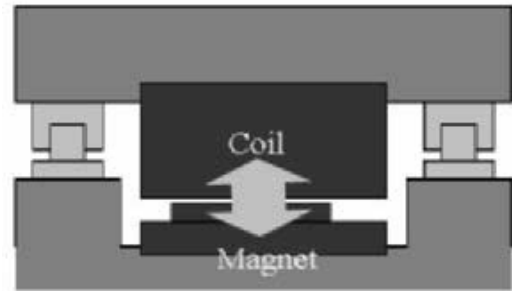

- ♦ Use next bolts for the coil unit:

Bolts for coil unit	R88L-EC-FW-0303 R88L-EC-FW-0306	R88L-EC-FW-0606 R88L-EC-FW-0609 R88L-EC-FW-0612	R88L-EC-FW-1112 R88L-EC-FW-1115
	Bolts (steel)	M4	M5
Depth bolt in thread hole	Min: 4mm Max: 5mm	Min: 4mm Max: 5mm	Min: 4.5mm Max: 6.5mm
Tightening force	2.0 - 3.0 Nm		3.0 - 5.0 Nm

- ♦ Gently introduce the ball-bearing in the top table into the linear guides.

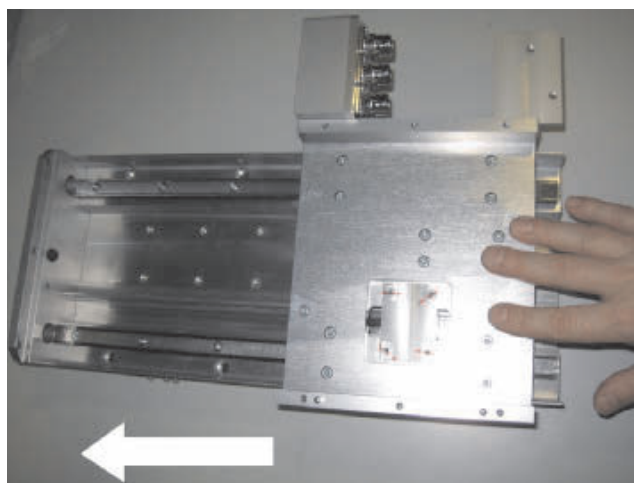
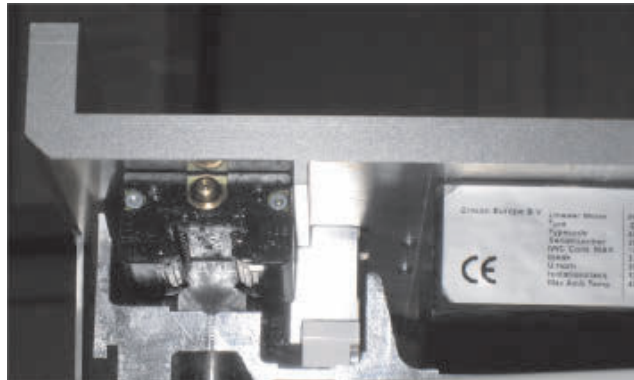

4-1 Installation Conditions

- ◆ Attach an end plate or stopper to prevent that, accidentally the motor leave the slider.

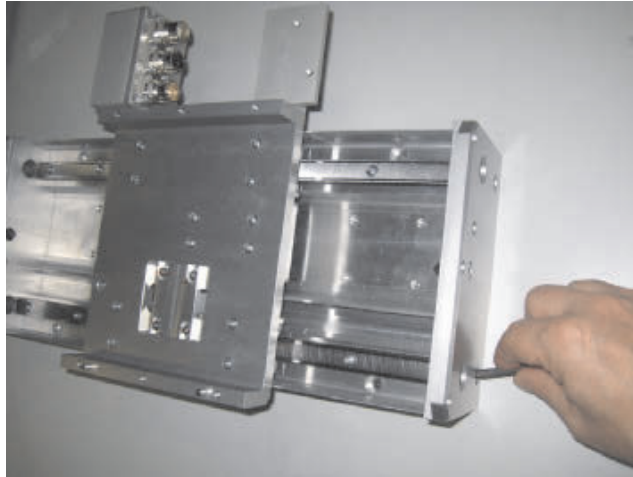

- ◆ In order to install the magnet track move the top table to one side of the slider and secure so it's not moving.

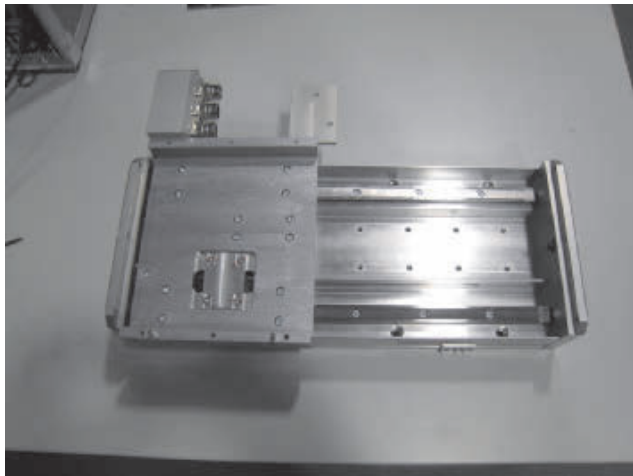
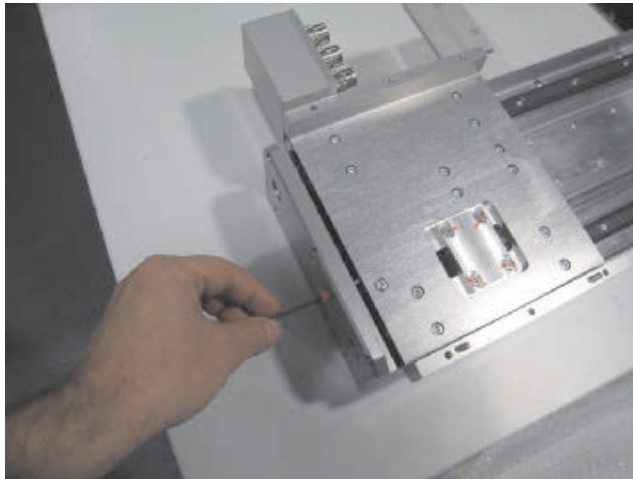

- ♦ The magnet comes with a protection plate to reduce the effect of the magnetic field. Do not remove the protection plate until the magnet track has been completely installed.

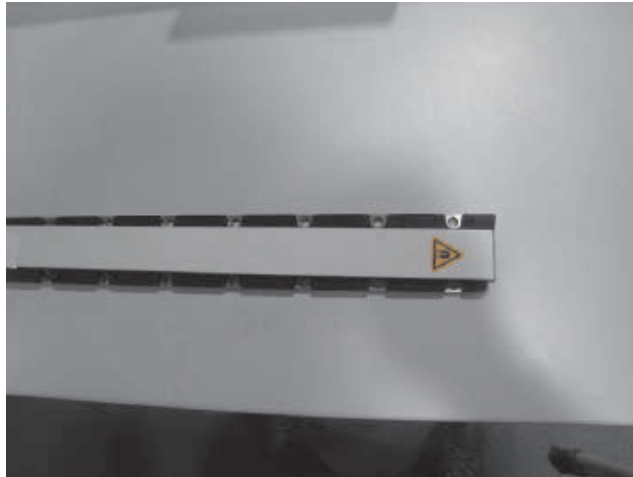

- ♦ Install the first magnet in the free side of the slider. So you can work without problems due to the attraction force between coil and magnet.

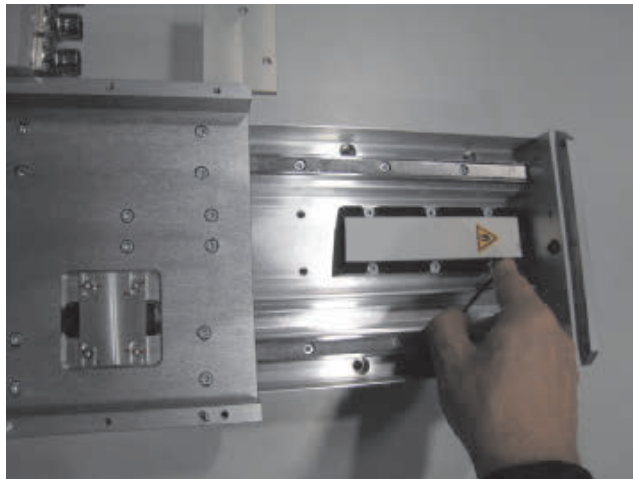

- ♦ If the slider is not long enough for this operation, remove the end plate and install dummy guides in order to leave the necessary space for the motor installation and be able to move the motor coil again without problems due to the attraction forces.

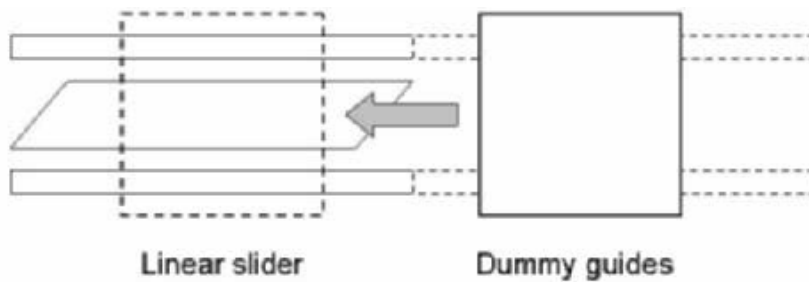

- ♦ Use next bolts for the magnet tracks:

Features	R88L-EC-FW-0303 R88L-EC-FW-0306	R88L-EC-FW-0606 R88L-EC-FW-0609 R88L-EC-FW-0612	R88L-EC-FW-1112 R88L-EC-FW-1115
Bolts for magnet plates (stainless)	M5 x 10, DIN7984	M5 x 10, DIN7984	M5 x 16, DIN912

4-1 Installation Conditions

- ◆ Once installed, remove the protection plate from the magnet track, unblock the motor coil, move to the other side of the slider on top of the installed magnet and secure again.

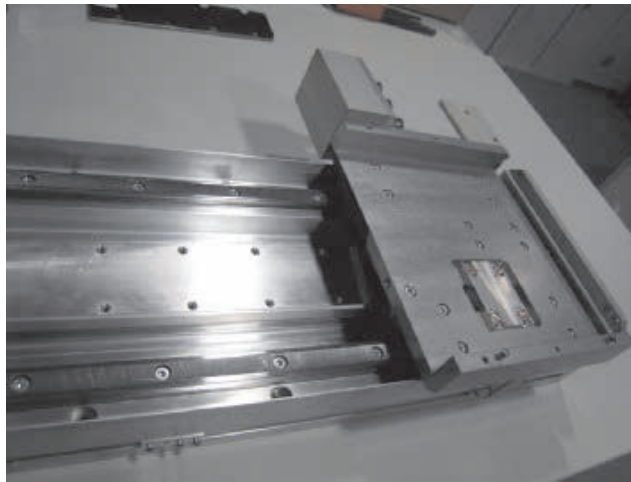
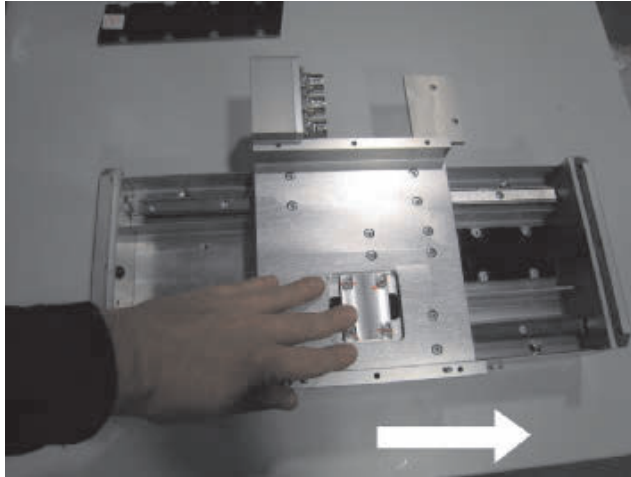

- ◆ Install the other magnets.

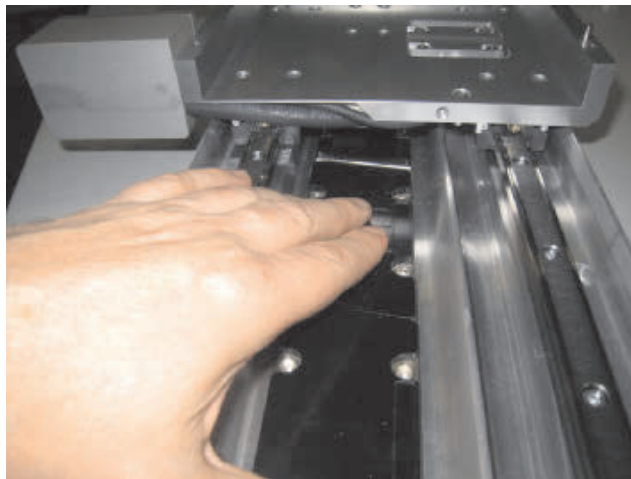

- ◆ **Note:** The protection plate has been removed for clarity of the photograph. In a real installation keep the protection plate in the magnet during this operation.

- ♦ When joining magnetic ways together, place the second magnet track in line with the first one with a certain separation to guarantee that the attraction has a negligible effect. Then, while holding the magnet track down to be sure it do not raise, push the second magnet track against the first one and secure it with bolts.

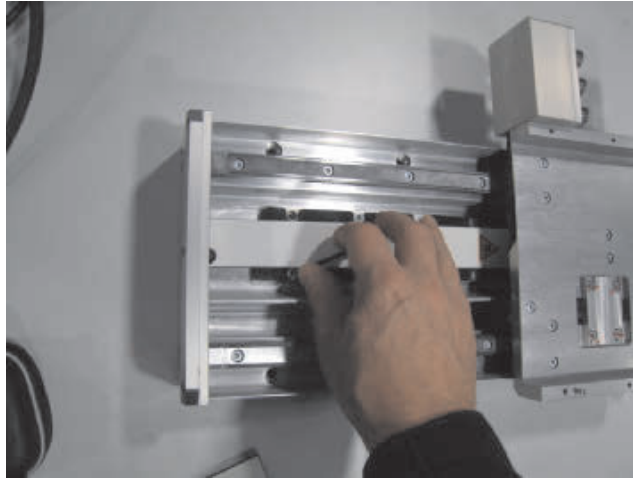

- ♦ The adjacent tracks must attract each other, if they are repelling, the tracks are wrongly orientated.
- ♦ Then, remove the protection plates of all magnets so, the top table can move freely. If necessary, check and adjust the encoder read head and verify that the installation has been done with the proper dimensions and tolerances.

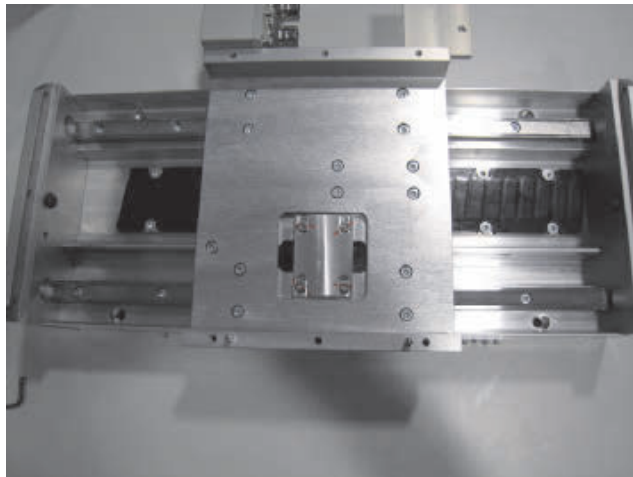

- ♦ Install a proper table chain and place the necessary cables. At least you have to put the power cable and encoder cable. Optionally you may need cables for Hall and Temperature sensors and other cables required for the machine.
- ♦ Make sure there is no torsions in the cable and install cable separators so the adjacent cables do not friction against each other.

4-1 Installation Conditions

- ♦ Make sure that the chain can support the moving speed and acceleration.

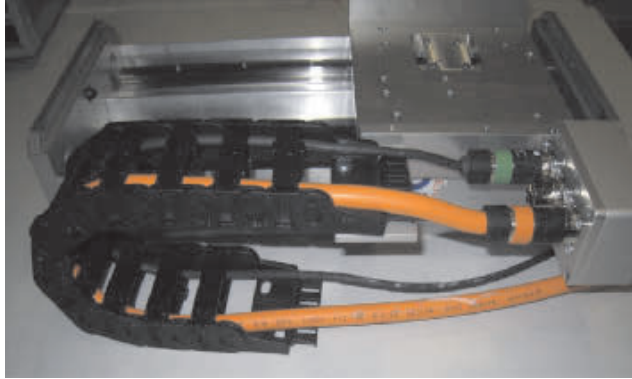

- ♦ If necessary install a linear motor cover to offer a certain protection against dust or incoming objects. Also it is recommended to install limit switches to avoid that the motor crashes against the end of the slider.

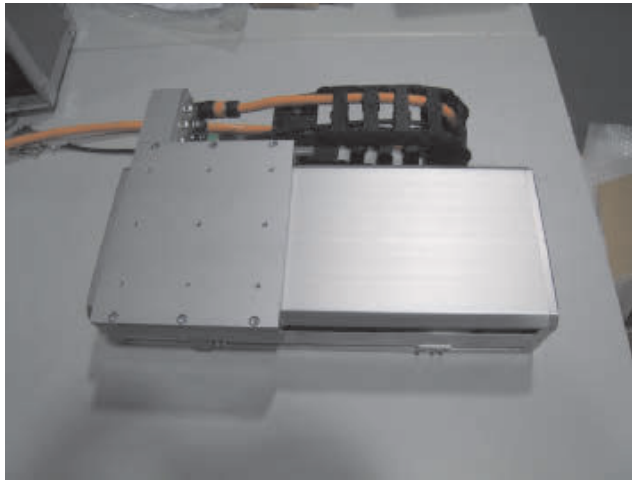

Ironless Installation Conditions

Components

- ♦ An Ironless Linear Motor is not a system by itself. Before the linear motor can be run it has to be assembled together with the proper elements.
- ♦ Apart from the drive, OMRON supplies the next elements:
 - Linear motor coil.
 - Magnet track(s).
 - Cables.
 - Hall sensor (optional).
 - Serial Converter (optional).
- ♦ In order to make a proper installation, the user must provide next elements:
 - Linear encoder and read head (can be A/B line drive pulses or SinCos).
 - Linear guides and slides (ball bearing type).
 - A base frame and a top table to assemble the parts together.
 - A cable chain.
 See the example drawing for all the parts:

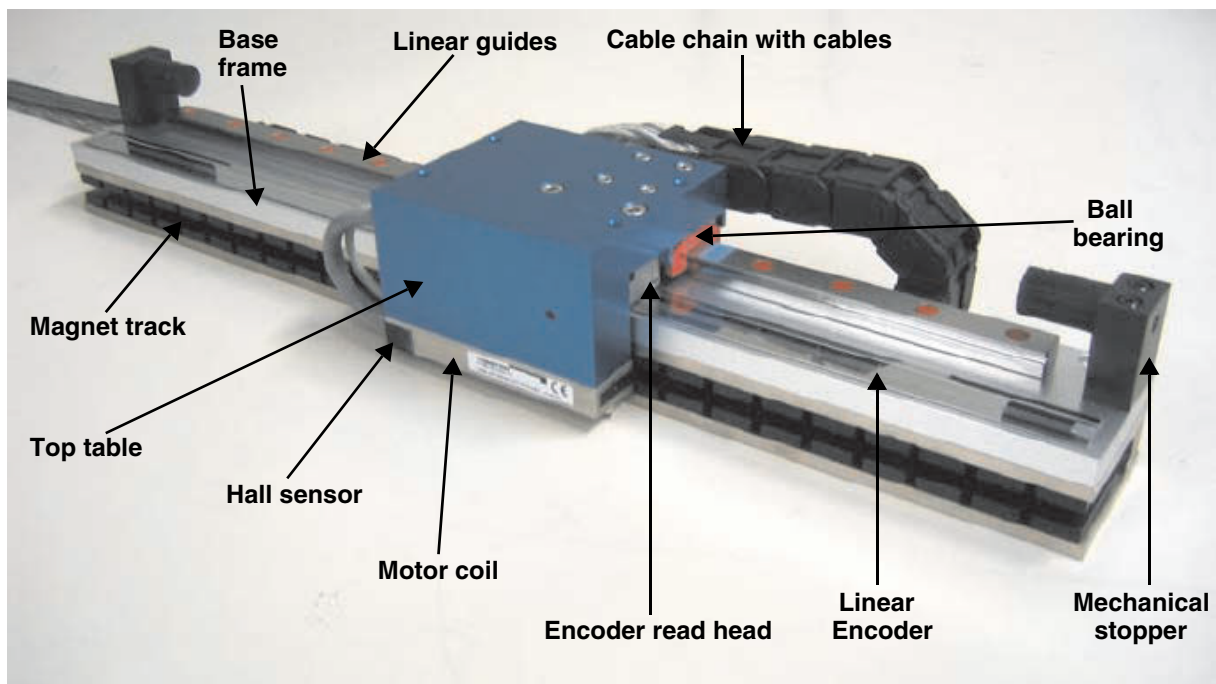

Installation conditions

Mechanical Tolerances

- ♦ The flatness of the mounting surface for the coil unit must be better than 0.1mm.
- ♦ The flatness of the mounting surface for the magnet tracks must be better than 0.1mm.
- ♦ The parallelism between coil and magnet tracks has to be better than 0.05mm in the plane perpendicular to the moving direction.

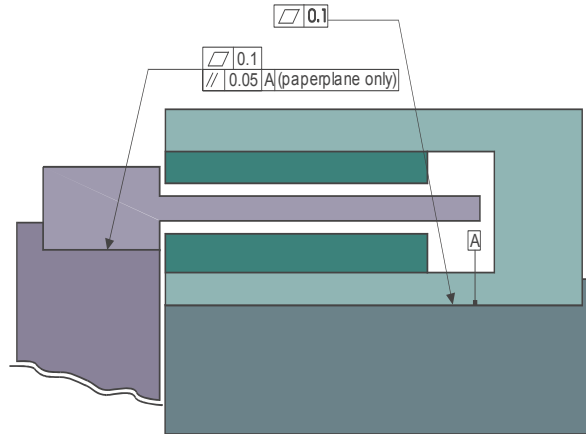

Thermal Consideration

- ♦ The linear motor coil becomes hot when running. Take care to install the motor to a top table of the recommended dimensions in a well ventilated place.
- ♦ Make sure there is a good thermal contact between the motor coil and the top table. Use thermal-conductive silicon to ensure a good thermal transmission.
- ♦ If the temperature rise must be reduced (because the application does not allow the expansion due to temperature, or because the top table is smaller than the required one, etc.) install a cooling system to cool the motor.

Linear System Rigidity

The rigidity of a linear system put the limit to the gains you can set in the drive an, hence, to the performance and accuracy you can reach.

Design the rigidity according to the performance you need to reach. The maximum gain you can set in the speed loop corresponds with the mechanical bandwidth of the linear motor system.

In order to increase the rigidity you can:

- ♦ Use pre-loaded linear guides.
- ♦ Install the linear motor system in a rigid base. From more rigid to less rigid we can use Granite, steel or aluminium.
- ♦ The top table has to be thick enough to avoid deformation or vibration.
- ♦ Install the magnet tracks, motor coil and encoder straight and parallel.
- ♦ Install the encoder as close as possible to the motor coil.

Installation steps

The installation of an ironless linear slider is similar to those with the iron-core linear motor.

The main difference is that there is no attraction force between the motor coil and the magnet track so, the installation becomes easier.

Follow the same steps than for the iron-core linear slider except for the magnet installation:

- ♦ The ironless motors do not have attraction forces between coil and magnets so, the installation is more simple than iron-core motors. But there are attraction forces between magnet tracks.
- ♦ Because a straightforward directing and placing of the magnet tracks implies the risk of striking due to magnetical forces (as well as the risk of damaged magnets), the principle of rotational mounting is recommended.



- ♦ Placement of just one magnet track on each side of the middle magnet track can be done by simply aligning the magnet track with respect to each other.
- ♦ The magnets can be mounted in every direction on respect to each other.

4-2 Wiring

Peripheral Equipment Connection Examples

R88D-KT01L-L/-KT02L-L/-KT04L-L R88D-KT02H-L/-KT04H-L/-KT08H-L/-KT10H-L/-KT15H-L (Single-phase Input)

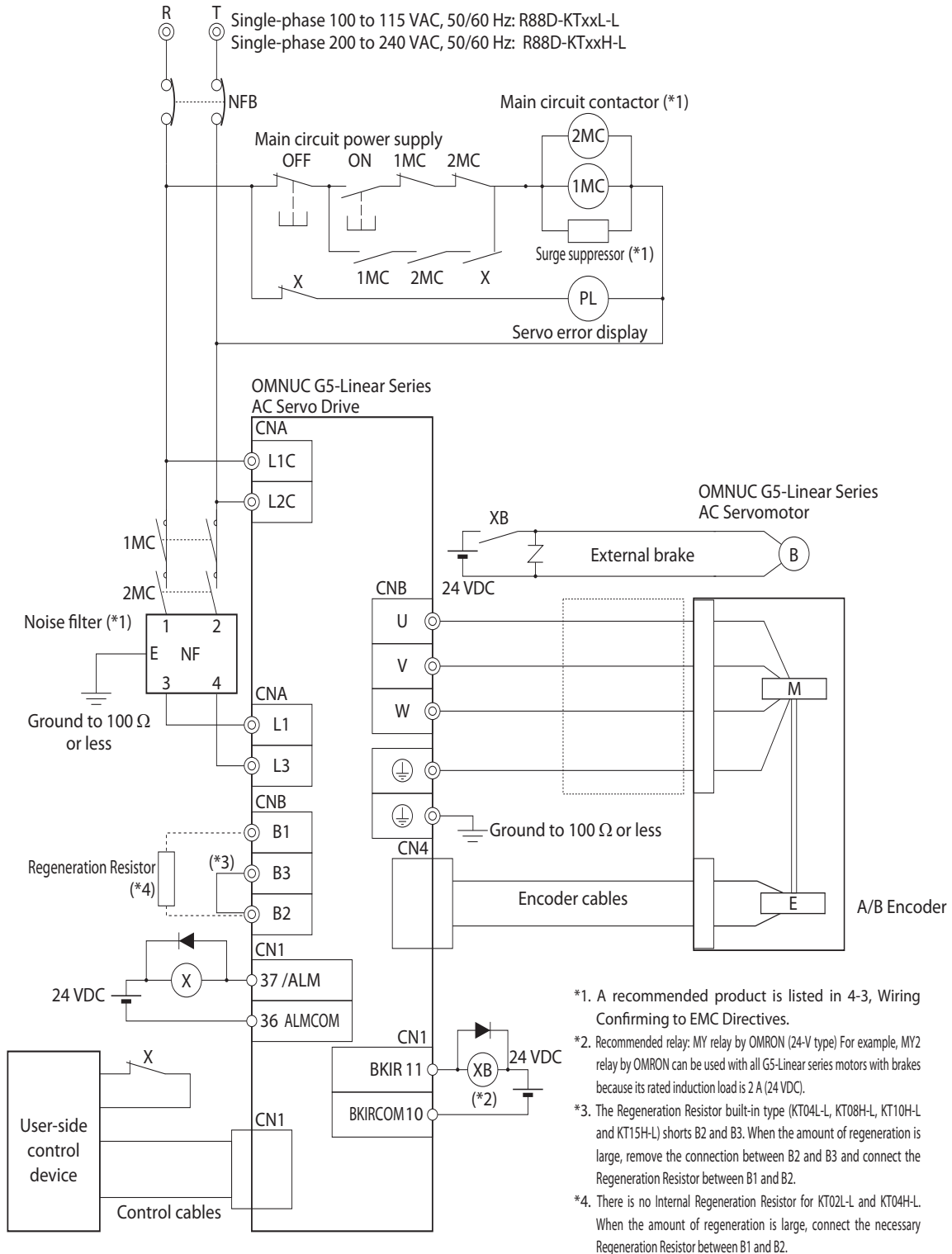

- *1. A recommended product is listed in 4-3, Wiring Confirming to EMC Directives.
- *2. Recommended relay: MY relay by OMRON (24-V type) For example, MY2 relay by OMRON can be used with all G5-Linear series motors with brakes because its rated induction load is 2 A (24 VDC).
- *3. The Regeneration Resistor built-in type (KT04L-L, KT08H-L, KT10H-L and KT15H-L) shorts B2 and B3. When the amount of regeneration is large, remove the connection between B2 and B3 and connect the Regeneration Resistor between B1 and B2.
- *4. There is no Internal Regeneration Resistor for KT02L-L and KT04H-L. When the amount of regeneration is large, connect the necessary Regeneration Resistor between B1 and B2.

4 System Design

R88D-KT02H-L/-KT04H-L/-KT08H-L/-KT10H-L/-KT15H-L (3-phase Input)

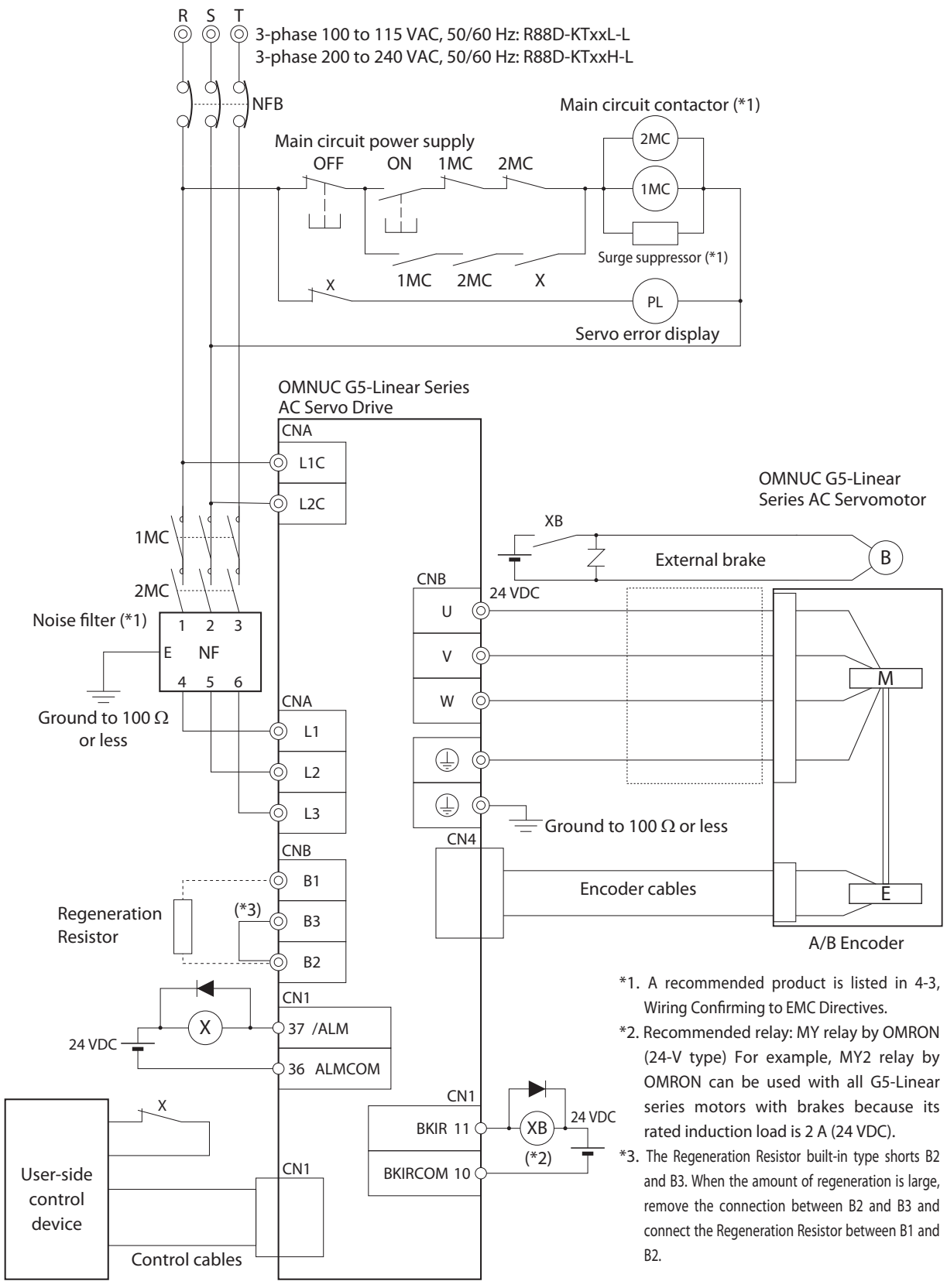

*1. A recommended product is listed in 4-3, Wiring Confirming to EMC Directives.
 *2. Recommended relay: MY relay by OMRON (24-V type) For example, MY2 relay by OMRON can be used with all G5-Linear series motors with brakes because its rated induction load is 2 A (24 VDC).
 *3. The Regeneration Resistor built-in type shorts B2 and B3. When the amount of regeneration is large, remove the connection between B2 and B3 and connect the Regeneration Resistor between B1 and B2.

R88D-KT20H-L

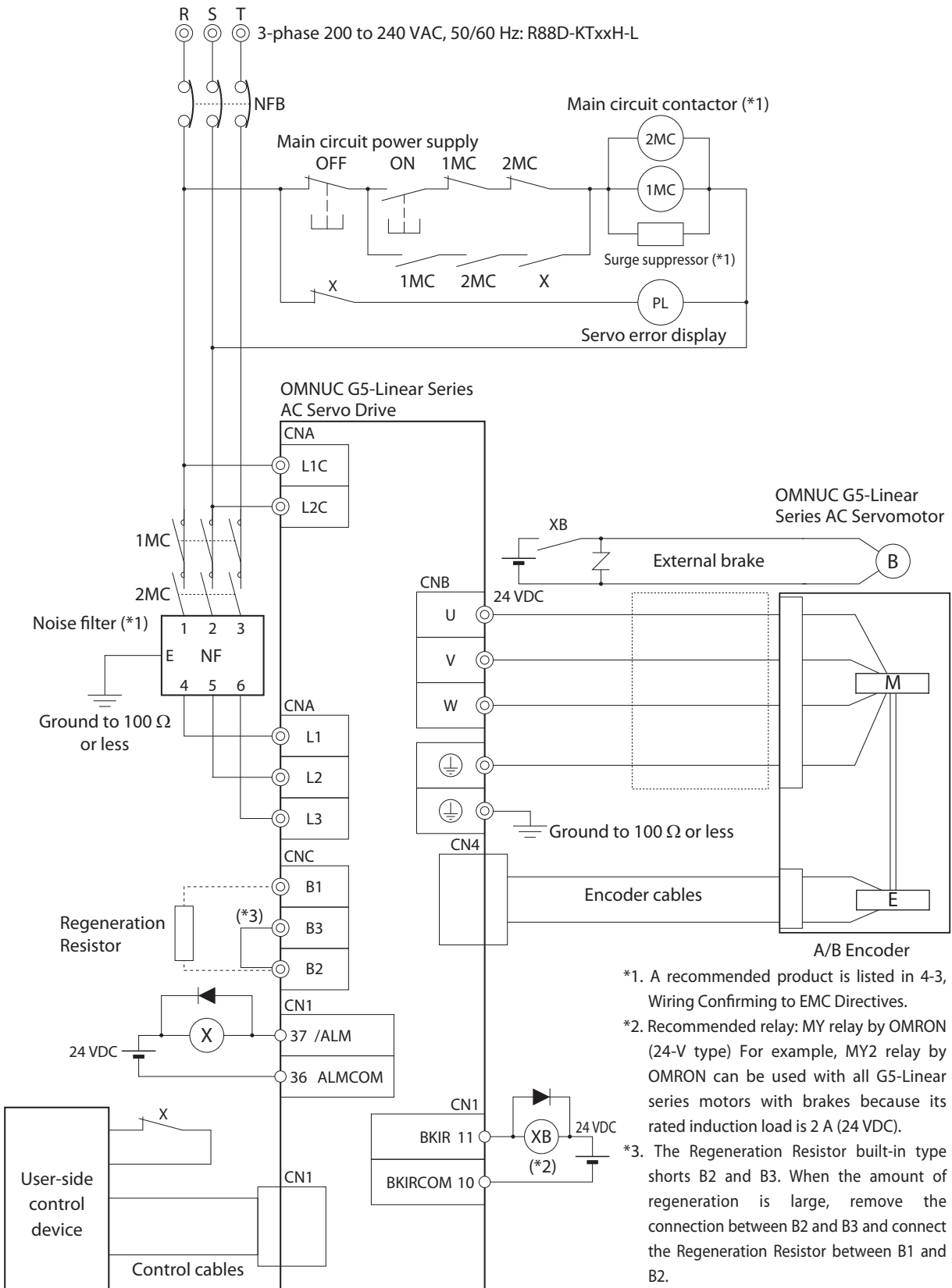

R88D-KT06F-L/-KT10F-L/-KT15F-L/-KT20F-L

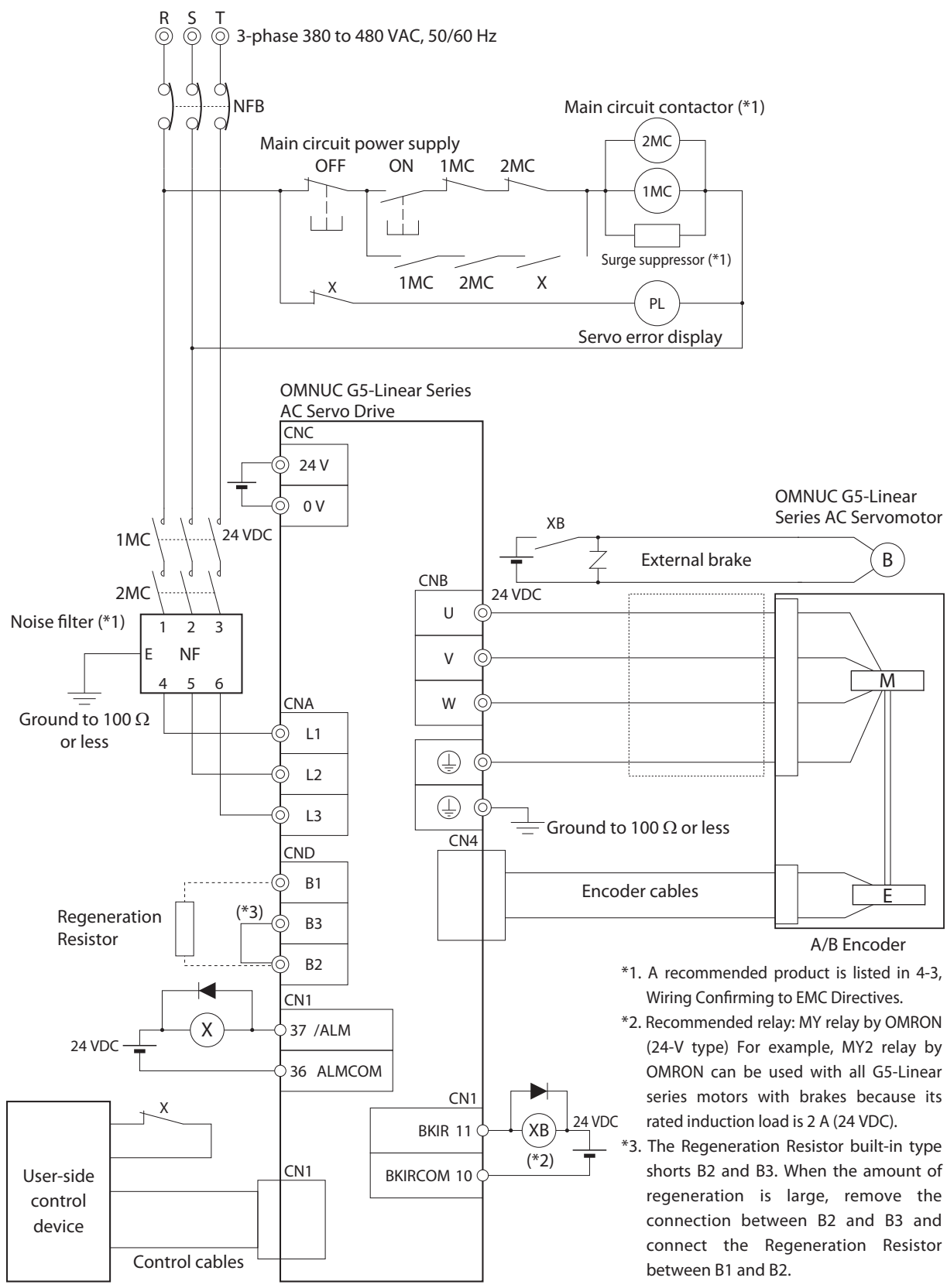

*1. A recommended product is listed in 4-3, Wiring Confirming to EMC Directives.
 *2. Recommended relay: MY relay by OMRON (24-V type) For example, MY2 relay by OMRON can be used with all G5-Linear series motors with brakes because its rated induction load is 2 A (24 VDC).
 *3. The Regeneration Resistor built-in type shorts B2 and B3. When the amount of regeneration is large, remove the connection between B2 and B3 and connect the Regeneration Resistor between B1 and B2.

R88D-KT30F-L/-KT50F-L

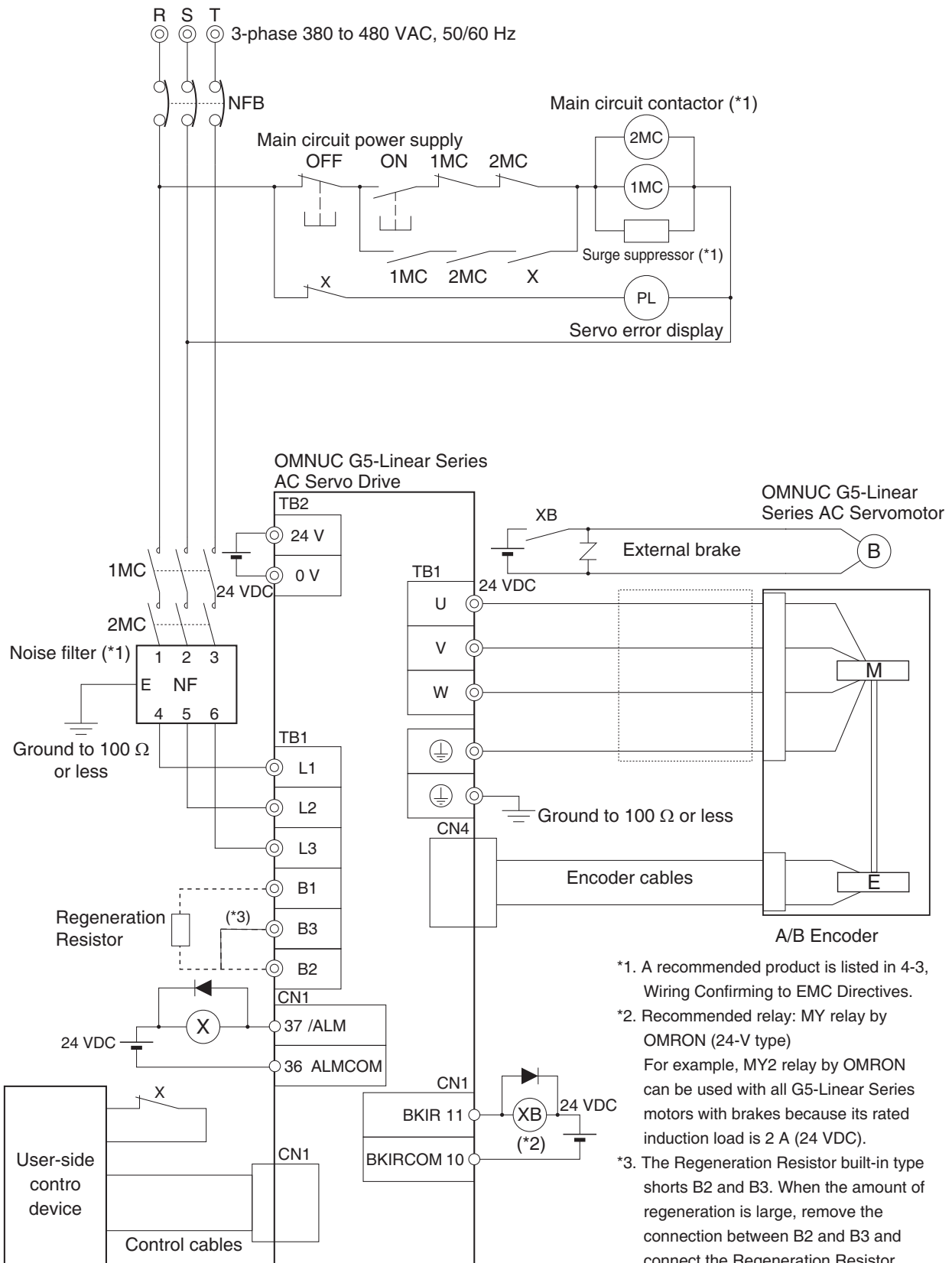

*1. A recommended product is listed in 4-3, Wiring Confirming to EMC Directives.

*2. Recommended relay: MY relay by OMRON (24-V type)
For example, MY2 relay by OMRON can be used with all G5-Linear Series motors with brakes because its rated induction load is 2 A (24 VDC).

*3. The Regeneration Resistor built-in type shorts B2 and B3. When the amount of regeneration is large, remove the connection between B2 and B3 and connect the Regeneration Resistor between B1 and B2.

Connection with SinCos Encoder

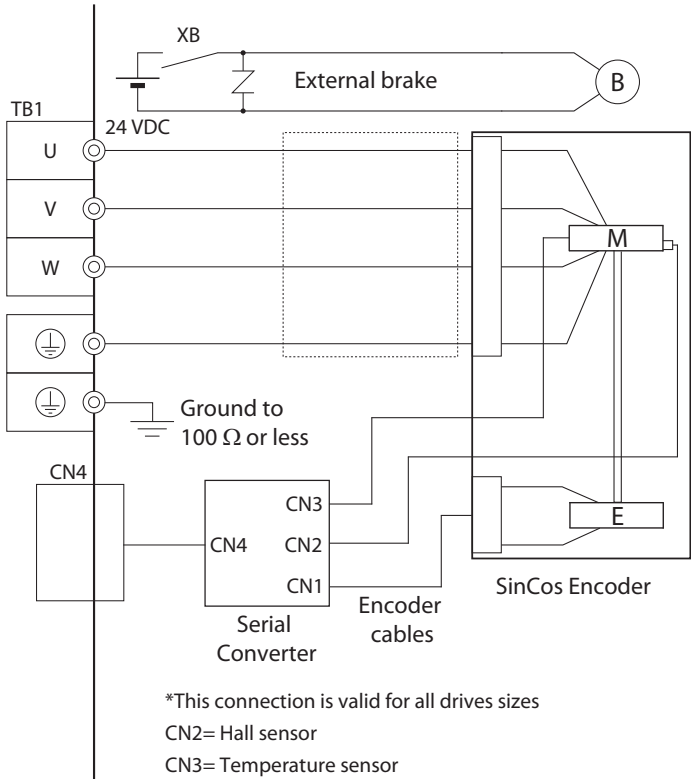

Note: Valid for all drives.

Main Circuit and Motor Connections

When wiring the main circuit, use proper wire sizes, grounding systems, and noise resistance.

**R88D/-KT01L-L/-KT02L-L/-KT04L-L
R88D-KT02H-L/-KT04H-L/-KT08H-L/-KT10H-L/-KT15H-L**

Main Circuit Connector Specifications (CNA)

Symbol	Name	Function
L1	Main circuit power supply input	R88D-KTxL-L (100 to 400 W) : Single-phase 100 to 115 VAC (85 to 127 V) 50/60 Hz R88D-KTxH-L (200 W to 1.5 kW) : Single-phase 200 to 240 VAC (170 to 264 V) 50/60 Hz (200 W to 1.5 kW): 3-phase 200 to 240 VAC (170 to 264 V) 50/60 Hz
L2		
L3		
L1C	Control circuit power supply input	R88D-KTxL-L : Single-phase 100 to 115 VAC (85 to 127 V) 50/60Hz R88D-KTxH-L : Single-phase 200 to 240 VAC (170 to 264 V) 50/60 Hz
L2C		

Motor Connector Specifications (CNB)

Symbol	Name	Function
B1	External Regeneration Resistor connection terminals	50 to 400 W: These terminals normally do not need to be connected. If there is high regenerative energy, connect an External Regeneration Resistor between B1 and B2. 750 W to 1.5 kW: Normally B2 and B3 are shorted. If there is high regenerative energy, remove the short-circuit bar between B2 and B3 and connect an External Regeneration Resistor between B1 and B2.
B2		
B3		
U	Motor connection terminals	These are the output terminals to the Linear Servomotor. Be sure to wire them correctly.
V		
W		
⊕		
⊕	Frame ground	This is the ground terminal. Ground to 100 Ω or less.

R88D-KT20H-L

Main Circuit Connector Specifications (CNA)

Symbol	Name	Function
L1	Main circuit power supply input	R88D-KTxH-L (2 kW) : 3-phase: 200 to 230 VAC (170 to 253 V) 50/60 Hz
L2		
L3		
L1C	Control circuit power supply input	R88D-KTxH-L : Single-phase 200 to 230 VAC (170 to 253 V) 50/60 Hz
L2C		

Motor Connector Specifications (CNB)

Symbol	Name	Function	
U	Motor connection terminals	Red	These are the output terminals to the Linear Servomotor. Be sure to wire them correctly.
V		White	
W		Blue	
⊕		Green/ Yellow	
⊕	Frame ground	This is the ground terminal. Ground to 100 Ω or less.	

External Regeneration Resistor Connector Specifications (CNC)

Symbol	Name	Function
B1	External Regeneration Resistor connection terminals	Normally B2 and B3 are short-circuited. If there is high regenerative energy, remove the short-circuit bar between B2 and B3 and connect an External Regeneration Resistor between B1 and B2.
B2		
B3		

R88D-KT06F-L/-KT10F-L/-KT15F-L/-KT20F-L**Main Circuit Connector Specifications (CNA)**

Symbol	Name	Function
L1	Main circuit power supply input	R88D-KTxF-L (600 W to 2 kW) : 3-phase: 380 to 480 VAC (323 to 528 V) 50/60 Hz
L2		
L3		

Motor Connector Specifications (CNB)

Symbol	Name	Function
U	Motor connection terminals	Red
V		White
W		Blue
⊕		Green/ Yellow
⊕	Frame ground	This is the ground terminal. Ground to 100 Ω or less.

Control Circuit Connector Specifications (CNC)

Symbol	Name	Function
24 V	Control circuit power supply input	24 VDC (21.6 to 26.4 V)
0 V		

External Regeneration Resistor Connector Specifications (CND)

Symbol	Name	Function
B1	External Regeneration Resistor connection terminals	Normally B2 and B3 are short-circuited.
B2		If there is high regenerative energy, remove the short-circuit bar between B2 and B3 and connect an External Regeneration Resistor between B1 and B2.
B3		

R88D-KT30F-L/-KT50F-L

Terminal Block Specifications (TB1)

Symbol	Name	Function
L1	Main circuit power supply input	R88D-KTxF-L (3 to 5 kW): 3-phase 380 to 480 VAC (323 to 528 V) 50/60 Hz
L2		
L3		
B1	External Regeneration Resistor connection terminals	Normally B2 and B3 are short-circuited. If there is high regenerative energy, remove the short-circuit bar between B2 and B3 and connect an External Regeneration Resistor between B1 and B2.
B2		
B3		
U	Motor connection terminals	Red
V		White
W		Blue
⊕		Green/ Yellow
⊕	Frame ground	This is the ground terminal. Ground to 100 Ω or less.
N	–	Do not connect.
24 V	Control circuit power supply input	R88D-KTxF-L: 24 VDC (21.6 to 26.4 V)
0 V		
⊕	Frame ground	This is the ground terminal. Ground to 100 Ω or less.
NC	–	Do not connect.

Terminal Block Wire Sizes

100-VAC Input Type Wire Sizes: R88D-KTxxL-L

Model (R88D-)			KT01L-L	KT02L-L	KT04L-L
Item	Unit				
Power supply capacity	kVA		0.4	0.5	0.9
Main circuit power supply input (L1 and L3, or L1, L2 and L3) *1	Rated current	A	2.6	4.3	7.6
	Wire size	–	AWG14 to 18		
Control circuit power supply input (L1C and L2C)	Wire size	–	AWG18		
Motor connection terminals (U, V, W, and FG) *2	Rated current	A	1.7	2.5	4.6
	Wire size	–	AWG14 to 18		
Frame ground (FG)	Wire size	–	AWG14		
	Screw size	–	M4		
	Tightening force	N·m	1.2		

200 VAC Input Type Wire Sizes: R88D-KTxxH-L

Model (R88D-)			KT02H-L	KT04H-L	KT08H-L	KT10H-L
Item	Unit					
Power supply capacity	kVA		0.5	0.9	1.3	1.8
Main circuit power supply input (L1 and L3, or L1, L2 and L3) *1	Rated current	A	2.4/1.3 *1	4.1/2.4 *1	6.6/3.6 *1	9.1/5.9 *1
	Wire size	–	AWG14 to 18			AWG14
	Screw size	–	–	–	–	–
	Tightening force	N·m	–	–	–	–
Control circuit power supply input (L1C and L2C)	Wire size	–	AWG18			
	Screw size	–	–	–	–	–
	Tightening force	N·m	–	–	–	–
Motor connection terminals (U, V, W, and FG) *2	Rated current	A	1.6	2.6	4.1	5.9
	Wire size	–	AWG14 to 18			AWG14
	Screw size	–	–	–	–	–
	Tightening force	N·m	–	–	–	–
Frame ground (FG)	Wire size	–	AWG14			
	Screw size	–	M4			
	Tightening force	N·m	1.2			

Model (R88D-)			KT15H-L	KT20H-L
Item	Unit			
Power supply capacity	kVA		2.3	3.3
Main circuit power supply input (L1 and L3, or L1, L2 and L3)	Rated current	A	14.2/8.1*1	11.8
	Wire size	–	AWG14	
	Screw size	–	–	–
	Tightening force	N·m	–	–
Control circuit power supply input (L1C and L2C)	Wire size	–	AWG18	
	Screw size	–	–	–
	Tightening force	N·m	–	–
Motor connection terminals (U, V, W, and FG) *1	Rated current	A	9.4	13.4
	Wire size	–	AWG14	
	Screw size	–	–	–
	Tightening force	N·m	–	–
Frame ground (FG)	Wire size	–	AWG14	
	Screw size	–	M4	
	Tightening force	N·m	1.2	

*1. Use the same wire sizes for B1 and B2.

Note 1. The left value is for single-phase input and the right value is for 3-phase input.

Note 2. Connect an OMRON power cable to the motor connection terminals.

400 VAC Input Type Wire Sizes: R88D-KTxxF-L

Model (R88D-)			KT06F-L	KT10F-L	KT15F-L	KT20F-L	KT30F-L	KT50F-L
Item	Unit							
Main circuit power supply input (L1 and L3, or L1, L2 and L3)	Rated current	A	28	2.8	3.9	5.9	7.6	12.1
	Wire size	–	AWG14				AWG12	
	Screw size	–	–	–	–	–	M5	
	Tightening force	N·m	–	–	–	–	2.0	
Control circuit power supply input (L1C and L2C)	Wire size	–	AWG20 to 24				AWG18	
	Screw size	–	–	–	–	–	M5	
	Tightening force	N·m	–	–	–	–	2.0	
Motor connection terminals (U, V, W, and FG) *1	Rated current	A	2.9	2.9	4.7	6.7	9.4	16.5
	Wire size	–	AWG14				AWG12	
	Screw size	–	–	–	–	–	M5	
	Tightening force	N·m	–	–	–	–	2.0	
Frame ground (FG)	Wire size	–	AWG14				AWG12	
	Screw size	–	M4				M5	
	Tightening force	N·m	1.2				2.0	

*1. Use the same wire sizes for B1 and B2.

Note 1. The left value is for single-phase input and the right value is for 3-phase input.

Note 2. Connect an OMRON power cable to the motor connection terminals.

Wire Sizes and Allowable Current (Reference)

The following table shows the allowable current when there are 3 power supply wires. Use a current below these specified values.

600-V Heat-resistant Vinyl Wire (HIV)

AWG size	Nominal cross-sectional area (mm ²)	Configuration (wires/mm ²)	Conductive resistance (Ω/km)	Allowable current (A) for ambient temperature		
				30°C	40°C	50°C
20	0.5	19/0.18	39.5	6.6	5.6	4.5
–	0.75	30/0.18	26.0	8.8	7.0	5.5
18	0.9	37/0.18	24.4	9.0	7.7	6.0
16	1.25	50/0.18	15.6	12.0	11.0	8.5
14	2.0	7/0.6	9.53	23	20	16
12	3.5	7/0.8	5.41	33	29	24
10	5.5	7/1.0	3.47	43	38	31
8	8.0	7/1.2	2.41	55	49	40
6	14.0	7/1.6	1.35	79	70	57

Terminal Block Wiring Procedure

On a drive with 2.0 kW or less, a connector-type terminal block is used. The procedure for wiring these terminal blocks is explained below.

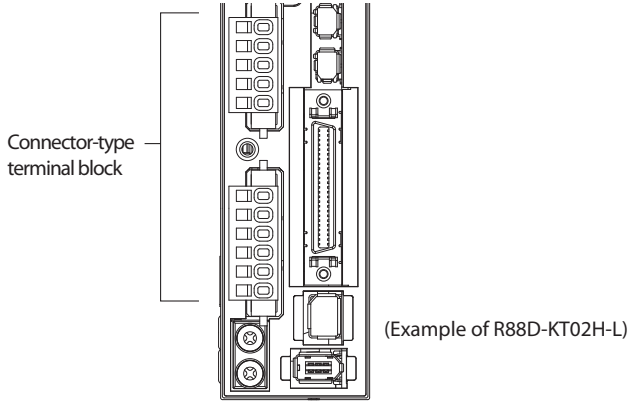

1. **Remove the terminal block from the drive before wiring.**
The drive will be damaged if the wiring is done with the terminal block in place.
2. **Strip off 8 to 9 mm of the covering from the end of each wire.**
Refer to "Terminal Block Wire Sizes" (P.4-25) for applicable wire sizes.

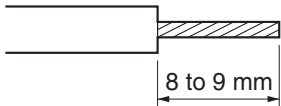

3. **Open the wire insertion slots in the terminal block using a tool.**
There are 2 ways to open the wire insertion slots, as follows.
 - Pry the slot open using the lever that comes with the Linear Servo Drive. (Figure A)
 - Insert a flat-blade screwdriver (end width: 3.0 to 3.5 mm) into the opening for the drive of the terminal block, and press down firmly to open the slot. (Figure B)

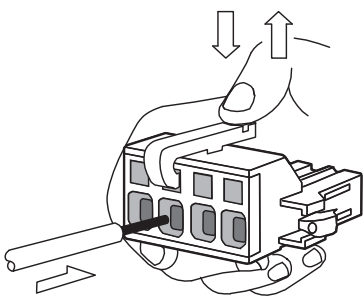

Figure A

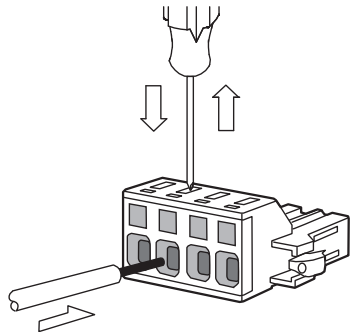

Figure B

4. **With the wire insertion slot held open, insert the end of the wire.**
After inserting the wire, let the slot close by releasing the pressure from the lever or the screwdriver.
5. **Mount the terminal block to the drive.**
After all of the terminals have been wired, return the terminal block to its original position on the Linear Servo Drive.

4-3 Wiring Conforming to EMC Directives

Conformance to the EMC directives (EN55011 Class A Group 1 (EMI) and EN61000-6-2 (EMS)) can be ensured by wiring under the conditions described in this section.

These conditions are for conformance of Accurax G5-Linear products to the EMC directives. EMC-related performance of these products, however, may be influenced by the configuration, wiring, and other conditions of the equipment in which the products are installed. The EMC conformance of the system as a whole must be confirmed by the customer.

The following are the requirements for EMC directive conformance.

- ♦ The drive must be installed in a metal case (control panel). (The motor does not, however, have to be covered with a metal plate.)
- ♦ Noise filters and lightning surge absorptive elements (surge absorbers) must be installed on power supply lines.
- ♦ Braided shielded cables must be used for all I/O signal cables and encoder cables. (Use tin-plated, mild steel wires for the shielding.)
- ♦ All cables, I/O wiring, and power lines connected to the drive may have clamp filters installed to improve the noise immunity.
- ♦ The shields of all cables must be directly connected to a ground plate.

4

Wiring Method

R88D-KT01L-L/-KT02L-L/-KT04L-L/-KT02H-L/-KT04H-L/-KT08H-L/-KT10H-L/-KT15H-L/-KT20H-L

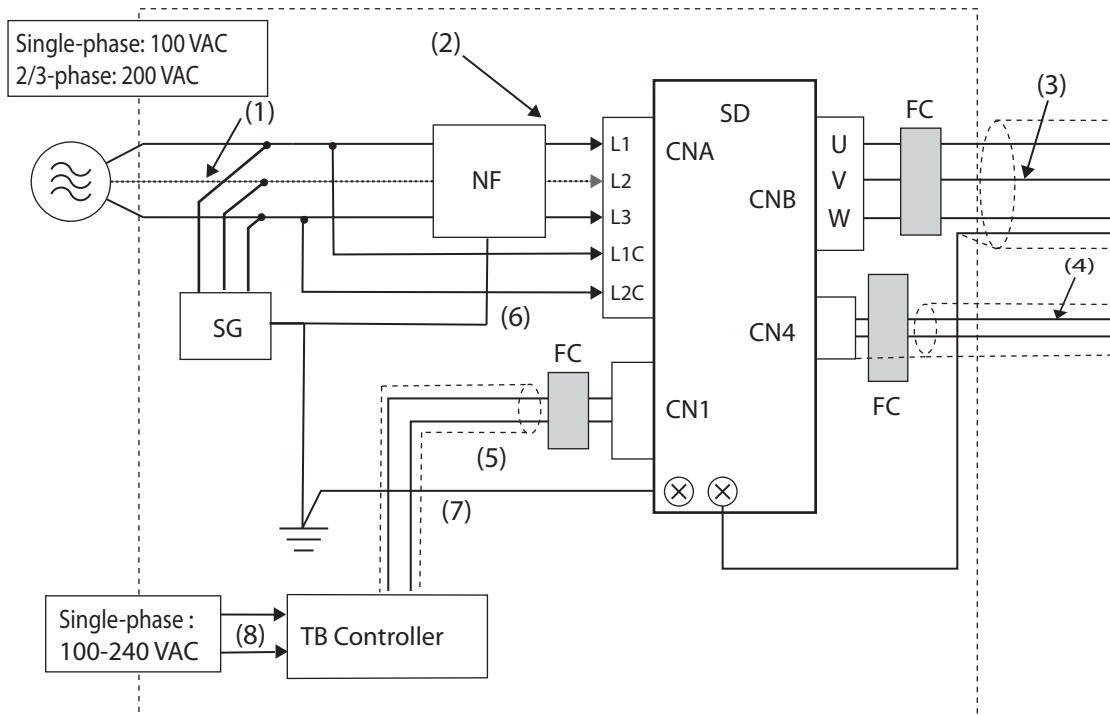

*1. For models with a single-phase power supply input (R88D-KT01L-L/-KT02L-L/-KT04L-L/-KT02H-L/-KT04H-L/-KT08H-L/-KT10H-L/-KT15H-L), the main circuit power supply input terminals are L1 and L3.

- ♦ Ground the motor's frame to the machine ground when the motor is on a movable shaft.
- ♦ Use a ground plate for the frame ground for each unit, as shown in the above diagrams, and ground to a single point.
- ♦ Use ground lines with a minimum thickness of 3.5 mm^2 , and arrange the wiring so that the ground lines are as short as possible.
- ♦ No-fuse breaker, surge absorber, and noise filter should be positioned near the input terminal block (ground plate), and I/O lines should be separated and wired at the shortest distance.

R88D-KR06F-L/-KT10F-L/-KT15F-L/-KT20F-L/-KT30F-L/-KT50F-L

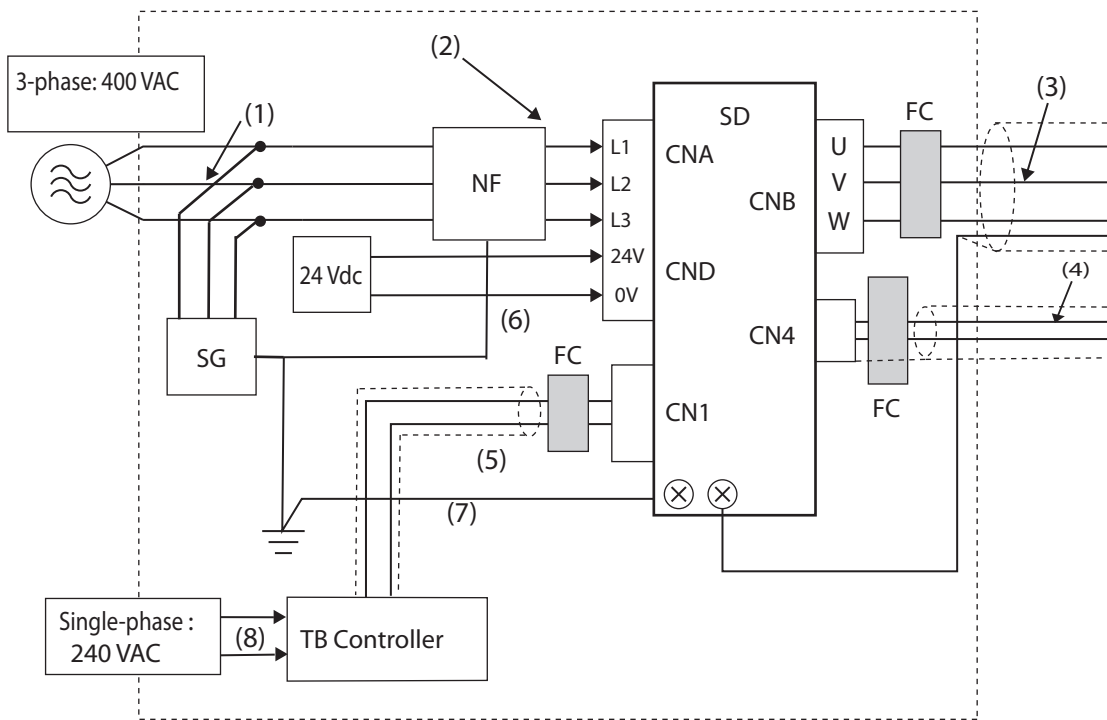

Unit Details

Symbol	Name	Manufacturer	Model	Comment
SG	Surge absorber (Optional)	Okaya Electric Industries Co., Ltd.	RAV781BWZ-4	Single-phase 100 VAC
			RAV781BXZ-4	3-phase 200 VAC
NF	Noise filter	Rasmi	R88A-FIK102-RE	250 VAC single-phase
			R88A-FIK104-RE	250 VAC single-phase
			R88A-FIK107-RE	250 VAC single-phase
			R88A-FIK114-RE	250 VAC single-phase
			R88A-FIK304-RE	400 VAC single-phase
			R88A-FIK306-RE	400 VAC single-phase
			R88A-FIK312-RE	400 VAC single-phase
SD	Linear Servo Drive	OMRON	-	*1
SM	Linear Servomotor	OMRON	-	*1
FC	Clamp core	TDK	ZACT305-1330	-
TB	Controller	-	-	Switch box

*1. A specified combination of Linear Servo Drive and Servomotor must be used.

4-3 Wiring Conforming to EMC Directives

Ground the shields using a high-surface connection to the ground plate like in the figure.

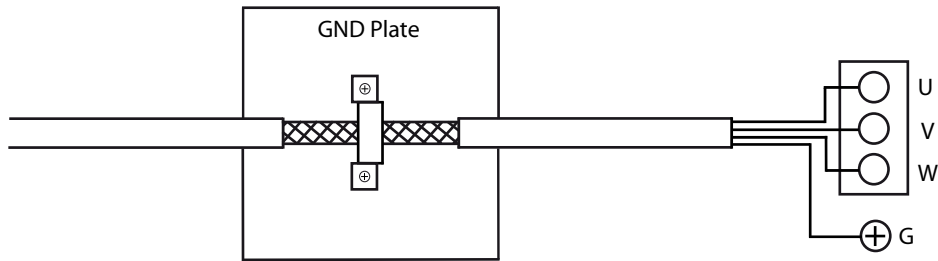

Cable Details

Symbol	Supplies from	Connects to	Cable name	Length	Comment	Shielded	Ferrite
(1)	AC power supply	Noise filter	Power supply line	2 m	3-phase or single phase	No	No
(2)	Noise filter	Servo Drive	Power supply line	2 m	–	No	Optional
(3)	Linear Servo Drive	Linear Servomotor	Power cable	20 m	–	Yes	Optional
(4)	Linear Servo Drive	Linear Servomotor	Encoder cable	20 m	–	Yes	Optional
(5)	Switch box	Linear Servo Drive	I/O cable	2 m	–	Optional	Optional
(6)	Frame ground	Noise filter	FG line	1.5 m	–	No	No
(7)	Frame ground	Noise filter	FG line	1.5 m	–	No	No
(8)	AC power supply	Switch box	Power supply line	1.5 m	–	No	No

- ♦ For operations, if no-fuse breakers are installed at the top and the power supply line is wired from the lower duct, use metal tubes for wiring or make sure that there is adequate distance between the input lines and the internal wiring. If input and output lines are wired together, noise resistance will decrease.
- ♦ The noise filter must be installed as close as possible to the entrance of the control panel. Wire as shown at the left in the following illustration.

○ Separate the input and output.

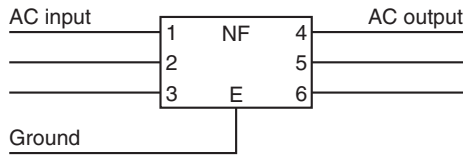

✗ The effect of the noise filter is small.

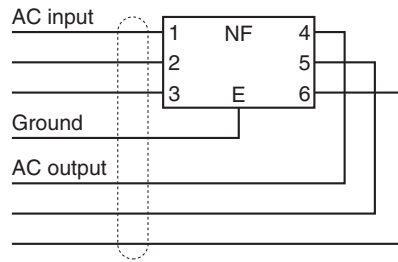

◆ Use twisted-pair cables for the power supply cables, or bind the cables.

○ Twisted-pair process

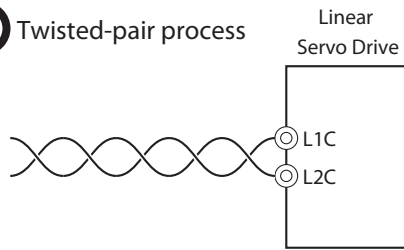

○ Bound cables

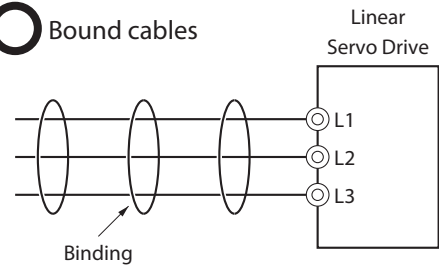

◆ Separate power supply lines and signal lines when wiring.

Control Panel Structure

Openings in the control panel, such as holes for cables, operating panel mounting holes, and gaps around the door, may allow electromagnetic waves into the panel. To prevent this, observe the recommendations described below when designing or selecting a control panel.

Case Structure

- ♦ Use a metal control panel with welded joints at the top, bottom, and sides so that the surfaces will be electrically conductive.
- ♦ If assembly is required, strip the paint off the joint areas (or mask them during painting), to make them electrically conductive.
- ♦ The panel may warp and gaps may appear when screws are tightened. Be sure that no gaps appear when tightening screws.
- ♦ Do not leave any conductive part unconnected.
- ♦ Ground all units within the case to the case itself.

Door Structure

- ♦ Use a metal door.
- ♦ Use a water-draining structure where the door and case fit together, and leave no gaps. (Refer to the diagrams.)
- ♦ Use a conductive gasket between the door and the case. (Refer to the diagrams.)
- ♦ Strip the paint off the sections of the door and case that will be in contact with the conductive gasket (or mask them during painting), so that they will be electrically conductive.
- ♦ The panel may warp and gaps may appear when screws are tightened. Be sure that no gaps appear when tightening screws.

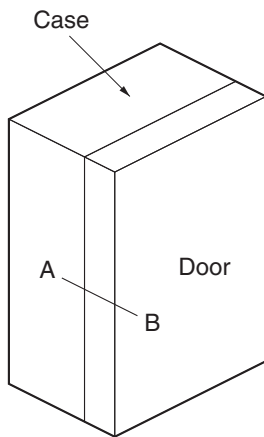

[Control panel]

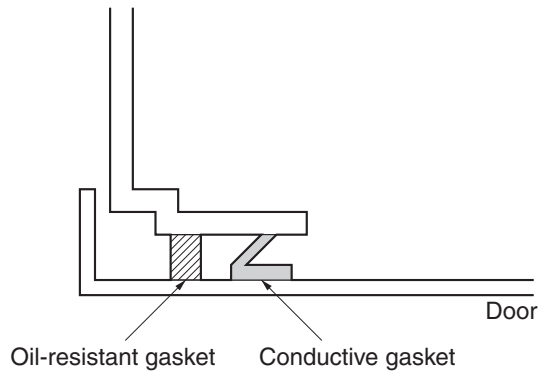

[A-B cross-section diagram]

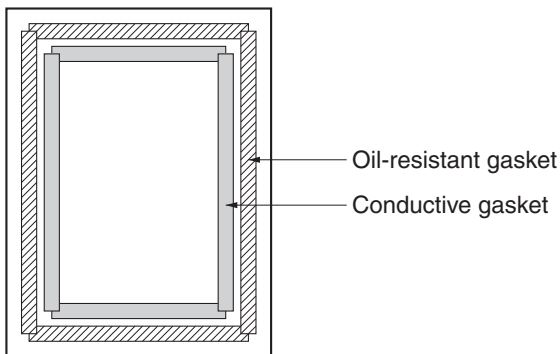

[Door (interior side)]

Selecting Connection Component

This section explains the criteria for selecting the connection components required to improve noise resistance. Understand each component's characteristics, such as its capacity, performance, and applicable range when selecting the connection components.

For more details, contact the manufacturers directly.

No-fuse Breaker (NFB)

When selecting a no-fuse breaker, consider the maximum input current and the inrush current.

Maximum Input Current

- ♦ The drive's momentary maximum output is approx. 3 times the rated output, and can be output for up to 3 seconds.
Therefore, select no-fuse breakers with an operation time of at least 5 seconds at 300% of the rated current ratio. General and low-speed no-fuse breakers are generally suitable.
- ♦ Select a no-fuse breaker with a rated current greater than the total effective load current of all the motors (when multiple drives are used). (The rated current of the power supply input for each motor is provided in "Main Circuit and Motor Connections"(P.4-22).)
- ♦ Add the current consumption of other controllers, and any other components when selecting.

Inrush Current

- ♦ The following table lists the drive inrush currents.
- ♦ With low-speed no-fuse breakers, an inrush current 10 times the rated current can flow for 0.02 second.
- ♦ When multiple drives are turned ON simultaneously, select a no-fuse breaker with a 20-ms allowable current that is greater than the total inrush current, shown in the following table.

Drive model	Inrush current (Ao-p)	
	Main circuit power supply	Control circuit power supply
R88D-KT01L-L	7	14
R88D-KT02L-L	7	14
R88D-KT04L-L	15	14
R88D-KT02H-L	14	28
R88D-KT04H-L	14	28
R88D-KT08H-L	29	28
R88D-KT10H-L	29	28
R88D-KT15H-L	29	28
R88D-KT20H-L	29	14

Drive model	Inrush current (Ao-p)	
	Main circuit power supply	Control circuit power supply
R88D-KT06F-L	28	48
R88D-KT10F-L	28	48
R88D-KT15F-L	28	48
R88D-KT20F-L	32	48
R88D-KT30F-L	32	48
R88D-KT50F-L	32	48

Leakage Breaker

- ♦ Select leakage breakers designed for protection against ground faults.
- ♦ Because switching takes place inside the drives, high-frequency current leaks from the SW elements of the drive, the armature of the motor, and the cables.
High-frequency, surge-resistant leakage breakers, because they do not detect high-frequency current, can prevent operation with high-frequency leakage current.
When using a general leakage breaker, use 3 times the total of the leakage current given in the following table as a reference value.
- ♦ When selecting leakage breakers, remember to add the leakage current from devices other than the motor, such as machines using a switching power supply, noise filters, inverters, and so on.
To prevent malfunction due to inrush current, we recommend using a leakage breaker of 10 times the total of all current values.
- ♦ The leakage breaker is activated at 50% of the rated current. Allow leeway when selecting a leakage breaker.
- ♦ For details on leakage breakers selection method, refer to the manufacturer's catalog.

Surge Absorber

- Use surge absorbers to absorb lightning surge voltage and abnormal voltage from power supply input lines.
- When selecting surge absorbers, take into account the varistor voltage, the surge immunity and the energy tolerated dose.
- For 200-VAC systems, use surge absorbers with a varistor voltage of 620 V.
- The surge absorbers shown in the following table are recommended.

Manufacturer	Model	Surge immunity		Type	Comment
Okaya Electric Industries Co., Ltd.	RAV-781BWZ-4	700 V ± 20%	2500 A	Block	Single-phase 100/200 VAC
Okaya Electric Industries Co., Ltd.	RAV-781BXZ-4	700 V ± 20%	2500 A		3-phase 200 VAC

Note 1. Refer to the manufacturers' catalog for operating details.

Note 2. The surge immunity is for a standard impulse current of 8/20 μs. If pulses are wide, either decrease the current or change to a larger-capacity surge absorber.

External Dimensions

For single-phase (BWZ series)

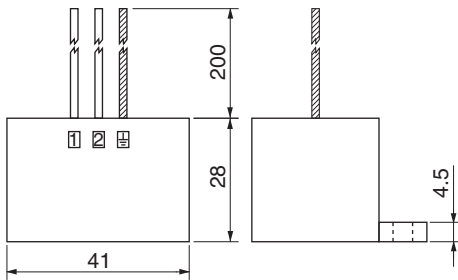
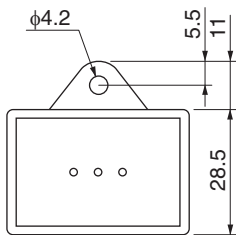

For 3-phase (BXZ series)

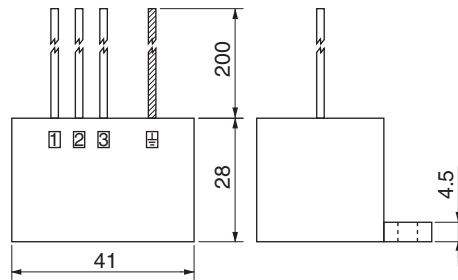
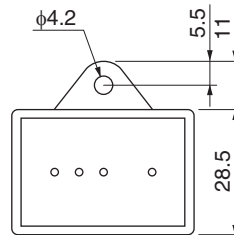

Equalizing Circuits

For single-phase (BWZ series) For 3-phase (BXZ series)

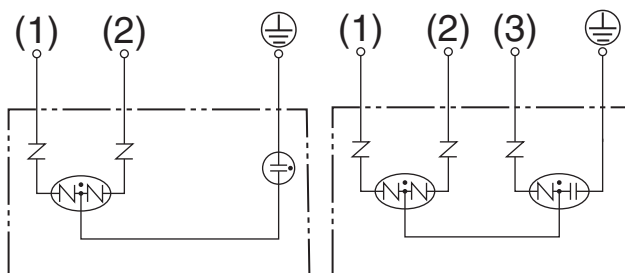

Noise Filter for the Brake Power Supply

- ◆ In case you use external electrical brakes, use a suitable noise filter for the Brake power supply.
Note. Noise can also be reduced by installing a Radio Noise Filter.

Radio Noise Filter and Emission Noise Prevention Clamp Core

Use one of the following filters to prevent switching noise of PWM of the Linear Servo Drive and to prevent noise emitted from the internal clock circuit.

Model	Manufacturer	Application
3G3AX-ZCL1 *1	OMRON	Drive output and power cable
3G3AX-ZCL2 *2	OMRON	Drive output and power cable
ESD-R-47B *3	NEC TOKIN	Drive output and power cable
ZCAT3035-1330 *4	TDK	Encoder cable and I/O cable

*1. Generally used for 1.5 kW or higher.

*2. Generally used for 1.5 kW or lower. The maximum number of windings is 3 turns.

*3. Generally used for 100 W. The maximum number of windings is 2 turns.

*4. Also used on the drive output power lines to comply with the EMC directives. Only a clamp is used.
This clamp can also be used to reduce noise current on a FG line.

External Dimensions

3G3AX-ZCL1

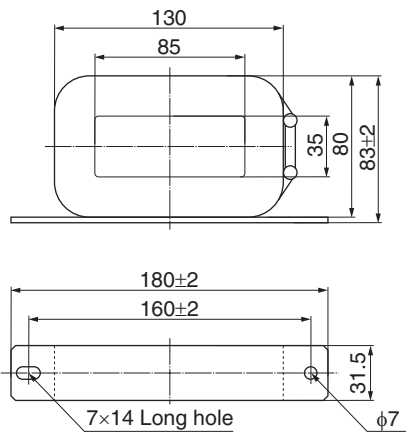

3G3AX-ZCL2

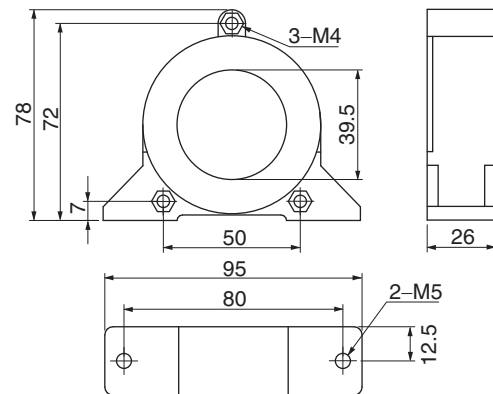

ESD-R-47B

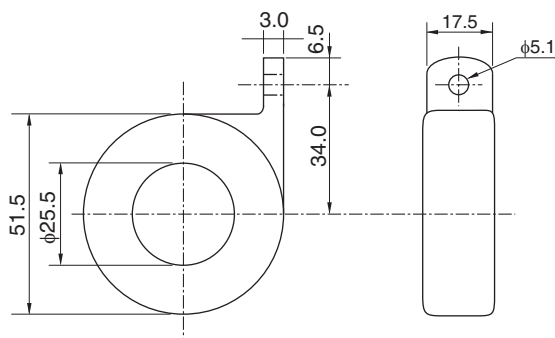

ZCAT3035-1330

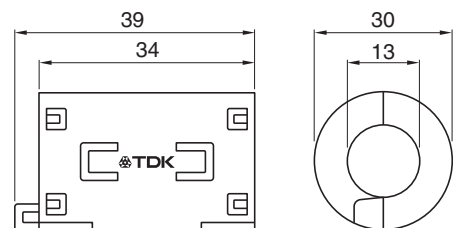

Impedance Characteristics

3G3AX-ZCL1

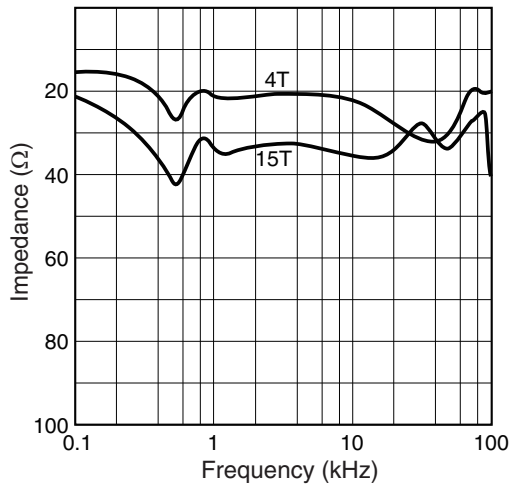

3G3AX-ZCL2

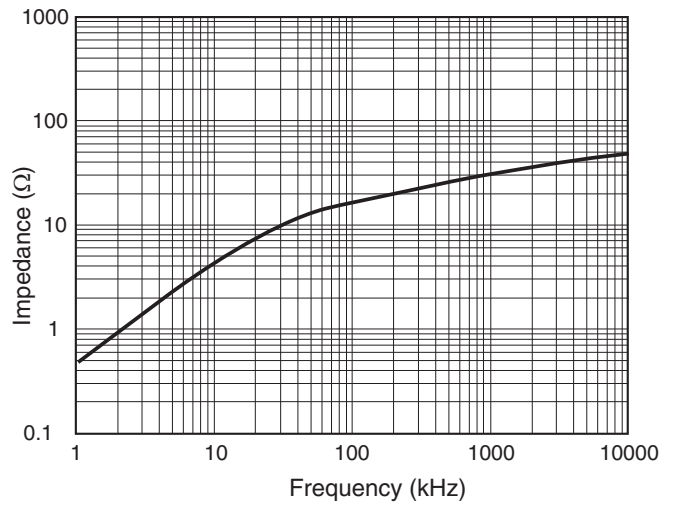

ESD-R-47B

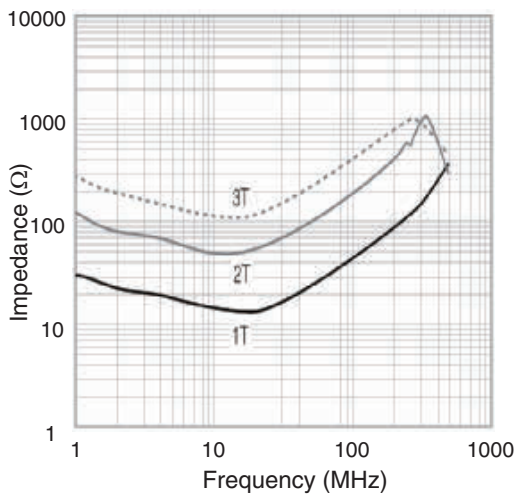

ZCAT3035-1330

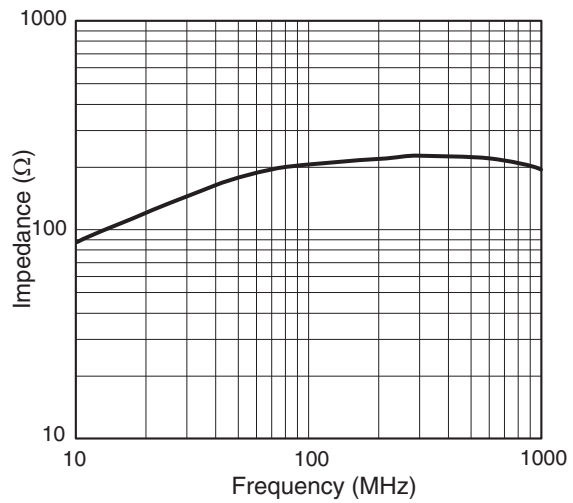

Surge Suppressor

- ♦ Install surge suppressors for loads that have induction coils, such as relays, solenoids, brakes, clutches, etc.
- ♦ The following table shows the types of surge suppressors and recommended products.

Type	Feature	Recommended product
Diodes	Diodes are used for relatively small loads when the reset time is not an issue, such as relays. At power shutoff the surge voltage is the lowest, but the rest time takes longer. Used for 24/48-VDC systems.	Use a fast-recovery diode with a short reverse recovery time (e.g. RU2 of Sanken Electric Co., Ltd.).
Thyristors and varistors	Thyristors and varistors are used for loads when induction coils are large, as in electromagnetic brakes, solenoids, etc., and when reset time is an issue. The surge voltage at power shutoff is approx. 1.5 times the varistor voltage.	Select the varistor voltage as follows. For 24-VDC systems, varistor voltage 39 V For 100-VDC systems, varistor voltage 200 V For 100-VAC systems, varistor voltage 270 V For 200-VAC systems, varistor voltage 470 V
Capacitor + resistor	The capacitor plus resistor combination is used to absorb vibration in the surge at power supply shutoff. The reset time can be shortened by selecting the appropriate capacitance and resistance.	Okaya Electric Industries Co., Ltd. XEB12002 0.2 μ F-120 Ω XEB12003 0.3 μ F-120 Ω

- ♦ Thyristors and varistors are made by the following manufacturers. Refer to manufacturer's documentation for details on these components.

Thyristors: Ishizuka Electronics Co.

Varistor: Ishizuka Electronics Co., Panasonic Corporation

Contactors

- ♦ Select contactors based on the circuit's inrush current and the maximum momentary phase current.
- ♦ The drive inrush current is covered in the preceding explanation of no-fuse breaker selection.
And the maximum momentary phase current is approx. twice the rated current.
- ♦ The following table shows the recommended contactors.

Manufacturer	Model	Rated current	Coil voltage
OMRON	J7L-09-22200	11 A	200 VAC
	J7L-12-22200	13 A	200 VAC
	J7L-18-22200	18 A	200 VAC
	J7L-32-22200	26 A	200 VAC
	J7L-40-22200	35 A	200 VAC
	J7L-50-22200	50 A	200 VAC
	J7L-65-22200	65 A	200 VAC
	J7L-75-22200	75 A	200 VAC

Improving Encoder Cable Noise Resistance

Take the following steps during wiring and installation to improve the encoder's noise resistance.

- Always use the specified encoder cables.
- If cables are joined midway, be sure to use connectors. And do not remove more than 50 mm of the cable insulation. In addition, always use shielded cables.
- Do not coil cables. If cables are long and are coiled, mutual induction and inductance will increase and cause malfunctions. Always use cables fully extended.
- When installing noise filters for encoder cables, use clamp filters.
- The following table shows the recommended clamp filters.

Manufacturer	Product name	Model	Specifications
NEC TOKIN	Clamp filters	ESD-SR-250	For cable dia. up to 13 mm
TDK	Clamp filters	ZCAT3035-1330	For cable dia. up to 13 mm

- Do not place the encoder cable with the following cables in the same duct.
Control cables for brakes, solenoids, clutches, and valves.

External Dimensions

ESD-SR-250

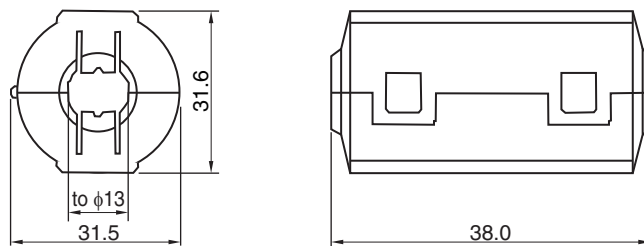

Impedance Characteristics

ESD-SR-250

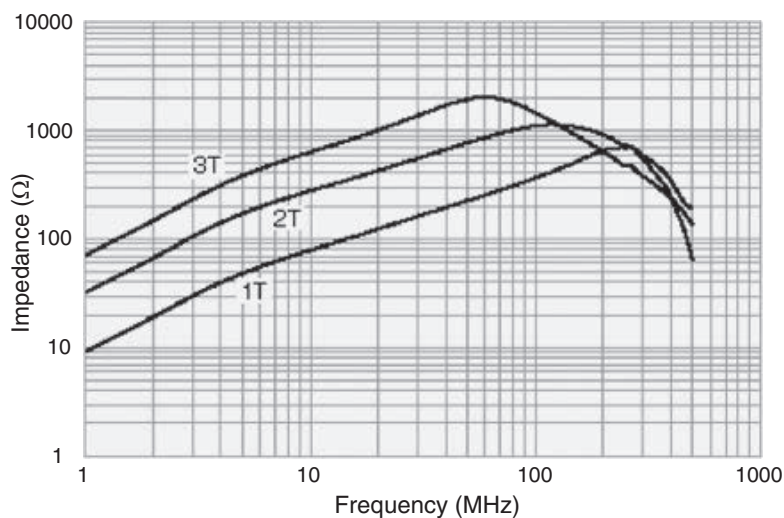

Improving Control I/O Signal Noise Resistance

Positioning can be affected and I/O signal errors can occur if control I/O is influenced by noise.

- ♦ Use completely separate power supplies for the control power supply (especially 24 VDC) and the external operation power supply. In particular, do not connect the 2 power supply ground wires.
- ♦ Install a noise filter on the primary side of the control power supply.
- ♦ If 24V DC supply brakes are being used, do not use the same 24-VDC power supply for both the brakes and the control I/O. Additionally, do not connect the ground wires. Connecting the ground wires may cause I/O signal errors.
- ♦ Keep the power supply for pulse commands and error counter reset input lines separated from the control power supply as far as possible. In particular, do not connect the 2 power supply ground wires.
- ♦ We recommend using line drives for the pulse command and error counter reset outputs.
- ♦ Always use twisted-pair shielded cable for the pulse command and error counter reset signal lines, and connect both ends of the shield cable to frame grounds.
- ♦ If the control power supply wiring is long, noise resistance can be improved by adding 1- μ F laminated ceramic capacitors between the control power supply and ground at the drive input section or the controller output section.
- ♦ For open collector specifications, keep the length of wires to within 2 m.

Reactor to Reduce Harmonic Current

Harmonic Current Measures

- ♦ The Reactor is used for suppressing harmonic currents. The Reactor functions to suppress sudden and quick changes in electric currents.
- ♦ The Guidelines for Suppressing Harmonic Currents in Home Appliances and General Purpose Components require that manufacturers take appropriate remedies to suppress harmonic current emissions onto power supply lines.
- ♦ Select the proper Reactor model according to the Linear Servo Drive to be used.

Drive model	Reactor		
	Model	Rated current	Inductance
R88D-KT01L-L R88D-KT02H-L	3G3AX-DL2004	3.2 A	10.7 mH
R88D-KT02L-L R88D-KT04H-L	3G3AX-DL2007	6.1 A	6.75 mH
R88D-KT04L-L R88D-KT08H-L R88D-KT10H-L	3G3AX-DL2015	9.3 A	3.51 mH
R88D-KT15H-L	3G3AX-DL2022	13.8 A	2.51 mH
R88D-KT08H-L R88D-KT10H-L R88D-KT15H-L	3G3AX-AL2025	10.0 A	2.8 mH
R88D-KT20H-L	3G3AX-AL2055	20.0 A	0.88 mH

4-4 Regenerative Energy Absorption

The Linear Servo Drives have internal regeneration process circuitry, which absorbs the regenerative energy produced during motor deceleration and prevents the DC voltage from increasing. An overvoltage error occurs, however, if the amount of regenerative energy from the motor is too large. If this occurs, remedies must be taken to reduce the regenerative energy by changing operating patterns, or to increase the regeneration process capacity by connecting an External Regeneration Unit.

Calculating the Regenerative Energy

Horizontal Axis

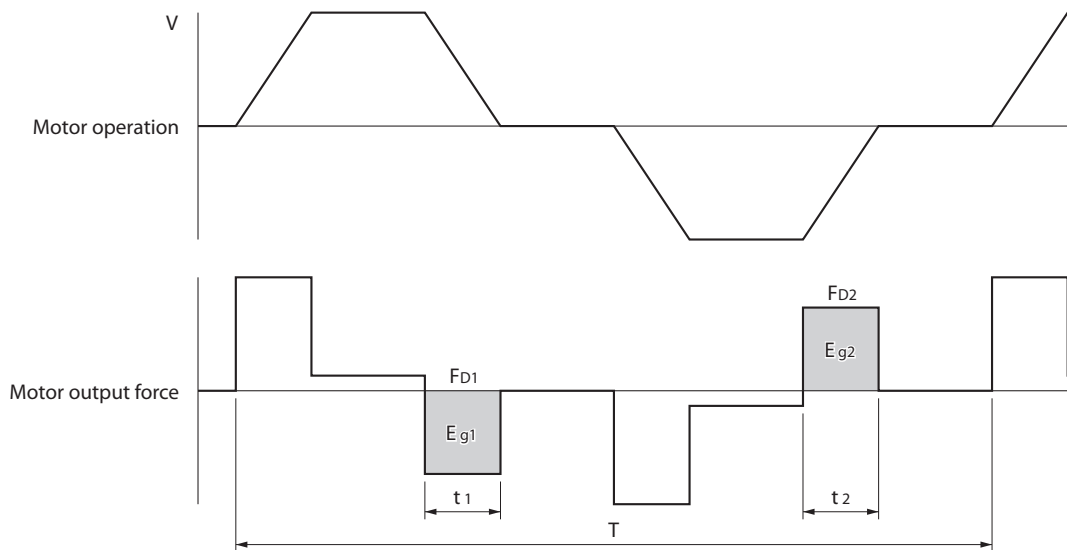

- In the output force graph, acceleration in the forward direction is shown as positive, and acceleration in the reverse direction is shown as negative.
- The regenerative energy values in each region can be derived from the following equations.

$$E_{g1} = \frac{1}{2} \cdot V_1 \cdot F_{D1} \cdot t_1 \quad [\text{J}]$$

$$E_{g2} = \frac{1}{2} \cdot V_2 \cdot F_{D2} \cdot t_2 \quad [\text{J}]$$

V_1, V_2 : Speed at start of deceleration [mm/s]

F_{D1}, F_{D2} : Deceleration Force [N]

t_1, t_2 : Deceleration time [s]

Note. Due to the loss of motor winding resistance and PWM, the actual regenerative energy will be approximately 90% of the values derived from these equations.

- For drive models with internal capacitors used for absorbing regenerative energy (models of 400W or less), the values for both E_{g1} or E_{g2} (J) must be lower than the drive's regeneration absorption capacity. (The capacity depends on the model. For details, refer to the next section.)
- For drive models with an Internal Regeneration Resistor used for absorbing regenerative energy (models of 600 W or more), the average amount of regeneration P_r (W) must be calculated, and this value must be lower than the drive's regenerative absorption capacity. (The capacity depends on the model. For details, refer to the next section.)

The average regeneration power (P_r) is the regeneration power produced in 1 cycle of operation [W].

$$P_r = (E_{g1} + E_{g2}) / T [\text{W}]$$

T: Operation cycle [s]

Vertical Axis

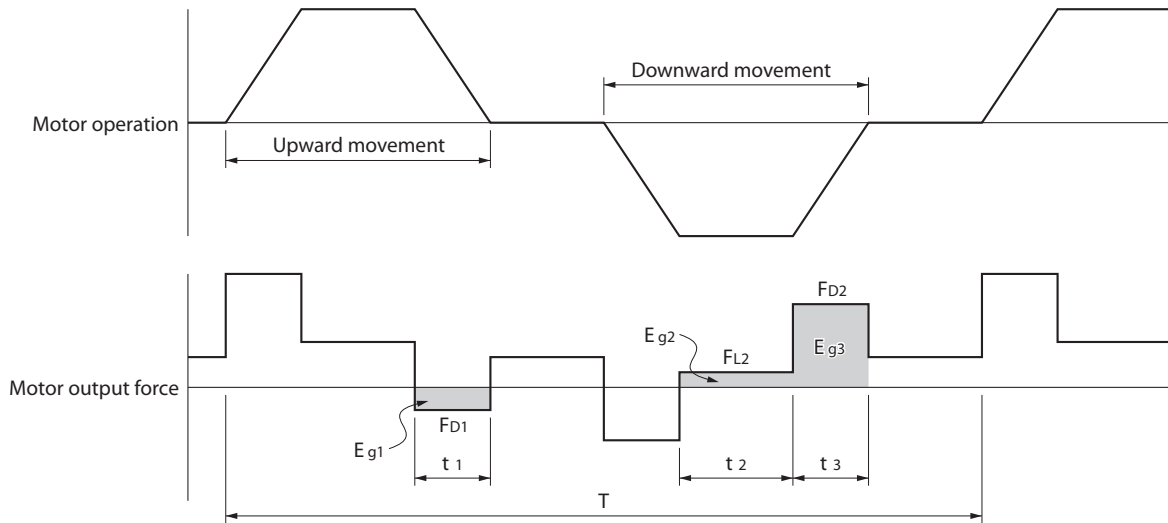

♦ In the output force graph, acceleration in the forward direction (rising) is shown as positive, and acceleration in the reverse direction (falling) is shown as negative.

♦ The regenerative energy values in each region can be derived from the following equations.

$$E_{g1} = \frac{1}{2} \cdot V_1 \cdot F_{D1} \cdot t_1 \quad [J]$$

$$E_{g2} = V_2 \cdot F_{L2} \cdot t_2 \quad [J]$$

$$E_{g3} = \frac{1}{2} \cdot V_3 \cdot F_{D2} \cdot t_3 \quad [J]$$

V_1, V_2 : Speed at start of deceleration [mm/s]

F_{D1}, F_{D2} : Deceleration force [N]

F_{L2} : Force during downward movement [N]

t_1, t_3 : Deceleration time [s]

t_2 : Constant-speed driving time during downward movement [s]

Note. Due to the loss of winding resistance, the actual regenerative energy will be approximately 90% of the values derived from these equations.

- ♦ For drive models with internal capacitors used for absorbing regenerative energy (models of 400W or less), the values for both E_{g1} or $E_{g2} + E_{g3}$ (J) must be lower than the drive's regeneration absorption capacity. (The capacity depends on the model. For details, refer to the next section.)
- ♦ For drive models with an Internal Regeneration Resistor used for absorbing regenerative energy (models of 600 W or more), the average amount of regeneration P_r (W) must be calculated, and this value must be lower than the drive's regeneration absorption capacity. (The capacity depends on the model. For details, refer to the next section.)

The average regeneration power (P_r) is the regeneration power produced in 1 cycle of operation [W].

$$P_r = (E_{g1} + E_{g2} + E_{g3}) / T \quad [W]$$

T: Operation cycle [s]

Drive Regeneration Absorption Capacity

Amount of Internal Regeneration Absorption in Drives

This drive absorbs regenerative energy internally with built-in capacitors.

If the regenerative energy is too large to be processed internally, an overvoltage error occurs and operation cannot continue.

The following table shows the regenerative energy (and amount of regeneration) that each drive can absorb. If these values are exceeded, take the following processes.

- ♦ Connect an External Regeneration Unit. (Regeneration process capacity improves.)
- ♦ Reduce the operating speed. (The amount of regeneration is proportional to the square of the speed.)
- ♦ Lengthen the deceleration time. (Regenerative energy per unit time decreases.)
- ♦ Lengthen the operation cycle, i.e., the cycle time. (Average regenerative power decreases.)

Servo Drive model	Regenerative energy (J) that can be absorbed by internal capacitor	Internal regeneration resistance	Minimum value of regeneration resistance (Ω)
		Average amount of regeneration that can be absorbed (W)	
R88D-KT01L-L	16	–	17
R88D-KT02L-L	22	–	17
R88D-KT04L-L	32	17	13
R88D-KT02H-L	25	–	34
R88D-KT04H-L	36	–	34
R88D-KT08H-L	62	12	25
R88D-KT10H-L	99	18	25
R88D-KT15H-L	99	18	25
R88D-KT20H-L	99	72	10
R88D-KT06F-L	128	21	100
R88D-KT10F-L	128	21	100
R88D-KT15F-L	128	21	100
R88D-KT20F-L	128	29	40
R88D-KT30F-L	285	60	40
R88D-KT50F-L	285	60	29

Regenerative Energy Absorption with an External Regeneration Resistor

If the regenerative energy exceeds the regeneration absorption capacity of the drive, connect an External Regeneration Resistor.

Connect the External Regeneration Resistor between B1 and B2 terminals on the drive.

Do not forget to remove the connection between B2 and B3 if present.

Double-check the terminal names when connecting the resistor because the drive may be damaged if connected to the wrong terminals.

The External Regeneration Resistor will heat up to approx. 120°C. Do not place it near equipment and wiring that is easily affected by heat. Attach radiator plates suitable for the heat radiation conditions.

External Regeneration Resistor

Characteristics

Model	Resistance value	Nominal capacity	The amount of regeneration absorption for 120°C temperature rise	Heat radiation condition	Thermal switch output specifications
R88A-RR08050S	50 Ω	80 W	20 W	Aluminum 250 × 250, Thickness: 3.0	Operating temperature 150°C ± 5% NC contact Rated output: 30 VDC, – 50 mA max.
R88A-RR080100S	100 Ω	80 W	20 W	Aluminum 250 × 250, Thickness: 3.0	Operating temperature 150°C ± 5% NC contact Rated output: 30 VDC, – 50 mA max.
R88A-RR22047S	47 Ω	220 W	70 W	Aluminum 350 × 350, Thickness: 3.0	Operating temperature: 170 ± 7°C NC contact Rated output: 250 VAC, 0.2 A max.
R88A-RR50020S	20 Ω	500 W	180 W	Aluminum 600 × 600, Thickness: 3.0	Operating temperature 200 ± 7°C NC contact Rated output: 250 VAC, 0.2 A max. 24 VDC, 0.2 A max.

Connecting an External Regeneration Resistor

R88D-KT01L-L/-KT02L-L/-KT02H-L/-KT04H-L

Normally B2 and B3 are open.

If an External Regeneration Resistor is necessary, remove the short-circuit bar between B2 and B3, and then connect the External Regeneration Resistor between B1 and B2 as shown in the diagram below.

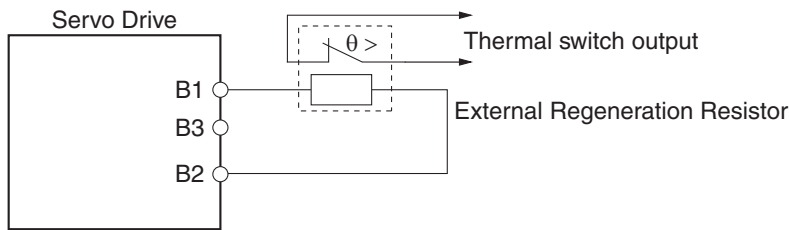

Precautions for Correct Use

- ◆ Connect the thermal switch output so that the main circuit power supply is shut OFF when the contacts open.
When using multiple External Regeneration Resistors, connect each thermal switch in series.
The resistor may be damaged by burning, or cause fire if it is used without setting up a power supply shutoff sequence using the output from the thermal switch.

R88D-KT04L-L/-KT08H-L/-KT10H-L/-KT15H-L/-KT20H-L/-KT06F-L/-KT10F-L/-KT15F-L/-KT20F-L/-KT30F-L/-KT50F-L

Normally B2 and B3 are short-circuited.

If an External Regeneration Resistor is necessary, remove the short-circuit bar between B2 and B3, and then connect the External Regeneration Resistor between B1 and B2 as shown in the diagram below.

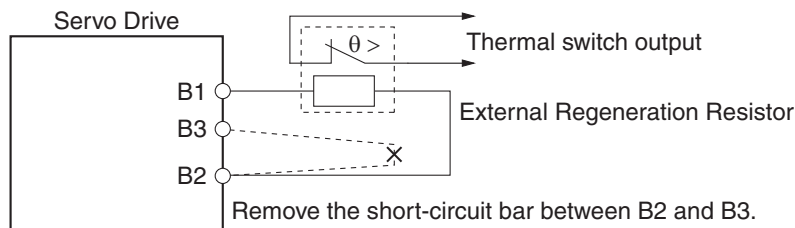

Precautions for Correct Use

- ◆ Connect the thermal switch output so that the main circuit power supply is shut OFF when the contacts open.
When using multiple External Regeneration Resistors, connect each thermal switch in series.
The resistor may be damaged by burning, or cause fire if it is used without setting up a power supply shutoff sequence using the output from the thermal switch.

Combining External Regeneration Resistors

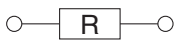
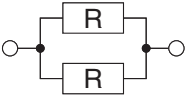
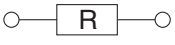
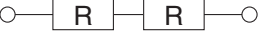
Regeneration absorption capacity ^{*1}	20 W	40 W	70 W	140 W
Model	R88A-RR08050S R88A-RR080100S	R88A-RR08050S R88A-RR080100S	R88A-RR22047S	R88A-RR22047S
Resistance value ^{*2}	50 Ω/100 Ω	25 Ω/50 Ω	47 Ω	94 Ω
Connection method				

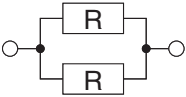
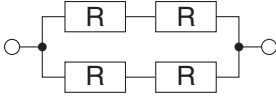
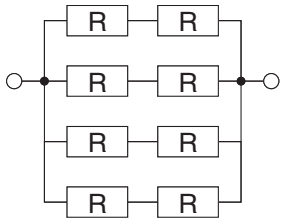
Regeneration absorption capacity ^{*1}	140 W	280 W	560 W
Model	R88A-RR22047S	R88A-RR22047S	R88A-RR22047S
Resistance value ^{*2}	23.5 Ω	47 Ω	23.5 Ω
Connection method			

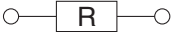
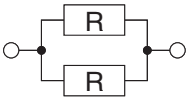
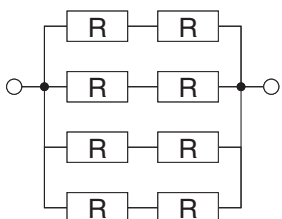
Regeneration absorption capacity ^{*1}	180 W	360 W	1440 W
Model	R88A-RR50020S	R88A-RR50020S	R88A-RR50020S
Resistance value ^{*2}	20 Ω	10 Ω	10 Ω
Connection method			

*1. Select a combination that has an absorption capacity greater than the average regeneration power (Pr).
 *2. Do not use a combination with resistance values lower than the minimum external regeneration resistance of each drive. For information on the minimum external regeneration resistance, refer to "Drive Regeneration Absorption Capacity"(P.4-46).



Safety Points







- ◆ Surface temperatures on regeneration resistance can reach 200°C. Do not place objects that tend to catch fire nearby. To prevent people from touching them, install a type of cover that enables heat dissipation.

4-4 Regenerative Energy Absorption

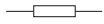
Recommended regeneration resistor combination:

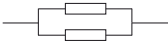
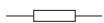
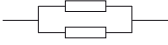
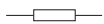
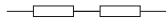
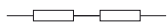
This is an example of resistor combination per drive selected with next criteria:

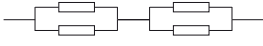
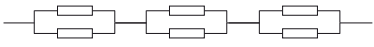
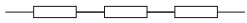
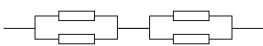
- Braking power between 10 to 15% of drive value.
- Ohmic value of the group higher than the minimum drive value.
- Serial-parallel combination of resistors is symmetrical so the temperature in all resistors will be similar.

Drive	Resistor	Combination	Total Power	Total Ohms
R88D-KT01L-L	R88ARR08050S	A 	20W	50Ω
R88D-KT02L-L	R88ARR08050S	A 	20W	50Ω
R88D-KT04L-L	R88ARR08050S	A//A 	40W	25Ω
R88D-KT02H-L	R88ARR08050S	A 	20W	50Ω
R88D-KT04H-L	R88ARR08100S	B//B 	40W	50Ω
R88D-KT08H-L	R88ARR22047S	C 	70W	47Ω
R88D-KT10H-L	R88ARR22047S	C-C 	140W	94Ω
R88D-KT15H-L	R88ARR22047S	C-C 	140W	94Ω
R88D-KT20H-L	R88ARR22047S	C//C//C 	210W	15.6Ω
R88D-KT06F-L	R88ARR08100S	B//B-B//B 	80W	100Ω*
R88D-KT10F-L	R88ARR08100S	B//B-B//B-B//B 	120W	150Ω
R88D-KT15F-L	R88ARR22047S	C-C-C 	210W	131Ω
R88D-KT20F-L	R88ARR22047S	C//C-C//C 	280W	47Ω
R88D-KT30F-L	R88ARR50020S	D-D 	360W	40Ω*
R88D-KT50F-L	R88ARR50020S	D//D-D//D-D//D 	980W	30Ω

*The ohmic value corresponds with the minimum allowable value in the drive. Verify that the total group is not below this value due to component tolerances, otherwise the drive may be damaged.

5

BASIC CONTROL Mode

This chapter explains an outline of operations available in various CONTROL modes and explains the contents of setting.

5-1	Position Control	5-2
	Outline of Operation	5-2
	Parameters Requiring Settings	5-3
	Related Functions	5-6
	Parameter Block Diagram for POSITION CONTROL mode	5-7
5-2	Speed Control	5-8
	Outline of Operation	5-8
	Parameters Requiring Settings	5-8
	Related Functions	5-12
	Parameter Block Diagram for SPEED CONTROL mode	5-13
5-3	Force Control	5-14
	Outline of Operation	5-14
	Parameters Requiring Settings	5-14
	Related Functions	5-17
	Parameter Block Diagram for FORCE CONTROL mode	5-18
5-4	Internally Set Speed Control	5-19
	Outline of Operation	5-19
	Parameters Requiring Settings	5-19
5-5	Switching Control	5-22
	Outline of Operation	5-22
	Parameters Requiring Settings	5-22
	Related Functions	5-24

5-1 Position Control

Outline of Operation

- ◆ Position control is performed based on the pulse train input received from the controller.
- ◆ The motor moves using the value of the pulse train input multiplied by the Electronic Gear (Pn009 to Pn010).

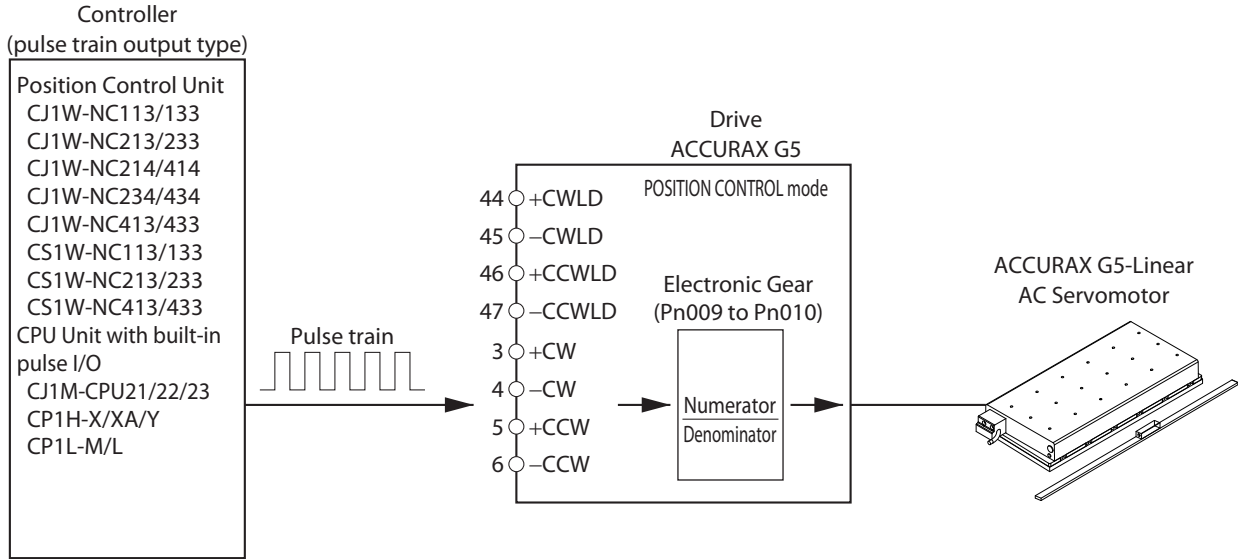

5 BASIC CONTROL Mode

Parameters Requiring Settings

Parameter number	Parameter name	Explanation	Reference
Pn000	Reference direction	Select the relation between the reference command and the movement direction in the motor.	P.8-2
Pn001	CONTROL mode Selection	Select the CONTROL mode.	P.8-2
Pn005	Command Pulse Input Selection	Select the command pulse input terminal.	P.8-4
Pn006	Command Pulse Direction Switching Selection	Set the count direction for the command pulse input.	P.8-4
Pn007	COMMAND PULSE mode Selection	Set the count method for the command pulse input.	P.8-4
Pn009	Electronic Ratio Numerator 1	Set the numerator of the electronic ratio for the command pulse input.	P.8-6
Pn010	Electronic Ratio Denominator	Set the denominator of the electronic ratio for the command pulse input.	P.8-6

CONTROL Mode Selection (Pn001)

Select the position control (Set values: 0=Position control, 3=Switch between position control and speed control or 4=Switch between position control and force control).

Command Pulse Input Process (Pn005, Pn006, Pn007)

Position command input terminals are classified into the input 1 system (+CW, -CW, +CCW, -CCW) and input 2 system (+CWLD, -CWLD, +CCWLD, -CCWLD).

If the position command output is a line-drive output, set input 1. If it is an open collector output, set input 2. Although input 2 can also be used for a line-drive output, the allowable maximum input frequency will become lower than when input 1 is selected.

5-1 Position Control

Parameter number	Parameter name	Explanation	Setting range	Unit
Pn005	Command Pulse Input Selection	Select the command pulse input terminal. 0: Photocoupler input (+CW, -CW, +CCW, -CCW) 1: Input for line drive only (+CWLD, -CWLD, +CCWLD, -CCWLD)	0 to 1	–
Pn006	Command Pulse Direction Switching Selection	Set the count direction for the command pulse input. 0: Command pulse, forward direction 1: Command pulse, reverse direction	0 to 1	–
Pn007	COMMAND PULSE mode Selection	Set the count method for the command pulse input. 0: 90 phase difference (A/B) signal input) 1: Forward/reverse pulse 2: 90 phase difference (A/B) signal input) 3: Feed pulse/direction signal	0 to 3	–

The settings for command movement direction and COMMAND PULSE mode are as follows.

Pn006	Pn007	Command pulse pattern	Signal name	Forward direction command	Reverse direction command
0	0 or 2	90° phase difference, 2-phase pulse (phase A + phase B)	CW		
			CCW	Phase B is 90° ahead of phase A.	Phase B is 90° behind phase A.
	1	Forward direction pulse train + Reverse direction pulse train	CW		
			CCW		
	3	Pulse train + Sign	CW		
			CCW		
1	0 or 2	90° phase difference, 2-phase pulse (phase A + phase B)	CW		
			CCW	Phase B is 90° behind phase A.	Phase B is 90° ahead of phase A.
	1	Forward direction pulse train + Reverse direction pulse train	CW		
			CCW		
	3	Pulse train + Sign	CW		
			CCW		

Symbol	Allowable input maximum frequency	Minimum required duration [μs]					
		t1	t2	t3	t4	t5	t6
+CWLD, -CWLD, +CCWLD, -CCWLD	4 Mpps	0.25	0.125	0.125	0.125	0.125	0.125
+CW, -CW, +CCW, -CCW	Line drive	500 kpps	2	1	1	1	1
	Open collector	200 kpps	5	2.5	2.5	2.5	2.5

Electronic Gear Function (Pn009, Pn010)

This function allows to adjust the units of the command pulses by setting a ratio between the encoder pulses and the command pulses.

Parameter number	Parameter name	Explanation	Setting range	Unit
Pn009	Electronic Ratio Numerator 1	Set the numerator of the electronic ratio for the command pulse input.	1 to 2 ³⁰	–
Pn010	Electronic Ratio Denominator	Set the denominator of the electronic ratio for the command pulse input.	1 to 2 ³⁰	–

♦ For details on the electronic gear function, refer to P.6-12.

Related Functions

Parameter number	Parameter name	Explanation	Reference
Pn011	Encoder Dividing Numerator	Set the pulse output resolution using the numbers of output pulses per movement for OA and OB, respectively.	P.8-7
Pn012	Encoder Output Direction Switching Selection	Set the phase-B logic and output source for pulse output.	P.8-7
Pn222	Position Command Filter Time Constant	Set the time constant of the first-order lag filter for the position command.	P.8-23
Pn223	Smoothing Filter Time Constant	Set the time constant of the FIR filter for the position command.	P.8-24
Pn431	Positioning Completion Range 1	Set the threshold of position error for output of the positioning completion signal.	P.8-40
Pn432	Positioning Completion Condition Selection	Select the condition under which the positioning completion signal is output.	P.8-41
Pn433	Positioning Completion Hold Time	Set the INP signal output time.	P.8-41
Pn503	Encoder Dividing Denominator	You can set a dividing ratio by using Encoder Dividing Numerator (Pn011) as the dividing numerator and Encoder Dividing Denominator (Pn503) as the dividing denominator.	P.8-45
Pn517	Error Counter Reset Condition Selection	Set the reset condition under which the error counter reset input signal.	P.8-51
Pn518	Command Pulse Prohibition Input Setting	Set whether to enable or disable the command pulse prohibition input.	P.8-51

Parameter Block Diagram for POSITION CONTROL mode

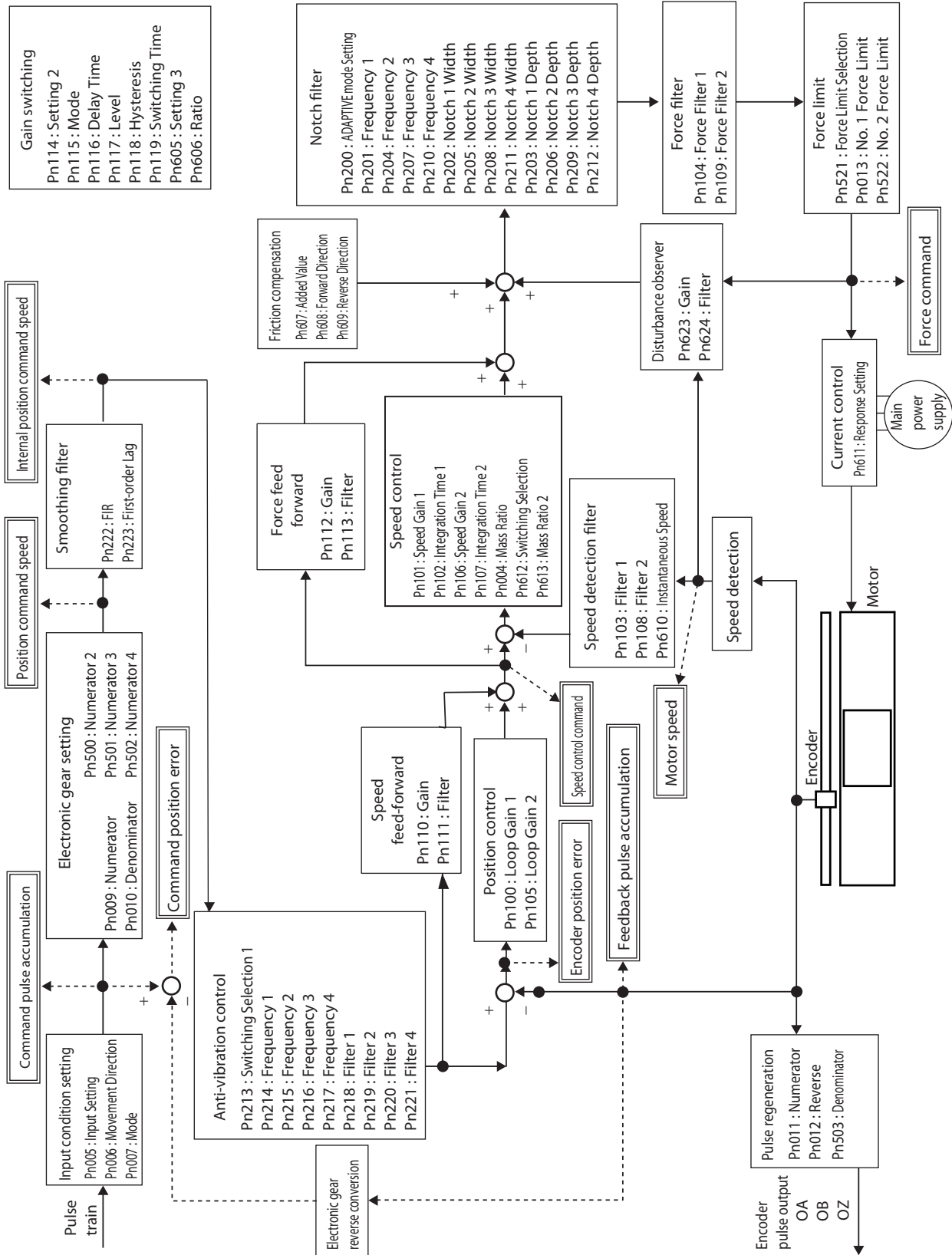

5-2 Speed Control

Outline of Operation

- Motor speed control is performed based on the analog voltage input from the controller. You can also perform position control by combining with a controller that has a position control function.
- You can change the relation between the speed command and the speed by setting the Speed Command Scale (Pn302).

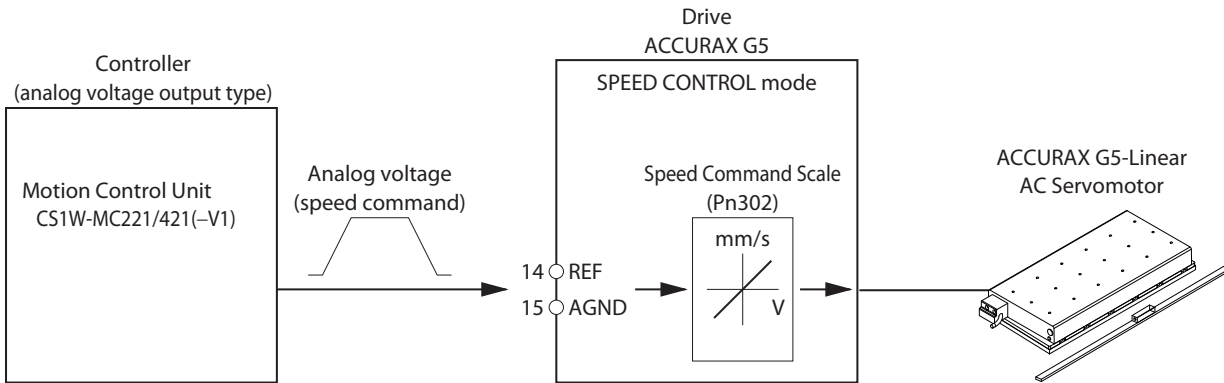

Parameters Requiring Settings

Parameter number	Parameter name	Explanation	Reference
Pn000	Reference direction	Select the relation between the reference command and the direction in the motor.	P.8-2
Pn001	CONTROL mode Selection	Select the CONTROL mode.	P.8-2
Pn300	Command Speed Selection	Select the speed command input method.	P.8-25
Pn301	Speed Command Direction Selection	Set the method for designating the forward or reverse direction for the speed command.	P.8-25
Pn302	Speed Command Scale	Set the input gain for the analog speed command input.	P.8-26
Pn303	Analog Speed Command Movement Direction Switching	Inverts the polarity of the analogue speed command.	P.8-26
Pn312	Soft Start Acceleration Time	Set the acceleration time for internally set speed control. Set the time until 1,000 mm/s is reached.	P.8-27
Pn313	Soft Start Deceleration Time	Set the deceleration time for internally set speed control. Set the time until 1,000 mm/s is reached.	P.8-28
Pn314	S-curve Acceleration/Deceleration Time Setting	Set the S-curve time in the time width centered on the inflection points for acceleration and deceleration.	P.8-28

CONTROL mode Selection (Pn001)

Select the speed control (Set values: 1=Speed control, 3=Switching between position and speed control or 5=Switching between speed control and force control).

Analog Speed Command Input Process (Pn300, Pn301, Pn302, Pn303)

Convert the voltage input by an analog input to a speed command to control the motor.

Parameter number	Parameter name	Explanation	Setting range	Unit
Pn300	Command Speed Selection	Select the speed command input method. 0: Analog speed command 1: No. 1 to 4 internally set speed 2: No. 1 to 3 internally set speed, analog speed command 3: No. 1 to 8 internally set speed	0 to 3	–
Pn301	Speed Command Direction Selection	Select the method for designating the direction for the speed command. 0: By analogue command polarity 1: By digital input (VSIGN)	0 to 1	–
Pn302	Speed Command Scale	Set the input gain for the analog speed command input.	0 to 2000	(mm/s)/V
Pn303	Analog Speed Command Direction Switching	Set to reverse the polarity of the speed command input. 0: The +command indicates the forward direction as in the direction of the motor cables. 1: The +command indicates the reverse direction as contrary to the motor cables.	0 to 1	–

The conversion of analog speed command is explained below.

Command Speed Selection (Pn300)	Speed Command Direction Selection (Pn301)	Analog Speed Command Direction Switching (Pn303)	Analog speed command (REF)	Speed command sign selection (VSIGN)	Motor direction	Conversion graph	
0	0	0	+Voltage (0 to 10 V)	Not affected	Forward direction	Figure A	
			-Voltage (-10 to 0 V)	Not affected	Reverse direction		
		1	+Voltage (0 to 10 V)	Not affected	Reverse direction	Figure B	
			-Voltage (-10 to 0 V)	Not affected	Forward direction		
	1	Not affected	OFF	+Voltage (0 to 10 V)	OFF	Forward direction	Figure C
				-Voltage (-10 to 0 V)			
			ON	+Voltage (0 to 10 V)	ON	Reverse direction	
				-Voltage (-10 to 0 V)			

5-2 Speed Control

Example: When Speed Command Scale (Pn302) = 500

$$\text{Speed command value} = \text{Speed Command Scale (Pn302)} \times \text{input voltage}$$

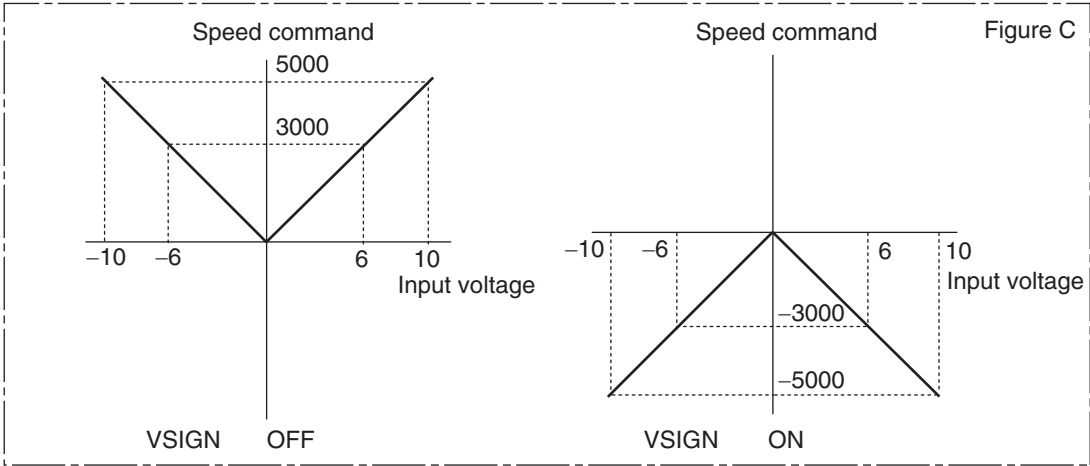
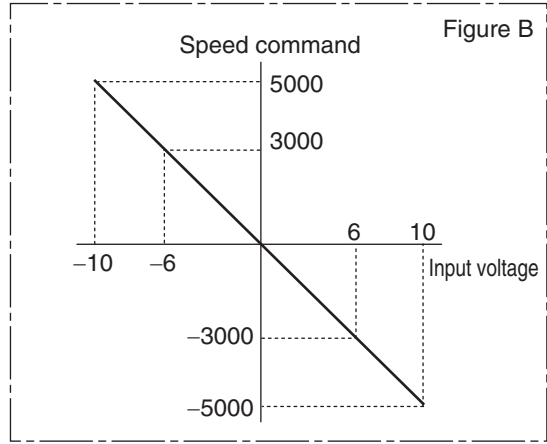
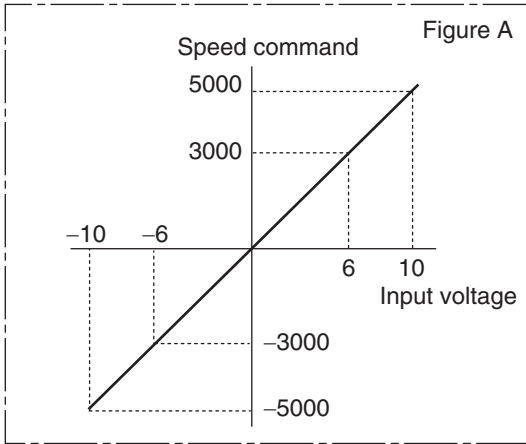

Speed Command Acceleration/Deceleration Setting Function (Pn312, Pn313, Pn314)

With a step speed command, you can change the speed command based on this setting to reduce the shock caused by change in acceleration.

Parameter number	Parameter name	Explanation	Setting range	Unit
Pn312	Soft Start Acceleration Time	Set the acceleration time for acceleration process with respect to the speed command input.	0 to 10000	ms/(1,000 mm/s)
Pn313	Soft Start Deceleration Time	Set the deceleration processing deceleration time for speed command inputs.	0 to 10000	ms/(1,000 mm/s)
Pn314	S-curve Acceleration/Deceleration Time Setting	Set the S-curve acceleration/ deceleration time.	0 to 1000	ms

Soft Start Acceleration Time (Pn312), Soft Start Deceleration Time (Pn313)

If a step speed command is input, set in Soft Start Acceleration Time (Pn312) the time needed for the speed command to reach 1,000 mm/s. Also set in Soft Start Deceleration Time (Pn313) the time needed for the speed command to reach 0 mm/s from 1,000 mm/s.

Soft start acceleration time [ms] = $V_c/1,000 \times Pn312 \times 1$ ms
 Soft start deceleration time [ms] = $V_c/1,000 \times Pn313 \times 1$ ms

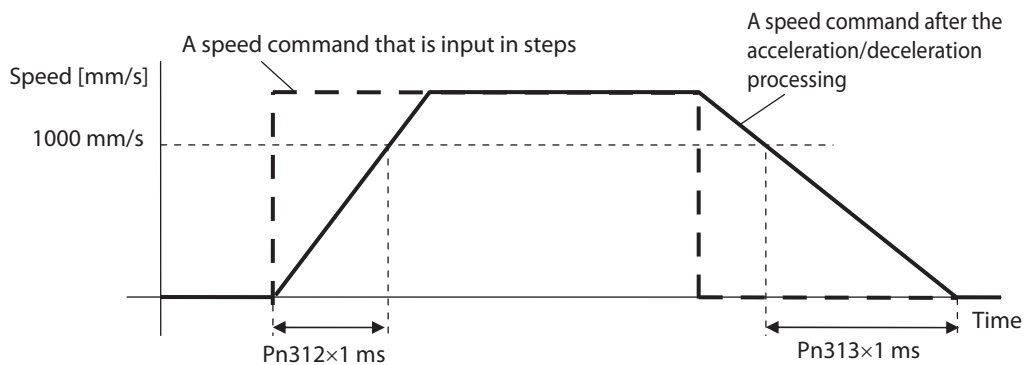

S-curve Acceleration/Deceleration Time Setting (Pn314)

Set the S-curve time in the time width centered on the inflection points in acceleration/deceleration relative to the acceleration or deceleration time set in Soft Start Acceleration Time (Pn312) or Soft Start Deceleration Time (Pn313).

$t_a = V_c/1,000 \times Pn312 \times 1$ ms
 $t_d = V_c/1,000 \times Pn313 \times 1$ ms
 $t_s = Pn314 \times 1$ ms

Set an appropriate time so that $t_a > t_s$ and $t_d > t_s$ are satisfied.

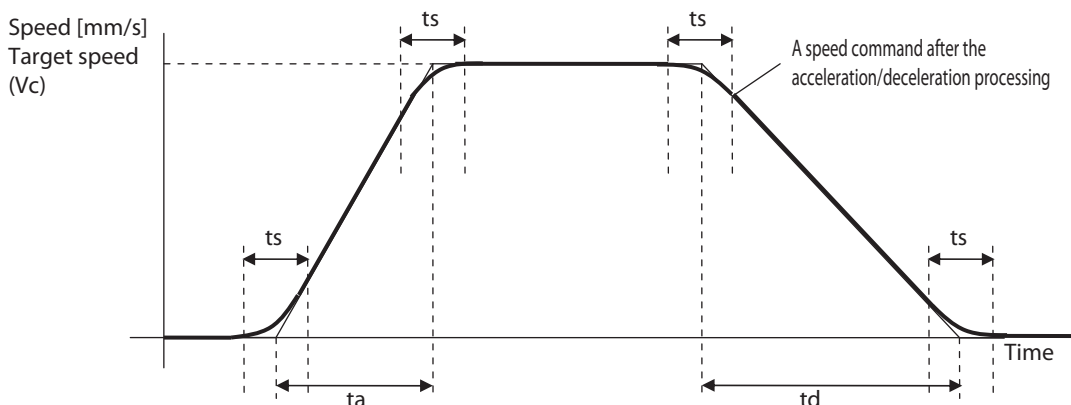

Related Functions

Parameter number	Parameter name	Explanation	Reference
Pn315	Zero Speed Designation Selection	Set the zero speed designation.	P.8-28
Pn316	Speed Lock Level Setting	Set the threshold for transition to the servo lock state under position control.	P.8-30
Pn435	Speed Conformity Detection Range	Set the detection threshold for speed conformity output. If the difference between the speed command and motor speed is within the set threshold, a speed conformity output is output. This setting has a hysteresis of 10 mm/s for detection.	P.8-42
Pn436	Speed for Motor Movement Detection	Set the detection threshold for speed reached output. A speed reached output is output when the motor speed exceeds the set value. This setting has a hysteresis of 10 mm/s for detection.	P.8-42
Pn422	Analog Input 1 Offset	Set the analog input 1 offset.	P.8-38
Pn423	Analog Input 1 Filter Time Constant	Set the filter for analog input 1.	P.8-39

Parameter Block Diagram for SPEED CONTROL mode

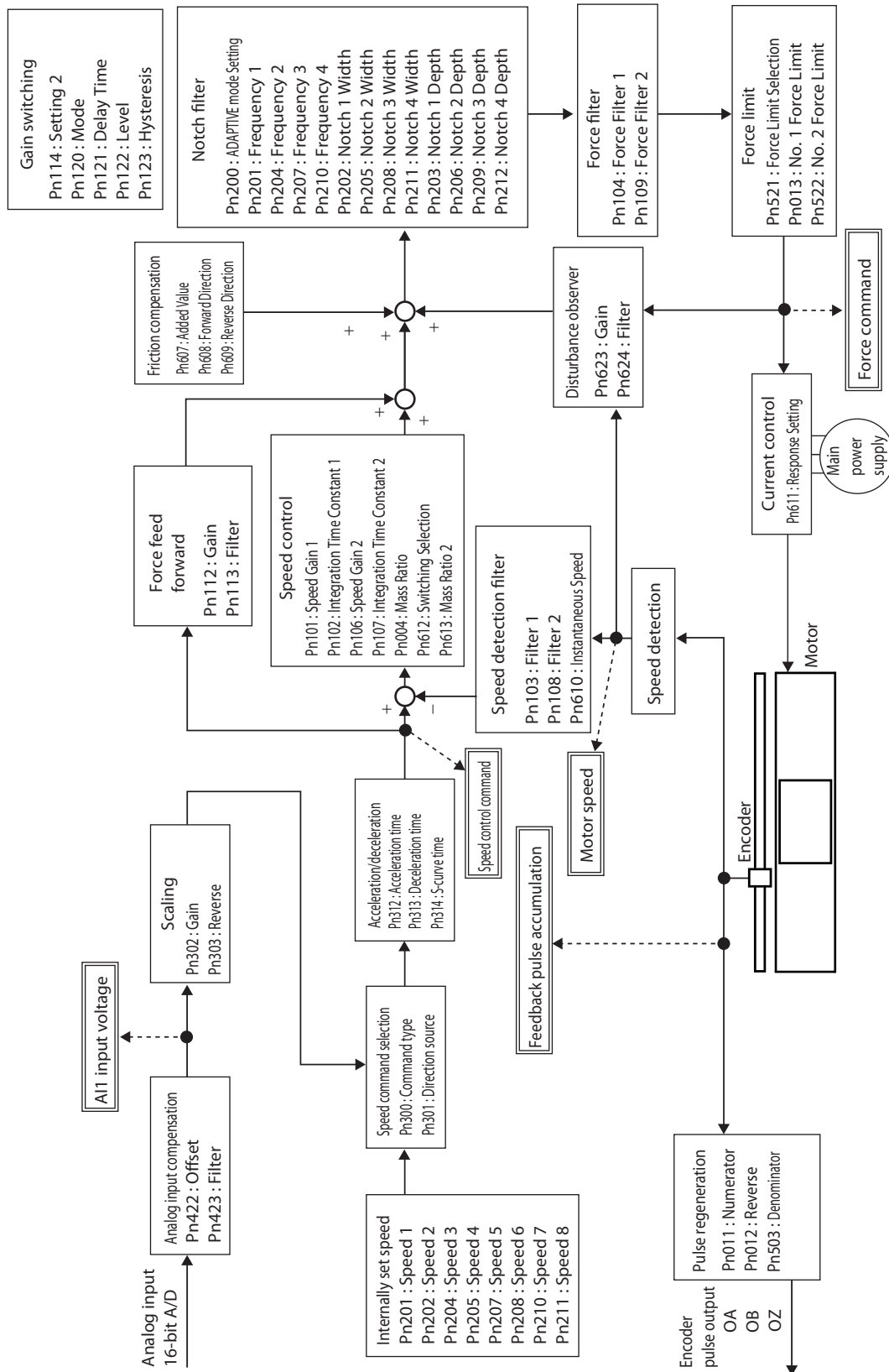

5-3 Force Control

Force control is performed based on the force command specified by the analog voltage. In addition to the force command, force control also requires a speed limit input to prevent the motor speed from becoming excessively high.

Outline of Operation

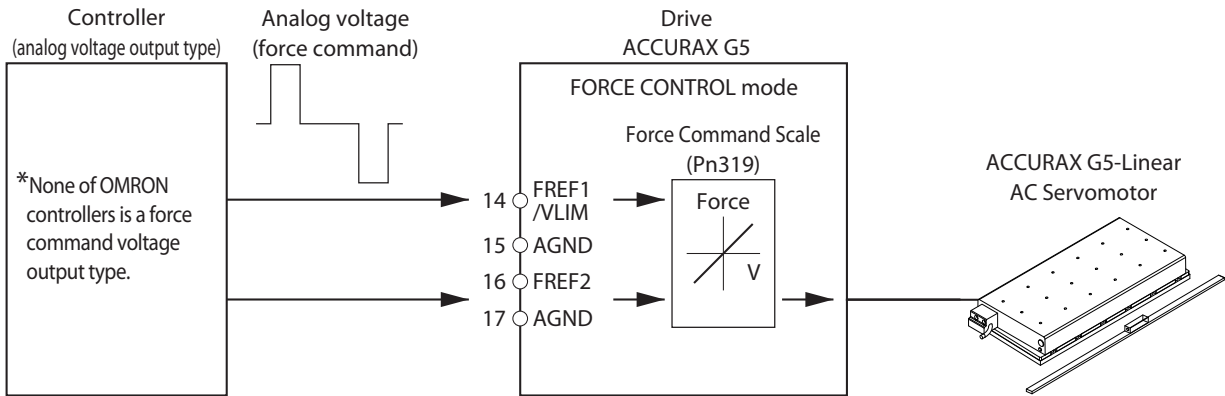

Precautions for Correct Use

- ◆ If the motor speed is limited by the speed limit, the motor speed will be limited and will not reach the speed corresponding to the analog force command.

Parameters Requiring Settings

Parameter number	Parameter name	Explanation	Reference
Pn001	CONTROL mode Selection	Select the CONTROL mode.	P.8-2
Pn317	Force Command/Speed Limit Selection	Select the input location for the force command and speed limit.	P.8-30
Pn318	Force Command Direction Selection	Select the direction of the force command.	P.8-30
Pn319	Force Command Scale	Set the input gain for analog force command input.	P.8-32
Pn320	Analog Force Command Direction Switching	Reverse the polarity of the force command input.	P.8-32

5 BASIC CONTROL Mode

CONTROL mode Selection (Pn001)

Select the force control (Set values: 2=Force control, 4=Switching between Position control and Force control or 5=Switching between Speed control and force control).

Analog Force Command Input Process (Pn317, Pn318, Pn319, Pn320)

Convert the voltage input by an analog input to a force command to control the motor.

Parameter number	Parameter name	Explanation	Setting range	Unit
Pn317	Force Command/Speed Limit Selection	Select the input location for the force command and speed limit value. 0: Force command: Analog input 1 speed limit: Pn321 1: Force command: Analog input 2 speed limit: Analog input 1 2: Force command: Analog input 1 speed limit: Pn321, Pn322	0 to 2	–
Pn318	Force Command Direction Selection	Select the method for selecting the direction for the force command. 0: The direction depends on the polarity of the analogue force command). 1: The direction depends on the state of a digital input (FSIGN).	0 to 1	–
Pn319	Force Command Scale	Set the input gain for analog force command input.	10 to 100	0.1 V/100%
Pn320	Analog Force Command Direction Switching	Reverse the polarity of the force command input. 0: Forward operation 1: Reverse operation	0 to 1	–

The conversion of analog force command is explained below.

Force Command/Speed Limit Selection (Pn317)	Force Command Direction Selection (Pn318)	Analog Force Command Direction Switching (Pn320)	Analog force command (FREF)	Force command sign input (FSIGN)	Motor direction	Conversion graph	
0	0	0	+Voltage (0 to 10 V)	Not affected	Forward direction	Figure A	
			-Voltage (-10 to 0 V)	Not affected	Reverse direction		
		1	+Voltage (0 to 10 V)	Not affected	Reverse direction	Figure B	
			-Voltage (-10 to 0 V)	Not affected	Forward direction		
	1	Not affected	OFF	+Voltage (0 to 10 V)	OFF	Forward direction	Figure C
				-Voltage (-10 to 0 V)			
			ON	+Voltage (0 to 10 V)	ON	Reverse direction	
				-Voltage (-10 to 0 V)			

5-3 Force Control

Example) When the force command scale is 30

$$\text{Force command} = 100 \times \text{Input voltage} / (\text{Force Command Scale (Pn302)} \times 0.1)$$

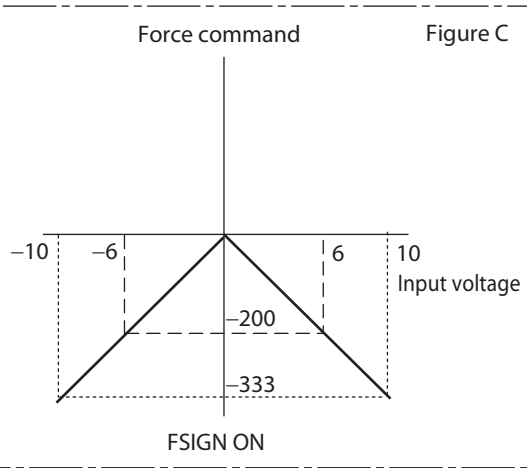
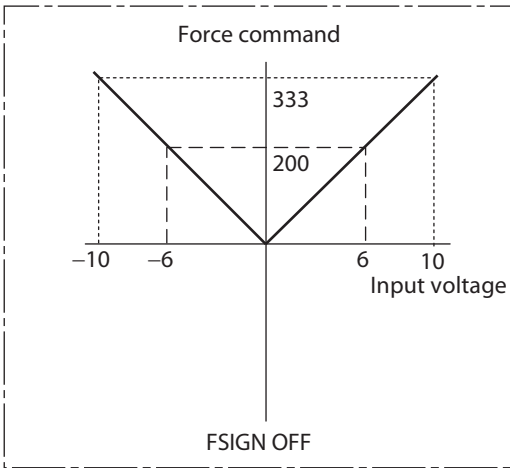
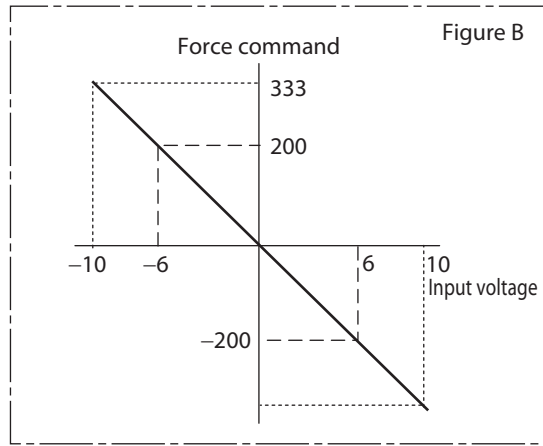
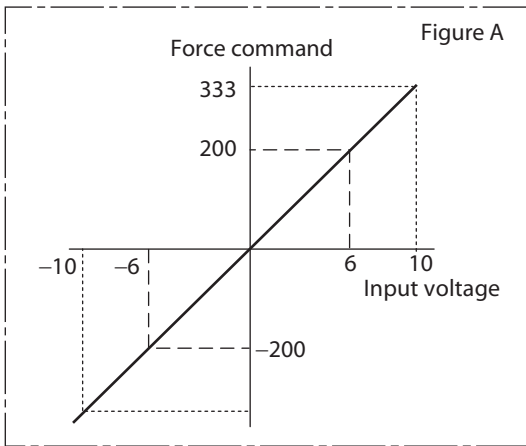

Related Functions

Parameter number	Parameter name	Explanation	Reference
Pn315	Zero Speed Designation Selection	Set the zero speed designation function.	P.8-28
Pn321	Speed Limit Value Setting	Set the speed limit value applicable during force control. During force control, the speed is controlled so as not to exceed the level set by the speed limit value.	P.8-32
Pn322	Reverse Direction Speed Limit Value Setting	Set this if you want to change the speed limit value depending on whether the direction is forward or reverse.	P.8-32
Pn422	Analog Input 1 Offset	Set the offset for analog input 1.	P.8-38
Pn423	Analog Input 1 Filter Time Constant	Set the filter for analog input 1.	P.8-39
Pn425	Analog Input 2 Offset	Set the offset for analog input 2.	P.8-39
Pn426	Analog Input 2 Filter Time Constant	Set the filter for analog input 2.	P.8-39

Parameter Block Diagram for FORCE CONTROL mode

5

BASIC CONTROL Mode

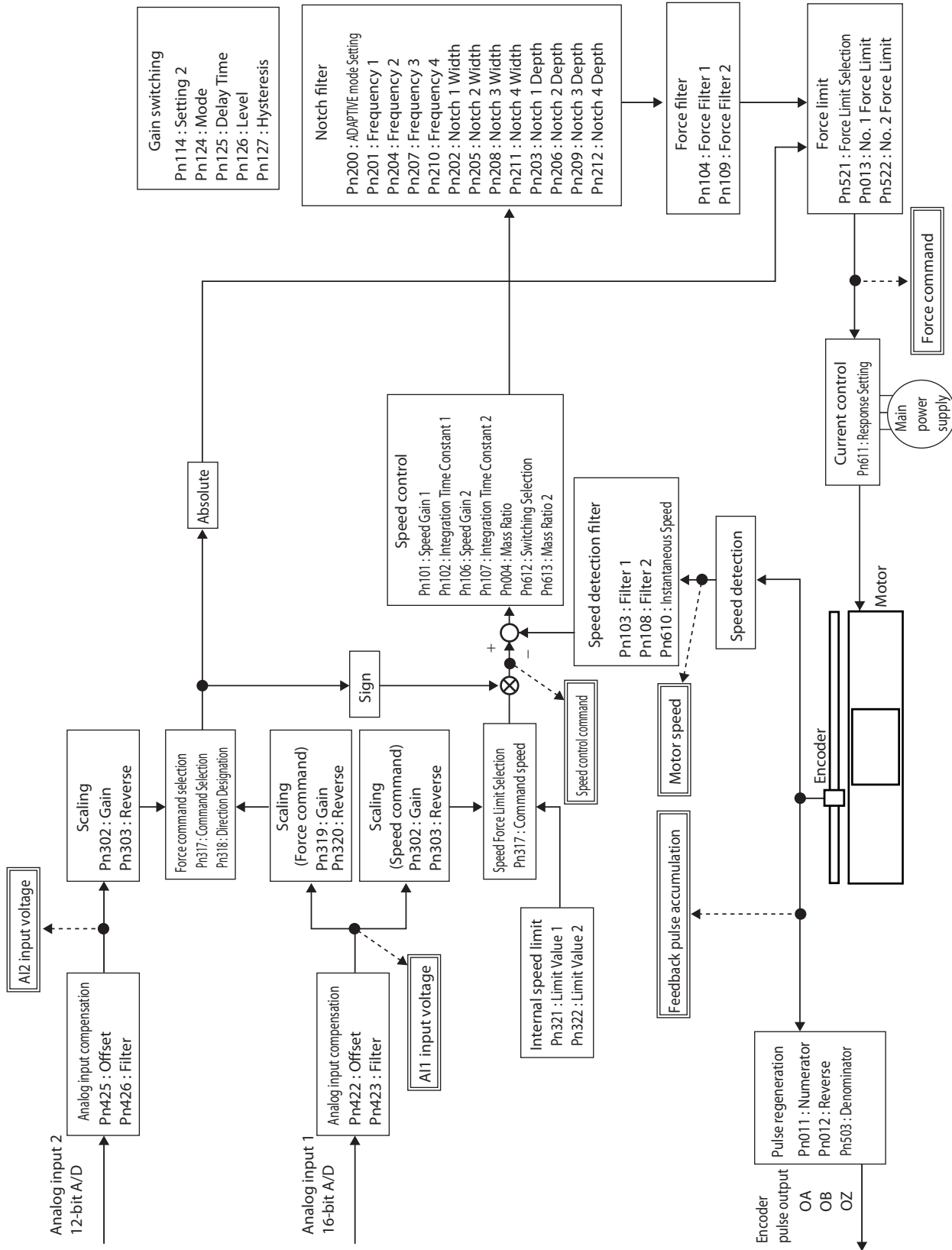

5-4 Internally Set Speed Control

Outline of Operation

- Performs motor speed control using the speeds set in the No. 1 to 8 Internally Speed Settings.
- Select the internally set speed using Internally Set Speed Selections 1 to 3 of the control input terminals (VSEL1: CN-1 to 33 pins, VSEL2: CN-1 to 30 pins, VSEL3: CN-1 to 28 pins).

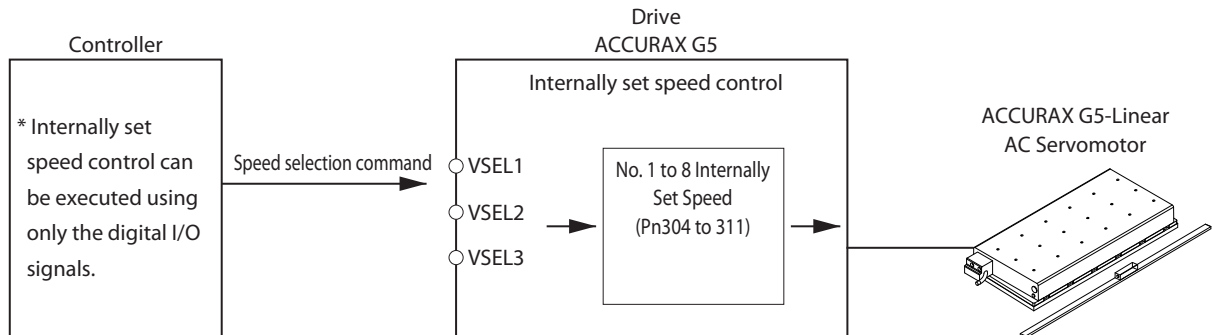

Parameters Requiring Settings

Parameter number	Parameter name	Explanation	Reference
Pn001	CONTROL mode Selection	Select the CONTROL mode for internally set speed control. (Set values: 1, 3 and 5)	P.8-2
Pn300	Command Speed Selection	Select the speed command input method.	P.8-25
Pn304	No. 1 Internally Set Speed	Set the internally set speeds (mm/s). The settings can be made from -20,000 to 20,000 mm/s. Be sure to set the speeds within the allowable range of speed of the motor.	P.8-26
Pn305	No. 2 Internally Set Speed		
Pn306	No. 3 Internally Set Speed		
Pn307	No. 4 Internally Set Speed		
Pn308	No. 5 Internally Set Speed		
Pn309	No. 6 Internally Set Speed		
Pn310	No. 7 Internally Set Speed		
Pn311	No. 8 Internally Set Speed		

Selecting the Internally Set Speeds

The following tables show the internally set speeds that are set with VSEL1, VSEL2 and VSEL3 (internally set speed selection 1, 2 and 3).

Pn300 = 1

Number	VSEL1	VSEL2	VSEL3	Set speed
0	OFF	OFF	Disabled	Pn304
1	ON	OFF	Disabled	Pn305
2	OFF	ON	Disabled	Pn306
3	ON	ON	Disabled	Pn307

Pn300 = 2

Number	VSEL1	VSEL2	VSEL3	Set speed
0	OFF	OFF	Disabled	Pn304
1	ON	OFF	Disabled	Pn305
2	OFF	ON	Disabled	Pn306
3	ON	ON	Disabled	*1

*1. The mode will be analog speed control.
Input the proper current to REF.

Pn300 = 3

Number	VSEL1	VSEL2	VSEL3	Set speed
0	OFF	OFF	OFF	Pn304
1	ON	OFF	OFF	Pn305
2	OFF	ON	OFF	Pn306
3	ON	ON	OFF	Pn307
4	OFF	OFF	ON	Pn308
5	ON	OFF	ON	Pn309
6	OFF	ON	ON	Pn310
7	ON	ON	ON	Pn311

Operation Example

- Internally set speed control with 4 speed changes when Pn300 = 1

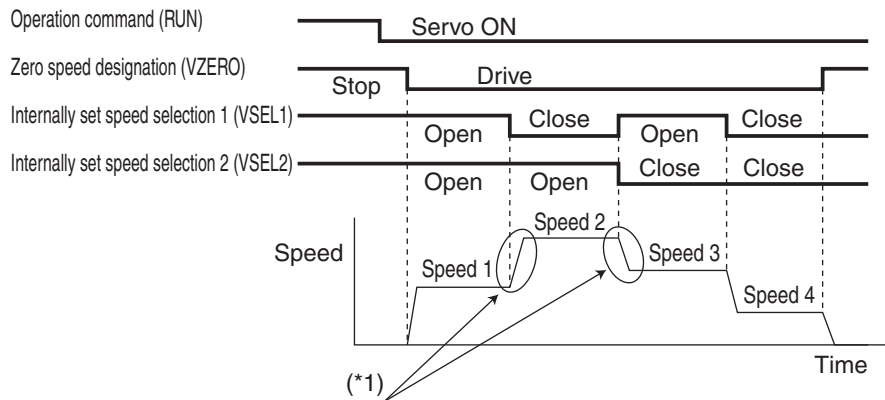

*1. The acceleration time, deceleration time, and S-curve acceleration/deceleration time can be set using parameters (Pn312, Pn313, and Pn314).

Internal Speed Command (Pn304 to 311)

Control the motor speed according to the internal speed command value set by a parameter. The internally set speed becomes valid when the setting of Speed Setting Internal/External Switching is 1 to 3.

Up to 8 internally set speeds can be set.

Parameter number	Parameter name	Explanation	Setting range	Unit
Pn304	No. 1 Internally Set Speed	Set the speed 1 internally set speed.	-20,000 to 20,000	mm/s
Pn305	No. 2 Internally Set Speed	Set the speed 2 internally set speed.	-20,000 to 20,000	mm/s
Pn306	No. 3 Internally Set Speed	Set the speed 3 internally set speed.	-20,000 to 20,000	mm/s
Pn307	No. 4 Internally Set Speed	Set the speed 4 internally set speed.	-20,000 to 20,000	mm/s
Pn308	No. 5 Internally Set Speed	Set the speed 5 internally set speed.	-20,000 to 20,000	mm/s
Pn309	No. 6 Internally Set Speed	Set the speed 6 internally set speed.	-20,000 to 20,000	mm/s
Pn310	No. 7 Internally Set Speed	Set the speed 7 internally set speed.	-20,000 to 20,000	mm/s
Pn311	No. 8 Internally Set Speed	Set the No. 8 internally set speed.	-20,000 to 20,000	mm/s

5-5 Switching Control

Outline of Operation

- ◆ This function controls the motor by switching between 2 CONTROL modes via external inputs.
- ◆ The CONTROL mode switching is performed by the CONTROL mode switching input (TVSEL: CN-1 pin 32).

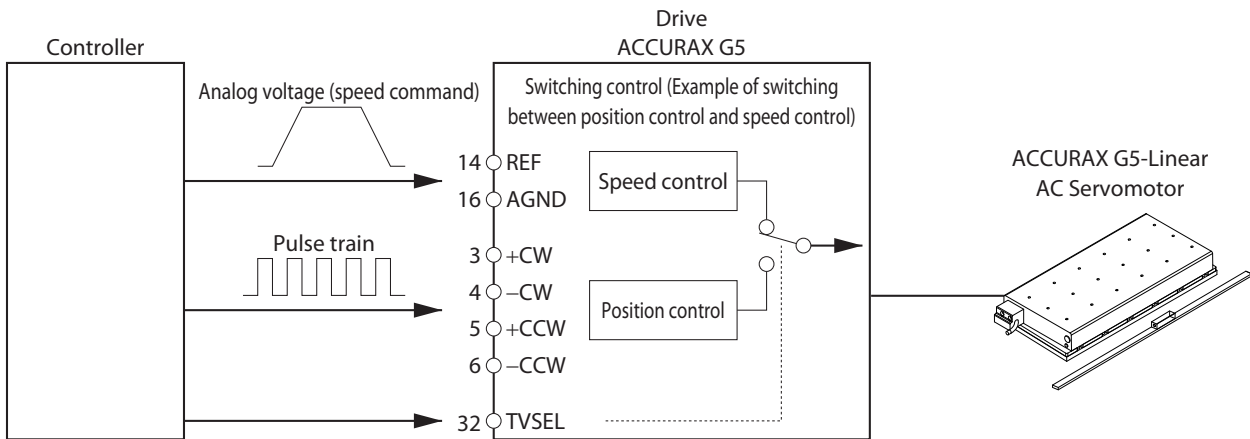

Parameters Requiring Settings

Parameter number	Parameter name	Explanation	Reference
Pn001	CONTROL mode Selection	Select CONTROL mode for switching control. (Set values: 3, 4 and 5)	P.8-2

CONTROL mode Selected by TVSEL (CONTROL mode Switching Input)

- ◆ The following table shows the relation between TVSEL (CONTROL mode switching input) and the CONTROL mode selected.

CONTROL mode Selection (Pn001) setting	TVSEL	
	OFF	ON
3	Position control	Speed control
4	Position control	Force control
5	Speed control	Force control

Note. Use caution when switching CONTROL mode. Operation may change suddenly depending on the CONTROL mode settings.

5 BASIC CONTROL Mode

Operation Example

Position and Speed Control Switching Example (Pn001 = 3)

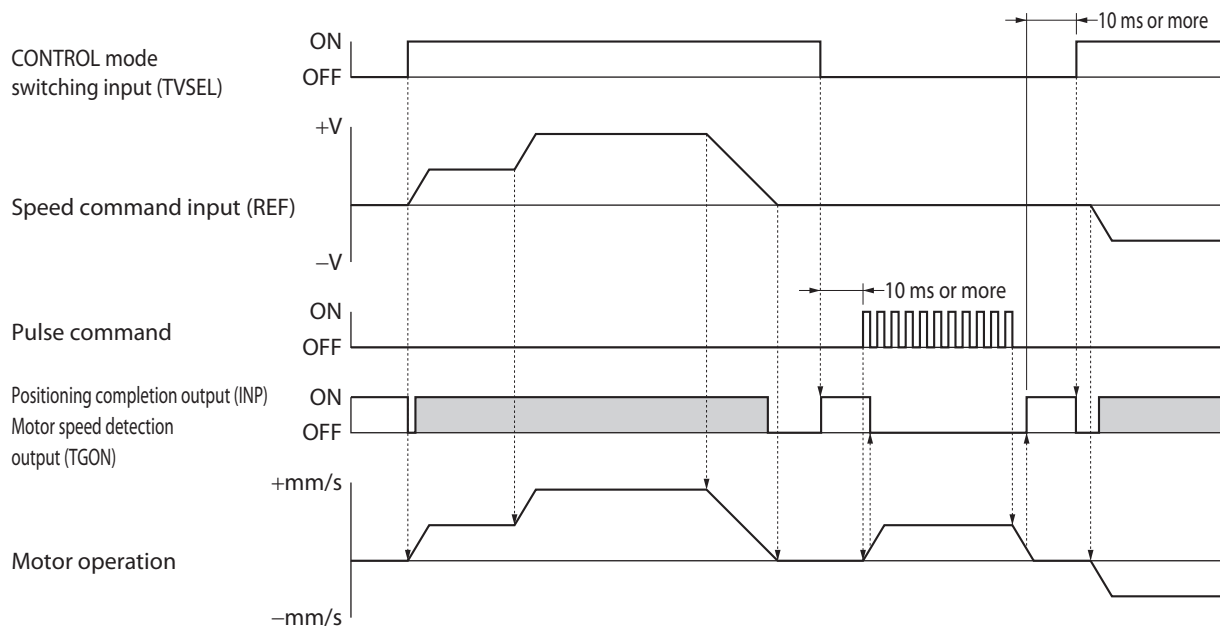

- ♦ There is a maximum delay of 10 ms in reading the input signal.
- ♦ When switching from speed control to position control, turn OFF the CONTROL mode switching input (TVSEL) and wait at least 10 ms after the positioning completion output (INP) turns ON before inputting the pulse command. The pulses input before INP turns ON will be ignored.
- ♦ The shaded areas for the positioning completion output (INP) in the time chart show that the signal is turned ON as the motor speed detection output (TGON). (The meaning of the signal depends on the CONTROL mode.)

Position and Force Control Switching Example (Pn001 = 4)

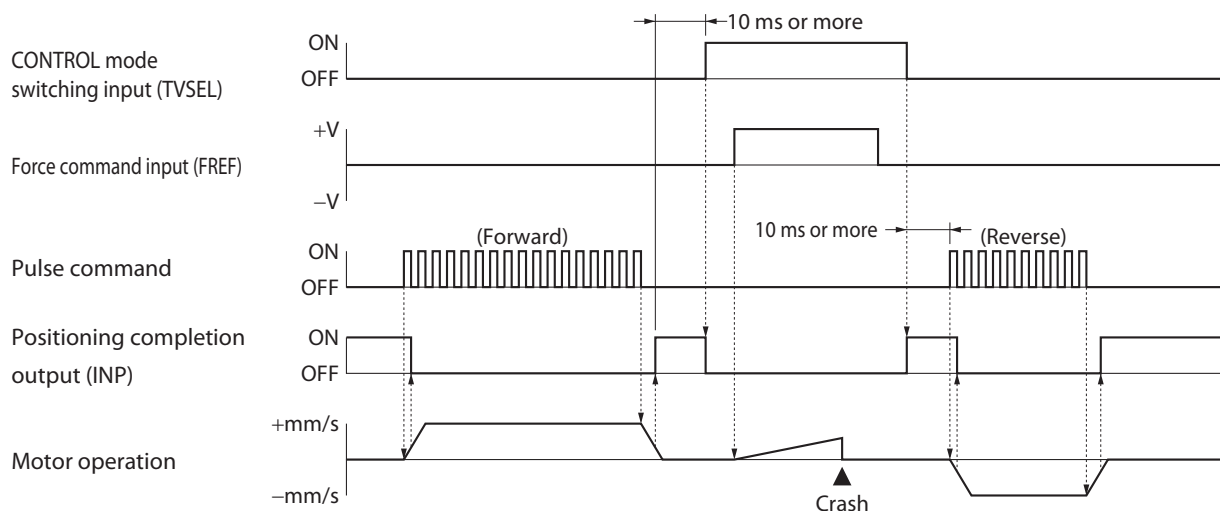

- ♦ This time chart shows an example of force thrust.
- ♦ There is a maximum delay of 10 ms in reading the input signal.
- ♦ When switching from force control to position control, turn OFF the CONTROL mode switching input (TVSEL) and wait at least 10 ms after the positioning completion output (INP) turns ON before inputting the pulse command. The pulses input before INP turns ON will be ignored.

Speed and Force Control Switching Example (Pn001 = 5)

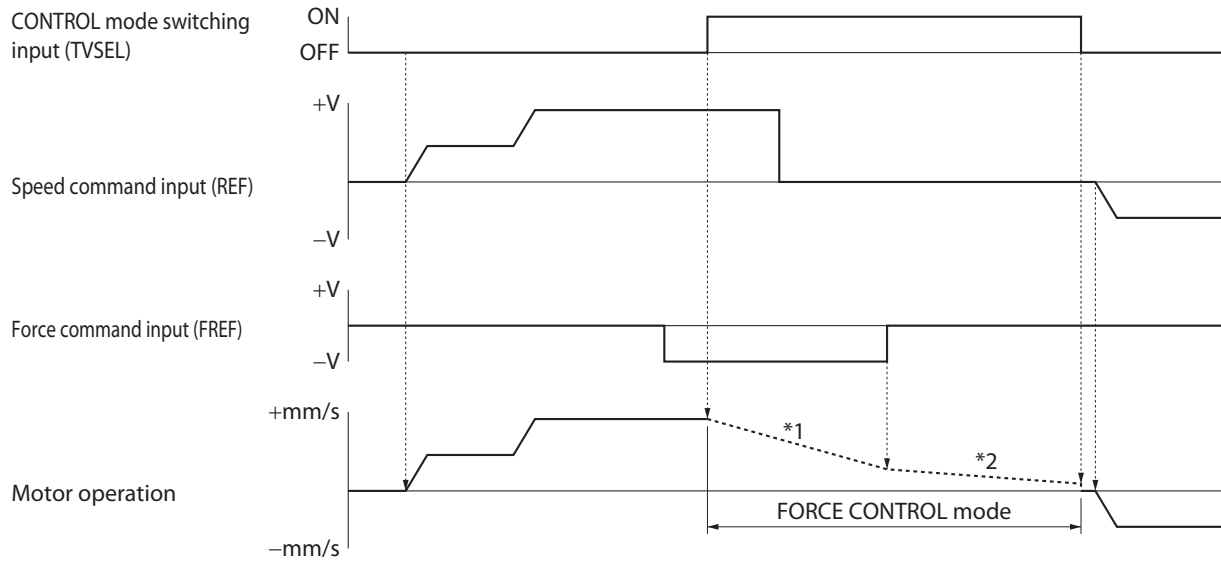

*1. Deceleration for the force command.

*2. Deceleration due to load mass energy and load friction force.

- ♦ There is a maximum delay of 10 ms in reading the input signal.
- ♦ Motor operation in force control changes according to the motor load conditions (e.g., friction, external power, mass). Take safety measures on the machine side to prevent motor runaway.
- ♦ Adjust the force command using Analog Input 2 Offset (Pn425) and Analog Input 2 Filter Time Constant (Pn426) because the force command input is analog input 2.

Related Functions

Refer to the related functions for each CONTROL mode.

6

Applied Functions

This chapter explains different functions such as anti-vibration control, electronic-gear, gain switching and disturbance observer, and explains the contents of settings. Also explains how to setup Linear Servo Motor parameters and encoder.

6-1	Anti-vibration Control	6-3
	Outline of Operation.....	6-3
	Parameters Requiring Settings	6-4
6-2	Adaptive Filter	6-7
	Outline of Operation.....	6-7
	Parameters Requiring Settings	6-8
6-3	Notch Filter	6-9
	Outline of Operation.....	6-9
	Parameters Requiring Settings	6-10
6-4	Electronic Gear Function	6-12
	Outline of Operation.....	6-12
	Parameters Requiring Settings	6-12
	Operation Example	6-13
6-5	Encoder Dividing Function	6-14
	Outline of Operation.....	6-14
	Parameters Requiring Settings	6-14
6-6	Brake Interlock	6-18
	Outline of Operation.....	6-18
	Parameters Requiring Settings.....	6-18
	Precautions for Correct Use of Holding Brake	6-18
	Operation	6-19
6-7	Gain Switching Function	6-23
	Outline of Operation.....	6-23
	Parameters Requiring Settings	6-24
6-8	Gain Switching 3 Function	6-31
	Outline of Operation.....	6-31
	Parameters Requiring Settings	6-31
	Operation	6-31
6-9	Force Limit	6-32
	Outline of Operation.....	6-32
	Parameters Requiring Settings	6-32

6-10 Sequence I/O Signal	6-35
Outline of Operation	6-35
Input Signals	6-35
Output Signals	6-38
6-11 Forward and Reverse Drive Prohibition Functions	6-41
Outline of Operation	6-41
Parameters Requiring Settings	6-41
6-12 Disturbance Observer Function	6-44
Outline of Operation	6-44
Parameters Requiring Settings	6-45
Operating Procedure	6-45
6-13 Friction Force Compensation Function	6-46
Outline of Operation	6-46
Parameters Requiring Settings	6-46
Operation Example	6-47
6-14 Mass Ratio Switching Function	6-48
Outline of Operation	6-48
Parameters Requiring Settings	6-48
Operating Procedure	6-48
6-15 Feed-forward Function	6-49
Outline of Operation	6-49
Parameters Requiring Settings	6-49
Operating Procedure	6-50
6-16 Instantaneous Speed Observer Function	6-53
Outline of Operation	6-53
Parameters Requiring Settings	6-53
Operating Procedure	6-54
6-17 Motor Setup	6-55
Outline of Operation	6-55
Parameters Requiring Settings	6-56
Operating Procedure	6-57
6-18 Encoder Setup	6-58
Outline of Operation	6-58
Parameters Requiring Settings	6-58
Operating Procedure	6-59
6-19 Magnetic Pole Position	6-61
Outline of Operation	6-61
Parameters Requiring Settings	6-61
Operating Procedure	6-62
6-20 Setup with Serial Converter	6-64
Outline of Operation	6-64
Parameters Requiring Settings	6-64
Operating Procedure	6-65

6-1 Anti-vibration Control

Outline of Operation

If the tip of the mechanical unit vibrates, you can use the anti-vibration control function to reduce vibration.

This is effective on vibration generated by a machine of low rigidity. The applicable frequencies are from 1 to 200 Hz.

Since anti-vibration control is performed using position commands, it cannot be used with speed or force control.

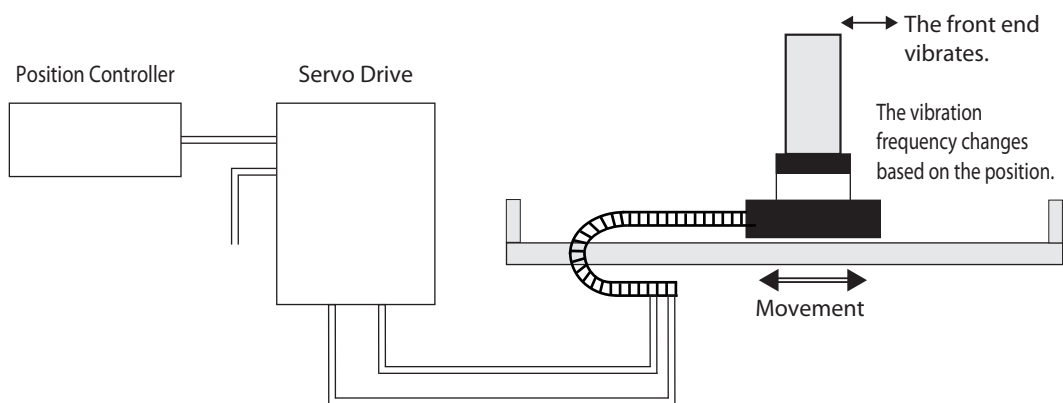

Parameters Requiring Settings

Parameter number	Parameter name	Explanation	Reference
Pn001	CONTROL mode Selection	Set to the POSITION mode. 0: Position control 3: FIRST CONTROL mode for position/speed control 4: FIRST CONTROL mode for position/force control	P.8-2
Pn213	Vibration Filter Selection	Select the VIBRATION FILTER SWITCHING mode according to the condition of the unit. 0: Vibration filter 1 or 2 enabled 1: Switching by external input (DFSEL1) 2: Switching by external input (DFSEL1, DFSEL2) 3: Switching with command direction	P.8-22
Pn214	Vibration Frequency 1	Set vibration frequency 1 to suppress vibration at the end of the load in anti-vibration control. If the anti-vibration control function is not used, set 0.	P.8-22
Pn215	Vibration Filter 1 Setting	When the Vibration Frequency 1 (Pn214) is set, reduce the setting if force saturation occurs or increase the setting to increase operation speed. Normally 0 is set. If the vibration filter 1 is disabled, this parameter is also disabled.	P.8-22
Pn216	Vibration Frequency 2	The function is the same with Pn214.	P.8-22
Pn217	Vibration Filter 2 Setting	The function is the same with Pn215.	P.8-22
Pn218	Vibration Frequency 3	The function is the same with Pn214.	P.8-23
Pn219	Vibration Filter 3 Setting	The function is the same with Pn215.	P.8-23
Pn220	Vibration Frequency 4	The function is the same with Pn214.	P.8-23
Pn221	Vibration Filter 4 Setting	The function is the same with Pn215.	P.8-23



Precautions for Correct Use

- ◆ Stop operation before changing the parameters or switching with DFSEL.
- ◆ It may not function properly or the effect may not be apparent under the following conditions.

Item	Conditions under which the effect of anti-vibration control is inhibited
CONTROL mode	- SPEED or FORCE CONTROL mode
Load condition	- If forces other than position commands, such as external forces, cause vibration. - If the vibration frequency is outside the range of 1 to 200 Hz. - If the ratio of the resonance frequency to anti-resonance frequency is large.

Operating Procedure

1. Adjust the position loop gain and speed loop gain.

Adjust Position Loop Gain (Pn100), Speed Loop Gain (Pn101), Speed Loop Integral Time Constant (Pn102) and Force Command Filter Time Constant (Pn104).

If no problem occurs in realtime autotuning, you can continue to use the settings.

2. Measure the vibration frequency at the tip of the mechanical unit.

Measure the vibration frequency using a laser displacement sensor, servo acceleration meter, acceleration pick-up, etc.

Set the vibration frequency in one of Vibration Frequency 1 to Vibration Frequency 4 (1: Pn214, 2: Pn216, 3: Pn218, 4: Pn220) according to the operation.

Also set the SWITCHING mode using Vibration Filter Selection (Pn213).

If the measurement device cannot be used, use CX-Drive tracing function, and read the residual vibration frequency (Hz) from the position error waveform as shown in the following figure.

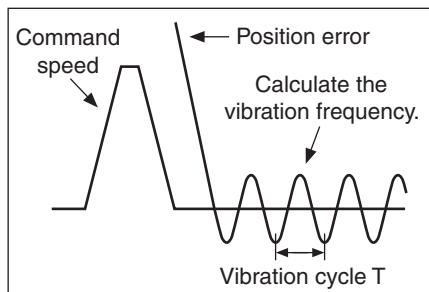

• The following gives the vibration frequency in the figure.

$$f \text{ (Hz)} = \frac{1}{T \text{ (s)}}$$

Since the parameter unit is 0.1 Hz:

(Pn214, Pn216, Pn218, Pn220) = 10 × f

• Application example

If the vibration cycle is 100 ms or 20 ms, set 100 or 500 in the parameter so that the vibration frequency becomes 10 Hz or 50 Hz.

If vibration persists after setting the frequency, increase or decrease the filter frequency to find the frequency at which vibration decreases.

3. Set vibration filter setting.

Set vibration filter setting (1: Pn215, 2: Pn217, 3: Pn219, 4: Pn221).

First, set to 0.

The stabilization time can be reduced by setting a large value; however, force ripple will increase at the command change point as shown in the following figure. Set a range that will not cause force saturation under actual operation conditions. The effects of vibration suppression will be lost if force saturation occurs.

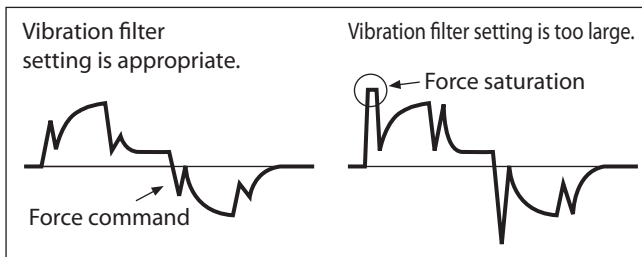

When the Vibration Frequency 1 (Pn214) is set, reduce the setting if force saturation occurs or increase the setting to increase operation speed. Normally 0 is set.

If the vibration filter 1 is enabled, use the following setting range.

Setting range: $100 \leq \text{Pn214} + \text{Pn215} \leq \text{Pn214} \times 2$ or 2,000

Note: If the vibration filter 1 is disabled under Vibration Filter Selection (Pn213), this parameter is also disabled.

4. Set the Vibration Filter Selection (Pn213).

Vibration filters 1 to 4 can be switched according to the conditions of the machine vibration.

Set value	SWITCHING mode
0	Vibration filter 1 and 2 enabled
1	Switching by external input (DFSEL1) Open: Vibration filter 1 or 3 enabled Shorted: Vibration filter 2 or 4 enabled
2	Switching by external input (DFSEL1, DFSEL2) When DFSEL1 and DFSEL2 are both open: Vibration filter 1 enabled When DFSEL1 is shorted and DFSEL2 is open: Vibration filter 2 enabled When DFSEL1 is open and DFSEL2 is shorted: Vibration filter 3 enabled When DFSEL1 and DFSEL2 are both shorted: Vibration filter 4 enabled
3	Switching with command direction Forward direction: Vibration filter 1 or 3 enabled Reverse direction: Vibration filter 2 or 4 enabled

Vibration Filter Selection (Pn213) is a parameter that becomes effective when the power is turned on. After setting this parameter, turn OFF the control power supply and then turn it ON again.

6-2 Adaptive Filter

Outline of Operation

The adaptive filter reduces resonance point vibration by estimating the resonance frequency from the vibration component that appears in the motor speed during actual operation and automatically sets the frequency of the notch filter, which removes the resonance component from the force command.

The automatically set notch filter frequency is set in Notch 3 (Pn207 to Pn209) or Notch 4 (Pn210 to Pn212).

Refer to P.6-9 for information on notch filter.

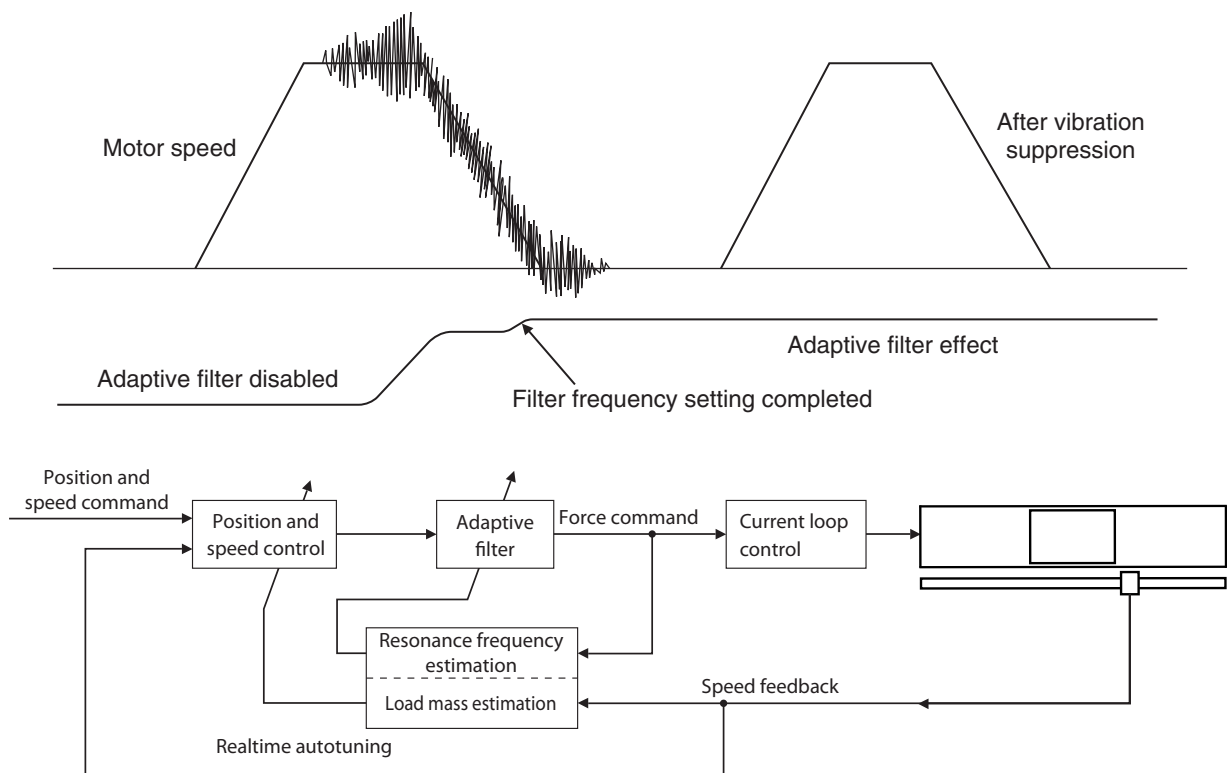

Parameters Requiring Settings

Parameter number	Parameter name	Explanation	Reference
Pn200	Adaptive Filter Selection	<p>Set the number of resonance frequencies to be estimated by the adaptive filter and the operation to be performed after estimation.</p> <p>0: Adaptive filter disabled 1: 1 adaptive filters enabled 2: 2 adaptive filters enabled 3: resonance frequency measurement mode The servodrive measures the resonant frequency automatically but the result is applied by the user by using the software tool (CX-Drive). 4: Adaptive result clear The notch filter 3 and notch filter 4 parameters are disabled, and adaptive result is cleared.</p>	P.8-20



Precautions for Correct Use

- ♦ Adaptive filter may not operate correctly under the following conditions.

Item	Conditions under which the adaptive filter not operates properly
CONTROL mode	<ul style="list-style-type: none"> · FORCE CONTROL mode
Resonance points	<ul style="list-style-type: none"> · If the resonance frequency is 300 Hz or lower. · If the resonance peak or control gain is low, and the motor speed is not affected by it. · If there are three or more resonance points.
Load	<ul style="list-style-type: none"> · If the motor speed with high-frequency components changes due to low rigidity or other non-linear elements.
Command pattern	<ul style="list-style-type: none"> · The acceleration/deceleration is sudden.

- ♦ If the adaptive filter does not operate properly, use Notch 1 (Pn201 to Pn203) or Notch 2 (Pn204 to Pn206) to implement resonance measures according to the manual adjustment procedure. Refer to P.6-9 for information on notch filter.
- ♦ An unusual noise or vibration may occur until the adaptive filter stabilizes after startup, immediately after the first servo ON, or when the Realtime Autotuning Machine Rigidity Selection (Pn003) is increased, but this is not a problem if it disappears right away. If the vibration or unusual noise, however, continues for three or more reciprocating operations, take the following measures in the possible order.
 - Write the parameters used during normal operation to the EEPROM.
 - Lower the Realtime Autotuning Machine Rigidity Selection (Pn003).
 - Disable the adaptive filter by setting the Adaptive Filter Selection (Pn200) to 0. (Resetting of mass estimation and adaptive operation)
 - Manually set the notch filter.
- ♦ If unusual noise or vibration occurred, the setting of Notch 3 (Pn207 to Pn209) or Notch 4 (Pn210 to Pn212) may have changed to an extreme value. In this case, set Adaptive Filter Selection (Pn200) to 0 to disable the parameter and then set Notch 3 Frequency Setting (Pn207) and Notch 4 Frequency Setting (Pn210) to 5,000 (disabled). Next, enable Adaptive Filter Selection again.
- ♦ Notch 3 Frequency Setting (Pn207) and Notch 4 Frequency Setting (Pn210) are written to the EEPROM every 30 minutes. When the power supply is turned OFF and then turned ON again, this data will be used as the default settings to perform adaptive operation.
- ♦ The adaptive filter is disabled when force control is performed, but the adaptive filter frequency used in the CONTROL mode before switching will be held if force control has been selected by setting the CONTROL mode Selection (Pn001) to 5 or 6.

6-3 Notch Filter

Outline of Operation

You can set up to 4 notch filters for the force command.

If the mechanics cause resonance at the specific location, you can set the resonance frequency using a notch filter to eliminate resonance.

A notch filter is used to eliminate a specified frequency component.

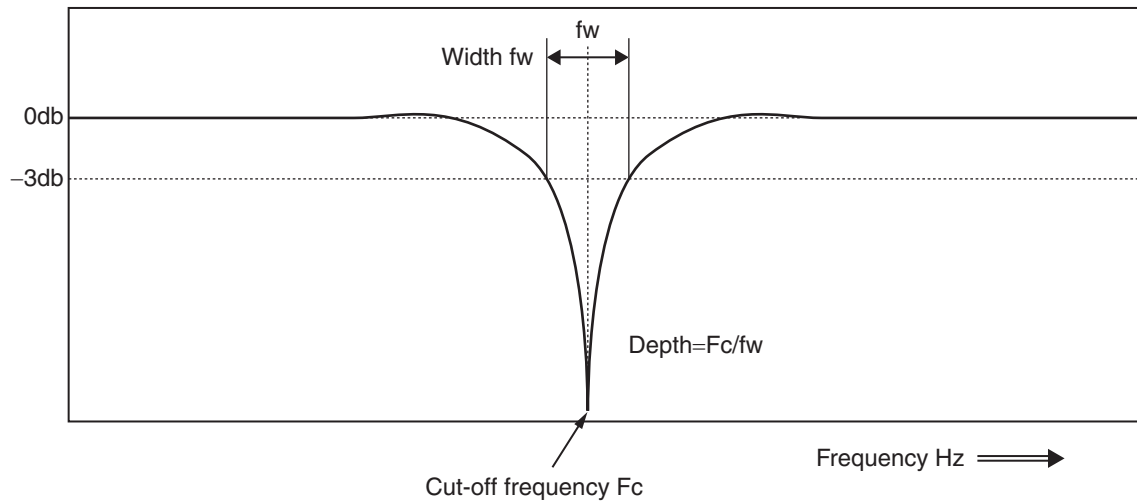

If machine resonance occurs, use this notch filter to eliminate resonance.

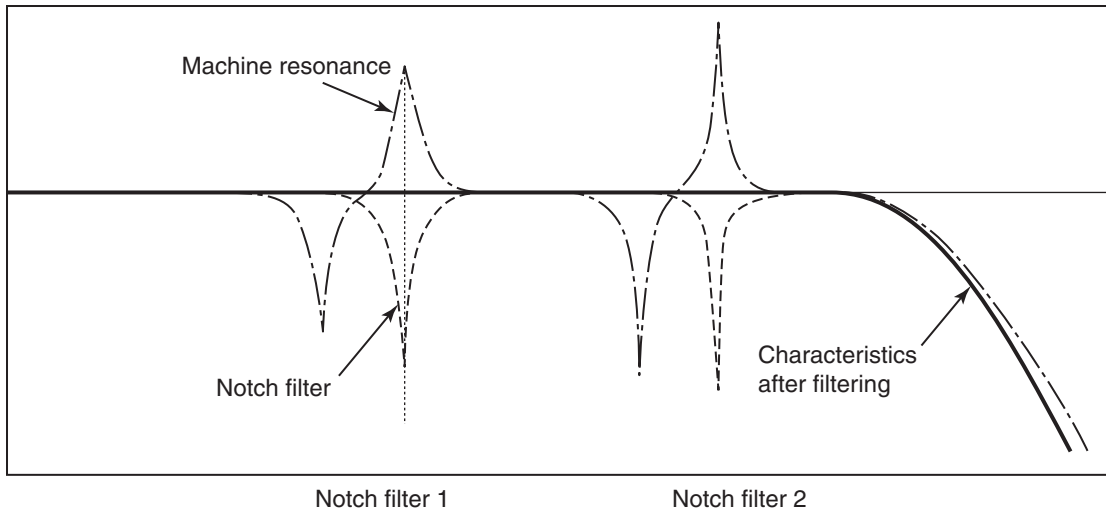

Parameters Requiring Settings

Parameter number	Parameter name	Explanation	Reference
Pn201	Notch 1 Frequency Setting	Set the center frequency of the notch filter 1. The notch filter is enabled at 50 to 4,999 Hz, and disabled at 5,000 Hz.	P.8-20
Pn202	Notch 1 Width Setting	Select the width of the notch filter 1 frequency. Increasing the value will widen the notch. (Setting range: 0 to 20)	P.8-20
Pn203	Notch 1 Depth Setting	Select the depth of the notch filter 1 center frequency. Increasing the value will decrease the notch depth and thereby reduce the phase delay. The notch filter is disabled if 100 is set. (Setting range: 0 to 99)	P.8-20
Pn204	Notch 2 Frequency Setting	Set the center frequency of the notch filter 2. The details are the same with the notch filter 1 frequency.	P.8-20
Pn205	Notch 2 Width Setting	Select the width of the notch filter 2 frequency. The details are the same with the notch filter 1 width.	P.8-20
Pn206	Notch 2 Depth Setting	Select the depth of the notch filter 2 center frequency. The details are the same with the notch filter 1 depth.	P.8-21
Pn207	Notch 3 Frequency Setting *1	Set the center frequency of the notch filter 3. The details are the same with the notch filter 1 frequency.	P.8-21
Pn208	Notch 3 Width Setting *1	Select the width of the notch filter 3 frequency. The details are the same with the notch filter 1 width.	P.8-21
Pn209	Notch 3 Depth Setting *1	Select the depth of the notch filter 3 center frequency. The details are the same with the notch filter 1 depth.	P.8-21
Pn210	Notch 4 Frequency Setting *1	Set the center frequency of the notch filter 4. The details are the same with the notch filter 1 frequency.	P.8-21
Pn211	Notch 4 Width Setting *1	Select the width of the notch filter 4 frequency. The details are the same with the notch filter 1 width.	P.8-21
Pn212	Notch 4 Depth Setting *1	Select the depth of the notch filter 4 center frequency. The details are the same with the notch filter 1 depth.	P.8-21

*1 If an adaptive filter is used, these are set automatically.



Precautions for Correct Use

- ◆ Identify the resonance frequency using the frequency characteristics measurement function, resonance frequency monitor or operation waveform of the waveform graphics function of CX-Drive and set the identified frequency as the notch filter frequency.

Notch Filter Width and Depth

Width Setting

Ratio of the frequency bandwidth at a damping factor of -3 [dB] relative to the center frequency when the depth is 0. This value should conform to the left column in the table below.

Depth Setting

I/O ratio at which the center frequency input is completely cut off at a set value of 0 and completely passed at a set value of 100. If the indication unit is [dB], this value should conform to the right column in the table below.

Width	
Set value	Bandwidth/center frequency
0	0.50
1	0.59
2	0.71
3	0.84
4	1.00
5	1.19
6	1.41
7	1.68
8	2.00
9	2.38
10	2.83
11	3.36
12	4.00
13	4.76
14	5.66
15	6.73
16	8.00
17	9.51
18	11.31
19	13.45
20	16.00

Depth		
Set value	I/O ratio (%)	Damping factor (dB)
0	0 (Cut off)	$-\infty$
1	1	-40.0
2	2	-34.0
3	3	-30.5
4	4	-28.0
5	5	-26.0
10	10	-20.0
15	15	-16.5
20	20	-14.0
25	25	-12.0
30	30	-10.5
35	35	-9.1
40	40	-8.0
45	45	-6.9
50	50	-6.0
60	60	-4.4
70	70	-3.1
80	80	-1.9
90	90	-0.9
100	100 (Passed)	0.0

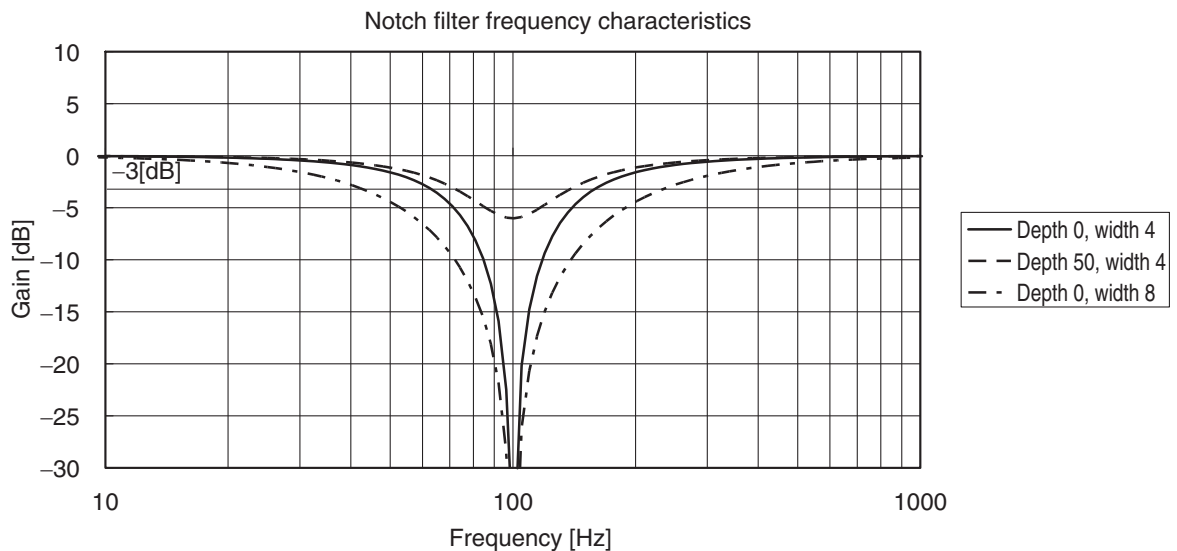

6-4 Electronic Gear Function

Outline of Operation

- ♦ The motor can be moved for the number of pulses obtained by multiplying the position command values by the electronic ratio.
- ♦ This function is enabled only in position control mode.

Parameters Requiring Settings

Parameter number	Parameter name	Explanation	Reference
Pn009	Electronic Ratio Numerator 1	Set the numerator of the electronic ratio.	P.8-6
Pn010	Electronic Ratio Denominator	Set the denominator of the electronic ratio.	
Pn500	Electronic Ratio Numerator 2 *1	Set the numerator of the electronic ratio 2.	
Pn501	Electronic Ratio Numerator 3 *1	Set the numerator of the electronic ratio 3.	
Pn502	Electronic Ratio Numerator 4 *1	Set the numerator of the electronic ratio 4.	

*1. Switching among Electronic Ratio Numerators 2 to 4 (Pn500 to Pn502) is performed using the electronic switching input (GESEL1/GESEL2).

The settings of GESEL1 and GESEL2 are as follows.

GESEL1	GESEL2	Applicable parameters
OFF	OFF	Electronic Ratio Numerator 1 (Pn009)
ON	OFF	Electronic Ratio Numerator 2 (Pn500)
OFF	ON	Electronic Ratio Numerator 3 (Pn501)
ON	ON	Electronic Ratio Numerator 4 (Pn502)

Note: The resolution of the encoder must be properly set in Pn901.

Electronic Ratio Setting (Pn009, Pn010)

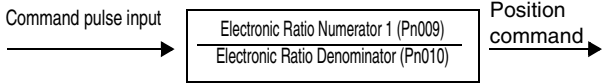
Electronic Ratio Numerator 1 (Pn009)	Electronic Ratio Denominator (Pn010)	Explanation
1 to 1073741824	1 to 1073741824	<p>The processing will be based on the set values of Electronic Ratio Numerator 1 (Pn009) and Electronic Ratio Denominator (Pn010).</p> <div style="text-align: center;">  </div> <p>Position command pulse = Electronic Ratio Numerator 1 (Pn009) / Electronic Ratio Denominator (Pn010)</p>

Operation Example

- Example of a motor with a resolution of 40µm/pulse (so, 10µm/count)
- If you set Pn009=100 and Pn010=40 the command unit will correspond to 100µm/command pulse.

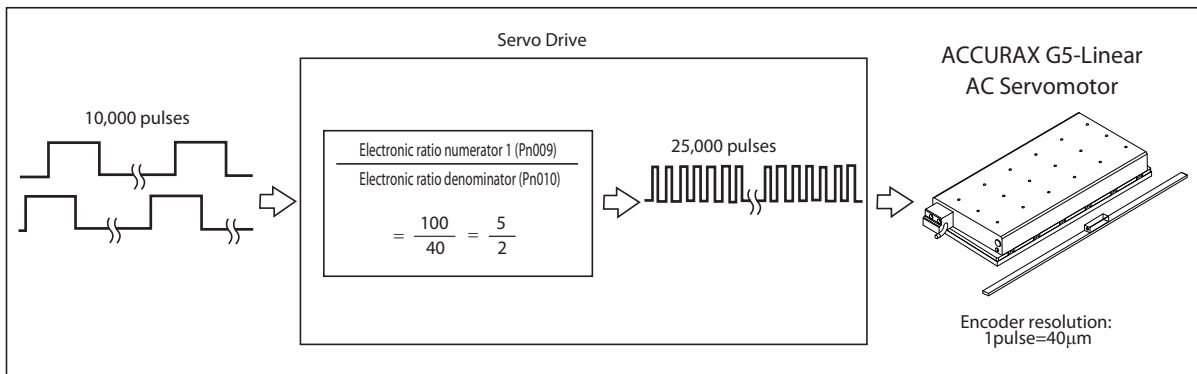

- In the linear encoder 1 pulse correspond with 4 counts (so, the real resolution is 10µm).
- In the command, the meaning of pulse may differ according to the pulse command type (Pn007). For Pn007=0 or 2, one pulse also has 4 counts, for the other modes, one pulse has only 2 counts.

6-5 Encoder Dividing Function

Outline of Operation

- ♦ The number of output pulses from the drive can be adjusted.
- ♦ You can set the number of output pulses per motor movement distance.
- ♦ This function is used in the following cases:
 - When you use a controller with a low response frequency
 - When you want to set the pulse rate corresponding to a certain value

Parameters Requiring Settings

Parameter number	Parameter name	Explanation	Reference
Pn011	Encoder Dividing Numerator	Set the number of A/B output pulses for every Pn503 number of encoder pulses.	P.8-7
Pn012	Encoder Output Direction Switching Selection	Select the phase B logic for pulse regeneration output and the output source.	P.8-7
Pn503	Encoder Dividing Denominator	Number of encoder pulses to output Pn011 regenerated output pulses. With the default setting 1 encoder pulse correspond with 1 output pulse.	P.8-45
Pn533	Pulse Regeneration Output Limit Setting	Set whether to enable or disable the detection of Err28.0 "pulse regeneration error." 0: Disabled, 1: Enabled	P.8-56
Pn620	External Scale Phase-Z Setting	Set the minimum external scale phase-Z output width.	P.8-59
Pn621	Serial Absolute External Scale Phase-Z Setting	Set the phase-Z regeneration position when the serial absolute external scale is used. 0: Phase-Z output only at a position where the absolute position is 0 1 to 2 ²⁸ : After a phase-Z output at the position where the absolute position is 0, phase Z is output every the set value pulse cycle. No phase-Z is output until passing absolute position 0	P.8-59
Pn622	Phase AB External Scale Pulse Output Method Selection	Select the regeneration method of pulse outputs OA and OB when an external scale of phase AB-output type is used. 0: Without signal regeneration. Z-out is directly Z-in in the scale 1: With signal regeneration	P.8-60

Encoder Dividing Ratio Setting (Pn011, Pn503)

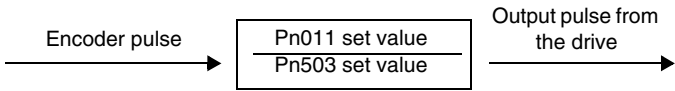
Encoder Dividing Numerator (Pn011)	Encoder Dividing Denominator (Pn503)	Explanation
1 to 262144	1 to 262144	<p>The output pulse will be as follows based on Encoder Dividing Numerator (Pn011) and Encoder Dividing Denominator (Pn503).</p>  <p style="text-align: center;">Encoder pulse → Pn011 set value Pn503 set value → Output pulse from the drive</p>

*If the motor Encoder has 40μm/pulse and we want 10pulses/mm output resolution we have to set Pn011/Pn503=10/25.

Encoder Output Direction Switching Selection (Pn012)

The corresponding scale for each output type is as follows.

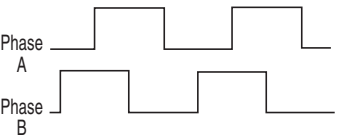
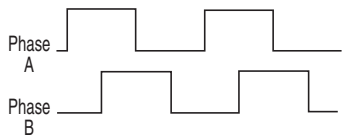
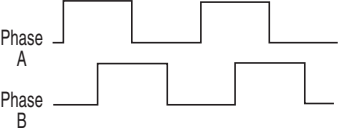
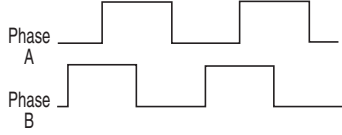
Encoder Output Direction Switching Selection (Pn012)	Phase B logic	For forward direction operation	For reverse direction operation
0, 2	Non-reverse		
1, 3	Reverse		

Encoder Z Pulse Regeneration Function

Serial Absolute Encoder

Phase Z is output only after the control power supply for amplifier is turned ON and when it crosses the zero absolute position of the encoder. Based on this position, phase Z is output at the intervals of phase-A pulse that is set to Pn621. However, if Pn621 = 0, phase Z is output only at the zero absolute position.

Serial Incremental Encoder

Phase Z is output without dividing the phase Z of the serial incremental encoder. In addition, take note that there are differences as illustrated in the figure below depending on the direction passing phase Z.

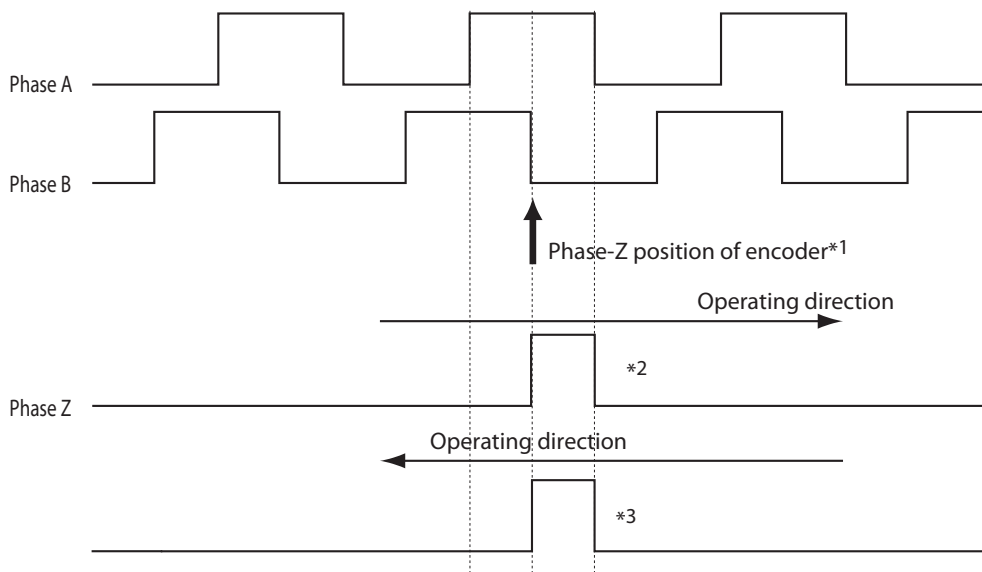

- *1. Phase-Z position and its relationship with phases A and B vary depending on the scale.
- *2. Phase Z is regenerated for 1 pulse. If the width is narrow, the output time can be extended by the Encoder Phase Z Setting (Pn620).
- *3. If the Encoder feedback frequency is higher than 15Mpulses/s, the Z pulse cannot be regenerated properly. Do not exceed this frequency if Z pulse is used for control purposes.

ABZ Encoder

- ♦ Phase Z is output without dividing the Z signal that is input from the ABZ Encoder.
- ♦ When the Phase-AB Encoder Pulse Output Method Selection (Pn622) = 1, the phase-AB signal can be loaded to the amplifier and regenerated. Note, in this case, that the phase-AB regeneration will be delayed compared to when Pn622 is set to 0.

Encoder Common Items

- ♦ When detection cannot be made because the phase-Z signal width is narrow due to the Encoder travel distance, if you set the phase-Z signal output time in the Encoder-Z Setting (Pn620), phase Z can be output at least for that period of time. In addition, take note that the output is made from when the phase-Z signal starts and, therefore, it will be different from the actual phase-Z signal width. Take note, also, that the direction of the time extension varies depending on the direction of the operation.

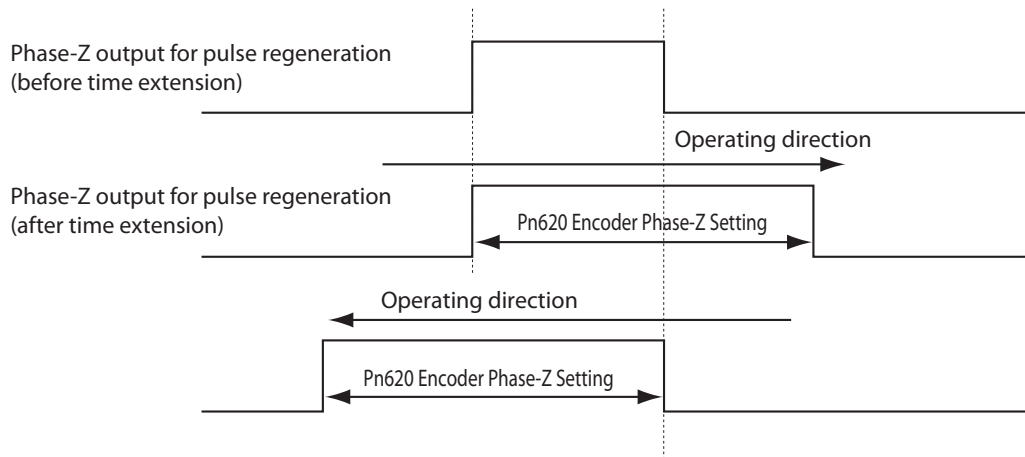

Precautions for Correct Use

- ♦ The maximum output frequency of the pulse regeneration output will be 4 Mpps (after quadruple multiplier). If operated at a speed that exceeds this, the regeneration function may not operate properly and position misalignment may result.

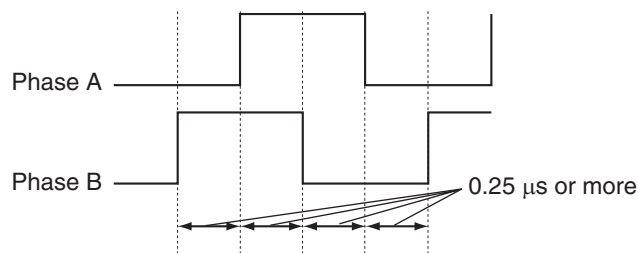

- You can generate Err28.0 "pulse regeneration error" when the pulse regeneration limit is reached based on the Pulse Regeneration Output Limit Setting (Pn533). Note that this error is generated when the pulse regeneration output limit is detected. Therefore, the error does not occur due to the maximum output frequency. Depending on the motor movement status, the error may occur when the detection is made at the frequency that goes up momentarily.

6-6 Brake Interlock

Outline of Operation

- ♦ This function lets you set the output timing for the brake interlock (BKIR) signal that activates the holding brake when the servo is turned ON, an alarm generates, or the servo is turned OFF.
- ♦ Contrary to the rotary motors, the brake in the linear motor is an external element that must be supplied separately and installed by the user.

Parameters Requiring Settings

Parameter number	Parameter name	Explanation	Reference
Pn437	Brake Timing when Stopped	Set the time after a servo OFF command is issued upon servo lock stop, until the brake interlock (BKIR) signal turns OFF and power supply stops.	P.8-43
Pn438	Brake Timing during Operation	Set the time after a servo OFF command is issued while the motor is moving, until the brake interlock (BKIR) signal turns OFF and power supply stops. If the speed drops to 30 mm/s or below before the time set here, BKIR will turn OFF.	P.8-43
Pn439	Brake clear speed setting	To set the speed threshold for run time mechanical brake output determination	P.8-43

Precautions for Correct Use of Holding Brake

- ♦ The brake on a linear slider with brake is expected to be a normally closed brake designed only to hold when stopped.
Accordingly, set an appropriate time so that the brake will actuate after the motor stops.
- ♦ If the brake is applied while the linear servomotor is moving, the brake will wear abnormally or sustain damage, resulting in failure in the linear motor system.

Operation

Servo ON/OFF Operation Timings <when Motor Is Stopped>

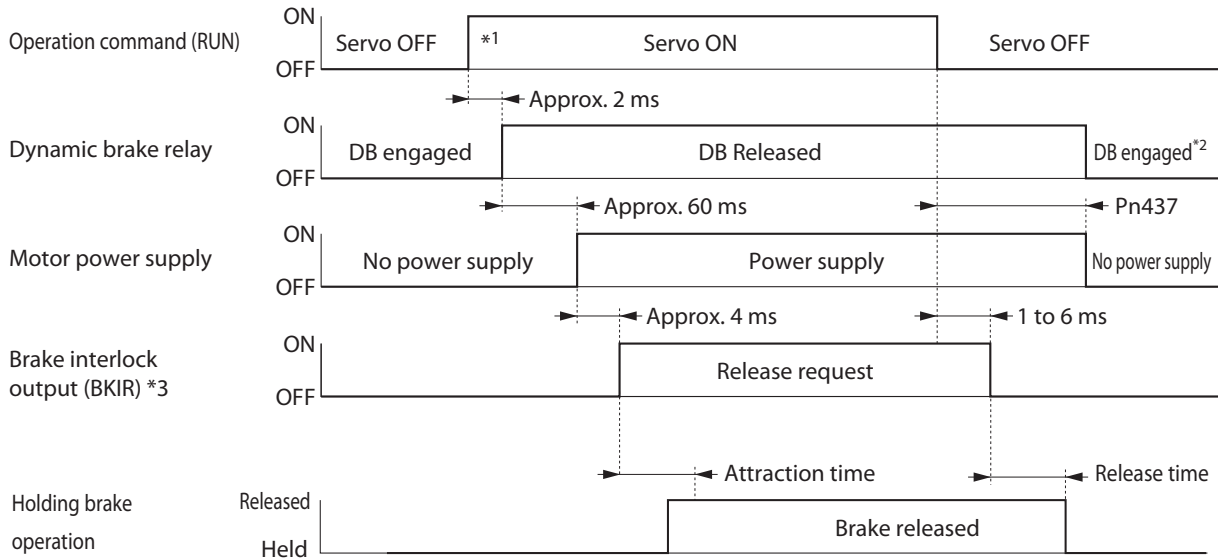

*1. The servo will not turn ON until the motor speed drops to approx. 30 mm/s or below.

*2. The dynamic brake operation when the servo is OFF depends on Stop Selection with Servo OFF (Pn506).

*3. The brake interlock (BKIR) signal is output upon a release request from servo control. The BKIR signal is allocated to a CN1 general-purpose output to be used.

Note: The brake attraction time and release time vary depending on the brake. For details, refer to the brake specification.

Servo ON/OFF Operation Timings <When Motor Is Moving>

Based on these operation timings, regenerative energy is produced if the motor movement stops abnormally.

Accordingly, repeated operations cannot be performed.

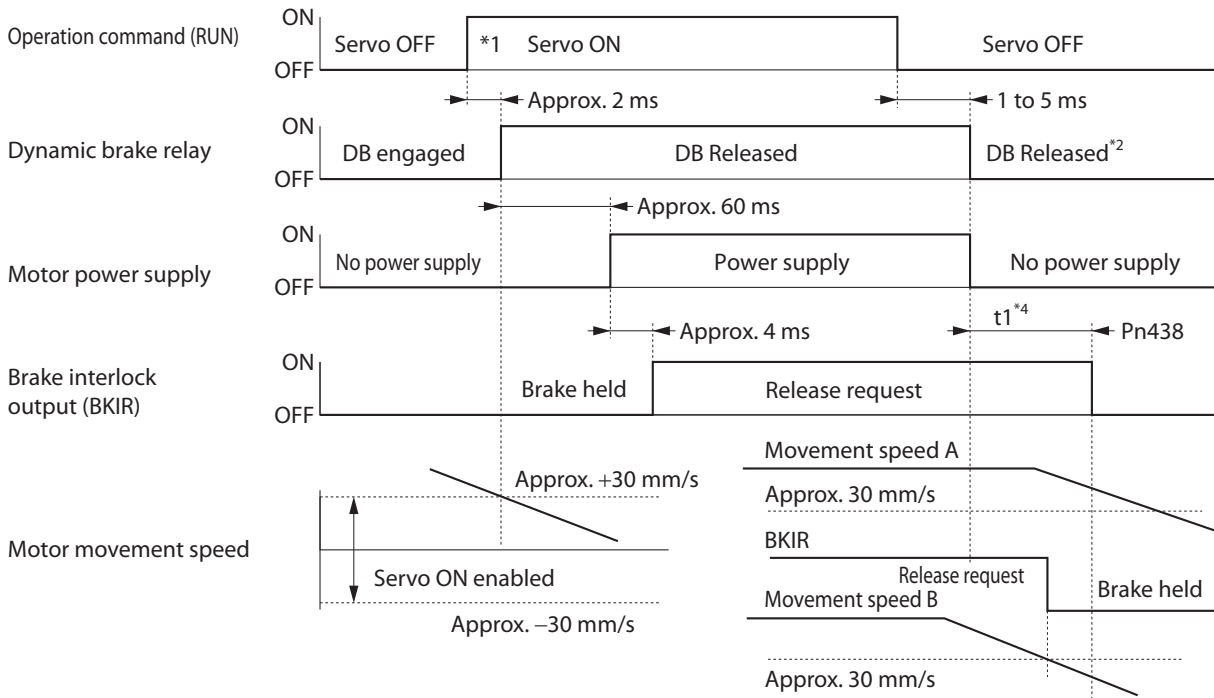

- *1. The servo will not turn ON until the motor speed drops to approx. 30 mm/s or below.
- *2. The dynamic brake operation when the servo is OFF depends on Stop Selection with Servo OFF (Pn506).
- *3. The brake interlock (BKIR) signal is output upon a release request from servo control. The BKIR signal is allocated to a CN1 general-purpose output to be used.
In the above example, no release request is received from the network.
- *4. t1 is the set value of Brake Timing during Operation (Pn438), or the time needed for the motor speed to drop to 30 mm/s or below, whichever occurs first.

Note: Even when the servo ON input is turned ON again while the motor is decelerating, the system will not enter the servo ON state until the motor stops.

Operation Timings when Alarm Generates (Servo ON)

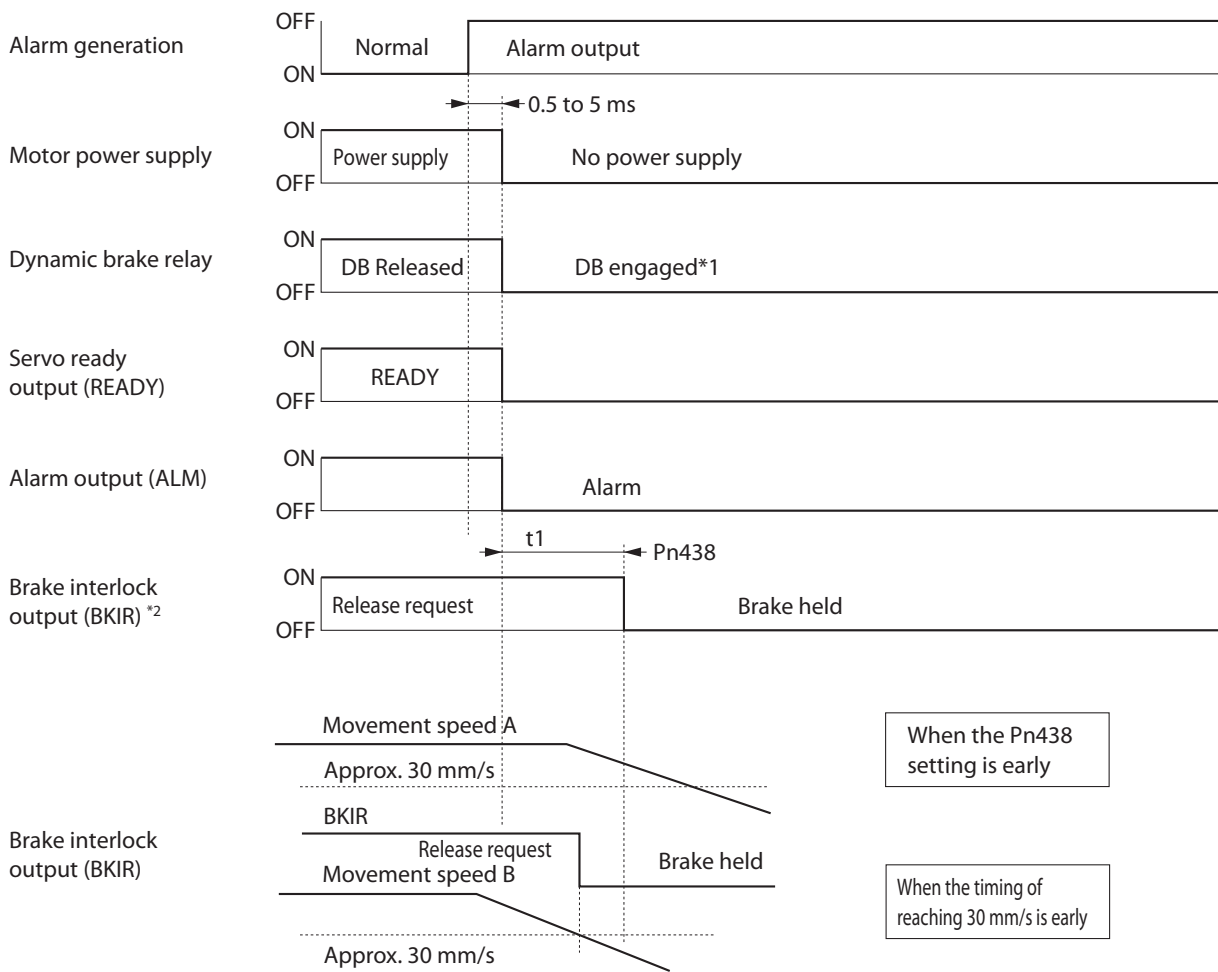

*1. The dynamic brake operation when an alarm generates depends on Stop Selection with Servo OFF (Pn506).
 *2. t_1 is the set value of Brake Timing during Operation (Pn438), or the time needed for the motor speed to drop to 30 mm/s or below, whichever occurs first.

Note 1. Even when the servo ON input is turned ON again while the motor is decelerating, the system will not enter the servo ON state until the motor stops. The brake interlock (BKIR) signal is allocated to a CN1 general-purpose output to be used.

Note 2. If the main circuit power supply turns OFF while the motor is operating, a phase loss alarm or main circuit voltage low alarm will occur, in which case this operation timing will be applied.

Operation Timings at Alarm Reset

Reset alarms by turning OFF the power supply and then turning it ON again. The alarm reset input recognition time can be changed using Alarm Reset Condition Selection (Pn516). The default setting is 120 ms.

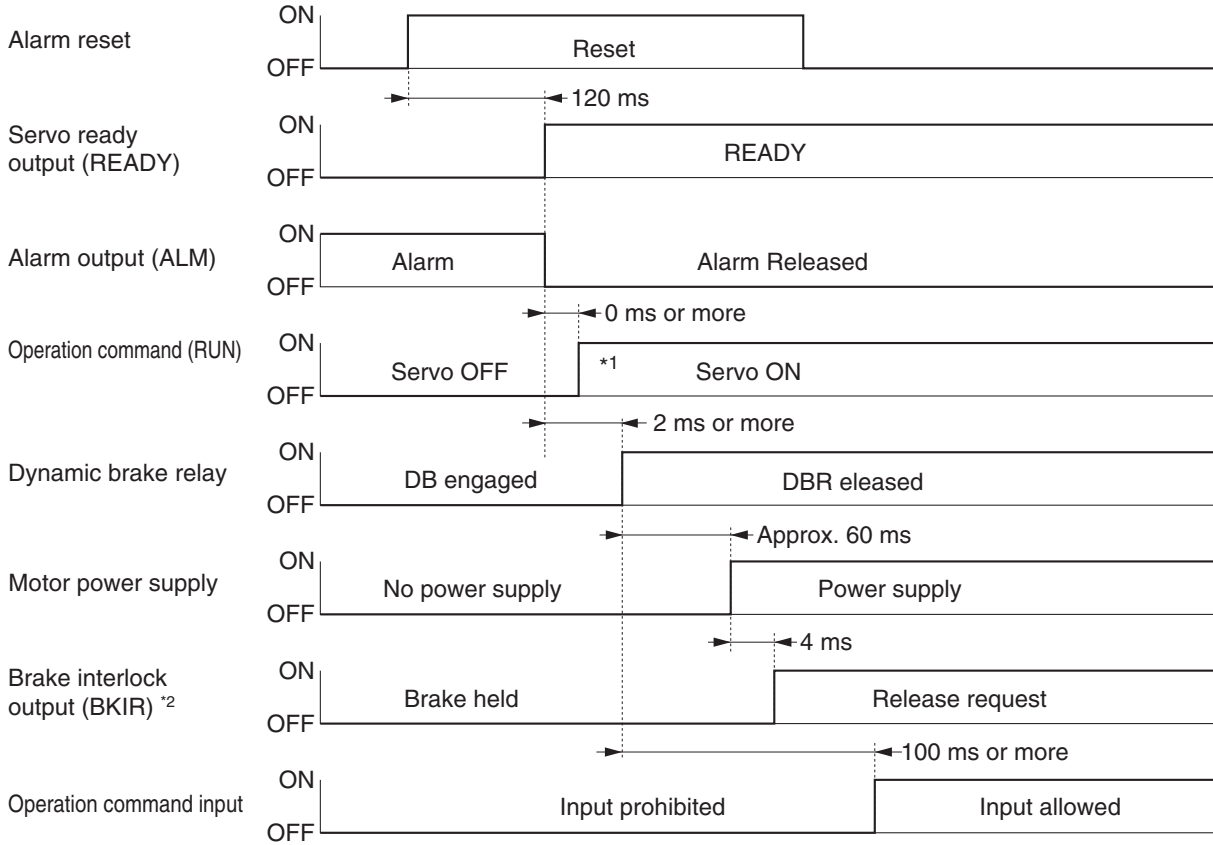

*1. The servo will not turn ON until the motor speed drops to approx. 30 mm/s or below.

*2. The brake interlock (BKIR) signal is output upon a release request from servo control. The BKIR signal is allocated to a CN1 general-purpose output to be used.

Note: After the alarm has been reset, the system enters the servo OFF state (motor not excited). To turn the servo ON, issue a servo ON command again after resetting the alarm, according to the above timings.

6-7 Gain Switching Function

Outline of Operation

- This function switches the position loop and speed loop gain.
- Select enable or disable using GAIN SWITCHING INPUT OPERATING mode Selection (Pn114). Set the switching condition using gain switching setting.
- If the load mass changes or you want to change the responsiveness depending on whether the motor is stopping and operating, you can perform an optimal control by gain switching.
- Use gain switching when the realtime autotuning does not operate effectively, etc. (see below.)
 - When the load mass fluctuates in 200 ms or less.
 - When the motor speed does not exceed 500 mm/s, or load force does not exceed 50% of the rated force.
 - When external force is constantly applied, as with a vertical axis.

Note. When the gain 2 has been selected, realtime autotuning will not operate normally. If using the gain switching, set the Realtime Autotuning to "not use" (Pn002 = 0).

Parameters Requiring Settings

Parameter number	Parameter name	Explanation	Reference
Pn114	GAIN SWITCHING ENABLE	Set whether to enable or disable gain switching function. 0: Gain switching disabled. 1: Gain switching is enabled according to the setting of next parameter.	P.8-12
POSITION CONTROL mode			
Pn115	SWITCHING mode in Position Control	Set the condition for switching between gain 1 and gain 2.	P.8-13
Pn116	Gain Switching Delay Time in Position Control	Set the delay time for switching from gain 2 to gain 1. (Unit: 0.1 ms)	P.8-15
Pn117	Gain Switching Level in Position Control	Set the judgment level for switching between the gain 1 and gain 2.	P.8-15
Pn118	Gain Switching Hysteresis in Position Control	Set the hysteresis width to be provided in the judgment level set in Gain Switching Level (Pn117).	P.8-15
Pn119	Position Gain Switching Time	Set the time to change from one position gain to the other one. (Unit: 0.1 ms)	P.8-15
SPEED CONTROL mode			
Pn120	SWITCHING mode in Speed Control	Set the condition for switching between gain 1 and gain 2.	P.8-17
Pn121	Gain Switching Delay Time in Speed Control	Set the delay to return from the gain 2 to gain 1. (Unit: 0.1 ms)	P.8-17
Pn122	Gain Switching Level in Speed Control	Set the judgment level for switching between the gain 1 and gain 2.	P.8-17
Pn123	Gain Switching Hysteresis in Speed Control	Set the hysteresis width to be provided in the judgment level set in Gain Switching Level (Pn122).	P.8-17
FORCE CONTROL mode			
Pn124	SWITCHING mode in Force Control	Set the condition for switching between gain 1 and gain 2.	P.8-18
Pn125	Gain Switching Delay Time in Force Control	Set the time to return from the gain 2 to gain 1. (Unit: 0.1 ms)	P.8-19
Pn126	Gain Switching Level in Force Control	Set the judgment level for switching between the gain 1 and gain 2.	P.8-19
Pn127	Gain Switching Hysteresis in Force Control	Set the hysteresis width to be provided in the judgment level set in Gain Switching Level (Pn126).	P.8-19

Diagrams of Gain Switching Setting

Switching between Gain 1 (Pn100 to Pn104) and Gain 2 (Pn105 to Pn109) occurs at the following timings. Take note that, in the case of position loop gains, switching occurs based on the setting of Pn119.

For the details of each gain, refer to "Chapter 8, Parameters Details".

The details of gain switching setting vary depending on the CONTROL mode used.

GAIN SWITCHING mode = 2: Gain Switching (GSEL)

Valid for Position, Speed and Force control.

Instant switching occurs when a gain switching command is issued from the network.

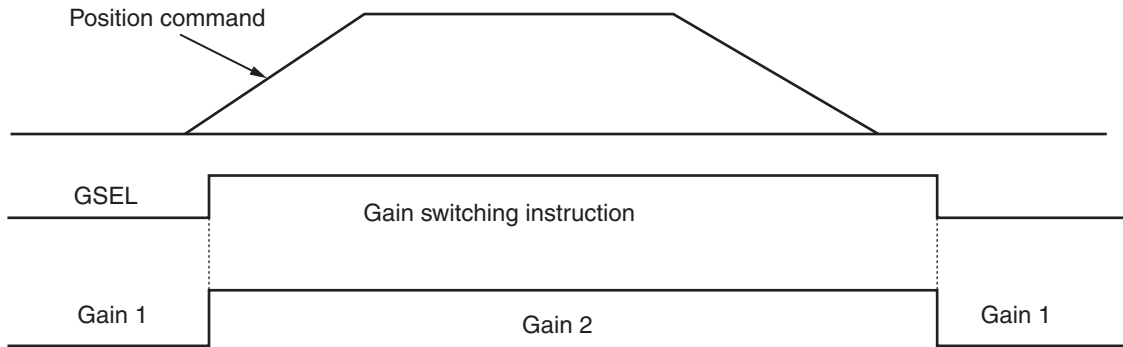

GAIN SWITCHING mode = 3: Switching by Force Command Amount

Valid for:
 Position control (Pn116, Pn117, Pn118).
 Speed control (Pn119, Pn120, Pn121).
 Force control (Pn125, Pn126, Pn127).

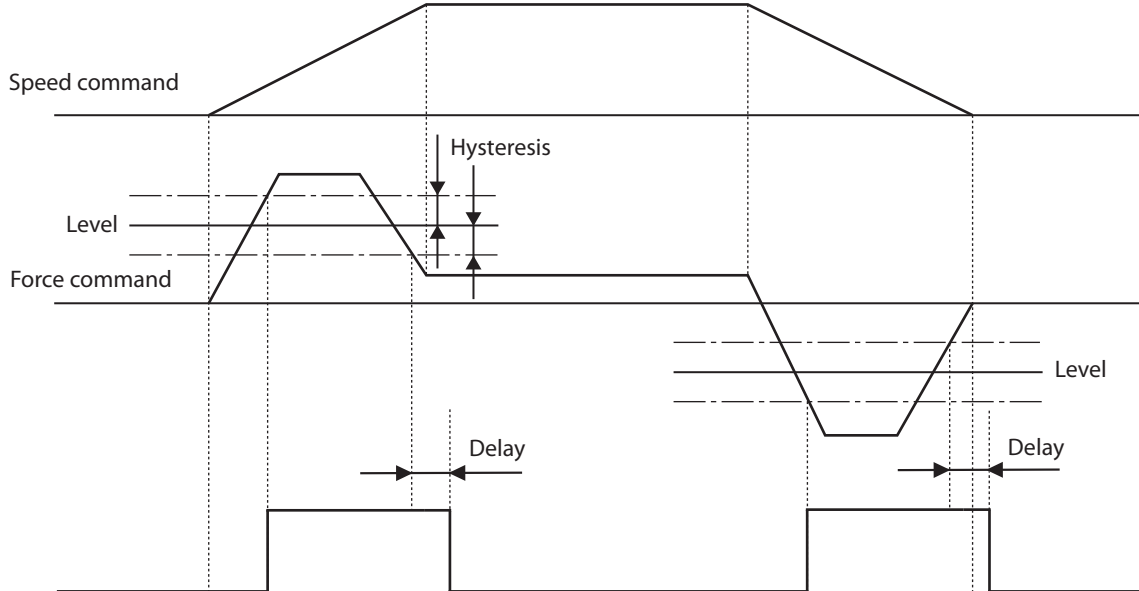

***Note:**
 Delay: Pn116 (Position control)
 Pn121 (Speed control)
 Pn125 (Force control)
 Level: Pn117 (Position control)
 Pn122 (Speed control)
 Pn126 (Force control)
 Hysteresis: Pn118 (Position control)
 Pn123 (Speed control)
 Pn127 (Force control)

GAIN SWITCHING mode = 5, 9: Switching by Speed Command or Actual Motor Speed

Mode=5 valid for position and speed mode and Mode=9 valid for position mode.

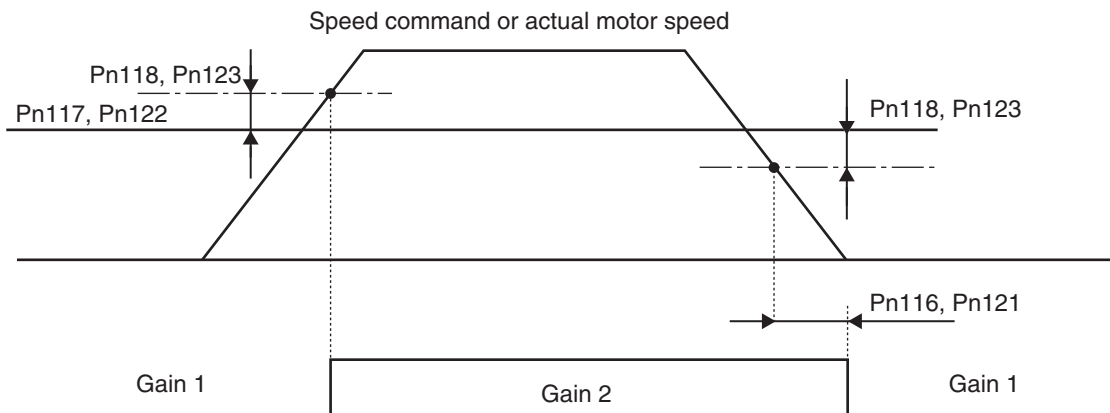

GAIN SWITCHING mode (Pn031) = 6: Switching by Amount of Position Error

Valid for position mode.

Gain switching occurs based on the accumulated count in the error counter.

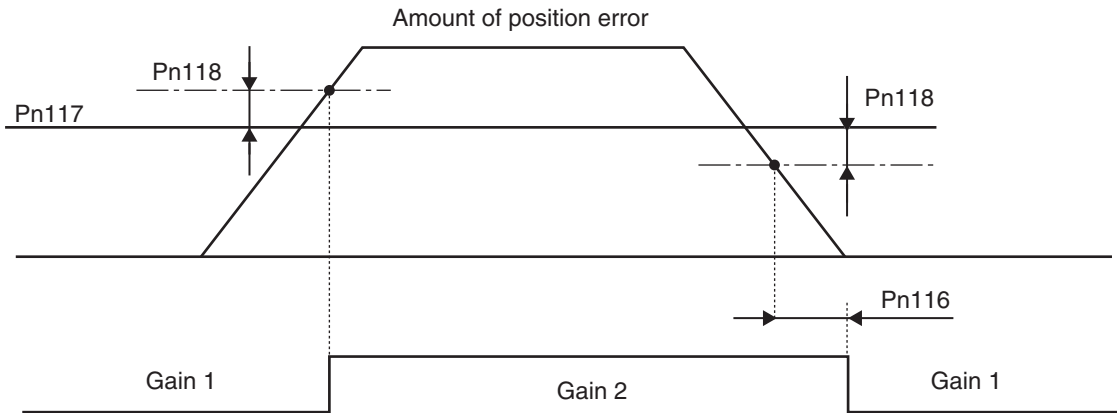

GAIN SWITCHING mode = 7: Switching by Position Command Received

Valid for position mode.

Gain switching occurs when a position command corresponding to 1 command unit or more is received.



GAIN SWITCHING mode = 8: Switching by Positioning Completion Signal OFF

Valid for position mode.

Switching to the gain 2 occurs when the error counter accumulated pulse exceeds the Positioning Completion Range 1 (Pn431).

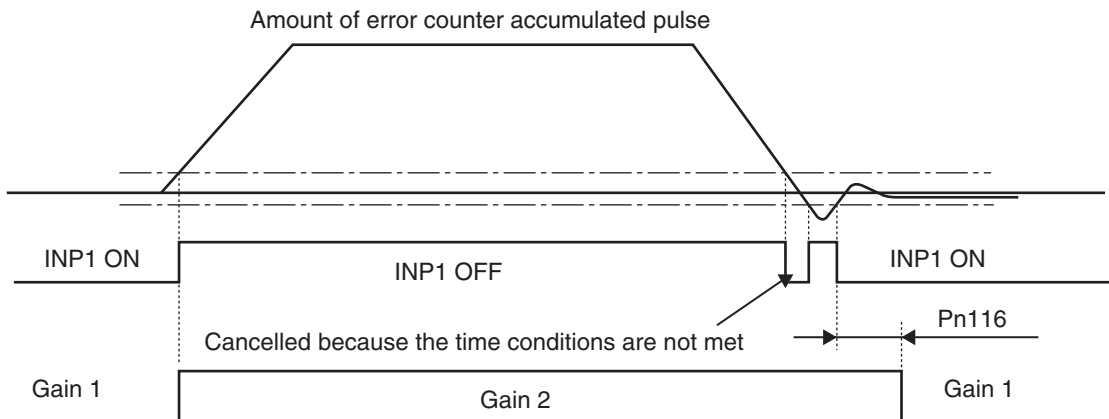

GAIN SWITCHING mode = 10: Switching by Combination of Position Command Received and Speed

Valid for position mode.

Switching to the gain 2 occurs when a position command is received.

If no position command is issued for the period of Gain Switching Delay Time in Speed Control (Pn116) and the speed also becomes the same as or less than the result of Gain Switching Level (Pn117) - Gain Switching Hysteresis (Pn118) [mm/s], switching to the gain 1 will occur.

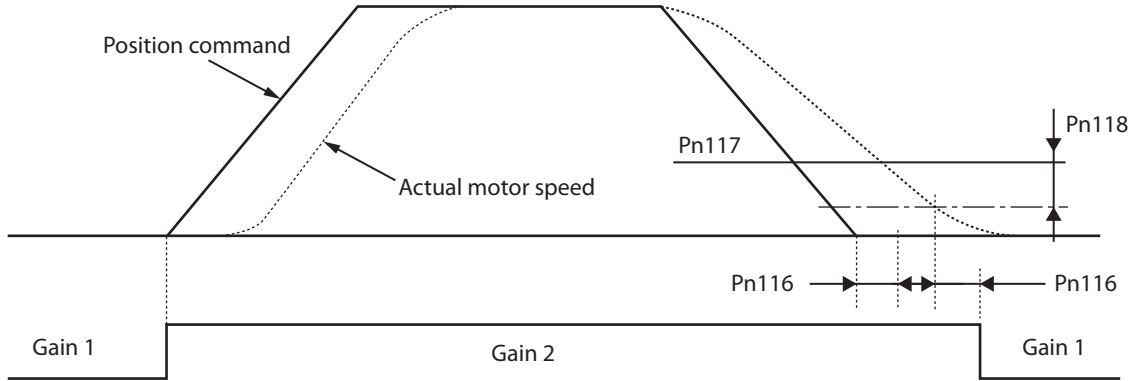

Timings by Position Gain Switching Time (Pn119)

At the time of gain switching, the speed loop gain, speed loop integral time constant, force command filter time constant and speed detection filter switch simultaneously as the switching command. Under this function, however, switching occurs at the set timings so as to reduce mechanical vibration and resonance resulting from switching from low to high gain.

The switching time is set in units of 166 μ s according to the internal cycle. Set 20 in Pn119. If the position loop gain is to be raised from 30 to 50 [1/s], increment the gain by 166 μ s at a time. (3.32 ms) If the position loop gain is to be lowered from 50 to 30 [1/s], lower the gain instantly.

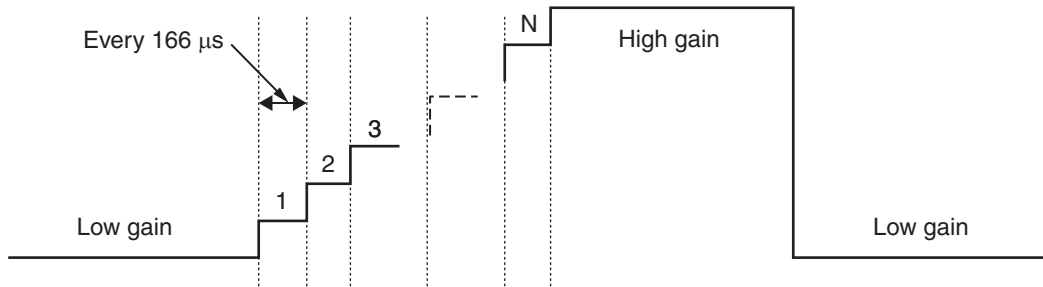

Gain Switching Setting for Each CONTROL mode

The settable switching conditions vary depending on the CONTROL mode used. Set the parameters for each CONTROL mode.

POSITION CONTROL mode

In the POSITION CONTROL mode, it varies as follows according to GAIN SWITCHING mode in Position Control (Pn115).

(√: Enabled, – : Disabled)

Pn115 set value	Switching conditions	Gain Switching Delay Time (Pn116)	Gain Switching Level (Pn117)	Gain Switching Hysteresis (Pn118)	Position Gain Switching Time (Pn119)
0	Always gain 1	–	–	–	–
1	Always gain 2	–	–	–	–
2	Switching from gain switching (GSEL)	–	–	–	√
3	Force command amount	√	√ [%]	√ [%]	√
4	Always gain 1	–	–	–	–
5	Command speed	√	√ [mm/s]	√ [mm/s]	√
6	Amount of position error	√	√ [pulse]	√ [pulse]	√
7	Position command received	√	–	–	√
8	Positioning completion signal (INP1) OFF	√	–	–	√
9	Actual motor speed	√	√ [mm/s]	√ [mm/s]	√
10	Combination of position command received and speed	√	√	√	√

SPEED CONTROL mode

In the SPEED CONTROL mode, it varies as follows according to GAIN SWITCHING mode in Speed Control (Pn120).

(√: Enabled, – : Disabled)

Pn120 set value	Switching conditions	Gain Switching Delay Time (Pn121)	Gain Switching Level (Pn122)	Gain Switching Hysteresis (Pn123)
0	Always gain 1	–	–	–
1	Always gain 2	–	–	–
2	Switching from gain switching (GSEL)	–	–	–
3	Force command amount	√	√ [%]	√ [%]
4	Amount of change in speed command	–	–	–
5	Speed command	√	√ [mm/s]	√ [mm/s]

6-7 Gain Switching Function

FORCE CONTROL mode

In the FORCE CONTROL mode, it varies as follows according to GAIN SWITCHING mode in Force Control (Pn124).

(√: Enabled, – : Disabled)

Pn124 set value	Switching conditions	Gain Switching Delay Time (Pn125)	Gain Switching Level (Pn126)	Gain Switching Hysteresis (Pn127)
0	Always gain 1	–	–	–
1	Always gain 2	–	–	–
2	Switching from gain switching (GSEL)	–	–	–
3	Force command amount	√	√ [%]	√ [%]

6-8 Gain Switching 3 Function

Outline of Operation

You can newly set gain 3 right before stopping to the gain switching function of GAIN SWITCHING INPUT OPERATING mode Selection (Pn114).

You can use the gain 3 switching function in the following situations for position control.

- When servo is ON
- When there is no trouble with the motor's normal movement

Parameters Requiring Settings

Parameter number	Parameter name	Explanation	Reference
Pn605	Gain 3 Effective Time	Set effective time of gain 3.	P.8-57
Pn606	Gain 3 Ratio Setting	Set gain 3 as a multiple of gain 1.	P.8-57

Operation

Gains 1, 2 and 3 Operation Timings

Example: When the SWITCHING mode in position control = 7 and the switching condition is set to position command received

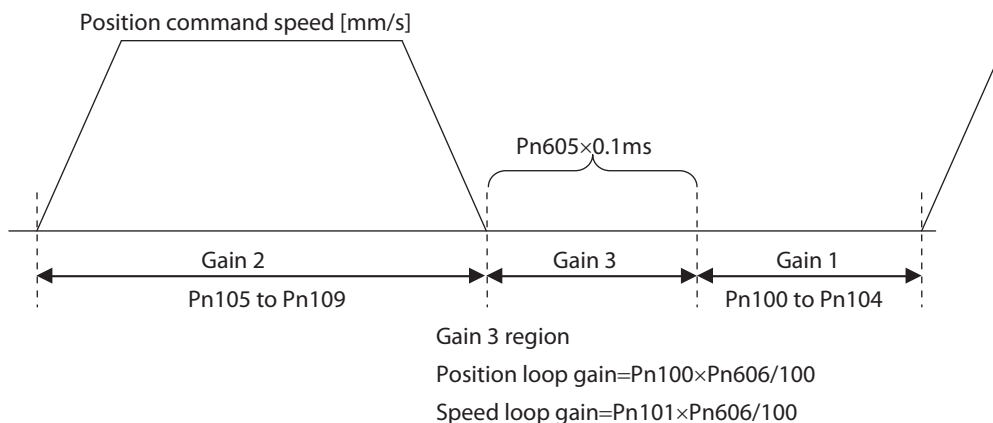

Continue to use gain 1 value for the speed loop integral time constant, speed feedback filter time constant, and torque command filter time constant.



Precautions for Correct Use

- If gain 3 is not used, set the Gain 3 Effective Time (Pn605) to 0 and Gain 3 Ratio Setting (Pn606) to 0.
- Only the position loop gain and the speed loop gain are treated as gain 3 in the gain 3 region, and the gain 1 setting is applied to all other gains.
- If the gain 2 switching condition is established in the gain 3 region, this switches to gain 2.
- If gain 2 is switching to gain 3, Position Gain Switching Time (Pn119) is enabled.
- Take note that there will be a gain 3 region even when gain 2 is switched to gain 1 due to a parameter change and so forth.

6-9 Force Limit

Outline of Operation

- ♦ The output force by the Linear Servomotor can be limited.
- ♦ This function is used in the following conditions.
 - When push-motion operation, such as pressing, is performed.
 - When the force at startup and during deceleration should be suppressed to protect the mechanical system, etc.
- ♦ Various methods are available according to Force Control Selection (Pn521).

Parameters Requiring Settings

Parameter number	Parameter name	Explanation	Reference
Pn521	Force Limit Selection	Select the force limit based on the various parameters and input signals.	P.8-53
Pn013	No. 1 Force Limit	Set the No. 1 motor output force limit value.	P.8-7
Pn522	No. 2 Force Limit	Set the No. 2 motor output force limit value.	P.8-53
Pn523	Force Limit Switching Rate 1	Set the rate of change (fluctuate) when switching from the No. 1 force limit to No. 2 force limit.	P.8-54
Pn524	Force Limit Switching Rate 2	Set the rate of change (fluctuate) when switching from the No. 2 force limit to No. 1 force limit.	P.8-54
Pn525	Forward External Force Limit	Set the forward force limit using a digital signal.	P.8-54
Pn526	Reverse External Force Limit	Set the reverse force limit using a digital signal.	P.8-54
Pn527	Analog Force Limit Scale	Gain for the analogue force input.	P.8-54
Pn425	Analog Input 2 Offset	Set the offset adjustment value for the voltage applied to analog input 2.	P.8-39
Pn426	Analog Input 2 Filter Time Constant	Set the time constant of the first-order lag filter for the voltage applied to analog input 2.	P.8-39
Pn428	Analog Input 3 Offset	Set the offset adjustment value for the voltage applied to analog input 3.	P.8-40
Pn429	Analog Input 3 Filter Time Constant	Set the time constant of the first-order lag filter for the voltage applied to analog input 3.	P.8-40

Force Limit in Position and Speed Control Mode

Pn521 set value	Explanation
0	Forward operation: Set by PCL (0 to 10 V) Reverse operation: Set by NCL (-10 to 0 V)
1	Limit in both forward and reverse operation: Set by Pn013
2	Forward operation: Set by Pn013 Reverse operation: Set by Pn522
3	Switch the limit value using force limit switching (FLSEL). When FLSEL is OFF Limit in both forward and reverse operation: Pn013 When FLSEL is ON Limit in both forward and reverse operation: Pn522
4	Forward operation: Set by PCL (0 to 10 V) Reverse operation: Set by NCL (0 to 10 V)
5	Limit in both forward and reverse operation: Set by PCL (0 to 10 V)
6	Switch the limit value using force limit switching (FLSEL). When FLSEL is OFF Forward operation: Pn013 Reverse operation: Pn522 When FLSEL is ON Forward operation: Pn525 Reverse operation: Pn526

- For the force limit in force control, always select No. 1 Force Limit (Pn013).
- The force limit under force feed-forward selection is enable only during speed control when the set value is 1 to 3.
- PCL signal is assigned to the terminal 16 in CN1. See chapter 3 for details about the connection.
- NCL signal is assigned to the terminal 18 in CN1. See chapter 3 for details about the connection.

Rate of Change Setting at Switching (Pn521 = 3)

If 3 is set in Force Limit Selection (Pn521), you can add fluctuate the change at the time of switching. This function is disabled in any other setting.

How to Set Rate of Change (Fluctuate)

Set the parameter according to the switching type.

- ♦ From No. 1 force limit to No. 2 force limit: Pn523
- ♦ From No. 2 force limit to No. 1 force limit: Pn524

The sign of the rate of change switches automatically inside the drive based on the magnitude correlation of the No. 1 force limit and No. 2 force limit.

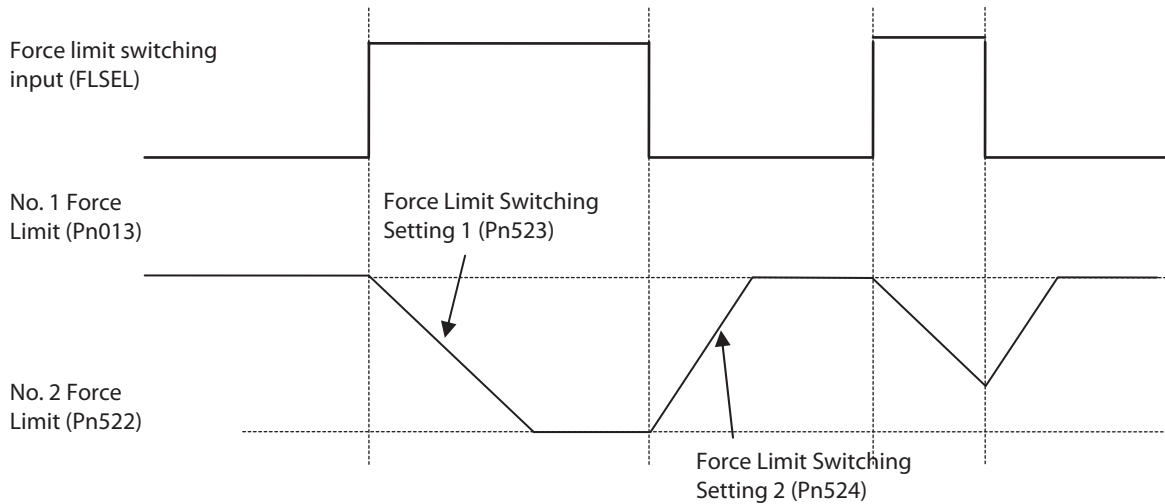

If the setting of No. 1 Force Limit (Pn013) or No. 2 Force Limit (Pn522) is changed from the front panel or CX-Drive, the rate of change setting will be ignored and the new force limit value will be applied immediately.

Force Limit Set Value for Linear Servomotors

- ♦ The setting range for the force limit selection is 0% to 500% and the standard default setting is 500%.
- ♦ In Linear Motors the peak force (specially in Ironless type) is very high compared to nominal, the force may be limited by the drive peak current regardless of the setting of the force limit parameter.

6-10 Sequence I/O Signal

Outline of Operation

- You can set a sequence in various operating conditions.
- For the connection of I/O signals and processing of external signals, refer to P.3-13.

Input Signals

You can allocate any function of input signals to the input pins for the control I/O connector (CN1).

Input Signal Default Setting

The allocation of the default input signals is as follows. Refer to "Input Signal Allocation Method" when you change the allocation to use.

Applicable parameters	Input signals	Default set value	Default setting state					
			Position control		Speed control		Force control	
			Signal name	Logic	Signal name	Logic	Signal name	Logic
Pn400	SI1 input	00828282h (8553090)	NOT	NC	NOT	NC	NOT	NC
Pn401	SI2 input	00818181h (8487297)	POT	NC	POT	NC	POT	NC
Pn402	SI3 input	0091910Ah (9539850)	DFSEL1	NO	VZERO	NC	VZERO	NC
Pn403	SI4 input	00060606h (394758)	GSEL	NO	GSEL	NO	GSEL	NO
Pn404	SI5 input	0000100Ch (4108)	GESEL1	NO	VSEL3	NO	–	–
Pn405	SI6 input	00030303h (1979379)	RUN	NO	RUN	NO	RUN	NO
Pn406	SI7 input	00000f07h (3847)	ECRST	NO	VSEL2	NO	–	–
Pn407	SI8 input	00040404h (263172)	RESET	NO	RESET	NO	RESET	NO
Pn408	SI9 input	00050505h (328965)	TVSEL	NO	TVSEL	NO	TVSEL	NO
Pn409	SI10 input	00000E88h (3720)	IPG	NC	VSEL1	NO	–	–

Contacts NO and NC in the logic fields indicate the following statuses.

Contact NO: Disabled (OFF) when signal input is open with COM–
Enabled (ON) when signal input is shorted with COM–

Contact NC: Disabled (OFF) when signal input is shorted with COM–
Enabled (ON) when signal input is open with COM–

"–" indicates the status where no function is allocated.

Parameters that Can Be Allocated

Use the following parameters when changing the input signal allocation to use. For the setting method, refer to "Input Signal Allocation Method".

Parameter number	Parameter name	Explanation	Reference
Pn400	Input Signal Selection 1	Set the SI1 input function allocation. This parameter is based on the hex display standard.(Take note that the display on the front panel is based on the decimal display.)	P.8-35
Pn401	Input Signal Selection 2	Set the SI2 input function allocation.	P.8-35
Pn402	Input Signal Selection 3	Set the SI3 input function allocation.	P.8-35
Pn403	Input Signal Selection 4	Set the SI4 input function allocation.	P.8-35
Pn404	Input Signal Selection 5	Set the SI5 input function allocation.	P.8-35
Pn405	Input Signal Selection 6	Set the SI6 input function allocation.	P.8-35
Pn406	Input Signal Selection 7	Set the SI7 input function allocation.	P.8-35
Pn407	Input Signal Selection 8	Set the SI8 input function allocation.	P.8-35
Pn408	Input Signal Selection 9	Set the SI9 input function allocation.	P.8-35
Pn409	Input Signal Selection 10	Set the SI10 input function allocation.	P.8-35

Input Signal Allocation Method

Input the setting for each CONTROL mode in any of the parameters of Pn400 to Pn409 to allocate signals.

Set the parameters based on the hex display standard.
 Set the set value of the function for each CONTROL mode in ""*"" below.
 Refer to the function number table provided below for the set value of each function. Logic setting is included in the function numbers.

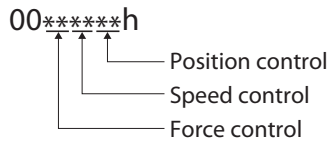

Example:
 Position control: Electronic gear switching input 1 for contact NO (0Ch)
 Speed control: Internally set speed selection 1 for contact NC (8Eh)
 Force control: Disabled (00h)

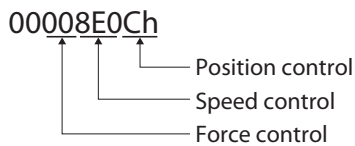

This will be 36364 since the front panel display is in decimal numbers.

Function Number Table

The set values to be used for allocations are as follows.

Signal name	Symbol	Set value	
		Contact NO	Contact NC
Disabled	–	00h	Setting not available
Forward drive prohibition input	POT	01h	81h
Reverse drive prohibition input	NOT	02h	82h
Operation command *1	RUN	03h	83h
Alarm reset input	RESET	04h	Setting not available
CONTROL mode switching input	TVSEL	05h	85h
Gain switching	GSEL	06h	86h
Error counter reset input *2	ECRST	07h	Setting not available
Pulse prohibition input *3	IPG	08h	88h
Force limit switching	FLSEL	09h	89h
Vibration filter switching 1	DFSEL1	0Ah	8Ah
Vibration filter switching 2	DFSEL2	0Bh	8Bh
Electronic gear switching input 1	DIV1	0Ch	8Ch
Electronic gear switching input 2	DIV2	0Dh	8Dh
Internally set speed selection 1	VSEL1	0Eh	8Eh
Internally set speed selection 2	VSEL2	0Fh	8Fh
Internally set speed selection 3	VSEL3	10h	90h
Zero speed designation input	VZERO	11h	91h
Speed command sign input	VSIGN	12h	92h
Force command sign input	FSIGN	13h	93h
Forced alarm input	E-STOP	14h	94h
Mass ratio switching input	M-SEL	15h	95h

*1 The operation command (RUN) always needs to be allocated. Servo cannot be turned ON if it is not allocated.

*2 Allocate this to Input Signal Selection 7 (Pn406). An error will occur if it is allocated to anything other than that.

*3 Allocate this to Input Signal Selection 10 (Pn409). An error will occur if it is allocated to anything other than that.



Precautions for Correct Use

- Do not use any values other than the settings listed.
- If you allocate the same function to multiple input signals, interface input duplicate allocation error 1 (Err33.0) or interface input duplicate allocation error 2 (Err33.1) will occur.
- You can allocate error counter reset input (ECRST) to Input Signal Selection 7 (Pn406) only. If you allocate it to anything other than that, a counter reset allocation error (Err33.6) will occur.
- You can allocate pulse prohibition input (IPG) to Input Signal Selection 10 (Pn409) only. If you allocate it to anything other than that, a command pulse prohibition input allocation error (Err33.7) will occur.
- If you are using the CONTROL mode switching input (TVSEL), you must set it for all CONTROL modes. If you do not set it for all CONTROL modes, interface input function number error 1 (Err33.2) or interface input function number error 2 (Err33.3) will occur.
- If you set Zero Speed Designation Selection (Pn315) to 2 or 3, you must always allocate zero speed designation input (VZERO) in speed control for the same pin where zero speed designation input (VZERO) is allocated for speed control. In addition, specify the same settings for the logic.

- ♦ Be sure to allocate the functions that are used by multiple CONTROL modes (such as operation command and alarm reset input) to the same pin, and do the same for the logic. If this is not set correctly, interface input duplicate allocation error 1 (Err33.0) or interface input duplicate allocation error 2 (Err33.1) will occur.
- ♦ You must always allocate the operation command (RUN). Servo cannot be turned ON if it is not allocated.

Output Signals

You can allocate any function of output signals to the output pins for the control I/O connector (CN1).

Output Signal Default Setting

The allocation of the default input signals is as follows. Refer to "Output Signal Allocation Method" when you change the allocation to use.

Applicable parameters	Output Signals	Default set value	Default setting state		
			Position control	Speed control	Force control
			Signal name	Signal name	Signal name
Pn410	SO1 output	00030303h (197379)	BKIR	BKIR	BKIR
Pn411	SO2 output	00020202h (131586)	READY	READY	READY
Pn412	SO3 output	*1	ALM	ALM	ALM
Pn413	SO4 output	00050504h (328964)	INP	TGON	TGON
Pn414	SO5 output	00070707h (460551)	ZSP	ZSP	ZSP
Pn415	SO6 output	00060606h (394758)	FLC	FLC	FLC

*1 Alarm output signal allocations cannot be changed.

Parameters that Can Be Allocated

Use the following parameters when changing the output signal allocation to use. For the setting method, refer to "Output Signal Allocation Method".

Parameter number	Parameter name	Explanation	Reference
Pn410	Output Signal Selection 1	Set the SO1 input function allocation. This parameter is based on the hex display standard. Refer to the output signal function number table for details.	P.8-35
Pn411	Output Signal Selection 2	Set the SO2 input function allocation.	P.8-35
Pn412	Output Signal Selection 3	Set the SO3 input function allocation. This parameter is always fixed to the alarm output signals.	P.8-35
Pn413	Output Signal Selection 4	Set the SO4 input function allocation.	P.8-35
Pn414	Output Signal Selection 5	Set the SO5 input function allocation.	P.8-36
Pn415	Output Signal Selection 6	Set the SO6 input function allocation.	P.8-36

Output Signal Allocation Method

Input the setting for each CONTROL mode in any of the parameters of Pn410 to Pn415 to allocate signals.

Set up the parameters based on the hex display standard in the same manner as the input signal allocation method.

Set the set value of the function for each CONTROL mode in "*" below.

Refer to the function number table provided below for the set value of each function. Logic setting is included in the function numbers.

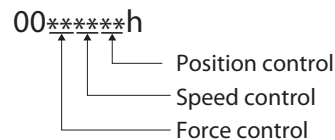

Example:

Position control: Speed conformity output (08h)

Speed control: Motor speed detection output (05h)

Force control: Zero speed detection signal (07h)

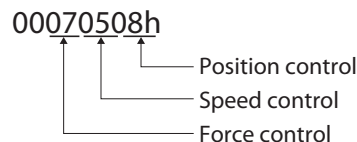

This will be 460040 since the front panel display is in decimal numbers.

Function Number Table

The set values to be used for allocations are as follows.

Signal name	Symbol	Set value
Disabled	–	00h
Servo ready completed output	READY	02h
Brake interlock output	BKIR	03h
Positioning completion output	INP	04h
Motor speed detection output	TGON	05h
Force limiting signal	FLC	06h
Zero speed detection signal	ZSP	07h
Speed conformity output	TGON	08h
Warning output 1	WARN1	09h
Warning output 2	WARN2	0Ah
Position command status output	P-CMD	0Bh
Positioning completion 2	INP2	0Ch
Output during speed limit	V-LIMIT	0Dh
Alarm attribute output	ALM-ATB	0Eh
Speed command status output	V-CMD	0Fh

**Precautions for Correct Use**

- ♦ Do not use any values other than the settings listed.
- ♦ You can allocate the same function to multiple output signals.
- ♦ You cannot change the output signal logic. When the function is disabled (OFF), signal input is open with COM–, and when the function is enabled (ON), signal input is shorted with COM–.

6-11 Forward and Reverse Drive Prohibition Functions

Outline of Operation

- When the forward drive prohibition input (POT) and the reverse drive prohibition input (NOT) are turned OFF, the motor will stop moving.
- You can stop the motor from moving beyond the device's operating range by connecting limit inputs.

Parameters Requiring Settings

Parameter number	Parameter name	Explanation	Reference
Pn400 to Pn409	Input Signal Selection 1 to 10	Set the input signal allocation and logic. In the default setting, the allocations are as follows. Pn400 (CN1 - pin 8): NOT (Logic contact NC) Pn401 (CN1 - pin 9): POT (Logic contact NC)	P.8-35
Pn504	Drive Prohibition Input Selection	Set the operation to be performed upon forward and reverse drive prohibition input.	P.8-45
Pn505	Stop Selection for Drive Prohibition Input	Set the deceleration and stop methods upon forward and reverse drive prohibition input.	P.8-46

Input Signal Selection Function (Default setting: Pn400, Pn401)

In the default setting, the allocations are as follows.

Parameter number	Parameter name	Default setting			
		Set value	Position Control	Speed control	Force control
Pn400	Input Signal Selection 1	00828282	NOT (contact NC)	NOT (contact NC)	NOT (contact NC)
Pn401	Input Signal Selection 2	00818181	POT (contact NC)	POT (contact NC)	POT (contact NC)

- Refer to P.6-35 for details on input signal selections 1 to 10.

Drive Prohibition Input Selection (Pn504)

Install limit switches at both ends of the axis to prohibit the Linear Servomotor from driving in the direction specified by the switch. This can be used to prevent the workpiece from driving too far and thus prevent damage to the machine. Set the operation to be performed upon forward and reverse drive prohibition input.

Drive Prohibition Input Selection (Pn504)	Explanation
0	<p>Forward drive prohibition input and reverse drive prohibition input enabled. The operation when a signal is input will be as follows. Forward drive prohibition input closed: Forward limit switch not operating and status normal. Forward drive prohibition input open: Forward direction prohibited and reverse direction permitted. Reverse drive prohibition input closed: Reverse limit switch not operating and status normal. Reverse drive prohibition input open: Reverse direction prohibited and forward direction permitted. The Linear Servomotor will decelerate and stop according to the sequence set in Stop Selection for Drive Prohibition Input (Pn505). For details, refer to explanation for Stop Selection for Drive Prohibition Input (Pn505). If the forward and the reverse prohibition inputs are both open, an error will be detected in the drive, and a drive prohibition input error (Err380) will occur.</p>
1	<p>Forward and reverse drive prohibition input disabled.</p>
2	<p>Forward and reverse drive prohibition input enabled. If either the forward or the reverse prohibition input is open, a drive prohibition input error (Err380) will occur.</p>

Stop Selection for Drive Prohibition Input (Pn505)

Set the deceleration and stop methods upon a forward or reverse drive prohibition is input.

Stop Selection for Drive Prohibition Input (Pn505)	Deceleration method	After stopping	Error counter
0	Dynamic brake	Force command = 0 for drive prohibition direction	Held
1	Free-run (Force command = 0 for drive prohibition direction)	Force command = 0 for drive prohibition direction	Held
2	Immediate stop	Servo lock	Clear before and after deceleration.

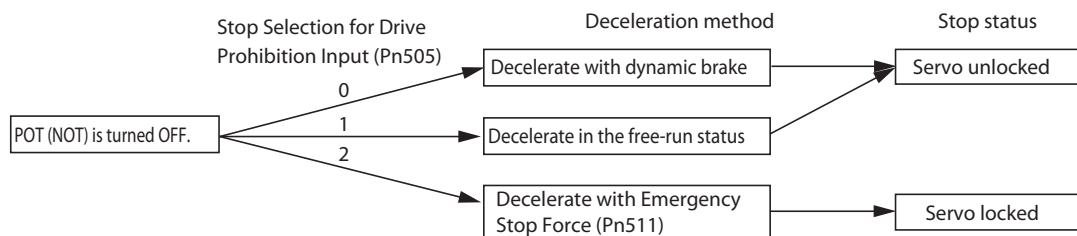

While the Forward Drive Prohibition Input (POT) is OFF, the Linear Servomotor cannot be driven in the forward direction, but it can be driven in the reverse direction. Conversely, while the reverse drive prohibition input (NOT) is OFF, the Linear Servomotor cannot be driven in the reverse direction, but it can be driven in the forward direction.

If immediate stop force is set for deceleration and servo lock is set for stop (set value: 2), force limit during deceleration will be limited with the set value of the Immediate Stop Force (Pn511).



Precautions for Correct Use

- ♦ A load on the vertical axis and so forth may fall due to its own weight in the drive prohibition input state. To prevent the load from falling, set immediate stop force for deceleration and servo lock for stop (set value: 2) in Stop Selection for Drive Prohibition Input (Pn505), or limit the operation using the Host Controller rather than using this function.
 - ♦ Because an immediate stop will force the motor to decelerate quickly, the position error will momentarily be a large value during position control, and Err24.0 "error counter overflow" or Err34.0 "overrun limit error" may occur. In such a case, set the Position Counter Overflow Level (Pn014) and the Overrun Limit Setting (Pn514) to appropriate values.
-

6-12 Disturbance Observer Function

Outline of Operation

You can lower the effect of the disturbance force and reduce the vibration using the estimated disturbance force value.

You can use the disturbance observer in the following situations for position control or speed control.

- ◆ When servo is ON
- ◆ When there is no trouble with the motor's normal movement
- ◆ When realtime autotuning function is disabled
- ◆ When instantaneous speed observer function is disabled

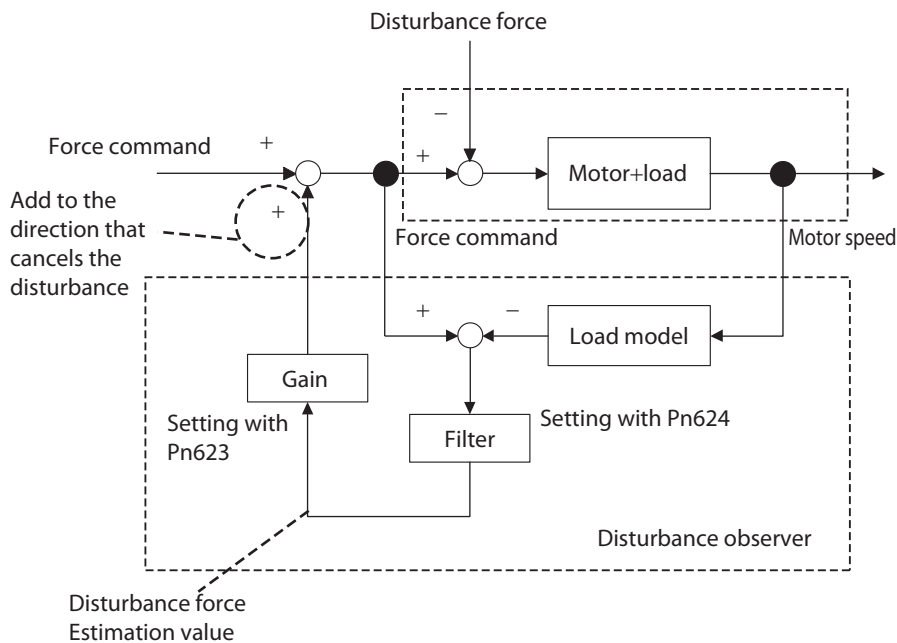

Precautions for Correct Use

- ◆ If there is a resonance point below the cut-off frequency estimated by the disturbance observer, or if a large amount of high-frequency elements are found in the disturbance force, the disturbance observer may not be enabled.

Parameters Requiring Settings

Parameter number	Parameter name	Explanation	Reference
Pn610	Enable of several function	Set the bits related to the disturbance observer.	P.8-57
Pn623	Disturbance Force Compensation Gain	Set the compensation gain for disturbance force.	P.8-60
Pn624	Disturbance Observer Filter Setting	Set the filter time constant for disturbance force compensation.	P.8-60

Operating Procedure

1. Set the Setting of Each Function (Pn610).

Set whether to enable or disable the disturbance observer in bit 1.

0: Disabled

1: Enabled

Set the operating conditions to be enabled in bit 2.

0: Enabled at all time

1: Enabled only when gain 1 is selected

2. Set the Disturbance Observer Filter Setting (Pn624).

Set Disturbance Force Compensation Gain (Pn623) to a small value, and then change the value of Disturbance Observer Filter Setting (Pn624) from a large value to a small value. And set to the set value in which the effectiveness of suppressing the impact of disturbance and the operating noise level are balanced.

3. Set the Disturbance Force Compensation Gain (Pn623).

Change the value of Disturbance Force Compensation Gain (Pn623) from a small value to a large value. And set to the set value in which the effectiveness of suppressing the impact of disturbance and the operating noise level are balanced.

6-13 Friction Force Compensation Function

Outline of Operation

As a function to reduce the effect of friction, you can set the unbalanced load compensation that always compensates the constantly working offset force, and the dynamic friction compensation that changes its direction depending on the operating direction.

You can use the force compensation in the following situations for position control or speed control.

- ◆ When servo is ON
- ◆ When there is no trouble with the motor's normal movement

Parameters Requiring Settings

Parameter number	Parameter name	Explanation	Reference
Pn607	Force Command Value Offset	Set the unbalanced load compensation value that is always added to the force command in the CONTROL mode other than force control.	P.8-57
Pn608	Forward Direction Force Offset	Set the dynamic friction compensation value that is added to the force command when a forward direction command input for position control or speed control is issued.	P.8-57
Pn609	Reverse Direction Force Offset	Set the dynamic friction compensation value that is added to the force command when a reverse direction command input for position control or speed control is issued.	P.8-57

Operation Example

Force Command Value Offset (Pn607) reduces the variations of positioning operations due to the movement directions when a certain amount of unbalanced load force is always applied to the motor like the vertical axis and so forth if that force command value is set.

Forward Direction Force Offset (Pn608) and Reverse Direction Force Offset (Pn609) are used with loads that require a large amount of dynamic friction force. By setting the friction force for each direction for all parameters, you can reduce the deterioration and inconsistencies of positioning stabilization time due to dynamic friction.

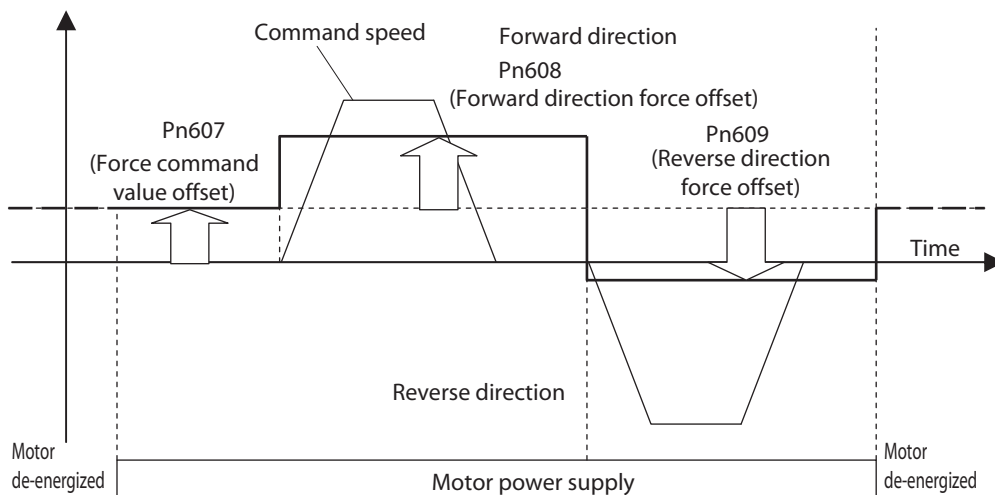

Precautions for Correct Use

You can use the unbalanced load compensation and the dynamic friction compensation together or separately. Take note that the following use limit is applied upon CONTROL mode switching or servo ON.

- ♦ During force control
 - The unbalanced load compensation and the dynamic friction compensation will be 0 regardless of the parameter setting.
- ♦ During speed control
 - The load compensation is enabled based on Pn607 when the servo is turned OFF. The dynamic friction compensation will be 0 regardless of the parameter setting.
- ♦ When the servo is turned ON during position control
 - The unbalanced load compensation and the dynamic friction compensation values will be held until the first position command is input. When the position command is input, the unbalanced load compensation will be updated based on Pn607. Also, based on the command direction, the dynamic friction compensation value will be updated according to parameters Pn608 or Pn609.

6-14 Mass Ratio Switching Function

Outline of Operation

You can switch the mass ratio from 1 or 2 using mass ratio switching input (MSEL). This functions effectively if used when the load mass changes in 2 levels.

You can use mass ratio switching in the following situations.

- ◆ When servo is ON
- ◆ When there is no trouble with the motor's normal movement
- ◆ When realtime autotuning is disabled
- ◆ When adaptive filter function is disabled
- ◆ When instantaneous speed observer function is disabled
- ◆ When disturbance observer function is disabled

Parameters Requiring Settings

Parameter number	Parameter name	Explanation	Reference
Pn610	Enable of several function	Set the bits related to mass ratio switching.	P.8-57
Pn004	Mass Ratio	Set the mass ratio 1.	P.8-3
Pn613	Mass Ratio 2	Set the mass ratio 2.	P.8-58

Operating Procedure

1. **Set the Setting of Each Function (Pn610).**
Set whether to enable or disable mass ratio switching in bit 3.
0: Disabled
1: Enabled
2. **Set the Mass Ratio 1 (Pn004).**
3. **Set the Mass Ratio 2 (Pn613).**
4. **Set the mass ratio switching input (MSEL).**

Setting of Each Function (Pn610)	Mass ratio switching input (MSEL)	Applicable mass ratio
When bit 3 = 0: Mass ratio switching is disabled	OFF	Mass Ratio 1 (Pn004)
	ON	
When bit 3 = 1: Mass ratio switching is enabled	OFF	Mass Ratio 2 (Pn613)
	ON	



Precautions for Correct Use

- ◆ Be sure that the motor is stopped when using the mass ratio switching function.
- ◆ If the difference between mass ratio 1 and mass ratio 2 is large, a vibration may occur even if the motor is stopped. Use it upon confirming that there is no problem with vibration on the actual machine.

6-15 Feed-forward Function

Outline of Operation

The feed-forward function come in 2 types, speed feed forward and force feed forward.

The speed feed forward can minimize the position error and increase the responsiveness by calculating the speed control command that is required for the operation based on the internal positioning command during position control, and adding it to the speed command that is calculated based on the comparison with the position feedback.

The force feed forward can increase the responsiveness during speed control by calculating the force command that is required for the operation based on the speed control command, and adding it to the force command that is calculated based on the comparison with the speed feedback.

Parameters Requiring Settings

Parameter number	Parameter name	Explanation	Reference
Pn110	Speed Feed-forward Amount	Use this parameter to add the speed control command calculated from the internal positioning command that is multiplied by this parameter's ratio to the speed command from the position control process.	P.8-12
Pn111	Speed Feed-forward Command Filter	Set the time constant for the first-order lag filter that is applied to speed feed-forward inputs.	P.8-12
Pn112	Force Feed-forward Amount	Use this parameter to add the force command calculated from the speed control command that is multiplied by this parameter's ratio to the force command from the speed control process.	P.8-12
Pn113	Force Feed-forward Command Filter	Set the time constant for the first-order lag filter that is applied to force feed-forward inputs.	P.8-12
Pn600	Analog Force Feed-forward Gain Setting	Set the input gain for analog force feed forward. 0 to 9 will be disabled.	P.8-57
Pn610	Enable of several function	Bit 5 enables the Analogue Force feed forward.	P.8-57

Operating Procedure

Speed Feed-forward Operating Method

1. Set the Speed Feed-forward Command Filter (Pn111).

Set it to 50 (0.5 ms) or so.

2. Adjust the Speed Feed-forward Amount (Pn110).

Gradually increase the value of Speed Feed-forward Amount (Pn110) and finely adjust it to avoid overshooting during acceleration/deceleration.

If the speed feed-forward amount is set to 100%, the position error will be 0 during constant speed operation. However, a large overshooting will occur during acceleration/deceleration.

The position error during an operation at a certain speed can be smaller based on the following formula according to the speed feed-forward gain value.

$$\text{Position error [command unit]} = \text{command speed [command unit/s]} / \text{position loop gain [1/s]} \times (100 - \text{speed feed-forward amount [\%]}) / 100$$

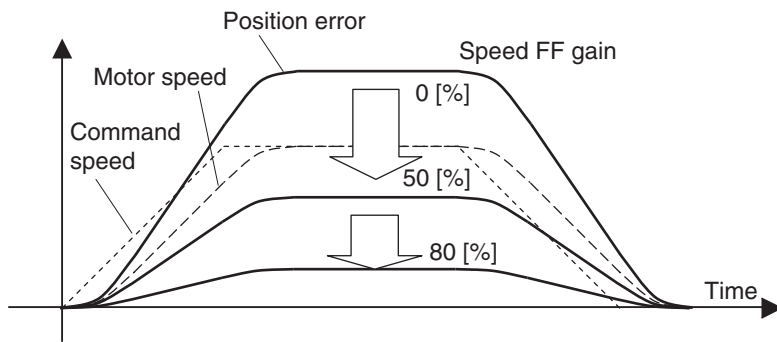

The position error in the range of constant speed becomes smaller as the speed feed-forward gain increases.



Precautions for Correct Use

- ♦ The operating noise may increase when the speed feed forward is enabled if the update cycle of the position command input is longer than the amplifier control cycle, or if the pulse frequency is not uniform. In such cases, apply the position command filter (first-order lag or FIR smoothing) or raise the speed feed-forward filter setting.

Force Feed-forward Operating Method

1. Set the Mass Ratio (Pn004).

Set the mass ratio as correctly as possible.

- If the mass ratio is calculated for the selected motor, input the calculated value.
- If the mass ratio is not known, perform autotuning and set the mass ratio.

2. Set the Force Feed-forward Command Filter (Pn112).

Set it to 50 (0.5 ms) or so.

3. Adjust the Force Feed-forward Amount (Pn113).

Gradually increase the value of Force Feed-forward Amount (Pn113).

Since the position error during acceleration/deceleration at a certain speed can be brought close to 0, it can be brought almost to 0 throughout the entire operation range during a trapezoidal speed pattern drive under ideal conditions where no disturbance force is working. In reality, disturbance force is always present and, therefore, the position error cannot be completely 0.

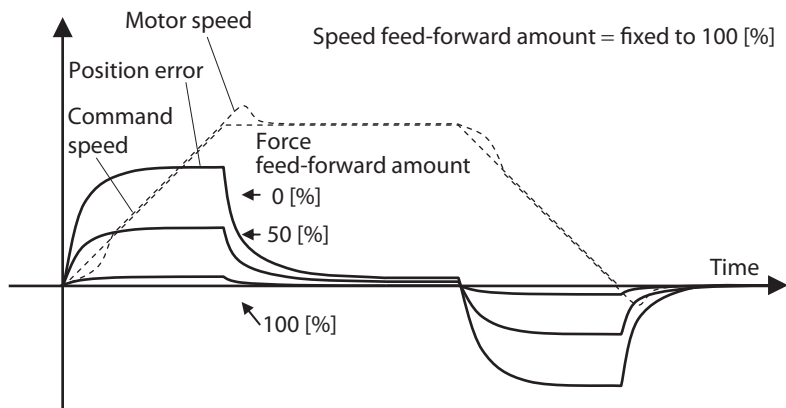

Force feed forward can reduce the position error in movements with constant acceleration and deceleration.

- When operating in position control, this function normally is used together with the velocity feedforward.



Precautions for Correct Use

- If you raise the force feed-forward filter time constant, the operation noise will become smaller. However, the position error at the point of change in acceleration will become larger.

Application Example of Analog Force Feed Forward

The analog force feed forward is enabled when bit 5 of the Setting of Each Function (Pn610) is set to 1. In addition, if analog input 3 is used by another function (for example, analog force limit), this function is disabled.

It is converted to force from the voltage [V] that is applied to analog input 3 based on the Analog Force Feed-forward Gain Setting (Pn600) and is added to the force command [%].

The conversion from the input voltage [V] to analog input 3 to a force command [%] to the motor is performed as illustrated in the graph below. The slope of the graph is when Pn600 = 30. The slope changes based on the Pn600 set value.

$$\text{Force command [\%]} = 100 \times \text{Input voltage [V]} / (\text{Pn600 set value} \times 0.1)$$

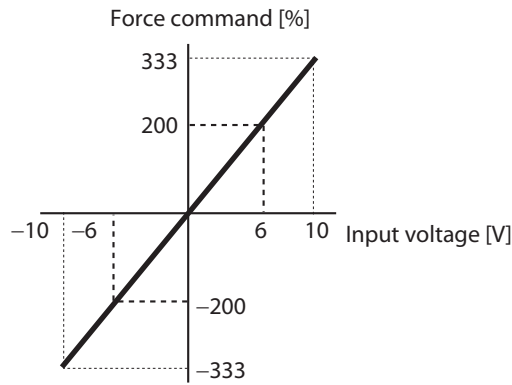

6-16 Instantaneous Speed Observer Function

Outline of Operation

Estimating the motor speed using a load mass increases responsiveness and reduces vibration at stopping and improves the speed detection accuracy. This function can be used for position control.

The instantaneous speed observer function can be used in the following situations.

- ◆ When servo is ON
- ◆ When there is no trouble with the motor's normal movement
- ◆ When realtime autotuning is disabled

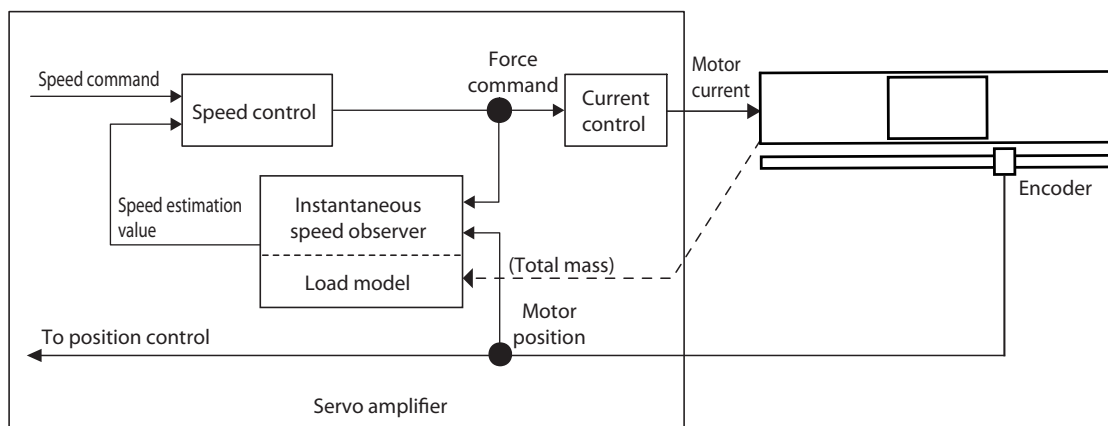

*The use of this function can improve the behaviour when using an encoder with low resolution.

Parameters Requiring Settings

Parameter number	Parameter name	Explanation	Reference
Pn610	Setting of Several Function	Set whether to enable or disable the instantaneous observer function.	P.8-57
Pn004	Mass Ratio	Set the mass ratio 1.	P.8-3
Pn100	Position Loop Gain	Set the position loop gain.	P.8-9
Pn101	Speed Loop Gain	Set the speed loop gain.	P.8-10
Pn103	Velocity detection filter 1	To select the velocity detection filter 1 setting out of 6 preset values.	P.8-11
Pn108	Velocity detection filter 2	To select the velocity detection filter 2 setting out of 6 preset values.	P.8-11

Operating Procedure

1. Set the Mass Ratio (Pn004).

Set the mass ratio as correctly as possible.

- ♦ If the Mass Ratio (Pn004) is requested in a realtime auto gain tuning, use the set value.
- ♦ If the Mass Ratio is calculated for the selected motor, input the calculated value.
- ♦ If the Mass Ratio is not known, perform autotuning and set the mass ratio.

2. Adjust the position loop gain and speed loop gain.

Adjust Position Loop Gain (Pn100), Speed Loop Gain (Pn101), Speed Loop Integral Time Constant (Pn102) and Force Command Filter Time Constant (Pn104).

If no problem occurs in realtime autotuning, you can continue to use the settings.

3. Set the Setting of Each Function (Pn610).

Set whether to enable or disable the instantaneous speed observer function in bit 0.

0: Disabled

1: Enabled

If you set this to 1 (enabled), the speed detection method will switch to instantaneous speed observer.

- ♦ If the machine operation noise or vibration, or a change in the force monitor waveform is significant enough to cause any problem, return the setting to 0 and make sure that the mass ratio or the adjustment parameters are correct.
- ♦ If the machine operation noise or vibration, or a change in the force monitor waveform is small, make small adjustments to the Mass Ratio (Pn004) to find the setting that makes the smallest change while monitoring the position error waveform and the actual speed waveform.
- ♦ If Position Loop Gain (Pn100), Speed Loop Gain (Pn101) or Speed Loop Integral Time Constant (Pn102) is changed, the optimal value for the Mass Ratio (Pn004) may have changed, so make small adjustments on the value for the Mass Ratio (Pn004) again to set a value that makes the smallest change.



Precautions for Correct Use

- ♦ It may not function properly or the effect may not be apparent under the following conditions.
 - If the margin of error with the actual device is large for the mass load
 - If there are multiple resonance points
 - If there is a large resonance point at the frequency of 300 Hz or lower
 - If there is a non-linear element like play
 - If the load mass changes
 - If a large disturbance force with high-frequency elements is applied
 - If the setting range for positioning is small
-

6-17 Motor Setup

Outline of Operation

As the linear motor is not a system by itself but need to be assembled to have a working system, automatic recognition of the linear motor and encoder is not possible.

So, it is necessary to tell the servodrive wich linear motor model is connected and wich encoder type and resolution is used.

The setup is normally done via CX-Drive in a transparent manner so, the user does not need to manually enter the parameter for the motor and the encoder.

Parameters Requiring Settings

You do not normally need to modify those parameter manually, use the CX-Drive for making the setup of the motor and encoder.

Parameter number	Parameter name	Explanation	Reference
Pn900	Reserved	Do not change this setting	P.8-62
Pn902	Pole pitch	Set the magnet pole pitch in 0.01mm. Error 60.0 (abnormal setting) is generated if the set value is 0.	P.8-62
Pn904	Motor mass	Set the mass of the linear motor coil in 0.01Kg. Error 60.0 (abnormal setting) is generated if the set value is 0.	P.8-62
Pn905	Motor nominal force	Set the nominal force of the linear motor in 0.1N. Error 60.0 (abnormal setting) is generated if the set value is 0.	P.8-62
Pn906	Motor nominal rms current	Set the nominal rms current of the linear motor in 0.1 Arms. Error 60.0 (abnormal setting) is generated if the set value is 0. Error 60.1 (motor combination error 1) appear if this value is bigger than the servodrive nominal current.	P.8-62
Pn907	Motor peak absolute current	Set the absolute peak current of the linear motor in 0.1A. Error 60.0 (abnormal setting) is generated if the set value is 0. Error 60.1 (motor combination error 1) appear if this value is bigger than the servodrive peak absolute current.* ¹	P.8-62
Pn908	Motor inductance	Set the per-phase motor inductance in 0.01mH. Error 60.0 (abnormal setting) is generated if the set value is 0.	P.8-62
Pn909	Motor resistance	Set the per-phase motor resistance in 0.01Ω. Error 60.0 (abnormal setting) is generated if the set value is 0.	P.8-63
Pn910	Overvelocity level	Set the level in mm/s to generate Error 26.0 (Overspeed protection). Select a value that is same or lower than the motor maximum speed. Error 60.0 (abnormal setting) is generated if the set value is 0.	P.8-63
Pn911	Switching frequency selection	Select the switching frequency of the servodrive: 0: 6KHz 1: 12KHz Selecting 6KHz the current can give more current to the motors but the frequency generated contains more harmonics.	P.8-63
Pn912	Current loop tuning	Adjust the responsiveness of the current loop by one parameter. Recommended values are: 40 when switching frequency is 12KHz 80 when switching frequency is 6KHz If set to 0, proportional gain and integral gain can be adjusted individually.	P.8-63
Pn913	Current loop proportional gain	Set the proportional gain for the current loop. If Pn912<>0 this value is adjusted automatically * ²	P.8-63
Pn914	Current loop integral gain	Set the integral gain for the current loop. If Pn912<>0 this value is adjusted automatically * ²	P.8-63
Pn929	Motor overload curve selection	Selects between different overload curves. The overload curve protects the motor for overheating due to excessive current in the windings. Selects the curve that better suits the linear motor thermal time constant.	P.8-65

*1: This value is expressed as absolute peak. If the motor peak current is expressed as rms value, you have to multiply by next factor.

$$Pn907 = I_{\text{peak-rms}} \cdot \sqrt{2}$$

*2: Normally use the recommended values for Pn912. This setting is done by CX-Drive automatically. Modifying manually the current loop may handle to motor vibration and mechanical damage.

Operating Procedure

1. Make sure the mechanical and electrical installation is properly done.

2. Make sure the motor phases are connected in the right order (U-V-W).

If the motor phases are connected in that order, the positive direction will be in the direction of the output cables.

3. Configure the linear motor with the CX-Drive.

a. Connect to the servodrive or choose the servodrive if working offline.

b. Select the “motor & encoder setup” wizard.

c. Select the PWM frequency first.

The smaller drives only work at 12KHz switching frequency.

In the rest of the drives you can choose to work at 6KHz or at 12KHz.

The criteria is next:

At 6KHz the drive can drain more current than with 12KHz to the motor so, you select a smaller servodrive for the same motor.

At 6KHz the PWM frequency generated to the motor contains more harmonics than the one generated at 12KHz and this may decrease the linear motor performance. Also the acoustic noise is higher at 6KHz.

So choose 12KHz if:

- The electrical installation is not good (poor ground, no proper shielding...).

- The encoder resolution is not very high.

- To reduce acoustic noise is important.

In other cases you can work with 6KHz switching frequency.

d. Select the motor from the table. The color code will tell you if the motor can run with the drive.

i. **GREY:** That motor is not suitable for that drive because the nominal current of the drive is below the nominal current of the drive or the drive is far too big the motor.

ii. **RED:** The drive can give the motor nominal current but the drive peak current is below the motor peak current so you lose some of the motor performance. Compare the drive and motor currents to understand how much peak force you lose with that combination.

iii. **GREEN:** This is an optimum drive-motor combination (For that PWM frequency). The drive can drain the nominal and peak current of the motor and it is not oversized.

iv. **ORANGE:** You can drive the motor with full nominal and peak force but the drive is oversized. You have smaller drives that can run the motor.

Once you select the motor, the right motor parameter are downloaded to the servodrive and saved if you are online. So, in fact, you do not need to know the OMRON Linear Motor electrical specification.

6-18 Encoder Setup

Outline of Operation

A linear motor system needs a linear encoder. As there are various types of encoders that can be used, the encoder has to be configured.

Next encoder types are supported:

- A/B line drive quadrature pulses
- SinCos line drive (needs the "SerialConverter")
- Serial Incremental Encoder
- Serial Absolute Encoder

Parameters Requiring Settings

Parameter number	Parameter name	Explanation	Reference
Pn901	Encoder resolution	Set here the encoder resolution in 0.01 μ m/count. The value here is after interpolation.	P.8-62
Pn323	Encoder type	Select here the type of encoder used: 0: A/B quadrature 1: Serial Incremental or SinCos + Serial Converter 2: Serial Absolute	P.8-33
Pn326	Encoder count direction	Reverses the count direction of the encoder: 0: Non reversed 1: Reversed	P.8-34

Operating Procedure

1. Make sure the mechanical and electrical installation is properly done.
2. Use the CX-Drive linear motor setup wizard to configure the encoder type.

3. Select the right encoder type (Pn323)

Select the encoder type according to the choosed one:

=0 Line Drive A/B quadrature pulses

This encoder is directly wired to the CN4 connector.

Bandwith is limited to 4MHz after quadrature (1Mpulse/s).

It is recommended to use encoder resolution of 20 μ m/pulse or better. Poor encoder resolutions can deal to low motor performance.

=1 Serial Incremental Encoder

With this setting you can connect next types of encoder:

-SinCos Encoder with Serial Converter

SinCos encoder is connected to the Serial Converter, this device interpolates the SinCos signal by 400 before quadrature and send the position information via serial link. The bandwidth of the Serial Converter is 400KHz (before quadrature). The Serial Converter also allows the connection of a Hall sensor and Temperature sensor whose information is also sent to the drive via the serial link.

-Incremental Encoder with embedded serial interface

Sony manufacturing can provide an encoder with the G5-Linear encoder serial interface embedded in the encoder read-head. This encoder can be directly connected to the CN4 connector. Refer to the manufacturer specification for details.

=2 Serial Absolute Encoder

Sony manufacturing and Titutoyo can provide absolute encoders with embedded G5-Linear encoder serial interface in the encoder read-head. This encoder can be directly connected to the CN4 connector. Refer to the manufacturer specification for details.

4. Adjust the Encoder resolution (Pn901)

If using an A/B pulse, the value is after x4 multiplication.

If using a SinCos Encoder, the value is after interpolation in the Serial Converter (x400 multiplication).

If using an Encoder with embedded serial interface, refer to the maker specification.

5. Confirm the count direction (Pn326)

Due to installation necessities it is possible that the motor direction and the encoder direction do not correspond. So you have to check that the encoder count positive direction is same than the motor positive direction. If you move the motor by hand you can monitor the speed and/or the position and confirm if it counts positive in the direction of the motor cables.

If the motor counts negative in the direction of the motor cables you have to reverse the count direction.

It is possible that, due to the way the motor is installed, you are not sure which is the positive direction of the motor, in this case you have to measure the phase order of the induced voltage in the motor.

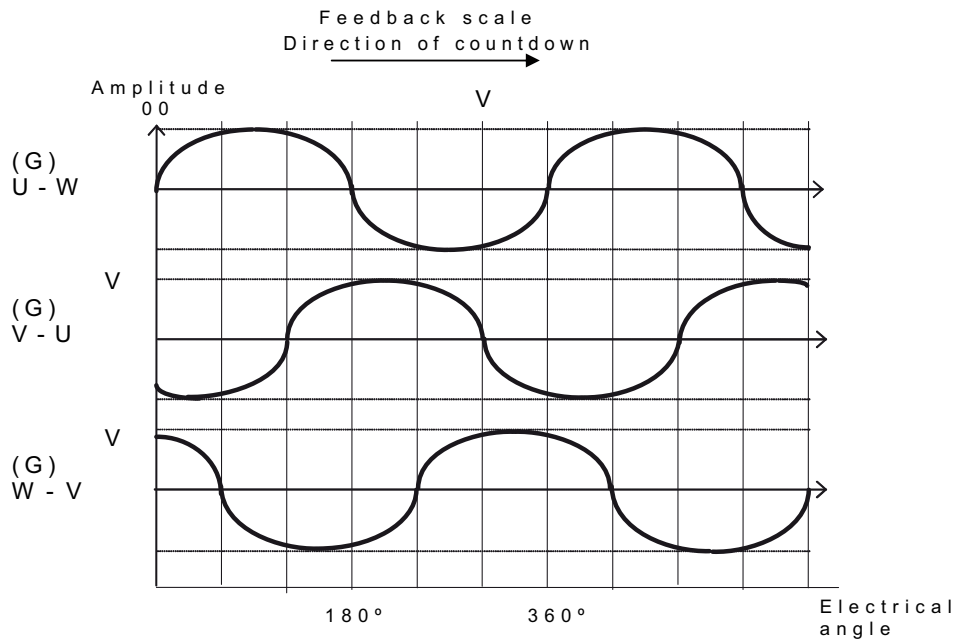

If you are online, the right settings will be downloaded to the drive and saved in the EPROM.

6-19 Magnetic Pole Position

Outline of Operation

For a proper control of a linear motor the drive has to know the magnetic pole position (electrical angle) of the magnets relative to the coil windings.

The drive has three ways to know the magnetic pole position:

By doing a “magnetic pole position estimation sequence“ where the drive measures in an indirect way the electrical angle.

By a direct measurement via hall sensors in the motor that are connected to the Serial Converter. This method is valid only when a SinCos Encoder is used.

Recovering the magnetic pole position measured or estimated previously. This method is valid with Absolute Serial Encoder only.

Parameters Requiring Settings

Parameter number	Parameter name	Explanation	Reference
Pn920	Magnetic pole position measurement method	0: Invalid setting. Error 60.0 (abnormal setting) is generated if the set value is 0. 1: Direct measurement via Hall sensor 2: Magnetic pole position estimation 3: Magnetic pole position restoration	P.8-64
Pn921	Electrical angle phase	Set here the phase between the motor coil winding and the Hall sensor. If using the standard Hall sensors leave this value to 0.	P.8-64
Pn922	Magnetic pole position estimation operation time	In the magnetic pole position estimation method, selects the maximum time to apply the selected force to the motor.	P.8-64
Pn923	Magnetic pole position estimation operation force	In the magnetic pole position estimation method, selects the force to apply to the motor.	P.8-64
Pn924	Magnetic pole position estimation operation movement counts	In the magnetic pole position estimation method, selects the number of pulses that the motor must move to set zero force.	P.8-65
Pn925	Magnetic pole position estimation operation pulses for stop judgement	In the magnetic pole position estimation method, the motor is considered stopped after a movement if it moves less than Pn925 counts in 2 ms and continues stopped for Pn926 ms or more.	P.8-65
Pn926	Magnetic pole position estimation operation time for stop judgement		P.8-65
Pn927	Magnetic pole position estimation operation maximum time	In the magnetic pole position estimation method, determines the maximum time for the motor to stop after a movement before giving error 61.1 (electrical angle estimation error).	P.8-65
Pn928	Magnetic pole position estimation operation force filter time constant	In the magnetic pole position estimation method set the time constant for the Force command. If set to 0 the filter is disabled and a force step is applied.	P.8-65

Operating Procedure

Magnetic pole direct measurement (Pn920=1)

With this method, the magnetic pole position is directly measured via Hall sensors in the linear servomotor.

The Hall sensors are connected to the Serial Converter and the Serial Converter transfer the information to the servodrive via serial link. That means that the Hall sensors have to be used always in combination with a SinCos Encoder.

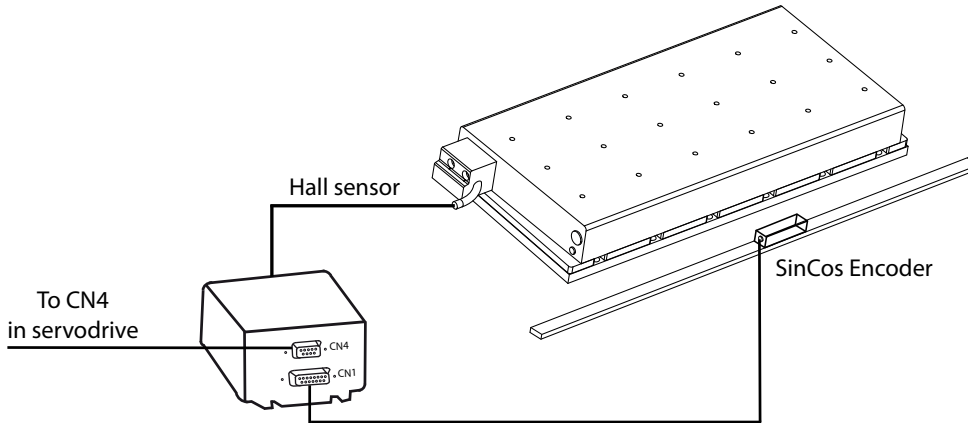

The Hall sensors must be installed in the motor coil and have to be ordered separately. The Hall sensor have been designed so the phase offset between the Hall sensor measurement and the motor windings is zero.

If, for some reason, the Hall sensor must be installed in other place, it is necessary to adjust the phase between the Hall sensors and the motor coils in Pn921 as the next figure shows.

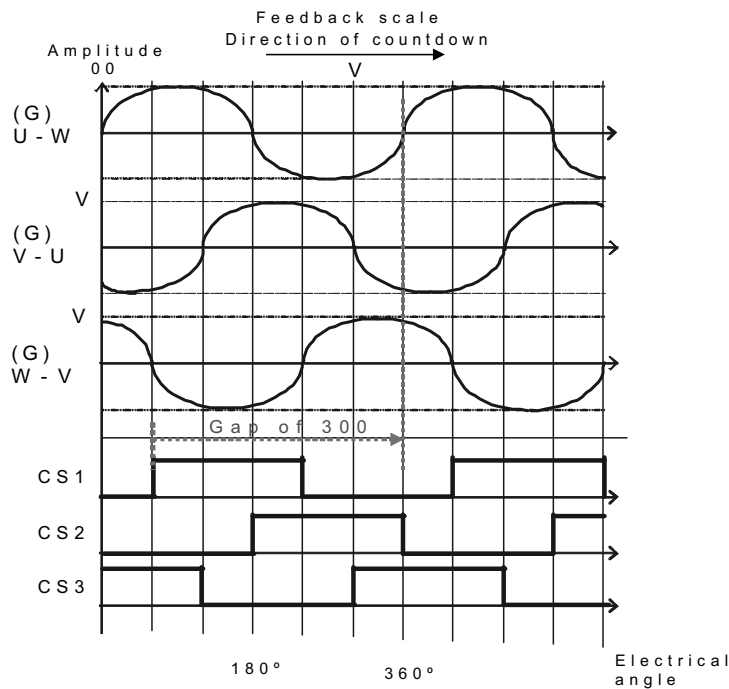

Magnetic pole position estimation (Pn920=2)

On the first RUN command after power on the drive performs a sequence to estimate the magnetic pole position.

The magnetic pole position estimation sequence may not work properly in next cases:

- In vertical axes.
- When the friction is very large.

During the sequence, the servodrive applies a certain force to the motor and measures how much the motor moves.

In order to ensure an accurated estimation, some parameter are provided to adjust the magnetic pole position estimation sequence.

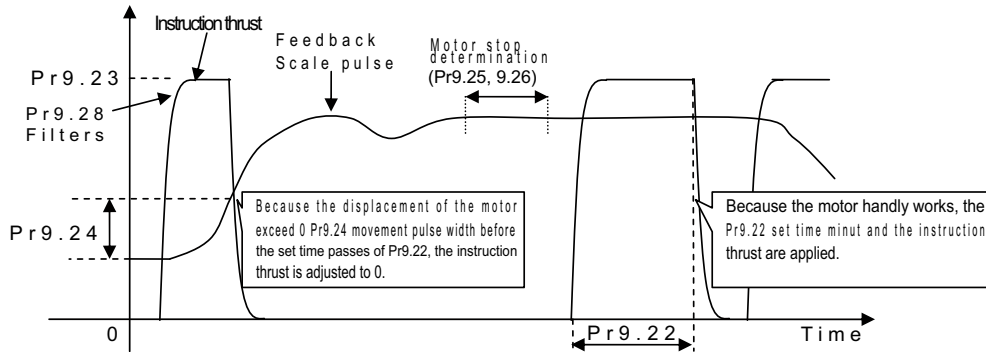

Pn922 defines the maximum time that the force is applied to the linear motor. If this value is too small the motor may not move or the estimation is innacurated.

Pn923 defines the force that is applied to the motor. If this value is too small the motor may not move or the estimation is innacurated.

If the motor moves Pn924 counts the drive considers that the linear motor has moved beacuse of the force and stops applying the force. If this value is very small the estimation can be innacurated. As indication, set at least the value in counts that correspond to one electrical degree.

If the motor moves less than Pn925 counts in 2ms and continues stopped for Pn926 ms after a movement, the motor is considered stopped.

Magnetic pole position restoration (Pn920=3)

This method can only be used in combination with an absolute serial encoder type (Pn323=2). In this case the magnetic pole position estimation sequence is executed only the first RUN command after setting Pn923=3. Once this sequence is finished successfully, the value is stored in EEPROM and recovered after power on.

As the magnetic pole position rely in the absolute encoder position, if there is a mechanical change in the linear motor installation, it is necessary to make a new pole position estimation. You can do this by changing Pn920 to 2 and then to 3 again.

If this method is used with an encoder that is not absolute (Pn232<>2) Error 61.2 is generated.

6-20 Setup with Serial Converter

Outline of Operation

A Serial Converter unit can be used when:

- You want to use a SinCos Encoder.
- You want to use Hall sensor for a direct magnetic pole measurement.
- You want to use the Temperature sensor in the motor.

The servodrive only admits 2 kind of Encoder connections:

- Line Drive A/B quadrature pulses.
- G5-Serial synchronous protocol.

Both are in different pins of the CN4 connectors and are mutually exclusive depending on the setting of Pn323.

You may want to use a SinCos Encoder because this kind of encoder allows higher interpolation than the equivalent A/B Encoder. An A/B Encoder can only be interpolated by 4 while a SinCos Encoder can be interpolated by a much higher factor. The Serial Converter makes an interpolation of 400 so one encoder with a SinCos grate of 20 μ m results in a resolution of 50nm. This allows to reach high resolutions with high speed (in A/B Encoders we are limited by the bandwidth) or to use low resolution encoders (eg. magnetic encoder with a grate of 1mm).

You may want to use Hall sensors either because:

- The magnetic pole sensing is not reliable because the axis is vertical or has a high friction.
- You need very high accuracy in the measurement.

You may want to use the Temperature sensor in the drive because you cannot rely in the overload estimation in the servodrive due to the installation conditions. The linear servomotor has 2 temperature sensor, one PT100-C that is used to give the "motor temperature alarm" and a second one (NTC10k in the Ironless motor and KTY-83/121 in the Iron-core) to measure the actual temperature value as a drive monitor.

Parameters Requiring Settings

Parameter number	Parameter name	Explanation	Reference
Pn323	Encoder type	Selects the encoder type connected	P.8-33
Pn920	Magnetic pole detection method	Selects the mode to detect the magnetic pole	P.8-64

Operating Procedure

Select the Encoder type as SinCos Encoder (Pn323=1) to enable the Serial Converter Unit protocol. The drive automatically detects if the connected device is a Serial Converter Unit or a Serial Incremental Encoder.

Select Pn902=2 if Hall sensor is used.

There is no setting for Temperature sensor. If the Temperature sensors are not used, no overtemperature alarm appear and the temperature monitor will be zero.

It is possible to use SinCos Encoder without using Hall sensor or Temperature sensor but for using Hall sensor or Temperature sensors it is mandatory to use a SinCos Encoder.

The connection layout is next:

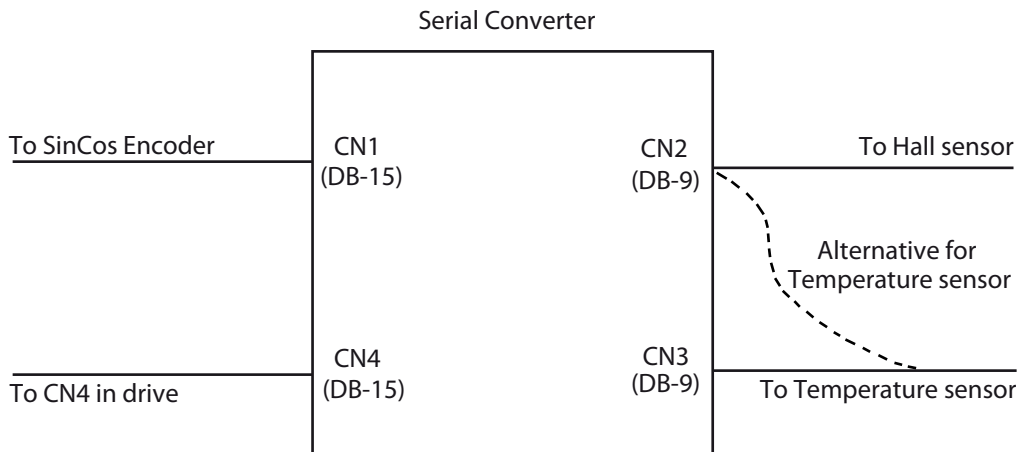

Temperature sensors can be alternatively connected to CN2 together with the Hall sensor or in CN3. The pinout is the same.

7

Safety Function

This function stops the motor based on a signal from a Safety Controller or safety sensor.

An outline of the function is explained together with operation and connection example.

7-1	Safe Force OFF (STO) Function	7-2
	Outline of Operation.....	7-2
	I/O Signal Specifications.....	7-3
7-2	Operation Example	7-5
7-3	Connection Example	7-7

7-1 Safe Force OFF (STO) Function

Outline of Operation

The safe force OFF (hereinafter referred to as STO according to IEC61800-5-2) function is used to cut off the motor current and stop the motor through the input signals from a safety equipment, such as a Safety Controller or safety sensor, that is connected to the safety connector (CN8).

When the STO function is operating, the drive turns OFF the servo ready completed output (READY) to go into the safety status.



Safety Points

- ♦ When using the STO function, be sure to execute a risk assessment of the equipment to confirm that the system safety requirements are met.
- ♦ There are following risks even when the STO function is operating. Be sure to take safety into account as part of the risk assessment.
 - The motor runs if external force is present (e.g., force of gravity on the vertical axis, etc.). If holding is required, implement appropriate measures, such as providing external brakes. Take note that the brakes for the drive with brakes are used for the holding purpose only, and cannot be used for control.
 - Even if there is no external force, when Stop Selection for Alarm Generation (Pn510) is set to free-run (with the dynamic brake disabled), the motor operates as free-run and the stop distance is long.
 - The motor may operate in the range of up to 180 degrees of electrical angle due to a power transistor trouble and so forth.
 - The power supply to the motor is cut off by the STO function, but the power supply to the drive will not be cut off nor electrically insulated. For drive maintenance, cut off the power supply to the drive through another means.
- ♦ The EDM output signal is not a safety output. Do not use it for purposes other than the failure monitoring function.
- ♦ The dynamic brake and external brake release signal output are not safety-related parts. Make sure that the equipment does not become dangerous during system design even if the external brake release fails during the STO status.
- ♦ When using the STO function, connect an equipment that meets the safety standards.
- ♦ The PFH value is 2.30×10^{-8} .
- ♦ Following certifications are fulfilled:
 - CAT-3 (EN 954-1)
 - Performance level d (EN/ISO 13849-1)
 - SIL 2 (IEC/EN 62061)
- ♦ See the Appendix in chapter 12 for servo drive safety certification

Note: Although with linear motors we have to talk about Force instead of Torque, we keep “Safe Torque OFF” as the name of this function because it is the standard name.

I/O Signal Specifications

Safety Input Signal

There are 2 types of safety input circuits to operate the STO function.

Signal name	Symbol	Pin number	Description	CONTROL mode		
				Position	Speed	Force
Safety input 1	SF+	CN8-4	• The upper arm drive signal of the power transistor inside the drive is cut off.	√	√	√
	SF-	CN8-3		√	√	√
Safety input 2	SF2+	CN8-6	• The lower arm drive signal of the power transistor inside the drive is cut off.	√	√	√
	SF2-	CN8-5		√	√	√

- When the safety input is either 1 or 2, the STO function will start operating within 5 ms of the input, and the motor output force will be turned OFF.
- Connect the equipment so that the safety input circuit is turned OFF when you operate the STO function.
- Use Stop Selection for Alarm Generation (Pn510) to set the operation when the safety input is turned OFF.

 Precautions for Correct Use

- L-pulse for self-diagnosis of safety equipment
 When you are connecting a safety equipment, such as a Safety Controller or a safety sensor, the safety output signal of the equipment may include L pulse for self-diagnosis. To avoid malfunction due to this L-pulse for self-diagnosis, a filter that can remove the L pulse for self-diagnosis is built in with the safety input circuit. If the OFF time of the safety input signal is 1 ms or less, the safety input circuit does not recognize it as OFF. To make sure that OFF is recognized, maintain the OFF status of safety input signal for at least 5 ms.

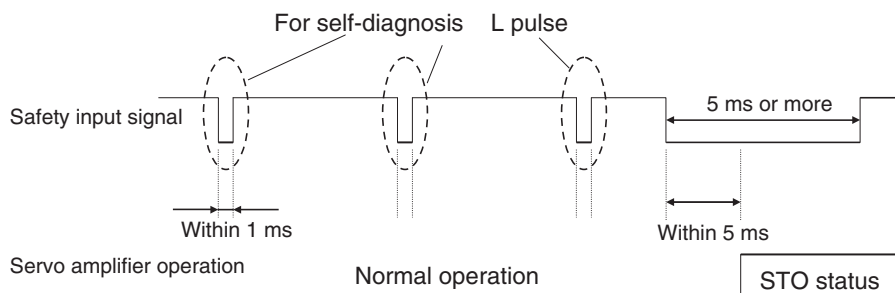

External Device Monitor (EDM) Output Signal

This is a monitor output signal that is used to monitor the status of safety input signals using an external device.

Connect a safety equipment, such as a Safety Controller or a safety sensor, to the external device monitoring terminal.

Signal name	Symbol	Pin number	Description	CONTROL mode		
				Position	Speed	Force
EDM output	EDM+	CN8-8	<ul style="list-style-type: none"> Monitor signal is output to detect malfunctioning of the safety function. * This output signal is not a safety output. 	√	√	√
	EDM-	CN8-7		√	√	√

Relationship Between Safety Input Signal and EDM Output Signal

When safety inputs 1 and 2 are both OFF (where the STO function is operating for safety inputs for the 2 circuits), the EDM output circuit is turned ON.

You can detect a failure of the safety input circuit and the EDM output circuit by monitoring all of the following 4 signal statuses using an external device.

Signal name	Symbol	Signal status			
Safety input 1	SF1	ON	ON	OFF	OFF
Safety input 2	SF2	ON	OFF	ON	OFF
EDM output	EDM	OFF	OFF	OFF	ON

- ♦ The maximum delay time is 6 ms after the safety input signal is input and until the EDM output signal is output.

7-2 Operation Example

Operation Timings to a Safety Status

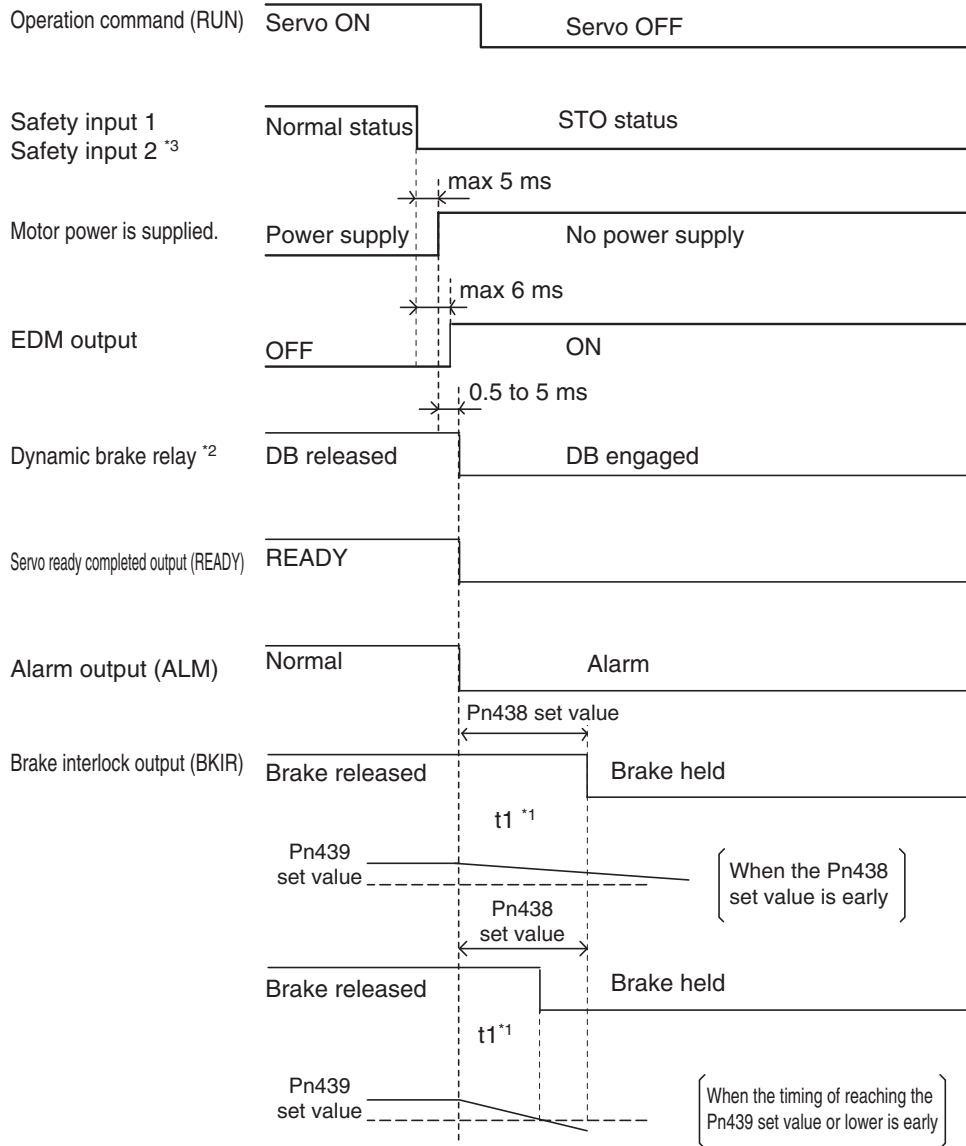

*1. $t1$ is the set value of the Brake Timing during Operation (Pn438), or the time needed for the motor speed to drop to or below the Brake Release Speed Setting (Pn439), whichever occurs first.

*2. The dynamic brake is based on the Stop Selection for Alarm Generation (Pn510) setting.

*3. Safety inputs 1 and 2 transition to the STO status when either one of them is turned OFF.

Timings of Return from the Safety Status

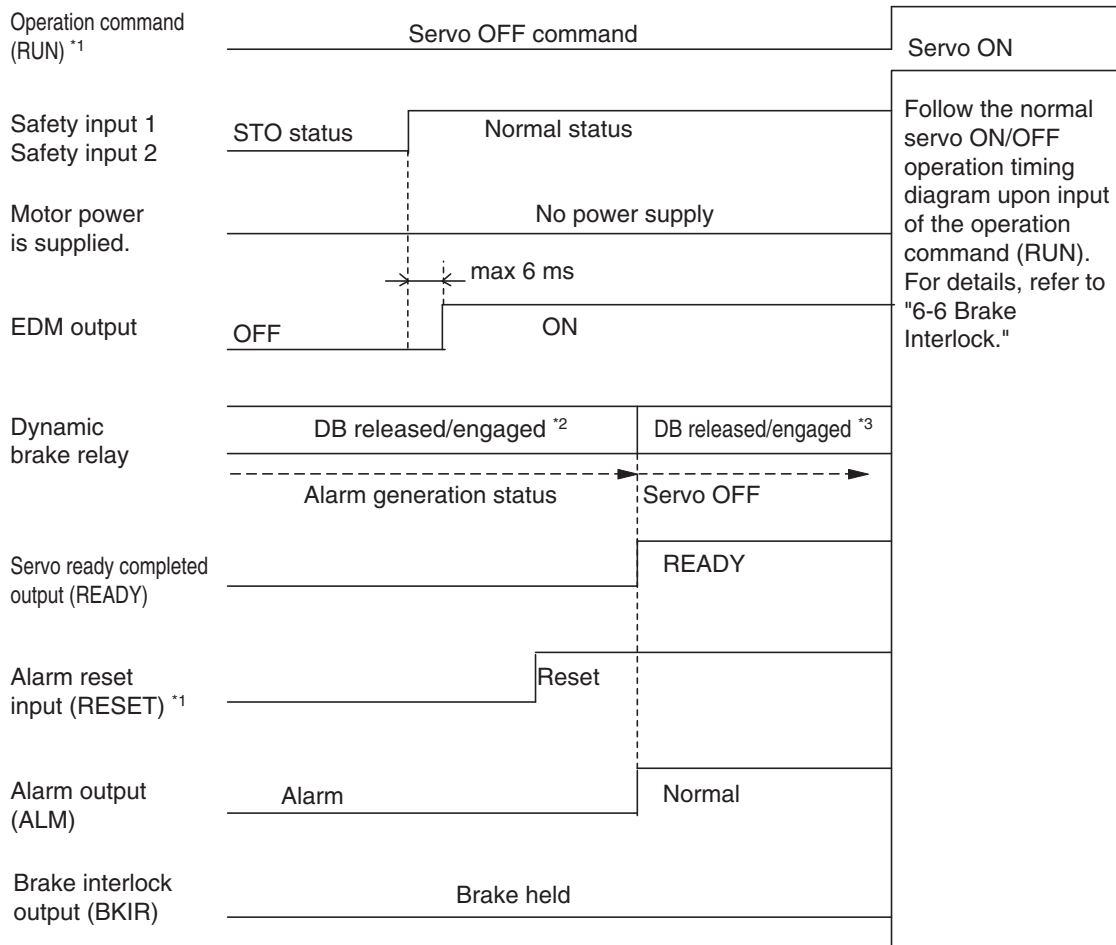

Follow the normal servo ON/OFF operation timing diagram upon input of the operation command (RUN). For details, refer to "6-6 Brake Interlock."

- *1. Make sure that servo ON input is turned OFF when you return the input signals of safety inputs 1 and 2 to ON. Alarm clear must be performed because alarms will occur. Be sure to execute the alarm clear when both safety inputs 1 and 2 are returned to the ON status. An alarm will occur immediately if the alarm reset is executed when even one of these is still in the OFF status.
- *2. Since this is a status where alarms will occur, the dynamic brake is based on the Stop Selection for Alarm Generation (Pn510).
- *3. Since this is a normal servo OFF status, the dynamic brake is based on the Stop Selection with Servo OFF (Pn506) setting.

7-3 Connection Example

Connection with a Safety Controller (2 safety input and EDM output)

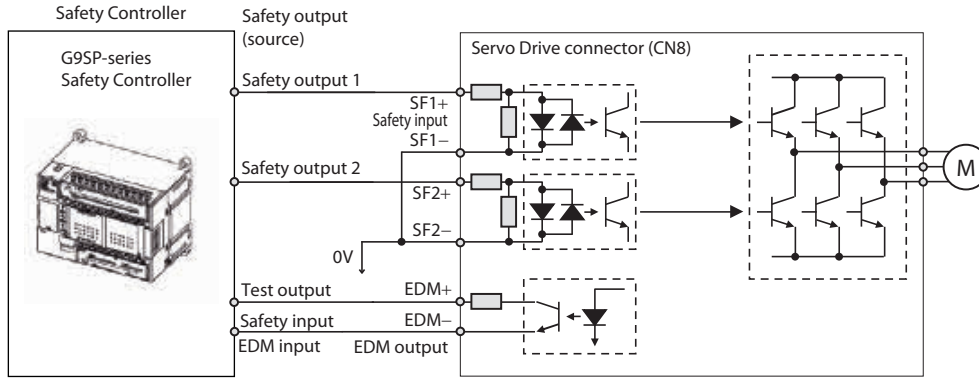

8

Parameters Details

This chapter explains the set value and contents of setting of each parameter.

8-1	Basic Parameters.....	8-2
8-2	Gain Parameters	8-9
8-3	Vibration Suppression Parameters.....	8-20
8-4	Analog Control Parameters	8-25
8-5	Interface Monitor Setting Parameters.....	8-35
8-6	Extended Parameters	8-45
8-7	Special Parameters.....	8-57
8-8	Linear Motor And Encoder Setting Parameters.....	8-62

8-1 Basic Parameters

Pn000	Movement Direction Setting						All
Setting range	0 to 1	Unit	–	Default setting	1	Power OFF and ON	Yes

Explanation of Set Values

Set value	Explanation
0	Forward direction command moves in the direction of the motor coil cables.
1	Forward direction command moves in the direction opposite to the motor coil cables.

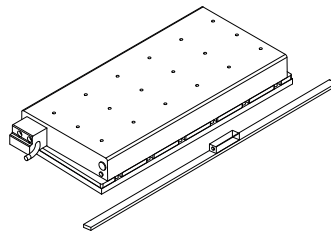

Pn001	CONTROL mode Selection						All
Setting range	0 to 5	Unit	–	Default setting	0	Power OFF and ON	Yes

Explanation of Set Values

Set value	Explanation
0	Position control (pulse train command)
1	Speed control (analog command)
2	Force control (analog command)
3	Mode 1: Position control, Mode 2: Speed control
4	Mode 1: Position control, Mode 2: Force control
5	Mode 1: Speed control, Mode 2: Force control

- ♦ Set the CONTROL mode to be used.
- ♦ If COMPOSITE modes are set (set values: 3 to 5), mode 1 or mode 2 can be selected using the CONTROL mode switching input (TVSEL).
 - When the CONTROL mode switching input is open: Select mode 1.
 - When the CONTROL mode switching input is short-circuited: Select mode 2.
- ♦ Do not input a command within 10 ms before or after switching.

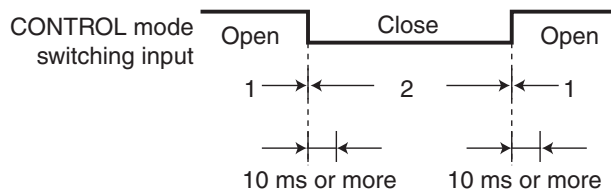

Pn002	REALTIME AUTOTUNING mode Selection						All
Setting range	0 to 6	Unit	–	Default setting	1	Power OFF and ON	–

Explanation of Set Values

Set value	Explanation
0	Disabled
1	This mode focuses on stability.
2	This mode focuses on positioning.
3	Used when unbalanced load is present as in vertical axes
4	Used when friction is large (unbalanced load also calculated).
5	Used in combination with the software tool. The drive calculates the correction and the user decides whether to apply them or not.
6	Used when freely combining REALTIME AUTOTUNING mode and APPLICABLE FILTER mode.

♦ See Chapter 10 for details.

Pn003	Realtime Autotuning Machine Rigidity Setting						All
Setting range	0 to 31	Unit	–	Default setting	13	Power OFF and ON	–

- ♦ Default settings:
 - (1) Pn003 = 11 - For 200V drives of 1Kw or upper and 400V drives
 - (2) Pn003 = 13 - For 200V drives of less than 1 Kw
- ♦ Set the machine rigidity to one of 32 levels when realtime autotuning is enabled.

Low ←Machine rigidity→ High

Low ←Servo gain→ High

Pn003	0.1 ----- 31
-------	--------------

Low ←Responsiveness→ High

- ♦ If the set value is changed suddenly by a large amount, the gain will change rapidly, subjecting the machine to shock. Always start with the small setting, and gradually increase the setting while monitoring machine operation.

Pn004	Mass Ratio						All
Setting range	0 to 10,000	Unit	%	Default setting	250	Power OFF and ON	–

- ♦ Set the load mass as a percentage of the motor rotor mass.
- ♦ $Pn004 = (\text{Load mass} / \text{Motor coil mass}) \times 100\%$
- ♦ When realtime autotuning is enabled, the mass ratio is continuously estimated and saved in EEPROM every 30 minutes.
- ♦ If the mass ratio is set correctly, the setting unit for the Speed Loop Gain (Pn101) and Speed Loop Gain 2 (Pn106) is Hz.
- ♦ If the Mass Ratio (Pn004) is set larger than the actual value, the setting for speed loop gain will increase. If the Mass Ratio (Pn004) is set smaller than the actual value, the setting for speed loop gain will decrease.



8-1 Basic Parameters

Pn005	Command Pulse Input Selection						Position
Setting range	0 to 1	Unit	–	Default setting	0	Power OFF and ON	Yes

Explanation of Set Values

Set value	Explanation
0	Photocoupler input (+PULS: CN1 pin 3, -PULS: CN1 pin 4, +SIGN: CN1 pin 5, -SIGN: CN1 pin 6)
1	Input for line drive only (+CWLD: CN1 pin 44, -CWLD: CN1 pin 45, +CCWLD: CN1 pin 46, -CCWLD: CN1 pin 47)

- ♦ Selects whether to use photocoupler or input for line drive only for the command pulse input.

Pn006	Command Pulse Direction Switching Selection						Position
Setting range	0 to 1	Unit	–	Default setting	0	Power OFF and ON	Yes

Explanation of Set Values

Set value	Explanation
0	The motor moves in the direction specified by the command pulse.
1	The motor moves in the opposite direction specified by the command pulse.

- ♦ Set the motor movement direction for the command pulse input.

Pn007	COMMAND PULSE mode Selection						Position
Setting range	0 to 3	Unit	–	Default setting	1	Power OFF and ON	Yes

- ♦ Set the count method for the command pulse input.

Command Pulse Direction Switching Selection (Pn006)	COMMAND PULSE mode Setting (Pn007)	COMMAND PULSE mode	Motor forward command	Motor reverse command
0	0 or 2	90° phase difference (phases A and B) signal inputs	<p>Line drive: $t_1 \geq 2 \mu\text{s}$ Open collector: $t_1 \geq 5 \mu\text{s}$</p>	<p>Line drive: $t_1 \geq 2 \mu\text{s}$ Open collector: $t_1 \geq 5 \mu\text{s}$</p>
	1	Reverse pulse/forward pulse	<p>Line drive: $t_2 \geq 1 \mu\text{s}$ Open collector: $t_2 \geq 2.5 \mu\text{s}$</p>	<p>Line drive: $t_2 \geq 1 \mu\text{s}$ Open collector: $t_2 \geq 2.5 \mu\text{s}$</p>
	3	Feed pulse/direction signal	<p>Line drive: $t_2 \geq 1 \mu\text{s}$ Open collector: $t_2 \geq 2.5 \mu\text{s}$</p>	<p>Line drive: $t_2 \geq 1 \mu\text{s}$ Open collector: $t_2 \geq 2.5 \mu\text{s}$</p>
1	0 or 2	90° phase difference (phases A and B) signal inputs	<p>Line drive: $t_1 \geq 2 \mu\text{s}$ Open collector: $t_1 \geq 5 \mu\text{s}$</p>	<p>Line drive: $t_1 \geq 2 \mu\text{s}$ Open collector: $t_1 \geq 5 \mu\text{s}$</p>
	1	Reverse pulse/forward pulse	<p>Line drive: $t_2 \geq 1 \mu\text{s}$ Open collector: $t_2 \geq 2.5 \mu\text{s}$</p>	<p>Line drive: $t_2 \geq 1 \mu\text{s}$ Open collector: $t_2 \geq 2.5 \mu\text{s}$</p>
	3	Feed pulse/direction signal	<p>Line drive: $t_2 \geq 1 \mu\text{s}$ Open collector: $t_2 \geq 2.5 \mu\text{s}$</p>	<p>Line drive: $t_2 \geq 1 \mu\text{s}$ Open collector: $t_2 \geq 2.5 \mu\text{s}$</p>

- ♦ Set the form of the pulse inputs sent as command to the drive from a Position Controller.
- ♦ Modes 0 and 2 are exactly the same.



8-1 Basic Parameters

Pn009	Electronic Ratio Numerator 1						Position
Setting range	1 to 1073741824	Unit	–	Default setting	10000	Power OFF and ON	–

Pn010	Electronic Ratio Denominator						Position
Setting range	1 to 1073741824	Unit	–	Default setting	10000	Power OFF and ON	–

- ♦ Set the electronic ratio function.
- ♦ The electronic ratio can be used for the following:
 - To set the amount of travel distance per input command pulse.
 - To increase the nominal command pulse frequency by using a multiplier when the desired motor speed cannot be achieved due to the limited pulse generation capability of the host device (possible maximum output frequency).
- ♦ Electronic Ratio Block Diagram:

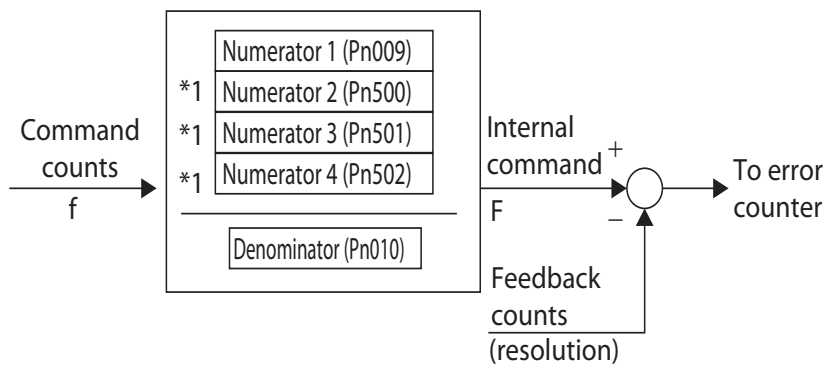

*1. Numerator 2 to 4 is selected using the electronic ratio switching (GESEL1 and GESEL2).

GESEL1	GESEL2	Selected numerator
OFF	OFF	Electronic Ratio Numerator 1
ON	OFF	Electronic Ratio Numerator 2
OFF	ON	Electronic Ratio Numerator 3
ON	ON	Electronic Ratio Numerator 4

- ♦ The electronic ratio is set using the following equation.

$$\text{Electronic ratio} = \frac{\text{Electronic Ratio Numerator (Pn009, Pn500, Pn501 and Pn502)}}{\text{Electronic Ratio Denominator (Pn010)}}$$









Pn011	Encoder Dividing Numerator						All
Setting range	1 to 262,144	Unit	–	Default setting	2500	Power OFF and ON	Yes

- ♦ Note that 1 pulse corresponds to 4 counts. Encoder resolution corresponds with counts.
- ♦ This parameter is used together with Pn503 to define the ratio between encoder feedback pulses to encoder output pulses. The encoder output resolution correspond to the next formula:

$$\text{Encoder pulse} \rightarrow \frac{\text{Pn 011}}{\text{Pn 503}} \rightarrow \text{Output pulse}$$

Pn012	Encoder Output Direction Switching Selection						All
Setting range	0 to 3	Unit	–	Default setting	0	Power OFF and ON	Yes

Explanation of Set Values

Set value	Phase B logic	Motor forward command	Motor reverse command
0,2	Non-reverse	Phase A  Phase B 	Phase A  Phase B 
1,3	Reverse	Phase A  Phase B 	Phase A  Phase B 

Pn013	No. 1 Force Limit						All
Setting range	0 to 500	Unit	% of nominal	Default setting	500	Power OFF and ON	–

- ♦ Set the No. 1 limit value for the output force of the motor.
- ♦ Set the first limit of the motor output force as percentatge of the motor nominal force. Regardless of the setting of this parameter the maximum force is limited by the motor characteristics.

Pn014	Error Counter Overflow Level						Position
Setting range	0 to 134217728	Unit	Command unit	Default setting	100000	Power OFF and ON	–

- ♦ Set the range of the error counter overflow level.



8-1 Basic Parameters

Pn016	Regeneration Resistor Selection							All
Setting range	0 to 3	Unit	–	Default setting	3	Power OFF and ON	Yes	

♦ Default settings:

- (1) Pn016 = 0 - For 200V drives of 750 W or upper and 400V drives
- (2) Pn016 = 3 - For 200V drives of less than 750 W

Explanation of Set Values

Set value	Explanation
0	Regeneration Resistor used: Built-in Resistor The regeneration processing circuit will operate and the regeneration overload (alarm display No. 18) will be enabled according to the Built-in Resistor (with approx. 1% duty).
1	Regeneration Resistor used: External Resistor The regeneration processing circuit will operate, and regeneration overload (alarm display No. 18) will cause a trip when the operating rate of the Regeneration Resistor exceeds 10%.
2	Regeneration Resistor used: External Resistor The regeneration processing circuit will operate, but regeneration overload (alarm display No. 18) will not occur.
3	Regeneration Resistor used: None The regeneration processing circuit and regeneration overload (alarm display No. 18) will not operate, and all regenerative energy will be processed by the built-in capacitor.

- ♦ Do not touch the External Regeneration Resistor. A burn injury may result.
- ♦ Always provide a temperature fuse or other protective measure when using an External Regeneration Resistor. Regardless of whether the regeneration overload is enabled or disabled, the Regeneration Resistor can generate heat and may cause burning.
- ♦ Set this parameter depending on whether the Built-in Regeneration Resistor is used, or the Built-in Regeneration Resistor is disconnected and an External Regeneration Resistor is connected. (The External Regeneration Resistor connection terminal is connected.)
- ♦ To use the Built-in Regeneration Resistor, always set this parameter to 0.

Pn017	External Regeneration Resistor Setting							All
Setting range	0 to 4	Unit	–	Default setting	0	Power OFF and ON	Yes	

Explanation of Set Values

Set value	Explanation
0	Regeneration load ratio is 100% when operating rate of the External Regeneration Resistor is 10%.
1	Reserved
2	Reserved
3	Reserved
4	Reserved

8-2 Gain Parameters

Pn100	Position Loop Gain						Position
Setting range	0 to 30,000	Unit	0.1/s	Default setting	480	Power OFF and ON	-

- ♦ Default settings:
 - (1) Pn100 = 320 - For 200V drives of 1Kw or upper and 400V drives
 - (2) Pn100 = 480 - For 200V drives of less than 1 Kw
 - ♦ Adjust the position loop response to suit the machine rigidity.
 - ♦ The responsiveness of the linear servo system is determined by the position loop gain. Linear Servo systems with a high position loop gain have a high responsiveness and fast positioning. To increase the position loop gain, you must improve machine rigidity and increase the specific vibration frequency.
 - ♦ Increasing the position loop gain in systems with low machine rigidity or systems with low specific vibration frequencies may cause machine resonance, resulting in an overload alarm.
 - ♦ If the position loop gain is low, you can shorten the positioning time using feed forward.
 - ♦ This parameter is automatically changed by executing realtime autotuning function. To set it manually, set the REALTIME AUTOTUNING mode Selection (Pn002) to 0.
- Position loop gain is generally expressed as follows:

$$\text{Position loop gain (Kp)} = \frac{\text{Command pulse frequency (pulse/s)}}{\text{Error counter accumulated pulse (pulse)}} \quad (0.1/s)$$

Response when the position loop gain is operated

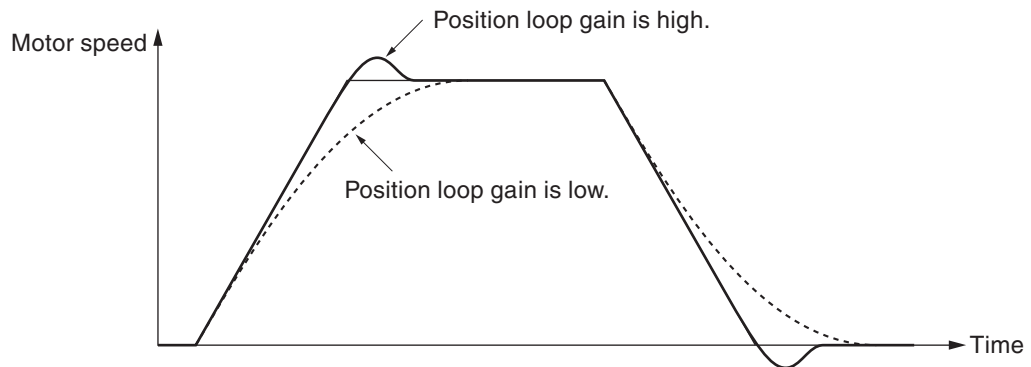

- ♦ If the speed loop gain and position loop gain are optimally set, the motor operation for the command will be delayed $2/Kp$ at acceleration and delayed $3/Kp$ at deceleration.

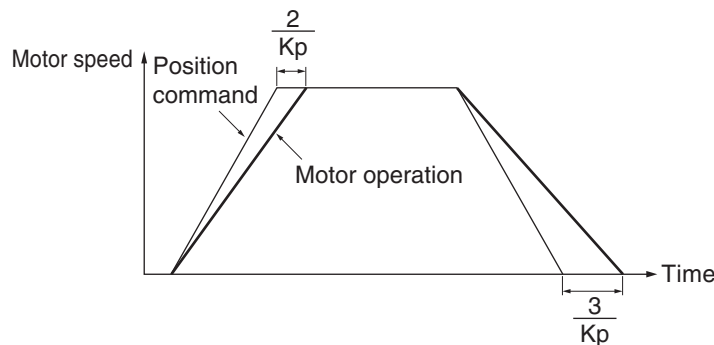

8-2 Gain Parameters

Pn101	Speed Loop Gain						All
Setting range	1 to 32,767	Unit	0.1 Hz	Default setting	270	Power OFF and ON	-

♦Default settings:

- (1) Pn101 = 180 - For 200V drives of 1Kw or upper and 400V drives
- (2) Pn101 = 270 - For 200V drives of less than 1 Kw

♦Determine speed loop responsiveness.

♦The setting for the speed loop gain must be increased to increase the position loop gain and improve the responsiveness of the entire linear servo system. Setting too high, however, may result in vibration.

♦The setting unit for Pn101 will be Hz if the Mass Ratio (Pn004) is set correctly.

When the speed loop gain is changed, the response is as shown in the following diagram.

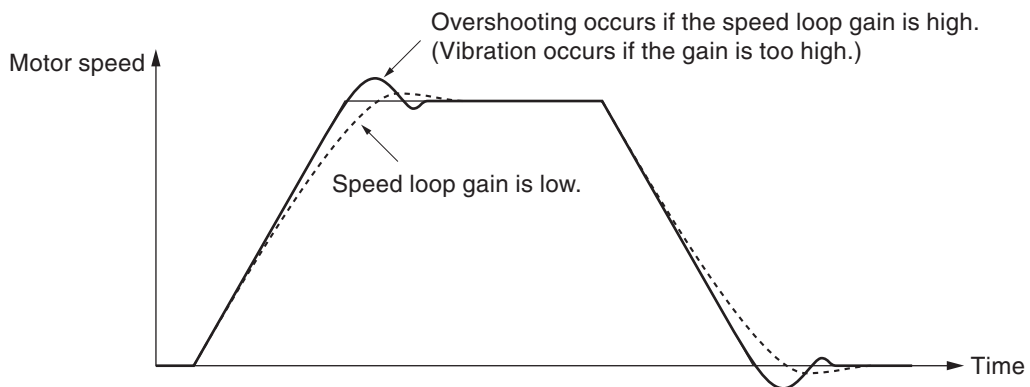

Pn102	Speed Loop Integral Time Constant						All
Setting range	1 to 10,000	Unit	0.1 ms	Default setting	210	Power OFF and ON	-

♦Default settings:

- (1) Pn102 = 310 - For 200V drives of 1Kw or upper and 400V drives
- (2) Pn102 = 210 - For 200V drives of less than 1 Kw

♦ Set the speed loop integration time constant.

♦ The smaller the set value, the faster the error will come close to 0 when stopping. Set to 9,999 to maintain integration. Set to 10,000 to invalidate the effect of integration.

When the speed loop integral time constant is changed, the response is as shown in the following diagram.

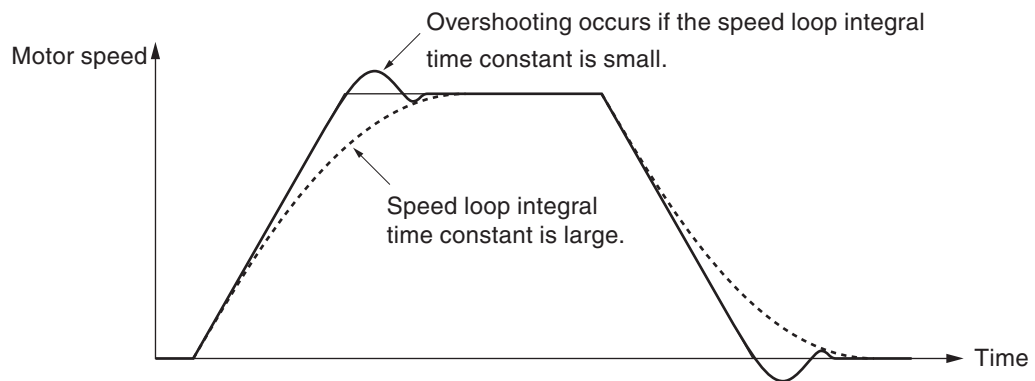

Pn103	Speed Feedback Filter Time Constant							All
Setting range	0 to 5	Unit	–	Default setting	0	Power OFF and ON	–	

- ♦ Set the time constant for the low pass filter (LPF) after speed detection to one of 6 levels (0 to 5).
- ♦ Increasing the set value increases the time constant and decreases the noise generated by the motor. Responsiveness, however, also decreases.
- ♦ Normally, use the default set value.

Pn104	Force Command Filter Time Constant							All
Setting range	0 to 2,500	Unit	0.01 ms	Default setting	84	Power OFF and ON	–	

- ♦ Default settings:
 - (1) Pn104 = 126 - For 200V drives of 1Kw or upper and 400V drives
 - (2) Pn104 = 84 - For 200V drives of less than 1 Kw
- ♦ Set the time constant for the first-order lag filter inserted into the force command.
- ♦ This parameter may be effective in suppressing vibration due to torsion resonance.

Pn105	Position Loop Gain 2							Position
Setting range	1 to 30,000	Unit	0.1/s	Default setting	570	Power OFF and ON	–	

- ♦ Default settings:
 - (1) Pn105 = 380 - For 200V drives of 1Kw or upper and 400V drives
 - (2) Pn105 = 570 - For 200V drives of less than 1 Kw
- ♦ Set the responsiveness of the position control system for the second position loop.

Pn106	Speed Loop Gain 2							All
Setting range	1 to 32,767	Unit	0.1 Hz	Default setting	270	Power OFF and ON	–	

- ♦ Default settings:
 - (1) Pn106 = 180 - For 200V drives of 1Kw or upper and 400V drives
 - (2) Pn106 = 270 - For 200V drives of less than 1 Kw
- ♦ Set the responsiveness of the second speed loop.

Pn107	Speed Loop Integration Time Constant 2							All
Setting range	1 to 10,000	Unit	0.1 ms	Default setting	10000	Power OFF and ON	–	

- ♦ Set the second speed loop integration time constant.

Pn108	Speed Feedback Filter Time Constant 2							All
Setting range	0 to 5	Unit	–	Default setting	0	Power OFF and ON	–	

- ♦ Set the second speed feedback filter.

8-2 Gain Parameters

Pn109	Force Command Filter Time Constant 2							All	
Setting range	0 to 2,500	Unit	0.01 ms	Default setting	84	Power OFF and ON	-		
<ul style="list-style-type: none"> ♦ Default settings: <ul style="list-style-type: none"> (3) Pn109 = 126 - For 200V drives of 1Kw or upper and 400V drives (4) Pn109 = 84 - For 200V drives of less than 1 Kw ♦ Set the second force filter time constant. ♦ The parameters from Pn105 to Pn109 are the gain and time constants to be selected when the GAIN SWITCHING INPUT OPERATING mode Selection (Pn114) is enabled. ♦ The gains are switched according to the condition set in the GAIN SWITCHING mode (Pn115, Pn120 and Pn124). ♦ If the mechanical system mass changes greatly or if you want to change the responsiveness depending on whether the motor is moving or being stopped, you can achieve the appropriate control by setting the gains and time constants beforehand for each of these conditions, and switching them according to the condition. ♦ This parameter is automatically changed by executing realtime autotuning function. To set it manually, set the REALTIME AUTOTUNING mode Selection (Pn002) to 0. 									
Pn110	Speed Feed-forward Amount							Position	
Setting range	0 to 1,000	Unit	0.1%	Default setting	300	Power OFF and ON	-		
<ul style="list-style-type: none"> ♦ Set the feed-forward amount. Increasing the set value decreases the position error and increases the responsiveness. Overshooting, however, will occur more easily. ♦ If autotuning is enabled this is fixed to default value. 									
Pn111	Speed Feed-forward Command Filter							Position	
Setting range	0 to 6,400	Unit	0.01 ms	Default setting	50	Power OFF and ON	-		
<ul style="list-style-type: none"> ♦ Set the time constant for the first-order lag filter inserted into the feed forward. ♦ Setting the filter may improve operation if speed overshooting occurs or the noise during operation is large when the feed forward is set high. 									
Pn112	Force Feed-forward Amount							Position	Speed
Setting range	0 to 1,000	Unit	0.1%	Default setting	0	Power OFF and ON	-		
<ul style="list-style-type: none"> ♦ Set the feed-forward amount to the force loop. Increasing the set value decreases the position error during acceleration and increases the responsiveness but the system may become more noisy. 									
Pn113	Force Feed-forward Command Filter							Position	Speed
Setting range	0 to 6,400	Unit	0.01 ms	Default setting	0	Power OFF and ON	-		
<ul style="list-style-type: none"> ♦ Set the time constant for the first-order lag filter inserted into the feed forward. ♦ Setting the filter may improve operation if the noise during operation is large when the feedforward is set high. ♦ If autotuning is enabled, feedforward gain and filter are set at a fixed value. 									
Pn114	GAIN SWITCHING INPUT OPERATING mode Selection							All	
Setting range	0 to 1	Unit	-	Default setting	1	Power OFF and ON	-		

Explanation of Set Values

Set value	Explanation
0	Gain 1 (PI/P switching enabled)
1	Gain 1/gain 2 switching available

- ♦ Select either PI/P operation switching or gain 1/gain 2 switching.
- ♦ PI/P operation switching is performed using gain switching (GSEL: CN1 pin 27). PI is not changed, however, if the Force Limit Selection (Pn521) is set to 3.

Gain input	Speed loop operation
GSEL OFF	PI operation
GSEL ON	P operation

- ♦ For information on switching conditions between gain 1 and gain 2, refer to "Gain Switching Function" (P.6-23)

Pn115	SWITCHING mode in Position Control						Position
Setting range	0 to 10	Unit	–	Default setting	0	Power OFF and ON	–

Explanation of Settings

(√: Enabled, –: Disabled)

Set value	Explanation			
	Gain switching conditions	Gain Switching Delay Time in Position Control (Pn116) ^{*1}	Gain Switching Level in Position Control (Pn117)	Gain Switching 1 Hysteresis in Position Control (Pn118) ^{*2}
0	Always Gain 1 (Pn100 to Pn104)	–	–	–
1	Always Gain 2 (Pn105 to Pn109)	–	–	–
2	Switching using gain switching input (GSEL) for CN1 pin 27	–	–	–
3	Force command level (Refer to Figure A)	√	√ ^{*3} (× 0.05%)	√ ^{*3} (× 0.05%)
4	Always Gain 1 (Pn100 to Pn104)	–	–	–
5	Command speed (Refer to Figure B)	√	√ (mm/s)	√ (mm/s)
6	Amount of position error (Refer to Figure C)	√	√ ^{*4} (pulse)	√ ^{*4} (pulse)
7	Position command received (Refer to Figure D)	√	–	–
8	Positioning completion signal (INP) OFF (Refer to Figure E)	√	–	–
9	Actual motor speed (Refer to Figure B)	√	√ (mm/s)	√ (mm/s)
10	Combination of command received and speed (Refer to Figure F)	√	√ ^{*5} (mm/s)	√ ^{*5} (mm/s)

8-2 Gain Parameters

- ♦ Select the conditions for switching between gain 1 and gain 2 when the GAIN SWITCHING INPUT OPERATING mode Selection (Pn114) is set to 1.
- ♦ The gain is always gain 1 regardless of the gain input if the Gain Switch input is not assigned to any input if this setting is 2.

*1. The Gain Switching Delay Time in Position Control (Pn116) is enabled when returning from gain 2 to gain 1.

*2. The Gain Switching Hysteresis in Position Control (Pn118) is defined as shown in the following figure.

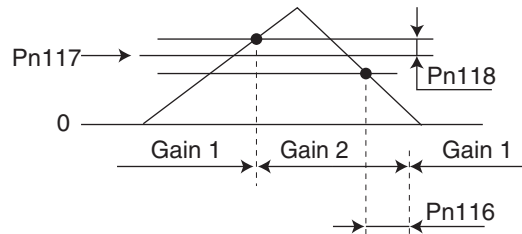

*3. The change amount is the change in 1ms.

[Example] When the condition is a 10% change in force in 1 ms, the set value is 200.

*4. This is the encoder resolution.

*5. The meanings of the gain switching delay time in position control, gain switching level in position control, and gain switching hysteresis in position control are different from normal if this is set to 10. (Refer to Figure F)

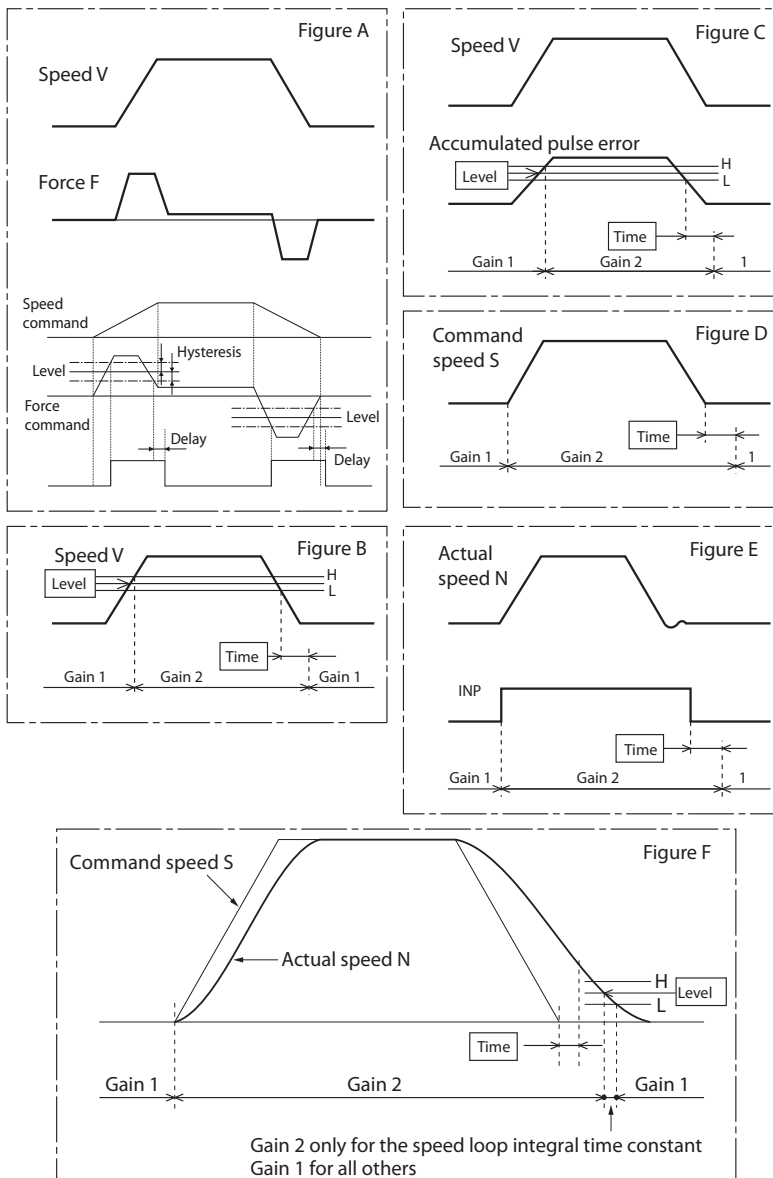

Pn116	Gain Switching Delay Time in Position Control						Position
Setting range	0 to 10,000	Unit	0.1 ms	Default setting	50	Power OFF and ON	-

- ◆ Set the delay time when returning from gain 2 to gain 1 if the SWITCHING mode in Position Control (Pn115) is set to 3 or 5 to 10.

Pn117	Gain Switching Level in Position Control						Position
Setting range	0 to 20,000	Unit	-	Default setting	50	Power OFF and ON	-

- ◆ This is enabled when the SWITCHING mode in Position Control (Pn115) is set to 3, 5, 6, 9 or 10. It sets the judgment level for switching between gain 1 and gain 2. The unit depends on the SWITCHING mode in Position Control (Pn115).

Pn118	Gain Switching Hysteresis in Position Control						Position
Setting range	0 to 20,000	Unit	-	Default setting	33	Power OFF and ON	-

- ◆ Set the hysteresis width above and below the judgment level set in the Gain Switching Level in Position Control (Pn117). The unit depends on the setting of the SWITCHING mode in Position Control (Pn115).
The following shows the definitions for the Gain Switching Delay Time in Position Control (Pn116), Gain Switching Level in Position Control (Pn117), and Gain Switching Hysteresis in Position Control (Pn118).

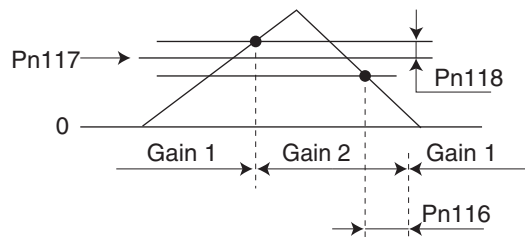

- ◆ The settings for the Gain Switching Level in Position Control (Pn117) and the Gain Switching Hysteresis in Position Control (Pn118) are enabled as absolute values (positive/negative).

Pn119	Position Gain Switching Time						Position
Setting range	0 to 10,000	Unit	0.1 ms	Default setting	33	Power OFF and ON	-

- ◆ When switching between gain 1 and gain 2 is enabled, set the rate of change for position loop gain when gain switching is executed.

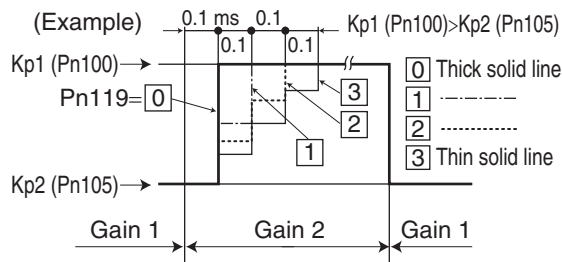

8-2 Gain Parameters

Pn120	SWITCHING mode in Speed Control						Speed
Setting range	0 to 5	Unit	–	Default setting	0	Power OFF and ON	–

Explanation of Settings

(√: Enabled, -: Disabled)

Set value	Explanation			
	Gain switching conditions	Gain Switching Delay Time in Speed Control (Pn121) *1	Gain Switching Level in Speed Control (Pn122)	Gain Switching Hysteresis in Speed Control (Pn123) *2
0	Always Gain 1 (Pn100 to Pn104)	–	–	–
1	Always Gain 2 (Pn105 to Pn109)	–	–	–
2	Switching using gain switching input (GSEL) for CN1 pin 27	–	–	–
3	Force command level (Refer to Figure A)	√	√ *3 (0.05%)	√ *3 (0.05%)
4	Amount of change in speed command (Refer to Figure B)	√	√ *4 (10 mm/s/s)	√ *4 (10 mm/s/s)
5	Speed command (Refer to Figure C)	√	√ (mm/s)	√ (mm/s)

* Select the conditions for switching between gain 1 and gain 2 when the GAIN SWITCHING INPUT OPERATING mode Selection (Pn114) is set to 1.

* The gain is always gain 1 regardless of the gain input if the SWITCHING input is not assigned when Pn120 = 2.

*1. The Gain Switching Delay Time in Speed Control (Pn121) is enabled when returning from gain 2 to gain 1.

*2. The Gain Switching Hysteresis in Speed Control (Pn123) is defined as shown in the following figure.

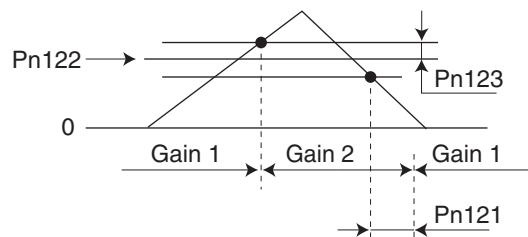

*3. The change amount is the value within 1 ms.

[Example] When the condition is a 10% change in force in 1 ms, the set value is 200.

*4. The meanings of the Gain Switching Delay Time in Speed Control (Pn121), Gain Switching Level in Speed Control (Pn122), and Gain Switching Hysteresis in Speed Control (Pn123) are different from normal if this is set to 10. (Refer to Figure B)

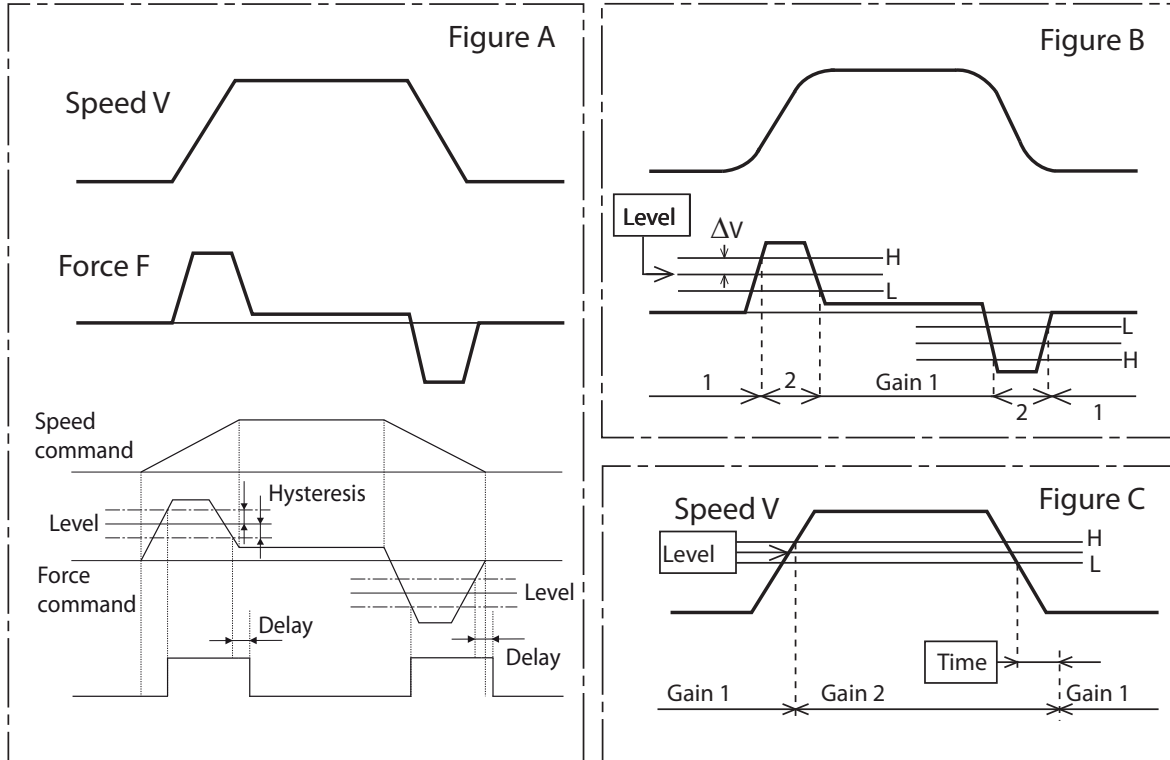

Pn121	Gain Switching Delay Time in Speed Control					Speed	
Setting range	0 to 10,000	Unit	0.1 ms	Default setting	0	Power OFF and ON	-

- ◆ Set the delay time when returning from gain 2 to gain 1 if the SWITCHING mode in Speed Control (Pn120) is set to 3 to 5.

Pn122	Gain Switching Level in Speed Control					Speed	
Setting range	0 to 20,000	Unit	-	Default setting	0	Power OFF and ON	-

- ◆ In SPEED CONTROL mode, this is enabled when the SWITCHING mode in Speed Control (Pn120) is set to 3 to 5. Set the judgment level for switching between gain 1 and gain 2. The unit depends on the SWITCHING mode in Speed Control (Pn120).

Pn123	Gain Switching Hysteresis in Speed Control					Speed	
Setting range	0 to 20,000	Unit	-	Default setting	0	Power OFF and ON	-

- ◆ Set the hysteresis width above and below the judgment level set in the Gain Switching Level in Speed Control (Pn122). The unit depends on the setting of the SWITCHING mode in Speed Control (Pn120). The following shows the definitions for the Gain Switching Delay Time in Speed Control (Pn121), Gain Switching Level in Speed Control (Pn122), and Gain Switching Hysteresis in Speed Control (Pn123).

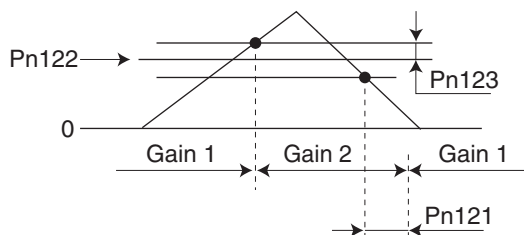

- ◆ The settings for the Gain Switching Level in Speed Control (Pn122) and the Gain Switching Hysteresis in Speed Control (Pn123) are enabled absolute values (positive/negative).

8-2 Gain Parameters

Pn124	SWITCHING mode in Force Control						Force
Setting range	0 to 3	Unit	–	Default setting	0	Power OFF and ON	–

Explanation of Settings

Set value	Explanation			
	Gain switching conditions	Gain Switching Delay Time in Force Control (Pn125) *1	Gain Switching Level in Force Control (Pn126)	Gain Switching Hysteresis in Force Control (Pn127) *2
0	Always Gain 1 (Pn100 to Pn104)	–	–	–
1	Always Gain 2 (Pn105 to Pn109)	–	–	–
2	Switching using gain switching input (GSEL) for CN1 pin 27	–	–	–
3	Force command level (Refer to Figure A)	√	√ *3 (0.05%)	√ *3 (0.05%)

♦ Select the switching condition between gain 1 and gain 2 when the Gain 2 Setting (Pn114) is set to 1.

♦ The gain is always gain 1 regardless of the gain input if the switching input is not assigned when Pn124=2.

*1. The Gain Switching Delay Time in Force Control (Pn125) is enabled when returning from gain 2 to gain 1.

*2. The Gain Switching Hysteresis in Force Control (Pn127) is defined as shown in the following figure.

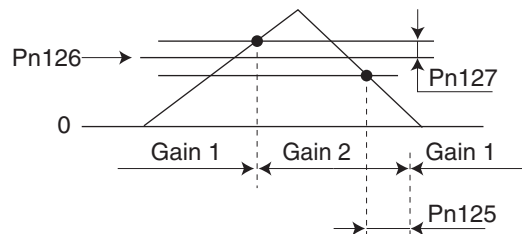

*3. The change amount is the value within 1 ms.

[Example] When the condition is a 10% change in force in 1 ms, the set value is 200.

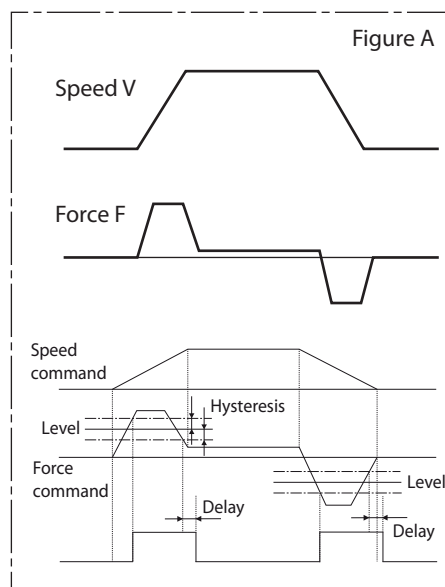

Pn125	Gain Switching Delay Time in Force Control						Force
Setting range	0 to 10,000	Unit	0.1 ms	Default setting	0	Power OFF and ON	–

- ♦ Set the delay time when returning from gain 2 to gain 1 if the SWITCHING mode in Force Control (Pn124) is set to 3.

Pn126	Gain Switching Level in Force Control						Force
Setting range	0 to 20,000	Unit	–	Default setting	0	Power OFF and ON	–

- ♦ This is enabled when the SWITCHING mode in Force Control (Pn124) is set to 3. It sets the judgment level for switching between gain 1 and gain 2. The unit depends on the setting of SWITCHING mode in Force Control (Pn124).

Pn127	Gain Switching Hysteresis in Force Control						Force
Setting range	0 to 20,000	Unit	–	Default setting	0	Power OFF and ON	–

- ♦ Set the hysteresis width above and below the judgment level set in the Gain Switching Level in Force Control (Pn126). The unit depends on the setting of SWITCHING mode in Force Control (Pn124).

The following shows the definitions for the Gain Switching Delay Time in Force Control (Pn125), Gain Switching Level in Force Control (Pn126), and Gain Switching Hysteresis in Force Control (Pn127).

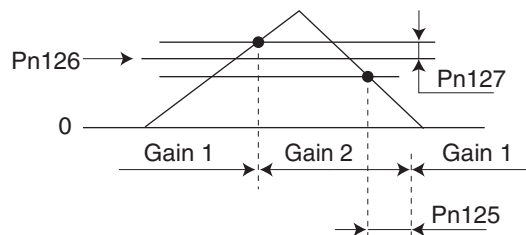

- ♦ The settings for the Gain Switching Level in Force Control (Pn126) and the Gain Switching Hysteresis in Force Control (Pn127) are enabled as absolute values (positive/negative).

8-3 Vibration Suppression Parameters

Pn200	Adaptive Filter Selection						<input type="checkbox"/> Position	<input type="checkbox"/> Speed
Setting range	0 to 4	Unit	–	Default setting	0	Power OFF and ON	–	

Explanation of Set Values

Set value	Explanation
0	Disabled. The current values are held for the parameters related to notch filters 3 and 4.
1	1 enabled. The parameter related to notch filter 3 is updated based on the applicable result.
2	2 enabled. The parameters related to notch filters 3 and 4 are updated based on the applicable result.
3	The resonance frequency is measured. The measurement result can be checked using CX-Drive. The current values are held for the parameters related to notch filters 3 and 4.
4	Adaptive result is deared. Parameters related to notch filters 3 and 4 are disabled and the adaptive result is deared.

- ◆ Set the operation of the adaptive filter.
- ◆ The adaptive filter is normally disabled in the FORCE CONTROL mode.

Pn201	Notch 1 Frequency Setting						<input type="checkbox"/> All
Setting range	50 to 5,000	Unit	Hz	Default setting	5000	Power OFF and ON	–

- ◆ Set the frequency of resonance suppression notch filter 1.
- ◆ The notch filter function will be disabled if this parameter is set to 5,000.

Pn202	Notch 1 Width Setting						<input type="checkbox"/> All
Setting range	0 to 20	Unit	–	Default setting	2	Power OFF and ON	–

- ◆ Set the width of resonance suppression notch filter 1 to one of 20 levels.
- ◆ Increasing the setting widens the notch width. Normally, use the default set value.

Pn203	Notch 1 Depth Setting						<input type="checkbox"/> All
Setting range	0 to 99	Unit	–	Default setting	0	Power OFF and ON	–

- ◆ Set the notch depth of resonance suppression notch filter 1.
- ◆ Increasing the setting will shorten the notch depth and the phase lag.

Pn204	Notch 2 Frequency Setting						<input type="checkbox"/> All
Setting range	50 to 5,000	Unit	Hz	Default setting	5000	Power OFF and ON	–

- ◆ Set the notch frequency of resonance suppression notch filter 2.
- ◆ The notch filter function will be disabled if this parameter is set to 5,000.

Pn205	Notch 2 Width Setting						<input type="checkbox"/> All
Setting range	0 to 20	Unit	–	Default setting	2	Power OFF and ON	–

- ◆ Select the notch width of resonance suppression notch filter 2.
- ◆ Increasing the setting widens the notch width. Normally, use the default set value.

Parameters Details

8-3 Vibration Suppression Parameters

Pn206	Notch 2 Depth Setting						All
Setting range	0 to 99	Unit	–	Default setting	0	Power OFF and ON	–
<ul style="list-style-type: none"> ♦ Set the notch depth of resonance suppression notch filter 2. ♦ Increasing the setting will shorten the notch depth and the phase lag. 							
Pn207	Notch 3 Frequency Setting						All
Setting range	50 to 5,000	Unit	Hz	Default setting	5000	Power OFF and ON	–
<ul style="list-style-type: none"> ♦ Set the notch frequency of resonance suppression notch filter 3. ♦ The notch filter function will be disabled if this parameter is set to 5,000. 							
Pn208	Notch 3 Width Setting						All
Setting range	0 to 20	Unit	–	Default setting	2	Power OFF and ON	–
<ul style="list-style-type: none"> ♦ Select the notch width of resonance suppression notch filter 3. ♦ Increasing the setting widens the notch width. Normally, use the default set value. 							
Pn209	Notch 3 Depth Setting						All
Setting range	0 to 99	Unit	–	Default setting	0	Power OFF and ON	–
<ul style="list-style-type: none"> ♦ Set the notch depth of resonance suppression notch filter 3. ♦ Increasing the setting will shorten the notch depth and the phase lag. 							
Pn210	Notch 4 Frequency Setting						All
Setting range	50 to 5,000	Unit	Hz	Default setting	5000	Power OFF and ON	–
<ul style="list-style-type: none"> ♦ Set the notch frequency of resonance suppression notch filter 4. ♦ The notch filter function will be disabled if this parameter is set to 5,000. 							
Pn211	Notch 4 Width Setting						All
Setting range	0 to 20	Unit	–	Default setting	2	Power OFF and ON	–
<ul style="list-style-type: none"> ♦ Select the notch width of resonance suppression notch filter 4. ♦ Increasing the setting widens the notch width. Normally, use the default set value. 							
Pn212	Notch 4 Depth Setting						All
Setting range	0 to 99	Unit	–	Default setting	0	Power OFF and ON	–
<ul style="list-style-type: none"> ♦ Set the notch depth of resonance suppression notch filter 4. ♦ Increasing the setting will shorten the notch depth and the phase lag. 							
Pn213	Vibration Filter Selection						Position
Setting range	0 to 3	Unit	–	Default setting	0	Power OFF and ON	–

8-3 Vibration Suppression Parameters

Explanation of Set Values

Set value	Explanation
0	Vibration filter 1 and 2 enabled
1	With external input (DFSEL1), either 1 and 3 or 2 and 4 can be selected. · Open: Vibration filters 1 and 3 enabled · Shorted: Vibration filters 2 and 4 enabled
2	With external input (DFSEL1 and DFSEL2), one of the filters 1 to 4 can be selected. · When DFSEL1 and DFSEL2 are both open: Vibration filter 1 enabled · When DFSEL1 is shorted and DFSEL2 is open: Vibration filter 2 enabled · When DFSEL1 is open and DFSEL2 is shorted: Vibration filter 3 enabled · When DFSEL1 and DFSEL2 are both shorted: Vibration filter 4 enabled
3	It is switched with position command direction. · Forward direction: Vibration filters 1 and 3 enabled · Reverse direction: Vibration filters 2 and 4 enabled

Pn214	Vibration Frequency 1 Position						
Setting range	0 to 2,000	Unit	0.1 Hz	Default setting	0	Power OFF and ON	-

- ♦ Set vibration frequency 1 to suppress vibration at the end of the load in anti-vibration control.
- ♦ Measure the frequency of vibration at the end of the load and make the setting in units of 0.1 Hz.
- ♦ Setting frequency is 1.0 to 200.0 Hz. The function will be disabled if the setting is 0 to 0.9 Hz.
- ♦ Refer to "Anti-vibration Control" (P.6-3) for more information on settings.

Pn215	Vibration Filter 1 Setting Position						
Setting range	0 to 1,000	Unit	0.1 Hz	Default setting	0	Power OFF and ON	-

- ♦ First set the Vibration Frequency 1 (Pn214). Then reduce the setting if force saturation occurs or increase the setting to increase operation speed. Normally, use a setting of 0.
- ♦ Set value is restricted in the following manner.
 Upper limit: Corresponding vibration frequency
 Lower limit: Vibration frequency + vibration filter setting ≥ 100
- ♦ Refer to "Anti-vibration Control" (P.6-3) for more information on settings.

Pn216	Vibration Frequency 2 Position						
Setting range	0 to 2,000	Unit	0.1 Hz	Default setting	0	Power OFF and ON	-

- ♦ Set vibration frequency 2 to suppress vibration at the end of the load in damping control.
- ♦ Measure the frequency of vibration at the end of the load and make the setting in units of 0.1 Hz.
- ♦ Setting frequency is 1.0 to 200.0 Hz. The function will be disabled if the setting is 0 to 0.9 Hz.
- ♦ Refer to "Anti-vibration Control" (P.6-3) for more information on settings.

Pn217	Vibration Filter 2 Setting Position						
Setting range	0 to 1,000	Unit	0.1 Hz	Default setting	0	Power OFF and ON	-

- ♦ First set the Vibration Frequency 2 (Pn216). Then reduce the setting if force saturation occurs or increase the setting to increase operation speed. Normally, use a setting of 0.
- ♦ Set value is restricted in the following manner.
 Upper limit: Corresponding vibration frequency
 Lower limit: Vibration frequency + vibration filter setting ≥ 100
- ♦ Refer to "Anti-vibration Control" (P.6-3) for more information on settings.

8-3 Vibration Suppression Parameters

Pn218	Vibration Frequency 3							Position
Setting range	0 to 2,000	Unit	0.1 Hz	Default setting	0	Power OFF and ON	–	
<ul style="list-style-type: none"> ♦ Set vibration frequency 3 to suppress vibration at the end of the load in damping control. ♦ Measure the frequency of vibration at the end of the load and make the setting in units of 0.1 Hz. ♦ Setting frequency is 1.0 to 200.0 Hz. The function will be disabled if the setting is 0 to 0.9 Hz. ♦ Refer to "Anti-vibration Control" (P.6-3) for more information on settings. 								
Pn219	Vibration Filter 3 Setting							Position
Setting range	0 to 1,000	Unit	0.1 Hz	Default setting	0	Power OFF and ON	–	
<ul style="list-style-type: none"> ♦ First set the Vibration Frequency 3 (Pn218). Then reduce the setting if force saturation occurs or increase the setting to increase operation speed. Normally, use a setting of 0. ♦ Set value is restricted in the following manner. Upper limit: Corresponding vibration frequency Lower limit: Vibration frequency + vibration filter setting ≥ 100 ♦ Refer to "Anti-vibration Control" (P.6-3) for more information on settings. 								
Pn220	Vibration Frequency 4							Position
Setting range	0 to 2,000	Unit	0.1 Hz	Default setting	0	Power OFF and ON	–	
<ul style="list-style-type: none"> ♦ Set vibration frequency 4 to suppress vibration at the end of the load in damping control. ♦ Measure the frequency of vibration at the end of the load and make the setting in units of 0.1 Hz. ♦ Setting frequency is 1.0 to 200.0 Hz. The function will be disabled if the setting is 0 to 0.9 Hz. ♦ Refer to "Anti-vibration Control" (P.6-3) for more information on settings. 								
Pn221	Vibration Filter 4 Setting							Position
Setting range	0 to 1,000	Unit	0.1 Hz	Default setting	0	Power OFF and ON	–	
<ul style="list-style-type: none"> ♦ First set the Vibration Frequency 4 (Pn220). Then reduce the setting if force saturation occurs or increase the setting to increase operation speed. Normally, use a setting of 0. ♦ Set value is restricted in the following manner. Upper limit: Corresponding vibration frequency Lower limit: Vibration frequency + vibration filter setting ≥ 100 ♦ Refer to "Anti-vibration Control" (P.6-3) for more information on settings. 								
Pn222	Position Command Filter Time Constant							Position
Setting range	0 to 10,000	Unit	0.1 ms	Default setting	0	Power OFF and ON	–	
<ul style="list-style-type: none"> ♦ The position command filter time constant is the first-order lag filter inserted after the electronic ratio for the command pulse input. ♦ The position command filter time constant can be used for the following: <ul style="list-style-type: none"> · If the command pulses change abruptly, the filter can be used to reduce the stepping movement of the motor. · The following are examples of when the command pulses can change abruptly: The electronic ratio setting is high (10 times or higher). The command pulse frequency is low. 								

8-3 Vibration Suppression Parameters

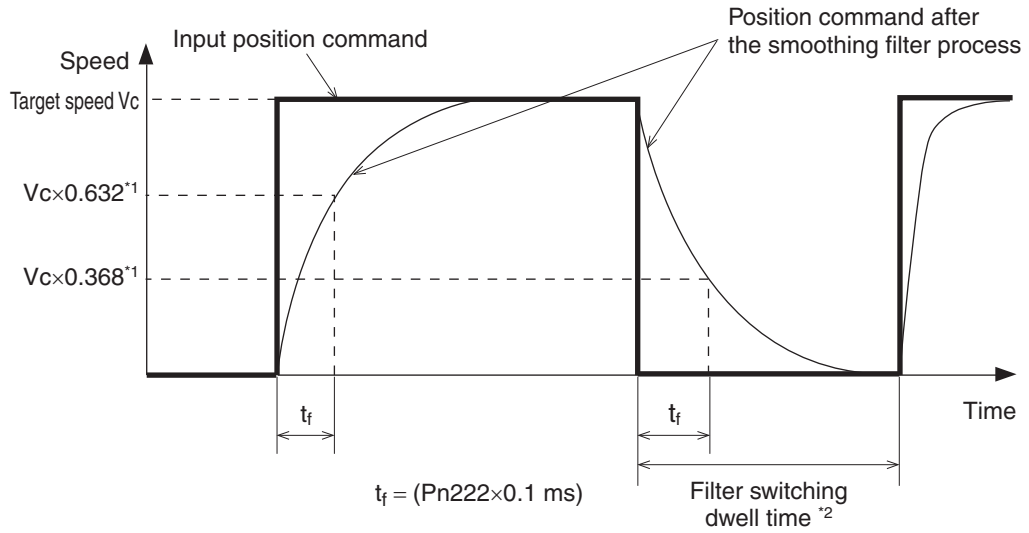

*1 The actual process is subject to calculation error.

*2 If accumulated pulses remain within the filter after the filter set value has been changed, etc., the motor may operate at a speed higher than the command speed immediately after switching the filter.

Pn223	Smoothing Filter Time Constant						Position
Setting range	0 to 10,000	Unit	0.1 ms	Default setting	0	Power OFF and ON	-

- ♦ Set the FIR filter time constant used for command pulse input. (FIR: Finite impulse response)
- ♦ The higher the set value, the smoother the command pulses.

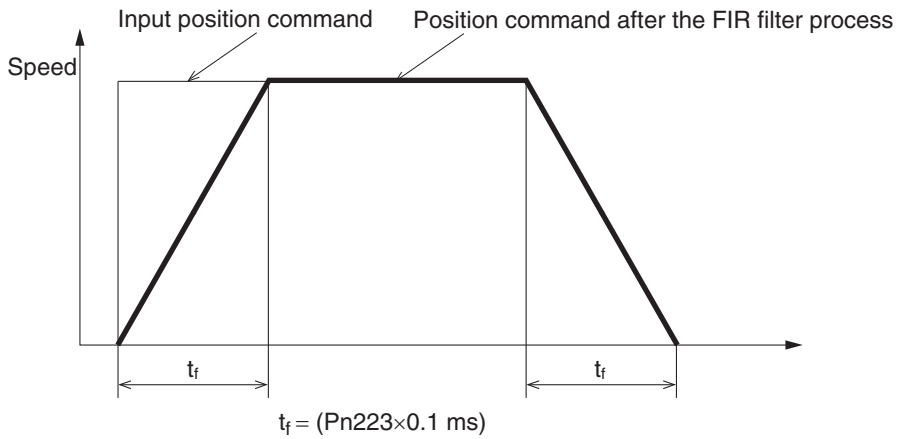

8-4 Analog Control Parameters

Pn300	Command Speed Selection						Speed
Setting range	0 to 3	Unit	–	Default setting	0	Power OFF and ON	–

Explanation of Set Values

Set value	Explanation
0	Analog speed command
1	No. 1 Internally Set Speed to No. 4 Internally Set Speed (Pn304 to Pn307)
2	No. 1 Internally Set Speed to No. 3 Internally Set Speed (Pn304 to Pn306), analog speed command
3	No. 1 Internally Set Speed to No. 8 Internally Set Speed (Pn304 to Pn311)

- ♦ Select the speed command when using speed control. The drive has internally set speed function that can be used to easily achieve speed control by using contact inputs.
- ♦ For details on internally set speed function, refer to "Internally Set Speed Control" (P.5-19).

Pn301	Speed Command Direction Selection						Speed
Setting range	0 to 1	Unit	–	Default setting	0	Power OFF and ON	–

Explanation of Set Values

Set value	Explanation
0	Method for designating the direction for the speed command: By analogue command polarity
1	Method for designating the direction for the speed command: By digital input VSIGN

- ♦ Set to reverse the polarity of the speed command input (REF: CN1 pin 14). This is used to change the motor direction without changing the polarity of host device command signals.
- ♦ The default setting for this parameter is 0.
- ♦ The operation of the Linear Servomotor may be abnormal if the polarity of the speed command signal from the Position Control Unit does not agree with the setting of this parameter when the Linear Servo Drive system is comprised of the combination of the Linear Servo Drive set to the SPEED CONTROL mode and an external Position Control Unit.

Command Speed Selection (Pn300)	Speed Command Direction Selection (Pn301)	Analog Speed Command Direction Switching (Pn303)	Analog speed command (REF)	Speed command sign selection (VSIGN)	Motor direction	Conversion graph
0	0	0	+Voltage (0 to 10 V)	Not affected	Forward direction	Refer to Figure A
			-Voltage (-10 to 0 V)	Not affected	Reverse direction	
		1	+Voltage (0 to 10 V)	Not affected	Reverse direction	Refer to Figure B
			-Voltage (-10 to 0 V)	Not affected	Forward direction	
	1	Not affected	+Voltage (0 to 10 V)	OFF	Forward direction	Refer to Figure C
				-Voltage (-10 to 0 V)	ON	
			+Voltage (0 to 10 V)	OFF	Forward direction	
				-Voltage (-10 to 0 V)	ON	

8-4 Analog Control Parameters

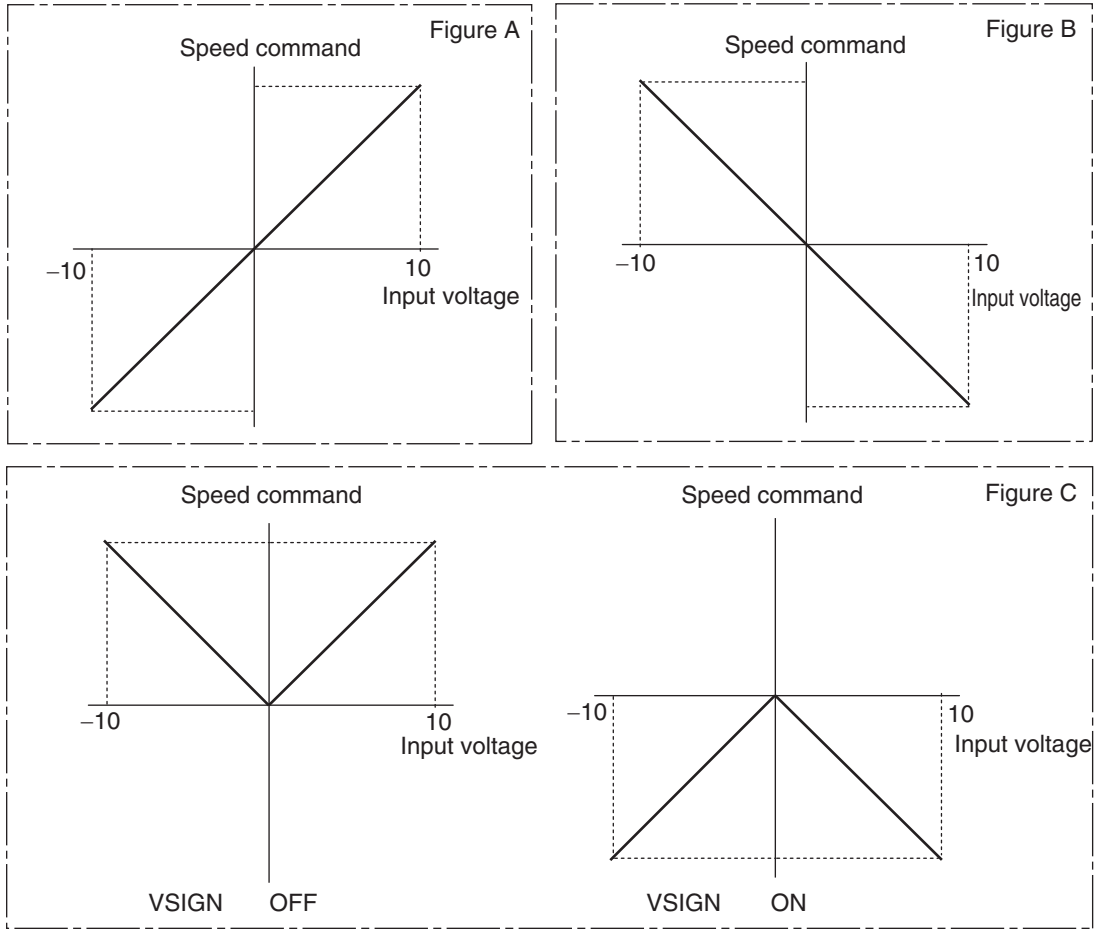

Pn302	Speed Command Scale						<input type="checkbox"/> Speed	<input type="checkbox"/> Force
Setting range	0 to 2,000	Unit	(mm/s)/V	Default setting	100	Power OFF and ON	-	
<ul style="list-style-type: none"> ♦ Set the relation between the voltage applied to the speed command input (REF: CN1 pin 14) and the motor speed. ♦ For details on speed control, refer to "Speed Control" (P.5-8). 								
Pn303	Analog Speed Command Direction Switching						<input type="checkbox"/> Speed	
Setting range	0 to 1	Unit	-	Default setting	1	Power OFF and ON	-	

Explanation of Set Values

Set value	Explanation
0	Direction is changed by analog speed command (REF) voltage. +Voltage: Forward direction -Voltage: Reverse direction
1	Direction is changed by analog speed command voltage. +Voltage: Reverse direction -Voltage: Forward direction

Pn304	No. 1 Internally Set Speed						<input type="checkbox"/> Speed	
Setting range	-20,000 to 20,000	Unit	mm/s	Default setting	0	Power OFF and ON	-	

Pn305	No. 2 Internally Set Speed						Speed
Setting range	-20,000 to 20,000	Unit	mm/s	Default setting	0	Power OFF and ON	-

Pn306	No. 3 Internally Set Speed						Speed
Setting range	-20,000 to 20,000	Unit	mm/s	Default setting	0	Power OFF and ON	-

Pn307	No. 4 Internally Set Speed						Speed
Setting range	-20,000 to 20,000	Unit	mm/s	Default setting	0	Power OFF and ON	-

♦ This is also the speed limit in force control. The Force Command/Speed Limit Selection (Pn317) can be used to switch to an external analog limit.

Pn308	No. 5 Internally Set Speed						Speed
Setting range	-20,000 to 20,000	Unit	mm/s	Default setting	0	Power OFF and ON	-

Pn309	No. 6 Internally Set Speed						Speed
Setting range	-20,000 to 20,000	Unit	mm/s	Default setting	0	Power OFF and ON	-

Pn310	No. 7 Internally Set Speed						Speed
Setting range	-20,000 to 20,000	Unit	mm/s	Default setting	0	Power OFF and ON	-

Pn311	No. 8 Internally Set Speed						Speed
Setting range	-20,000 to 20,000	Unit	mm/s	Default setting	0	Power OFF and ON	-

♦ If internal speed settings are enabled in the Command Speed Selection (Pn300), set the No. 1 to 4 internally set speed in Pn304 to Pn307 and the No. 5 to 8 internally set speed in Pn308 to Pn311. Set the speed in mm/s.

♦ The polarity of the set values indicates the polarity of the internally set speed.

+	The forward direction towards the cable output side.
-	The reverse direction contrary to the cable output side.

♦ The absolute value of the parameter setting is limited by the Overspeed Level Setting (Pn910).

Pn312	Soft Start Acceleration Time						Speed
Setting range	0 to 10,000	Unit	ms/(1,000 mm/s)	Default setting	0	Power OFF and ON	-

8-4 Analog Control Parameters

Pn313	Soft Start Deceleration Time						Speed
Setting range	0 to 10,000	Unit	ms/(1,000 mm/s)	Default setting	0	Power OFF and ON	-

- ♦ Control the speed by setting acceleration/deceleration to the speed command inside the drive.
- ♦ A soft start can be set when inputting speed commands of stepping movement or when using internal speed setting.
- ♦ Do not set acceleration/deceleration time settings when using the drive in combination with an external position loop. (Set both Pn312 and Pn313 to 0.)

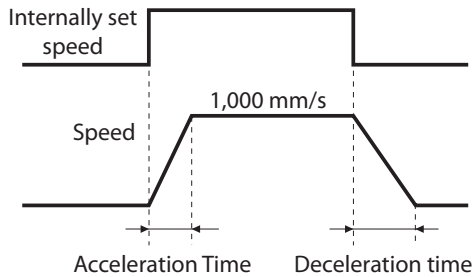

Pn314	S-curve Acceleration/Deceleration Time Setting						Speed
Setting range	0 to 1,000	Unit	ms	Default setting	0	Power OFF and ON	-

- ♦ Set the pseudo-S-curve acceleration/deceleration value to add to the speed command to enable smooth operation. This is useful for applications where impact may occur due to a large change in acceleration or deceleration when starting or stopping with linear acceleration or deceleration.

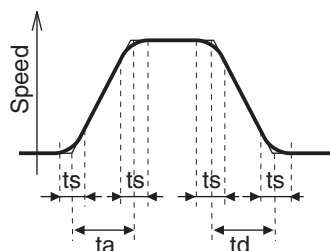

1. Basic linear acceleration time and deceleration time are set by Pn312 and Pn313, respectively.
2. The S-curve time is set by Pn314 (unit: 2 ms) based on the time width around the point of inflection during linear acceleration and deceleration.

ta: Pn312 Use $\frac{ta}{2} > ts$, and $\frac{td}{2} > ts$
 td: Pn313
 ts: Pn314 as settings.

Pn315	Zero Speed Designation Selection						Speed Force
Setting range	0 to 3	Unit	-	Default setting	0	Power OFF and ON	-

Explanation of Set Values

Set value	Explanation
0	Zero speed designation function is disabled.
1	Speed command becomes 0 upon zero speed designation input. (Refer to Figure A)
2	Speed command becomes 0 upon zero speed designation input, and servo locks with position control when actual speed reaches below Zero Speed Designation Level (Pn316). (Refer to Figure B)
3	Servo locks with position control upon zero speed designation input and when speed command reaches below Zero Destination Level (Pn316). (Refer to Figure C)

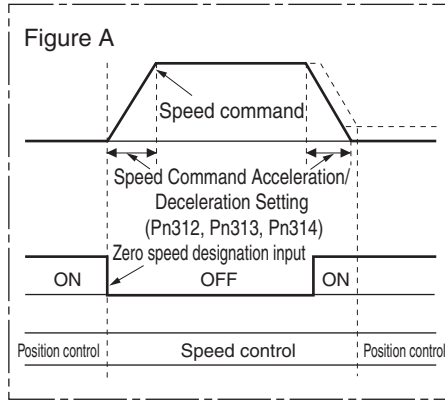

- When the zero speed designation input is turned ON, the speed command is forcibly set to 0.
- Set the acceleration/deceleration setting of the speed command using Soft Start Acceleration Time (Pn312), Soft Start Deceleration Time (Pn313) or S-curve Acceleration/Deceleration Time Setting (Pn314).

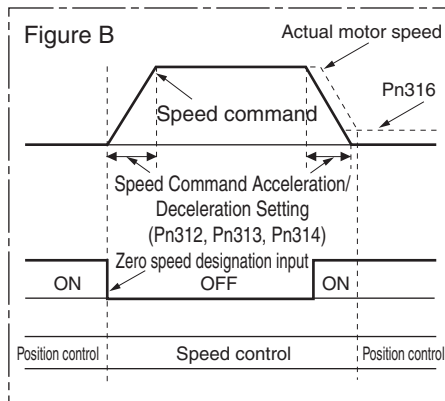

- When the zero speed designation input is turned ON, the speed command is forcibly set to 0. When the actual motor speed is less than the Position Lock Level Setting (Pn316), the operation switches to position control and servo locks. In addition, when the zero speed designation input is turned OFF, the operation switches to speed control.
- Since the position command for position control is forced to be 0, properly set the position loop gain, various error detection functions and other settings.
- Use this parameter when the CONTROL mode Selection (Pn001) is set to 1 (speed control). This may not operate correctly if the CONTROL mode Setting (Pn001) is set to 3 (position or speed control) or 4 (position or force control).

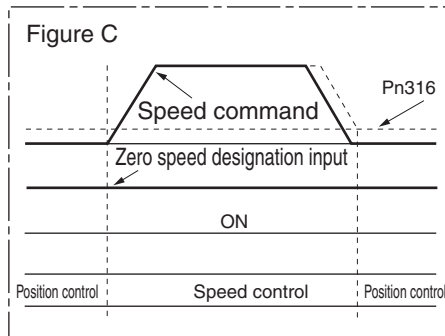

- When the zero speed designation input is turned ON and the speed command is less than the Position Lock Level Setting (Pn316), the operation switches to position control and servo locks.
- When the zero speed designation input is turned ON, the speed command will never be 0. You need to change the speed command.
- Since the operation is executed as a normal position control during position control, properly set the position loop gain, various error detection functions and other settings.
- Use this parameter when the CONTROL mode Selection (Pn001) is set to 1 (speed control). This may not operate correctly if the CONTROL mode Setting (Pn001) is set to 3 (position or speed control) or 4 (position or force control).

8-4 Analog Control Parameters

Pn316	Position Lock Level Setting						Speed	Force
Setting range	10 to 20,000	Unit	mm/s	Default setting	30	Power OFF and ON	–	

- ◆ Servo locks with position control when the speed of the motor is lower than the setting of this parameter.
- ◆ The setting of this parameter is valid for both forward and reverse direction regardless of the motor moving direction.

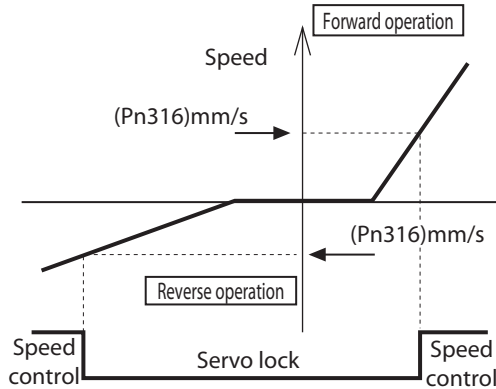

Pn317	Force Command/Speed Limit Selection						Force
Setting range	0 to 2	Unit	–	Default setting	0	Power OFF and ON	–

Explanation of Set Values

Set value	Force command	Speed limit
0	Analog input 1 (FREF1)	Pn321
1	Analog input 2 (FREF2)	Analog input 1 (FREF1)
2	Analog input 1 (FREF1)	Pn321, Pn322

- ◆ It depends on the CONTROL mode.
- ◆ When the CONTROL mode is set to speed control/force control, the force command input is set to analog input 2.

Pn318	Force Command Direction Selection						Force
Setting range	0 to 1	Unit	–	Default setting	0	Power OFF and ON	–

Explanation of Set Values

Set value	Explanation
0	Method for designating the direction for the force command: By analogue force command polarity
1	Method for designating the direction for the force command: By digital input FSIGN

- ◆ The default setting for this parameter is 0.

Force Command /Speed Limit Selection (Pn317)	Force Command Direction Selection (Pn318)	Analog Force Command Direction Switching (Pn320)	Analog force command (FREF)	Force command sign selection (FSIGN)	Motor direction	Conversion graph	
0	0	0	+Voltage (0 to 10 V)	Not affected	Forward direction	Refer to Figure A	
			-Voltage (-10 to 0 V)	Not affected	Reverse direction		
		1	+Voltage (0 to 10 V)	Not affected	Reverse direction	Refer to Figure B	
			-Voltage (-10 to 0 V)	Not affected	Forward direction		
	1	Not affected	-	+Voltage (0 to 10 V)	OFF	Forward direction	Refer to Figure C
				-Voltage (-10 to 0 V)			
			+	+Voltage (0 to 10 V)	ON	Reverse direction	
				-Voltage (-10 to 0 V)			

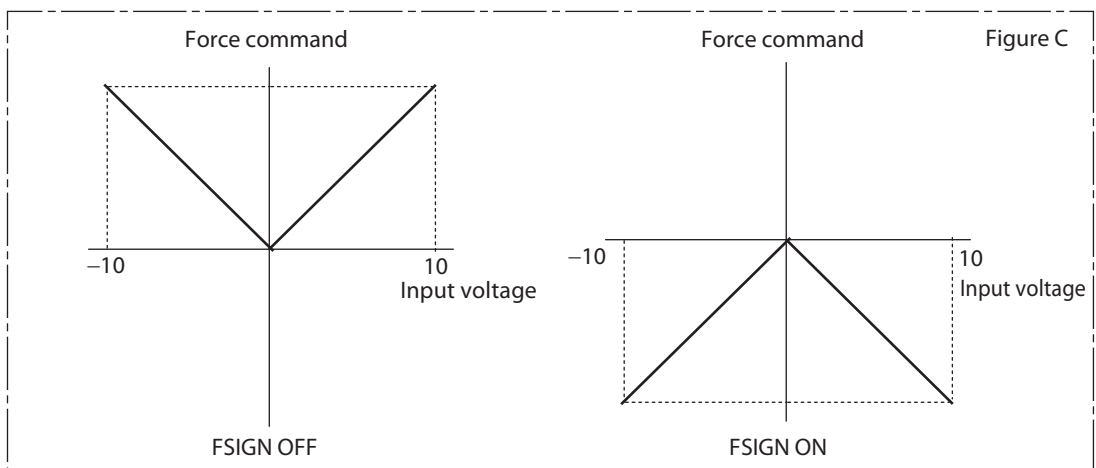
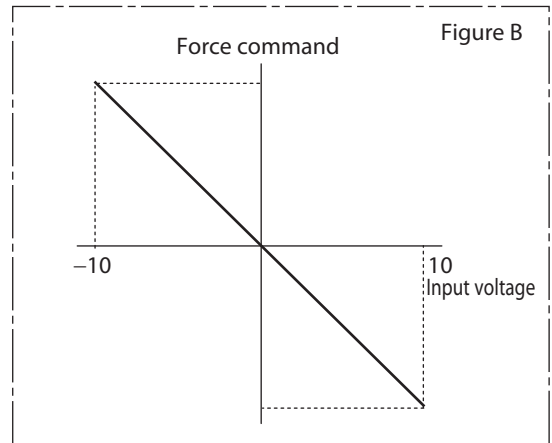
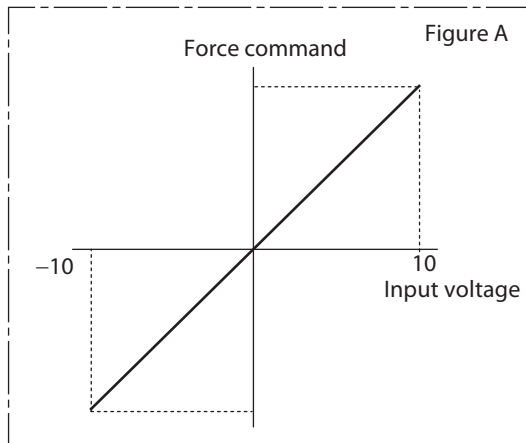

8-4 Analog Control Parameters

Pn319	Force Command Scale							Force
Setting range	10 to 100	Unit	0.1 V/100%	Default setting	30	Power OFF and ON	–	

- ♦ Set the relation between the voltage applied to the speed limit input (VLIM: CN1 pin 14) and the motor speed.
- ♦ Refer to "Force Control" (P.5-14) for more information on force command scale.

Pn320	Analog Force Command Direction Switching							Force
Setting range	0 to 1	Unit	–	Default setting	0	Power OFF and ON	–	

Explanation of Set Values

Set value	Explanation
0	Direction of motor force: The +command indicates the forward direction.
1	Direction of motor force: The +command indicates the reverse direction.

- ♦ Reverse the polarity of the force command input (REF/FREF1: CN1 pin 14 or PCL/FREF2: CN1 pin 16).

Pn321	Speed Limit Value Setting							Force
Setting range	0 to 20,000	Unit	mm/s	Default setting	0	Power OFF and ON	–	

Pn322	Reverse Direction Speed Limit Value Setting							Force
Setting range	0 to 20,000	Unit	mm/s	Default setting	0	Power OFF and ON	–	

- ♦ Corresponding speed limit values during force control is shown in the table below.

Force Command/Speed Limit Selection (Pn327)	Speed Limit Value Setting (Pn321)	Reverse Direction Speed Limit Value Setting (Pn322)	Zero Speed Designation Selection (Pn315)	Zero speed clamp	Analog force command direction	Speed limit value
0	0 to 20,000	Not affected	0	Not affected	Not affected	Pn321 set value
			1 to 3	OFF		Pn321 set value
				ON		0
1	0 to 20,000	0 to 20,000	0	Not affected	Forward direction	Pn321 set value
					Reverse direction	Pn322 set value
	0 to 20,000	1 to 20,000	1 to 3	OFF	Forward direction	Pn321 set value
					Reverse direction	Pn322 set value
0 to 20,000	1 to 20,000	1 to 3	ON	Not affected	0	

Pn323	Encoder Type Selection						All
Setting range	0 to 2	Unit	-	Default setting	0	Power OFF and ON	Yes

Explanation of Set Values

Set value	Explanation
0	Line drive A/B pulse type* 1
1	SinCos via Serial Converter* 2 or Serial Incremental Encoder (Sony)* 3
2	Serial Absolute Encoder (Sony, Mitutoyo)* 4

- *1. The drive internal process count direction relative to the external scale of phase-AB output type is explained below.
- *2. The SinCos Encoder is connected to the Serial Converter and the Serial Converter transmit the signal to the drive via serial link. Optionally, you can also connect to the Serial Converter the Hall sensor signals and Temperature sensors.
- *3. The available scales are SR75, SR85 and SL700/PL101-RP.
- *4. The available scales are:
 Sony: SR77 and SR78.
 Mitutoyo: AT573, ST771A and ST773A.

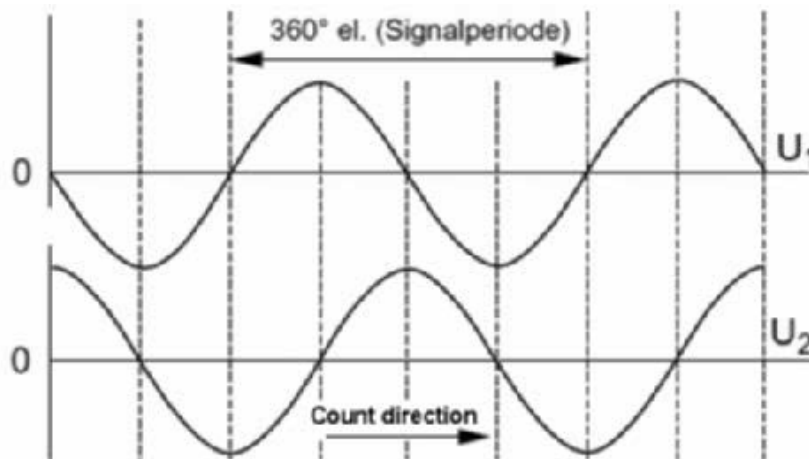
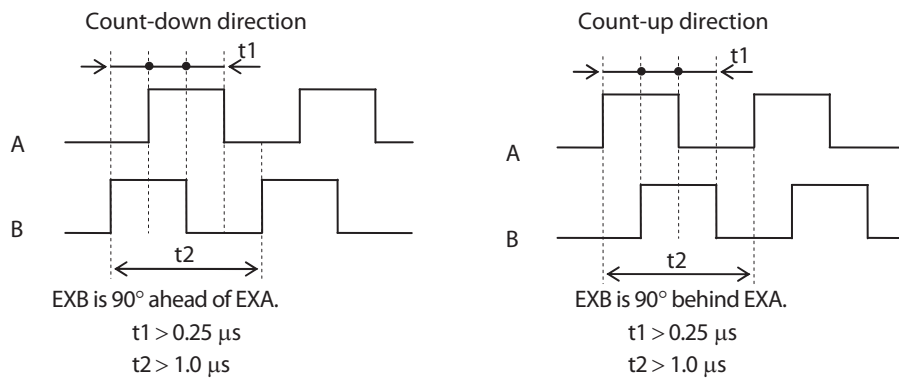

- ♦ For the external scale connection direction, set the direction so that count-up occurs when the motor moves in the direction of the cable output and count-down when the motor moves in the direction opposite to the cable output. If the connection direction cannot be selected due to installation conditions, the count direction can be reversed using encoder pulse direction switching (Pn326).
- ♦ Take note that if Pn000 = 1, the scale count direction becomes opposite to the count direction used for monitoring the total external scale feedback pulses, etc.
 If Pn000 = 0, the count direction matches the count direction for monitoring.
- ♦ Even when the drive speed is within the specified range, an acceleration error will occur if the motor shaft movement speed exceeds the maximum speed.

8-4 Analog Control Parameters

Pn326	Encoder Direction Switching						<input type="checkbox"/> All
Setting range	0 to 1	Unit	–	Default setting	0	Power OFF and ON	Yes

Explanation of Set Values

Set value	Explanation
0	Encoder count direction non-reversed
1	Encoder count direction reversed

Pn327	Encoder Phase-Z Setting						<input type="checkbox"/> All
Setting range	0 to 1	Unit	–	Default setting	0	Power OFF and ON	Yes

Explanation of Set Values

Set value	Explanation
0	Phase-Z disconnection detection enabled
1	Phase-Z disconnection detection disabled

8-5 Interface Monitor Setting Parameters

Pn400	Input Signal Selection 1						<input type="button" value="All"/>
Setting range	0 to 00FFFFFFh	Unit	–	Default setting	00828282h (8553090)	Power OFF and ON	Yes
*Default is NOT in all models							
Pn401	Input Signal Selection 2						<input type="button" value="All"/>
Setting range	0 to 00FFFFFFh	Unit	–	Default setting	00818181h (8487297)	Power OFF and ON	Yes
*Default is POT in all models							
Pn402	Input Signal Selection 3						<input type="button" value="All"/>
Setting range	0 to 00FFFFFFh	Unit	–	Default setting	0091910Ah (9539850)	Power OFF and ON	Yes
*Default is DFSEL1 for position control and ZEROSPD in speed and force control							
Pn403	Input Signal Selection 4						<input type="button" value="All"/>
Setting range	0 to 00FFFFFFh	Unit	–	Default setting	0060606h (394758)	Power OFF and ON	Yes
*Default is GSEL in all models							
Pn404	Input Signal Selection 5						<input type="button" value="All"/>
Setting range	0 to 00FFFFFFh	Unit	–	Default setting	0000100Ch (4108)	Power OFF and ON	Yes
*Default is GSEL1 in position control and VSEL3 in speed control							
Pn405	Input Signal Selection 6						<input type="button" value="All"/>
Setting range	0 to 00FFFFFFh	Unit	–	Default setting	00030303h (197379)	Power OFF and ON	Yes
*Default is RUN in all models							
Pn406	Input Signal Selection 7						<input type="button" value="All"/>
Setting range	0 to 00FFFFFFh	Unit	–	Default setting	00000F07h (3847)	Power OFF and ON	Yes
*Default is ECRST in position control and VSEL2 in speed control							
Pn407	Input Signal Selection 8						<input type="button" value="All"/>
Setting range	0 to 00FFFFFFh	Unit	–	Default setting	00040404h (263172)	Power OFF and ON	Yes
*Default is RESET in all models							
Pn408	Input Signal Selection 9						<input type="button" value="All"/>
Setting range	0 to 00FFFFFFh	Unit	–	Default setting	00050505h (328965)	Power OFF and ON	Yes
*Default is TVSEL in all models							
Pn409	Input Signal Selection 10						<input type="button" value="All"/>
Setting range	0 to 00FFFFFFh	Unit	–	Default setting	00000E88h (3720)	Power OFF and ON	Yes
*Default is IPG in position control and VSEL1 in speed control							
Pn410	Output Signal Selection 1						<input type="button" value="All"/>
Setting range	0 to 00FFFFFFh	Unit	–	Default setting	00030303h (197379)	Power OFF and ON	Yes
*Default is BKIR in all models							
Pn411	Output Signal Selection 2						<input type="button" value="All"/>
Setting range	0 to 00FFFFFFh	Unit	–	Default setting	00020202h (131586)	Power OFF and ON	Yes
*Default is READY in all models							
Pn412	Output Signal Selection 3						<input type="button" value="All"/>
Setting range	Fixed value	Unit	–	Default setting	00010101h (65793)	Power OFF and ON	Yes
*Default is ALM in all models. Fix setting, do not change							
Pn413	Output Signal Selection 4						<input type="button" value="All"/>
Setting range	0 to 00FFFFFFh	Unit	–	Default setting	00050505h (328964)	Power OFF and ON	Yes

*Default is TGON in all models

•Refer to "Sequence I/O Signal" (P.6-35) for more information on settings.

8-5 Interface Monitor Setting Parameters

Pn414	Output Signal Selection 5						<input type="button" value="All"/>
Setting range	0 to 00FFFFFFh	Unit	–	Default setting	00070707h (460551)	Power OFF and ON	Yes

*Default is ZSP in all models

Pn415	Output Signal Selection 6						<input type="button" value="All"/>
Setting range	0 to 00FFFFFFh	Unit	–	Default setting	00060606h (394758)	Power OFF and ON	Yes

*Default is FLC in all models

Pn416	Analog Monitor 1 Selection						<input type="button" value="All"/>
Setting range	0 to 22	Unit	–	Default setting	0	Power OFF and ON	-

Explanation of Set Values

Set value	Explanation		
	Monitor type	Unit	Output gain when Pn417 = 0
0	Motor speed	mm/s	500
1	Position command speed * 2	mm/s	500
2	Internal position command speed * 2	mm/s	500
3	Speed control command	mm/s	500
4	Force command	%	33
5	Command position error * 3	pulse (command units)	3,000
6	Encoder position error * 3	pulse (encoder units)	3,000
7	Reserved	-	-
8	Reserved	-	-
9	DC-Bus voltage	V	80
10	Regeneration load ratio	%	33
11	Overload load ratio	%	33
12	Forward direction force limit	%	33
13	Reverse direction force limit	%	33
14	Speed limit value	mm/s	500
15	Mass ratio	%	500
16	Analog input 1 * 1	V	1
17	Analog input 2 * 1	V	1
18	Analog input 3 * 1	V	1
19	Reserved	–	–
20	Drive temperature	°C	10
21	Reserved	-	-
22	Reserved	-	-

*1. Analog inputs 1 to 3 will output terminal voltage even when terminal is not used.

*2. Corresponding to command pulse input, command pulse speed is before command filter (position command filter time constant and smoothing filter time constant), and internal command speed is after command filter.

*3. The position command error is an error from the command pulse input, while the encoder position error is the error at the input of the position loop.

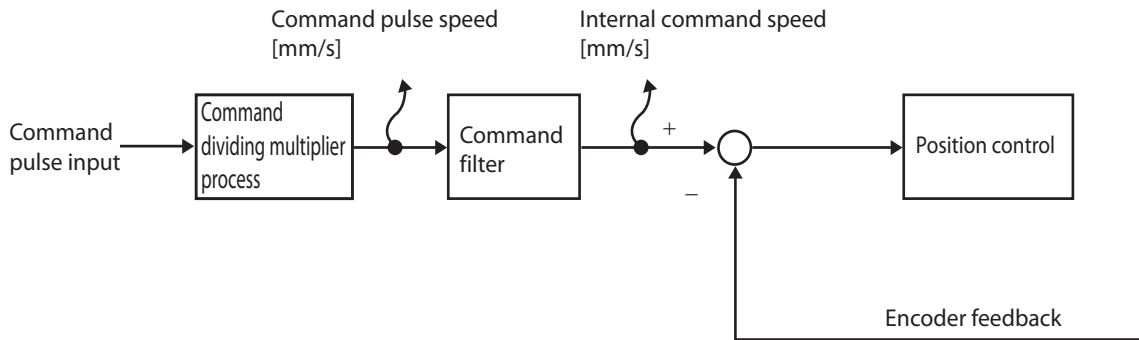

*3. Position error and feedback pulse error come in 2 types, encoder unit and command unit. Encoder unit will be an error of position control input section and command unit will be an error of command pulse input.

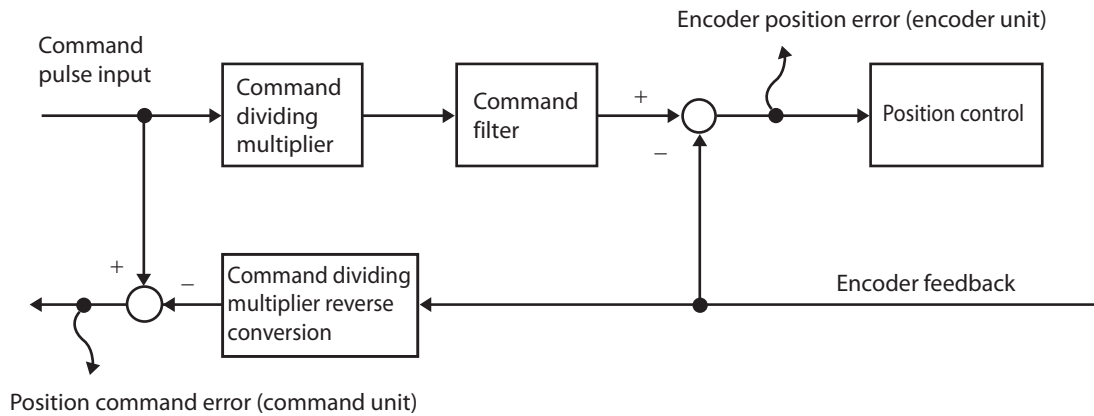

Pn417	Analog Monitor 1 Scale Setting						All
Setting range	0 to 214,748,364	Unit	Pn416 monitor unit/V	Default setting	0	Power OFF and ON	-
♦ Set output gain for analog monitor 1.							
Pn418	Analog Monitor 2 Selection						All
Setting range	0 to 22	Unit	-	Default setting	4	Power OFF and ON	-
♦ Select the type of analog monitor 2. ♦ The set value for this parameter is same as Analog Monitor 1 Type (Pn416).							
Pn419	Analog Monitor 2 Scale Setting						All
Setting range	0 to 214,748,364	Unit	Pn418 monitor unit/V	Default setting	0	Power OFF and ON	-
♦ Set output gain for analog monitor 2.							
Pn420	Reserved						All
Setting range	-	Unit	-	Default setting	-	Power OFF and ON	-

8-5 Interface Monitor Setting Parameters

Pn421	Analog Monitor Output Selection						All
Setting range	0 to 2	Unit	–	Default setting	0	Power OFF and ON	–

♦ Select the analog monitor output voltage direction.

Set value	Output range	Data output
0	-10 to 10 V	
1	0 to 10 V	
2	0 to 10 V	

♦ When monitor type is motor speed and gain of conversion is 500 (1 V = 500 mm/s)

Pn422	Analog Input 1 Offset						All
Setting range	-5,578 to 5,578	Unit	0.359 mV	Default setting	0	Power OFF and ON	–

- ♦ Adjust the offset of the speed command input (REF: CN1 pin 14).
- ♦ The offset amount is approx. the set value times 0.359 mV.
- ♦ There are 2 ways to adjust the offset.
 - Manual adjustment
 - Automatic adjustment
- ♦ The manual adjustment is as follows:
 - To adjust the offset for individual drives, accurately input 0V to the speed command input/force command input (REF/FREF1) (or connect to the signal ground), and then set this parameter so that the motor does not rotate.
 - If you use a position loop in the host device, set this parameter so that there are no accumulated pulses at servo lock stop status.
- ♦ The automatic adjustment is as follows:
 - This parameter will be automatically set when automatic offset adjustment is executed.

8-5 Interface Monitor Setting Parameters

Pn423	Analog Input 1 Filter Time Constant							All
Setting range	0 to 6,400	Unit	0.01 ms	Default setting	0	Power OFF and ON	–	
<ul style="list-style-type: none"> ♦ Set the first-order lag filter time constant in the speed command input (REF: CN1 pin 14). 								
Pn424	Excessive Analog Input 1							All
Setting range	0 to 100	Unit	0.1 V	Default setting	0	Power OFF and ON	–	
<ul style="list-style-type: none"> ♦ Set the overflow level for speed command input (REF: CN1 pin 14) or force command input (FREF1: CN1 pin 14) using voltage after offset compensation. ♦ Excessive analog input (alarm display No. 39) will be disabled if this parameter is set to 0. 								
Pn425	Analog Input 2 Offset							All
Setting range	–342 to 342	Unit	5.86 mV	Default setting	0	Power OFF and ON	–	
<ul style="list-style-type: none"> ♦ Adjust the offset of the speed command input (REF: CN1 pin 14). ♦ The offset amount is approx. the set value times 5.86 mV. ♦ There are 2 ways to adjust the offset. <ul style="list-style-type: none"> · Manual adjustment · Automatic adjustment ♦ The manual adjustment is as follows: <ul style="list-style-type: none"> · To adjust the offset for individual drives, accurately input 0 V to the speed command input/ force command input (REF/FREF1) (or connect to the signal ground), and then set this parameter so that the motor does not rotate. · If you use a position loop in the host device, set this parameter so that there are no accumulated pulses at servo lock stop status. ♦ The automatic adjustment is as follows: <ul style="list-style-type: none"> This parameter will be automatically set when automatic offset adjustment is executed. 								
Pn426	Analog Input 2 Filter Time Constant							All
Setting range	0 to 6,400	Unit	0.01 ms	Default setting	0	Power OFF and ON	–	
<ul style="list-style-type: none"> ♦ Set the first-order lag filter time constant in the speed command input (REF: CN1 pin 14). 								
Pn427	Excessive Analog Input 2							All
Setting range	0 to 100	Unit	0.1 V	Default setting	0	Power OFF and ON	–	
<ul style="list-style-type: none"> ♦ Set the overflow level for speed command input (REF: CN1 pin 14) or force command input (FREF1: CN1 pin 14) using voltage after offset compensation. ♦ Excessive analog input (alarm display No. 39) will be disabled if this parameter is set to 0. 								

8-5 Interface Monitor Setting Parameters

Pn428	Analog Input 3 Offset						All
Setting range	-342 to 342	Unit	5.86 mV	Default setting	0	Power OFF and ON	-

- ♦ Adjust the offset of the speed command input (REF: CN1 pin 14).
- ♦ The offset amount is approx. the set value times 5 mV.
- ♦ There are 2 ways to adjust the offset.
 - Manual adjustment
 - Automatic adjustment
- ♦ The manual adjustment is as follows:
 - To adjust the offset for individual drives, accurately input 0 V to the speed command input/ force command input (REF/FREF1) (or connect to the signal ground), and then set this parameter so that the motor does not rotate.
 - If you use a position loop in the host device, set this parameter so that there are no accumulated pulses at servo lock stop status.
- ♦ The automatic adjustment is as follows:
 - This parameter will be automatically set when automatic offset adjustment is executed.

Pn429	Analog Input 3 Filter Time Constant						All
Setting range	0 to 6,400	Unit	0.01 ms	Default setting	0	Power OFF and ON	-

- ♦ Set the first-order lag filter time constant in the speed command input (REF: CN1 pin 14).

Pn430	Excessive Analog Input 3						All
Setting range	0 to 100	Unit	0.1 V	Default setting	0	Power OFF and ON	-

- ♦ Set the overflow level for speed command input (REF: CN1 pin 14) or force command input (FREF1: CN1 pin 14) using voltage after offset compensation.
- ♦ Excessive analog input (alarm display No. 39) will be disabled if this parameter is set to 0.

Pn431	Positioning Completion Range 1						Position
Setting range	0 to 262,144	Unit	Command unit	Default setting	10	Power OFF and ON	-

- ♦ Use this in combination with the Positioning Completion Condition Selection (Pn432) to set the timing to output the positioning completion output. The positioning completion output (INP) will output when the Linear Servomotor (workpiece) movement stops and the number of the accumulated pulses in the error counter is within the set value of this parameter, after command pulse input is completed.
- ♦ Unit for setting is command unit, but it can be changed to encoder unit with Position Setting Unit Selection (Pn520). However, note that unit for error counter overflow level will be changed as well.
- ♦ If this parameter is set to a very small value, the time required for the INP signal to be output will increase and the chattering may occur during output. The setting of the positioning completion range does not affect the precision of the final positioning.

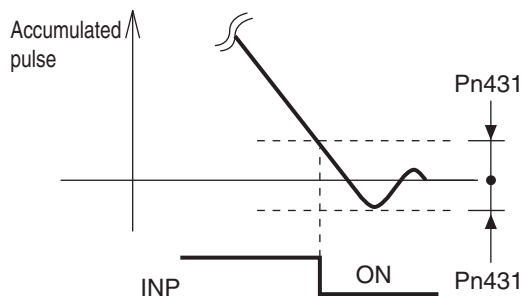

Pn432	Positioning Completion Condition Selection						Position
Setting range	0 to 3	Unit	–	Default setting	0	Power OFF and ON	–

Explanation of Set Values

Set value	Explanation
0	Positioning completion output turns ON when the position error is within the Positioning Completion Range 1 (Pn431).
1	Positioning completion output turns ON when the position error is within the Positioning Completion Range 1 (Pn431) and there is no position command.
2	Positioning completion output turns ON when the zero speed detection signal is ON, the position error is within the Positioning Completion Range 1 (Pn431), and there is no position command.
3	Positioning completion output turns ON when the position error is within the Positioning Completion Range 1 (Pn431) and there is no position command. The ON status will then be held until the Positioning Completion Hold Time (Pn433) elapses. After that, an ON/OFF decision will be made based on the position error at the time.

- ♦ Use this in combination with the Positioning Completion Range 1 (Pn431) to set the operation for positioning completion output (INP: CN1 pin 39).

Pn433	Positioning Completion Hold Time						Position
Setting range	0 to 30,000	Unit	1 ms	Default setting	0	Power OFF and ON	–

- ♦ When Positioning Completion Hold Time (Pn433) is set to 0, hold time becomes infinite and ON status is held until the next position command comes in.

Pn434	Zero Speed Detection						All
Setting range	10 to 20,000	Unit	mm/s	Default setting	50	Power OFF and ON	–

- ♦ General-purpose output timing is set by movement speed mm/s.
- ♦ General-purpose output 1 (ZSP) will be turned ON when the speed of the motor is lower than the setting of this parameter.
- ♦ The setting of this parameter is valid for both forward and reverse direction regardless of the motor direction. This setting has a hysteresis of 10 mm/s.

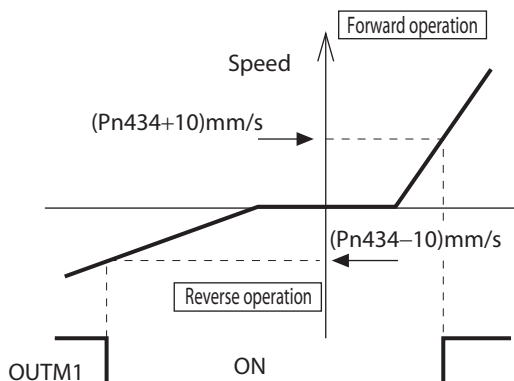

8-5 Interface Monitor Setting Parameters

Pn435	Speed Conformity Detection Width					Speed	
Setting range	10 to 20,000	Unit	mm/s	Default setting	50	Power OFF and ON	-

- ◆ When speed command and motor speed are identical, speed conformity output signal is output.
- ◆ This setting has a hysteresis of 10 mm/s for detection.

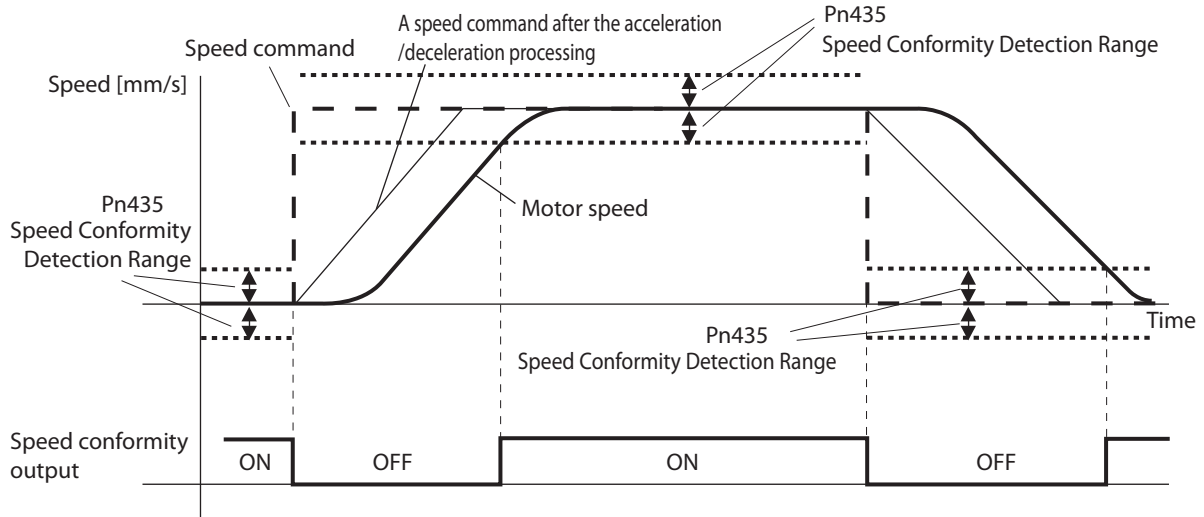

Pn436	Speed for Motor Detection					Speed	
Setting range	10 to 20,000	Unit	mm/s	Default setting	1000	Power OFF and ON	-

- ◆ Speed reached output signal is output when the motor speed reaches the speed set as the achieved speed.
- ◆ This setting has a hysteresis of 10 mm/s for detection.

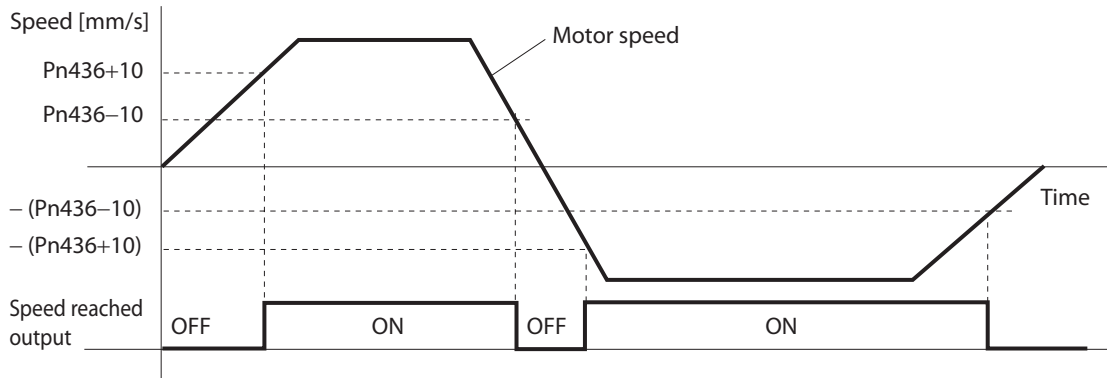

Pn437	Brake Timing when Stopped						All
Setting range	0 to 10,000	Unit	1 ms	Default setting	0	Power OFF and ON	-

- ♦ Set the time required for the Linear Servomotor to be de-energized (servo free) after the brake interlock output (BKIR: CN1pin 10) turns ON (i.e., brake held), when servo OFF status is entered while the Linear Servomotor is stopped.
- ♦ When the Linear Servomotor is stopped and the operation command (RUN) is turned OFF, the brake interlock signal (BKIR) will turn ON, and the servo will turn OFF after waiting for the setting time (set value × ms).

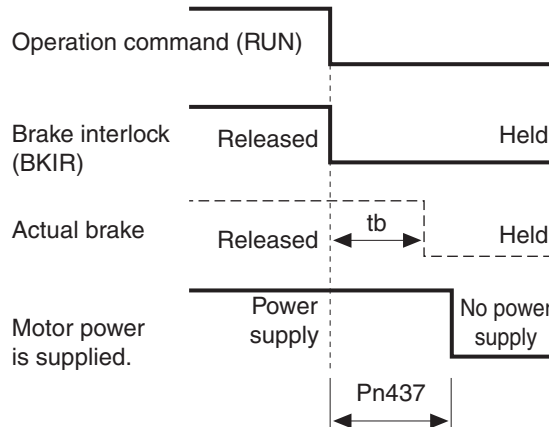

- ♦ Make the setting as follows to prevent the machine (workpiece) from moving or falling due to the delay time in the brake operation (tb).
- ♦ Brake timing when stopped (set value × 1 ms) ≥ tb
- ♦ For details, refer to "Brake Interlock" (P.6-18)

Pn438	Brake Timing during Operation						All
Setting range	0 to 10,000	Unit	1 ms	Default setting	0	Power OFF and ON	-

- ♦ Set the required time for the brake interlock output (BKIR: CN1 pin 10) to turn OFF after the operation command (RUN: CN1 pin 29) is detected to be OFF, when servo OFF status is entered while the Linear Servomotor is operating. While the motor is operating and the operation command (RUN) is turned OFF, the motor will decelerate to reduce movement speed, and the brake interlock signal (BKIR) will turn ON after the setting time (set value × 1 ms) has elapsed.

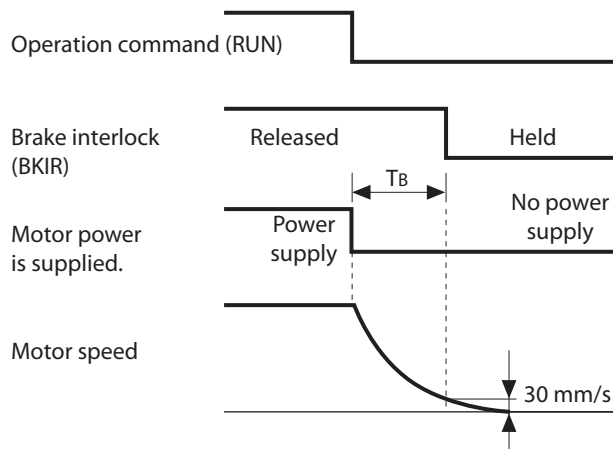

- ♦ TB in the above figure is the brake timing during operation (set value × 1 ms) or the time until the motor speed falls to 30 mm/s or lower, whichever is shorter.
- ♦ For details, refer to "Brake Interlock" (P.6-18).

8-5 Interface Monitor Setting Parameters

Pn439	Brake Release Speed Setting						All
Setting range	30 to 3,000	Unit	mm/s	Default setting	30	Power OFF and ON	Yes

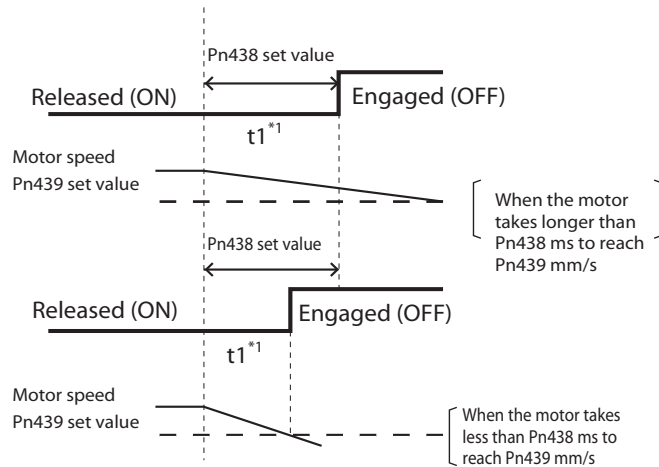

Note: With Linear motor, the brake must be installed separately and is not supplied by OMRON.

Pn440	Warning Output Selection 1						All
Setting range	0 to 10	Unit	–	Default setting	0	Power OFF and ON	–

Explanation of Set Values

Set value	Explanation
0	No
1	Overload warning
2	Excessive regeneration warning
4	Fan warning
5	The Serial Converter detect the Overheat warning
7	Oscillation detection warning
8	Lifetime of capacitor or fan warning
9	Encoder warning
10	Encoder communication error warning

- ♦ Do not set to a value outside the described values.
- ♦ Refer to "Warning List" (P.11-5) for more information on settings.

Pn441	Warning Output Selection 2						All
Setting range	0 to 10	Unit	–	Default setting	0	Power OFF and ON	–

- ♦ The set values for this parameter are same as Warning Output Selection 1 (Pn440).

Pn442	Positioning Completion Range 2						Position
Setting range	0 to 262,144	Unit	Command unit	Default setting	10	Power OFF and ON	–

- ♦ Set the positioning completion range.
- ♦ The set values for this parameter are same as Positioning Completion Range 1 (Pn431).

8-6 Extended Parameters

Pn500	Electronic Ratio Numerator 2						Position
Setting range	1 to 1073741824	Unit	–	Default setting	10000	Power OFF and ON	–
Pn501	Electronic Ratio Numerator 3						Position
Setting range	1 to 1073741824	Unit	–	Default setting	10000	Power OFF and ON	–
Pn502	Electronic Ratio Numerator 4						Position
Setting range	1 to 1073741824	Unit	–	Default setting	10000	Power OFF and ON	–
Pn503	Encoder Dividing Denominator						All
Setting range	1 to 262,144	Unit	–	Default setting	2,500	Power OFF and ON	Yes

- ♦ Division is performed at the rate according to the formula below.

$$\text{Encoder FB pulse} \rightarrow \frac{\text{Pn011}}{\text{Pn503}} \rightarrow \text{Output pulse}$$

- ♦ Therefore, the formula will be as follows when the host side counts pulses through processing with quadruple multiplier.
- ♦ Number of pulse output = $\frac{\text{Pn011}}{\text{Pn503}} \times \text{Encoder pulse}$
- ♦ The pulse output resolution per rotation will never exceed the encoder resolution. (If the above settings are used, the pulse output resolution per rotation will be equal to the encoder resolution.)

Pn504	Drive Prohibition Input Selection						All
Setting range	0 to 2	Unit	–	Default setting	1	Power OFF and ON	Yes

Explanation of Set Values

Set value	Explanation
0	Forward drive prohibition input and reverse drive prohibition input enabled.
1	Forward drive prohibition input and reverse drive prohibition input disabled.
2	Forward drive prohibition input and reverse drive prohibition input enabled.

- ♦ Install limit switches at both ends of the axis to prohibit the motor from travelling in the direction specified by the switch. This can be used to prevent the workpiece from travelling too far and thus prevent damage to the machine.
- ♦ Operation will be as follows if 0 is set.
- ♦ Forward drive prohibition input (POT: CN1 pin 9) and COM connected: Normal status when the forward limit switch does not operate
- ♦ Forward drive prohibition input (POT: CN1 pin 9) and COM open: Forward direction prohibited and reverse direction permitted
- ♦ Reverse drive prohibition input (NOT: CN1 pin 8) and COM connected: Normal status when the reverse limit switch does not operate
- ♦ Reverse drive prohibition input (NOT: CN1 pin 8) and COM open: Reverse direction prohibited and forward direction permitted.

8-6 Extended Parameters

- ♦ If this is set to 0, the Linear Servomotor will decelerate and stop according to the sequence set in the Stop Selection for Drive Prohibition Input (Pn505). For details, refer to explanation for Stop Selection for Drive Prohibition Input (Pn505).
- ♦ If this parameter is set to 0 and the forward and reverse prohibition inputs are both open, an error will be detected in the drive, and a drive prohibition input error (alarm display No. 38) will occur.
- ♦ If this parameter is set to 2, a drive prohibition input error (alarm display No. 38) will occur when the connection between either the forward or reverse prohibition input and COM is open.
- ♦ If a limit switch above the workpiece is turned OFF when using a vertical axis, the upward force will be eliminated, and there may be repeated vertical movement of the workpiece. If this occurs, set the Stop Selection for Drive Prohibition Input (Pn505) to 2 or perform limit using the Host Controller rather than using this function.

Pn505	Stop Selection for Drive Prohibition Input						All
Setting range	0 to 2	Unit	–	Default setting	0	Power OFF and ON	Yes

Explanation of Set Values

Set value	Explanation
0	During deceleration: Dynamic brake operation After stop: Force command is 0 for drive prohibition direction Error counter: Held
1	During deceleration: Force command is 0 for drive prohibition direction After stop: Force command is 0 for drive prohibition direction Error counter: Held
2	During deceleration: Immediate stop After stop: Force command is 0 for drive prohibition direction Error counter: Clear before and after deceleration

- ♦ Set the drive conditions during deceleration or after stopping after the drive prohibition input (POT: CN1 pin 9 or NOT: CN1 pin 8) is enabled.
- ♦ If this is set to 2, the Immediate Stop Force (Pn511) will be used to force limit during deceleration.

Pn506	Stop Selection with Servo OFF						All
Setting range	0 to 9	Unit	–	Default setting	0	Power OFF and ON	–

Explanation of Set Values

Set value	Explanation		
	During deceleration * 3	After stopping	Error counter
0	Dynamic brake operation	Dynamic brake operation	Clear * 4
1	Free-run	Dynamic brake operation	Clear * 4
2	Dynamic brake operation	Servo unlocked	Clear * 4
3	Free-run	Servo unlocked	Clear * 4
4	Dynamic brake operation	Dynamic brake operation	Hold * 2
5	Free-run	Dynamic brake operation	Hold * 2
6	Dynamic brake operation	Servo unlocked	Hold * 2
7	Free-run	Servo unlocked	Hold * 2
8	Immediate stop * 1	Dynamic brake operation	Clear * 4
9	Immediate stop * 1	Servo unlocked	Clear * 4

- ♦ If an error occurs when servo is turned OFF, the operation will be based on the Stop Selection for Alarm Generation (Pn510). Additionally, if the main power supply is turned OFF when servo is OFF, it will be based on the Stop Selection with Main Power Supply OFF (Pn507).
- *1. Immediate stop refers to applying control while servo is still ON and stopping the operation immediately.
At that time, the force command value is restricted by the Immediate Stop Force (Pn511).
- *2. If the position command is given or the motor runs continuously when servo is turned OFF, the position error accumulates and Err24.0, "error counter overflow," may occur. In addition, if servo is turned ON when the position error or external scale error is a large value, the motor may operate abruptly to perform a control operation to bring the error to 0. Take sufficient care when using while holding the position error or external scale error.
- *3. Decelerating refers to a period between when the motor is running and when the motor speed reaches 30 mm/s or less. Once the motor reaches a speed of 30 mm/s or less and moves to the after stop status, follow the subsequent operation based on the after stop status regardless of the motor speed.
- *4. The position error or external scale error will always be cleared to 0.

Pn507	Stop Selection with Main Power Supply OFF						All
Setting range	0 to 9	Unit	–	Default setting	0	Power OFF and ON	–

Explanation of Set Values

Set value	Explanation		
	During deceleration * 3	After stopping	Error counter
0	Dynamic brake operation	Dynamic brake operation	Clear * 4
1	Free-run	Dynamic brake operation	Clear * 4
2	Dynamic brake operation	Servo unlocked	Clear * 4
3	Free-run	Servo unlocked	Clear * 4
4	Dynamic brake operation	Dynamic brake operation	Hold * 2
5	Free-run	Dynamic brake operation	Hold * 2
6	Dynamic brake operation	Servo unlocked	Hold * 2
7	Free-run	Servo unlocked	Hold * 2
8	Immediate stop * 1	Dynamic brake operation	Clear * 4
9	Immediate stop * 1	Servo unlocked	Clear * 4

- ♦ If an error occurs when the main power supply is turned OFF, the operation will be based on the Stop Selection for Alarm Generation (Pn510). If the main power supply is turned OFF when Servo is ON, and if the Undervoltage Alarm Selection (Pn508) is set to 1, Err13.1, "main power supply undervoltage (AC cut-off detection)," will occur. Follow the Stop Selection for Alarm Generation (Pn510).
- *1. Immediate stop refers to applying control while servo is still ON and stopping the operation immediately.
At that time, the force command value is restricted by the Immediate Stop Force (Pn511).
- *2. If the position command is given or the motor runs continuously when the main power supply is turned OFF, the position error accumulates and Err24.0, "error counter overflow," may occur. In addition, if servo is turned ON when the position error is a large value, the motor may operate abruptly to perform a control operation to bring the error to 0. Take sufficient care when using while holding the position error.
- *3. Decelerating refers to a period between when the motor is running and when the motor speed reaches 30 mm/s or less. Once the motor reaches a speed of 30 mm/s or less and moves to the after stop status, follow the subsequent operation based on the after stop status regardless of the motor speed.
- *4. The position error or external scale error will always be cleared to 0.



8-6 Extended Parameters

Pn508	Undervoltage Alarm Selection All						
Setting range	0 to 1	Unit	–	Default setting	1	Power OFF and ON	–

Explanation of Set Values

Set value	Explanation
0	Turn the servo OFF based on the setting of the Stop Selection with Main Power Supply OFF (Pn507) and turn it back to servo ON by turning ON the main power supply.
1	Err13.1 "main power supply undervoltage" will occur and a trip will be caused.

Pn509	Momentary Hold Time All						
Setting range	70 to 2,000	Unit	1 ms	Default setting	70	Power OFF and ON	Yes

- ♦ Set main power supply alarm detection time.
- ♦ The main power supply OFF detection will be disabled if this is set to 2,000.

Pn510	Stop Selection for Alarm Generation All						
Setting range	0 to 7	Unit	–	Default setting	0	Power OFF and ON	–

Explanation of Set Values

Set value	Explanation		
	During deceleration * 3	After stopping	Error counter
0	Dynamic brake operation	Dynamic brake operation	Clear * 1
1	Free-run	Dynamic brake operation	Clear * 1
2	Dynamic brake operation	Servo unlocked	Clear * 1
3	Free-run	Servo unlocked	Clear * 1
4	Operation A: Immediate stop * 2 Operation B: Dynamic brake operation	Dynamic brake operation	Clear * 1
5	Operation A: Immediate stop * 2 Operation B: Free-run	Dynamic brake operation	Clear * 1
6	Operation A: Immediate stop * 2 Operation B: Dynamic brake operation	Servo unlocked	Clear * 1
7	Operation A: Immediate stop * 2 Operation B: Free-run	Servo unlocked	Clear * 1

- ♦ Set the operation to be performed after stopping or during deceleration when any protective function of the drive operates and an error occurs.

*1. The error counter is cleared when an alarm is reset.

*2. Operations A and B indicate whether immediate stop takes place upon error generation. If an immediate stop alarm is generated, immediate stop in operation A is executed.
If an alarm that does not support immediate stop is generated, immediate stop in operation B will take place.

*3. Decelerating refers to a period between when the motor is running and when the motor speed reaches 30 mm/s or less. Once the motor reaches a speed of 30 mm/s or less and moves to the after stop status, follow the subsequent operation based on the after stop status regardless of the motor speed.

Immediate Stop Operation when an Alarm that Supports Immediate Stop is Generated

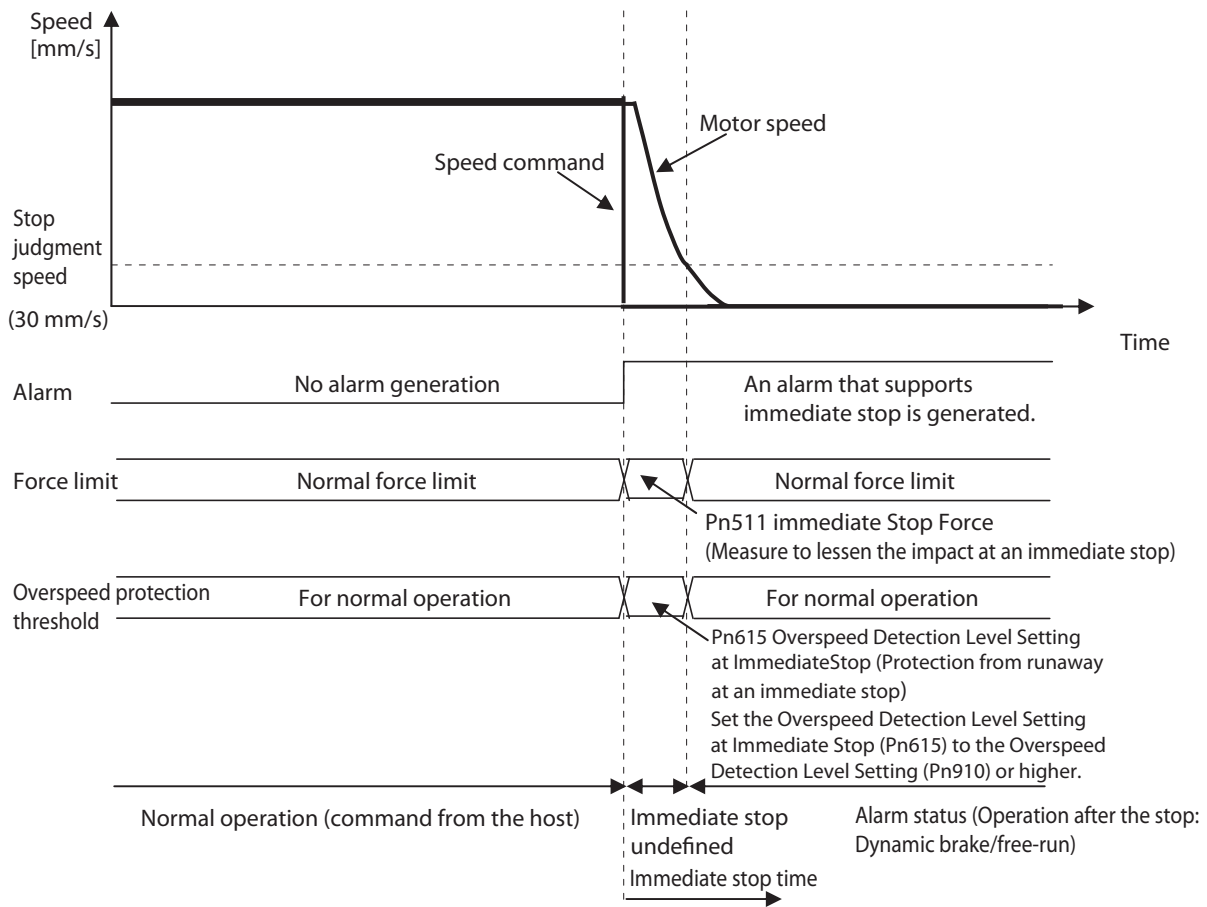

- ◆ If the actual speed is not 30 mm/s or less after the time set by the Alarm Generation Allowable Time Setting (Pn614) elapses, an immediate alarm status will occur. In addition, if an alarm that does not support immediate stop occurs inside the drive at immediate stop, an immediate alarm status will occur.
- ◆ Set the allowable overspeed level to Pn615, "Overspeed Detection Level Setting at Immediate Stop," as a protective measure against runaway at an immediate stop. Err26.1, "overspeed 2," if it occurs, will cause an immediate error trip because it is an error that does not support immediate stop. However, if the setting is below Pn910, "Overspeed Detection Level Setting," an immediate stop will not take place because Err26.1, "overspeed 2," will occur before Err26.0, "overspeed." In addition, if Err26.0 and Err26.1 are detected at the same time, Err26.0 will be displayed. However, an immediate stop will not take place because Err26.1 has also occurred internally.

Pn511	Immediate Stop Force						All
Setting range	0 to 500	Unit	%	Default setting	0	Power OFF and ON	-

- ◆ Set the force limit for the following cases.
 - Drive prohibition deceleration with the Stop Selection for Drive Prohibition Input (Pn505) set to 2.
 - Deceleration with the Stop Selection with Main Power Supply OFF (Pn507) set to 8 or 9.
 - Deceleration with the Stop Selection with Servo OFF (Pn506) set to 8 or 9.
- ◆ The normal force limit will be used if this parameter is set to 0.



8-6 Extended Parameters

Pn512	Overload Detection Level Setting						All
Setting range	0 to 500	Unit	%	Default setting	0	Power OFF and ON	-

- ♦ Set the overload detection level.
- ♦ If this setting is 0, the level is set to 115% of nominal force
- ♦ Internally there is a limit of 115%, so higher values are limited to 115%

Pn514	Overrun Limit Setting						Position
Setting range	0 to 1,000	Unit	0.1 pole pitch	Default setting	10	Power OFF and ON	-

- ♦ Set the allowable operating range for the position command input range.
- ♦ If the set value is exceeded, motor operation range setting protection is generated.

When position command is not input

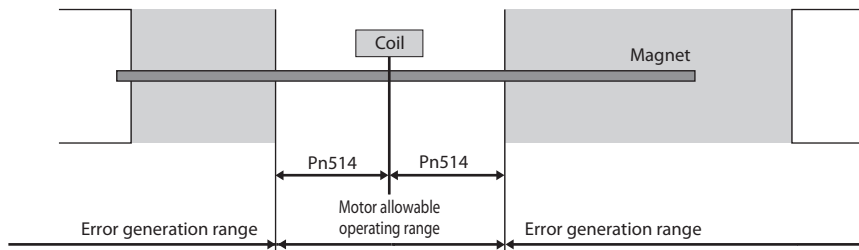

When position command is input

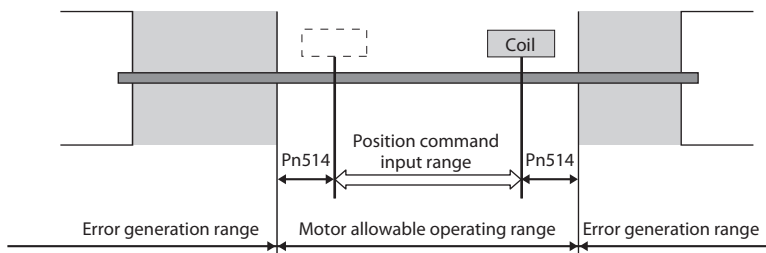

Pn515	Control Input Signal Read Setting						All
Setting range	0 to 3	Unit	-	Default setting	0	Power OFF and ON	Yes

Explanation of Set Values

Set value	Explanation
0	0.166ms
1	0.333ms
2	1 ms
3	1.666 ms

- ♦ Select the signal read cycle for control signal (digital input).

Pn516	Alarm Reset Condition Selection						All
Setting range	0 to 1	Unit	–	Default setting	0	Power OFF and ON	–

Explanation of Set Values

Set value	Explanation
0	120 ms
1	Follow the Control Input Signal Read Setting (Pn515).

♦ Select the signal confirmation time for alarm reset input signal (RESET).

Pn517	Error Counter Reset Condition Selection						Position
Setting range	0 to 4	Unit	–	Default setting	3	Power OFF and ON	–

Explanation of Set Values

Set value	Explanation
0	Disabled
1	Clears the error counter at level when the signal is shorted for 500 μs or longer.
2	Clears the error counter at level when the signal is shorted for 1 ms or longer.
3	Clears the error counter at edge when the signal changes from open to shorted for 100 μs or longer.
4	Clears the error counter at edge when the signal changes from open to shorted for 1 ms or longer.

♦ When set to 1 or 2, the minimum time width will be as follows.

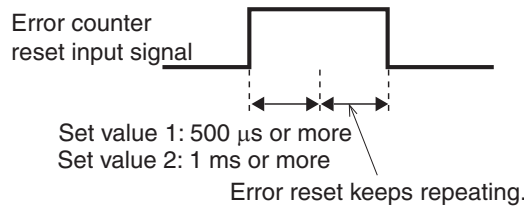

♦ When set to 3 or 4, the minimum time width will be as follows.

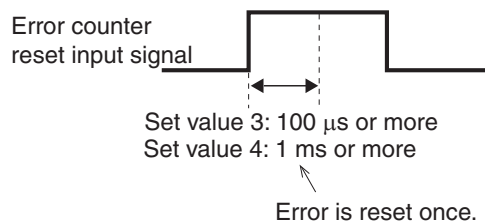

Pn518	Command Pulse Prohibition Input Setting						Position
Setting range	0 to 1	Unit	–	Default setting	1	Power OFF and ON	–

Explanation of Set Values

Set value	Explanation
0	Enabled
1	Disabled

♦ Enable or disable the pulse prohibition input signal (IPG).
When command pulse prohibition input is enabled, command pulse input count process is force stopped.

8-6 Extended Parameters

Pn519	Command Pulse Prohibition Input Read Setting							Position
Setting range	0 to 4	Unit	–	Default setting	0	Power OFF and ON	–	

Explanation of Set Values

Set value	Explanation
0	0.166 ms
1	0.333 ms
2	1 ms
3	1.666 ms
4	0.166 ms (No judgment of multiple matches)

- ♦ Select the signal read cycle for the pulse prohibition input signal (IPG).
- ♦ The signal status is updated when the signal status in each signal read cycle that has been set matches multiple times.
- ♦ You can lower the possibility of incorrect operation caused by noise by extending the signal read cycle. However, the responsiveness to signal inputs will be reduced.

Pn520	Position Setting Unit Selection							Position
Setting range	0 to 1	Unit	–	Default setting	0	Power OFF and ON	Yes	

Explanation of Set Values

Set value	Explanation
0	Command unit
1	Encoder unit

- ♦ Select the setting unit of Positioning Completion Range 1 and 2 (Pn431 and Pn442), and Error Counter Overflow Level (Pn014).

Pn521	Force Limit Selection					Position	Speed
Setting range	0 to 6	Unit	–	Default setting	1	Power OFF and ON	–

Explanation of Set Values

Force Limit Selection (Pn521)	Force limit switching input (FLSEL)	Force Limit Switching Setting (Pn523 and 524)	Forward direction analog limit input (PCL)	Reverse direction analog force limit input (NCL)	Forward direction force limit	Reverse direction force limit
0			0 to 10 V	-10 to 0 V	PCL	NCL
1	–	–			Pn013	
2	–	–			Pn013	Pn522
3	OFF	Enabled			Pn013	
	ON	Enabled			Pn522	
4			0 to 10 V	0 to 10 V	PCL	NCL
5			0 to 10 V	Not affected	PCL	NCL
6	OFF	–			Pn013	Pn522
	ON	–			Pn525	Pn526

- ◆ Set the force limit method for forward and reverse direction.
- ◆ If this parameter is set to 1, the forward and reverse force limit input will be limited by the No. 1 Force Limit (Pn013).
- ◆ When using force control, the No. 1 Force Limit (Pn013) will be the limit value for forward and reverse operation regardless of the setting of this parameter.

Pn522	No. 2 Force Limit					Position	Speed
Setting range	0 to 500	Unit	%	Default setting	500	Power OFF and ON	–

- ◆ Set the limit value for the output force (Pn013: No. 1 Force Limit, Pn522: No. 2 Force Limit) of the motor.
- ◆ Refer to information on the Force Limit Selection (Pn521) to select the force limits.
- ◆ During force control, maximum forces for both forward and reverse directions are limited. Settings in Force Limit Selection (Pn521) and No. 2 Force Limit (Pn522) will be ignored.
- ◆ Make the settings as a percentage of the rated force. [Example] Maximum force is limited to 150%

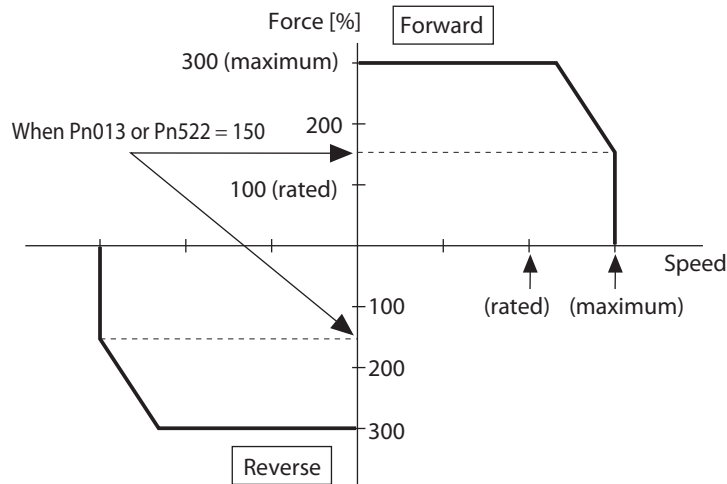

- ◆ Refer to "Force Control" (P.5-14) for more information on force limits and the force limit selection.



8-6 Extended Parameters

Pn523	Force Limit Switching Setting 1						Position	Speed
Setting range	0 to 4,000	Unit	ms/100%	Default setting	0	Power OFF and ON	-	

- ♦ Set the rate of change from force limit 1 to force limit 2
- ♦ When set to 0, switching takes place immediately.

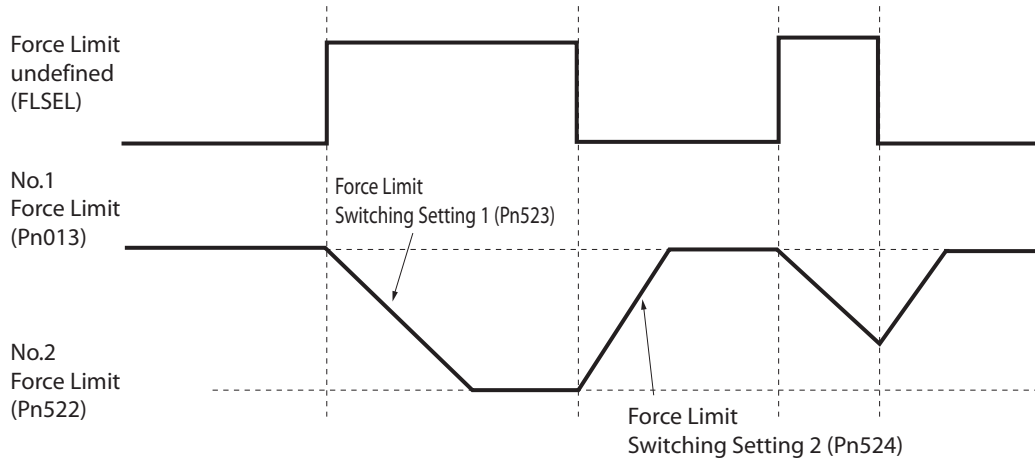

Pn524	Force Limit Switching Setting 2						Position	Speed
Setting range	0 to 4,000	Unit	ms/100%	Default setting	0	Power OFF and ON	-	

- ♦ Set values for this parameter are same as those for Force Limit Switching Setting 1 (Pn523).
- ♦ Set the rate of change from force limit 2 to force limit 1

Pn525	Forward External Force Limit						Position	Speed
Setting range	0 to 500	Unit	%	Default setting	500	Power OFF and ON	-	

- ♦ Set the forward external force limit upon force limit switching input when Pn521=6.

Pn526	Reverse External Force Limit						Position	Speed
Setting range	0 to 500	Unit	%	Default setting	500	Power OFF and ON	-	

- ♦ Set the reverse external force limit upon force limit switching input when Pn521=6.

Pn527	Analog Force Limit Scale						Position	Speed
Setting range	10 to 100	Unit	0.1 V/100%	Default setting	30	Power OFF and ON	-	

- ♦ Set the gain for the analogue force limit input.

Pn528	Default Display						All
Setting range	0 to 37	Unit	-	Default setting	1	Power OFF and ON	Yes

Explanation of Set Values

Set value	Explanation
0	Command position error
1	Motor speed
2	Position command speed
3	Speed control command
4	Force command
5	Total encoder pulses
6	Total command pulses
8	Feedback pulses
9	CONTROL mode
10	I/O signal status
11	Analog input value
12	Error factor, history
13	Warning number
14	Regeneration resistance load ratio
15	Overload load ratio
16	Mass ratio
17	Reason for no movement
18	Display of the number of I/O signal changes
20	Reserved
21	Absolute position
22	Monitor for the number of encoder communications errors
23	Display of axis numbers for communication
24	Position error (encoder unit)
25	Reserved
26	Reserved
27	P-N voltage
28	Soft version
29	Drive serial number
30	Reserved
31	Accumulative operation time
32	Reserved
33	Drive temperature
35	Safety status monitor
37	Linear motor status monitor

- ♦ Select the data to be displayed on the 7-segment LED on the front panel after the power supply is turned ON.
- ♦ For information on the display, refer to "Setting the Mode" (P.9-11).

Pn529	Reserved						All
Setting range	-	Unit	-	Default setting	-	Power OFF and ON	-

Pn530	Reserved						All
Setting range	-	Unit	-	Default setting	-	Power OFF and ON	-

8-6 Extended Parameters

Pn531	Axis Number All						
Setting range	0 to 127	Unit	–	Default setting	1	Power OFF and ON	Yes

♦ Set the axis number for communication.

Pn532	Command Pulse Input Maximum Setting Position						
Setting range	250 to 4,000	Unit	kpps	Default setting	4000	Power OFF and ON	Yes

♦ Set the maximum command pulse input.
♦ Err27.0 occurs if frequency exceeds this range

Pn533	Pulse Regeneration Output Limit Setting All						
Setting range	0 to 1	Unit	–	Default setting	0	Power OFF and ON	Yes

Explanation of Set Values

Set value	Explanation
0	Error detection disabled
1	Error detection enabled

♦ Set the detection of Err28.0 "pulse regeneration error".

Pn534	Reserved All						
Setting range	-	Unit	–	Default setting	-	Power OFF and ON	-

Pn535	Front Key Protection Setting All						
Setting range	0 to 1	Unit	–	Default setting	0	Power OFF and ON	Yes

Explanation of Set Values

Set value	Explanation
0	Front panel operation not blocked
1	Front panel operation blocked

♦ Set the operation limitation from the front panel.
♦ The operation limits depend on the mode. The operation limits are as follows.

Mode	Operation limits
MONITOR mode	All monitor data can be checked.
PARAMETER SETTING mode	Parameters cannot be changed. However, parameter set values can be checked.
EEPROM WRITE mode	Cannot be executed. (Will not be displayed)
AUXILIARY FUNCTION mode	Operations other than the release of the front key protection setting cannot be executed. (Will not be displayed)

8-7 Special Parameters

Pn600	Analog Force Feed-forward Gain Setting						Position	Speed
Setting range	0 to 100	Unit	0.1 V/100%	Default setting	0	Power OFF and ON	–	
♦ Set the input gain for analog force feed forward. 0 to 9 will disable the function.								
Pn602	Maximum speed error						Position	Speed
Setting range	0 to 20000	Unit	mm/s	Default setting	0	Power OFF and ON	–	
♦ Set here the maximum speed error level to give Err24.1 “Excessive speed error alarm”.								
Pn604	Jog Speed						All	
Setting range	0 to 500	Unit	mm/s	Default setting	50	Power OFF and ON	–	
♦ Set the command speed during JOG trial operation (speed control).								
Pn605	Gain 3 Effective Time						Position	
Setting range	0 to 10,000	Unit	0.1 ms	Default setting	0	Power OFF and ON	–	
♦ Set effective time of gain 3 of 3-step gain switching.								
Pn606	Gain 3 Ratio Setting						Position	
Setting range	100 to 1,000	Unit	%	Default setting	100	Power OFF and ON	–	
♦ Set gain 3 as a multiple of gain 1.								
Pn607	Force Command Value Offset						All	
Setting range	–100 to 100	Unit	%	Default setting	0	Power OFF and ON	–	
♦ Set offset force to add to force command.								
Pn608	Forward Direction Force Offset						All	
Setting range	–100 to 100	Unit	%	Default setting	0	Power OFF and ON	–	
♦ Set the value to add to the force command in the forward direction operation.								
Pn609	Reverse Direction Force Offset						All	
Setting range	–100 to 100	Unit	%	Default setting	0	Power OFF and ON	–	
♦ Set offset force to add to force command for reverse direction operation.								
Pn610	Function Expansion Setting						Position	
Setting range	0 to 63	Unit	–	Default setting	0	Power OFF and ON	–	
♦ Set each function per bit.								

8-7 Special Parameters

Bit	Function	Set value	
		0	1
bit 0	Instantaneous speed observer function	Disabled	Enabled
bit 1	Disturbance observer function	Disabled	Enabled
bit 2	Disturbance observer operation setting	Enabled at all time	Only when gain 1 is selected
bit 3	Mass ratio switching function	Disabled	Enabled
bit 4	Electric current response improvement function	Disabled	Enabled
bit 5	Analog thrust feed forward	Disabled	Enabled
bit 6	Current responsibility	Disabled	Enabled
bit 7	INP output limitation	Enabled	Disabled

♦ Set the decimal value that has been converted from bit.

[Example]

- ♦ Instantaneous speed observer function: enabled
- ♦ Disturbance observer function: enabled
- ♦ Disturbance observer operation setting: enabled at all time
- ♦ Mass ratio switching function: disabled
- ♦ Electric current response improvement function: enabled.
- ♦ If the settings are as described above, the bit will be 10,011, and the decimal value 19. Therefore, the set value will be 19.

Pn613	Mass Ratio 2						All
Setting range	0 to 10,000	Unit	%	Default setting	250	Power OFF and ON	-

- ♦ Set the second load mass as a percentage of the motor rotor mass.

Pn614	Alarm Generation Allowable Time Setting						All
Setting range	0 to 1,000	Unit	ms	Default setting	200	Power OFF and ON	-

- ♦ Set the allowable time for the immediate stop to complete when there is one alarm. If TB in the figure below is exceeded an alarm is forced
- ♦ The resolution is 2ms. For example if the setting is 11 the real value is 12.

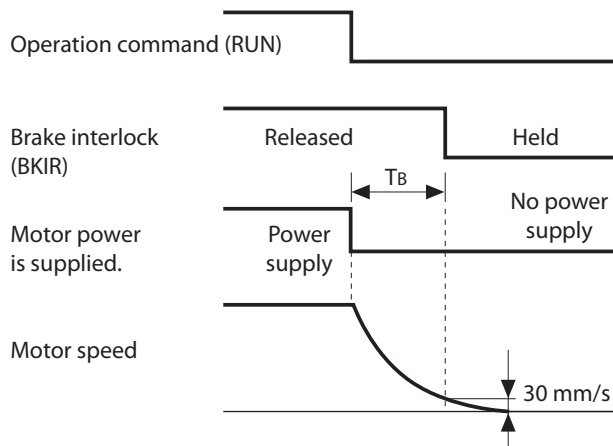

- ♦ TB in the above figure is the brake timing during operation or the time until the motor speed falls to 30 mm/s or lower, whichever is shorter.
- ♦ For details, refer to "Brake Interlock" (P.6-18).

Pn615	Overspeed Detection Level Setting at Immediate Stop All						
Setting range	0 to 20,000	Unit	mm/s	Default setting	0	Power OFF and ON	-

- ♦ Set overspeed detection level upon generation of immediate stop alarm.
- ♦ The overspeed detection level setting will be 1.2 times the maximum motor movement speed if this parameter is set to 0.
- ♦ This parameter should normally be set to 0. The setting should be changed only when it is necessary to reduce the overspeed detection level.

Pn617	Front Panel Parameter Write Selection All						
Setting range	0 to 1	Unit	-	Default setting	0	Power OFF and ON	Yes

Explanation of Set Values

Set value	Explanation
0	EEPROM write not performed when a parameter is changed from the front panel
1	EEPROM write performed at the same time

- ♦ Set the EEPROM write conditions when the front panel parameter is changed.

Pn618	Power Supply ON Initialization Time All						
Setting range	0 to 100	Unit	0.1 s	Default setting	0	Power OFF and ON	Yes

- ♦ Set initialization time after power supply ON to the standard 1.5 seconds plus some.

Pn620	Encoder Phase-Z Setting All						
Setting range	0 to 400	Unit	μs	Default setting	0	Power OFF and ON	Yes

- ♦ Set the encoder phase-Z regeneration width with time.
- ♦ You can output the phase-Z signal at least for the period of time that has been set if the phase-Z signal width is too short for detection due to the travel distance from the encoder.

Pn621	Serial Absolute Encoder Phase-Z Setting All						
Setting range	0 to 268435456	Unit	Pulse	Default setting	0	Power OFF and ON	Yes

- ♦ The encoder phase-Z output width can be extended.
- ♦ When you perform the pulse output using an encoder that uses the serial absolute interface, use this to set the intervals of phase-Z output based on the number of encoder phase-A output pulses (before quadruple multiplier).

Explanation of Set Values

Set value	Explanation
0	Phase Z is output only at the position where the encoder value is 0.
1 to 2 ²⁸	After the phase-Z output at the position where the encoder value is 0, phase Z is output in the set value pulse cycle. Phase Z is not output until the encoder value passes 0.

8-7 Special Parameters

Pn622	Phase-AB Regeneration Method Selection for Encoder of Phase-AB Output Type						<input type="checkbox"/> All	
Setting range	0 to 1	Unit	–	Default setting	0	Power OFF and ON	Yes	

♦ Select the regeneration method of pulse outputs OA and OB when an encoder of phase AB-output type is used.

Explanation of Set Values

Set value	Explanation
0	Without signal regeneration
1	With signal regeneration *1,*2

*1. Through outputs are always made for phase Z without signal regeneration.

*2. If the signal regeneration setting is selected, the duties of OA and OB are regenerated on the amplifier side and disturbance of waveforms can be suppressed. Take note, however, that this causes delays in phase Z.

Pn623	Disturbance Force Compensation Gain						<input type="checkbox"/> Position <input type="checkbox"/> Speed	
Setting range	–100 to 100	Unit	%	Default setting	0	Power OFF and ON	–	

♦ Set compensation gain for disturbance force.

Pn624	Disturbance Observer Filter Setting						<input type="checkbox"/> Position <input type="checkbox"/> Speed	
Setting range	10 to 2,500	Unit	0.01 ms	Default setting	53	Power OFF and ON	–	

♦ Set filter time constant for disturbance force compensation.

Pn627	Warning Latch Hold Time Selection						<input type="checkbox"/> All	
Setting range	0 to 10	Unit	–	Default setting	5	Power OFF and ON	Yes	

Explanation of Set Values

Set value	Explanation
0	Latch time infinite
1-10	Latch time in seconds

Pn631	Realtime Autotuning Estimated Speed Selection							All
Setting range	0 to 3	Unit	–	Default setting	1	Power OFF and ON	Yes	

Explanation of Set Values

Set value	Explanation
0	No changes are reflexed.
1	Changes are reflexed slowly (1 minute time constant).
2	Changes are reflexed gradually (few seconds time constant).
3	Changes are reflexed instantaneously (changes are applied as soon as they are detected).

Pn632	REALTIME AUTOTUNING CUSTOMIZATION mode Setting							All
Setting range	–32,768 to 32,767	Unit	–	Default setting	0	Power OFF and ON	–	

Explanation of Set Values

Set value	Explanation
bit 0, 1	Mass estimation enabled.
bit 2, 3	Update of the mass estimation enabled.
bit 4, 5, 6	Update of friction compensation and unbalanced load enabled.
bit 7	Update of gain adjustment.
bit 8	Forces the “fixed parameter”.
bit 9, 10	Enables the gain switching.

Pn637	Vibration Detection Threshold							All
Setting range	0 to 1,000	Unit	0.1%	Default setting	0	Power OFF and ON	–	

- ♦Set the vibration detection threshold.
- ♦If force vibration that exceeds this setting is detected, the vibration detection warning will occur.

Pn638	Warning Mask Setting							All
Setting range	–32,768 to 32,768	Unit	–	Default setting	0	Power OFF and ON	Yes	

- ♦Set the warning detection mask setting. See chapter 11-2 for detail of the bits.
- ♦If you set the corresponding bit to 1, the corresponding warning detection will be disabled.

Pn639	Reserved							All
Setting range	–	Unit	–	Default setting	–	Power OFF and ON	–	

Pn640	Reserved							All
Setting range	–	Unit	–	Default setting	–	Power OFF and ON	–	

Pn641	Reserved							All
Setting range	–	Unit	–	Default setting	–	Power OFF and ON	–	

8-8 Linear Motor And Encoder Setting Parameters

Pn900	Reserved						All
Setting range	-	Unit	-	Default setting	-	Power OFF and ON	-

*Do not change the setting.

Pn901	Encoder resolution						All
Setting range	0.000 to 1048576	Unit	μm/count	Default setting	0.000	Power OFF and ON	Yes

*Set the encoder resolution in μm/count (after x4 multiplication in case of A/B encoder).

Pn902	Pole pitch						All
Setting range	0.00 to 327.67	Unit	0.01mm	Default setting	0.00	Power OFF and ON	Yes

*Set the linear motor pole pitch value.

Pn903	Reserved						All
Setting range	-	Unit	-	Default setting	-	Power OFF and ON	-

*Do not change the setting.

Pn904	Linear motor coil weight						All
Setting range	0 to 32767	Unit	0.01kg	Default setting	0	Power OFF and ON	Yes

*Set the linear motor coil weight.

Pn905	Motor nominal force						All
Setting range	0.0 to 327,67	Unit	0.1N	Default setting	0.00	Power OFF and ON	Yes

*Set the linear motor nominal force.

Pn906	Motor rated rms current						All
Setting range	0.0 to 32767	Unit	0.1A	Default setting	0.0	Power OFF and ON	Yes

*Set the linear motor rated rms current.

Pn907	Motor peak absolute current						All
Setting range	0.0 to 32767	Unit	0.1A	Default setting	0.0	Power OFF and ON	Yes

*Set the linear motor peak current as absolute peak, not rms.

*If the data is as peak rms current, the relation is:

$$Pn907 = \text{Motor - peak - rms - current} \times \sqrt{2}$$

Pn908	Motor inductance						All
Setting range	0.00 to 32767	Unit	0.01mH	Default setting	0.00	Power OFF and ON	Yes

*Set the “per phase“ motor inductance.

8-8 Linear Motor And Encoder Setting Parameters

Pn909	Motor resistance						All
Setting range	0.00 to 327.67	Unit	0,01Ω	Default setting	0.00	Power OFF and ON	Yes

*Set the “per phase“ motor resistance.

Pn910	Overvelocity level						All
Setting range	0 to 20000	Unit	mm/s	Default setting	0	Power OFF and ON	Yes

*Set the velocity level to detect the error 26.0 (Overspeed protection).

*If this parameter is set to 0, error 60.0 (motor setting error) is generated.

Pn911	Carrier frequency						All
Setting range	0 to 1	Unit	-	Default setting	See Note below	Power OFF and ON	Yes

*Set values are:

Set value	Explanation
0	6KHz
1	12KHz

Default setting is 1 for 200V, 100W and 200W drive and 0 for the rest of the models.

Working at 6KHz, the drive gives more current but result in a more noisy motor operation. If the encoder has low resolution or the electrical noise is high, use 12KHz.

Pn912	Current response auto-adjustment						All
Setting range	0 to 100	Unit	%	Default setting	30	Power OFF and ON	Yes

*Default setting is 30 for 200V, 100W and 200W drive and 60 for the rest of the models.

*Automatically adjust the level of Pn913 (Proportional) and Pn914 (Integral) according to this value.

*Recommended values are 40 if Pn911=1 (carrier frequency 12KHz) and 80 if Pn911=0 (carrier frequency 6KHz).

*Set 0 to adjust manually Pn913 and Pn914.

Pn913	Current loop proportional gain						All
Setting range	0 to 32767	Unit	-	Default setting	50	Power OFF and ON	-

*Set here the current loop proportional gain. If Pn912<>0 this value is set automatically.

Pn914	Current loop integral gain						All
Setting range	0 to 32767	Unit	-	Default setting	10	Power OFF and ON	-

*Set here the current loop integral gain. If Pn912<>0 this value is set automatically.

Pn915	Current loop filter time constant						All
Setting range	0.00 to 25.00	Unit	0.01ms	Default setting	0.00	Power OFF and ON	-

*Set here the time constant for the force command filter. If the value is 0 the filter is disabled.

Pn916	Reserved						All
Setting range	-	Unit	-	Default setting	-	Power OFF and ON	-

8-8 Linear Motor And Encoder Setting Parameters

*Do not change the setting

Pn917	Reserved						<input type="button" value="All"/>
Setting range	-	Unit	-	Default setting	-	Power OFF and ON	-

*Do not change the setting..

Pn918	Reserved						<input type="button" value="All"/>
Setting range	-	Unit	-	Default setting	-	Power OFF and ON	-

*Do not change the setting.

Pn919	Reserved						<input type="button" value="All"/>
Setting range	-	Unit	-	Default setting	-	Power OFF and ON	-

*Do not change the setting.

Pn920	Magnetic phase detection method						<input type="button" value="All"/>
Setting range	0 to 3	Unit	-	Default setting	0	Power OFF and ON	Yes

*In a linear motor, it is necessary to detect the magnetic angle between the magnets and the motor coil. Select here the detection method:

Set value	Explanation
0	No detection. This setting generates the motor abnormality error.
1	Direct measurement via Hall Sensor. To use this option it is necessary to connect the Hall sensor to a Serial Converter (Pn323=1) and use a SinCos encoder.
2	Magnetic phase detection. On the first run after power-on, the linear servo-drive estimates the Magnetic phase. This sequence may take a few seconds and the motor may move a few mm.
3	Magnetic phase detection restoration. When using an absolute encoder (Pn323=2) the drive can memorize the magnetic phase detected by using method 2 and then restore the value (by setting this method).

Pn921	Magnetic phase value						<input type="button" value="All"/>
Setting range	0 to 360	Unit	Electric angle	Default setting	0	Power OFF and ON	Yes

*When using Hall sensors (Pn920=1), set here the angle between the motor and the motor phases. When using the standard Hall sensor this value must be 0.

Pn922	Magnetic phase detection command Maximum time						<input type="button" value="All"/>
Setting range	0 to 200	Unit	ms	Default setting	200	Power OFF and ON	-

*Maximum time that the force command is applied when magnetic phase detection sequence is executed (Pn920=2).

Pn923	Magnetic phase detection Force command						<input type="button" value="All"/>
Setting range	0 to 300	Unit	%	Default setting	50	Power OFF and ON	-

8-8 Linear Motor And Encoder Setting Parameters

*Force command that is applied to the motor when magnetic phase detection sequence is executed (Pn920=2).

Pn924	Magnetic phase detection maximum movement						All
Setting range	0 to 32767	Unit	Pulse(s)	Default setting	100	Power OFF and ON	-

*The force command during magnetic phase detection sequence is set to 0 if the motor moves more that this amount while the force set in Pn923 is applied, regardless of the time set in Pn922

Pn925	Magnetic phase detection movement for Stop judgement						All
Setting range	0 to 32767	Unit	Pulse(s)	Default setting	40	Power OFF and ON	-

*During the Magnetic phase detection sequence, the motor is considered stopped when moves less than Pn925 pulses in 2ms and continues stopped for Pn926 ms.

Pn926	Magnetic phase detection time for Stop judgement						All
Setting range	0 to 32767	Unit	ms	Default setting	40	Power OFF and ON	-

*During the Magnetic phase detection sequence, the motor is considered stopped when moves less than Pn925 pulses in 2ms and continues stopped for Pn926 ms.

Pn927	Magnetic phase detection time limit						All
Setting range	0 to 32767	Unit	ms	Default setting	1000	Power OFF and ON	-

*Set the maximum time for the motor to stop during the magnetic phase detection sequence before giving alarm 61.1 (magnetic phase estimation abnormality 2).

Pn928	Magnetic phase detection Force filter time						All
Setting range	0.00 to 25.00	Unit	0.01ms	Default setting	1.00	Power OFF and ON	-

*Set the time constant for the force filter used during the magnetic phase detection sequence. If the value is 0 the filter is disabled.

Pn929	Motor overload curve selection						All
Setting range	0 to 7	Unit	-	Default setting	0	Power OFF and ON	-

*Selects between various overload curves for the motor thermal protection. Selects the suitable one depending on the motor model, ambient temperature and mechanical installation.

*If you install the motors with the recommended installation (natural cooling and a table with the recommended dimensions), the recommended setting are next:

Set value	Explanation
0	Overload curve disabled. The overload curve will correspond to the one for the drive. The motor has to be protected by using the internal thermal resistor.
1	For motors R88L-EC-GW-0303/-0306/-0309
2	For motors R88L-EC-GW-0503/-0506/-0509
3	For motors R88L-EC-GW-0703/-0706/-0709
4	For motors R88L-EC-FW-0303/-0306
5	For motors R88L-EC-FW-0606/-0609/-0612
6	For motors R88L-EC-FW-1112/-1115
7	Corresponds to the overload curve for the drive protection.

8-8 Linear Motor And Encoder Setting Parameters

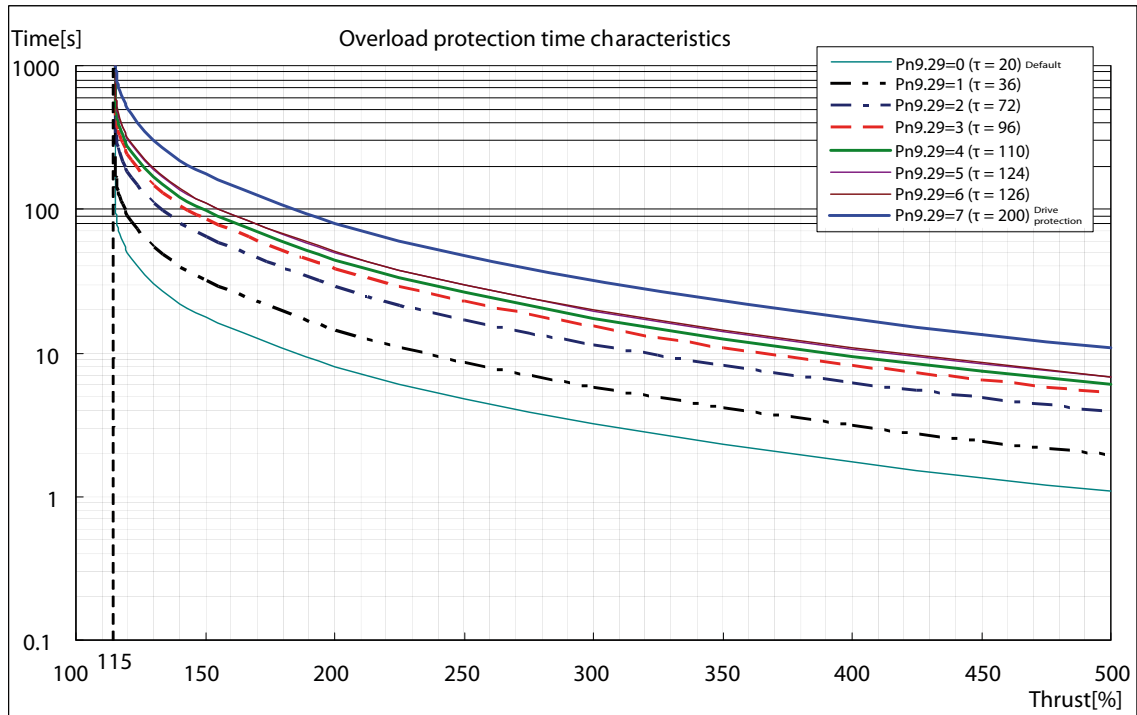

9

Operation

This chapter explains the operating procedures and how to operate in each mode.

9-1	Operational Procedure	9-2
9-2	Preparing for Operation	9-3
	Items to Check Before Turning ON the Power Supply.....	9-3
	Turning ON Power Supply	9-4
	Checking Displays	9-4
	Linear motor and Encoder Setup.....	9-5
	Trial operation	9-8
9-3	Using the Front Display	9-10
9-4	Setting the Mode.....	9-11
	Changing the Mode.....	9-11
	MONITOR Mode	9-12
	PARAMETER SETTING Mode	9-25
	PARAMETER WRITE Mode	9-27
	AUXILIARY FUNCTION Mode.....	9-28
9-5	Trial Operation	9-35
	Preparation for Trial Operation	9-35
	Trial Operation in POSITION CONTROL Mode.....	9-36
	Trial Operation in SPEED CONTROL Mode.....	9-37
	Trial Operation in FORCE CONTROL Mode	9-38

9-1 Operational Procedure

Turn ON the power supply after the correct installation and wiring to check the operation of the individual motor and drive.

Then make the function settings as required according to the use of the motor and drive.

If the user parameters are set incorrectly, there is a risk of an unpredictable motor operation, which is dangerous. Set the parameters securely according to the setting methods in this manual.

Item	Contents	Reference
Mounting and installation	Install the motor and drive according to the installation conditions. (Do not install the load in the linear motor system before checking the non-load operation).	Chapter 4, 4-1
Wiring and connections	Connect the motor and drive to the power supply and peripheral equipment. Specified installation and wiring conditions must be satisfied, particularly for models conforming to the EC directives. Connect limit switches to prevent overrun of the motor and Emergency stop to allow a quick stop of the motor.	Chapter 4, 4-2
Preparing for operation	Check the necessary items and then turn ON the power supply. Check on the display to see whether there are any internal errors in the drive.	Chapter 9, 9-2
Motor and Encoder setup	Setup the linear motor and Encoder with CX-Drive.	Chapter 6, 6-17, 6-18, 6-19
Function settings	By means of the user parameters, set the functions according to the operating conditions.	Chapter 8
Trial operation	Check to see whether protective functions, such as the immediate stop and operational limits, work properly. First, check the linear motor system operation with no-load condition. Then turn the power supply OFF and connect the load. Turn ON the power supply again, and check the operation at low and high speed.	Chapter 9, 9-5
Adjustment	Manually adjust the gain if necessary. Further adjust the various functions to improve the control performance.	Chapter 10
Operation	Operation can now be started. If any problems should occur, refer to "Chapter 11, Error and Maintenance".	Chapter 11

9-2 Preparing for Operation

This section explains the procedure to prepare the linear system for operation following installation and wiring of the motor and drive. It explains items to check both before and after turning ON the power supply.

Items to Check Before Turning ON the Power Supply

Checking Power Supply Voltage

- ♦ Check to be sure that the power supply voltage is within the ranges shown below.
 - R88D-KT01L-L/KT02L-L/KT04L-L (Single-phase 100-VAC input)
 - Main circuit power supply: Single-phase 100 to 115 VAC (85 to 127) 50/60 Hz
 - Control circuit power supply: Single-phase 100 to 115 VAC (85 to 127) 50/60 Hz
 - R88D-02H-L/04H-L/08H-L/10H-L/15H-L (Single-phase or single-phase/3-phase 200-VAC input)
 - Main circuit power supply: Single-phase or single-phase/3-phase 200 to 240 V (170 to 264 V) 50/60 Hz
 - Control circuit power supply: Single-phase 200 to 240 VAC (170 to 264 V) 50/60 Hz
 - R88D-KT20H-L (3-phase 200-VAC input)
 - Main circuit power supply: 3-phase 200 to 230 VAC (170 to 253 V) 50/60 Hz
 - Control circuit power supply: Single-phase 200 to 230 VAC (170 to 253 V) 50/60 Hz
 - R88D-KT06F-L/KT10F-L/KT15F-L/KT20F-L/KT30F-L/KT50F-L (3-phase 400-VAC input)
 - Main circuit power supply: 3-phase 380 to 480 VAC (323 to 528 V) 50/60 Hz
 - Control circuit power supply: 24 VDC \pm 15%

Checking Terminal Block Wiring

- ♦ The main circuit power supply inputs (L1/L3 or L1/L2/L3) must be properly connected to the terminal block.
- ♦ The control circuit power supply inputs (L1C/L2C) must be properly connected to the terminal block.
- ♦ The motor's U, V, and W power lines and the green/yellow (\oplus) must be properly connected to the terminal block.
- ♦ Check the Encoder wiring and, if used, Serial Converter unit wiring.

Checking the Motor

- ♦ The motor side power lines and the power cables must be securely connected.
- ♦ The linear motor is not a working system by itself. It needs to be installed with the proper elements before using it.
- ♦ Make sure the linear motor system is properly installed with all its elements and with the right distances and tolerances.
- ♦ If used, make sure that the Hall sensor is properly installed in the motor coil.
- ♦ Use always flexible-type cables for the motor power connection.

Checking the Encoder Wiring

- ♦ The encoder cable must be securely connected to the encoder connector (CN4) at the drive side.
- ♦ The encoder cable must be securely connected to the encoder connector at the encoder side.
- ♦ The encoder cable must be securely connected to the encoder connector (CN4) for the A/B Encoder or to Serial Converter Unit for the SinCos Encoder.
- ♦ The cables to the Serial Converter Unit must be securely connected.
- ♦ Use always flexible-type cables.

Checking the Control I/O Connector

- ♦ The control cable must be securely connected to the control I/O connector (CN1).
- ♦ The operation command (RUN) must be OFF.

Turning ON Power Supply

- ♦ First carry out the preliminary checks, and then turn ON the control circuit power supply. It makes no difference whether or not the main circuit power supply is turned ON.
- ♦ The alarm output (/ALM) will take approx. 2 seconds to turn ON after the power supply has been turned ON. Do not attempt to detect an alarm using the Host Controller during this time. (If power supply is turned ON while the Host Controller is connected.)

Checking Displays

Displays on the Drive

- ♦ The following will appear on the display area on the drive when the power supply is turned ON.

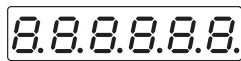

↓ Approx. 2 s



↓ 0.6 s



↓ 0.6 s



Default display (determined by the Default Display setting of parameter Pn528.)

Linear motor and Encoder Setup

If the motor and encoder setup is not done, the drive will report an “Abnormality setting error”: Error 60.x.

Setup the linear motor and encoder by following the setup wizard in CX-Drive.

To start the linear motor setup, click in the right icon in the “project tree”:

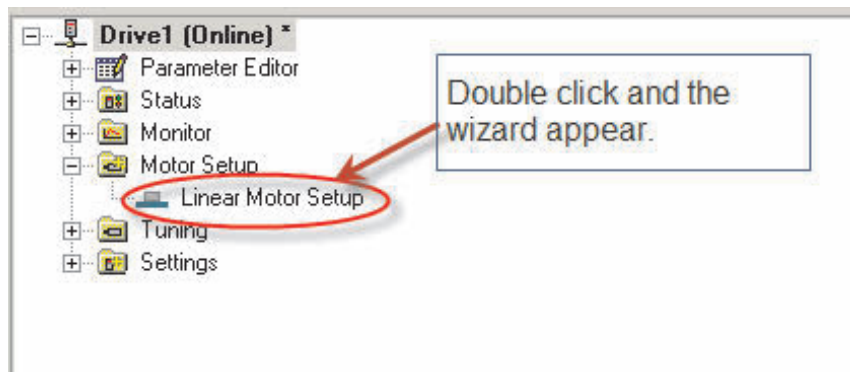

Note: The final appearance may change.

Then the first step in the wizard is opened: Linear motor selection.

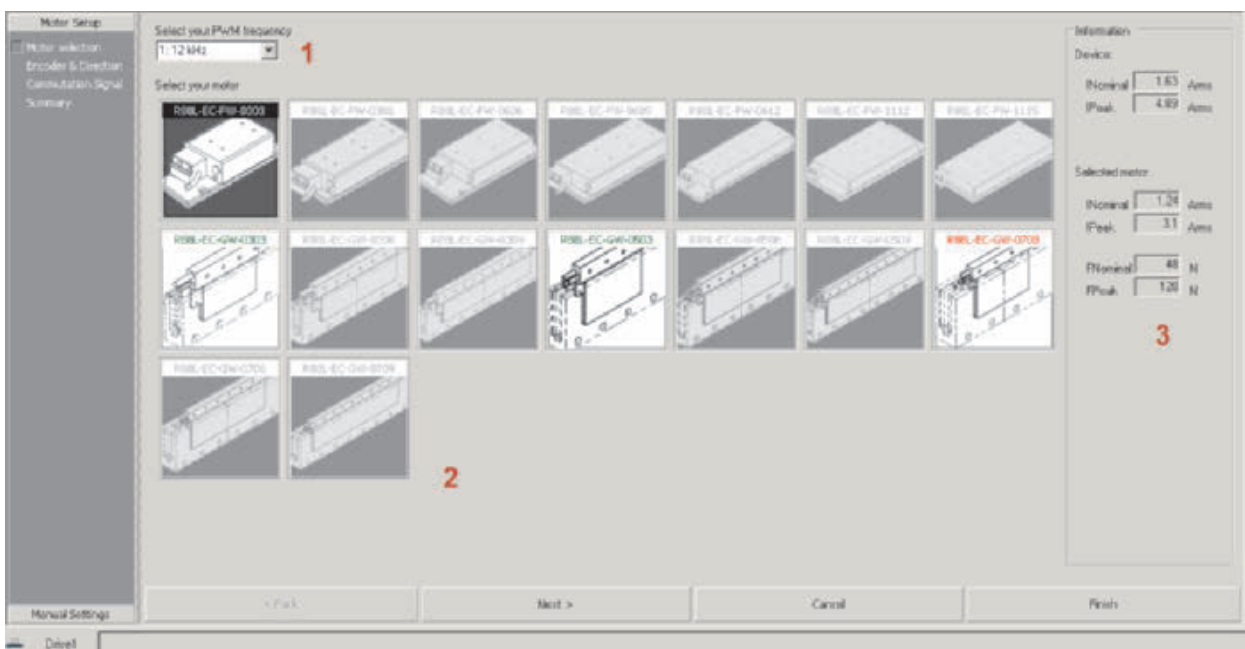

To configure the linear motor you have to follow next steps:

1: Select the Drive switching frequency.

Most of the drive can work at 6KHz or at 12KHz. Selecting 6KHz the drive drains more current but the acoustic noise is higher.

2: Select the motor from the thumbnails.

9-2 Preparing for Operation

Depending on the servodrive and the switching frequency, the motors are represented by the next color code:

- Grey: Not suitable.
- Red: Limited performance (Force peak is reduced).
- Green: Optimum combination.
- Orange: Overdimensioned drive.

3: Verify the selection.

That selection shows the currents and force of the selected drive and motor.

Once the motor is selected, click “Next“ to go to next tab: Encoder setup.

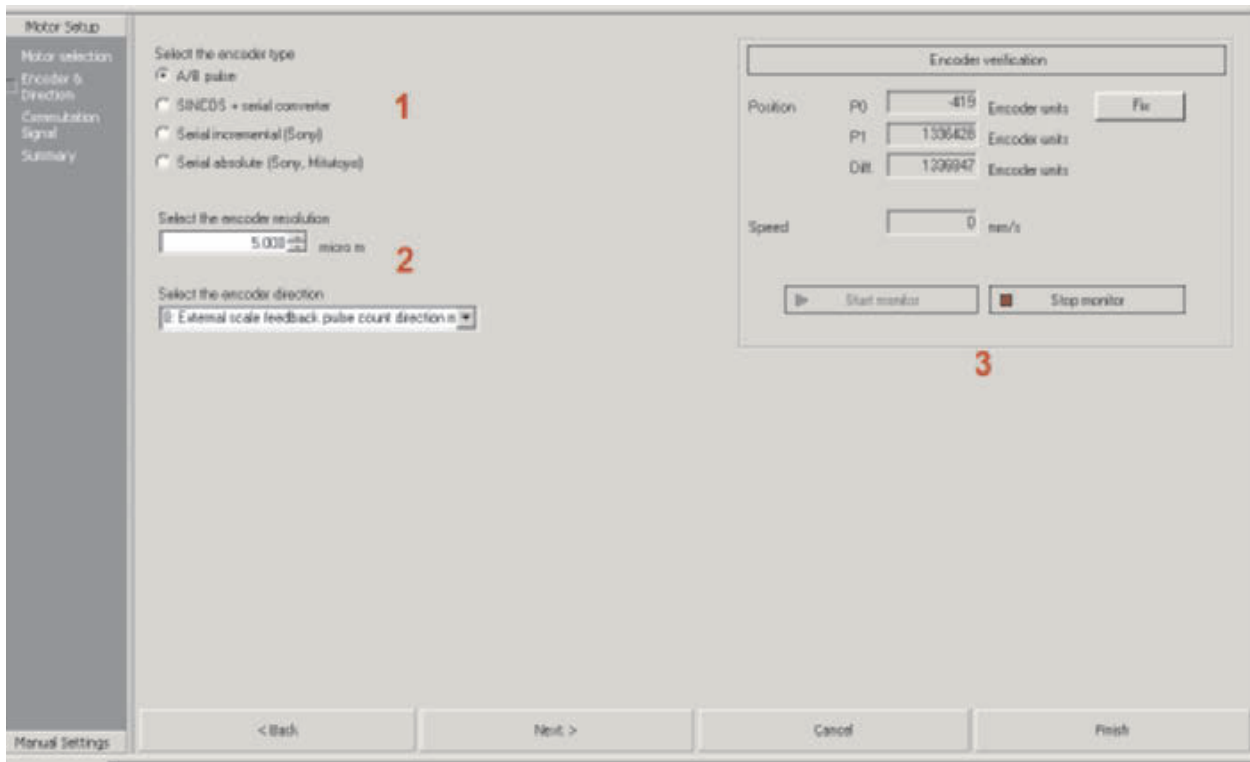

1: Select the encoder type: 4 different types are available.

2: Select the encoder resolution (after quadrature in case of A/B encoder) and the count direction.

Note that, after changing those values, it is necessary to power the servo off and on again for those changes to take effect.

3: Verify the encoder counting and direction: You can monitor the encoder counting direction by monitoring the sign of the speed or the increment in position when you move the linear motor either by hand or by other means.

By default, the positive direction is towards the motor cable.

It is also possible to check the encoder resolution by next method:

- P0 and P1 reflects the encoder position.
- When you click “fix“, the value in P0 is fixed while P1 continues updating the current position.
- Move the motor by hand a known increment (eg. 100mm) and verify that the mounting in “Diff.“ corresponds with the expected amount of encoder counts.

Once you confirm that the encoder is properly set, click “Next“ and go to the “Commutation signal” window.

To control a servomotor, it is necessary to know the electrical angle between the motor winding and the magnets. Select here the method to find this phase. The available options depends on the encoder type:

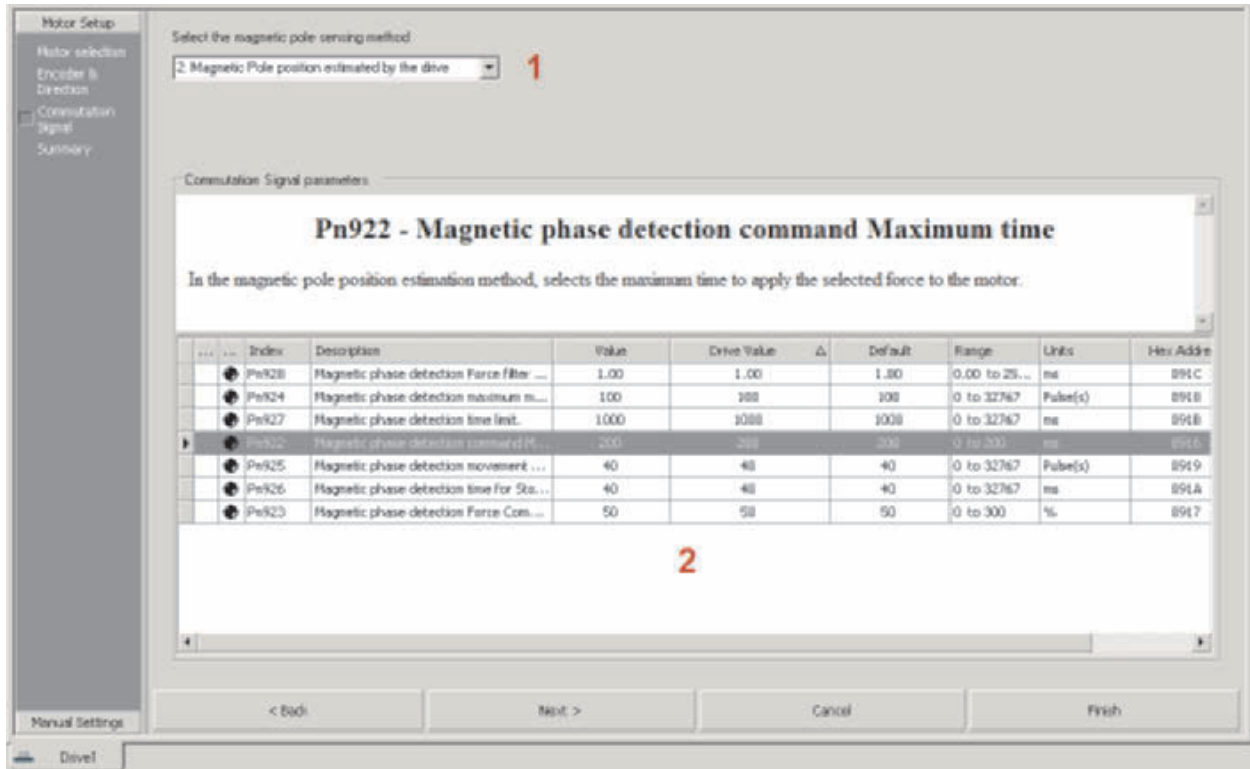

1: Select the method to establish the motor electrical angle. The options are:

- Estimation sequence in the drive: First “run” after power on, the drive makes a “commutation signal finding sequence” where the motor moves a small movement to estimate the electrical angle. This method is available for all encoder types.
- Direct measurement via Hall sensors installed in the motor. This method is only available for SinCos encoder via Serial Converter.
- Restoration method: A previously detected electrical phase is restored at power up. This method is only available for Absolute linear encoders.

2: Setting area.

In case of selecting “commutation signal finding sequence”, you can set various parameters to ensure a proper detection sequence.

Finally, click “Finish” to finish the setup.

Note: Most of the motor and encoder setup parameters needs a power off-on to become effective.

Trial operation

Once the drive report no errors you can make a trial operation either with the Jog function via the display or with the trial operation via CX-Drive.

Make sure the emergency switch is connected and ready for a quick stop in case of overrun.

Steps to follow operation:

- ♦ Before start the test run operation make sure the RUN input is OFF.
- ♦ Select Test Run from the project tree.

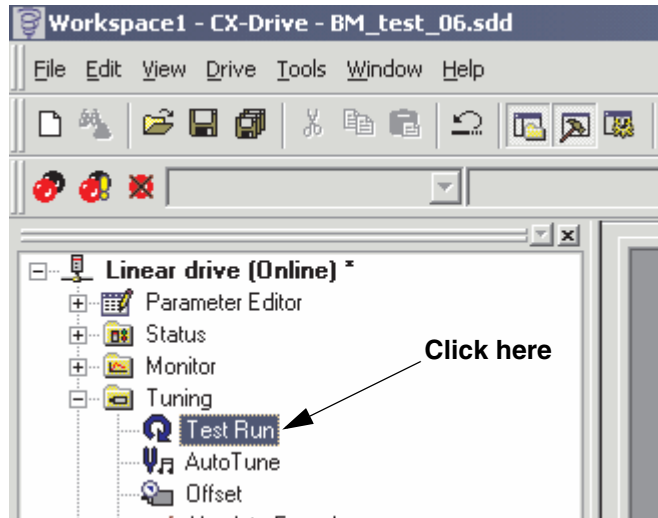

- ♦ This window will appear. In this window must adjust jog speed (mm/s), acceleration time (ms/1000mm/s) and deceleration time (ms/1000mm/s). Adjust the speed to low values.

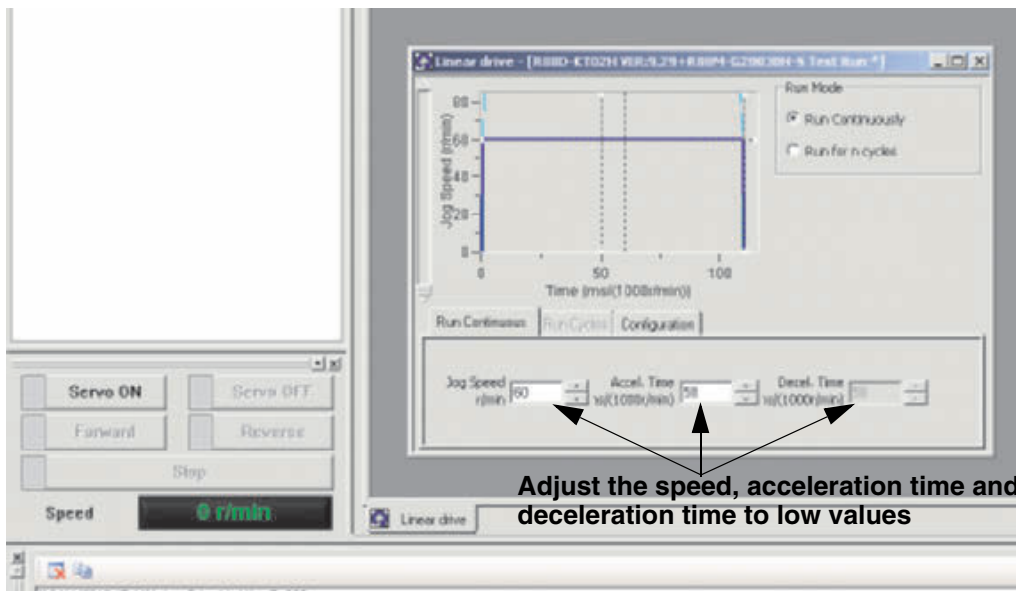

- ♦ Click in "Servo ON" the motor will be energized.

9
Operation

- Click either Forward or Reverse and the motor will move at the commanded speed.

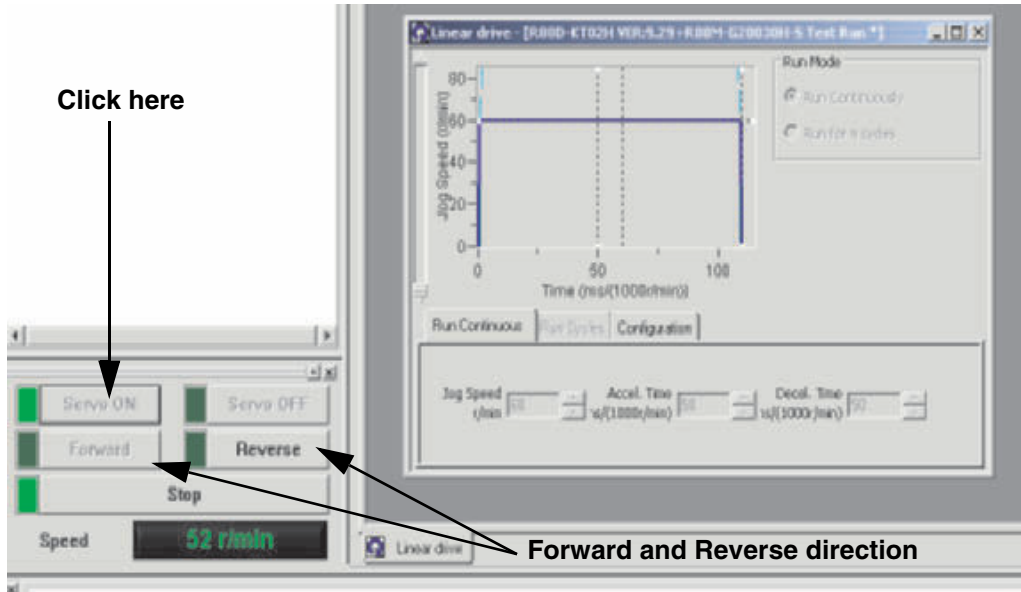

- The POT and NOT inputs do not work during test run operation so, provide a means to quickly stop the motor in case of crash.
- It is possible to program a cyclic operation in position control by selecting from the configuration tab:

Jog Function:	STEP
Jog Loop:	ON
Step distance:	Any distance that is smaller than the linear motor stroke

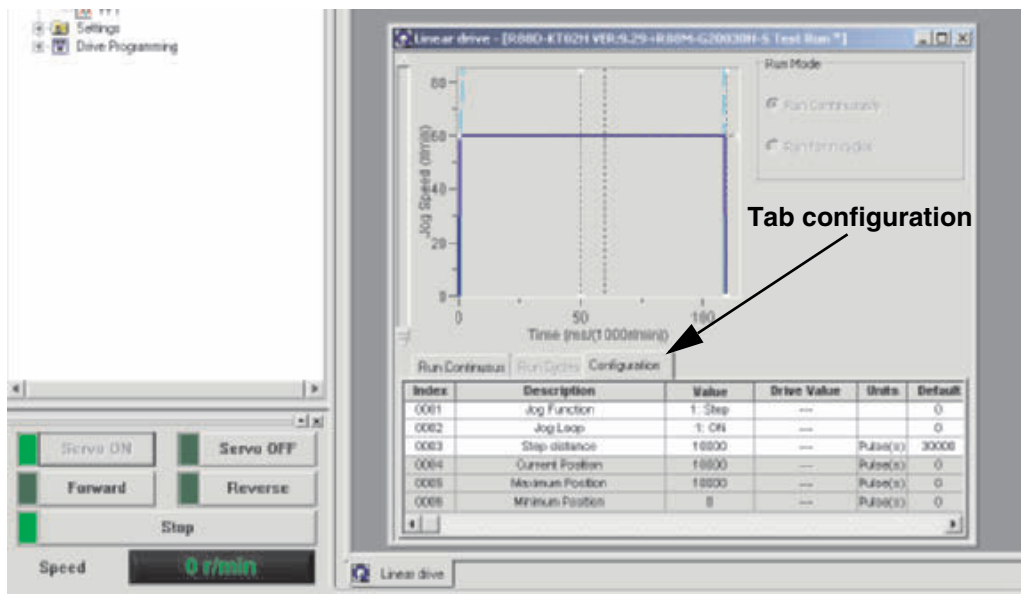

- By clicking Forward (Reverse) button the motor will move an the incremental “Step distance” and back in position control starting in the Forward (Reverse) direction.
- Warning:** The Forward and Reverse operation may be interrupted if other operations with CX-Drive like trace, parameter change,etc are executed at the same time than the Step operation causing a crash in the linear motor.
- Once the operation has ben finished, click the Stop and Servo OFF buttons.

9-3 Using the Front Display

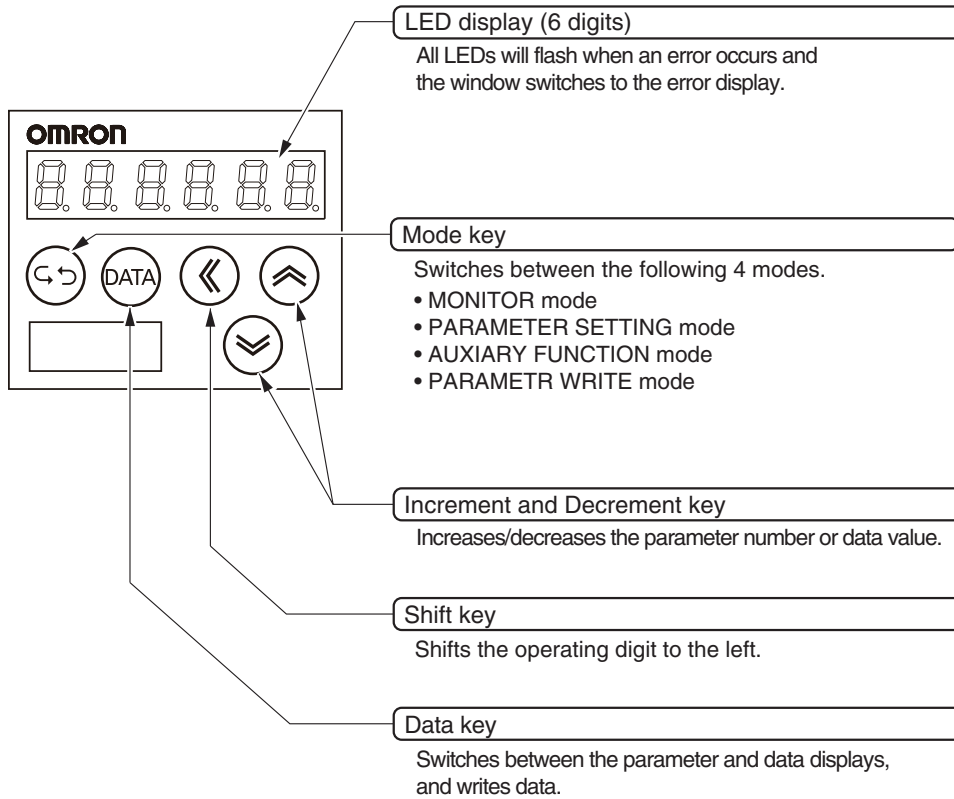

9-4 Setting the Mode

Changing the Mode

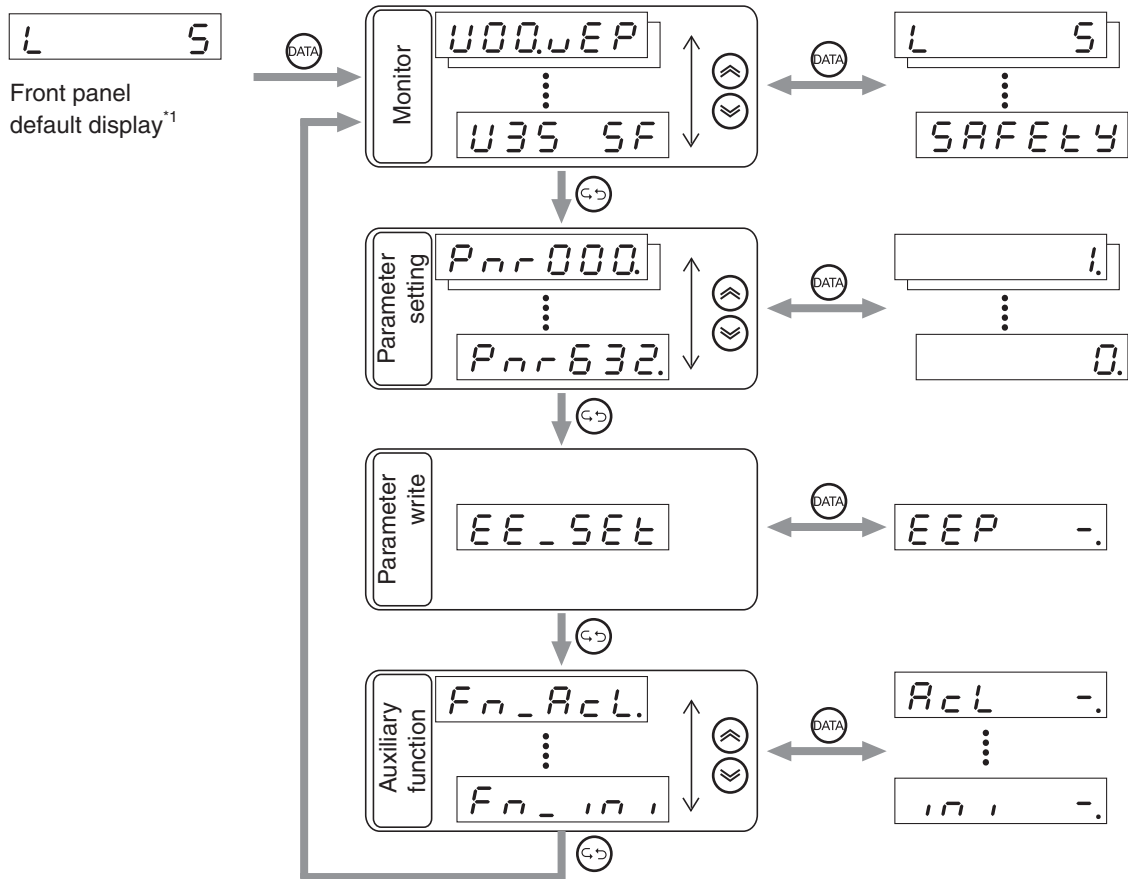

*1. The display will be based on the Default Display (Pn528) setting after the power supply is turned ON.

MONITOR Mode

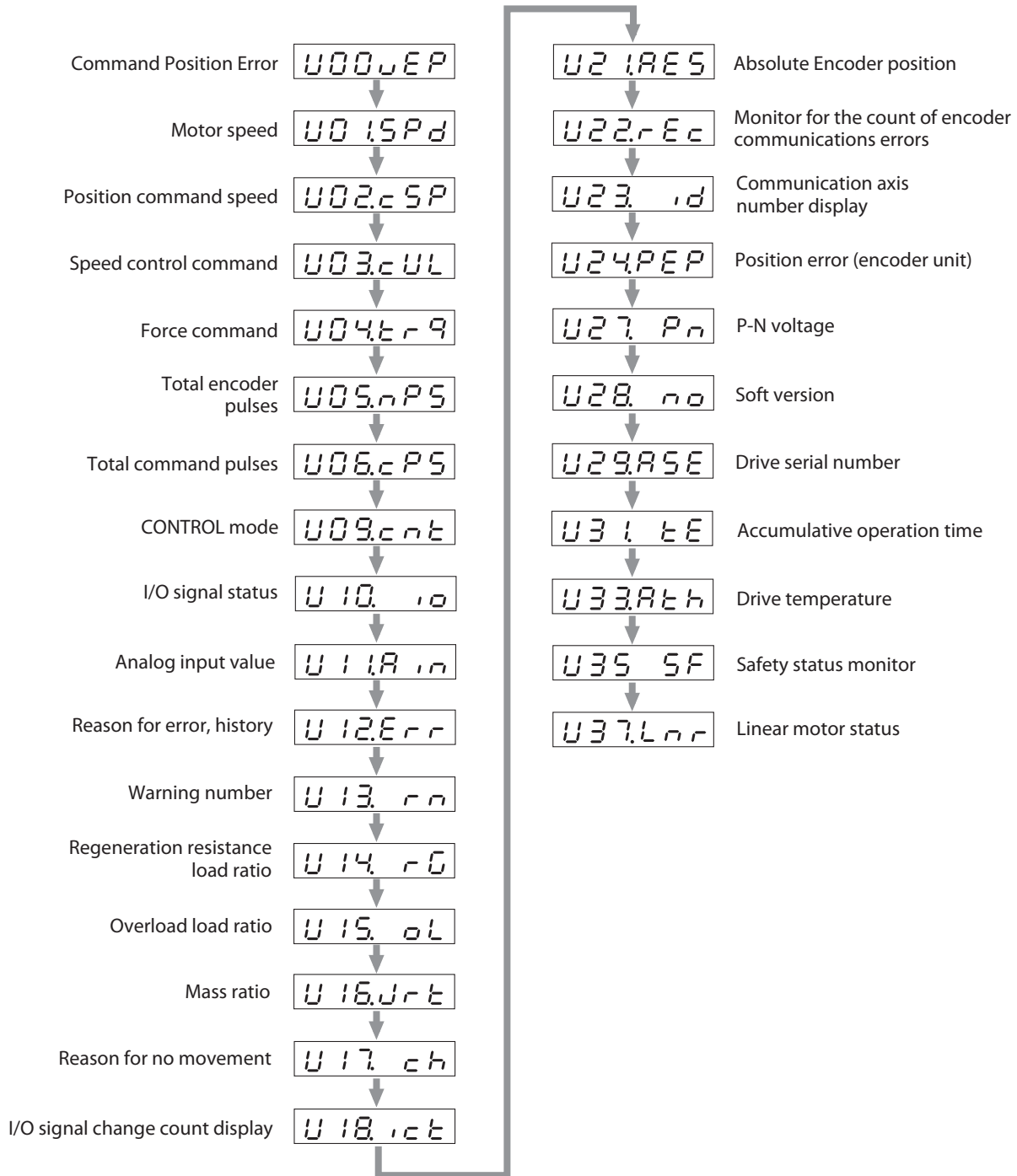

When is pressed, the display position will move in the direction of the arrow.
 When is pressed, it will move in the opposite direction.

- ♦ The motor speed will be displayed the first time the power supply is turned ON after purchase. To change the initial display when the power supply is turned ON, change the setting for the Default Display (Pn528). For details, refer to Pn528 "Default Display" (P.8-54).

- ♦ You can locate the monitor in the corresponding block diagrams for Position, Speed or Force in Chapter 5, for a better understanding.

Position Command Error (U00)

L 39025



Lower (L)

Higher (H)

Position command error [command unit]

Press ⏪ to switch between Lower (L) and Higher (H).

L 39025 ↔ H 103

Motor Speed (U01)

r 1000

- ♦ Displays the motor speed (unit: mm/s).
- ♦ Speeds in reverse operation are displayed with "-".

Position Command Speed (U02)

r 1000

- ♦ Displays the position command speed (unit: mm/s).

Speed Control Command (U03)

r 1000

- ♦ Displays the speed control command, that is, the speed of the pulse command input (unit: mm/s).

Force Command (U04)

t 100.0

- ♦ Displays the percentage of drive force command.
- ♦ When the rated force output for the drive is used, "100%" is displayed.
- ♦ Force outputs in reverse operation are displayed with "-".

Total Encoder Pulses (U05)

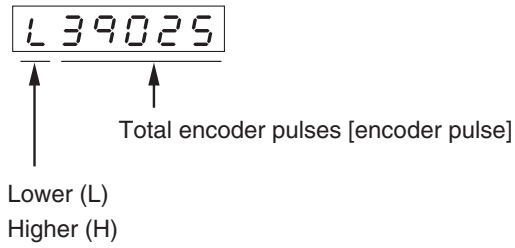

Press (◀) to switch between Lower (L) and Higher (H).



Total Command Pulses (U06)

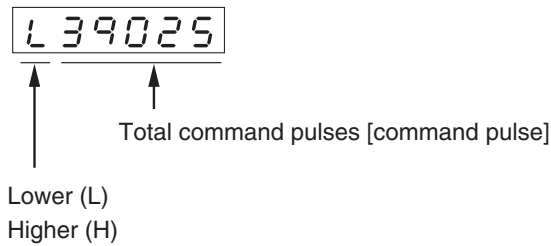

Press (◀) to switch between Lower (L) and Higher (H).



CONTROL mode (U09)

Poscnt POSITION CONTROL mode

SPdcnt SPEED CONTROL mode

tr9cnt FORCE CONTROL mode

♦ Displays which CONTROL mode is being used: position control, speed control or force control.

I/O Signal Status (U10)

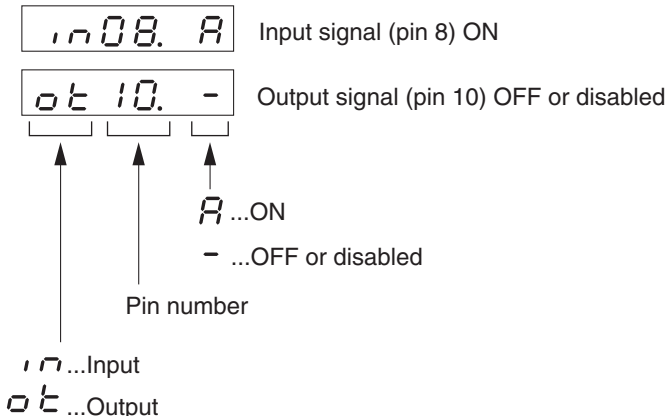

• Displays the status of the control input and output signals connected to CN1.

Switching between Input Signals and Output Signals

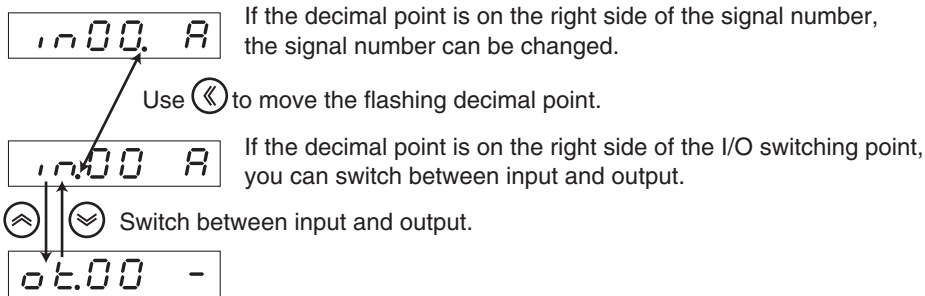

Press <Up Arrow> <Down Arrow> to select the signal you want to monitor.

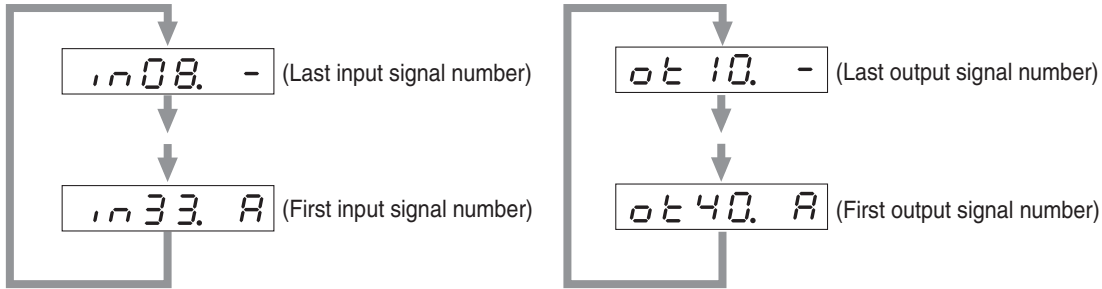

Analog Input Value (U11)

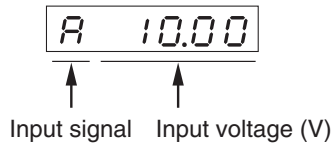

Press to select the signal you want to monitor.

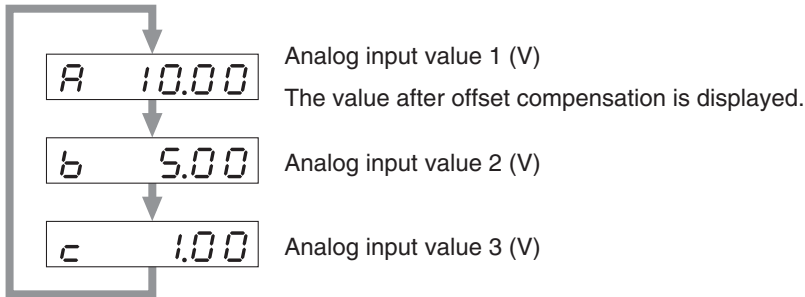

Note. Voltages exceeding +/-10 V are not displayed accurately.

Error Factor, History (U12)

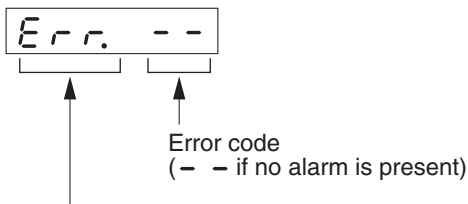

Err....Present error

E - 0....History 0 (latest history)

E 13....History 13 (oldest history)

- ♦ Up to the most recent 14 alarms, including the current one, can be viewed in the reason of error.
- ♦ The display area will flash when an alarm occurs.
- ♦ If an alarm that is recorded in the history occurs, the alarm code for the current alarm and for history 0 will be the same.

Alarm Codes and Meanings

Alarm codes	Contents	Alarm codes	Contents
11	Control power supply undervoltage	33	IO setting error
12	Overvoltage	34	Overrun limit error
13	Main power supply undervoltage	36	Parameter error
14	Overcurrent	37	Parameters destruction
15	Drive overheat	38	Drive prohibition input error
16	Overload	39	Excessive analog input
18	Regeneration overload	50	Serial Encoder communication alarm
24	Error counter overflow	51	Serial Encoder abnormal data
26	Overspeed	55	A/B Encoder or Hall sensor wiring alarm
27	Electronic gear setting error	60	Linear motor setting alarm
28	Regeneration pulse excessive frequency	61	Magnetic pole estimation error
29	Error counter overflow	87	E-STOP alarm
30	Safety input alarm	93	Wrong encoder connected

Note. The following alarms are not recorded in the history.

- 11: Control power supply undervoltage
- 13: Main power supply undervoltage
- 36: Parameter error
- 37: Parameters destruction
- 38: Drive prohibition input error
- 95: Motor non-conformity

Warning Number (U13)

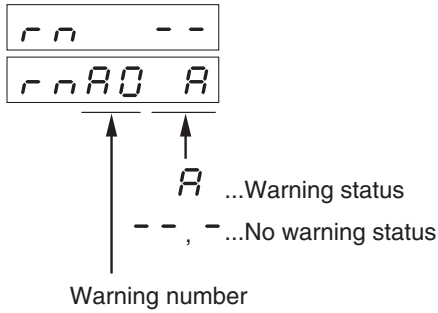

Press to display the occurrence status of each warning.

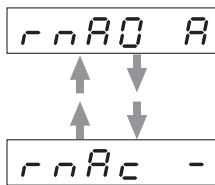

Regeneration Load Ratio (U14)



- Displays the regeneration resistance load ratio as a percentage when the detection level for the regeneration overload is 100%.

Overload Load Ratio (U15)



- Displays the overload ratio as a percentage when the rated load corresponds to 100%.

Mass Ratio (U16)



The mass ratio (%) is displayed.

Reasons for No Movement (U17)

A number is displayed to indicate the reason the motor does not move.



CONTROL mode Reason number

P...Position control t ...Force (Thrust)
S...Speed control

Number	Item	RELEVANT CONTROL mode	Description
Flashing	Alarm or warning has occurred	All	An alarm has occurred. Warning has occurred.
0	No reason	All	No reason has been detected. The motor operation should be possible.
1	Main power supply interrupted	All	The main power supply to the drive is not turned ON.
2	No RUN input	All	The operation command (RUN) is not connected to COM.
3	Drive prohibition input is enabled.	All	When Pn504 = 0 (drive prohibition input enabled): <ul style="list-style-type: none"> · The forward drive prohibition input (POT) is open and the speed command is in the forward direction. · The reverse drive prohibition input (NOT) is open and the speed command is in the reverse direction.
4	Low force limit setting	All	The currently effective force limit set value, Pn013 (No. 1 Force Limit) or Pn522 (No. 2 Force Limit), is less than 5% of the rated force.
5	Analog force limit input is enabled.	P, S	When Pn527 = 0 (analog force limit scale): <ul style="list-style-type: none"> · The forward analog force limit input is negative and the speed command is in the forward direction. · The reverse analog force limit input is positive and the speed command is in the reverse direction.
6	IPG input is enabled.	P	Pn518 = 0 (command pulse prohibition input enabled) and the IPG input is open.
7	Frequency of command pulse input is low.	P	<ul style="list-style-type: none"> · The command pulse is not input correctly. · The input selected in Pn005 is not connected correctly. · The type of input selected in Pn006 or Pn007 is not correct. The position command per control cycle is 1 pulse or less and the above are some of the possible causes.
8	ECRST input is enabled.	P	Pn517 = 0 (Error counter reset at the level) and the error counter reset input (ECRST) is connected to COM.
9	VZERO input is enabled.	S, T	Pn315 = 1 (zero speed designation enabled) and the zero speed designation input (VZERO) is open.
10	External speed command is low.	S	The analog speed command is 0.06 V or lower when the analog speed command is selected.
11	Internal speed command is 0.	S	The internal speed command is 30 mm/s or less when the internal speed command is selected.
12	Force command is low	T	The analog force command input (REF or PCL) is 5% or less of the rated force.
13	Speed limit is low	T	<ul style="list-style-type: none"> · Pn317 = 0 (speed limit with No. 4 internally set speed) and the No. 4 Internally Set Speed (Pn307) is 30 mm/s or lower. · Pn317 = 1 (speed limit with REF input) and the analog speed command input (REF) is 0.06 V or lower.
14	Other reasons	All	Reasons 1 to 13 do not apply, but the motor is moving at 20 mm/s or lower. (Low command, heavy, locked, or crashed load, faulty drive or motor, etc.)

Note: The motor may move even if a reason number other than 0 is displayed.

Display of the Number of I/O Signal Changes (U18)

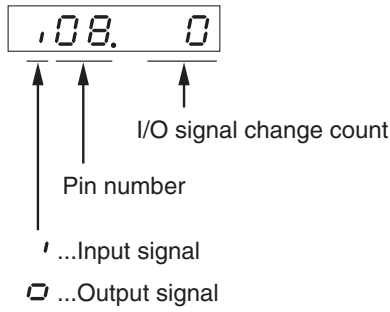

If the decimal point is on the right side of the pin number, the pin number can be changed.

Use ⏪ to move the flashing decimal point.

If the decimal point is between the pin numbers, you can switch between input and output.

Press ⏩ ⏪ to switch between input and output.



- ◆ Display the number of transitions in one input since last power-on.

Absolute Encoder Position (U21)

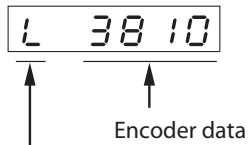

L ...Absolute Encoder position, lower (L)

H ...Absolute Encoder position, higher (H)

Press ⏩ ⏪ to switch between Lower (L) and Higher (H).



Monitor for the Number of Serial Encoder Communications Error (U22)

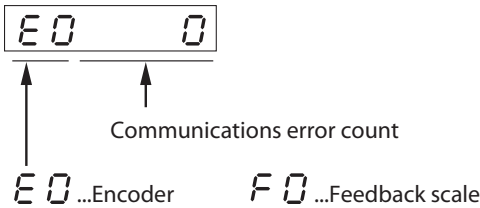

Press to switch between encoder and feedback scale.

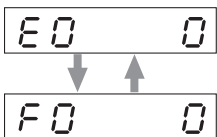

Display of Axis Numbers for Communication (U23)

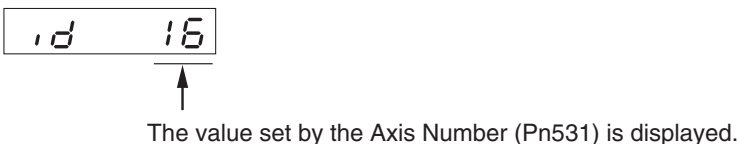

Encoder Position Error (U24)

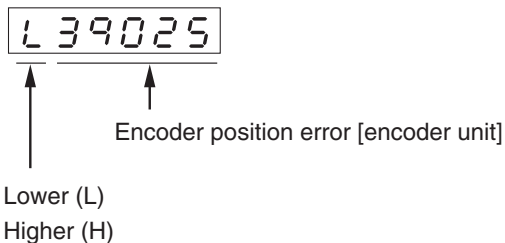

Press to switch between Lower (L) and Higher (H).



P-N Voltage (U27)

Pn 280

↑
P-N voltage [V] is displayed.

Soft Version (U28)

A-1.23

• Displays the soft version of the drive. (Display example: Ver. 1.23)

Drive Serial Number (U29)

AL0001

↑ ↑
Amplifier serial number

AL ...Amplifier serial number, lower (L) *AH* ...Amplifier serial number, higher (H)

Press ⏪ ⏩ to switch between Lower (L) and Higher (H).

Display example) When serial number is 09040001

AL0001

↓ ↑
AH0904

Accumulative Operation Time (U31)



↑ Accumulative operation time [h] is displayed.

Lower (L)
Higher (H)

Press ⏪ to switch between Lower (L) and Higher (H).



Drive Temperature (U33)



↑ Amplifier temperature [°C] is displayed.

Safety Status Temperature (U35)

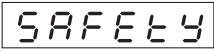

↑ SAFETy : Safety status
SrVoFF : Servo OFF
SrVon : Servo ON
ALArM : Alarm status

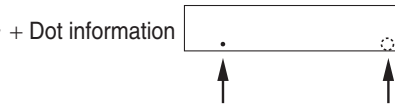

Servo ready
OFF: The dot is not lit.
ON: The dot is lit.

Flash display
Status that allows normal changes

Press ⏪ ⏩ to switch between monitors you want to display.

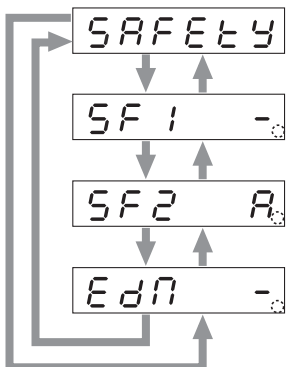

- ...Input photocoupler OFF A...Input photocoupler ON
- ...Input photocoupler OFF A...Input photocoupler ON
- ...Output photocoupler OFF A...Output photocoupler ON

Linear Motor Status Monitor (U37)

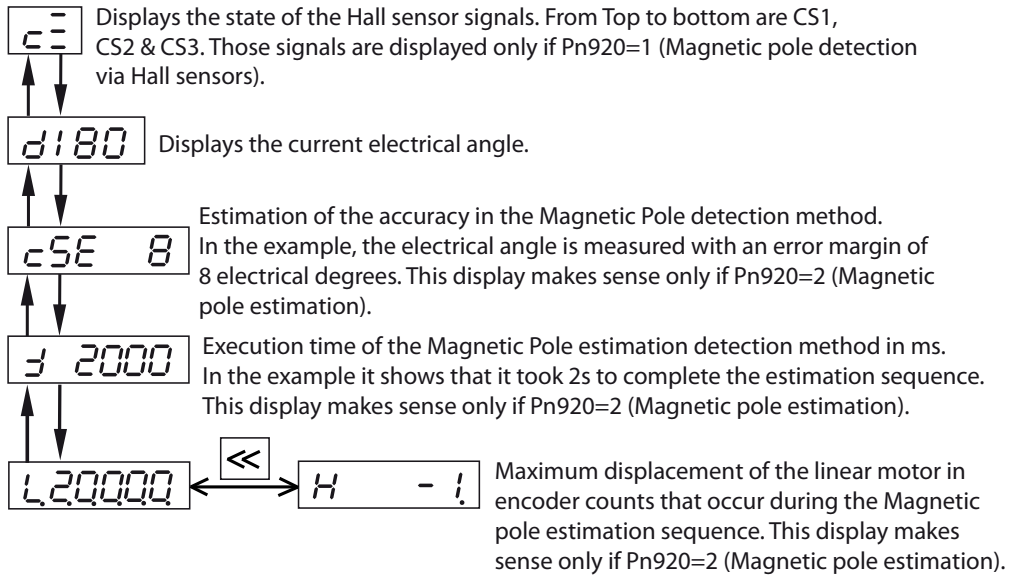

PARAMETER SETTING Mode

1. Displaying PARAMETER mode

Key operation	Display example	Explanation
		The item set for the Default Display (Pn528) is displayed.
		Press the key to display MONITOR mode.
		Press key to display PARAMETER SETTING mode.

2. Setting the parameter number

Key operation	Display example	Explanation
		Use keys to set the parameter number. <ul style="list-style-type: none"> · Press to move "." to the left and change the digit to be set. · Press to increase the value of the digit with ".". · Press to decrease the value of the digit with ".".



3. Displaying parameter set values

Key operation	Display example	Explanation
		Press the key to display the set value.

4. Changing the parameter set value

Key operation	Display example	Explanation
		Use the keys to change the value. <ul style="list-style-type: none"> · Press to move "." to the left and change the digit to be set. · Press to increase the value of the digit with ".". · Press to decrease the value of the digit with ".".
		Press the key to save the new set value. <ul style="list-style-type: none"> · To cancel the change, instead of pressing , press to return to the display in procedure 2.

5. Returning to PARAMETER SETTING mode

Key operation	Display example	Explanation
		Press the  key to return to PARAMETER SETTING mode.













Precautions for Correct Use

- ♦ Some parameters will be displayed with an "r" before the number when the display returns to the PARAMETER SETTING mode. To enable the set values that have been changed for these parameters, you must turn the power supply OFF and ON after saving the parameters to the EEPROM.
- ♦ If the Front Panel Parameter Write Selection (Pn617) is set to 1, the parameter set value is automatically written to EEPROM when changed.
- ♦ When the set value for a parameter is saved, the new setting will be used for control. Make gradual changes instead of changing the large numbers at once, when changing values for parameters that greatly affect motor operation (speed loop gain, position loop gain, etc. in particular).
- ♦ For details on parameters, refer to "Chapter 8, Parameters Details".



PARAMETER WRITE Mode

Set values changed in PARAMETER SETTING mode must be saved to EEPROM. To do so, the following operation must be performed.

1. Saving changed set values

Key operation	Display example	Explanation
	EE SET	Press the  key to display PARAMETER WRITE mode.
	EEP -.	Press the  key to enter PARAMETER WRITE mode.
	EEP --. - - - - -. StArt	Press and hold the  key for 5 seconds or longer until  is displayed. The bar indicator will increase. Writing will start. (This display will appear only momentarily.)
	Fin ish.	This indicates a normal completion. In addition to this display, either  or  may be displayed. If  is displayed, writing has been completed normally, but some of the changed parameters will be valid only after the power supply has been turned OFF and ON again. Turn OFF the drive power supply and then turn it ON again.  will be displayed if there is a write error. Write the data again.

2. Returning to PARAMETER WRITE mode

Key operation	Display example	Explanation
	EE SET	Press the  key to return to PARAMETER WRITE mode.









Precautions for Correct Use

- ♦ If a write error occurs, write the data again. If write errors continue to occur, there may be a fault in the drive.
- ♦ Do not turn OFF the power supply while writing to EEPROM. Incorrect data may be written if the power supply is turned OFF. If the power supply is turned OFF, perform the settings again for all parameters, and write the data again.

AUXILIARY FUNCTION Mode

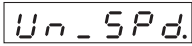
AUXILIARY FUNCTION mode includes the alarm clear, analog input automatic offset adjustment, jog operation, parameter initialization, and front panel lock/release.

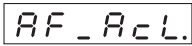





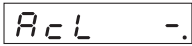

Displaying AUXILIARY FUNCTION mode

Key operation	Display example	Explanation
		The item set for the Default Display (Pn528) is displayed.
		Press the  key to display MONITOR mode.
		Press the  key 3 times to display AUXILIARY FUNCTION mode.

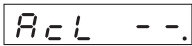

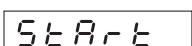
Alarm Clear

This releases the alarm generation status.
Some alarms cannot be released. Refer to "Alarm List" (P.11-6) for details.

1. Execute alarm clear

Key operation	Display example	Explanation
		Press the  key to enter ALARM CLEAR mode.
	  	Press and hold the  key for 5 seconds or longer until  is displayed. The bar indicator will increase. Alarm clear will start.
		This indicates a normal completion.  will be displayed if the alarm could not be cleared. Reset the power supply to clear the error.

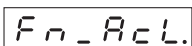
2. Returning to AUXILIARY FUNCTION mode display







Key operation	Display example	Explanation
		Press the  key to return to AUXILIARY FUNCTION mode.

Analog Input Automatic Offset Adjustment



This performs automatic adjustment on the Offset Values (Pn422, Pn425 and Pn428) of Analog Inputs 1 to 3 (AI1 to AI3).

Do not perform this operation if a position loop has been configured with the host system.

1. Execute automatic offset adjustment

Key operation	Display example	Explanation
	Fn_of 1. or Fn_of 2. or Fn_of 3.	Press the  key to display the ANALOG INPUT AUTOMATIC OFFSET ADJUSTMENT mode from the alarm clear display in the AUXILIARY FUNCTION mode.
	of 1 -. or of 2 -. or of 3 -.	Press the  key to enter the AUTOMATIC OFFSET ADJUSTMENT mode of the analog input number to be set.
	of 1 --. or of 2 --. or of 3 --. -----. StArt	Press and hold the  key for 5 seconds or longer until StArt is displayed. The bar indicator will increase. Automatic offset adjustment will start.
	Fin,sh.	This indicates a normal completion. Error will be displayed if the automatic offset adjustment could not be performed. Set a valid CONTROL mode or make the setting so that the offset value does not exceed the range for the Speed Command Offset Adjustment, and then execute the procedure again.

2. Returning to AUXILIARY FUNCTION mode display

Key operation	Display example	Explanation
	Fn_of 1. or Fn_of 2. or Fn_of 3.	Press the  key to return to AUXILIARY FUNCTION mode.



Precautions for Correct Use

- ♦ Automatic offset adjustment function cannot be performed in POSITION CONTROL mode.
- ♦ Data is not written to the EEPROM simply by performing automatic offset adjustment. The data must be written to the EEPROM for the results to be saved.

Jog Operation

You can perform a trial operation of the motor with no load without wiring the control I/O connector (CN1).



1. Prepare for a jog operation

Key operation	Display example	Explanation
	Fn_JoG.	Press the key to display the JOG OPERATION mode from the alarm clear display in AUXILIARY FUNCTION mode.
	JoG -.	Press the key to enter JOG OPERATION mode.
	JoG --. -----. rEAdY.	Press and hold the key for 5 seconds or longer until StArT is displayed. The bar indicator will increase. This completes preparations for jog operation. Error will be displayed if the servo is not ready.
	rEAdY. r.EAdY SrU_on	Press and hold the key for 5 seconds or longer until StArT is displayed. The decimal point will move to the left. The Servo will turn ON.

2. Execute jog operation

Key operation	Display example	Explanation
	SrU_on	Forward direction operation will be performed while the key is pressed, and reverse direction operation will be performed while the key is pressed. The motor will stop when the key is released. The movement speed at this time will be the speed set for the Jog Speed (Pn604). Error will be displayed if the servo is not ready.

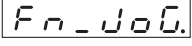
3. Returning to AUXILIARY FUNCTION mode display

Key operation	Display example	Explanation
		Press the  key to return to AUXILIARY FUNCTION mode. The servo lock will be released and the servo will be unlocked.





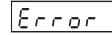

Precautions for Correct Use

- When performing a jog operation remove the control I/O connector (CN1).
- When performing a jog operation, set the parameter related to gains to an appropriate value to avoid any troubles, such as vibration. Set the Mass Ratio (Pn004) to an appropriate value.
- The motor operates in the SPEED CONTROL mode during a jog operation. Set each of the various settings so that the motor operates correctly for speed control.
- If the operation command (RUN) is turned ON during a jog operation,  will be displayed, and the jog operation will be cancelled and a normal operation through an external command will be performed.

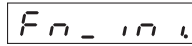

Parameter Initialization

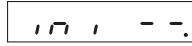
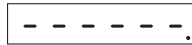
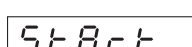
This initializes the selected parameter.

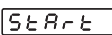
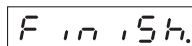
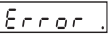
1. Execute the initialization of the parameter.

Key operation	Display example	Explanation
		Press the  key to enter PARAMETER INITIALIZATION mode.
	  	Press and hold the  key for 5 seconds or longer until  is displayed. The bar indicator will increase. The initialization of the selected parameter will start.
		This indicates a normal completion.  will be displayed if the parameter could not be initialized. Turn OFF the drive power supply and then execute again.

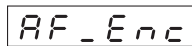
2. Returning to AUXILIARY FUNCTION mode display

Key operation	Display example	Explanation
		Press the  key to return to AUXILIARY FUNCTION mode.







Precautions for Correct Use

- If alarm display No. 11 (power supply undervoltage), 36 (parameter error) or 37 (parameter destruction) is displayed, the parameter cannot be initialized.



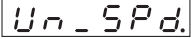







Front Panel Lock

This locks the front panel.



1. Displaying PARAMETER mode

Key operation	Display example	Explanation
		Press the  key to display MONITOR mode.
		Press  key to display PARAMETER SETTING mode.















2. Setting the parameter number

Key operation	Display example	Explanation
  		Use the    keys to set to Pn535. <ul style="list-style-type: none"> · Press  to move "." to the left and change the digit to be set. · Press  to increase the value of the digit with ".". · Press  to decrease the value of the digit with ".".



3. Displaying parameter set values

Key operation	Display example	Explanation
		Press the  key to display the set value.





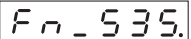





4. Changing the parameter set value

Key operation	Display example	Explanation
  		Use the    keys to change the value. <ul style="list-style-type: none"> · Press  to move "." to the left and change the digit to be set. · Press  to increase the value of the digit with ".". · Press  to decrease the value of the digit with ".".
		Press the  key to save the new set value. <ul style="list-style-type: none"> · To cancel the change, instead of pressing , press  to return to the display in procedure 2.



5. Returning to PARAMETER SETTING mode

Key operation	Display example	Explanation
		Press the  key to return to PARAMETER SETTING mode.

6. Saving changed set values

Key operation	Display example	Explanation
	EE SET	Press the  key to display PARAMETER WRITE mode.
	EEP -.	Press the  key to enter PARAMETER WRITE mode.
	EEP --. -----. StArt	Press and hold the  key for 5 seconds or longer until  is displayed. The bar indicator will increase. Writing will start. (This display will appear only momentarily.)
	Finish.	This indicates a normal completion. In addition to this display, either  or  may be displayed. If  is displayed, writing has been completed normally, but some of the changed parameters will be valid only after the power supply has been turned OFF and ON again. Turn OFF the drive power supply and then turn it ON again.  will be displayed if there is a write error. Write the data again.

7. Returning to PARAMETER WRITE mode

Key operation	Display example	Explanation
	EE SET	Press the  key to return to PARAMETER WRITE mode.

8. Restart the power supply to the drive.









Precautions for Correct Use

- The items that are limited depend on the mode.
- If the Front Panel Parameter Write Selection (Pn617) is set to 1, the parameter set value is automatically written to EEPROM when changed.
- Refer to the Front Key Protection Setting (Pn535) in "8-6 Extended Parameters" (P.8-45) for details on the front panel lock function.



Front Panel Lock Release

This releases the front panel lock.

1. Release the front panel lock

Key operation	Display example	Explanation
	<code>Fn_UnL</code>	Press the  key to display the FRONT PANEL LOCK mode from the alarm reset display in AUXILIARY FUNCTION mode.
	<code>unL -.</code>	Press the  key to enter FRONT PANEL LOCK mode.
	<code>unL --.</code> <code>-----.</code> <code>StArt</code>	Press and hold the  key for 5 seconds or longer until <code>StArt</code> is displayed. The bar indicator will increase. The front panel lock will be released.
	<code>Finish.</code>	This indicates a normal completion. <code>Error.</code> will be displayed if the front panel lock is not released. Turn OFF the drive power supply and then execute again.

2. Returning to AUXILIARY FUNCTION mode display

Key operation	Display example	Explanation
	<code>Fn_EnC</code>	Press the  key to return to AUXILIARY FUNCTION mode.

9-5 Trial Operation

When you have finished installation, wiring, and switch settings and have confirmed that status is normal after turning ON the power supply, perform trial operation. The main purpose of trial operation is to confirm that the servo system is electrically correct.

If an error occurs during the trial operation, refer to "Chapter 11, Error and Maintenance" to eliminate the cause. Then check for safety, and then retry the trial operation.

Preparation for Trial Operation

Inspections before Trial Operation

Check the following items.

Wiring

- ♦ Make sure that there is no error (especially the power supply input and motor output).
- ♦ Make sure that there are no short-circuits. (Check the ground for short circuits as well.)
- ♦ Make sure that there are no loose connections.

Power Supply Voltage

- ♦ Make sure that the voltage corresponds to the rated voltage.

Motor Installation

- ♦ Make sure that it is securely installed.

Brake Released

- ♦ Make sure that the brake, if used, has been released.

Motor and Encoder Setup

- ♦ Make sure the motor and Encoder are properly configured.

Trial Operation in POSITION CONTROL Mode

1. Connect connector CN1.
2. Input power supply (12 to 24 VDC) for the control signals (+24 VIN, COM).
3. Turn ON the power supply to the drive.
4. Confirm that the parameters are set to the standard set values and the motor and encoder have been properly configured.
5. Set to the output from the host device that agrees using the COMMAND PULSE INPUT mode (Pn007).
6. Write the parameters to EEPROM and then turn OFF the power supply and turn it ON again.
7. Connect the operation command input (RUN: CN1 pin 29) to COM (CN1 pin 41). Servo ON status will be entered and the motor will be activated.
8. If there are no Hall sensors installed in the motor, on the first RUN, the Magnetic Pole Estimation sequence is performed. Confirm that the sequence finishes successfully.
9. Input a low-frequency pulse signal from the host device to start low-speed operation.
10. Check the motor movement speed in MONITOR mode.
Check to see if the motor is moving at the set speed and to see if the motor stops when the command (pulses) are stopped.

Trial Operation in SPEED CONTROL Mode

1. Connect connector CN1.
2. Input power supply (12 to 24 VDC) for the control signals (+24 VIN, COM).
3. Turn ON the power supply to the drive.
4. Confirm that the parameters are set to the standard set values and the motor and encoder have been properly configured.
5. Connect the operation command input (RUN: CN1 pin 29) to COM (CN1 pin 41). Servo ON status will be entered and the motor will be activated.
6. If there are no Hall sensors installed in the motor, on the first RUN, the Magnetic Pole Estimation sequence is performed. Confirm that the sequence finishes successfully.
7. Close the zero speed designation input (VZERO) and gradually increase the DC voltage between the speed command input REF (CN1 pin 14) and AGND1 (CN1 pin 15) from 0 V. Check to see if the motor moves.
8. Check the motor movement speed in MONITOR mode.
Check to see if the motor is moving at the set speed and to see if the motor stops when the command (pulses) are stopped.
Use the following parameters to change the motor movement speed or direction.
 - ♦ Pn302: Speed Command Scale
 - Pn303: Command Speed Movement Direction Switching

Trial Operation in FORCE CONTROL Mode

1. Connect connector CN1.
2. Input power supply (12 to 24 VDC) for the control signals (+24 VIN, COM).
3. Turn ON the power supply to the drive.
4. Confirm that the parameters are set to the standard set values and the motor and encoder have been properly configured.
5. Set a low speed in the No. 4 Internally Set Speed (Pn307).
6. Connect the operation command input (RUN: CN1 pin 29) to COM (CN1 pin 41). Servo ON status will be entered and the motor will be activated.
7. If there are no Hall sensors installed in the motor, on the first RUN, the Magnetic Pole Estimation sequence is performed. Confirm that the sequence finishes successfully.
8. Apply a positive or negative DC voltage between the force command input FREF1 (CN1 pin 14) and AGND1 (CN1 pin 15). Check to see if the motor moves according to the direction (forward/reverse) set in Pn307.
Use the following parameters to change the amount of the force, direction of the force, or speed limit value for the command voltage.
 - ♦ Pn307: No. 4 Internally Set Speed (default set value: 50 mm/s)
 - ♦ Pn319: Force Command Scale
 - Pn320: Force Output Direction Switching

10

Adjustment Functions

This chapter explains the functions, setting methods and items to note regarding various gain adjustments.

10-1 Gain Adjustment	10-2
Purpose of the Gain Adjustment.....	10-2
Gain Adjustment Methods.....	10-2
Gain Adjustment Procedure.....	10-3
10-2 Realtime Autotuning	10-4
Setting Realtime Autotuning	10-5
Setting Machine Rigidity	10-6
Related Parameters.....	10-11
10-3 Manual Tuning	10-12
Basic Settings	10-12

10-1 Gain Adjustment

Accurax G5-Linear Servo Drives provide the realtime autotuning function. With these functions, gain adjustments can be made easily even by those who use a servo system for the first time. If you cannot obtain desired responsiveness with autotuning, use manual tuning.

Purpose of the Gain Adjustment

The drive must operate the motor in response to commands from the host system with minimal time delay and maximum reliability. The gain is adjusted to bring the actual operation of the motor as close as possible to the operations specified by the commands, and to maximize the performance of the machine.

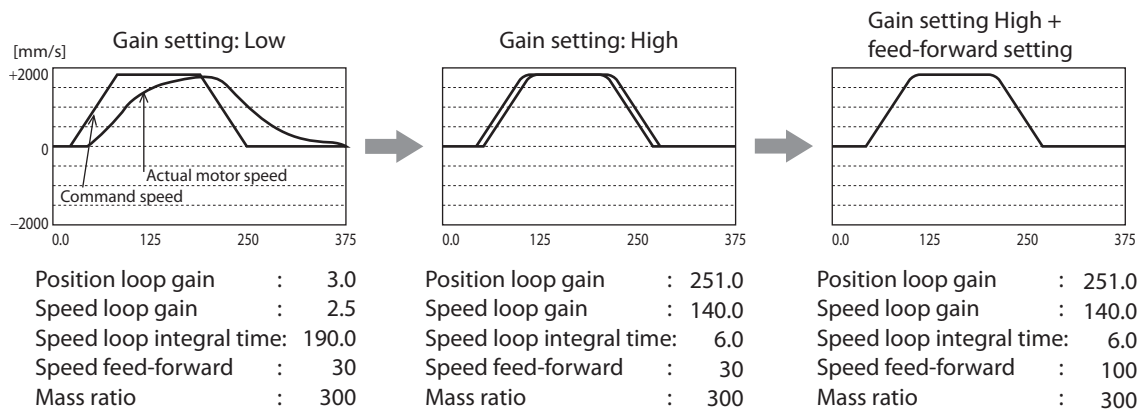

Gain Adjustment Methods

Function		Explanation	Reference page
Automatic adjustment	Realtime autotuning	Realtime autotuning estimates the load mass of the machine in realtime and automatically sets the optimal gain according to the estimated load mass.	P.10-4
Manual adjustment	Manual tuning	Manual adjustment is performed if autotuning cannot be executed due to restrictions on the CONTROL mode or load conditions or if ensuring the maximum responsiveness to match each load is required.	P.10-12
	Basic procedure	POSITION CONTROL mode adjustment	P.10-13
		SPEED CONTROL mode adjustment	P.10-14
FORCE CONTROL mode adjustment		P.10-19	

Note 1. Take sufficient care for safety.

Note 2. If vibration occurs (unusual noise or vibration), immediately turn OFF the power supply or let the servo OFF status occur.

Gain Adjustment Procedure

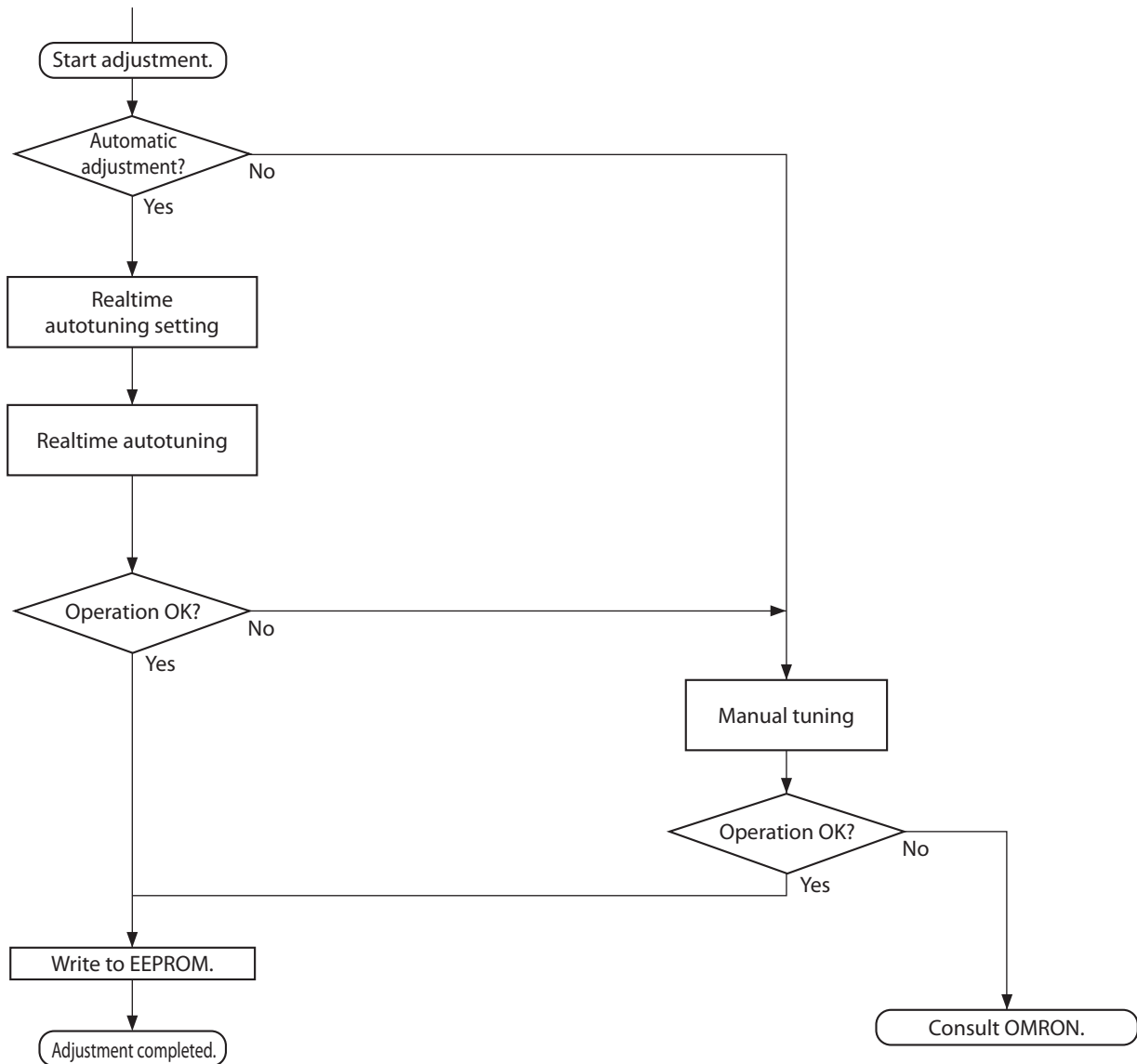

Gain Adjustment and Machine Rigidity

To improve machine rigidity:

- Install the machine on a secure base so that it does not cause any play.
 - Use linear guides that have a high rigidity, and that are designed for servo systems.
- The specific vibration (resonance frequency) of the mechanical system has a large impact on the gain adjustment of the servo. The servo system responsiveness cannot be set high for machines with a low resonance frequency (low machine rigidity).

10-2 Realtime Autotuning

Realtime autotuning estimates the load mass of the machine in realtime and operates the machine by automatically setting the gain according to the estimated load mass. At the same time, it can lower the resonance and vibration if operated with the adaptive filter enabled. Realtime autotuning is enabled for any control to adjust the speed loop PI control.

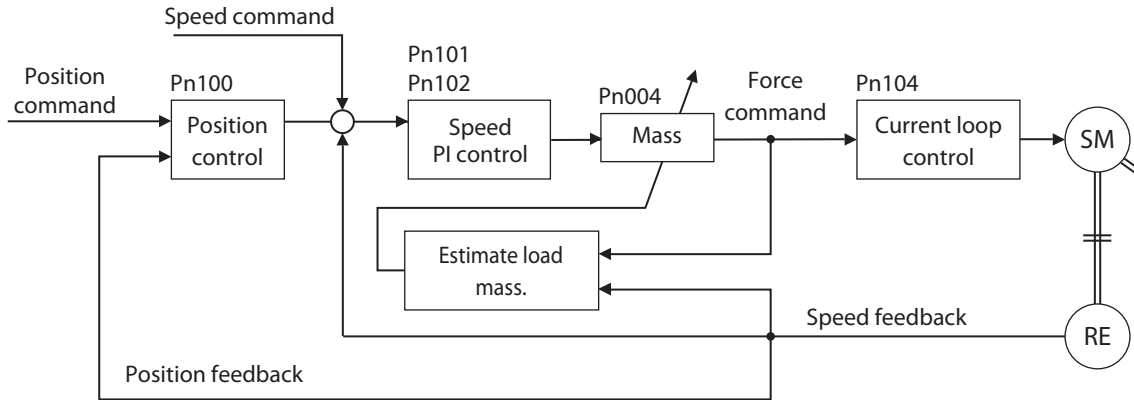

Precautions for Correct Use

- Realtime autotuning may not function properly under the conditions described in the following table. In such cases, use manual tuning.

	Conditions under which realtime autotuning does not operate properly
Load mass	<ul style="list-style-type: none"> If the load mass is small or large compared with the motor mass. (less than 3 times, more than 20 times, or more than the applicable load mass ratio) If the load mass changes quickly. (in less than 10 s)
Load	<ul style="list-style-type: none"> If the machine rigidity is extremely low. If there is backlash or play in the system.
Operation pattern	<ul style="list-style-type: none"> If the speed is continuously run at a low speed below 100 mm/s. If the acceleration/deceleration gradually changes at less than 2,000 mm/s in 1 s. If the acceleration/deceleration force is too small compared with the unbalanced load and the viscous friction force. If a speed of 100 mm/s or an acceleration/deceleration of 2,000 mm/s² does not continue for at least 50 ms.

- With realtime autotuning, each parameter is fixed to the value in the machine rigidity table at the time the machine rigidity is set. By estimating the load mass from the operation pattern, the operation coefficient for the speed loop gain and the integration time constant are altered. Doing this for each pattern can cause vibration, so the estimation value is set conservatively.

Setting Realtime Autotuning

1. When setting realtime autotuning, turn the servo OFF.

2. Set REALTIME AUTOTUNING mode Selection (Pn002) depending on the load.

When the value is set to 3 to 5, the response is fast for a change in mass during operation. Operation, however, may be unstable depending on the operating pattern. Normally, set the parameter to 1.

Use a setting of 3 to 5 when the vertical axis is used.

Gain switching function is enabled for set values 2 to 6.

Set value	Realtime autotuning	Explanation
0	Disabled	Realtime autotuning is disabled. Tuning has to be made manually.
1	Focused on stability	The automatic adjustments are: - Mass calculation. - Rigidity setting.
2	Focused on positioning	The automatic adjustments are: - Mass calculation. - Rigidity setting. - Gain switching enabled (Pn115=10).
3	Vertical axis mode	The automatic adjustments are: - Mass calculation. - Rigidity setting. - Gain switching enabled (Pn115=10). - Unbalanced load compensation.
4	Friction compensation mode	The automatic adjustments are: - Mass calculation. - Rigidity setting. - Gain switching enabled (Pn115=10). - Unbalanced load compensation. - Friction compensation.
5	Tool mode	Used In combination with the Software tool. The drive detects the adjustment values but they must be applied manually from the tool.
6	Customized mode	Used when freely combining Realtime Autotuning mode and Applicable Filter mode settings (Pn632).

Setting Machine Rigidity

- 1. Set the Realtime Autotuning Machine Rigidity Selection (Pn003) according to the application requirements.**
Start from the lower machine rigidity number and check the operation.
- 2. Turn the servo ON and operate the machine with a normal pattern.**
To increase responsiveness, increase the machine rigidity number, and check the response. If vibration occurs, enable the adaptive filter and operate. If already enabled, adjust by lowering the machine rigidity number.
- 3. If there are no issues with the operation, turn the servo OFF and set REALTIME AUTOTUNING mode Selection (Pn002) to 0 (disabled).**
In this case, the adaptive filter can remain enabled. To disable the adaptive filter, read the frequency from the adaptive filter table number display, and set to notch filter 1 frequency.



Precautions for Correct Use

- ♦ Unusual noise or vibration may occur until the load mass is estimated or the adaptive filter stabilizes after startup, immediately after the first servo ON, or when the Realtime Autotuning Machine Rigidity Selection (Pn003) is increased. This is not an error if it disappears right away. If the unusual noise or vibration, however, continues for 3 or more reciprocating operations, take the following measures in any order you can.
 - Write the parameters used during normal operation to the EEPROM.
 - Lower the Realtime Autotuning Machine Rigidity Selection (Pn003).
 - Manually set the notch filter.
 - ♦ Once unusual noise or vibration occurs, Mass Ratio (Pn004), Force Command Value Offset (Pn607), Forward Direction Force Offset (Pn608), and Reverse Direction Force Offset (Pn609) may have changed to an extreme value. In this case, also take the measures described above.
 - ♦ Out of the results of realtime autotuning, the Mass Ratio (Pn004), Force Command Value Offset (Pn607), Forward Direction Force Offset (Pn608) and Reverse Direction Force Offset (Pn609) are automatically saved to the EEPROM every 30 minutes. Realtime autotuning will use this saved data as the default setting when the power supply is turned OFF and turned ON again.
 - ♦ The parameter will automatically be set based on the Realtime Autotuning Machine Rigidity Setting (Pn003) if realtime autotuning is enabled.
-

Realtime Autotuning (RTAT) Parameter Table

Parameter number	Parameter name	AT Machine Rigidity Setting (Pn003)							
		0	1	2	3	4	5	6	7
Pn004	Mass Ratio	Estimated load mass ratio							
Pn100	Position Loop Gain	20	25	30	40	45	55	75	95
Pn101	Speed Loop Gain	15	20	25	30	35	45	60	75
Pn102	Speed Loop Integral Time Constant	3700	2800	2200	1900	1600	1200	900	700
Pn103	Speed Feedback Filter Time Constant	0	0	0	0	0	0	0	0
Pn104	Force Command Filter Time Constant 1 ^{*1}	1500	1100	900	800	600	500	400	300
Pn105	Position Loop Gain 2	25	30	40	45	55	70	95	120
Pn106	Speed Loop Gain 2	15	20	25	30	35	45	60	75
Pn107	Speed Loop Integral Time Constant 2	10000	10000	10000	10000	10000	10000	10000	10000
Pn108	Speed Feedback Filter Time Constant 2	0	0	0	0	0	0	0	0
Pn109	Force Command Filter Time Constant 2 ^{*1}	1500	1100	900	800	600	500	400	300
Pn110	Speed Feed-forward Amount	300	300	300	300	300	300	300	300
Pn111	Speed Feed-forward Command Filter	50	50	50	50	50	50	50	50
Pn112	Force Feed-forward Amount	0	0	0	0	0	0	0	0
Pn113	Force Feed-forward Command Filter	0	0	0	0	0	0	0	0
Pn114	GAIN SWITCHING INPUT OPERATING mode Selection	1	1	1	1	1	1	1	1
Pn115	SWITCHING mode in Position Control	For Pn002= 2,3,4 or 5: 10 For Pn002= 0 or 1: 0							
Pn116	Gain Switching Delay Time in Position Control	30	30	30	30	30	30	30	30
Pn117	Gain Switching Level in Position Control	50	50	50	50	50	50	50	50
Pn118	Gain Switching Hysteresis in Position Control	33	33	33	33	33	33	33	33
Pn119	Position Gain Switching Time	33	33	33	33	33	33	33	33
Pn120	SWITCHING mode in Speed Control	0	0	0	0	0	0	0	0
Pn121	Gain Switching Delay Time in Speed Control	0	0	0	0	0	0	0	0
Pn122	Gain Switching Level in Speed Control	0	0	0	0	0	0	0	0
Pn123	Gain Switching Hysteresis in Speed Control	0	0	0	0	0	0	0	0
Pn124	SWITCHING mode in Force Control	0	0	0	0	0	0	0	0
Pn125	Gain Switching Delay Time in Force Control	0	0	0	0	0	0	0	0
Pn126	Gain Switching Level in Force Control	0	0	0	0	0	0	0	0
Pn127	Gain Switching Hysteresis in Force Control	0	0	0	0	0	0	0	0
Pn605	Gain 3 Effective Time	0	0	0	0	0	0	0	0
Pn606	Gain 3 Ratio Setting	100	100	100	100	100	100	100	100
Pn607	Force Command Value Offset	Estimated if Pn002=3,4 or 5							
Pn608	Forward Direction Force Offset	Estimated If Pn002= 4 or 5							
Pn609	Reverse Direction Force Offset	Estimated if Pn002= 4 or 5							
Pn610.0, Pn610.3	Function Expansion Setting	0	0	0	0	0	0	0	0
Pn611	Electric Current Response Setting	100	100	100	100	100	100	100	100
Pn613	Mass Ratio 2	0	0	0	0	0	0	0	0
Pn623	Disturbance Force Compensation Gain	0	0	0	0	0	0	0	0
Pn624	Disturbance Observer Filter Setting	0	0	0	0	0	0	0	0

*1. This is limited at the minimum value of 10 if a 17-bit absolute encoder is used.

Parameter number	Parameter name	AT Machine Rigidity Setting (Pn003)							
		8	9	10	11	12	13	14	15
Pn004	Mass Ratio	Estimated load mass ratio							
Pn100	Position Loop Gain	115	140	175	320	390	480	630	720
Pn101	Speed Loop Gain	90	110	140	180	220	270	350	400
Pn102	Speed Loop Integral Time Constant	600	500	400	310	250	210	160	140
Pn103	Speed Feedback Filter Time Constant	0	0	0	0	0	0	0	0
Pn104	Force Command Filter Time Constant 1*1	300	200	200	126	103	84	65	57
Pn105	Position Loop Gain 2	140	175	220	380	460	570	730	840
Pn106	Speed Loop Gain 2	90	110	140	180	220	270	350	400
Pn107	Speed Loop Integral Time Constant 2	10000	10000	10000	10000	10000	10000	10000	10000
Pn108	Speed Feedback Filter Time Constant 2	0	0	0	0	0	0	0	0
Pn109	Force Command Filter Time Constant 2*1	300	200	200	126	103	84	65	57
Pn110	Speed Feed-forward Amount	300	300	300	300	300	300	300	300
Pn111	Speed Feed-forward Command Filter	50	50	50	50	50	50	50	50
Pn112	Force Feed-forward Amount	0	0	0	0	0	0	0	0
Pn113	Force Feed-forward Command Filter	0	0	0	0	0	0	0	0
Pn114	GAIN SWITCHING INPUT OPERATING mode Selection	1	1	1	1	1	1	1	1
Pn115	SWITCHING mode in Position Control	For Pn002= 2,3,4 or 5: 10 For Pn002= 0 or 1: 0							
Pn116	Gain Switching Delay Time in Position Control	30	30	30	30	30	30	30	30
Pn117	Gain Switching Level in Position Control	50	50	50	50	50	50	50	50
Pn118	Gain Switching Hysteresis in Position Control	33	33	33	33	33	33	33	33
Pn119	Position Gain Switching Time	33	33	33	33	33	33	33	33
Pn120	SWITCHING mode in Speed Control	0	0	0	0	0	0	0	0
Pn121	Gain Switching Delay Time in Speed Control	0	0	0	0	0	0	0	0
Pn122	Gain Switching Level in Speed Control	0	0	0	0	0	0	0	0
Pn123	Gain Switching Hysteresis in Speed Control	0	0	0	0	0	0	0	0
Pn124	SWITCHING mode in Force Control	0	0	0	0	0	0	0	0
Pn125	Gain Switching Delay Time in Force Control	0	0	0	0	0	0	0	0
Pn126	Gain Switching Level in Force Control	0	0	0	0	0	0	0	0
Pn127	Gain Switching Hysteresis in Force Control	0	0	0	0	0	0	0	0
Pn605	Gain 3 Effective Time	0	0	0	0	0	0	0	0
Pn606	Gain 3 Ratio Setting	100	100	100	100	100	100	100	100
Pn607	Force Command Value Offset	Estimated if Pn002=3,4 or 5							
Pn608	Forward Direction Force Offset	Estimated If Pn002= 4 or 5							
Pn609	Reverse Direction Force Offset	Estimated if Pn002= 4 or 5							
Pn610.0, Pn610.3	Function Expansion Setting	0	0	0	0	0	0	0	0
Pn611	Electric Current Response Setting	100	100	100	100	100	100	100	100
Pn613	Mass Ratio 2	0	0	0	0	0	0	0	0
Pn623	Disturbance Force Compensation Gain	0	0	0	0	0	0	0	0
Pn624	Disturbance Observer Filter Setting	0	0	0	0	0	0	0	0

*1. This is limited at the minimum value of 10 if a 17-bit absolute encoder is used.

Parameter number	Parameter name	AT Machine Rigidity Setting (Pn003)							
		16	17	18	19	20	21	22	23
Pn004	Mass Ratio	Estimated load mass ratio							
Pn100	Position Loop Gain	900	1080	1350	1620	2060	2510	3050	3770
Pn101	Speed Loop Gain	500	600	750	900	1150	1400	1700	2100
Pn102	Speed Loop Integral Time Constant	120	110	90	80	70	60	50	40
Pn103	Speed Feedback Filter Time Constant	0	0	0	0	0	0	0	0
Pn104	Force Command Filter Time Constant 1 ^{*1}	45	38	30	25	20	16	13	11
Pn105	Position Loop Gain 2	1050	1260	1570	1880	2410	2930	3560	4400
Pn106	Speed Loop Gain 2	500	600	750	900	1150	1400	1700	2100
Pn107	Speed Loop Integral Time Constant 2	10000	10000	10000	10000	10000	10000	10000	10000
Pn108	Speed Feedback Filter Time Constant 2	0	0	0	0	0	0	0	0
Pn109	Force Command Filter Time Constant 2 ^{*1}	45	38	30	25	20	16	13	11
Pn110	Speed Feed-forward Amount	300	300	300	300	300	300	300	300
Pn111	Speed Feed-forward Command Filter	50	50	50	50	50	50	50	50
Pn112	Force Feed-forward Amount	0	0	0	0	0	0	0	0
Pn113	Force Feed-forward Command Filter	0	0	0	0	0	0	0	0
Pn114	GAIN SWITCHING INPUT OPERATING mode Selection	1	1	1	1	1	1	1	1
Pn115	SWITCHING mode in Position Control	For Pn002= 2,3,4 or 5: 10 For Pn002= 0 or 1: 0							
Pn116	Gain Switching Delay Time in Position Control	30	30	30	30	30	30	30	30
Pn117	Gain Switching Level in Position Control	50	50	50	50	50	50	50	50
Pn118	Gain Switching Hysteresis in Position Control	33	33	33	33	33	33	33	33
Pn119	Position Gain Switching Time	33	33	33	33	33	33	33	33
Pn120	SWITCHING mode in Speed Control	0	0	0	0	0	0	0	0
Pn121	Gain Switching Delay Time in Speed Control	0	0	0	0	0	0	0	0
Pn122	Gain Switching Level in Speed Control	0	0	0	0	0	0	0	0
Pn123	Gain Switching Hysteresis in Speed Control	0	0	0	0	0	0	0	0
Pn124	SWITCHING mode in Force Control	0	0	0	0	0	0	0	0
Pn125	Gain Switching Delay Time in Force Control	0	0	0	0	0	0	0	0
Pn126	Gain Switching Level in Force Control	0	0	0	0	0	0	0	0
Pn127	Gain Switching Hysteresis in Force Control	0	0	0	0	0	0	0	0
Pn605	Gain 3 Effective Time	0	0	0	0	0	0	0	0
Pn606	Gain 3 Ratio Setting	100	100	100	100	100	100	100	100
Pn607	Force Command Value Offset	Estimated if Pn002=3,4 or 5							
Pn608	Forward Direction Force Offset	Estimated If Pn002= 4 or 5							
Pn609	Reverse Direction Force Offset	Estimated if Pn002= 4 or 5							
Pn610.0, Pn610.3	Function Expansion Setting	0	0	0	0	0	0	0	0
Pn611	Electric Current Response Setting	100	100	100	100	100	100	100	100
Pn613	Mass Ratio 2	0	0	0	0	0	0	0	0
Pn623	Disturbance Force Compensation Gain	0	0	0	0	0	0	0	0
Pn624	Disturbance Observer Filter Setting	0	0	0	0	0	0	0	0

*1. This is limited at the minimum value of 10 if a 17-bit absolute encoder is used.

Parameter number	Parameter name	AT Machine Rigidity Setting (Pn003)							
		24	25	26	27	28	29	30	31
Pn004	Mass Ratio	Estimated load mass ratio							
Pn100	Position Loop Gain	4490	5000	5600	6100	6600	7200	8100	9000
Pn101	Speed Loop Gain	2500	2800	3100	3400	3700	4000	4500	5000
Pn102	Speed Loop Integral Time Constant	40	35	30	30	25	25	20	20
Pn103	Speed Feedback Filter Time Constant	0	0	0	0	0	0	0	0
Pn104	Force Command Filter Time Constant 1*1	9	8	7	7	6	6	5	5
Pn105	Position Loop Gain 2	5240	5900	6500	7100	7700	8400	9400	10500
Pn106	Speed Loop Gain 2	2500	2800	3100	3400	3700	4000	4500	5000
Pn107	Speed Loop Integral Time Constant 2	10000	10000	10000	10000	10000	10000	10000	10000
Pn108	Speed Feedback Filter Time Constant 2	0	0	0	0	0	0	0	0
Pn109	Force Command Filter Time Constant 2*1	9	8	7	7	6	6	5	5
Pn110	Speed Feed-forward Amount	300	300	300	300	300	300	300	300
Pn111	Speed Feed-forward Command Filter	50	50	50	50	50	50	50	50
Pn112	Force Feed-forward Amount	0	0	0	0	0	0	0	0
Pn113	Force Feed-forward Command Filter	0	0	0	0	0	0	0	0
Pn114	GAIN SWITCHING INPUT OPERATING mode Selection	1	1	1	1	1	1	1	1
Pn115	SWITCHING mode in Position Control	For Pn002= 2,3,4 or 5: 10 For Pn002= 0 or 1: 0							
Pn116	Gain Switching Delay Time in Position Control	30	30	30	30	30	30	30	30
Pn117	Gain Switching Level in Position Control	50	50	50	50	50	50	50	50
Pn118	Gain Switching Hysteresis in Position Control	33	33	33	33	33	33	33	33
Pn119	Position Gain Switching Time	33	33	33	33	33	33	33	33
Pn120	SWITCHING mode in Speed Control	0	0	0	0	0	0	0	0
Pn121	Gain Switching Delay Time in Speed Control	0	0	0	0	0	0	0	0
Pn122	Gain Switching Level in Speed Control	0	0	0	0	0	0	0	0
Pn123	Gain Switching Hysteresis in Speed Control	0	0	0	0	0	0	0	0
Pn124	SWITCHING mode in Force Control	0	0	0	0	0	0	0	0
Pn125	Gain Switching Delay Time in Force Control	0	0	0	0	0	0	0	0
Pn126	Gain Switching Level in Force Control	0	0	0	0	0	0	0	0
Pn127	Gain Switching Hysteresis in Force Control	0	0	0	0	0	0	0	0
Pn605	Gain 3 Effective Time	0	0	0	0	0	0	0	0
Pn606	Gain 3 Ratio Setting	100	100	100	100	100	100	100	100
Pn607	Force Command Value Offset	Estimated if Pn002=3,4 or 5							
Pn608	Forward Direction Force Offset	Estimated If Pn002= 4 or 5							
Pn609	Reverse Direction Force Offset	Estimated if Pn002= 4 or 5							
Pn610.0, Pn610.3	Function Expansion Setting	0	0	0	0	0	0	0	0
Pn611	Electric Current Response Setting	100	100	100	100	100	100	100	100
Pn613	Mass ratio 2	0	0	0	0	0	0	0	0
Pn623	Disturbance Force Compensation Gain	0	0	0	0	0	0	0	0
Pn624	Disturbance Observer Filter Setting	0	0	0	0	0	0	0	0

*1. This is limited at the minimum value of 10 if a 17-bit absolute encoder is used.

- The parameters Pn103, Pn108, Pn110 to Pn127, Pn605, Pn606, Pn610, Pn611, Pn613, Pn623 and Pn624 are set to fixed values.

Related Parameters

Parameters related to the REALTIME AUTOTUNING are:

Parameter	Description	Explanation
Pn002	Realtime autotuning mode	By setting this parameter you decide which of the automatic adjustable algorithms you want to use. Those algorithms are: - Mass estimation. - Automatic gain setting. - Gain switching. - Unbalanced load. - Friction compensation.
Pn003	Rigidity setting	Selects the right set of gains according to the selected rigidity.
Pn200	Adaptative filter setting	Select whether to use or not the adaptative filter setting.
Pn631	Realtime autotuning estimation time	Selects how quick the realtime autotuning reflects the changes in the motor load: 0: No changes are reflected. 1: Changes are reflected slowly (1 minute time constant). 2: Changes are reflected gradually (few seconds time constant). 3: Changes are reflected instantaneously (changes are applied as soon as they are detected).
Pn632	Realtime autotuning custom setting	When realtime autotuning mode is set to custom mode, select here the algorithms that you want to enable: Bit 0, 1: Mass estimation enabled. Bit 2, 3: Update of the mass estimation enabled. Bit 4, 5, 6: Update of friction compensation and unbalanced load enabled. Bit 7: Update of gain adjustment. Bit 8: Forces the "fixed parameter". Bit 9, 10: Enables the gain switching.

10-3 Manual Tuning

Basic Settings

As described before, the Accurax G5-Linear have a realtime autotuning function. However, when the gain cannot be properly adjusted due to restrictions such as load conditions even if realtime autotuning is performed, or when the optimum responsiveness or stability is required to match each load, readjustment maybe required.

This section describes how to perform manual tuning for each CONTROL mode and function.

Before Manual Setting

More reliable adjustment can be performed quickly by using waveform monitoring with the data tracing function of CX-Drive or by measuring the analog voltage waveform with the monitor function.

Analog Monitor Output

The actual motor speed, command speed, force, and number of accumulated pulses can be measured in the analog voltage level using an oscilloscope or other device. The type of signal to output and the output voltage level are set with Analog Monitor 1 Selection (Pn416) and Analog Monitor 2 Selection (Pn418) settings. For details, refer to 12-2Parameter List12-12.

CX-Drive Data Tracing Function

Commands to the motor and motor operation (speed, force command, and position error) can be displayed on a computer as waveforms. Refer to the CX-Drive Operation Manual (SBCE-337).

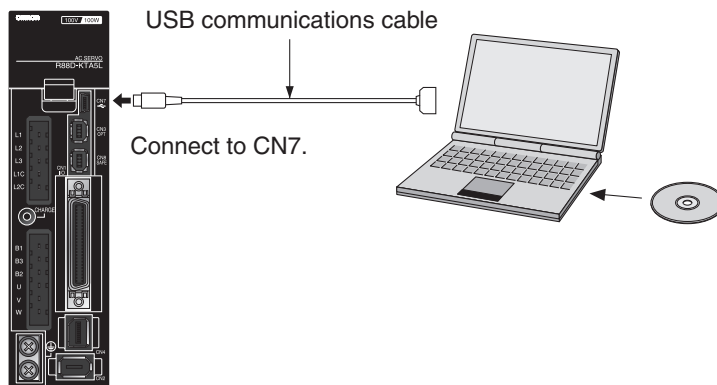

POSITION CONTROL Mode Adjustment

Use the following procedure to perform the adjustment in position control for the Accurax G5-Linear Series.

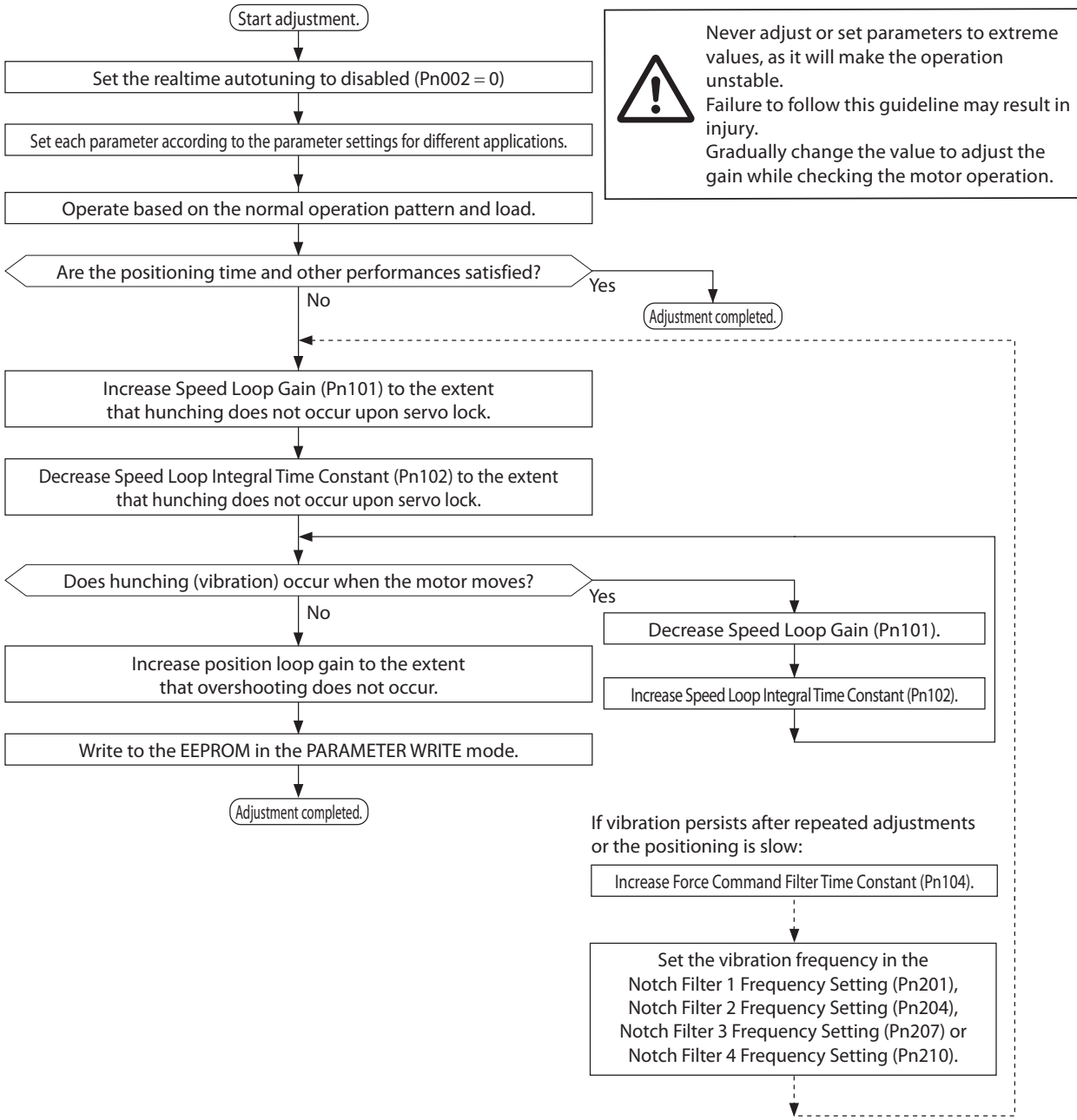

SPEED CONTROL Mode Adjustment

Adjustments in speed control for the Accurax G5-Linear Series are very similar to POSITION CONTROL mode adjustment.

Use the following procedure to perform the adjustment.

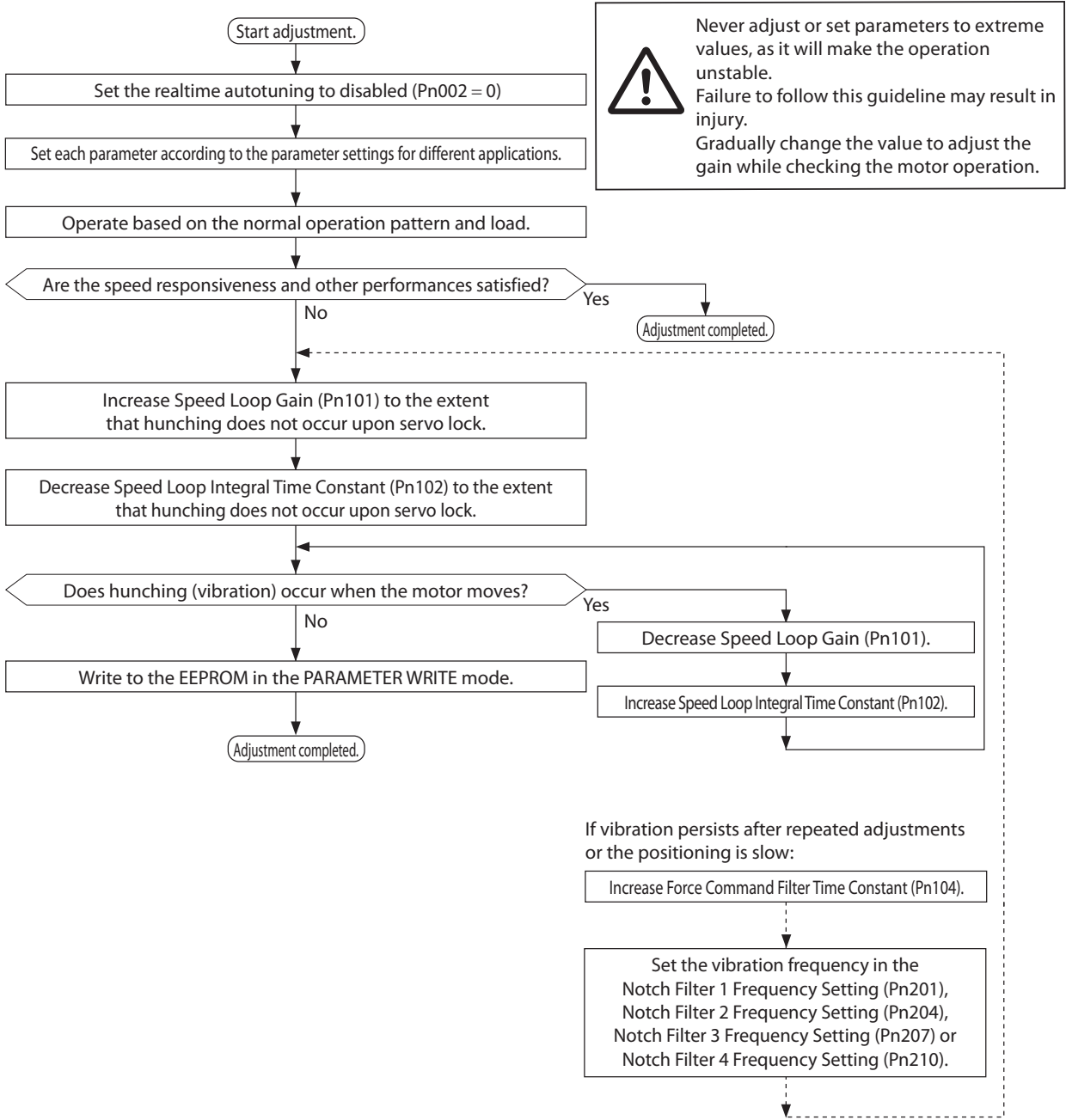

10

Adjustment Functions

Servo Manual Tuning Method

The following 4 parameters are the basic servo adjustment parameters. If desired operation characteristics are obtained by adjusting the following 4 parameters, the adjustments of other parameters are not necessary.

Parameter number	Parameter name	Default setting	Parameter number 2
Pn100	Position Loop Gain	40.0 [1/s]	Pn105
Pn101	Speed Loop Gain	50.0 Hz	Pn106
Pn102	Speed Loop Integral Time Constant	20.0 ms	Pn107
Pn104	Force Command Filter Time Constant	0.80 ms	Pn109

Adjustment of Each Parameter

The control loop for the servo consists of, from the outside, a position loop, speed loop and current loop.

The inner loop is affected by the outer loop, and the outer loop is affected by the inner loop. What determines the default setting includes the structure and the rigidity of the machine, and the mass ratio.

Check the tables for rigidity setting in section 10.2 as reference guide for those settings.

Pn100 and Pn105 Position Loop Gain

This loop controls the number of pulses from encoder to be the designated number of pulses. This is called an error counter, and when the pulse is equal to or lower than the specified value, positioning is completed and the signal is output.

The ratio of maximum speed used and error counter is called a position loop gain.

$$\text{Position loop gain [1/s]} = \frac{\text{Command maximum speed [pps]}}{\text{Error counter accumulated pulse (P)}}$$

For the position loop gain, use the inverse of Speed Loop Integral Time Constant (Pn102) as a guide for setting. Setting Pn102 to 100 ms results in 10 [1/s].

There will be no overshooting under this condition. To quicken positioning, increase the value of position loop gain. If the value is too large, overshooting or vibration will occur. In such cases, set the value smaller.

If the speed loop or the current loop is vibrating, adjusting the position loop does not eliminate the vibration.

Response to the position loop gain adjustment is illustrated below.

- ◆ If the position loop gain is high, an overshooting occurs.

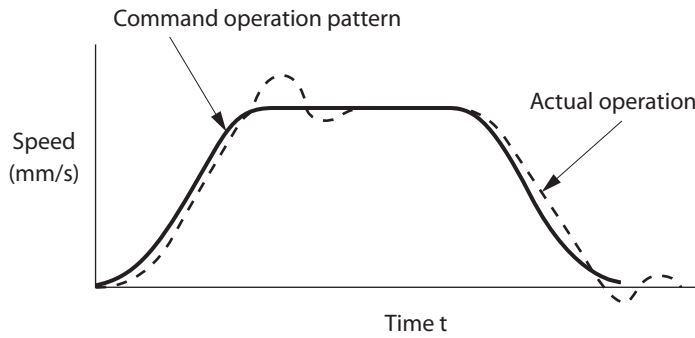

- ◆ If the position loop gain is low, positioning completion speed becomes slow.

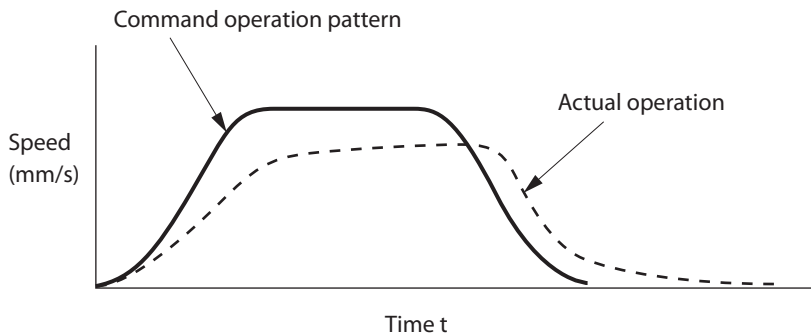

Pn101 and Pn106 Speed Loop Gain

The speed loop gain determines the responsiveness of the servo. This value becomes the response frequency if the Mass Ratio (Pn004) is set correctly. Increasing the value of the speed loop gain improves the responsiveness and quickens positioning, but vibration is more likely to occur. Adjustment must be made so vibration will not occur. This is related to Speed Loop Integral Time Constant (Pn102), and by increasing the integration time constant, the speed loop gain value can be increased.

- ♦ If the speed loop gain is low, the speed response becomes slow and a large overshooting occurs. In such case, increase the speed loop gain.

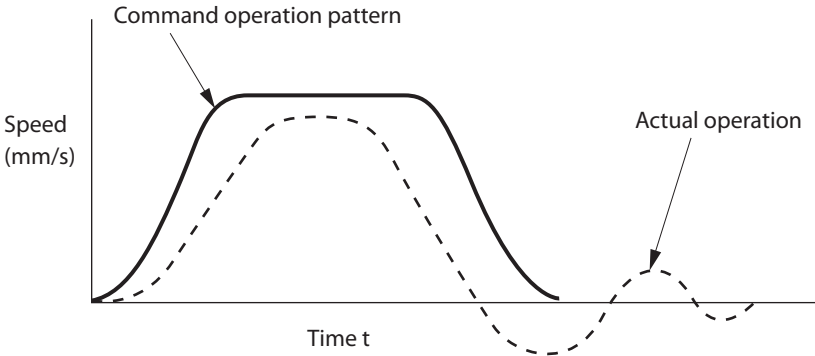

- ♦ If the speed loop gain is high, vibrations are more likely to occur. Vibration or resonance may not disappear. In such case, decrease the speed loop gain.

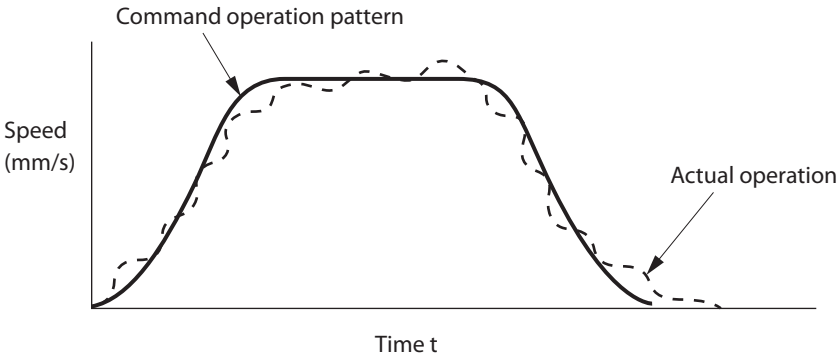

***Note:** The maximum suitable value for the Speed Loop Gain depends on the mechanical rigidity and correspond to the “cut-off frequency” that can be determined by the FFT analisi with the CX-Drive.

Pn102 and Pn107 Speed Loop Integral Time Constant

The speed loop integral time constant also determines the responsiveness of the servo.

- ♦ If the speed loop integral time constant is low, vibration or resonance occur. In such case, increase the speed loop integral time constant.

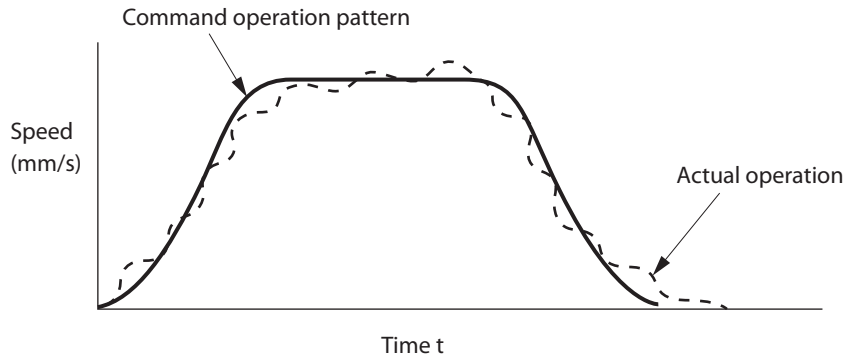

- ♦ If the speed loop integral time constant is high, the response is delayed. The servo rigidity becomes weak. In such case, decrease the speed loop integral time constant.

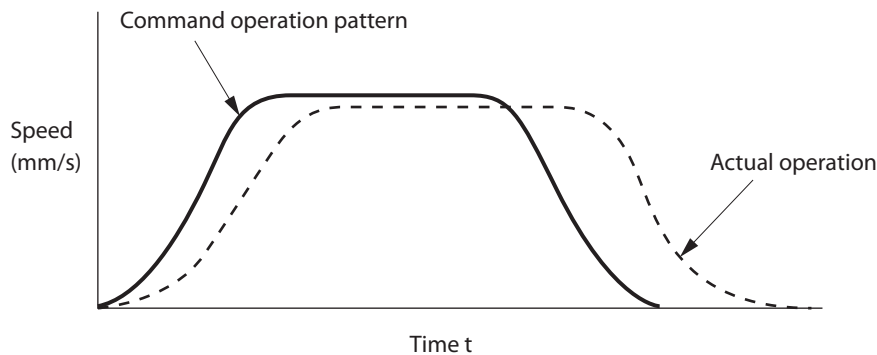

Pn104 and Pn109 Force Command Filter Time Constant (Current Loop Input Adjustment)

The force command filter applies a filter so the current command from the speed loop becomes smooth. The result is a smooth current flow which suppresses vibration.

The default setting of the filter time constant is 80 (0.8 ms).

Increase the value to reduce vibration. Increasing the value slows the response.

As a guide, aim for about 1/25 of the Speed Loop Integral Time Constant (Pn102).

Also, the force command filter reduces vibration due to the machine rigidity.

This is related to Speed Loop Gain (Pn101), and if Pn101 is too large, increasing the force command filter time constant does not reduce vibration.

If there is machine resonance such as with the ball screw, vibration is reduced by using notch filters such as Pn201, Pn204, Pn207 and Pn210. Or, enable the adaptive filter.

Other Adjustments

If the force loop is saturated because the acceleration time is short or the load force is large, an overshooting occurs for the speed response. In such case, increase the acceleration time to prevent the force from saturating.

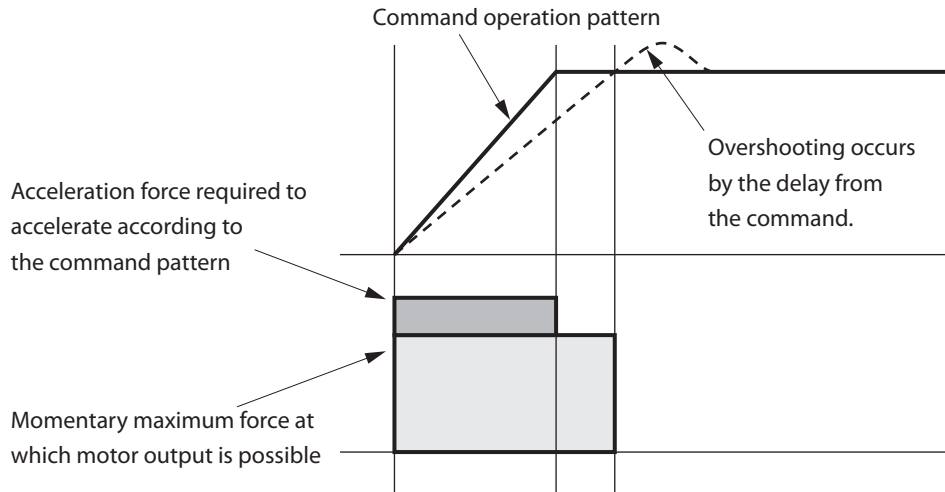

FORCE CONTROL Mode Adjustment

This is a force control based on the speed control loop where the speed limit is the speed limit value from Speed Limit (Pn304, Pn305, Pn306 or Pn307). This section describes the settings for these speed limit values.

Setting Speed Limit Values

- If Force Command/Speed Limit Selection (Pn317) is 0, speed limit will be the value set by Speed Limit Value Setting (Pn321) and Reverse Direction Speed Limit Value Setting (Pn322). If Force Command/Speed Limit Selection (Pn317) is 1, the speed limit will be the value obtained by converting the voltage applied to analog input 1 with Force Command Scale (Pn319).
- When the motor speed approaches the speed limit value, the speed control switches to that using Speed Limit Value Setting (Pn321) and Reverse Direction Speed Limit Value Setting (Pn322) as commands.
- To have a stable operation while the speed is limited, the parameter should be set according to "SPEED CONTROL Mode Adjustment".

The force may not be produced as specified by the force command because the input to the force limit section will be small, when the speed limit values in Speed Limit Value Setting (Pn321) and Reverse Direction Speed Limit Value Setting (Pn322) are too low, when the speed loop gain is too low, or when the speed loop integral time constant is 10,000 (disabled).

11

Error and Maintenance

This chapter explains the items to check when problems occur, error diagnosis using the alarm LED display and measures, error diagnosis based on the operating condition and measures, and periodic maintenance.

11-1 Error Processing	11-2
Preliminary Checks When a Problem Occurs.....	11-2
Precautions When a Problem Occurs.....	11-3
Replacing the Linear Servomotor and Servo Drive.....	11-4
11-2 Warning List	11-5
11-3 Alarm List	11-6
11-4 Troubleshooting	11-11
Error Diagnosis Using the Alarm Displays	11-11
Error Diagnosis Using the Operation Status	11-18
11-5 Periodic Maintenance	11-23
Linear Servomotor Limit.....	11-23
Servo Drive Limit.....	11-24

11-1 Error Processing

Preliminary Checks When a Problem Occurs

This section explains the preliminary checks and analytical softwares required to determine the cause of a problem if one occurs.

Checking the Power Supply Voltage

- ♦ Check the voltage at the power supply input terminals.

Main circuit power supply input terminal (L1, L2, L3)

R88D-KTxL-L (100 to 400 W) : Single-phase 100 to 115 VAC (85 to 127 V) 50/60 Hz

R88D-KTxH-L (200 W to 1.5 kW) : Single-phase 200 to 240 VAC (170 to 264 V) 50/60 Hz

(800 W to 1.5 kW) : 3-phase 200 to 240 VAC (170 to 264 V) 50/60 Hz

(2 kW) : 3-phase 200 to 230 VAC (170 to 253 V) 50/60 Hz

R88D-KTxF-L (600 W to 5 kW) : 3-phase 380 to 480 VAC (323 to 528 V) 50/60 Hz

Control circuit power supply input terminal (L1C, L2C)

R88D-KTxL-L (100 to 400 W) : Single-phase 100 to 115 VAC (85 to 127 V) 50/60 Hz

R88D-KTxH-L (200 W to 1.5 kW) : Single-phase 200 to 240 VAC (170 to 264 V) 50/60 Hz

(2 kW) : Single-phase 200 to 230 VAC (170 to 253 V) 50/60 Hz

R88D-KTxF-L (600 W to 5 kW) : 24 VDC (21.6 to 26.4 V)

If the voltage is out of this range, there is a risk of operation failure, so be sure that the power supply is correct.

- ♦ Check the voltage of the sequence input power supply. (+24 VIN terminal (CN1 pin 7))
Within the range of 11 to 25 VDC.

If the voltage is out of this range, there is a risk of operation failure. Be sure that the power supply is correct.

Checking Whether an Alarm Has Occurred

- ♦ Make an analysis using the 7-segment LED display area in the front of the drive and using the Operation keys.
- ♦ When an alarm has occurred
... Check the alarm display that is displayed (xx) and make an analysis based on the alarm that is indicated.
- ♦ When an alarm has not occurred
... Make an analysis according to the error conditions.
- ♦ In either case, refer to "11-4 Troubleshooting" (P.11-11) for details.

Precautions When a Problem Occurs

When checking and verifying I/O after a problem has occurred, the drive may suddenly start to operate or suddenly stop, so always take the following precautions.

You should assure that anything not described in this manual is not possible with this product.

Precautions

- Disconnect the wire before checking for cable breakage. Even if you test conduction with the cable connected, test results may not be accurate due to conduction via bypassing circuit.
- If the encoder signal is lost, the motor may run away, or an error may occur.
- When performing tests, first check that there are no persons in the vicinity of the equipment, and that the equipment will not be damaged even if the motor runs away.
Before performing the tests, verify that you can immediately stop the machine using an immediate stop even if it runs away.

Replacing the Linear Servomotor and Servo Drive

Use the following procedure to replace the Linear Servomotor or Servo Drive.

Replacing the Linear Servomotor

- 1. Replace the linear servomotor.**
- 2. In case of Iron-core motor, dismount the motor following the linear motor installation instruction in the inverse order.**
 - ♦ Move the motor to one side of the slider.
 - ♦ Remove the magnet track in the free side.
 - ♦ Move the motor to the side of the slider where you removed the magnet.
 - ♦ Dissassemble the motor while staying in the zone without magnet to avoid problems with the attraction force.
- 3. Install the new motor following the installation instructions.**

Replacing the Servo Drive

- 1. Copy the parameters.**

Use the Operation keys on the drive to write down all the contents of parameter settings.
- 2. Replace the drive.**
- 3. Set the parameters.**

Use the Operation keys on the drive to set all the parameters.

11-2 Warning List

This is a function to output a warning signal before the protective function operates to notify the overload and other statuses in advance,
Set the warning output type to Warning Output Selection 1 (Pn440) and Warning Output Selection 2 (Pn441).



Precautions for Correct Use

- Each warning automatically returns to the status before it occurred once the system recovers from the error. However, for the time set in the Warning Latch Hold Time Selection (Pn627), the warning status will be held. To clear the warning during the latch hold time, do so by performing the same procedures as alarm clear.

Warning List

Warning number	Warning name	Latch* ¹	Warning occurrence condition	Warning Output Selection (Pn440, Pn441) ^{*2}	Warning Mask Setting (Pn638)
A0	Overload warning	√	The load ratio is 85% or more of the protection level.	1	bit 7
A1	Excessive regeneration warning	√	The regeneration load ratio is 85% or more of the protection level.	2	bit 5
A3	Fan warning	√	The fan stop status continues for 1 s.	4	bit 6
A4	Motor overheat warning	√	Serial Converter detects overheat warning.	5	bit 4
A6	Vibration detection warning	√	Vibration is detected.	7	bit 9
A7	Limit detection warning	Always fixed with no time limit	The limit of the capacitor or the fan is below the specified value.	8	bit 2
A8	Encoder error warning	√	The encoder detected a warning.	9	bit 8
A9	Encoder communications warning	√	The number of occurrences of encoder communications error exceeded the specified value.	10	bit 10

*1. The "√" fields can be set to 1 to 10 s in the Warning Latch Hold Time Selection (Pn627) or to the no-time limit setting.

*2. Select the type of warning to be output in warning output 1 (WARN1) and warning output 2 (WARN2) in the Warning Output Selection 1 (Pn440) and Warning Output Selection 2 (Pn441). If you set this to 0, all warning types will be output. Do not set it to a value other than above.

*3. Each warning detection can be masked using the Warning Mask Setting (Pn638). The table shows the corresponding bits.

The warning detection is masked when the bit = 1.

11-3 Alarm List

If the drive detects an error, the alarm output (ALM) will turn ON, the power drive circuit in the drive will turn OFF, and the alarm code will be displayed.



Precautions for Correct Use

- ♦ Refer to "Error Diagnosis Using the Alarm Displays"(P.11-11) for appropriate alarm measures.
- ♦ Release the alarm using one of the following methods. Remove the cause of the alarm first.
 - Input the alarm reset input (RESET) signal.
 - Turn OFF the power supply, then turn it ON again.
 - Execute the alarm reset with CX-Drive.

However, some alarms can only be reset by turning the power supply OFF then ON again. Refer to the next item "Alarm List".

- ♦ If you release an alarm while the operation command (RUN) is turned ON, the Servo Drive will start operation as soon as the alarm is released, which is dangerous. Be sure to turn OFF the RUN before clearing the alarm.

If the RUN is always ON, first check safety sufficiently before clearing the alarm.
 - ♦ When an alarm occurs, the servodrive latches the status of the servodrive just before the alarm occurrence. Those latched values can be read with the software tool for diagnostics. Refer to the CX-Drive for details.
 - ♦ The stop mode in case of an alarm may vary depending on the "Immediate stop" attribute in each alarm.
-

Alarm List

Error number		Error detection function	Detection details and probable cause	Attribute		
Main	Sub			History	Can be cleared	Immediate stop *1
11	0	Control power supply undervoltage	The DC voltage of the main circuit fell below the specified value while the operation command (RUN) input was ON.	–	√	–
12	0	Overvoltage	The DC voltage in the main circuit is abnormally high.	√	√	–
13	0	Main power supply undervoltage (Insufficient voltage between P and N)	The DC voltage of the main circuit is low.	–	√	–
	1	Main power supply undervoltage (AC cut-off detection)	A location was detected where the main circuit AC power supply is cut off.	–	√	–
14	0	Overcurrent	Overcurrent flowed to the IGBT.	√	–	–
	1	IPM error	Motor power line ground fault or short circuit.	√	–	–
15	0	Drive overheat	The temperature of the drive radiator exceeded the specified value.	√	–	√
16	0	Overload	Operation was performed with force significantly exceeding the rating for several seconds to several tens of seconds.	√	√	–
18	0	Regeneration overload	The regenerative energy exceeds the processing capacity of the Regeneration Resistor.	√	–	√
	1	Regeneration Tr error	An error was detected in a drive regeneration drive Tr.	√	–	–
24	0	Error counter overflow	The error counter accumulated pulse exceeds the set value for the Error Counter Overflow Level.	√	√	√
	1	Excessive speed error	The difference between the internal position command speed and the actual speed exceed the value set in Pn602.	√	√	√
26	0	Overspeed	The motor movement speed exceeded the set value of the Overspeed Level set (Pn910).	√	√	√
	1	Overspeed 2	The motor movement speed exceeded the set value of the Overspeed Level set 2 (Pn615).	√	√	–
27	0	Command pulse frequency error	A command pulse frequency exceeds the maximum range (Pn532) by 1.2 times.	√	√	√
	1	Command pulse multiplier error	Electronic ratio is not set to a suitable value.	√	√	√

11-3 Alarm List

Error number		Error detection function	Detection details and probable cause	Attribute		
Main	Sub			History	Can be cleared	Immediate stop *1
28	0	Pulse regeneration error	The pulse regeneration output frequency exceeded the limit.	√	√	√
29	0	Error counter overflow	Error counter value based on the encoder pulse reference exceeded 2^{29} (536,870,912).	√	√	–
30	0	Safety input error	Safety input signal turned OFF.	–	√	–
33	0	Interface input duplicate allocation error 1	A duplicate setting for the interface input signals was detected.	√	–	–
	1	Interface input duplicate allocation error 2		√	–	–
	2	Interface input function number error 1	An undefined number was detected in the interface input signal allocations.	√	–	–
	3	Interface input function number error 2		√	–	–
	4	Interface output function number error 1	An undefined number was detected in the interface output signal allocations.	√	–	–
	5	Interface output function number error 2		√	–	–
	6	Counter reset allocation error	The counter reset function was allocated to something other than input signal SI7.	√	–	–
	7	Command pulse prohibition input allocation error	The command pulse prohibition input function was allocated to something other than input signal SI10.	√	–	–
34	0	Overrun limit error	The motor exceeded the allowable operating range set in the Overrun Limit Setting (Pn514) with respect to the position command input.	√	√	–
36	0 to 2	Parameter error	Data in the Parameter Save area was corrupted when the power supply was turned ON and data was read from the EEPROM.	–	–	–
37	0 to 2	Parameters destruction	The checksum for the data read from the EEPROM when the power supply was turned ON does not match.	–	–	–
38	0	Drive prohibition input error	The forward drive prohibition and reverse drive prohibition inputs are both turned OFF.	–	√	–
39	0	Excessive analog input 1	A current exceeding the Speed Command/Force Command Input Overflow Level Setting (Pn424, Pn427 or Pn430) was applied to the analog command input (pin 14).	√	√	√
	1	Excessive analog input 2		√	√	√
	2	Excessive analog input 3		√	√	√
50	0	Encoder connection error	An error was detected in encoder connection.	√	–	–
	1	Encoder communications data error	An error was detected in encoder communications data.	√	–	–

Error number		Error detection function	Detection details and probable cause	Attribute		
Main	Sub			History	Can be cleared	Immediate stop *1
51	0	Encoder status error 0	An encoder error code was detected.	√	–	–
	1	Encoder status error 1		√	–	–
	2	Encoder status error 2		√	–	–
	3	Encoder status error 3		√	–	–
	4	Encoder status error 4		√	–	–
	5	Encoder status error 5		√	–	–
55	0	Same	Same	√	–	–
	1	Same	Same	√	–	–
	2	Same	Same	√	–	–
	3	Hall sensor logic error	Logic error in the Hall sensor signal from the Serial Converter Unit	√	–	–
	4	SinCos phase loss error	Phase error in SinCos phase from the Serial Converter Unit.	√	–	–
60	0	Motor setting error	No initial setting has been made for the linear motor or encoder.	–	–	–
	1	Motor combination error 1	Rated or maximum current for the motor exceeds the maximum value for the drive.	–	–	–
	2	Motor combination error 2	The motor rated current is too small compared to the servodrive rated current. The ratio between motor mass and load mass is too large . Current PI gains are too large Ratio between motor rated current and peak current exceeds 500%.	–	–	–
61	0	Magnetic pole position estimation error 1	Magnetic pole estimation did not complete properly.	√	√	–
	1	Magnetic pole position estimation error 2	The motor did not stop inside the time set in Pn927.	√	√	–
	2	Magnetic pole position estimation error 3	Pn920 is set to 3 and magnetic pole estimation has never been executed. Pn920 is set to 3 and the encoder is not absolute.	–	–	–
87	0	Forced alarm input error	The forced alarm input signal was input.	–	√	–
93	3	Serial Encoder connection error	The setting of Pn323 is inconsistent with the encoder type connected.			

*1. An immediate stop means an error causing an immediate stop when the Pn510 "Stop Selection for Alarm Generation" is set to 4 to 7. For details, refer to "Stop Selection for Alarm Generation"(P.8-48).

Extended Alarms

Error No.		Error detection function	Detection details and probable cause
Main	Sub		
70	0	U-Phase Phase Current Detection Error	U-Phase Current Detection Value is abnormal when objecting servo off to servo on
	1	W-Phase Phase Current Detection Error	W-Phase Current Detection Value is abnormal when objecting servo off to servo on
	2	Current Detection System Error	Setting value of Current Detection System U is abnormal
71	0	AI2 Input Error	Analog Input Voltage 2 value is abnormal +11 V over is lasting 200 ms
	1	AI3 Input Error	Analog Input Voltage 3 value is abnormal +11 V over is lasting 200 ms
72	0	Thermal Error	Hardware is abnormal
73	0	VDC Detection System Error	Hardware is abnormal
76	0	Internal RAM Error	Microcomputer is abnormal
	1	Internal ROM Error	Internal ROM is abnormal
77	0	Stack Error	Lack of Stack Area
96	0	LSI Initialization Error	Falut of MNM1223 initialization
99	0	Hardware Error	Hardware error detected in the power circuit

11-4 Troubleshooting

If an error occurs in the machine, determine the error conditions from the alarm displays and operation status, identify the cause of the error, and take appropriate measures.

Error Diagnosis Using the Alarm Displays

Alarm display	Error conditions	Status when error occurs	Cause	Measures
11	Power supply undervoltage	Occurs when the servo is turned ON.	·The power supply voltage is low. ·Momentary power interruption occurred. ·Power supply capacity is insufficient. ·The power supply voltage is reduced because the main power supply is OFF. ·The main power supply is not input.	·Increase the power supply capacity. ·Change the power supply. ·Turn ON the power supply.
			·Power supply capacity is insufficient.	·Increase the power supply capacity.
			·Phase loss	·Connect the phases (L1, L2, L3) of the power supply voltage correctly. ·For single-phase, connect to L1 and L3 correctly.
			·The main circuit power supply is damaged. ·Control PCB error.	·Replace the drive.
12	Overvoltage	Occurs when the power supply is turned ON.	·Main circuit power supply voltage is out of allowable range.	·Change the main circuit power supply voltage to within allowable range.
		Occurs when the motor is decelerating.	·Load mass is too large.	·Calculate the regenerative energy and connect an External Regeneration Resistor with the required regeneration absorption capacity. ·Extend the deceleration time.
			·Main circuit power supply voltage is out of allowable range.	·Change the main circuit power supply voltage to within allowable range.
	Occurs during descent (vertical axis).	·Gravitational force is too large.	·Add a counterbalance to the machine to lower gravitational force. ·Reduce the descent speed. ·Calculate the regenerative energy and connect an External Regeneration Resistor with the required regeneration absorption capacity.	

11-4 Troubleshooting

Alarm display	Error conditions	Status when error occurs	Cause	Measures
13	Main circuit power supply undervoltage	Occurs when the servo is turned ON.	<ul style="list-style-type: none"> ·The power supply voltage is low. ·Momentary power interruption occurred. ·Power supply capacity is insufficient. ·The power supply voltage is reduced because the main power supply is OFF. ·The main power supply is not input. 	<ul style="list-style-type: none"> ·Check the power supply capacity. ·Change the power supply. ·Turn ON the power supply. ·Extend the Momentary Hold Time (Pn509).
		Occurs when the power supply is turned ON.	·Phase loss	<ul style="list-style-type: none"> ·Correctly connect the phases of the power supply voltage. ·Correctly connect the single-phase.
			<ul style="list-style-type: none"> ·The main circuit power supply is damaged. ·Control PCB damage. 	<ul style="list-style-type: none"> ·Replace the drive.
14	Overcurrent	Occurs when the servo is turned ON.	·Control PCB error	<ul style="list-style-type: none"> ·Replace the drive.
			<ul style="list-style-type: none"> ·The motor power line is short-circuited or ground-faulted between phases. 	<ul style="list-style-type: none"> ·Repair the short-circuited or ground-faulted power line. ·Measure the insulation resistance at the motor and, if there is a short circuit, replace the motor.
			·Phase U, phase V, phase W, and the ground are wired incorrectly.	<ul style="list-style-type: none"> ·Wire correctly.
			·Motor winding is burned out.	<ul style="list-style-type: none"> ·Measure the winding resistance, and if the winding is burned out, replace the motor.
			·The relay for the dynamic brake has been deposited.	<ul style="list-style-type: none"> ·Do not frequently input the operation command (RUN) input. ·Do not operate the system by turning the servo ON and OFF.
			·Motor non-conformity	<ul style="list-style-type: none"> ·Use a motor that is appropriate for use with the drive.
			·The pulse input timing is too soon.	<ul style="list-style-type: none"> ·Wait at least 100ms before inputting pulses after turning ON the operation command (RUN).
			<ul style="list-style-type: none"> ·The resistor in the drive is abnormally overheating. 	<ul style="list-style-type: none"> ·Reduce the ambient temperature of the drive to 55°C or lower. ·If the relay does not click when the power supply is turned ON, replace the drive.

Alarm display	Error conditions	Status when error occurs	Cause	Measures
15	Drive overheat	Occurs during operation.	<ul style="list-style-type: none"> ·The ambient temperature is too high. ·The load is too large. 	<ul style="list-style-type: none"> ·Lower the ambient temperature. ·Increase the capacity of the drive and motor. ·Reduce the load. ·Extend the acceleration/ deceleration times.
16	Overload	Occurs when the servo is turned ON.	·There is an error in the motor wiring (the wiring or the connections are faulty).	·Wire the motor power cable correctly.
			·The electromagnetic brake is ON.	·Turn OFF the brake.
			·The Servo Drive is faulty.	·Replace the drive.
		Occurs during operation.	·The effective force exceeds the rated force. ·The initial force exceeds the maximum force.	·Review the load conditions and operating conditions. ·Review the motor capacity.
			·Unusual noise or vibration is caused by faulty gain adjustment.	·Adjust the gain correctly.
			·The Servo Drive is faulty.	·Replace the drive.
			·Wrong setting of overload curve (Pn929).	·Select the overload curve in Pn929 according to the motor conditions.

11-4 Troubleshooting

Alarm display	Error conditions	Status when error occurs	Cause	Measures
18	Regeneration overload	Occurs when the motor is decelerating.	·Load mass is too large.	·Calculate the regenerative energy and connect an External Regeneration Resistor with the required regeneration absorption capacity. ·Extend the deceleration time.
			·The deceleration time is too short. ·The motor movement speed is too high.	·Reduce the motor movement speed. ·Extend the deceleration time. ·Calculate the regenerative energy and connect an External Regeneration Resistor with the required regeneration absorption capacity.
			·The operating limit of the External Regeneration Resistor is limited to 10% duty.	·Set Pn016 to 2. For details, refer to "Parameters Details".
		Occurs during descent (vertical axis).	·Gravitational force is too large.	·Add a counterbalance to the machine to lower gravitational force. ·Reduce the descent speed. ·Calculate the regenerative energy and connect an External Regeneration Resistor with the required regeneration absorption capacity.
			·The operating limit of the External Regeneration Resistor is limited to 10% duty.	·Set Pn016 to 2. For details, refer to "Parameters Details".

Alarm display	Error conditions	Status when error occurs	Cause	Measures
24	Error counter overflow	Occurs when the motor does not rotate even when command pulses are input.	·The motor power line or the encoder wiring is incorrect.	·Wire correctly.
			·The motor is mechanically held.	·If the motor shaft is held, release it. ·Release the electromagnetic brake.
			·Control PCB error	·Replace the drive.
		Occurs during high-speed movement.	·The motor power line or the encoder wiring is incorrect.	·Wire correctly.
		Occurs when a long string of command pulses is given.	·Gain adjustment is insufficient.	·Adjust the gain.
			·The acceleration/ deceleration is too rapid.	·Extend the acceleration/ deceleration times.
		·The load is too large.	·Reduce the load. ·Select a suitable motor.	
Occurs during operation.	·The set value for the Error Counter Overflow Level (Pn014) is exceeded.	·Increase the set value of Pn014. ·Reduce the movement speed. ·Reduce the load. ·Extend the acceleration/ deceleration times.		
26	Overspeed	Occurs during high-speed movement.	·The speed command input is too large.	·Set the command pulse frequency to 500Kpps max.
			·The setting for the Electronic Ratio Numerator (Pn009, Pn500 to Pn502) is not appropriate.	·Set the electronic ratio numerator so that the command pulse frequency is 500 Kpps max.
			·The maximum movement speed is exceeded due to overshooting.	·Adjust the gain. ·Reduce the maximum command speed.
			·The encoder is wired incorrectly.	·Wire correctly.
		Occurs when force limit switching function is used.	·The set value for the Overspeed Detection Level setting (Pn910) is exceeded.	·If force limit switching function is used, correctly set the allowable operating speed for Pn014.
27	Command pulse error	Occurs when control signal is input or command is input.	·The command pulse input frequency exceeded the limit.	·Check the command pulse input. ·Increase the set value of Pn532.
			·The setting for the Electronic Ratio Numerator (Pn009, Pn500 to Pn502) is not appropriate.	·Set the electronic ratio numerator so that the command pulse frequency is 500Kpps max.
28	Pulse regeneration error	Occurs during operation.	·The pulse regeneration output frequency exceeded the limit.	·Check the set value of Pn011 and Pn503. ·Set Pn533 to 0 to disable the function.

11-4 Troubleshooting

Alarm display	Error conditions	Status when error occurs	Cause	Measures
29	Error counter overflow	Occurs during operation.	·The error counter value for the encoder pulse reference exceeded 2^{29} (536,870,912).	·Check that the motor rotates according to the position command. ·Check on the force monitor that the output force is not saturated. ·Adjust the gain. ·Increase the setting for Pn013 or Pn524 to the maximum. ·Wire the encoder correctly.
30	Safety input error	Occurs during operation.	·Safety input signal turned OFF.	·Check the statuses of safety inputs 1 and 2.
33	Interface I/O allocation error	Occurs when the power supply is turned ON.	·There is a duplicate setting in the I/O signal function allocation. ·Specify the undefined number with the I/O signal function allocation.	·Set the function allocation correctly.
			·There is a mistake in the counter function allocation.	·Allocate to SI7.
			·There is a mistake in the command pulse prohibition input function allocation.	·Allocate to SI10.
34	Overrun limit error	Occurs during operation.	·The Overrun Limit Setting (Pn514) was exceeded during operation.	·Adjust the gain. ·Increase the set value of Pn514. ·Set Pn514 to 0 to disable the function.
36	Parameter error	Occurs when the power supply is turned ON.	·There are data errors in the parameters that were read.	·Reset all parameters.
			·The drive is faulty.	·Replace the drive.
37	Parameters destruction	Occurs when the power supply is turned ON.	·The parameters that were read are corrupt.	·Replace the drive.
38	Drive prohibition input error	Occurs when the servo is turned ON. Or, occurs during operation.	·The forward drive prohibition (POT) input and reverse drive prohibition (NOT) input were both OFF at the same time.	·Wire correctly. ·Replace the limit sensor. ·Check whether the power supply for control is input correctly. ·Check whether the setting for Drive Prohibition Input Selection (Pn504) is correct.
39	Excessive analog input 1	Occurs during operation.	·The voltage input to pin 14 is too high.	·Reduce the input voltage. ·Change the value for Pn424, Pn427, and Pn430.

Alarm display	Error conditions	Status when error occurs	Cause	Measures
50	Encoder communications error	Occurs during operation.	·The disconnection detection function was activated because communications between the encoder and drive were interrupted.	·Wire correctly. ·Fix the locations that are disconnected.
			·There was a communications error in data from encoder.	·Provide the required encoder power supply voltage. ·Wire correctly. ·Connect the shield to FG.
51	Encoder status error	Occurs during operation.	·An encoder error code was detected.	·Check the encoder specifications. ·From the front panel, clear the encoder error, then turn the power supply OFF, then ON again.
55	Phases-A, B, Z connection error	Occurs during operation or at power up.	·A, B, Z wiring is uncorrect. ·A, B, Z wiring is broken.	·Check the wiring.
	Hall sensor error		·Hall sensor wiring is uncorrect. ·Hall sensor wiring is broken.	·Check the wiring.
	SinCos phase error		·SinCos wiring is uncorrect. ·Encoder is damaged.	·Check the wiring. ·Change the encoder.
60	Motor is not suitable for the drive	Occurs at power on.	·The motor setting is uncorrect. ·The motor is unappropriated for the drive.	·Set the motor parameter properly. ·Change the drive for a suitable one.
61	Magnetic pole estimation error	Occurs after magnetic pole estimation sequence.	·The motor is vertical or the friction very high. ·The parameter for the Magnetic pole estimation sequence are not appropriated.	·Magnetic pole estimation cannot be done. Use Hall sensors. ·Change the parameter for the Magnetic pole estimation sequence to proper values.
		Occurs at power-on.	·The wrong encoder type has been selected. ·In absolute encoder, the magnetic pole estimation has never been done.	·Adjust Pn323 according to the encoder type. ·Execute the magnetic pole estimation once.
87	Forced alarm input error	Occurs during operation.	·The forced alarm input signal was input.	·Turn OFF the EMG-STOP signal.
93	Encoder connection error	At power on.	·The setting of Pn323 does not correspond with the detected encoder.	·Select Pn323 according to the encoder type.

Error Diagnosis Using the Operation Status

Symptom	Probable cause	Items to check	Measures
The PWR LED indicator does not light when the power supply is turned ON.	The power supply cable is wired incorrectly.	Check whether the power supply input is within the allowed power supply voltage range.	Supply the correct power supply voltage.
		Check whether the power supply input is wired correctly.	Wire correctly.
The motor does not move even if commands are input from the controller. (Continued on next page)	The operation command (RUN) is OFF.	In MONITOR mode, check whether the RUN signal is ON or OFF.	<ul style="list-style-type: none"> Turn ON the operation command (RUN). Wire correctly.
	The forward drive prohibition (POT) and reverse drive prohibition (NOT) are OFF.	In MONITOR mode, check whether the POT signal and NOT signal are ON or OFF.	<ul style="list-style-type: none"> Turn ON the POT and NOT signals. In the POT and NOT inputs are not used, set them to be disabled.
	The CONTROL mode is not correct.	Check the CONTROL mode Selection (Pn001).	Set the CONTROL mode to match the command type.
	The error counter reset (ECRST) is ON.	In MONITOR mode, check whether the ECRST signal is ON or OFF.	<ul style="list-style-type: none"> Turn OFF the ECRST signal. Wire correctly.
	The COMMAND PULSE mode (Pn007) selection is incorrect.	Check the controller's command pulse type and the Servo Drive's command pulse type.	Set the Servo Drive's pulse type to match the controller's command pulse type.
	The zero speed designation (VZERO) is OFF.	In MONITOR mode, check whether the VZERO signal is ON or OFF.	<ul style="list-style-type: none"> Turn ON the VZERO signal. Wire correctly.
	The internally set speeds are not set.	Check the set value of Pn304 to Pn311.	Set the desired speeds.
	The No. 1 Force Limit (Pn013) or No. 2 Force Limit (Pn522) is set to 0.	Check the set value of Pn013 and Pn522.	Return the set value to the default setting.
	The motor power cable is wired incorrectly.	Check the wiring.	Wire correctly.
	The encoder cable is wired incorrectly.		
The control I/O connector (CN1) is wired incorrectly.	Check the command pulse's wiring.	Wire correctly.	
	Check the command pulse type.	Set the Servo Drive's pulse type to match the controller's command pulse type.	
	Check the command pulse's voltage.	Connect a resistor that matches the voltage.	
The power supply is not ON.	Check whether the power supply is ON and check the PWR LED indicator.	Turn ON the power supply.	
	Check the voltage across the power supply terminals.	Wire the power supply's ON circuit correctly.	
The speed command is disabled.	Check if the speed command method is correct.	<ul style="list-style-type: none"> Set the external analog command correctly. Set the internal speed correctly. 	

Symptom	Probable cause	Items to check	Measures
The motor does not move even if commands are input from the controller. (Continued from previous page)	The force command is disabled.	Check if the force command input method is correct.	Set the force command correctly.
	The CW input and CCW input are ON at the same time.	Check the command pulse's wiring.	<ul style="list-style-type: none"> Input the pulse signal either to the CW input or CCW input. Always turn OFF the terminal that is not input to.
	Servo Drive is faulty.	–	Replace the Servo Drive.
The motor operates momentarily, but then it does not operate after that.	The motor power cable is wired incorrectly.	Check the wiring of the motor power cable's phases U, V, and W.	Wire correctly.
	The encoder cable is wired incorrectly.	Check the encoder cable's wiring.	Wire correctly.
The motor moves without a command.	The command pulse input is incorrect.	Check the command pulse type.	Set the correct command pulse input.
		Check the command pulse's voltage.	Connect a resistor that matches the voltage.
	Servo Drive is faulty.	–	Replace the Servo Drive.
The motor moves in the reverse direction from the command.	The CW input and CCW input connections are reversed.	Check the controller's command pulse type and the Servo Drive's command pulse type.	Connect the CW pulse signal to the CW input and the CCW pulse signal to the CCW input.
Motor movement is unstable.	The motor power cable or encoder cable is wired incorrectly.	Check the wiring of the motor power cable's phases U, V, and W and check the encoder cable's wiring.	Wire correctly.
	The mechanical installation is not rigid enough.	Check the mechanical system design.	Review and adjust the machine.
	The load's mass exceeds the Servo Drive's allowable value.	Try moving the motor without a load. (Disconnect it from the mechanical system.)	<ul style="list-style-type: none"> Reduce the load. Replace the Linear Servomotor and Servo Drive with higher capacity models.
	The pulse signal line's connections are loose.	Check the pulse signal line's wiring at the controller and Servo Drive.	Wire correctly.
		Check the controller's command pulse type and the Servo Drive's command pulse type.	Set the Servo Drive's pulse type to match the controller's command pulse type.
	The gain is wrong.	–	Perform manual tuning.
	The CN1 input signal is chattering.	Check the operation command (RUN), error counter reset (ECRST), zero speed designation (VZERO), internally set speed selection 1 (VSEL1) and internally set speed selection 2 (VSEL2).	Wire correctly so that there is no chattering.

11-4 Troubleshooting

Symptom	Probable cause	Items to check	Measures
The motor is overheating.	The ambient temperature is too high.	Check that the ambient temperature around the motor is 40°C or less.	Lower the ambient temperature around the motor to 40°C or less. (Use a fan or air conditioner.)
	Ventilation is obstructed.	Check to see whether anything is blocking ventilation.	Improve ventilation.
	The motor is overloaded.	Try moving the motor without a load. (Disconnect it from the mechanical system.)	<ul style="list-style-type: none"> · Reduce the load. · Replace the Linear Servomotor and Servo Drive with higher capacity models.
	The motor is vibrating.		
	The moving table attached to the motor coil is too small.	Check the dimensions of the table against the specification.	Increase the size of the table or add extra ventilation.
The motor holding brake is ineffective.	Power is supplied to the holding brake.	Check whether power is supplied to the holding brake.	Configure a circuit that cuts power supply to the holding brake when the motor stops and the load is held by the holding brake.
The motor does not stop or is hard to stop even if the operation command (RUN) is turned OFF while the motor is moving.	The load mass is too large.	Check the following: <ul style="list-style-type: none"> · Is the load too large? · Is the motor movement speed too high? 	Review the load conditions, and replace the Linear Servomotor and Servo Drive with appropriate models.
	The stop circuit failed.	—	Replace the drive.

Symptom	Probable cause	Items to check	Measures
The motor is producing unusual noises or the machine is vibrating.	There are problems with the machine's installation.	Check whether the Linear Servomotor's mounting screws are loose.	Retighten the mounting screws.
	There is a problem with the bearings.	Check for noise or vibration around the bearings.	Contact your OMRON dealer or sales office.
	The gain is wrong.	–	Perform manual tuning.
	The Speed Feedback Filter Time Constant (Pn??) is wrong.	Check the set value of Pn??.	Return the set to 0 (default set) or increase the set value.
	Noise is entering the control I/O signal cable because the cable does not meet specifications.	Check that it is a twisted-pair wire or twisted-pair shielded cable with core wires that are at least 0.08 mm ² .	Use control I/O signal cable that meets specifications.
	Noise is entering the control I/O signal cable because the cable is longer than the specified length.	Check the length of the control I/O signal cable.	Shorten the control I/O signal cable to 3 m or less.
	Noise is entering the cable because the encoder cable does not meet specifications.	Check that it is a twisted-pair shielded cable with core wires that are at least 0.12 mm ² .	Use encoder cable that meets specifications.
	Noise is entering the encoder cable because the cable is longer than the specified length.	Check the length of the encoder cable.	Shorten the encoder cable to less than 50 m.
	Noise is entering the signal lines because the encoder cable is stuck or the sheath is damaged.	Check the encoder cable for damage.	Correct the encoder cable's pathway.
	Too much noise is entering the encoder cable.	Check whether the encoder cable is bound together with or too close to high-current lines.	Install the encoder cable where it won't be subjected to surges.
	The FG's potential is fluctuating due to devices near the Linear Servomotor, such as welding machines.	Check for ground problems (loss of ground or incomplete ground) at equipment such as welding machines near the Linear Servomotor.	Ground the equipment properly and prevent currents from flowing to the encoder FG.
	Errors are being caused by excessive vibration or shock on the encoder.	There are problems with mechanical vibration or motor installation (such as the precision of the mounting surface, attachment, or axial offset).	Reduce the mechanical vibration or correct the Linear Servomotor's installation.
The machine and the motor are resonating.	Check whether the machine is resonating.	<ul style="list-style-type: none"> Readjust the force command filter time constant. If there is resonance, set the Notch Filter 1 Frequency (Pn201), Notch Filter 1 Width (Pn202), and Notch Filter 1 Depth (Pn203). 	
Vibration is occurring at the same frequency as the power supply.	Inductive noise is occurring.	Check whether the drive control signal lines are too long.	Shorten the control signal lines.
		Check whether the control signal lines and power supply lines are not bound together.	<ul style="list-style-type: none"> Separate control signal lines from power supply lines. Use a low-impedance power supply for control signals.

11-4 Troubleshooting

Symptom	Probable cause	Items to check	Measures
The position is misaligned. (Position misalignment occurs without an alarm being output.)	There is an error in the coupling of the mechanical system and the Linear Servomotor.	Check whether the coupling of the mechanical system and the Linear Servomotor is misaligned.	Correct the coupling between the mechanical system and the Linear Servomotor.
	Noise is entering the error counter reset (ECRST).	Check whether the control signal lines and power supply lines are not bound together.	Separate the control signal lines from the power lines or take other measures against noise.
	The gain is wrong.	–	Perform manual tuning.
	The load mass is large.	Inspect the following. <ul style="list-style-type: none"> · Is the load too large? · Is the motor movement speed too high? 	<ul style="list-style-type: none"> · Adjust the gain. · Review the load conditions, and replace the Linear Servomotor and Servo Drive with appropriate models.

11-5 Periodic Maintenance



Caution



After replacing the unit, transfer to the new unit all data needed to resume operation, before restarting the operation. Equipment damage may result.



Never repair the product by disassembling it. Electric shock or injury may result.

Linear Servomotors and Servo Drives contain many components and will operate properly only when each of the individual components is operating properly. Some of the electrical and mechanical components require maintenance depending on application conditions. Periodic inspection and replacement are necessary to ensure proper long-term operation of Linear Servomotors and Servo Drives. (Quotes from The Recommendation for Periodic Maintenance of a General-purpose Inverter published by JEMA.)

The periodic maintenance cycle depends on the installation environment and application conditions of the Linear Servomotors and Servo Drives. Recommended maintenance times are listed below for Linear Servomotors and Servo Drives. Use these for reference in periodic maintenance.

Linear Servomotor Limit

- ◆ The Linear Servomotors have not friction or moving parts by themselves so, there is no maintenance actions for the motor itself.
- ◆ But the complete installation needs some maintenance:
 - The motor cables are moving. The lifetime of the standard cables are 10000000 bending operations with a bending radius of 10 times the cable diameter. Replace the cables after that number of operations.
 - The linear bearings are selected for a certain lifetime based on the installation conditions, load and movement cycle. Replace the linear bearings and guides when lifetime has expired.
 - Grease the linear bearings according to the maker's recommendation.

Servo Drive Limit

- ♦ The lifetime for the different drive parts is listed below.
Aluminum electrolytic capacitors: 28,000 hours
(at an ambient drive operating temperature of 55°C, constant output of rated force, constant output of rated movement speed, and installation as described in this manual)
Axial-flow fan: 10,000 to 30,000 hours (The limit depends on the operating conditions.)
Inrush current prevention relay: Approx. 20,000 operations (The limit depends on the operation conditions.)
- ♦ When using the drive in continuous operation, use fans or air conditioners to maintain an ambient temperature below 40°C.
- ♦ We recommend that ambient temperature and the power supply ON time be reduced as much as possible to lengthen the service life of the drive.
- ♦ The limit of aluminum electrolytic capacitors is greatly affected by the ambient operating temperature. Generally, an increase of 10°C in the operating ambient temperature will reduce capacitor limit by 50%. Following equation shows an example for 25°C: .

$$\text{Lifetime}_{25^{\circ}\text{C}} = \text{Lifetime}_{55^{\circ}\text{C}} \times 2^{\frac{55-25}{10}} = 224000 \text{ hours}$$

- ♦ The aluminum electrolytic capacitors deteriorate even when the Servo Drive is stored with no power supplied. If the drive is not used for a long time, we recommend a periodic inspection and replacement schedule of 5 years.
- ♦ If the Linear Servomotor or Servo Drive is not to be used for a long time, or if they are to be used under conditions worse than those described above, a periodic inspection schedule of 5 years is recommended.

Upon request, OMRON will examine the Servo Drive and Linear Servomotor and determine if a replacement is required.

12

Appendix

This chapter provides connection examples using OMRON's PLC and Position Controller, a list of parameters and Safety Certification.

12-1 Connection Examples	12-2
12-2 Parameter List.....	12-12
12-3 Safety Certification	12-37

12-1 Connection Examples

Connection Example 1: Connecting to SYSMAC CJ1W-NC133/233/433

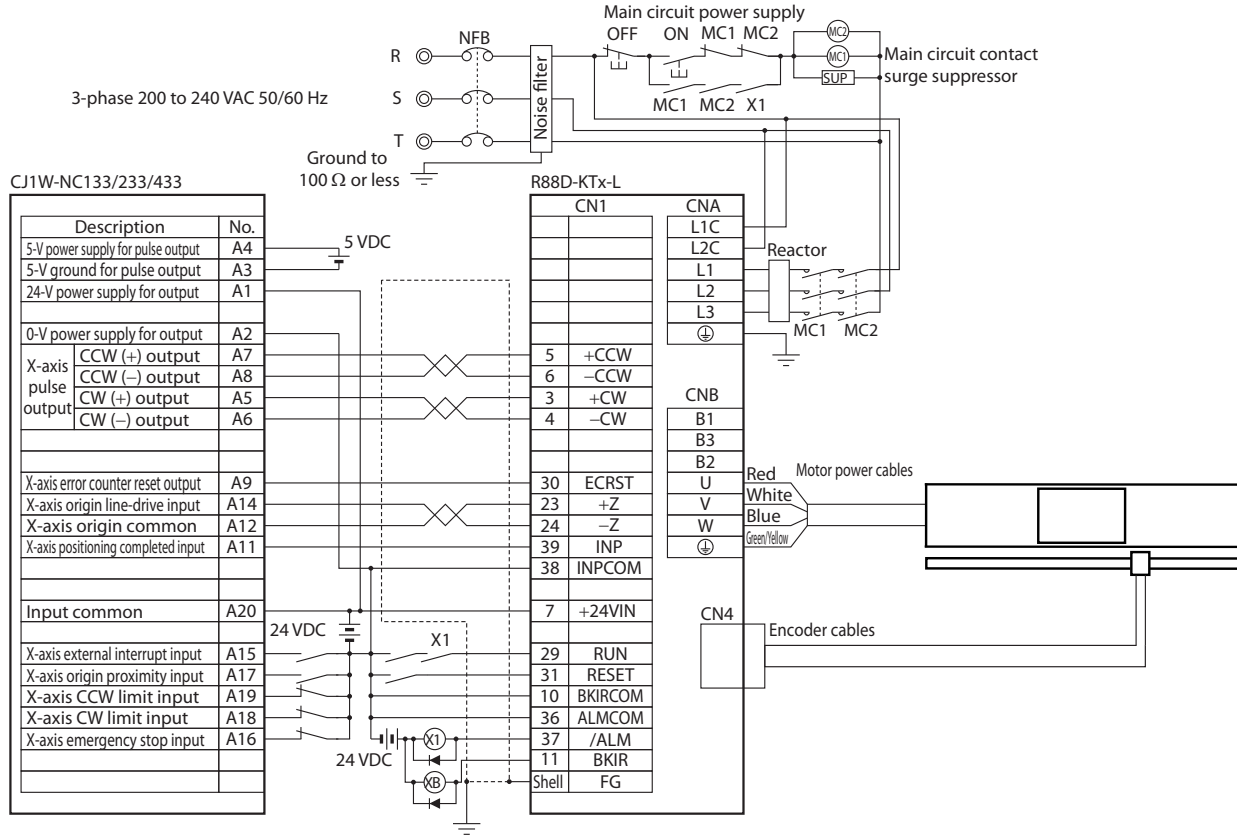

Precautions for Correct Use

- The example shows a 3-phase, 200-VAC input to the drive for the main circuit power supply. Be sure to provide a power supply and wiring conforming to the power supply specifications for the drive in use.
- Incorrect signal wiring can cause damage to units and the drive.
- Leave unused signal lines open and do not wire them.
- Use mode 2 for origin search.
- The diode recommended for surge absorption is the RU 2 (Sanken Electric Co., Ltd.) or the equivalent.
- Make the setting so that the servo can be turned ON/OFF with the RUN signal.

Connection Example 2: Connecting to SYSMAC CJ1W-NC113/213/413

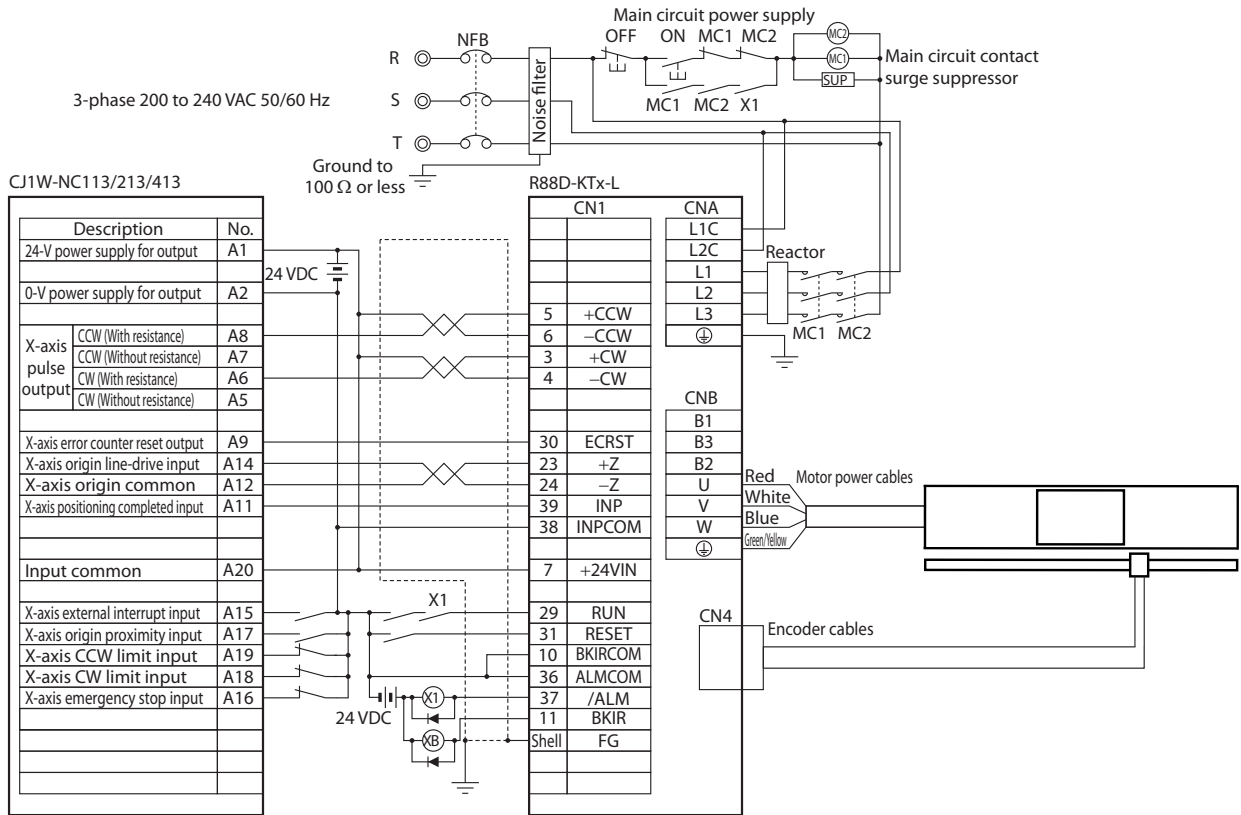

⚡ Precautions for Correct Use

- The example shows a 3-phase, 200-VAC input to the drive for the main circuit power supply. Be sure to provide a power supply and wiring conforming to the power supply specifications for the drive in use.
- Incorrect signal wiring can cause damage to units and the drive.
- Leave unused signal lines open and do not wire them.
- Use mode 2 for origin search.
- The diode recommended for surge absorption is the RU 2 (Sanken Electric Co., Ltd.) or the equivalent.
- Make the setting so that the servo can be turned ON/OFF with the RUN signal.

Connection Example 3: Connecting to SYSMAC CS1W-NC133/233/433

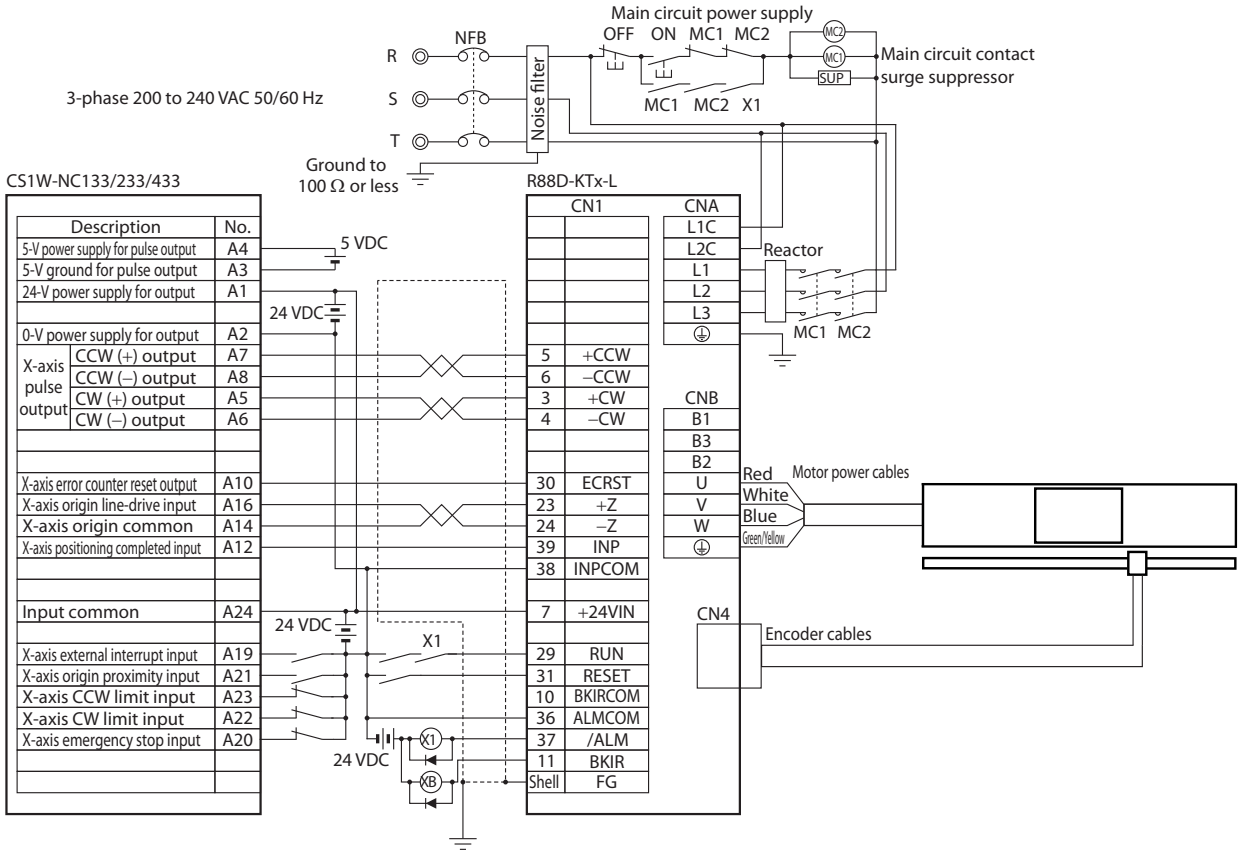

Precautions for Correct Use

- The example shows a 3-phase, 200-VAC input to the drive for the main circuit power supply. Be sure to provide a power supply and wiring conforming to the power supply specifications for the drive in use.
- Incorrect signal wiring can cause damage to units and the drive.
- Leave unused signal lines open and do not wire them.
- Use mode 2 for origin search.
- The diode recommended for surge absorption is the RU 2 (Sanken Electric Co., Ltd.) or the equivalent.
- Make the setting so that the servo can be turned ON/OFF with the RUN signal.

Connection Example 4: Connecting to SYSMAC CS1W-NC113/213/413 or C200HW-NC113/213/413

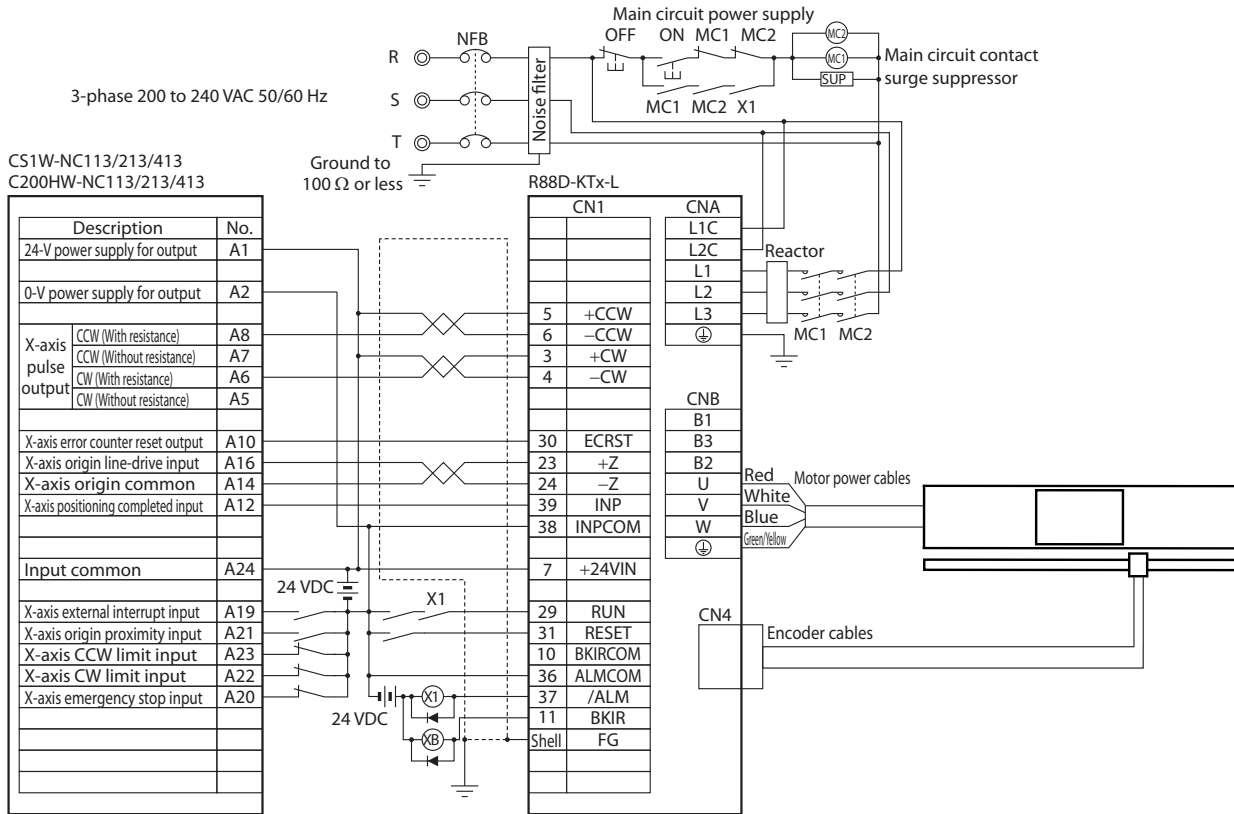

Precautions for Correct Use

- The example shows a 3-phase, 200-VAC input to the drive for the main circuit power supply. Be sure to provide a power supply and wiring conforming to the power supply specifications for the drive in use.
- Incorrect signal wiring can cause damage to units and the drive.
- Leave unused signal lines open and do not wire them.
- Use mode 2 for origin search.
- The diode recommended for surge absorption is the RU 2 (Sanken Electric Co., Ltd.) or the equivalent.
- Make the setting so that the servo can be turned ON/OFF with the RUN signal.

Connection Example 5: Connecting to a SYSMAC Motion Control Unit

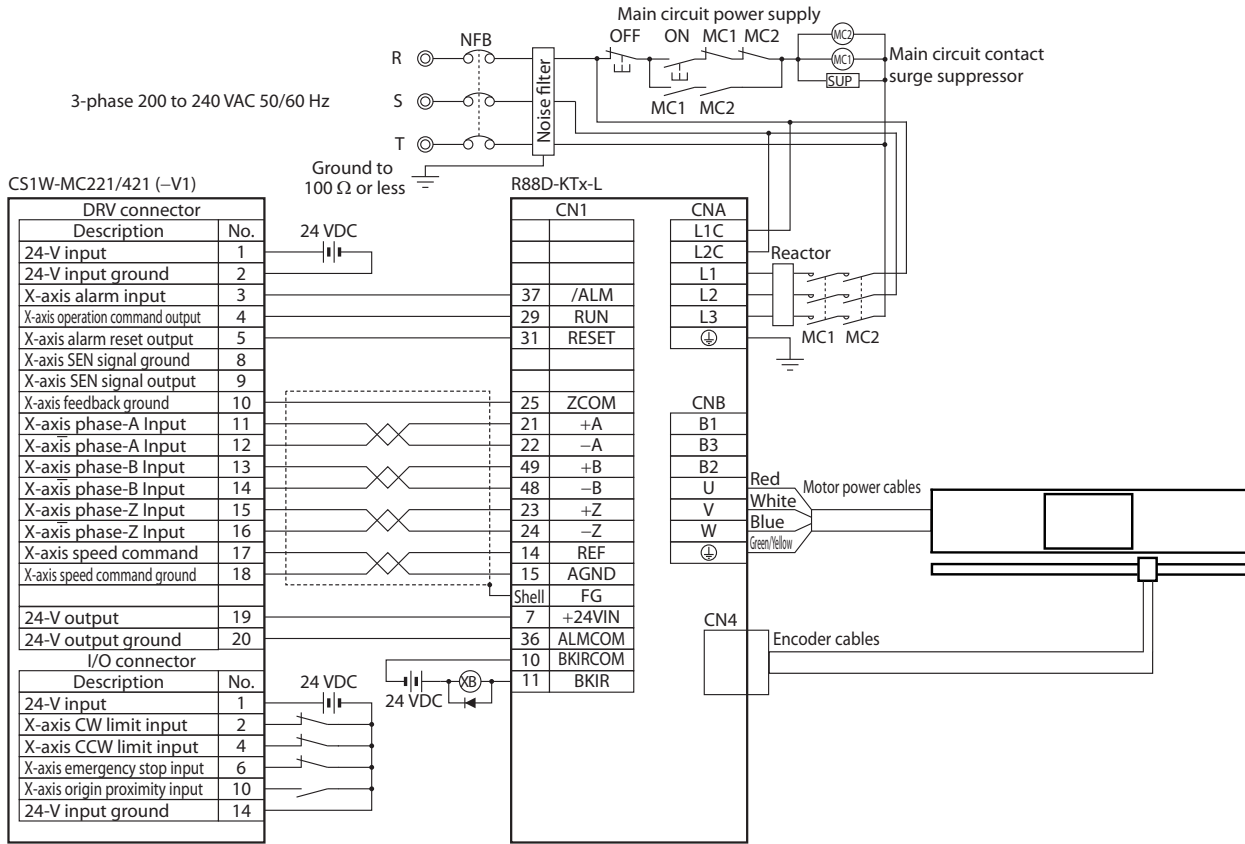

Precautions for Correct Use

- The example shows a 3-phase, 200-VAC input to the drive for the main circuit power supply. Be sure to provide a power supply and wiring conforming to the power supply specifications for the drive in use.
- Incorrect signal wiring can cause damage to units and the drive.
- Leave unused signal lines open and do not wire them.
- Connect terminals and wiring marked with an asterisk (*) when using an absolute encoder.
- This wiring diagram is an example of X-axis wiring only. For other axes, connections must be made in the same way with the drive.
- Always short unused NC input terminals at the Motion Control Unit I/O connectors.
- Make the setting so that the servo can be turned ON/OFF with the RUN signal.

Connection Example 6: Connecting to SYSMAC CP1H-YxxDT-D

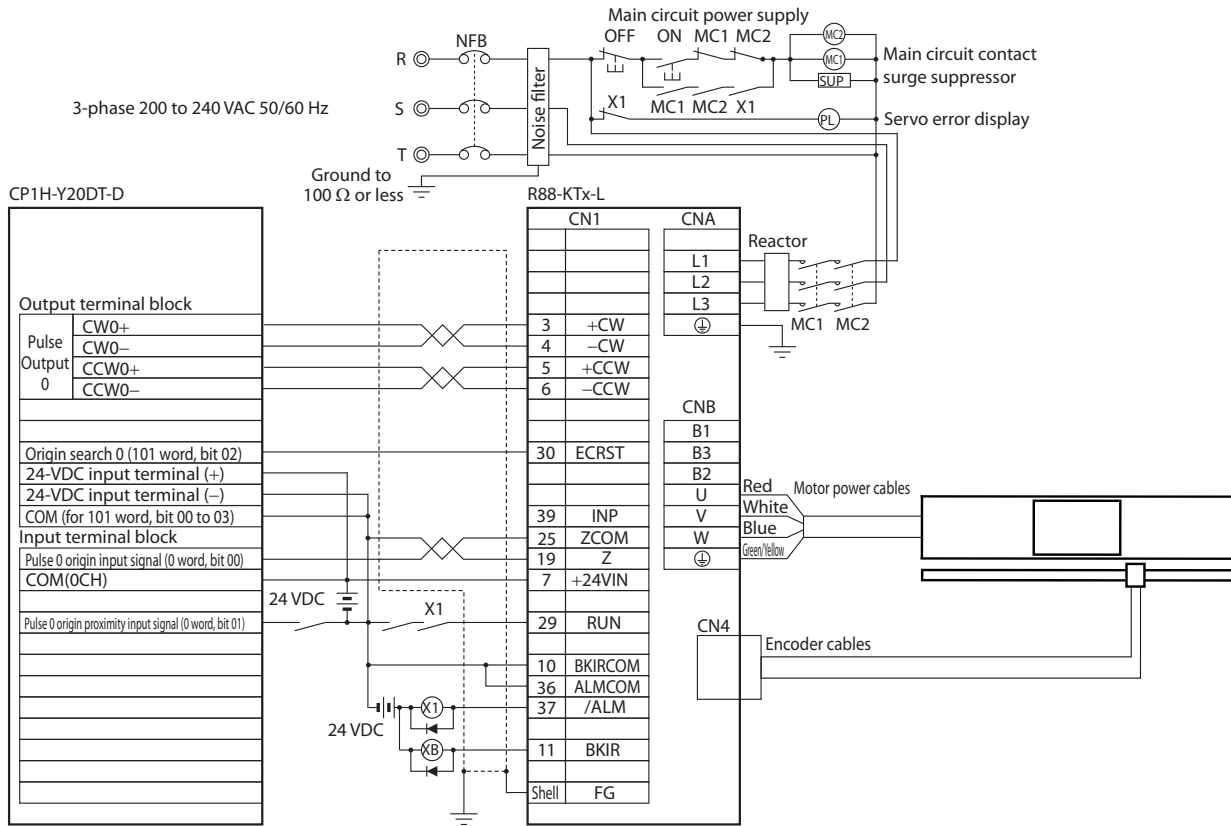

Precautions for Correct Use

- Incorrect signal wiring can cause damage to units and the drive.
- Leave unused signal lines open and do not wire them.
- Do not share the power supply for brakes (24 VDC) with the 24-VDC power supply for controls.
- The diode recommended for surge absorption is the RU 2 (Sanken Electric Co., Ltd.) or the equivalent.

Connection Example 7: Connecting to SYSMAC CP1H-XxxDT-D/CP1L-xxxDT-D

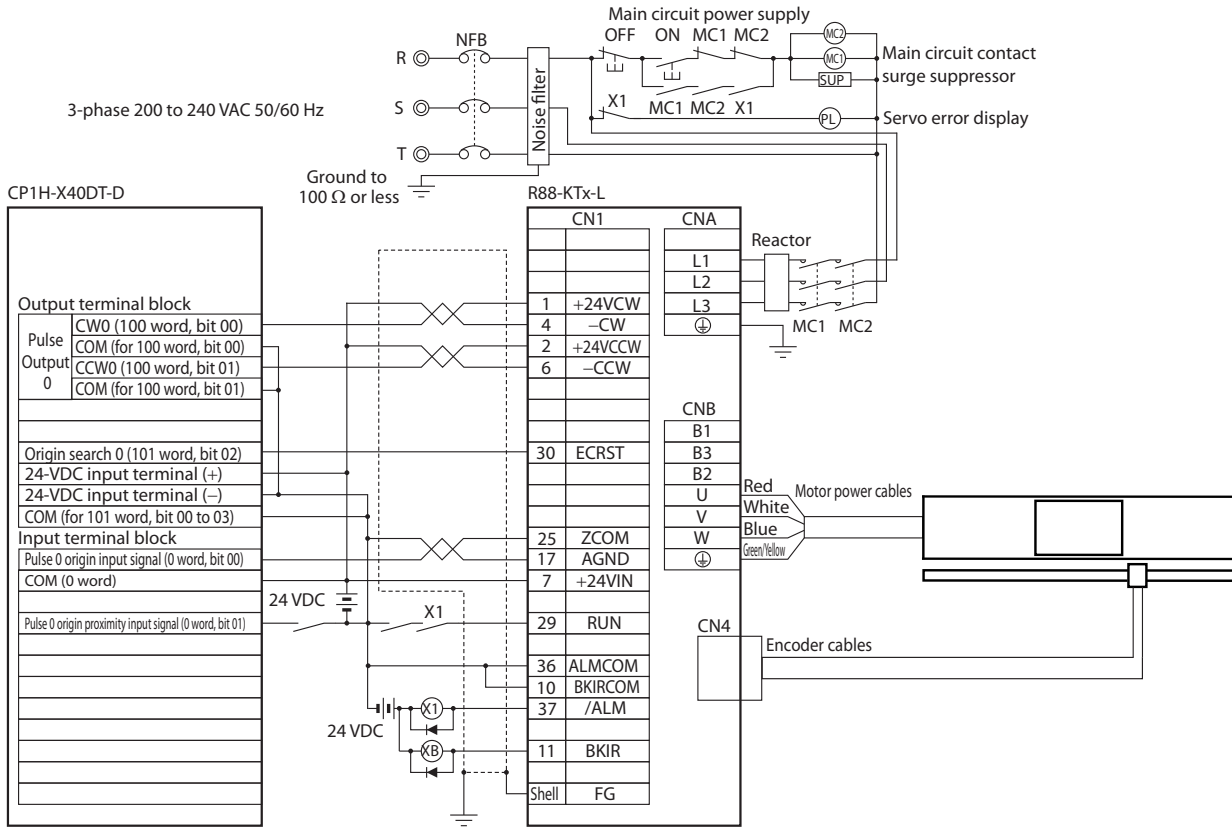

Precautions for Correct Use

- ♦ Incorrect signal wiring can cause damage to units and the drive.
- ♦ Leave unused signal lines open and do not wire them.
- ♦ Do not share the power supply for brakes (24 VDC) with the 24-VDC power supply for controls.
- ♦ The diode recommended for surge absorption is the RU 2 (Sanken Electric Co., Ltd.) or the equivalent.

Connection Example 8: Connecting to SYSMAC CJ1M

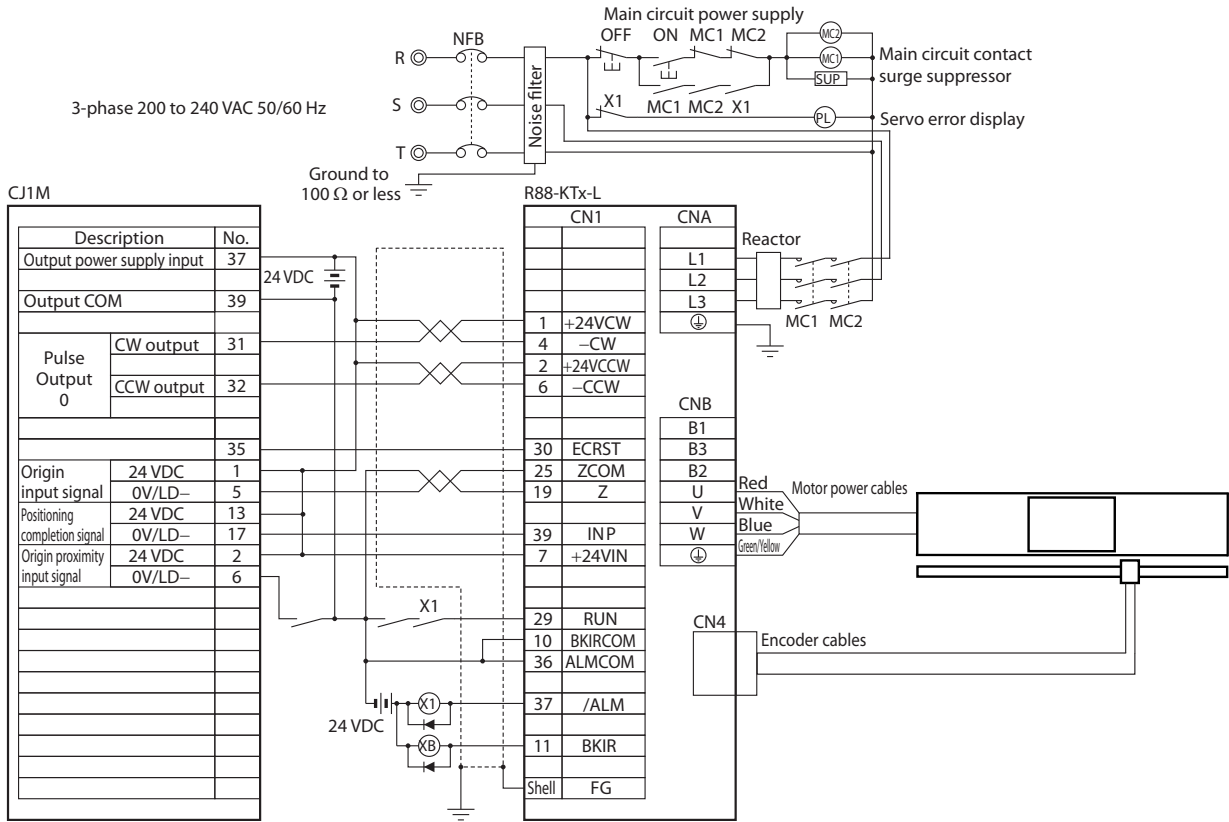

Precautions for Correct Use

- ◆ Incorrect signal wiring can cause damage to units and the drive.
- ◆ Leave unused signal lines open and do not wire them.
- ◆ Use mode 2 for origin search.
- ◆ Use the power supply for command pulse (24 VDC) as a dedicated power supply.
- ◆ Do not share the power supply for brakes (24 VDC) with the 24-VDC power supply for controls.
- ◆ The diode recommended for surge absorption is the RU 2 (Sanken Electric Co., Ltd.) or the equivalent.

**Connection Example 9:
Connecting to a SYSMAC CS1W-HCP22-V1 Customizable Counter Unit**

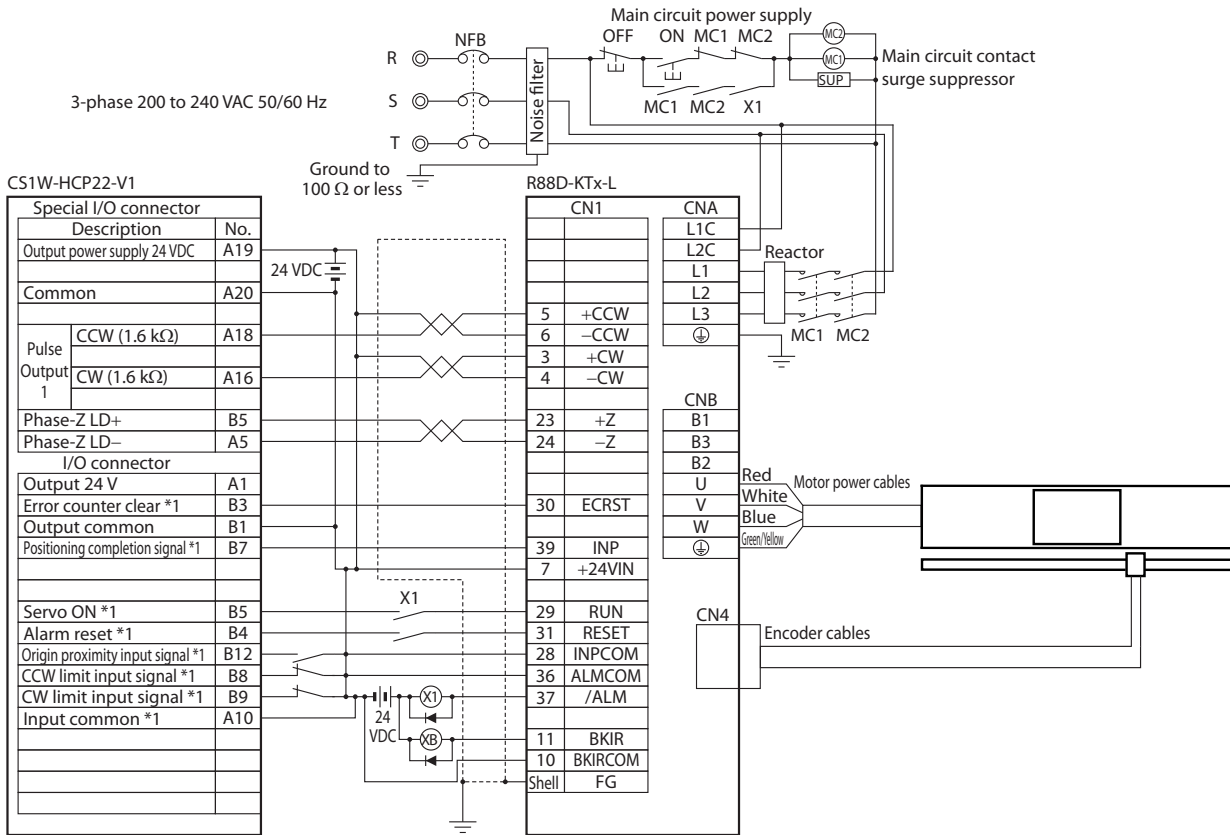

*1. The I/O signals for the HCP22 depend on the memory allocations in the Internal Memory area. Change the wiring according to the allocations.

Precautions for Correct Use

- ◆ Incorrect signal wiring can cause damage to units and the drive.
- ◆ Leave unused signal lines open and do not wire them.
- ◆ Use the power supply for command pulse (24 VDC) as a dedicated power supply.
- ◆ The diode recommended for surge absorption is the RU 2 (Sanken Electric Co., Ltd.) or the equivalent.
- ◆ Do not share the power supply for brakes (24 VDC) with the 24-VDC power supply for controls.

**Connection Example 10:
Connecting to a SYSMAC CS1W-HCA12/22-V1 Customizable Counter Unit**

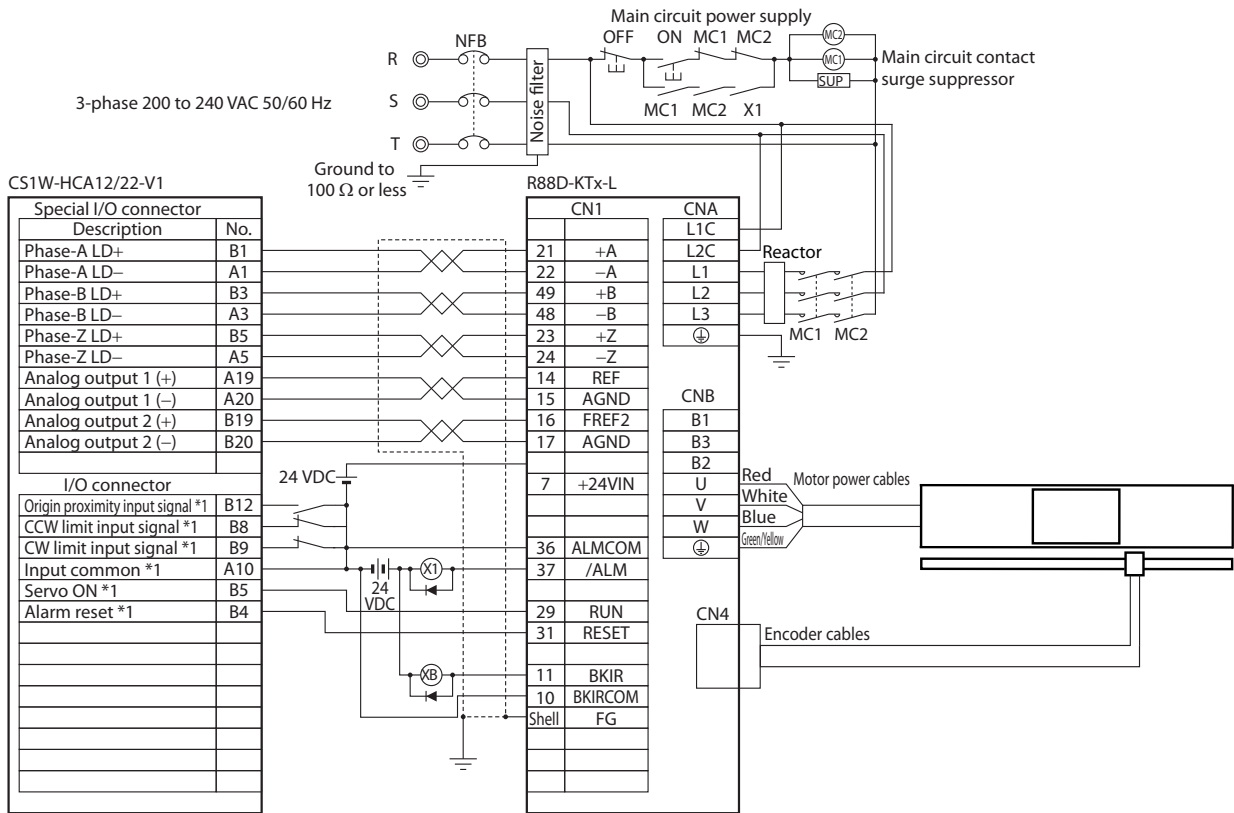

*1. The I/O signals for the HCA12/22 depend on the allocations in the Internal Memory area. Change the wiring according to the allocations.

Precautions for Correct Use

- Incorrect signal wiring can cause damage to units and the drive.
- Leave unused signal lines open and do not wire them.
- Use the power supply for command pulse (24 VDC) as a dedicated power supply.
- The diode recommended for surge absorption is the RU 2 (Sanken Electric Co., Ltd.) or the equivalent.
- Do not share the power supply for brakes (24 VDC) with the 24-VDC power supply for controls.

12-2 Parameter List

- ♦ Some parameters are enabled by turning the power supply OFF and then ON again. (Those parameters are indicated in the table.) After changing these parameters, turn OFF the power supply, confirm that the power supply indicator has gone OFF, and then turn ON the power supply again.
- ♦ Do not change the parameters marked "Reserved". Do not change the settings marked "Reserved".

Basic Setting Parameters

Pn number	Parameter name	Setting	Explanation	Default setting	Unit	Setting range	Power supply OFF to ON
000	Movement Direction Switching		Set the relation between the command direction and the motor movement direction.	1	-	0 to 1	Yes
		0	The +command indicates the forward direction as viewed from the shaft end (CW).				
		1	The +command indicates the reverse direction as viewed from the shaft end (CCW).				
001	CONTROL mode Selection		Select the drive CONTROL mode.	0	-	0 to 5	Yes
		0	Position control (pulse train command)				
		1	Speed control (analog command)				
		2	Force control (analog command)				
		3	No. 1: Position control No. 2: Speed control				
		4	No. 1: Position control No. 2: Force control				
5	No. 1: Speed control No. 2: Force control						
002	REALTIME AUTOTUNING mode selection		Set the OPERATION mode for realtime autotuning.	1	-	0 to 6	-
		0	Disabled				
		1	Emphasizes stability				
		2	Emphasizes positioning				
		3	If there is an unbalanced load like in a vertical axis.				
		4	When friction is large (unbalanced load is estimated also).				
		5	Monitor mode in combination with the tool				
6	Tuning where you can select the applied algorithms with Pn632.						
003	Realtime Autotuning Machine Rigidity Setting		Set the machine rigidity for executing realtime autotuning.	See Note 1	-	0 to 31	-
004	Mass Ratio		Set the load mass as a percentage of the motor rotor mass.	250	%	0 to 10,000	-

Pn number	Parameter name	Setting	Explanation	Default setting	Unit	Setting range	Power supply OFF to ON
005	Command Pulse Input Selection		Select the command pulse input.	0	-	0 to 1	Yes
		0	Photocoupler input				
		1	Input for line drive only				
006	Command Pulse Movement Direction Switching Selection		Set the command pulse count direction.	0	-	0 to 1	Yes
		0	Forward direction				
		1	Reverse direction				
007	COMMAND PULSE mode Selection		Set the COMMAND PULSE mode.	1	-	0 to 3	Yes
		0	90° phase difference (A/B) signal inputs.				
		1	Forward pulse/reverse pulse.				
		2	90° phase difference (A/B) signal inputs.				
		3	Feed pulse/direction signal.				
009	Electronic Ratio Numerator 1		Set the electronic ratio. $\frac{\text{Electronic ratio numerator 1 (Pn009)}}{\text{Electronic ratio denominator (Pn010)}}$	10000	-	1 to 1073741824	-
010	Electronic Ratio Denominator			10000	-	1 to 1073741824	-
011	Encoder Dividing Numerator		Set the number of phase A and phase B output pulses per every Pn503 pulses of the motor encoder. $\text{Output_pulses} = \text{encoder_pulses} \times \frac{\text{Pn011}}{\text{Pn503}}$	2500	-	1 to 262,144	Yes
012	Encoder Output Direction Switching Selection		Select the phase B logic for pulse regeneration output and the output source.	0	-	0 to 3	Yes
		0,2	Phase B logic: Not reversed				
		1,3	Phase B logic: Reversed				
013	No. 1 Force Limit		Set the No. 1 limit value for the output force of the motor.	500	%	0 to 500	-
014	Error Counter Overflow Level		Set the range of the error counter overflow level. Detection of error counter overflow level error will be disabled if the set value is 0.	100000	Command unit	0 to 134217728	-

12-2 Parameter List

Pn number	Parameter name	Setting	Explanation	Default setting	Unit	Setting range	Power supply OFF to ON
016	Regeneration Resistor Selection		Select the Regeneration Resistor used.	See Note 2	-	0 to 3	Yes
		0	Use the Built-in Resistor. Triggering of regeneration overload protection (alarm display No. 18) depends on the Built-in Resistor (with approx. 1% duty).				
		1	Use an External Resistor. The regeneration processing circuit operates and regeneration overload protection (alarm display No. 18) is triggered when the operating rate of the Regeneration Resistor exceeds 10%.				
		2	Use an External Resistor. Regeneration overload protection (alarm display No. 18) does not operate.				
		3	No Regeneration Resistor. All regeneration power is processed with built-in capacitors.				
017	External Regeneration Resistor Setting		Select the type of load ratio calculation for the External Regeneration Resistor.	0	-	0 to 4	Yes
		0	Regeneration load ratio is 100% when operating rate of the External Regeneration Resistor is 10%.				
		1	Reserved				
		2	Reserved				
		3	Reserved				
		4	Reserved				

♦Note 1: Pn003 default settings:

- (1) Pn003 = 11 - For 200V drives of 1Kw or upper and 400V drives
- (2) Pn003 = 13 - For 200V drives of less than 1 Kw

♦Note 2: Pn016 default settings:

- (1) Pn016 = 0 - For 200V drives of 750 W or upper and 400V drives
- (2) Pn016 = 3 - For 200V drives of less than 750 W

Gain Adjustment Parameters

Pn number	Parameter name	Setting	Explanation	Default setting	Unit	Setting range	Power supply OFF to ON
100	Position Loop Gain		Set the position loop gain 1.	See Note 1	0.1/s	0 to 30,000	-
101	Speed Loop Gain		Set the speed loop gain 1.	See Note 2	0.1 Hz	1 to 32,767	-
102	Speed Loop Integral Time Constant		Set the speed loop integration time constant 1.	See Note 3	0.1 ms	1 to 10,000	-

Pn number	Parameter name	Setting	Explanation	Default setting	Unit	Setting range	Power supply OFF to ON
103	Speed Feedback Filter Time Constant		The speed feedback filter 1 can be set to one of 6 values.	0	–	0 to 5	–
104	Force Command Filter Time Constant		Set the time constant for the force filter 1.	See Note 4	0.01 ms	0 to 2,500	–
105	Position Loop Gain2		Set the position loop gain 2.	See Note 5	0.1/s	1 to 30,000	–
106	Speed Loop Gain 2		Set the speed loop gain 2.	See Note 6	0.1 Hz	1 to 32,767	–
107	Speed Loop Integration Time Constant 2		Set the speed loop integration time constant 2.	10000	0.1 ms	1 to 10,000	–
108	Speed Feedback Filter Time Constant 2		The speed feedback filter 2 can be set to one of 6 values.	0	–	0 to 5	–
109	Force Command Filter Time Constant 2		Set the time constant for the force filter 2.	See Note 7	0.01 ms	0 to 2,500	–
110	Speed Feed-forward Amount		Set the speed feed-forward amount.	300	0.1%	0 to 1,000	–
111	Speed Feed-forward Command Filter		Set the speed feed-forward filter time constant.	50	0.01 ms	0 to 6,400	–
112	Force Feed-forward Amount		Set the force feed-forward amount.	0	0.1%	0 to 1,000	–
113	Force Feed-forward Command Filter		Set the force feed-forward filter.	0	0.01 ms	0 to 6,400	–
114	GAIN SWITCHING INPUT OPERATING mode Selection		Execute optimum tuning using the gain switching function.	1	–	0 to 1	–
		0	Gain 1 (PI/P switching enabled)				
		1	Gain 1 and gain 2 switching available				

12-2 Parameter List

Pn number	Parameter name	Setting	Explanation	Default setting	Unit	Setting range	Power supply OFF to ON
115	SWITCHING mode in Position Control		Select the gain switching condition for position control. It is necessary that Pn114 be set to 1.	0	-	0 to 10	-
		0	Always gain 1				
		1	Always gain 2				
		2	Switching using gain switching input (GSEL)				
		3	Force command				
		4	Always gain 1				
		5	Command speed				
		6	Amount of position error				
		7	Command pulses received				
		8	Positioning completion signal (INP) OFF				
		9	Actual motor speed				
10	Combination of command pulse input and speed						
116	Gain Switching Delay Time in Position Control		Set the delay time for switching from gain 2 to gain 1.	50	0.1 ms	0 to 10,000	-
117	Gain Switching Level in Position Control		Set the gain switching level.	50	-	0 to 20,000	-
118	Gain Switching Hysteresis in Position Control		Set the hysteresis for gain switching.	33	-	0 to 20,000	-
119	Position Gain Switching Time		Set the position gain switching time for gain switching.	33	0.1 ms	0 to 10,000	-
120	SWITCHING mode in Speed Control		Select the gain switching condition for speed control. It is necessary that Pn114 be set to 1.	0	-	0 to 5	-
		0	Always gain 1				
		1	Always gain 2				
		2	Switching using gain switching input (GSEL)				
		3	Force command				
		4	Speed command change amount				
5	Command speed						
121	Gain Switching Delay Time in Speed Control		Set the delay time for switching from gain 2 to gain 1.	0	0.1 ms	0 to 10,000	-
122	Gain Switching Level in Speed Control		Set the gain switching level.	0	-	0 to 20,000	-
123	Gain Switching Hysteresis in Speed Control		Set the hysteresis for gain switching.	0	-	0 to 20,000	-

Pn number	Parameter name	Setting	Explanation	Default setting	Unit	Setting range	Power supply OFF to ON
124	SWITCHING mode in Force Control		Select the gain switching condition for force control. It is necessary that Pn114 be set to 1.	0	-	0 to 3	-
		0	Always gain 1				
		1	Always gain 2				
		2	Switching using gain switching input (GSEL)				
		3	Force command				
125	Gain Switching Delay Time in Force Control		Set the delay time for switching from gain 2 to gain 1.	0	0.1 ms	0 to 10,000	-
126	Gain Switching Level in Force Control		Set the gain switching level.	0	-	0 to 20,000	-
127	Gain Switching Hysteresis in Force Control		Set the hysteresis for gain switching.	0	-	0 to 20,000	-

♦Note 1: Pn100 default settings:

- (1) Pn100 = 320 - For 200V drives of 1Kw or upper and 400V drives
- (2) Pn100 = 480 - For 200V drives of less than 1 Kw

♦Note 2: Pn101 default settings:

- (1) Pn101 = 180 - For 200V drives of 1Kw or upper and 400V drives
- (2) Pn101 = 270 - For 200V drives of less than 1 Kw

♦Note 3: Pn102 default settings:

- (1) Pn102 = 310 - For 200V drives of 1Kw or upper and 400V drives
- (2) Pn102 = 210 - For 200V drives of less than 1 Kw

♦Note 4: Pn104 default settings:

- (1) Pn104 = 126 - For 200V drives of 1Kw or upper and 400V drives
- (2) Pn104 = 84 - For 200V drives of less than 1 Kw

♦Note 5: Pn105 default settings:

- (1) Pn105 = 380 - For 200V drives of 1Kw or upper and 400V drives
- (2) Pn105 = 570 - For 200V drives of less than 1 Kw

♦Note 6: Pn106 default settings:

- (1) Pn106 = 180 - For 200V drives of 1Kw or upper and 400V drives
- (2) Pn106 = 270 - For 200V drives of less than 1 Kw

♦Note 7: Pn109 default settings:

- (1) Pn109 = 126 - For 200V drives of 1Kw or upper and 400V drives
- (2) Pn109 = 84 - For 200V drives of less than 1 Kw

Vibration Suppression Function Parameters

Pn number	Parameter name	Setting	Explanation	Default setting	Unit	Setting range	Power supply OFF to ON
200	Adaptive Filter Selection	Set the operation of the adaptive filter.		0	-	0 to 4	-
		0	Disabled				
		1	1 enabled. Frequency limited after adaptation.				
		2	2 enabled. Frequency limited after adaptation.				
		3	1 enabled. Adaptation performed at all times.				
		4	2 enabled. Adaptation performed with 1 filter at all times.				
201	Notch 1 Frequency Setting	Set the notch frequency of resonance suppression notch filter 1.		5000	Hz	50 to 5,000	-
202	Notch 1 Width Setting	Set the notch width of the resonance suppression notch filter 1.		2	-	0 to 20	-
203	Notch 1 Depth Setting	Set the notch depth of resonance suppression notch filter 1.		0	-	0 to 99	-
204	Notch 2 Frequency Setting	Set the notch frequency of resonance suppression notch filter 2.		5000	Hz	50 to 5,000	-
205	Notch 2 Width Setting	Set the notch width of the resonance suppression notch filter 2.		2	-	0 to 20	-
206	Notch 2 Depth Setting	Set the notch depth of resonance suppression notch filter 2.		0	-	0 to 99	-
207	Notch 3 Frequency Setting	Set the notch frequency of resonance suppression notch filter 3. This is set automatically when an adaptive notch is enabled.		5000	Hz	50 to 5,000	-
208	Notch 3 Width Setting	Set the notch width of the resonance suppression notch filter 3. This is set automatically when an adaptive notch is enabled.		2	-	0 to 20	-
209	Notch 3 Depth Setting	Set the notch depth of resonance suppression notch filter 3. This is set automatically when an adaptive notch is enabled.		0	-	0 to 99	-
210	Notch 4 Frequency Setting	Set the notch frequency of resonance suppression notch filter 4. This is set automatically when an adaptive notch is enabled.		5000	Hz	50 to 5,000	-
211	Notch 4 Width Setting	Set the notch width of the resonance suppression notch filter 4. This is set automatically when an adaptive notch is enabled.		2	-	0 to 20	-
212	Notch 4 Depth Setting	Set the notch depth of resonance suppression notch filter 4. This is set automatically when an adaptive notch is enabled.		0	-	0 to 99	-

Pn number	Parameter name	Setting	Explanation	Default setting	Unit	Setting range	Power supply OFF to ON
213	Vibration Filter Selection	Select the vibration filter switching method.		0	-	0 to 3	-
		0	Enabled				
		1	When VS-SEL1 input open: Vibration filter 1 and 3 enabled When VS-SEL1 input shorted: Vibration filter 2 and 4 enabled				
		2	When VS-SEL1 open and VS-SEL2 open: Vibration filter 1 enabled When VS-SEL1 shorted and VS-SEL2 open: Vibration filter 2 enabled When VS-SEL1 open and VS-SEL2 shorted: Vibration filter 3 enabled When VS-SEL1 shorted and VS-SEL2 shorted: Vibration filter 4 enabled				
3	Forward direction: Vibration filter 1 and 3 enabled Reverse direction: Vibration filter 2 and 4 enabled						
214	Vibration Frequency 1	Set the vibration frequency 1. The function is enabled if the set value is 10 (= 1 Hz) or greater.		0	0.1 Hz	0 to 2,000	-
215	Vibration Filter 1 Setting	Finely adjust damping control function 1. If force saturation occurs, lower this setting; to increase responsiveness, raise this setting.		0	0.1 Hz	0 to 1,000	-
216	Vibration Frequency 2	Set the vibration frequency 2. The function is enabled if the set value is 10 (= 1 Hz) or greater.		0	0.1 Hz	0 to 2,000	-
217	Vibration Filter 2 Setting	Finely adjust damping control function 2. If force saturation occurs, lower this setting; to increase responsiveness, raise this setting.		0	0.1 Hz	0 to 1,000	-
218	Vibration Frequency 3	Set the vibration frequency 3. The function is enabled if the set value is 10 (= 1 Hz) or greater.		0	0.1 Hz	0 to 2,000	-
219	Vibration Filter 3 Setting	Finely adjust damping control function 3. If force saturation occurs, lower this setting; to increase responsiveness, raise this setting.		0	0.1 Hz	0 to 1,000	-
220	Vibration Frequency 4	Set the vibration frequency 4. The function is enabled if the set value is 10 (= 1 Hz) or greater.		0	0.1 Hz	0 to 2,000	-
221	Vibration Filter 4 Setting	Finely adjust damping control function 4. If force saturation occurs, lower this setting; to increase responsiveness, raise this setting.		0	0.1 Hz	0 to 1,000	-
222	Position Command Filter Time Constant	Set the time constant of the first-order lag filter for the position command.		0	0.1 ms	0 to 10,000	-
223	Smoothing Filter Time Constant	Set the time constant of the FIR filter for the position command.		0	0.1 ms	0 to 10,000	-

Speed and Force Control Parameters

Pn number	Parameter name	Setting	Explanation	Default setting	Unit	Setting range	Power supply OFF to ON
300	Command Speed Selection		Select the speed command when using speed control.	0	-	0 to 3	-
		0	Analog speed command				
		1	No. 1 Internally Set Speed to No. 4 Internally Set Speed (Pn304 to Pn307)				
		2	No. 1 Internally Set Speed to No. 4 Internally Set Speed (Pn304 to Pn306), analog speed command				
		3	No. 1 Internally Set Speed to No. 8 Internally Set Speed (Pn304 to Pn311)				
301	Speed Command Direction Selection		Select the motor for designating the direction for the speed comand.	0	-	0 to 1	-
		0	By analogue command polarity				
		1	By digital input VSIGN				
302	Speed Command Scale		Set the input gain for the analog speed command input.	100	(mm/s)/V	0 to 2,000	-
303	Analog Speed Command Movement Direction Switching		Set the polarity for analog speed commands.	1	-	0 to 1	-
		0	+Voltage: Forward direction -Voltage: Reverse direction				
		1	+Voltage: Reverse direction -Voltage: Forward direction				
304	No. 1 Internally Set Speed		Set the No. 1 internal speed command value.	0	mm/s	-20,000 to 20,000	-
305	No. 2 Internally Set Speed		Set the No. 2 internal speed command value.	0	mm/s		-
306	No. 3 Internally Set Speed		Set the No. 3 internal speed command value.	0	mm/s		-
307	No. 4 Internally Set Speed		Set the No. 4 internal speed command value.	0	mm/s		-
308	No. 5 Internally Set Speed		Set the No. 5 internal speed command value.	0	mm/s		-
309	No. 6 Internally Set Speed		Set the No. 6 internal speed command value.	0	mm/s		-
310	No. 7 Internally Set Speed		Set the No. 7 internal speed command value.	0	mm/s		-
311	No. 8 Internally Set Speed		Set the No. 8 internal speed command value.	0	mm/s		-
312	Soft Start Acceleration Time		Set the acceleration processing acceleration time for speed commands.	0	ms/ (1,000 mm/s)	0 to 10,000	-
313	Soft Start Deceleration Time		Set the deceleration processing acceleration time for speed commands.	0	ms/ (1,000 mm/s)	0 to 10,000	-

Pn number	Parameter name	Setting	Explanation	Default setting	Unit	Setting range	Power supply OFF to ON
314	S-curve Acceleration/Deceleration Time Setting		Set the acceleration/deceleration processing S-curve time for speed commands.	0	ms	0 to 1,000	–
315	Zero Speed Designation Selection		Select the function of the zero speed designation input (ZEROSPD).	0	–	0 to 3	–
		0	Disabled				
		1	The speed command is 0.				
		2	If the speed command is 0 and the actual speed is less than the zero speed designation, the servo is locked.				
	3	If the speed command is less than the zero speed designation level, the speed command becomes 0 and the servo is locked.					
316	Position Lock Level Setting		Set the threshold for position lock moving.	30	mm/s	10 to 20,000	–
317	Force Command/Speed Limit Selection		Select the force command and speed limit value.	0	–	0 to 2	–
		0	Force command: Analog input 1 Speed limit: Pn321 set value				
		1	Force command: Analog input 2 Speed limit: Analog input 1				
	2	Force command: Analog input 1 Speed limit: Pn321 and Pn322 set values					
318	Force Command Direction Selection		Select the method for selecting the direction for the force command.	0	–	0 to 1	–
		0	The direction depends on the polarity of the analogue force command				
	1	The direction depends on a digital input (FSIGN)					
319	Force Command Scale		Set the input gain for analog force command input.	30	0.1 V/100%	10 to 100	–
320	Analog Force Command Movement Direction Switching		Set the analog force command input polarity.	0	–	0 to 1	–
		0	Forward operation				
	1	Reverse operation					
321	Speed Limit Value Setting		Set the speed limit value.	0	mm/s	0 to 20,000	–
322	Reverse Direction Speed Limit Value Setting		Switch the speed limit value according to the direction.	0	mm/s	0 to 20,000	–
323	Encoder Type Selection		Select the encoder type.	0	–	0 to 2	Yes
		0	Phase AB output				
		1	SinCos Encoder via Serial Converter Unit or Incremental Serial communication type encoder.				
	2	Serial communications (Absolute encoder specifications)					

12-2 Parameter List

Pn number	Parameter name	Setting	Explanation	Default setting	Unit	Setting range	Power supply OFF to ON
326	Encoder Direction Switching		Reverse the encoder count direction by changing the setting.	0	-	0 to 1	Yes
		0	Count direction not reversed				
		1	Count direction reversed				
327	Encoder Phase-Z Setting		Enable/Disable the detection of misconnected Z pulse in A/B output encoder type.	0	-	0 to 1	Yes
		0	Enabled				
		1	Disabled				

Interface and Monitor Setting Parameters

Pn number	Parameter name	Setting	Explanation	Default setting	Unit	Setting range	Power supply OFF to ON
400	Input Signal Selection 1		Set the input signal 1 function and logic.	00828282h (8553090)	-	0 to 00FFFFFFh	Yes
401	Input Signal Selection 2		Set the input signal 2 function and logic.	00818181h (8487297)	-	0 to 00FFFFFFh	Yes
402	Input Signal Selection 3		Set the input signal 3 function and logic.	0091910Ah (9539850)	-	0 to 00FFFFFFh	Yes
403	Input Signal Selection 4		Set the input signal 4 function and logic.	0060606h (394758)	-	0 to 00FFFFFFh	Yes
404	Input Signal Selection 5		Set the input signal 5 function and logic.	0000100Ch (4108)	-	0 to 00FFFFFFh	Yes
405	Input Signal Selection 6		Set the input signal 6 function and logic.	00030303h (197379)	-	0 to 00FFFFFFh	Yes
406	Input Signal Selection 7		Set the input signal 7 function and logic.	00000F07h (3847)	-	0 to 00FFFFFFh	Yes
407	Input Signal Selection 8		Set the input signal 8 function and logic.	00040404h (263172)	-	0 to 00FFFFFFh	Yes
408	Input Signal Selection 9		Set the input signal 9 function and logic.	00050505h (328965)	-	0 to 00FFFFFFh	Yes
409	Input Signal Selection 10		Set the input signal 10 function and logic.	00000E88h (3720)	-	0 to 00FFFFFFh	Yes
410	Output Signal Selection 1		Set the output signal 1 function allocation.	00030303h (197379)	-	0 to 00FFFFFFh	Yes
411	Output Signal Selection 2		Set the output signal 2 function allocation.	00020202h (131586)	-	0 to 00FFFFFFh	Yes
412	Output Signal Selection 3		Set the output signal 3 function allocation.	00010101h (65793)	-	0 to 00FFFFFFh	Yes
413	Output Signal Selection 4		Set the output signal 4 function allocation.	00050505h (328964)	-	0 to 00FFFFFFh	Yes
414	Output Signal Selection 5		Set the output signal 5 function allocation.	00070707h (460551)	-	0 to 00FFFFFFh	Yes

Pn number	Parameter name	Setting	Explanation	Default setting	Unit	Setting range	Power supply OFF to ON
415	Output Signal Selection 6		Set the output signal 6 function allocation.	00060606h (394758)	—	0 to 00FFFFFFh	Yes
416	Analog Monitor 1 Selection		Select the type for analog monitor 1.	0	—	0 to 22	—
		0	Motor speed				
		1	Position command speed				
		2	Internal position command speed				
		3	Speed Control Command				
		4	Force command				
		5	Command position error				
		6	Encoder Position Error				
		7	Reserved				
		8	Reserved				
		9	P-N voltage				
		10	Regeneration load ratio				
		11	Overload load ratio				
		12	Forward direction force limit				
		13	Reverse direction force limit				
		14	Speed limit value				
		15	Mass Ratio				
		16	Analog input 1				
		17	Analog input 2				
		18	Analog input 3				
		19	Reserved				
		20	Drive temperature				
		21	Reserved				
22	Reserved						
417	Analog Monitor 1 Scale Setting		Set the output gain for analog monitor 1.	0	—	0 to 214,748,364	—
418	Analog Monitor 2 Selection		Select the type for analog monitor 2. The set values for this parameter are the same as Analog Monitor 1 Type (Pn416).	4	—	0 to 22	—
419	Analog Monitor 2 Scale Setting		Select the output gain for analog monitor 2.	0	—	0 to 214,748,364	—
420	Reserved		Do not change this setting.	—	—	—	—
421	Analog Monitor Output Setting		Select the analog monitor output voltage method.	0	—	0 to 2	—
		0	Output range: -10 to 10 V Data output: Positive, negative				
		1	Output range: 0 to 10 V Data output: Positive, negative				
		2	Output range: 0 to 10 V Data output: Positive, negative				

12-2 Parameter List

Pn number	Parameter name	Setting	Explanation	Default setting	Unit	Setting range	Power supply OFF to ON
422	Analog Input 1 Offset		Set the analog input 1 offset.	0	0.359 mV	-5,578 to 5,578	—
423	Analog Input 1 Filter Time Constant		Set the analog input 1 filter.	0	0.01 ms	0 to 6,400	—
424	Excessive Analog Input 1		Set the voltage after offset for the excess level of analog input 1 input voltage.	0	0.1 V	0 to 100	—
425	Analog Input 2 Offset		Set the analog input 2 offset.	0	5.86 mV	-342 to 342	—
426	Analog Input 2 Filter Time Constant		Set the analog input 2 filter.	0	0.01 ms	0 to 6,400	—
427	Excessive Analog Input 2		Set the voltage after offset for the excess level of analog input 2 input voltage.	0	0.1 V	0 to 100	—
428	Analog Input 3 Offset		Set the analog input 3 offset.	0	5.86 mV	-342 to 342	—
429	Analog Input 3 Filter Time Constant		Set the analog input 3 filter.	0	0.01 ms	0 to 6,400	—
430	Excessive Analog Input 3		Set the voltage after offset for the excess level of analog input 3 input voltage.	0	0.1 V	0 to 100	—
431	Positioning Completion Range 1		Set the allowed number of pulses for the positioning completion range.	10	Command unit	0 to 262,144	—
432	Positioning Completion Condition Selection		Set the judgment conditions for positioning completion output.	0	—	0 to 3	—
		0	Positioning completion output turns ON when the position error is within the Positioning Completion Range 1 (Pn431).				
		1	Positioning completion output turns ON when the position error is within in the Positioning Completion Range 1 (Pn431) and there is no position command.				
		2	Positioning completion output turns ON when the zero speed detection signal is ON, the position error is within the Positioning Completion Range 1 (Pn431) and there is no position command.				
		3	Positioning completion output turns ON when the position error is within in the Positioning Completion Range 1 (Pn431) and there is no position command. The ON status will then be held until the next position, command is received.				
433	Positioning Completion Hold Time		Set the positioning completion hold time.	0	1 ms	0 to 30,000	—

Pn number	Parameter name	Setting	Explanation	Default setting	Unit	Setting range	Power supply OFF to ON
434	Zero Speed Detection		Set the detection threshold for zero speed (ZSP).	50	mm/s	10 to 20,000	–
435	Speed Conformity Detection Range		Set the detection threshold for speed conformity output (V-COIN) with the difference between the speed command and the actual speed.	50	mm/s	10 to 20,000	–
436	Movement Speed for Motor Movement Detection		Set the detection threshold for speed reached output (AT-SPEED).	1000	mm/s	10 to 20,000	–
437	Brake Timing when Stopped		Set the operation time for the mechanical brake at stop.	0	1 ms	0 to 10,000	–
438	Brake Timing during Operation		Set the operation time for the mechanical brake during operation.	0	1 ms	0 to 10,000	–
439	Brake Release Speed Setting		Set the speed threshold for mechanical brake output judgment during operation.	30	mm/s	30 to 3,000	Yes
440	Warning Output Selection 1		Select the warning type for warning output 1.	0	–	0 to 10	–
		0	No				
		1	Overload warning				
		2	Excessive regeneration warning				
		3	Battery warning				
		4	Fan warning				
		5	Encoder communications warning				
		8	Encoder overheating warning				
		9	Encoder error warning				
10	Encoder communications error warning						
441	Warning Output Selection 2		Select the warning type for warning output 2. The relationships among the set values for this parameter are the same as for Warning Output Selection 1 (Pn440).	0	–	0 to 10	–
442	Positioning Completion Range 2		Set the allowable number of pulses for the second positioning completion range.	10	Command unit	0 to 262,144	–

Expansion Setting Parameters

Pn number	Parameter name	Setting	Explanation	Default setting	Unit	Setting range	Power supply OFF to ON
500	Electronic Ratio Numerator 2		Set the electronic ratio. If Pn500, Pn501, Pn502 = 0, the encoder resolution is set as the numerator. Electronic ratio numerator 2 (Pn500) or Electronic ratio numerator 3 (Pn501) or Electronic ratio numerator 4 (Pn502) Electronic ratio denominator (Pn010)	10000	–	1 to 1073741824	–
501	Electronic Ratio Numerator 3			10000	–	1 to 1073741824	–
502	Electronic Ratio Numerator 4			10000	–	1 to 1073741824	–
503	Encoder Dividing Denominator		Set the denominator when the number of pulses per motor movement in pulse regeneration is not an integer.	2500	–	0 to 262,144	Yes
504	Drive Prohibition Input Selection	0	Forward or reverse direction drive prohibition input enabled	1	–	0 to 2	Yes
		1	Forward or reverse direction drive prohibition input disabled				
		2	Forward or reverse direction drive prohibition input enabled				
505	Stop Selection for Drive Prohibition Input		Make the setting upon drive prohibition input.	0	–	0 to 2	Yes
		0	The force in the drive prohibit direction is disabled, and the dynamic brake is activated.				
		1	The force in the drive prohibit direction is disabled, and free-run deceleration is performed.				
		2	The force in the drive prohibit direction is disabled and an immediate stop is performed.				

Pn number	Parameter name	Setting	Explanation	Default setting	Unit	Setting range	Power supply OFF to ON
506	Stop Selection with Servo OFF		Set the stop operation when the servo is turned OFF.	0	-	0 to 9	-
		0	During deceleration: Dynamic brake After stopping: Dynamic brake Error counter: Clear				
		1	During deceleration: Free-run After stopping: Dynamic brake Error counter: Clear				
		2	During deceleration: Dynamic brake After stopping: Servo free Error counter: Clear				
		3	During deceleration: Free-run After stopping: Servo free Error counter: Clear				
		4	During deceleration: Dynamic brake After stopping: Dynamic brake Error counter: Hold				
		5	During deceleration: Free-run After stopping: Dynamic brake Error counter: Hold				
		6	During deceleration: Dynamic brake After stopping: Servo free Error counter: Hold				
		7	During deceleration: Free-run After stopping: Servo free Error counter: Hold				
		8	During deceleration: Immediate stop After stopping: Dynamic brake Error counter: Clear				
9	During deceleration: Immediate stop After stopping: Servo free Error counter: Clear						
507	Stop Selection with Main Power Supply OFF		Set the stop operation when the main power supply is turned OFF. The set values for this parameter are the same as Stop Selection with Servo OFF (Pn506).	0	-	0 to 9	-
508	Undervoltage Alarm Selection		Select whether to trip the LV or turn OFF the servo if there is a main power supply alarm.	1	-	0 to 1	-
509	Momentary Hold Time		Set the main power supply alarm detection time.	70	1 ms	70 to 2,000	Yes

12-2 Parameter List

Pn number	Parameter name	Setting	Explanation	Default setting	Unit	Setting range	Power supply OFF to ON
510	Stop Selection for Alarm Generation		Set the alarm sequence.	0	-	0 to 7	-
		0	During deceleration: Dynamic brake After stopping: Dynamic brake				
		1	During deceleration: Free-run After stopping: Dynamic brake				
		2	During deceleration: Dynamic brake After stopping: Servo free				
		3	During deceleration: Free-run After stopping: Servo free				
		4	During Immediate stop alarm deceleration: Immediate stop During deceleration: Dynamic brake After stopping: Dynamic brake				
		5	During Immediate stop alarm deceleration: Immediate stop During deceleration: Free-run After stopping: Dynamic brake				
		6	During Immediate stop alarm deceleration: Immediate stop During deceleration: Free-run After stopping: Servo free				
7	During Immediate stop alarm deceleration: Immediate stop During deceleration: Free-run After stopping: Servo free						
511	Immediate Stop Force		Set the force limit for immediate stops.	0	%	0 to 500	-
512	Overload Detection Level Setting		Set the overload detection level.	0	%	0 to 500	-
514	Overrun Limit Setting		Set the motor over-travel distance for position commands.	10	0.1 pole pitch	0 to 1,000	-
515	Control Input Signal Read Setting		Select from one of 4 values for the IF read cycle.	0	-	0 to 3	Yes
		0	0.166ms				
		1	0.333 ms				
		2	1 ms				
3	1.666 ms						
516	Alarm Reset Condition Setting		Set the alarm clear input detection method.	0	-	0 to 1	-
		0	120 ms				
		1	Follow the Control Input Signal Read Setting (Pn515).				

Pn number	Parameter name	Setting	Explanation	Default setting	Unit	Setting range	Power supply OFF to ON
517	Error Counter Reset Condition Selection		Set the counter clear input signal clear conditions.	3	-	0 to 4	-
		0	Disabled				
		1	Clears the error counter with the level. (Shorted for 500 μs or longer)				
		2	Clears the error counter with the level. (Shorted for 1 ms or longer)				
		3	Clears the error counter with the edge. (Change from open to shorted for 100μs or longer)				
4	Clears the error counter with the edge. (Change from open to shorted 1ms or longer)						
518	Command Pulse Prohibition Input Setting		Enable or disable the command pulse prohibition input signals (INH).	1	-	0 to 1	-
		0	Enabled				
1	Disabled						
519	Command Pulse Prohibition Input Read Setting		Select the signal reed cycle for the command pulse prohibit input.	0	-	0 to 4	-
		0	0.166ms				
		1	0.333 ms				
		2	1 ms				
		3	1.666 ms				
4	0.166 ms						
520	Position Setting Unit Selection		Select the positioning completion range and error counter overflow level setting unit.	0	-	0 to 1	Yes
		0	Command unit				
1	Encoder unit						
521	Force Limit Selection		Set the forward or reverse direction force limit selection method.	1	-	0 to 6	-
		0	Use P-ATL and N-ATL as analog force limit inputs.				
		1	Pn013 is the limit value for both forward and reverse directions.				
		2	Forward operation: Set by Pn013, Reverse operation: Set by Pn522.				
		3	When FL-SEL input is open: Use Pn013. When FL-SEL input is shorted: Use Pn522.				
		4	Use P-ATL and N-ATL as analog force limit inputs.				
		5	Use P-ATL and N-ATL as analog force limit inputs.				
6	When FL-SEL input is open: Forward direction, use Pn013; Reverse direction, use Pn522. When FL-SEL input is shorted: Forward direction, use Pn525; Reverse direction, use Pn526.						

12-2 Parameter List

Pn number	Parameter name	Setting	Explanation	Default setting	Unit	Setting range	Power supply OFF to ON
522	No. 2 Force Limit		Set the No. 2 limit value for the motor output force.	500	%	0 to 500	–
523	Force Limit Switching Setting 1		Set the change rate (fluctuate) for when the force limit is switched from No. 1 to No. 2.	0	ms/100%	0 to 4,000	–
524	Force Limit Switching Setting 2		Set the change rate (fluctuate) for when the force limit is switched from No. 2 to No. 1.	0	ms/100%	0 to 4,000	–
525	Forward External Force Limit		Set the forward direction force limit for FL-SEL input when Pn521 Force Limit Selection is set to 6.	500	%	0 to 500	–
526	Reverse External Force Limit		Set the reverse direction force limit for FL-SEL input when Pn521 Force Limit Selection is set to 6.	500	%	0 to 500	–
527	Analog Force Limit Scale		Set the gain of conversion for analog force limit input.	30	0.1 V/100%	10 to 100	–

Pn number	Parameter name	Setting	Explanation	Default setting	Unit	Setting range	Power supply OFF to ON
528	Default Display		Select the data to be displayed on the 7-segment LED initially when the control power supply is turned ON.	1		0 to 37	Yes
		0	Command position error		Command unit		
		1	Motor speed		mm/s		
		2	Position command speed		mm/s		
		3	Speed Control Command		mm/s		
		4	Force command		%		
		5	Total encoder pulses		Pulse		
		6	Total command pulses		Pulse		
		8	Total Encoder Feedback Pulses		Pulse		
		9	CONTROL mode		–		
		10	I/O signal status		–		
		11	Analog input value		V		
		12	Error factor, history		–		
		13	Warning number		–		
		14	Regeneration resistance load ratio		%		
		15	Overload load ratio		%		
		16	Mass Ratio		%		
		17	Reason for no movement		–		
		18	Display of the number of I/O signal changes		times		
		20	Reserved		–		
		21	Absolute encoder position		–		
		22	Monitor for the number of encoder communications errors		times		
		23	Display of axis numbers for communication		–		
		24	Position error (encoder unit)		–		
		25	Reserved		–		
		26	Reserved		–		
		27	P-N voltage		V		
		28	Soft version		–		
		29	Drive serial number		–		
		30	Reserved		–		
528	Default Display	31	Accumulative operation time		h	0 to 37	Yes
		32	Reserved		–		
		33	Drive temperature		°C		
		35	Safety status monitor		–		
		37	Linear motor status monitor		–		

12-2 Parameter List

Pn number	Parameter name	Setting	Explanation	Default setting	Unit	Setting range	Power supply OFF to ON
529	Reserved		Do not change this setting.	–	–	–	–
530	Reserved		Do not change this setting.	–	–	–	–
531	Axis Number		Set the axis number for communication.	1	–	0 to 127	Yes
532	Command Pulse Input Maximum Setting		Set the maximum command pulse input.	4000	kpps	250 to 4,000	Yes
533	Pulse Regeneration Limit Output Setting		Set the detection of pulse regeneration limit error.	0	–	0 to 1	Yes
		0	Disabled				
		1	Enabled				
534	Reserved		Do not change this setting.	–	–	–	–
535	Front Key Protection Setting		Set the operation limit for the front panel.	0	–	0 to 1	Yes
		0	Operation not blocked				
		1	Operation blocked				

Special Setting Parameters

Pn number	Parameter name	Setting	Explanation	Default setting	Unit	Setting range	Power supply OFF to ON
600	Analog Force Feed-forward Gain Setting		Set the input gain for analog force feed forward. 0 to 9 will be disabled.	0	0.1 V/ 100%	0 to 100	–
602	Maximum speed error		Set the maximum speed error before having error 24.1. Setting to 0 disables this alarm.	0	mm/s	0 to 20000	–
604	Jog Speed		Set the command speed during JOG trial operation (speed control).	50	mm/s	0 to 500	–
605	Gain 3 Effective Time		Set effective time of gain 3 of three-step gain switching.	0	0.1 ms	0 to 10,000	–
606	Gain 3 Ratio Setting		Set gain 3 as a multiple of gain 1.	100	%	100 to 1,000	–
607	Force Command Value Offset		Set offset force to add to force command.	0	%	-100 to 100	–
608	Forward Direction Force Offset		Set the value to add to a force command for forward direction operation.	0	%	-100 to 100	–
609	Reverse Direction Force Offset		Set the value to add to a force command for reverse direction operation.	0	%	-100 to 100	–
610	Function Expansion Setting		Set the function expansion. The setting contents vary depending on the function.	0	–	0 to 63	–
613	Mass Ratio 2		Set the mass ratio switching.	250	–	0 to 10,000	–
614	Alarm Generation Allowable Time Setting		Set the allowable time until stopping when an immediate stop is actuated upon alarm generation.	200	ms	0 to 1,000	–
615	Overspeed Detection Level Setting at Immediate Stop		During an immediate stop upon alarm generation, if the motor speed excess this set value, this is an overspeed 2 error.	0	mm/s	0 to 20,000	–
617	Front Panel Parameter Write Selection		Select the EEPROM write specifications when a parameter is changed.	0	–	0 to 1	Yes
		0	Writing not to be performed when a parameter is changed.				
		1	Writing to be performed when a parameter is changed.				
618	Power Supply ON Initialization Time		Set initialization time after power supply ON to the standard 1.5 s plus some.	0	0.1 s	0 to 100	Yes
620	Encoder Phase-Z Expansion Setting		Set the encoder phase-Z output width.	0	μs	0 to 400	Yes

12-2 Parameter List

Pn number	Parameter name	Setting	Explanation	Default setting	Unit	Setting range	Power supply OFF to ON
621	Serial Absolute Encoder Phase-Z Setting		Set the phase-Z regeneration position when the serial absolute encoder is used.	0	Pulse	0 to 268435456	Yes
622	Phase-AB Regeneration Method Selection for Encoder of Phase-AB Output Type	0	Without signal regeneration	0	-	0 to 1	Yes
		1	With signal regeneration				
623	Disturbance Force Compensation Gain		Set the compensation gain for disturbance force.	0	%	-100 to 100	-
624	Disturbance Observer Filter Setting		Set the filter time constant for disturbance force compensation.	53	0.01 ms	10 to 2,500	-
627	Warning Latch Hold Time Selection	0	Latch time infinite	5	-	0 to 10	Yes
		1-10	Latch time in seconds				
631	Realtime Autotuning Estimated Speed Selection		Set the load characteristics estimated speed when realtime autotuning is enabled.	1	-	0 to 3	Yes
		0	No changes are reflexed.				
		1	Changes are reflexed slowly (1 minute time constant)				
		2	Changes are reflexed gradually (few seconds time constant)				
	3	Changes are reflexed instantaneously (changes are applied as soon as they are detected)					
632	REALTIME AUTOTUNING CUSTOMIZATION mode Setting		Set the CUSTOMIZATION mode detail for realtime autotuning.	0	-	-32,768 to 32,767	-
637	Vibration Detection Threshold		Set the vibration detection threshold. If force vibration that exceeds this setting is detected, the vibration detection warning will occur.	0	0.1%	0 to 1,000	-
638	Warning Mask Setting		Set the warning detection mask setting. If you set the corresponding bit to 1, the corresponding warning detection will be disabled.	0	-	-32,768 to 32,768	Yes
639	Reserved		Do not change this setting.	-	-	-	-
640	Reserved		Do not change this setting.	-	-	-	-
641	Reserved		Do not change this setting.	-	-	-	-

Motor, Encoder and Magnetic pole estimation Setting Parameters

Pn number	Parameter name	Setting	Explanation	Default setting	Unit	Setting range	Power supply OFF to ON
900	Reserved		Do not change this setting.	–	–	–	–
901	Encoder resolution		Set the encoder resolution in $\mu\text{m}/\text{count}$ (after x4 multiplication in case of A/B Encoder).	0.000	$\mu\text{m}/\text{count}$	0.000 to 1048576	Yes
902	Pole pitch		Set the linear motor pole pitch value.	0.00	0.01mm	0.00 to 327.67	Yes
903	Reserved		Do not change this setting.	–	–	–	–
904	Motor coil weight		Set the linear motor coil weight.	0	0.01Kg	0 to 32767	Yes
905	Motor nominal force		Set the linear motor nominal force.	0.00	0.1N	0.0 to 327.67	Yes
906	Motor rated rms current		Set the linear motor rated rms current.	0.0	Arms	0.0 to 3276.7	Yes
907	Motor peak absolute current		Set the linear motor peak current as absolute peak, not rms.	0.0	A	0.0 to 3276.7	Yes
908	Motor inductance		Set the “per phase” motor inductance.	0.00	0.01mH	0.00 to 327.67	Yes
909	Motor resistance		Set the “per phase” motor resistance.	0.00	0.01 Ω	0.00 to 327.67	Yes
910	Overvelocity level		Set the velocity level to detect the error 26.0 (Overspeed protection).	0	mm/s	0 to 20000	Yes
911	Carrier frequency	Set values are:		0	–	0 to 1	Yes
		0	6KHz				
		1	12KHz				
912	Current response auto-adjustment		Automatically adjust the level of Pn913 (Proportional) and Pn914 (Integral) according to this value.	30	%	0 to 100	Yes
913	Current loop proportional gain		Set here the current loop proportional gain. If Pn912<>0 this value is set automatically.	50	–	0 to 32767	–
914	Current loop integral gain		Set here the current loop integral gain. If Pn912<>0 this value is set automatically.	10	–	0 to 32767	–
915	Current loop filter time constant		Set here the time constant for the force command filter. If this value is 0 the filter is disabled.	0.00	0.01ms	0.00 to 25.00	–
916	Reserved		Do not change this setting.	–	–	–	–
917	Reserved		Do not change this setting.	–	–	–	–
918	Reserved		Do not change this setting.	–	–	–	–
919	Reserved		Do not change this setting.	–	–	–	–

12-2 Parameter List

Pn number	Parameter name	Setting	Explanation	Default setting	Unit	Setting range	Power supply OFF to ON
920	Magnetic phase detection method	Select here the detection method:		0	-	0 to 3	Yes
		0	No detection.				
		1	Direct measurement via Hall sensor.				
		2	Magnetic phase detection.				
		3	Magnetic phase detection restoration.				
921	Magnetic phase value		When using Hall sensors, set here the angle between the motor and the motor phases.	0	Electric angle	0 to 360	Yes
922	Magnetic phase detection command Maximum time		Maximum time that the force command is applied when magnetic phase detection sequence is executed (Pn920=0).	200	ms	0 to 200	-
923	Magnetic phase detection Force command		Force command that is applied to the motor when magnetic phase detection sequence is executed (Pn920=2).	50	%	0 to 300	-
924	Magnetic phase detection maximum movement		The force command during magnetic detection sequence is set to 0 if the motor moves more than this amount while the force set in Pn923 is applied, regardless of the time set in Pn922.	100	Pulse(s)	0 to 32767	-
925	Magnetic phase detection movement for Stop judgement		During the Magnetic phase detection sequence, the motor is considered stopped when moves less than Pn925 pulses in 2ms and continues stopped for Pn926 ms.	40	Pulse(s)	0 to 32767	-
926	Magnetic phase detection time for Stop judgement		During the Magnetic phase detection sequence, the motor is considered stopped when moves less than Pn925 pulses in 2ms and continues stopped for Pn926ms.	40	ms	0 to 32767	-
927	Magnetic phase detection time limit		Set the maximum time for the motor to stop during the magnetic phase detection sequence before giving alarm 61.1 (magnetic phase estimation abnormality 2).	1000	ms	0 to 32767	-
928	Magnetic phase detection Force filter time		Set the time constant for the force filter used during the magnetic phase detection sequence. If the value is 0 the filter is disabled.	1.00	0.01ms	0.00 to 25.00	-
929	Motor overload curve selection		Selects between different overload curves according to the motor thermal time constant.	0	-	0 to 7	-

12-3 Safety Certification

ZERTIFIKAT ◆ CERTIFICATE ◆ 認証書 ◆ CERTIFICADO ◆ CERTIFICAT

A1 / 03.08



CERTIFICATE

No. Z10 09 07 59301 130

Holder of Certificate: OMRON Corporation

2-2-1, Nishi-Kusatsu
Kusatsu-city
Shiga-ken
525-0035 JAPAN

Certification Mark:



Product:

**AC Servo Systems
AC Servo Amplifier**

The product was tested on a voluntary basis and complies with the essential requirements. The certification mark shown above can be affixed on the product. It is not permitted to alter the certification mark in any way. In addition the certification holder must not transfer the certificate to third parties. See also notes overleaf.

Test report no.:

PO82586T

Date, 2009-07-23

Page 1 of 3



TÜV SÜD Product Service GmbH · Zertifizierstelle · Ridlerstrasse 65 · 80339 München · Germany

TÜV®

12

Appendix

ZERTIFIKAT ◆ CERTIFICATE ◆ 認証書 ◆ CERTIFICADO ◆ CERTIFICAT



CERTIFICATE
No. Z10 09 07 59301 130

Model(s): **OMNUC G5 Series**
For nomenclature see attachment

Parameters:

Rated voltage:	100-120 VAC 200-240 VAC 380-480 VAC
Rated input current:	Max. 21.6 A
Operating temperature:	0°C ... +55°C

Tested according to:

- 2006/42/EC Machinery Directive (valid from 29 Dec. 2009)
- IEC 61508:1998 (Part 1, 3 and 4) SIL 2
- IEC 61508:2000 (Part 2) SIL 2
- EN 61508:2001 (Part 1 to 4) SIL 2
- EN 954-1:1996 Cat. 3
- IEC 61800-5-2:2007 / EN 61800-5-2:2007
- ISO 13849-1:2006 PL c, PL d
- EN ISO 13849-1:2008 PL c, PL d
- IEC 62061:2005 / EN 62061:2005 SIL 2
- IEC 61800-5-1:2007 / EN 61800-5-1:2007
- IEC 61800-3:2004 / EN 61800-3:2004
- IEC 61000-6-2:2005 / EN 61000-6-2:2005
- IEC 61326-3-1:2008
- EN 55011/A2:2007

Factory(ies): 54068

Main-Certificate no.: Z10 09 06 22944 150

Page 2 of 3

A1 / 03.08

TÜV SÜD Product Service GmbH · Zertifizierstelle · Ridlerstrasse 65 · 80339 München · Germany

TUV®



Attachment to certificate Z10 09 07 59301 130

Nomenclature of product type

R88D - K I 01 H A - ZR1
 I II III IV V VI VII

I. Manufacturer's Designation:
 R88D – Normal

II. Manufacturer's Designation:
 K – Normal

III. Input Signal Specification:
 T – Analog / pulse input type

IV. Output rating:
 A5 – 50W
 01 – 100W
 02 – 200W
 04 – 400W
 08 – 750W
 10 – 1kW
 15 – 1.5kW
 20 – 2kW
 30 – 3kW
 50 – 5kW

V. Input Voltage Specification:
 L – AC100V
 H – AC200V
 F – AC400V

VI. Design Revision (Non-critical) (max 1 character): * See Remark
 blank or any number

VII. Internal Specification (Non-critical) (max 3 characters): * See Remark
 blank or any alphanumeric suffix
 (if VII is not blank, a hyphen is inserted between VI and VII.
 Otherwise, no hyphen is inserted.)

*) Remark

Details of the combination of VI and VII are shown below.

VI	VII	Specification
Blank	Blank	Functional Safety Model
Any number	Blank or Alphanumeric	Functional Safety Model
No other 2 digits combination will be placed in the market		

Department: TR-RAMUC
Date: 2009-07-23

Page 3 of 3

TÜV SÜD Product Service GmbH · Zertifizierstelle · Ridlerstrasse 65 · 80339 München · Germany



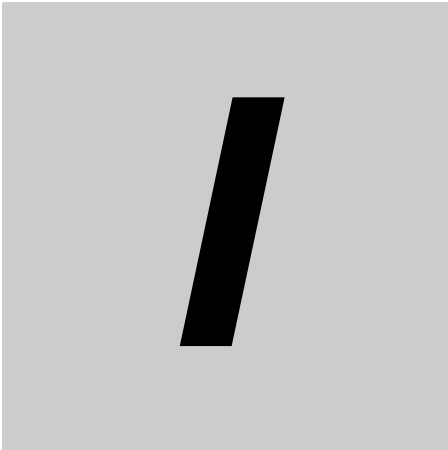

Index



Index

Numerics

- 2,000-r/min motors 2-8
- 3,000-r/min motors 2-8

A

- Absolute encoder setup 9-5, 9-8
- Adaptive filter 6-7
- Adaptive Filter Selection (Pn200) 8-20
- Alarm clear 9-28
- Alarm clear attribute output (ALM-ATB) 3-44
- Alarm Generation Allowable Time Setting (Pn614) 8-58
- Alarm list 11-7
- Alarm output (/ALM) 3-42
- Alarm Reset Condition Selection (Pn516) 8-51
- Alarm reset input (RESET) 3-32
- Allowable current 4-28
- Analog Input 1 Filter Time Constant (Pn423) 8-39
- Analog Input 1 Offset (Pn422) 8-38
- Analog Input 2 Filter Time Constant (Pn426) 8-39
- Analog Input 2 Offset (Pn425) 8-39
- Analog Input 3 Filter Time Constant (Pn429) 8-40
- Analog Input 3 Offset (Pn428) 8-40
- Analog input automatic offset adjustment 9-29
- Analog Monitor 1 Scale Setting (Pn417) 8-37
- Analog Monitor 2 Scale Setting (Pn419) 8-37
- Analog Monitor 2 Selection (Pn418) 8-37
- Analog monitor cable 2-12
- Analog Monitor Output Selection (Pn421) 8-38
- Analog Speed Command Rotation Direction Switching (Pn303) 8-26
- Analog Torque Command Rotation Direction Switching (Pn320) 8-32
- Analog Torque Limit Scale (Pn527) 8-54
- Applicable standards 1-11
- Axis Number (Pn531) 8-55, 8-56

B

- Brake interlock 6-18
- Brake interlock output (BKIR) 3-42
- Brake Release Speed Setting (Pn439) 8-44
- Brake Timing during Operation (Pn438) 8-43
- Brake Timing when Stopped (Pn437) 8-43

C

- Changing the mode 9-11
- Clamp core 4-38
- Command Pulse Input Maximum Setting (Pn532) 8-56
- Command Pulse Input Selection (Pn005) 8-4
- COMMAND PULSE mode Selection (Pn007) 8-4
- Command Pulse Prohibition Input Read Setting (Pn519) 8-52
- Command Pulse Prohibition Input Setting (Pn518) 8-51
- Command Pulse Rotation Direction Switching Selection (Pn006) 8-4
- Command Speed Selection (Pn300) 8-25
- Communications connector specifications (CN3A) 3-53
- Connection examples 12-2
- Connectors 2-13
- Connector-terminal block 2-15

- Connector-terminal block cables 2-15, 3-107
- Connector-terminal Block Conversion Unit 3-109
- Contact 4-40
- Control cable specifications 3-76, 3-79, 3-82
- Control cables 2-15
- Control circuit connector specifications (CND) 4-24
- Control I/O connector 3-94
- Control I/O connector specifications 3-13
- Control input circuits 3-23
- Control input signal 3-16
- Control Input Signal Read Setting (Pn515) 8-50
- CONTROL mode Selection (Pn001) 8-2
- CONTROL mode switching (TVSEL) 3-33
- Control output circuits 3-39
- Control output sequence 3-40

D

- Damping control 6-3
- Default Display (Pn528) 8-54
- Disturbance Observer Filter Setting (Pn624) 8-60
- Disturbance Torque Compensation Gain (Pn623) 8-60
- Drive Prohibition Input Selection (Pn504) 8-45
- Driver characteristics 3-4
- Driver general specifications 3-3
- Driver part functions 1-5
- Driver part names 1-4

E

- EC directive 1-11
- Electronic gear function 6-12
- Electronic Gear Ratio Denominator (Pn010) 8-6
- Electronic Gear Ratio Numerator 1 (Pn009) 8-6
- Electronic Gear Ratio Numerator 2 (Pn500) 8-45
- Electronic Gear Ratio Numerator 3 (Pn501) 8-45
- Electronic Gear Ratio Numerator 4 (Pn502) 8-45
- Electronic gear switching 1 (GESEL1) 3-34
- Electronic gear switching 2 (GESEL2) 3-34
- Emergency stop input (EMG-STP) 3-37
- Encoder cable 3-76, 3-79, 3-82
- Encoder cables (robot cables) 3-76, 3-78, 3-79, 3-80, 3-81, 3-82, 3-83, 3-84, 3-86, 3-87
- Encoder Cables (Standard Cables) 2-11, 2-12
- Encoder connectors 3-94
- Encoder Dividing Denominator (Pn503) 8-45
- Encoder Dividing Numerator (Pn011) 8-7
- Encoder Output Direction Switching Selection (Pn012) 8-7
- Encoder outputs (Phases A, B and Z) 3-41
- Error Counter Overflow Level (Pn014) 8-7
- Error Counter Reset Condition Selection (Pn517) 8-51
- Error counter reset input (ECRST) 3-33
- Error diagnosis using the alarm displays 11-11
- Error diagnosis using the operation status 11-18
- Error processing 11-2
- Excessive Analog Input 1 (Pn424) 8-39
- Excessive Analog Input 2 (Pn427) 8-39
- Excessive Analog Input 3 (Pn430) 8-40
- External dimensions 2-17
- External Feedback Pulse Direction Switching (Pn326) 8-34
- External Feedback Pulse Phase-Z Setting (Pn327) 8-34

External Regeneration Resistor 2-15
 External Regeneration Resistor connector specifications (CNC) 4-23, 4-24
 External Regeneration Resistor Setting (Pn017) 8-8
 External Regeneration Resistor specifications 3-130
 External scale connector specifications (CN4) 3-46

F

Forward Direction Torque Offset (Pn608) 8-57
 Forward drive prohibition input (POT) 3-32
 Forward External Torque Limit (Pn525) 8-54
 Forward torque limit input (PCL) 3-31
 Front Panel Parameter Write Selection (Pn617) 8-59
 FULL CLOSING CONTROL mode adjustment 10-13
 Function Expansion Setting (Pn610) 8-57

G

Gain 3 Effective Time (Pn605) 8-57
 Gain 3 Ratio Setting (Pn606) 8-57
 Gain adjustment 10-2
 Gain switching (GSEL) 3-33
 Gain Switching Delay Time in Position Control (Pn116) 8-15
 Gain Switching Delay Time in Speed Control (Pn121) 8-17
 Gain Switching Delay Time in Torque Control (Pn125) 8-19
 Gain switching function 6-23
 Gain Switching Hysteresis in Position Control (Pn118) 8-15
 Gain Switching Hysteresis in Speed Control (Pn123) 8-17
 Gain Switching Hysteresis in Torque Control (Pn127) 8-19
 GAIN SWITCHING INPUT OPERATING mode Selection (Pn114) 8-12
 Gain Switching Level in Position Control (Pn117) 8-15
 Gain Switching Level in Speed Control (Pn122) 8-17
 Gain Switching Level in Torque Control (Pn126) 8-19
 General control cable 2-15, 3-105
 General-purpose input 3-26

H

Harmonic current measures 4-43

I

Immediate Stop Torque (Pn511) 8-49
 Improving Control I/O Signal Noise Resistance 4-42
 Improving encoder cable noise resistance 4-41
 Inertia Ratio (Pn004) 8-3
 Inertia Ratio 2 (Pn613) 8-58
 Inertia ratio switching input (JSEL) 3-38
 Input Signal Selection 1 (Pn400) 8-35
 Input Signal Selection 10 (Pn409) 8-35
 Input Signal Selection 2 (Pn401) 8-35
 Input Signal Selection 3 (Pn402) 8-35
 Input Signal Selection 4 (Pn403) 8-35
 Input Signal Selection 5 (Pn404) 8-35
 Input Signal Selection 6 (Pn405) 8-35

Input Signal Selection 7 (Pn406) 8-35
 Input Signal Selection 8 (Pn407) 8-35
 Input Signal Selection 9 (Pn408) 8-35
 Internally set speed control 5-19
 Internally set speed selection 1, 2 and 3 (VSEL1, 2 and 3) 3-35

J

Jog operation 9-30
 Jog Speed (Pn604) 8-57

L

Leakage Breaker 4-36

M

Main circuit connector specifications (CNA) 3-9, 3-10, 3-11, 4-22, 4-23, 4-24
 Main circuit terminal block specifications 3-12
 Maintenance 11-23
 Manual tuning 10-12
 Momentary Hold Time (Pn509) 8-48
 Monitor connector specifications (CN5) 3-51
 MONITOR mode 9-12
 Motion Control Unit Cable 3-96
 Motor characteristics 3-57, 3-66
 Motor connector specifications (CNB) 3-9, 3-10, 3-11, 4-22, 4-23, 4-24
 Motor connector specifications (CNC) 3-10, 3-11
 Motor connector specifications (CND) 3-11
 Motor general specifications 3-56, 3-60, 3-64, 3-65, 3-69, 3-74
 Motor power cable 3-91
 Motor power cables (standard cables) 2-11, 2-12
 Mounting brackets (L-brackets for rack mounting) 2-16
 Mounting dimensions 2-17

N

No. 1 Internally Set Speed (Pn304) 8-26
 No. 1 Torque Limit (Pn013) 8-7
 No. 2 Internally Set Speed (Pn305) 8-27
 No. 2 Torque Limit (Pn522) 8-53
 No. 3 Internally Set Speed (Pn306) 8-27
 No. 4 Internally Set Speed (Pn307) 8-27
 No. 5 Internally Set Speed (Pn308) 8-27
 No. 6 Internally Set Speed (Pn309) 8-27
 No. 7 Internally Set Speed (Pn310) 8-27
 No. 8 Internally Set Speed (Pn311) 8-27
 No-fuse breaker (NFB) 4-35
 Noise filter 4-38
 Noise filters for brake power supply 4-38
 Notch 1 Depth Setting (Pn203) 8-20
 Notch 1 Frequency Setting (Pn201) 8-20
 Notch 1 Width Setting (Pn202) 8-20
 Notch 2 Depth Setting (Pn206) 8-21
 Notch 2 Frequency Setting (Pn204) 8-20
 Notch 2 Width Setting (Pn205) 8-20
 Notch 3 Depth Setting (Pn209) 8-21
 Notch 3 Frequency Setting (Pn207) 8-21
 Notch 3 Width Setting (Pn208) 8-21

Index

- Notch 4 Depth Setting (Pn212) 8-21
- Notch 4 Frequency Setting (Pn210) 8-21
- Notch 4 Width Setting (Pn211) 8-21

O

- Operation command (RUN) 3-32
- Operational procedure 9-2
- Output during speed limit (V-LIMIT) 3-44
- Output Signal Selection 1 (Pn410) 8-35
- Output Signal Selection 2 (Pn411) 8-35
- Output Signal Selection 3 (Pn412) 8-35
- Output Signal Selection 4 (Pn413) 8-35, 8-36
- Overload Detection Level Setting (Pn512) 8-50
- Overrun Limit Setting (Pn514) 8-50
- Overspeed Detection Level Setting at Immediate Stop (Pn615) 8-59

P

- Parameter list 12-12
- PARAMETER SETTING mode 9-25
- PARAMETER WRITE mode 9-27
- Periodic maintenance 11-23
- Phase-Z output (open collector output) 3-39
- Pin arrangement 3-22
- Position Command Filter Time Constant (Pn222) 8-23
- Position command pulse 3-23, 3-24
- Position command status output (P-CMD) 3-44
- Position control 5-2
- POSITION CONTROL mode adjustment 10-13
- Position Control Unit-Servo Relay Unit cable specifications 3-121
- Position feedback output 3-39
- Position Gain Switching Time (Pn119) 8-15
- Position Lock Level Setting (Pn316) 8-30
- Position Loop Gain (Pn100) 8-9
- Position Loop Gain 2 (Pn105) 8-11
- Position Setting Unit Selection (Pn520) 8-52
- Positioning Completion Condition Selection (Pn432) 8-41
- Positioning Completion Hold Time (Pn433) 8-41
- Positioning completion output 1 (INP1) 3-42
- Positioning completion output 2 (INP2) 3-42
- Positioning Completion Range 1 (Pn431) 8-40
- Positioning Completion Range 2 (Pn442) 8-44
- Power cables without brakes (robot cables) 3-91, 3-93
- Power Supply ON Initialization Time (Pn618) 8-59
- Preparing for operation 9-3
- Protective functions 3-8
- Pulse prohibition input (IPG) 3-35
- Pulse Regeneration Output Limit Setting (Pn533) 8-56

R

- Radio noise filter 4-38
- Reactor 3-132, 4-43
- Reactor to reduce harmonic current 4-43
- Realtime autotuning 10-4
- REALTIME AUTOTUNING CUSTOMIZATION mode Setting (Pn632) 8-61

- Realtime Autotuning Estimated Speed Selection (Pn631) 8-61
- Realtime Autotuning Machine Rigidity Setting (Pn003) 8-3
- REALTIME AUTOTUNING mode Selection (Pn002) 8-3
- Regeneration absorption capacity 4-46
- Regeneration Resistor Selection (Pn016) 8-8
- Regenerative energy absorption 4-44
- Regenerative energy with an External Regeneration Resistor 4-47
- Replacement method 11-4
- Replacing the Servo Drive 11-4
- Replacing the Servomotor 11-4
- Reverse Direction Speed Limit Value Setting (Pn322) 8-32
- Reverse Direction Torque Offset (Pn609) 8-57
- Reverse drive prohibition input (NOT) 3-32
- Reverse External Torque Limit (Pn526) 8-54
- Reverse torque limit input (NCL) 3-31
- Rotation Speed for Motor Rotation Detection (Pn436) 8-42

S

- Safety connector specifications (CN8) 3-53
- S-curve Acceleration/Deceleration Time Setting (Pn314) 8-28
- Sequence output 3-39
- Servo Drive and Servomotor combination list 2-9
- Servo Drive dimensions 2-17
- Servo Drive installation conditions 4-2
- Servo Drive limit 11-24
- Servo Drive models 2-7
- Servo ready completed output (READY) 3-42
- Servo Relay Unit 2-13, 3-112
- Servo Relay Unit cables for Servo Drives 2-14
- Servo Relay Unit cables for Position Control Units 2-14
- Servomotor installation conditions 4-4
- Servomotor limit 11-23
- Servomotor models 2-8
- Setting the mode 9-11
- Smoothing Filter Time Constant (Pn223) 8-24
- Soft Start Acceleration Time (Pn312) 8-27
- Soft Start Deceleration Time (Pn313) 8-28
- Speed Command Direction Selection (Pn301) 8-25
- Speed command input (REF) 3-23, 3-30
- Speed Command Scale (Pn302) 8-26
- Speed command sign input (VSIGN) 3-36
- Speed command status output (V-CMD) 3-45
- Speed Conformity Detection Width (Pn435) 8-42
- Speed conformity output (TGON) 3-43
- Speed conformity output signal (VCMP) 3-43
- Speed control 5-8
- SPEED CONTROL mode adjustment 10-14
- Speed Feedback Filter Time Constant (Pn103) 8-11
- Speed Feedback Filter Time Constant 2 (Pn108) 8-11
- Speed Feed-forward Command Filter (Pn111) 8-12
- Speed Feed-forward Gain (Pn110) 8-12
- Speed limit input (VLIM) 3-23
- Speed limit value 10-19
- Speed Limit Value Setting (Pn321) 8-32
- Speed Loop Gain (Pn101) 8-10

Speed Loop Gain 2 (Pn106)	8-11
Speed Loop Integral Time Constant (Pn102)	8-10
Speed Loop Integral Time Constant 2 (Pn107)	8-11
Stop Selection for Alarm Generation (Pn510)	8-48
Stop Selection for Drive Prohibition Input (Pn505)	8-46
Stop Selection with Main Power Supply OFF (Pn507)	8-47
Stop Selection with Servo OFF (Pn506)	8-46
Surge absorber	4-37
Surge suppressor	4-40
Switching control	5-22
SWITCHING mode in Position Control (Pn115)	8-13
SWITCHING mode in Speed Control (Pn120)	8-16
SWITCHING mode in Torque Control (Pn124)	8-18
System block diagrams	1-6
System configuration	1-3

T

Terminal block specifications	4-25
Terminal Block Wire Sizes	4-25
Terminal block wiring	4-29
Torque Command Direction Selection (Pn318)	8-30
Torque Command Filter Time Constant (Pn104)	8-11
Torque command input 1 (TREF1)	3-23
Torque command input 2 (TREF2)	3-31
Torque Command Scale (Pn319)	8-32
Torque command sign input (TSIGN)	3-37
Torque Command Value Offset (Pn607)	8-57
Torque Command/Speed Limit Selection (Pn317)	8-30
Torque control	5-14
TORQUE CONTROL mode adjustment	10-19
Torque Feed-forward Amount (Pn112)	8-12
Torque Feed-forward Command Filter (Pn113)	8-12
Torque limit	6-31, 6-32
Torque Limit Selection (Pn521)	8-53
Torque limit switching (TLSEL)	3-37
Torque Limit Switching Setting 1 (Pn523)	8-54
Torque Limit Switching Setting 2 (Pn524)	8-54
Torque limiting signal (TLIMIT)	3-43
Trial operation	9-35
Troubleshooting	11-11

U

UL and cUL standards	1-11
Undervoltage Alarm Selection (Pn508)	8-48
USB connector specifications (CN7)	3-52

V

Vibration detection threshold	8-61
Vibration Filter 1 Setting (Pn215)	8-22
Vibration Filter 2 Setting (Pn217)	8-22
Vibration Filter 3 Setting (Pn219)	8-23
Vibration Filter 4 Setting (Pn221)	8-23
Vibration Filter Selection (Pn213)	8-21
Vibration filter switching 1 (DFSEL1)	3-34
Vibration filter switching 2 (DFSEL2)	3-34
Vibration Frequency 1 (Pn214)	8-22
Vibration Frequency 2 (Pn216)	8-22
Vibration Frequency 3 (Pn218)	8-23
Vibration Frequency 4 (Pn220)	8-23

W

Warning Latch Hold Time Selection (Pn627)	8-60
Warning mask setting	8-61
Warning output 1 (WARN1)	3-44
Warning output 2 (WARN2)	3-44
Warning Output Selection 1 (Pn440)	8-44
Warning Output Selection 2 (Pn441)	8-44
Wire sizes	4-28
Wiring conforming to EMC directives	4-30

Z

Zero speed designation (VZERO)	3-36
Zero Speed Designation Selection (Pn315)	8-28
Zero Speed Detection (Pn434)	8-41
Zero speed detection signal (ZSP)	3-43

OMRON AUTOMATION AND SAFETY • THE AMERICAS HEADQUARTERS • Chicago, IL USA • 847.843.7900 • 800.556.6766 • www.omron247.com

OMRON CANADA, INC. • HEAD OFFICE

Toronto, ON, Canada • 416.286.6465 • 866.986.6766 • www.omron247.com

OMRON ELECTRONICS DE MEXICO • HEAD OFFICE

México DF • 52.55.59.01.43.00 • 01-800-226-6766 • mela@omron.com

OMRON ELECTRONICS DE MEXICO • SALES OFFICE

Apodaca, N.L. • 52.81.11.56.99.20 • 01-800-226-6766 • mela@omron.com

OMRON ELETRÔNICA DO BRASIL LTDA • HEAD OFFICE

São Paulo, SP, Brasil • 55.11.2101.6300 • www.omron.com.br

OMRON ARGENTINA • SALES OFFICE

Cono Sur • 54.11.4783.5300

OMRON CHILE • SALES OFFICE

Santiago • 56.9.9917.3920

OTHER OMRON LATIN AMERICA SALES

54.11.4783.5300

OMRON EUROPE B.V. • Wegalaan 67-69, NL-2132 JD, Hoofddorp, The Netherlands. • +31 (0) 23 568 13 00 • www.industrial.omron.eu

Authorized Distributor:

Automation Control Systems

- Machine Automation Controllers (MAC) • Programmable Controllers (PLC)
- Operator interfaces (HMI) • Distributed I/O • Software

Drives & Motion Controls

- Servo & AC Drives • Motion Controllers & Encoders

Temperature & Process Controllers

- Single and Multi-loop Controllers

Sensors & Vision

- Proximity Sensors • Photoelectric Sensors • Fiber-Optic Sensors
- Amplified Photomicrosensors • Measurement Sensors
- Ultrasonic Sensors • Vision Sensors

Industrial Components

- RFID/Code Readers • Relays • Pushbuttons & Indicators
- Limit and Basic Switches • Timers • Counters • Metering Devices
- Power Supplies

Safety

- Laser Scanners • Safety Mats • Edges and Bumpers • Programmable Safety Controllers • Light Curtains • Safety Relays • Safety Interlock Switches

Компания «Океан Электроники» предлагает заключение долгосрочных отношений при поставках импортных электронных компонентов на взаимовыгодных условиях!

Наши преимущества:

- Поставка оригинальных импортных электронных компонентов напрямую с производств Америки, Европы и Азии, а так же с крупнейших складов мира;
- Широкая линейка поставок активных и пассивных импортных электронных компонентов (более 30 млн. наименований);
- Поставка сложных, дефицитных, либо снятых с производства позиций;
- Оперативные сроки поставки под заказ (от 5 рабочих дней);
- Экспресс доставка в любую точку России;
- Помощь Конструкторского Отдела и консультации квалифицированных инженеров;
- Техническая поддержка проекта, помощь в подборе аналогов, поставка прототипов;
- Поставка электронных компонентов под контролем ВП;
- Система менеджмента качества сертифицирована по Международному стандарту ISO 9001;
- При необходимости вся продукция военного и аэрокосмического назначения проходит испытания и сертификацию в лаборатории (по согласованию с заказчиком);
- Поставка специализированных компонентов военного и аэрокосмического уровня качества (Xilinx, Altera, Analog Devices, Intersil, Interpoint, Microsemi, Actel, Aeroflex, Peregrine, VPT, Syfer, Eurofarad, Texas Instruments, MS Kennedy, Miteq, Cobham, E2V, MA-COM, Hittite, Mini-Circuits, General Dynamics и др.);

Компания «Океан Электроники» является официальным дистрибьютором и эксклюзивным представителем в России одного из крупнейших производителей разъемов военного и аэрокосмического назначения «JONHON», а так же официальным дистрибьютором и эксклюзивным представителем в России производителя высокотехнологичных и надежных решений для передачи СВЧ сигналов «FORSTAR».



JONHON

«JONHON» (основан в 1970 г.)

Разъемы специального, военного и аэрокосмического назначения:

(Применяются в военной, авиационной, аэрокосмической, морской, железнодорожной, горно- и нефтедобывающей отраслях промышленности)

«FORSTAR» (основан в 1998 г.)

ВЧ соединители, коаксиальные кабели, кабельные сборки и микроволновые компоненты:

(Применяются в телекоммуникациях гражданского и специального назначения, в средствах связи, РЛС, а так же военной, авиационной и аэрокосмической отраслях промышленности).



Телефон: 8 (812) 309-75-97 (многоканальный)

Факс: 8 (812) 320-03-32

Электронная почта: ocean@oceanchips.ru

Web: <http://oceanchips.ru/>

Адрес: 198099, г. Санкт-Петербург, ул. Калинина, д. 2, корп. 4, лит. А