

This IC incorporates a general purpose analog circuit in a small package. This is a zero-drift operational amplifier with Rail-to-Rail input and output, which uses chopper-stabilizing techniques to provide low input offset voltage.

The S-89630AB is a dual operational amplifier (2 circuits), which is suitable for applications requiring less offset voltage.

■ Features

- Low input offset voltage: $V_{IO} = +50 \mu\text{V max. (Ta = -40}^\circ\text{C to +125}^\circ\text{C)}$
- Low input offset voltage drift: $\frac{\Delta V_{IO}}{\Delta Ta} = \pm 25 \text{ nV}/^\circ\text{C typ. (V}_{DD} = 30.0 \text{ V, Ta = -40}^\circ\text{C to +125}^\circ\text{C)}$
- Operation power supply voltage range: $V_{DD} = 4.0 \text{ V to } 36.0 \text{ V (Single supply)}$
 $V_{DD} = \pm 2.0 \text{ V to } \pm 18.0 \text{ V (Dual supply)}$
- Low current consumption (Per circuit): $I_{DD} = 250 \mu\text{A typ.}$
- Low input noise voltage: $V_{NOISE_pp} = 0.8 \mu\text{Vpp typ. (f = 0.1 Hz to 10 Hz)}$
- Low input noise voltage density: $V_{NOISE} = 25 \text{ nV}/\sqrt{\text{Hz typ. (f = 1 kHz)}$
- Built-in output current limit circuit: Overcurrent limit when output pin is short-circuited
- Internal phase compensation: No external parts required
- Rail-to-Rail input and output
- Operation temperature range: $Ta = -40}^\circ\text{C to +125}^\circ\text{C}$
- Lead-free (Sn 100%), halogen-free

■ Applications

- High-accuracy current detection
- Various sensor interfaces
- Strain gauge amplifier

■ Package

- TMSOP-8

■ Block Diagram

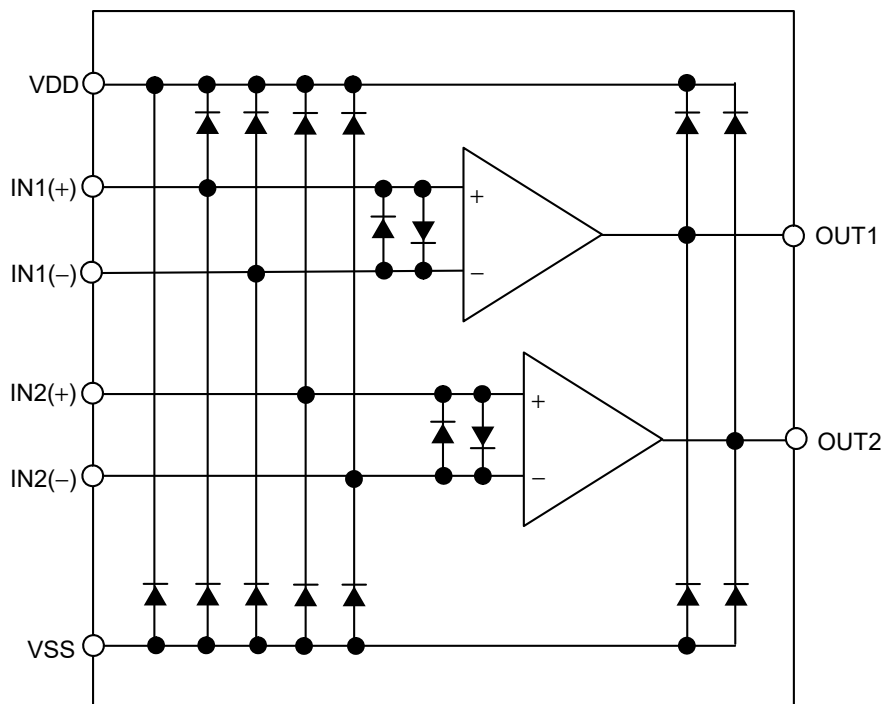
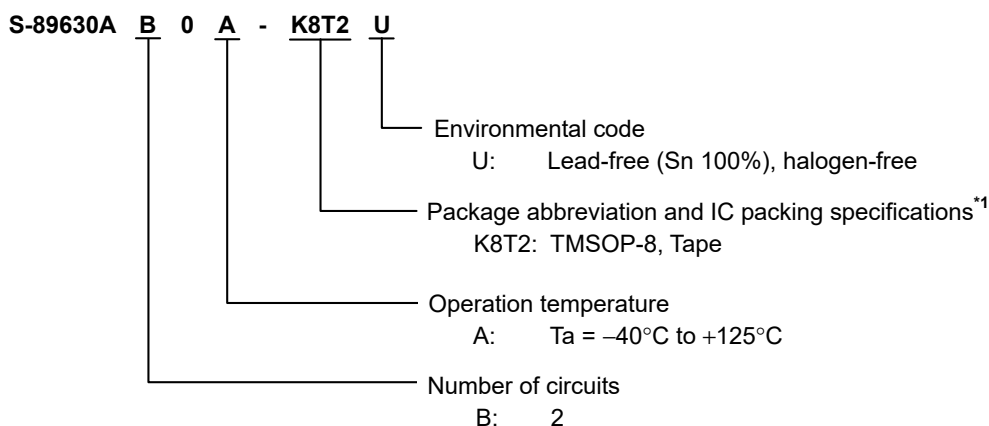

Figure 1

■ Product Name Structure

Refer to "1. Product name" regarding the contents of product name, "2. Package" regarding the package drawings and "3. Product name list" regarding the product type.

1. Product name



*1. Refer to the tape drawing.

2. Package

Table 1 Package Drawing Codes

Package Name	Dimension	Tape	Reel
TMSOP-8	FM008-A-P-SD	FM008-A-C-SD	FM008-A-R-SD

3. Product name list

Table 2

Product Name	Package
S-89630AB0A-K8T2U	TMSOP-8

■ Pin Configuration

1. TMSOP-8

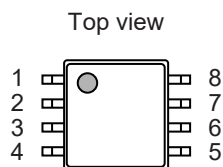

Figure 2

Table 3

Pin No.	Symbol	Description
1	OUT1	Output pin 1
2	IN1(-)	Inverted input pin 1
3	IN1(+)	Non-inverted input pin 1
4	VSS	GND pin
5	IN2(+)	Non-inverted input pin 2
6	IN2(-)	Inverted input pin 2
7	OUT2	Output pin 2
8	VDD	Positive power supply pin

■ Absolute Maximum Ratings

Table 4

(T_j = -40°C to +150°C unless otherwise specified)

Item	Symbol	Absolute Maximum Rating	Unit
Power supply voltage	V _{DD}	V _{SS} - 0.3 to V _{SS} + 45.0	V
Input voltage	V _{IN(+)} , V _{IN(-)}	V _{SS} - 0.3 to V _{DD} + 0.3	V
Output voltage	V _{OUT}	V _{SS} - 0.3 to V _{DD} + 0.3	V
Differential input voltage	V _{IND}	±0.5	V
Input pin current	I _{IN}	±10.0	mA
Junction temperature	T _j	-40 to +150	°C
Operation ambient temperature	T _{opr}	-40 to +125	°C
Storage temperature	T _{stg}	-40 to +150	°C

Caution The absolute maximum ratings are rated values exceeding which the product could suffer physical damage. These values must therefore not be exceeded under any conditions.

■ Thermal Resistance Value

Table 5

Item	Symbol	Condition	Min.	Typ.	Max.	Unit	
Junction-to-ambient thermal resistance*1	θ _{JA}	TMSOP-8	Board A	-	160	-	°C/W
			Board B	-	133	-	°C/W
			Board C	-	-	-	°C/W
			Board D	-	-	-	°C/W
			Board E	-	-	-	°C/W

*1. Test environment: compliance with JEDEC STANDARD JESD51-2A

Remark Refer to "■ Power Dissipation" and "Test Board" for details.

■ Electrical Characteristics

1. Recommended operation conditions

Table 6

(Ta = -40°C to +125°C unless otherwise specified)

Item	Symbol	Condition	Min.	Typ.	Max.	Unit	Test Circuit
Operation power supply voltage range	V _{DD}	–	4.0	–	36.0	V	–

2. V_{DD} = 5.0 V

Table 7

(Ta = -40°C to +125°C unless otherwise specified)

DC Electrical Characteristics

Item	Symbol	Condition	Min.	Typ.	Max.	Unit	Test Circuit
Current consumption (2 circuits)	I _{DD}	V _{CMR} = V _{OUT} = $\frac{V_{DD}}{2}$	–	500	760	μA	5
Input offset voltage	V _{IO}	V _{CMR} = $\frac{V_{DD}}{2}$	-50	±10	+50	μV	1
Input offset voltage drift	$\frac{\Delta V_{IO}}{\Delta T_a}$	V _{CMR} = $\frac{V_{DD}}{2}$	-125	±30	+125	nV/°C	1
Input bias current	I _{BIAS}	–	–	3	10	nA	9,10
Input offset current	I _{IO}	–	–	3	10	nA	9,10
Common-mode input voltage range	V _{CMR}	–	V _{SS}	–	V _{DD}	V	2
Voltage gain (open loop)	A _{VOL}	V _{SS} + 0.5 V ≤ V _{OUT} ≤ V _{DD} - 0.5 V, V _{CMR} = $\frac{V_{DD}}{2}$, R _L = 10 kΩ	93	110	–	dB	8
Maximum output swing voltage	V _{OH}	I _{SOURCE} = 100 μA	4.9	–	–	V	3
		I _{SOURCE} = 1 mA	4.7	–	–	V	3
	V _{OL}	I _{SINK} = 100 μA	–	–	0.1	V	4
		I _{SINK} = 1 mA	–	–	0.3	V	4
Common-mode input signal rejection ratio	CMRR	V _{SS} ≤ V _{CMR} ≤ V _{DD}	93	110	–	dB	2
Power supply voltage rejection ratio	PSRR	4.0 V ≤ V _{DD} ≤ 36.0 V	116	130	–	dB	1
Source current	I _{SOURCE}	V _{OUT} = V _{DD} - 0.1 V	0.40	0.60	–	mA	6
Sink current	I _{SINK}	V _{OUT} = 0.1 V	0.25	0.50	–	mA	7
Output pin short-circuit current (source)	I _{SHORT_SOURCE}	V _{OUT} = 0 V	–	16.0	–	mA	–
Output pin short-circuit current (sink)	I _{SHORT_SINK}	V _{OUT} = V _{DD}	–	15.0	–	mA	–

Table 8

(Ta = -40°C to +125°C unless otherwise specified)

AC Electrical Characteristics

Item	Symbol	Condition	Min.	Typ.	Max.	Unit
Slew rate	SR	R _L = 1.0 MΩ, C _L = 15 pF (Refer to Figure 13 and Figure 14), V _{IN(+)} = 1.5 V ↔ 3.5 V	–	0.45	–	V/μs
Gain-bandwidth product	GBP	C _L = 0 pF	–	1.2	–	MHz
Maximum load capacitance	C _L	–	–	470	–	pF
Input noise voltage	V _{NOISE_pp}	f = 0.1 Hz to 10 Hz	–	0.8	–	μVpp
Input noise voltage density	V _{NOISE}	f = 1 kHz	–	25	–	nV/√Hz

3. $V_{DD} = 30.0\text{ V}$

Table 9

($T_a = -40^\circ\text{C}$ to $+125^\circ\text{C}$ unless otherwise specified)

DC Electrical Characteristics

Item	Symbol	Condition	Min.	Typ.	Max.	Unit	Test Circuit
Current consumption (2 circuits)	I_{DD}	$V_{CMR} = V_{OUT} = \frac{V_{DD}}{2}$	–	500	760	μA	5
Input offset voltage	V_{IO}	$V_{CMR} = \frac{V_{DD}}{2}$	–50	± 10	+50	μV	1
Input offset voltage drift	$\frac{\Delta V_{IO}}{\Delta T_a}$	$V_{CMR} = \frac{V_{DD}}{2}$	–120	± 25	+120	$\text{nV}/^\circ\text{C}$	1
Input bias current	I_{BIAS}	–	–	3	10	nA	9,10
Input offset current	I_{IO}	–	–	3	10	nA	9,10
Common-mode input voltage range	V_{CMR}	–	V_{SS}	–	V_{DD}	V	2
Voltage gain (open loop)	A_{VOL}	$V_{SS} + 0.5\text{ V} \leq V_{OUT} \leq V_{DD} - 0.5\text{ V}$, $V_{CMR} = \frac{V_{DD}}{2}$, $R_L = 10\text{ k}\Omega$	106	120	–	dB	8
Maximum output swing voltage	V_{OH}	$I_{SOURCE} = 100\ \mu\text{A}$	29.9	–	–	V	3
		$I_{SOURCE} = 1\text{ mA}$	29.7	–	–	V	3
	V_{OL}	$I_{SINK} = 100\ \mu\text{A}$	–	–	0.1	V	4
		$I_{SINK} = 1\text{ mA}$	–	–	0.3	V	4
Common-mode input signal rejection ratio	CMRR	$V_{SS} \leq V_{CMR} \leq V_{DD}$	106	120	–	dB	2
Power supply voltage rejection ratio	PSRR	$4.0\text{ V} \leq V_{DD} \leq 36.0\text{ V}$	116	130	–	dB	1
Source current	I_{SOURCE}	$V_{OUT} = V_{DD} - 0.1\text{ V}$	0.40	0.60	–	mA	6
Sink current	I_{SINK}	$V_{OUT} = 0.1\text{ V}$	0.25	0.50	–	mA	7
Output pin short-circuit current (source)	I_{SHORT_SOURCE}	$V_{OUT} = 0\text{ V}$	–	16.0	–	mA	–
Output pin short-circuit current (sink)	I_{SHORT_SINK}	$V_{OUT} = V_{DD}$	–	15.0	–	mA	–

Table 10

AC Electrical Characteristics (Ta = -40°C to +125°C unless otherwise specified)

Item	Symbol	Condition	Min.	Typ.	Max.	Unit
Slew rate	SR	R _L = 1.0 MΩ, C _L = 15 pF (Refer to Figure 13 and Figure 14), V _{IN(+)} = 14.0 V ↔ 16.0 V	–	0.45	–	V/μs
Gain-bandwidth product	GBP	C _L = 0 pF	–	1.2	–	MHz
Maximum load capacitance	C _L	–	–	470	–	pF
Input noise voltage	V _{NOISE_pp}	f = 0.1 Hz to 10 Hz	–	0.8	–	μVpp
Input noise voltage density	V _{NOISE}	f = 1 kHz	–	25	–	nV/√Hz

■ Test Circuits (Per circuit)

1. Power supply voltage rejection ratio, input offset voltage, input offset voltage drift

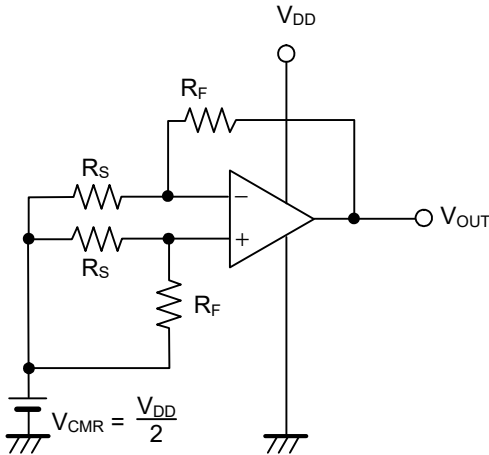

Figure 3 Test Circuit 1

• Power supply voltage rejection ratio (PSRR)

The power supply voltage rejection ratio (PSRR) can be calculated by the following expression, with V_{OUT} measured at each V_{DD} .

Test conditions:

$$V_{DD} = 4.0 \text{ V}: V_{DD} = V_{DD1}, V_{OUT} = V_{OUT1}$$

$$V_{DD} = 36.0 \text{ V}: V_{DD} = V_{DD2}, V_{OUT} = V_{OUT2}$$

$$PSRR = 20 \log \left(\left| \frac{V_{DD1} - V_{DD2}}{\left(V_{OUT1} - \frac{V_{DD1}}{2} \right) - \left(V_{OUT2} - \frac{V_{DD2}}{2} \right)} \right| \times \frac{R_F + R_S}{R_S} \right)$$

• Input offset voltage (V_{IO})

$$V_{IO} = \left(V_{OUT} - \frac{V_{DD}}{2} \right) \times \frac{R_S}{R_F + R_S}$$

• Input offset voltage drift $\left(\frac{\Delta V_{IO}}{\Delta T_a} \right)$

The input offset voltage drift $\left(\frac{\Delta V_{IO}}{\Delta T_a} \right)$ can be calculated by the following expression, with V_{OUT} measured at each temperature.

Test conditions:

$$T_a = -40^\circ\text{C}: V_{IO} = V_{IO1}$$

$$T_a = +125^\circ\text{C}: V_{IO} = V_{IO2}$$

$$\frac{\Delta V_{IO}}{\Delta T_a} = \frac{V_{IO2} - V_{IO1}}{+125^\circ\text{C} - (-40^\circ\text{C})}$$

2. Common-mode input signal rejection ratio, common-mode input voltage range

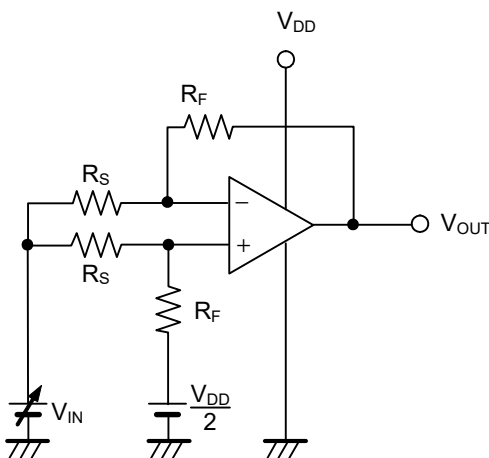

Figure 4 Test Circuit 2

• Common-mode input signal rejection ratio (CMRR)

The common-mode input signal rejection ratio (CMRR) can be calculated by the following expression, with V_{OUT} measured at each V_{IN} .

Test conditions:

$$V_{IN} = V_{CMR \text{ Max.}}: V_{IN} = V_{IN1}, V_{OUT} = V_{OUT1}$$

$$V_{IN} = V_{CMR \text{ Min.}}: V_{IN} = V_{IN2}, V_{OUT} = V_{OUT2}$$

$$CMRR = 20 \log \left(\left| \frac{V_{IN1} - V_{IN2}}{V_{OUT1} - V_{OUT2}} \right| \times \frac{R_F + R_S}{R_S} \right)$$

• Common-mode input voltage range (V_{CMR})

The common-mode input voltage range is the range of V_{IN} in which V_{OUT} satisfies the common-mode input signal rejection ratio specifications when V_{IN} is changed.

3. Maximum output swing voltage

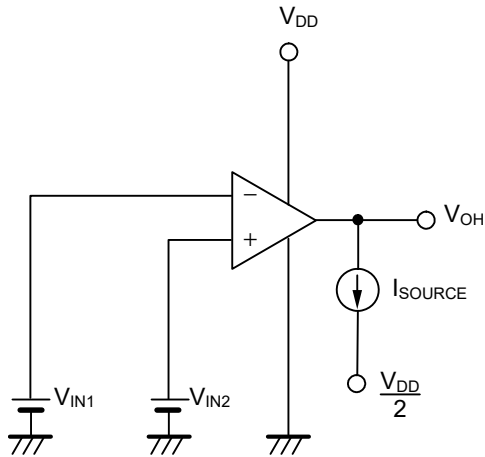

Figure 5 Test Circuit 3

• **Maximum output swing voltage (V_{OH})**

Test conditions:

$$V_{IN1} = \frac{V_{DD}}{2} - 0.1 \text{ V}$$

$$V_{IN2} = \frac{V_{DD}}{2} + 0.1 \text{ V}$$

$$I_{SOURCE} = 100 \mu\text{A}, 1 \text{ mA}$$

4. Maximum output swing voltage

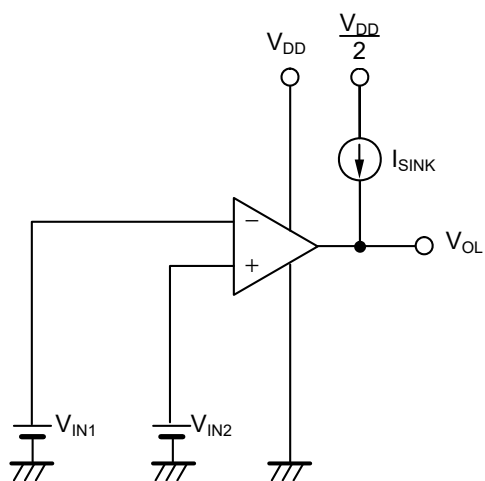

Figure 6 Test Circuit 4

• **Maximum output swing voltage (V_{OL})**

Test conditions:

$$V_{IN1} = \frac{V_{DD}}{2} + 0.1 \text{ V}$$

$$V_{IN2} = \frac{V_{DD}}{2} - 0.1 \text{ V}$$

$$I_{SINK} = 100 \mu\text{A}, 1 \text{ mA}$$

5. Current consumption

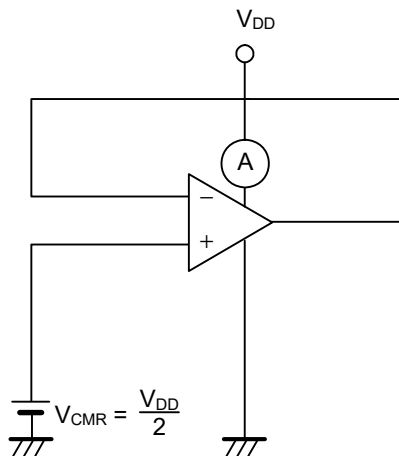

Figure 7 Test Circuit 5

• **Current consumption (I_{DD})**

6. Source current

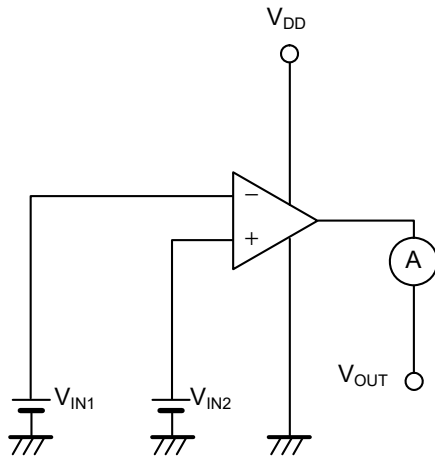

Figure 8 Test Circuit 6

• Source current (I_{SOURCE})

Test conditions:

$$V_{OUT} = V_{DD} - 0.1 \text{ V}$$

$$V_{IN1} = \frac{V_{DD}}{2} - 0.1 \text{ V}$$

$$V_{IN2} = \frac{V_{DD}}{2} + 0.1 \text{ V}$$

7. Sink current

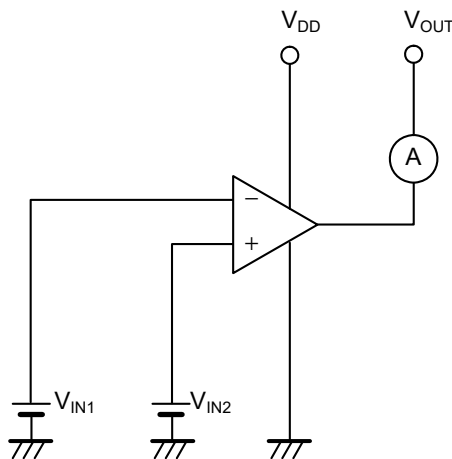

Figure 9 Test Circuit 7

• Sink current (I_{SINK})

Test conditions:

$$V_{OUT} = 0.1 \text{ V}$$

$$V_{IN1} = \frac{V_{DD}}{2} + 0.1 \text{ V}$$

$$V_{IN2} = \frac{V_{DD}}{2} - 0.1 \text{ V}$$

8. Voltage gain

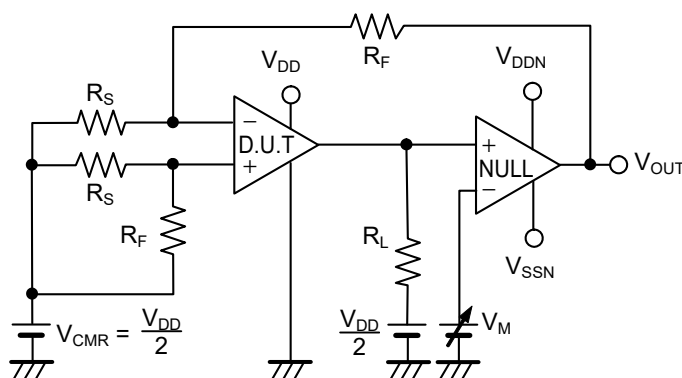

Figure 10 Test Circuit 8

• Voltage gain (open loop) (A_{VOL})

The voltage gain (A_{VOL}) can be calculated by the following expression, with V_{OUT} measured at each V_M .

Test conditions:

$$V_M = V_{DD} - 0.5 \text{ V}: V_M = V_{M1}, V_{OUT} = V_{OUT1}$$

$$V_M = V_{SS} + 0.5 \text{ V}: V_M = V_{M2}, V_{OUT} = V_{OUT2}$$

$$A_{VOL} = 20 \log \left(\left| \frac{V_{M1} - V_{M2}}{V_{OUT1} - V_{OUT2}} \right| \times \frac{R_F + R_S}{R_S} \right)$$

$$R_L = 10 \text{ k}\Omega$$

9. Input bias current, input offset current

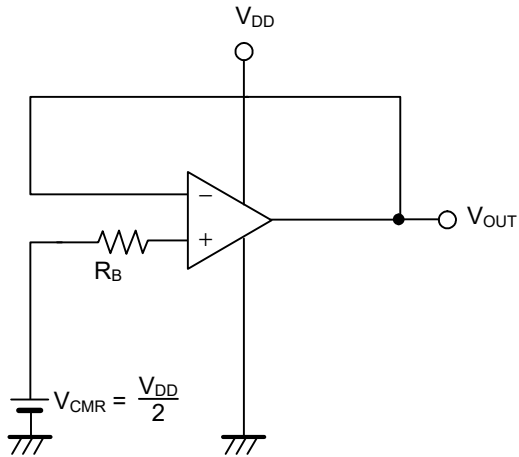

Figure 11 Test Circuit 9

• **Input bias current (I_{BIAS})**

Test conditions:

$$I_{BIAS(+)} = \frac{-1 \times (V_{OUT} - \frac{V_{DD}}{2})}{R_B}$$

$$I_{BIAS(-)} = \frac{V_{OUT} - \frac{V_{DD}}{2}}{R_B}$$

$$I_{BIAS} = \frac{|I_{BIAS(+)} + I_{BIAS(-)}|}{2}$$

• **Input offset current (I_{IO})**

$$I_{IO} = |I_{BIAS(-)} - I_{BIAS(+)}|$$

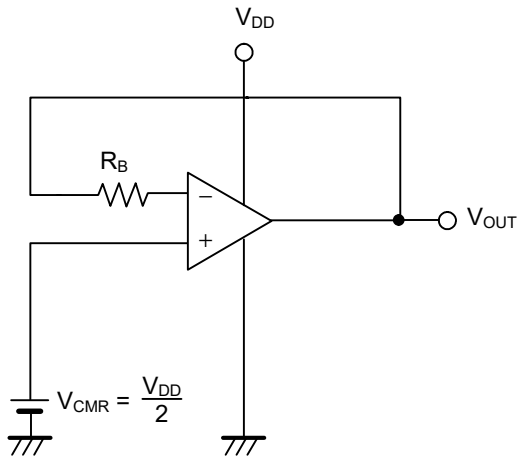

Figure 12 Test Circuit 10

10. Slew rate

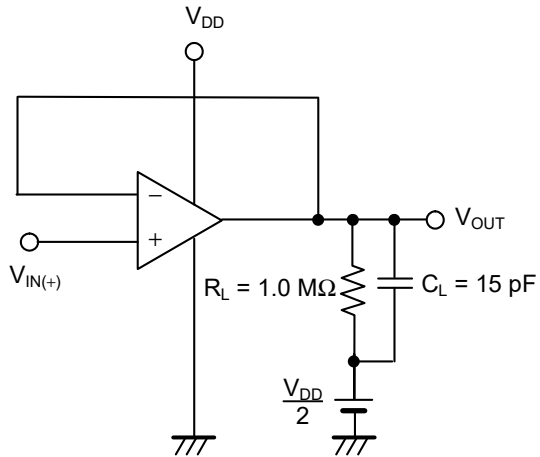

Figure 13 Test Circuit 11

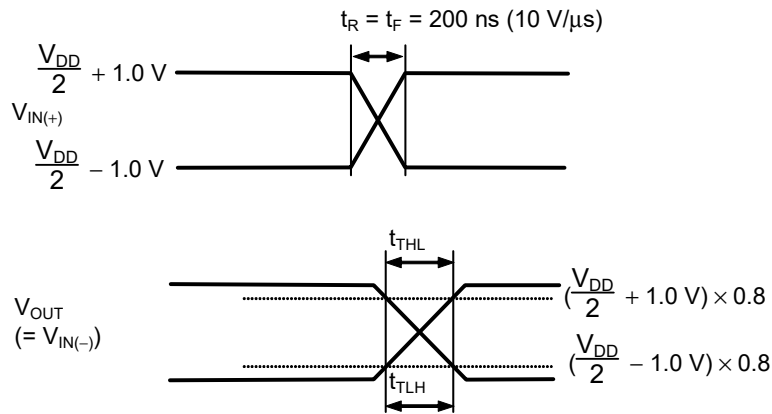

Figure 14

• Slew rate (SR)

When falling

$$SR = \frac{1.6 \text{ V}}{t_{THL}}$$

When rising

$$SR = \frac{1.6 \text{ V}}{t_{TLH}}$$

■ Precautions

- Generally an operational amplifier may cause oscillation depending on the selection of external parts. Perform thorough evaluation using the actual application to set the constants.
- Do not apply an electrostatic discharge to this IC that exceeds performance ratings of the built-in electrostatic protection circuit.
- ABLIC Inc. claims no responsibility for any disputes arising out of or in connection with any infringement by products including this IC of patents owned by a third party.
- This IC operates stably even directly connecting a load capacitance of 470 pF or less to the output pin, as shown in **Figure 15**. When connecting a load capacitance of 470 pF or more, connect a resistor of 100 Ω or more as shown in **Figure 16**. In case of connecting a filter for noise prevention, and connecting a load capacitance of 470 pF or more, also connect a resistor of 100 Ω or more as shown in **Figure 17**.

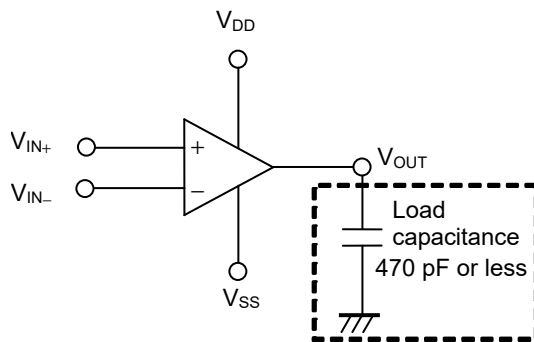

Figure 15

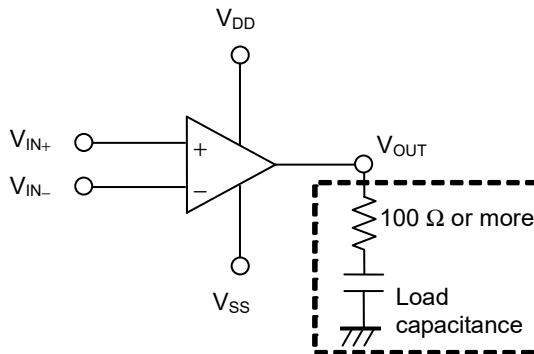

Figure 16

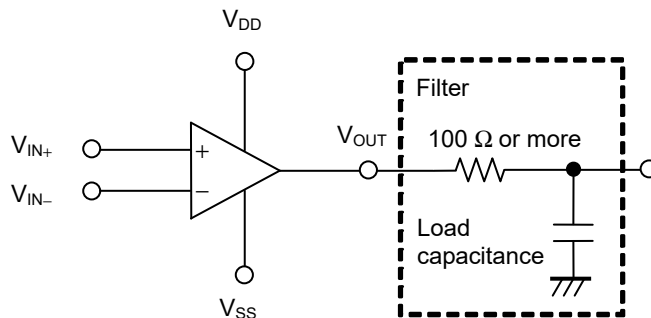

Figure 17

Caution The above connection diagrams and constants will not guarantee successful operation. Perform thorough evaluation using the actual application to set the constants.

■ Precaution for use

1. Methods for protection against application of overvoltage to input pin

ESD protection elements are connected to the input pins as shown in **Figure 1**. If the input voltage (V_{IN}) exceeds the V_{IN} absolute maximum rating $V_{DD} + 0.3$ V, there is a risk of the input pin current which flows through the ESD protection element exceeding ± 10.0 mA (the absolute maximum rating). In this case, connect a current limiting resistor (R_{LIMIT}) to the input pin as shown in **Figure 18** to limit the input pin current to less than ± 10.0 mA. However, error voltage and noise generate as a result of input bias current and input offset current. Select the lowest possible resistance when connecting the R_{LIMIT} .

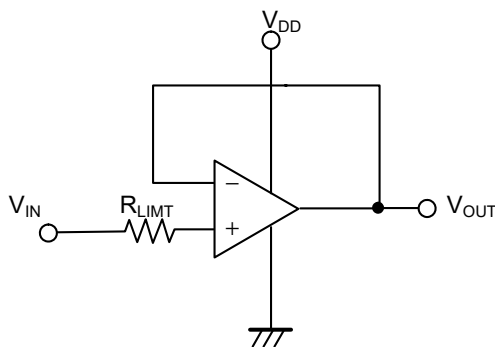

Figure 18

2. Input voltage range (input crossover distortion)

This IC has two sets of differential circuits in order to achieve the Rail-to-Rail input voltage range. The differential circuits used switch based on the common-mode input voltage range (V_{CMR}). Differences in the characteristics of the two sets of differential circuits result in the generation of distortion of the output voltage which is referred to as "input crossover distortion" when the differential circuits switch.

The differential circuit switching voltage of this IC is approximately between $V_{DD} - 2.2$ V and $V_{DD} - 1.2$ V. When using this IC in applications which require high-accuracy measurement, avoid the range near the differential circuit switching voltage in order to avoid changes in input offset voltage caused by input crossover distortion and changes in input offset voltage drift.

This IC is a chopper-stabilized zero-drift amplifier; therefore, it always cancels input offset voltage. For this reason, the input crossover distortion is kept extremely small when compared to standard operational amplifiers. However, please contact our sales representatives when using this IC near the differential circuit switching voltage.

Refer to "8. Input offset voltage (V_{IO}) vs. Common-mode input voltage range (V_{CMR})" in "■ Characteristics (Typical Data)".

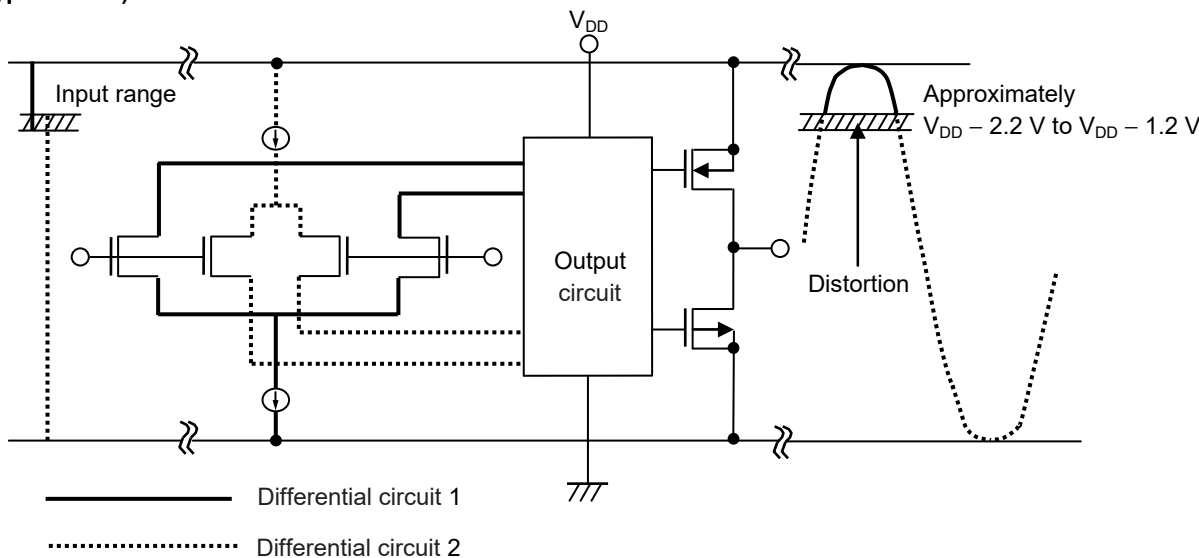

Figure 19

3. Recommended processing methods for unused circuit

When using only a single circuit of this IC, it is recommended that the unused circuit be connected as shown in **Figure 20**. Set the non-inverted input pin voltage ($V_{IN(+)}$) within the common-mode input voltage range (V_{CMR}).

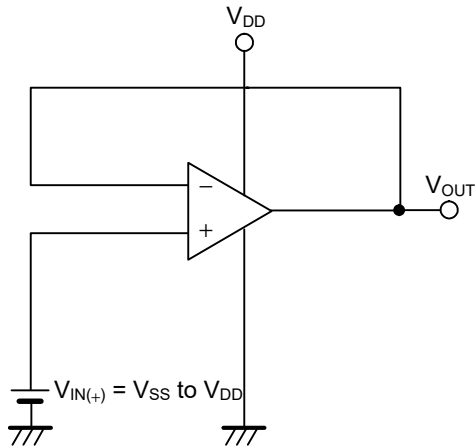
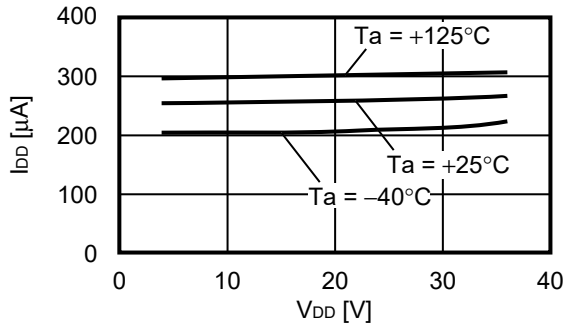

Figure 20

■ **Characteristics (Typical Data)**

1. **Current consumption (I_{DD}) (Per circuit) vs. Power supply voltage (V_{DD})**



2. **Voltage gain (A_{VOL}) vs. Frequency (f)**

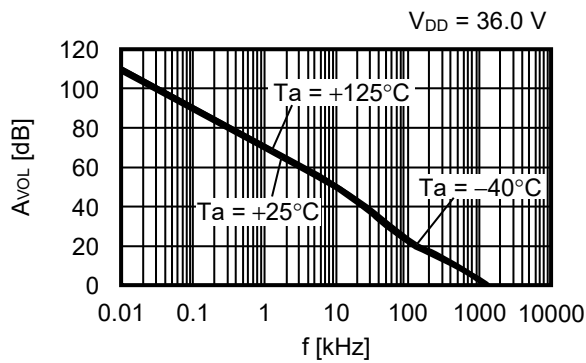
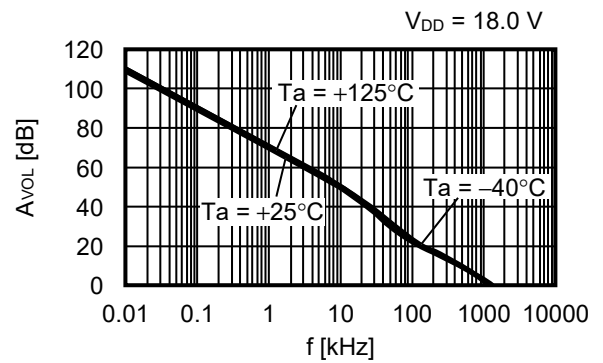
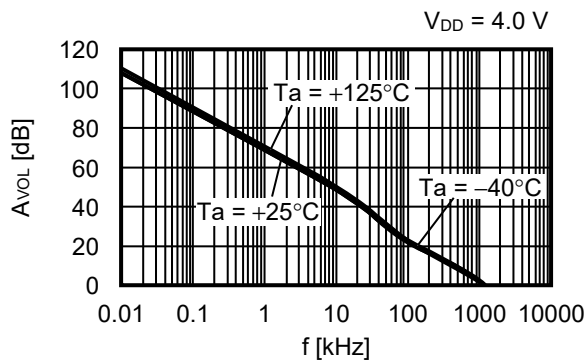

3. Output current

3.1 Source current (I_{SOURCE}) vs. Power supply voltage (V_{DD})

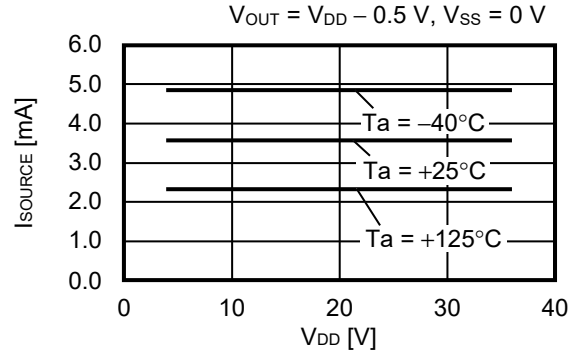
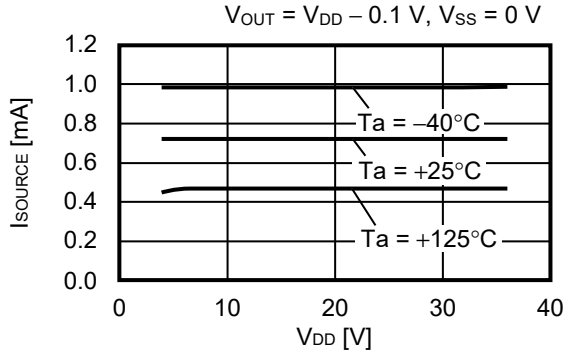

3.2 Sink current (I_{SINK}) vs. Power supply voltage (V_{DD})

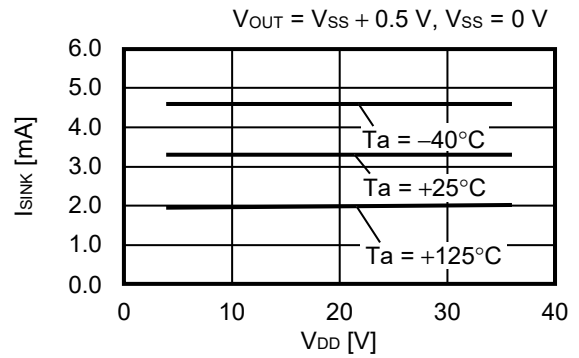
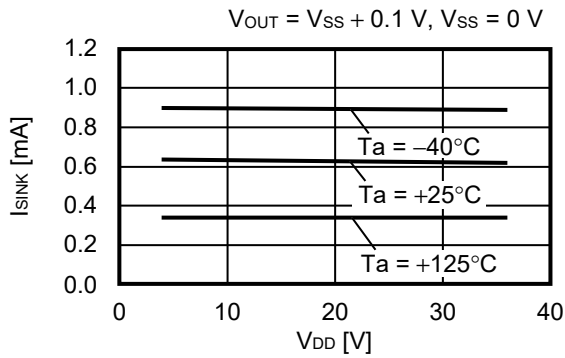

3.3 Output voltage (V_{OUT}) vs. Source current (I_{SOURCE})

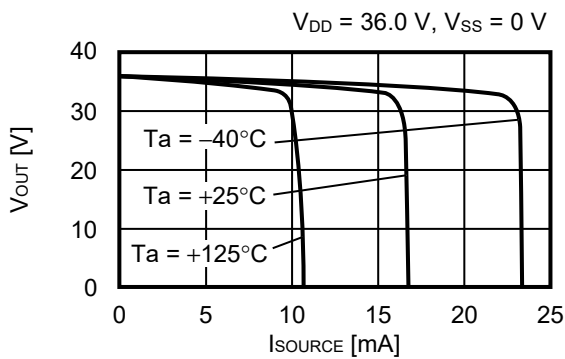
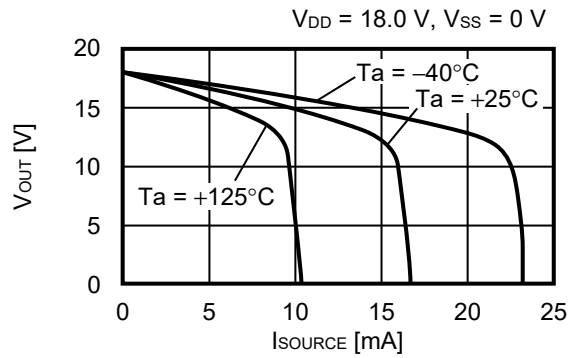
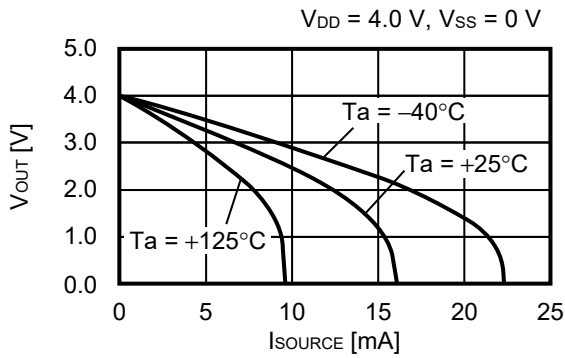

3. 4 Output voltage (V_{OUT}) vs. Sink current (I_{SINK})

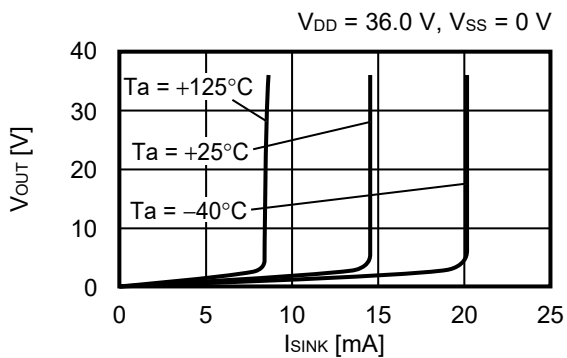
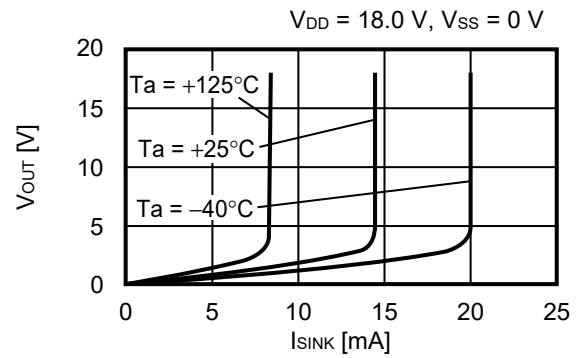
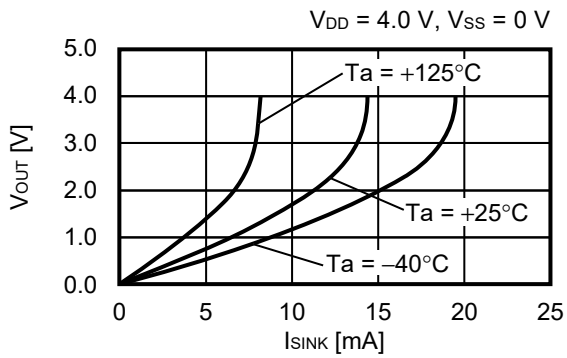

4. Input bias current (I_{BIAS}) vs. Temperature (Ta)

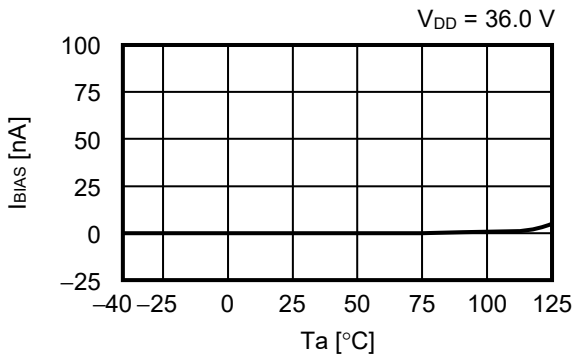

5. Input noise voltage density (V_{NOISE}) vs. Frequency (f)

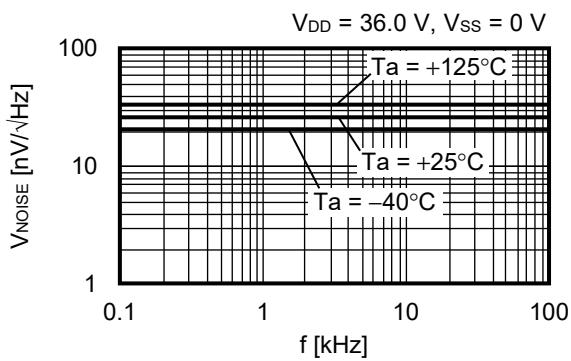
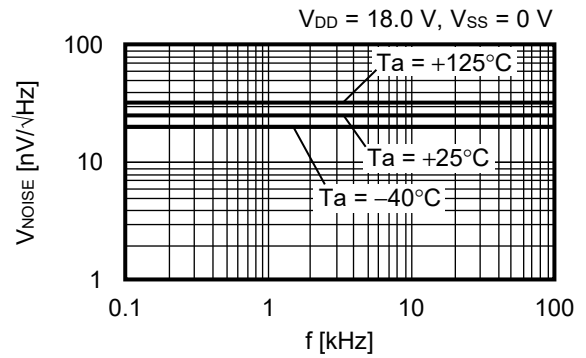
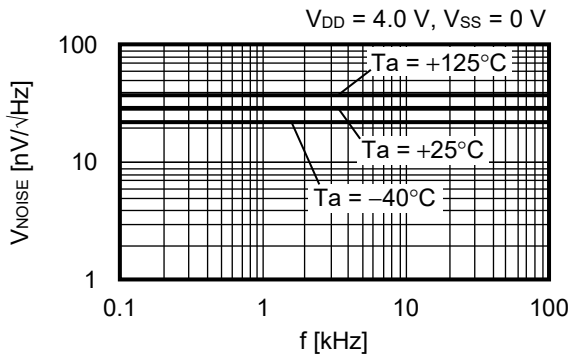

6. Input pin current (I_{IN}) vs. Differential input voltage (V_{IND})

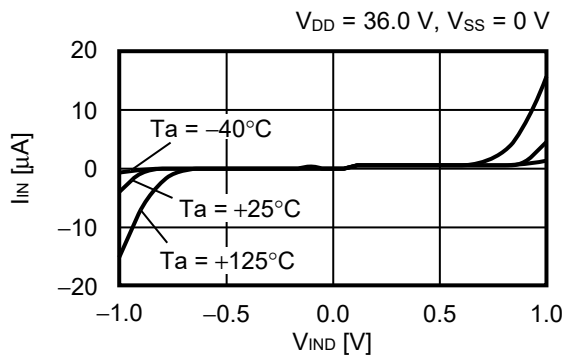

7. Input offset voltage (V_{IO}) vs. Power supply voltage (V_{DD})

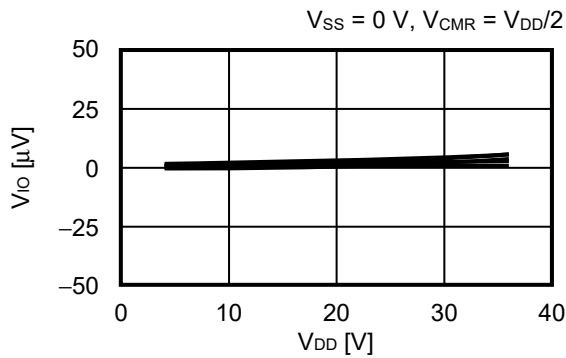

Remark Measured six samples

8. Input offset voltage (V_{IO}) vs. Common-mode input voltage range (V_{CMR})

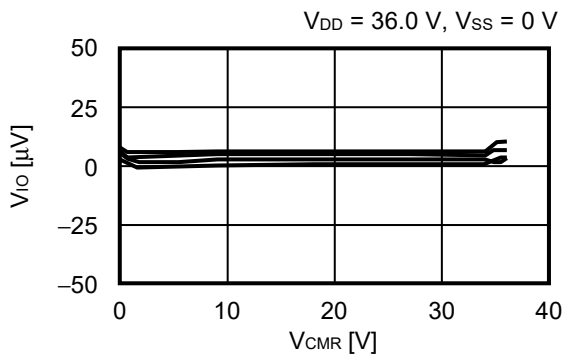
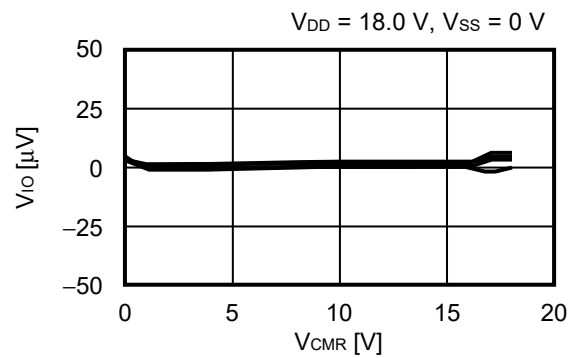
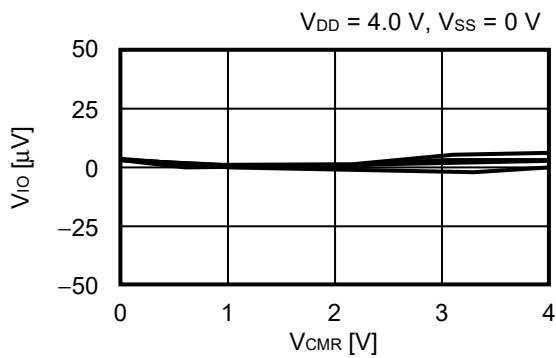

Remark Measured four samples

9. Voltage gain (open loop) (A_{VOL}) vs. Temperature (T_a)

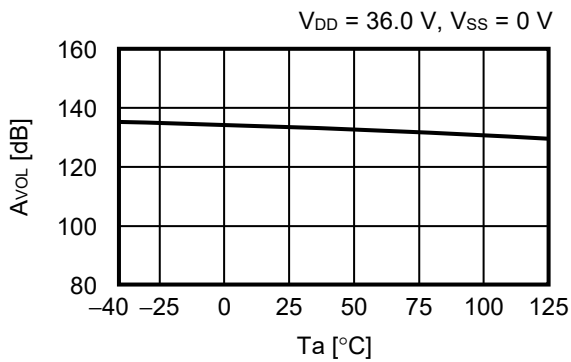
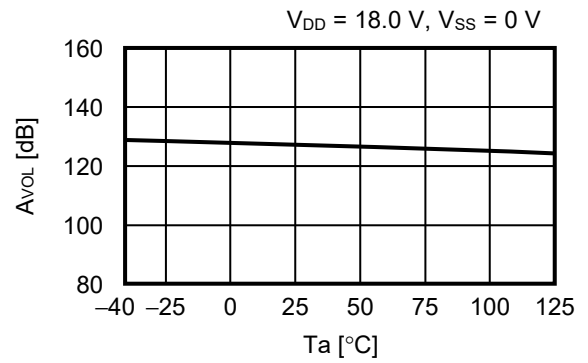
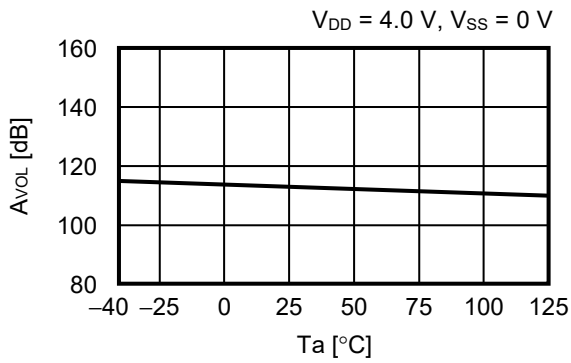

10. Power supply voltage rejection ratio (PSRR) vs. Temperature (T_a)

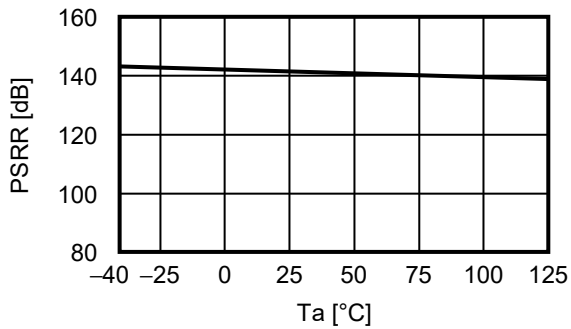

11. Common-mode input signal rejection ratio (CMRR) vs. Temperature (Ta)

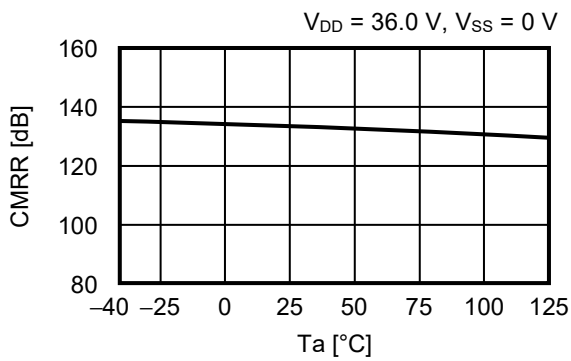
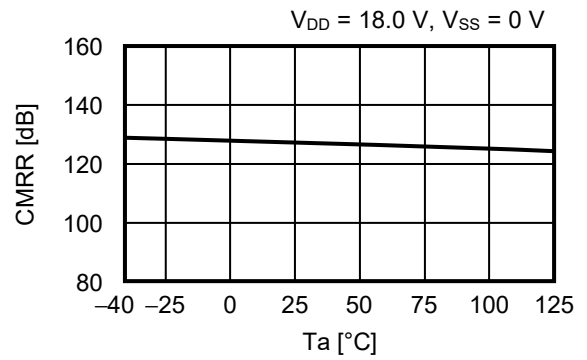
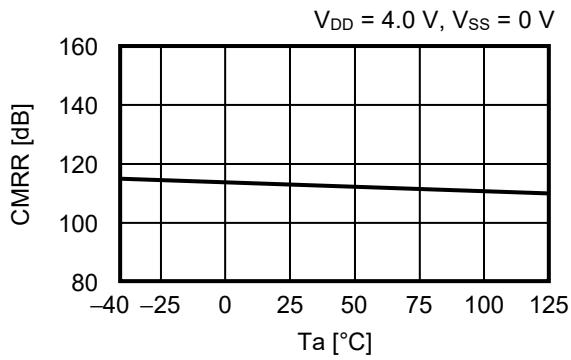

12. Step response (Slew rate)

12.1 Input signal width (0.4 V)

12.1.1 $V_{IN(+)} = 1.8\text{ V} \leftrightarrow 2.2\text{ V}$

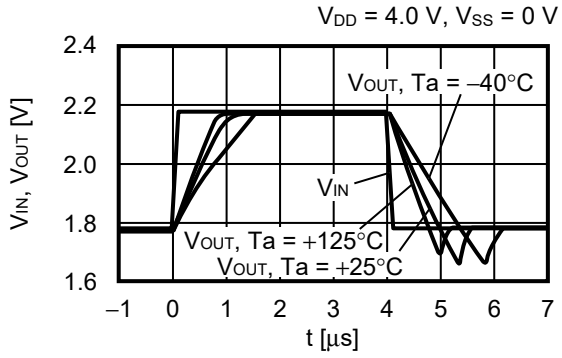

12.1.2 $V_{IN(+)} = 8.8\text{ V} \leftrightarrow 9.2\text{ V}$

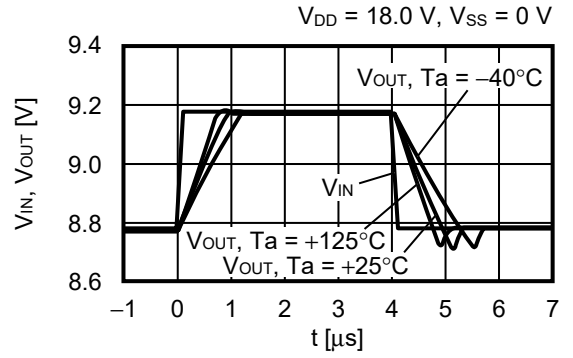

12.1.3 $V_{IN(+)} = 17.8\text{ V} \leftrightarrow 18.2\text{ V}$

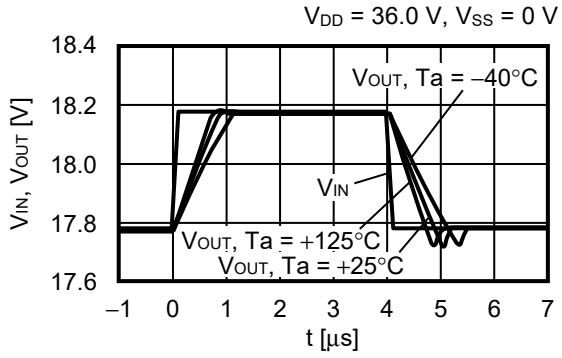

12.2 Input signal width (4.0 V)

12.2.1 $V_{IN(+)} = 0\text{ V} \leftrightarrow 4.0\text{ V}$

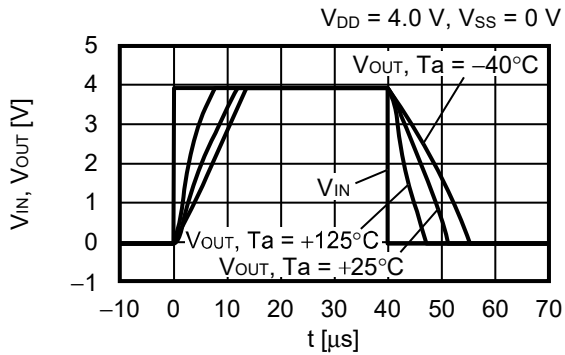

12.2.2 $V_{IN(+)} = 7.0\text{ V} \leftrightarrow 11.0\text{ V}$

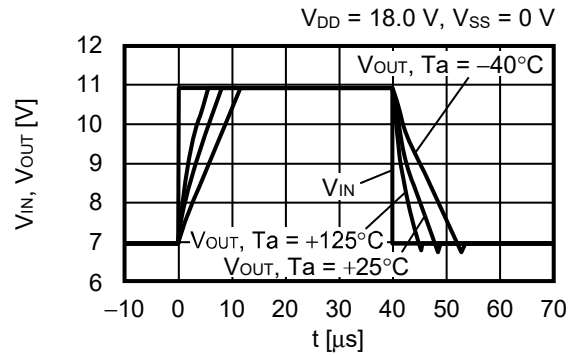

12.2.3 $V_{IN(+)} = 16.0\text{ V} \leftrightarrow 20.0\text{ V}$

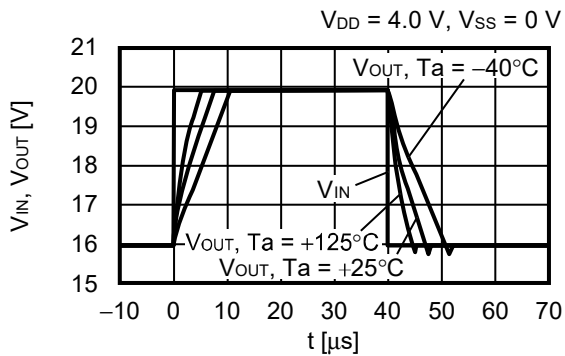

12.3 Input signal width ($V_{SS} \leftrightarrow V_{DD}$)

12.3.1 $V_{IN(+)} = 0\text{ V} \leftrightarrow 18.0\text{ V}$

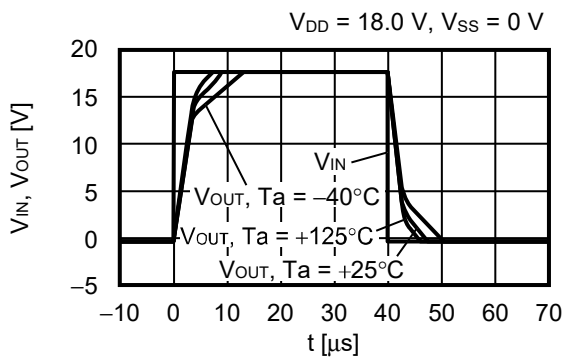

12.3.2 $V_{IN(+)} = 0\text{ V} \leftrightarrow 36.0\text{ V}$

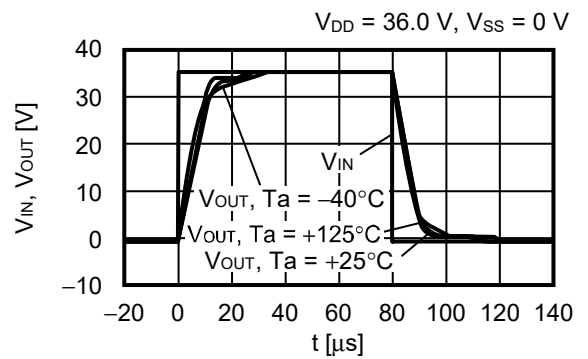

13. Input offset voltage distribution

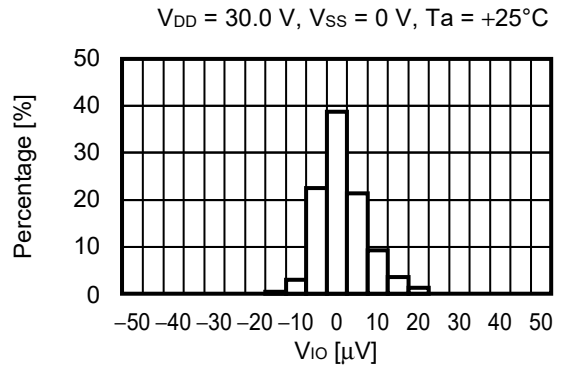
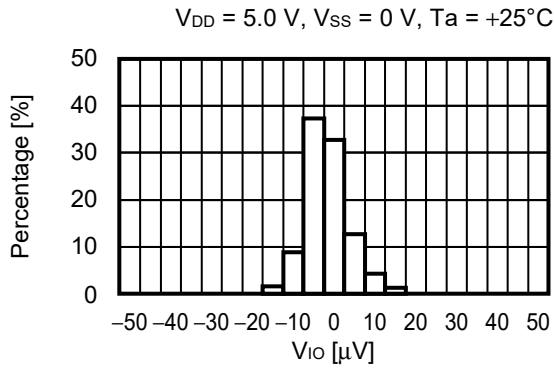

14. Input offset voltage drift distribution

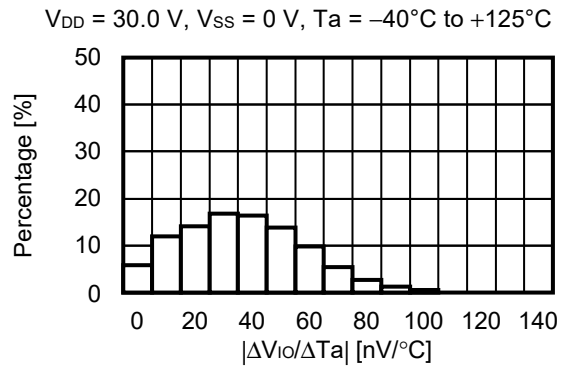
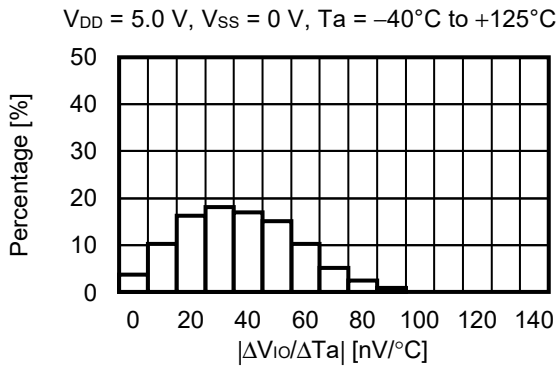

■ Power Dissipation

TMSOP-8

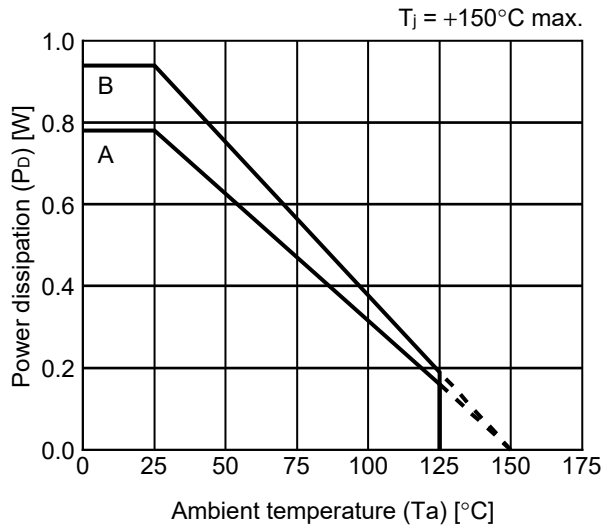

Board	Power Dissipation (P_D)
A	0.78 W
B	0.94 W
C	–
D	–
E	–

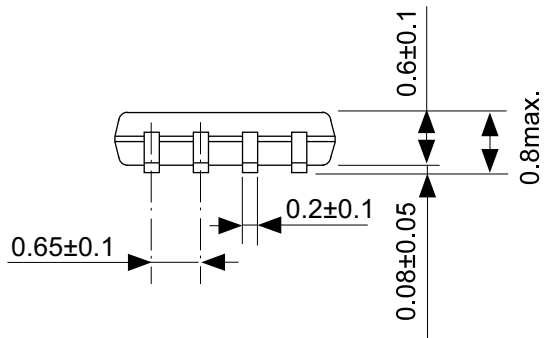
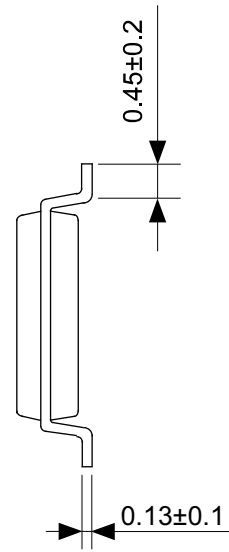
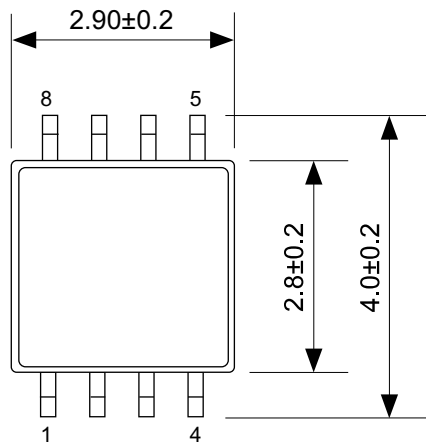

No. FM008-A-P-SD-1.2

TITLE	TMSOP8-A-PKG Dimensions
No.	FM008-A-P-SD-1.2
ANGLE	
UNIT	mm
ABLIC Inc.	

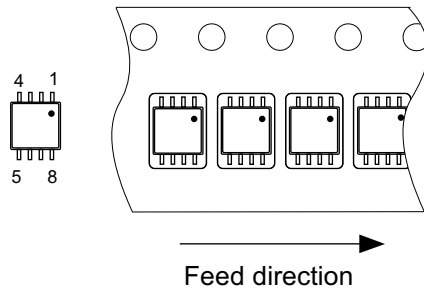
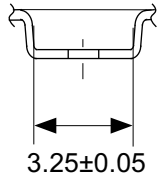
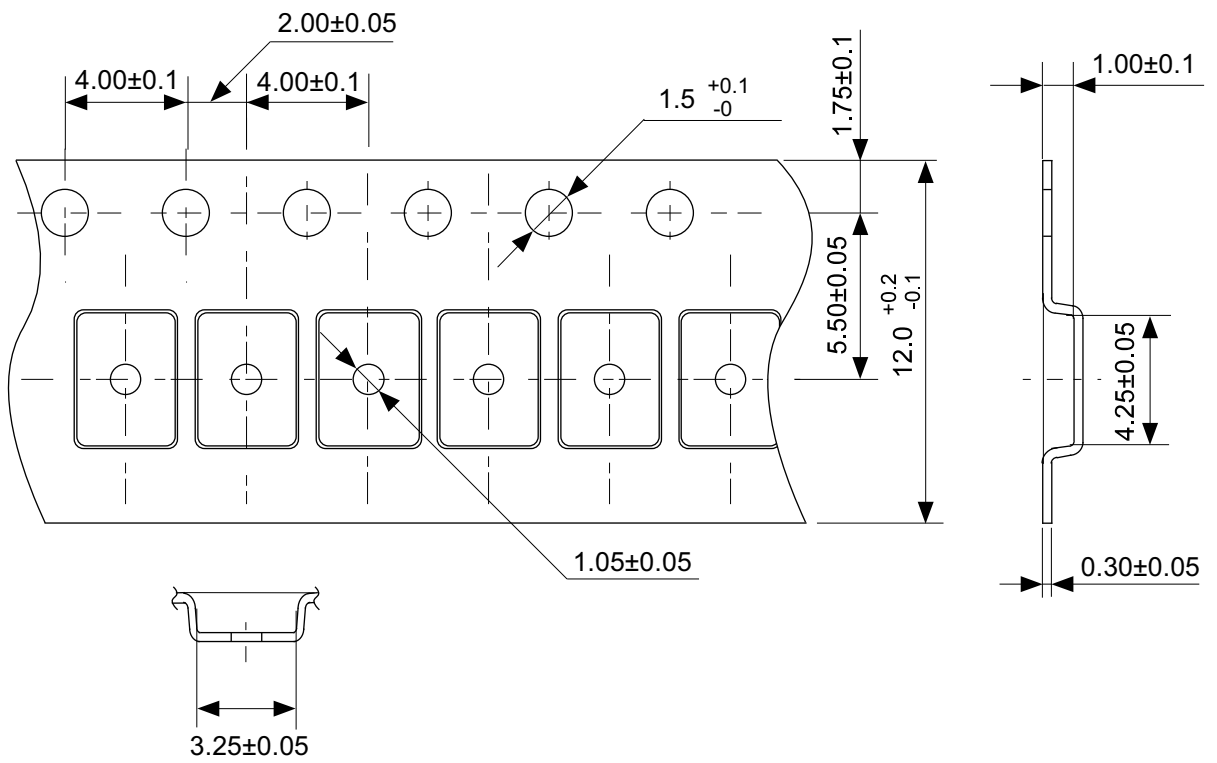

No. FM008-A-C-SD-2.0

TITLE	TMSOP8-A-Carrier Tape
No.	FM008-A-C-SD-2.0
ANGLE	
UNIT	mm
ABLIC Inc.	

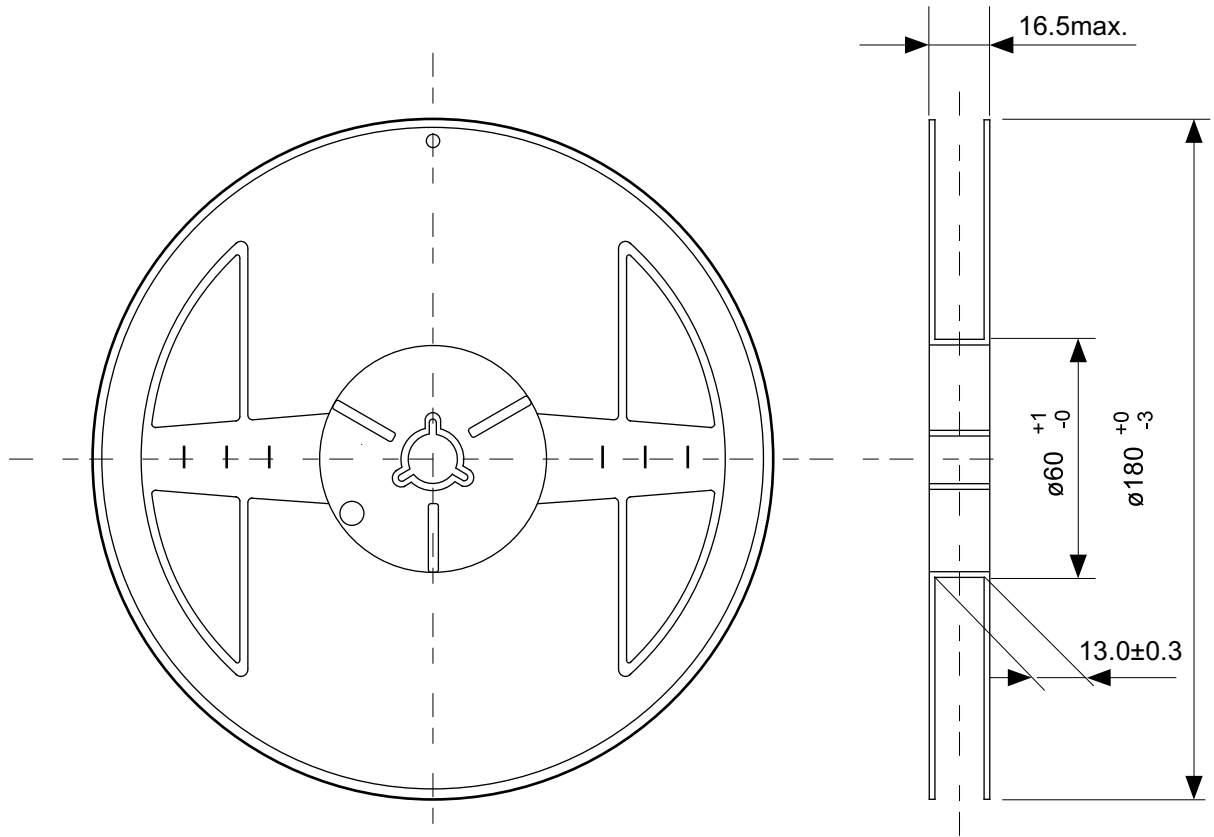

Enlarged drawing in the central part

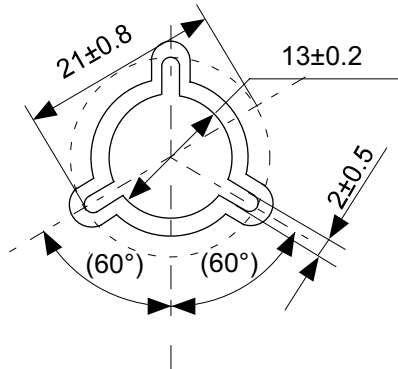

No. FM008-A-R-SD-1.0

TITLE	TMSOP8-A-Reel		
No.	FM008-A-R-SD-1.0		
ANGLE		QTY.	4,000
UNIT	mm		
ABLIC Inc.			

Disclaimers (Handling Precautions)

1. All the information described herein (product data, specifications, figures, tables, programs, algorithms and application circuit examples, etc.) is current as of publishing date of this document and is subject to change without notice.
2. The circuit examples and the usages described herein are for reference only, and do not guarantee the success of any specific mass-production design.
ABLIC Inc. is not liable for any losses, damages, claims or demands caused by the reasons other than the products described herein (hereinafter "the products") or infringement of third-party intellectual property right and any other right due to the use of the information described herein.
3. ABLIC Inc. is not liable for any losses, damages, claims or demands caused by the incorrect information described herein.
4. Be careful to use the products within their ranges described herein. Pay special attention for use to the absolute maximum ratings, operation voltage range and electrical characteristics, etc.
ABLIC Inc. is not liable for any losses, damages, claims or demands caused by failures and / or accidents, etc. due to the use of the products outside their specified ranges.
5. Before using the products, confirm their applications, and the laws and regulations of the region or country where they are used and verify suitability, safety and other factors for the intended use.
6. When exporting the products, comply with the Foreign Exchange and Foreign Trade Act and all other export-related laws, and follow the required procedures.
7. The products are strictly prohibited from using, providing or exporting for the purposes of the development of weapons of mass destruction or military use. ABLIC Inc. is not liable for any losses, damages, claims or demands caused by any provision or export to the person or entity who intends to develop, manufacture, use or store nuclear, biological or chemical weapons or missiles, or use any other military purposes.
8. The products are not designed to be used as part of any device or equipment that may affect the human body, human life, or assets (such as medical equipment, disaster prevention systems, security systems, combustion control systems, infrastructure control systems, vehicle equipment, traffic systems, in-vehicle equipment, aviation equipment, aerospace equipment, and nuclear-related equipment), excluding when specified for in-vehicle use or other uses by ABLIC, Inc. Do not apply the products to the above listed devices and equipments.
ABLIC Inc. is not liable for any losses, damages, claims or demands caused by unauthorized or unspecified use of the products.
9. In general, semiconductor products may fail or malfunction with some probability. The user of the products should therefore take responsibility to give thorough consideration to safety design including redundancy, fire spread prevention measures, and malfunction prevention to prevent accidents causing injury or death, fires and social damage, etc. that may ensue from the products' failure or malfunction.
The entire system in which the products are used must be sufficiently evaluated and judged whether the products are allowed to apply for the system on customer's own responsibility.
10. The products are not designed to be radiation-proof. The necessary radiation measures should be taken in the product design by the customer depending on the intended use.
11. The products do not affect human health under normal use. However, they contain chemical substances and heavy metals and should therefore not be put in the mouth. The fracture surfaces of wafers and chips may be sharp. Be careful when handling these with the bare hands to prevent injuries, etc.
12. When disposing of the products, comply with the laws and ordinances of the country or region where they are used.
13. The information described herein contains copyright information and know-how of ABLIC Inc. The information described herein does not convey any license under any intellectual property rights or any other rights belonging to ABLIC Inc. or a third party. Reproduction or copying of the information from this document or any part of this document described herein for the purpose of disclosing it to a third-party is strictly prohibited without the express permission of ABLIC Inc.
14. For more details on the information described herein or any other questions, please contact ABLIC Inc.'s sales representative.
15. This Disclaimers have been delivered in a text using the Japanese language, which text, despite any translations into the English language and the Chinese language, shall be controlling.

2.4-2019.07

Mouser Electronics

Authorized Distributor

Click to View Pricing, Inventory, Delivery & Lifecycle Information:

[ABLIC:](#)

[S-89630AB0A-K8T2U](#)

Компания «Океан Электроники» предлагает заключение долгосрочных отношений при поставках импортных электронных компонентов на взаимовыгодных условиях!

Наши преимущества:

- Поставка оригинальных импортных электронных компонентов напрямую с производств Америки, Европы и Азии, а так же с крупнейших складов мира;
- Широкая линейка поставок активных и пассивных импортных электронных компонентов (более 30 млн. наименований);
- Поставка сложных, дефицитных, либо снятых с производства позиций;
- Оперативные сроки поставки под заказ (от 5 рабочих дней);
- Экспресс доставка в любую точку России;
- Помощь Конструкторского Отдела и консультации квалифицированных инженеров;
- Техническая поддержка проекта, помощь в подборе аналогов, поставка прототипов;
- Поставка электронных компонентов под контролем ВП;
- Система менеджмента качества сертифицирована по Международному стандарту ISO 9001;
- При необходимости вся продукция военного и аэрокосмического назначения проходит испытания и сертификацию в лаборатории (по согласованию с заказчиком);
- Поставка специализированных компонентов военного и аэрокосмического уровня качества (Xilinx, Altera, Analog Devices, Intersil, Interpoint, Microsemi, Actel, Aeroflex, Peregrine, VPT, Syfer, Eurofarad, Texas Instruments, MS Kennedy, Miteq, Cobham, E2V, MA-COM, Hittite, Mini-Circuits, General Dynamics и др.);

Компания «Океан Электроники» является официальным дистрибьютором и эксклюзивным представителем в России одного из крупнейших производителей разъемов военного и аэрокосмического назначения «JONHON», а так же официальным дистрибьютором и эксклюзивным представителем в России производителя высокотехнологичных и надежных решений для передачи СВЧ сигналов «FORSTAR».



JONHON

«JONHON» (основан в 1970 г.)

Разъемы специального, военного и аэрокосмического назначения:

(Применяются в военной, авиационной, аэрокосмической, морской, железнодорожной, горно- и нефтедобывающей отраслях промышленности)

«FORSTAR» (основан в 1998 г.)

ВЧ соединители, коаксиальные кабели,
кабельные сборки и микроволновые компоненты:

(Применяются в телекоммуникациях гражданского и специального назначения, в средствах связи, РЛС, а так же военной, авиационной и аэрокосмической отраслях промышленности).



Телефон: 8 (812) 309-75-97 (многоканальный)

Факс: 8 (812) 320-03-32

Электронная почта: ocean@oceanchips.ru

Web: <http://oceanchips.ru/>

Адрес: 198099, г. Санкт-Петербург, ул. Калинина, д. 2, корп. 4, лит. А