

HIP2103_4DEMO2Z

Evaluation Board

AN9853
Rev 0.00
Jul 1999

Description

The HI5x60EVAL1 evaluation board provides a quick and easy method for evaluating the HI5860/5960 (12- or 14-bit), 125MSPS high speed DACs. The board is configured so that the converter outputs differential current into a transformer circuit to form an output voltage. The amount of current out of the DAC is determined by an external resistor and either an internal or external reference voltage. The CMOS digital inputs have optional external termination resistors. The evaluation board includes a VME digital interface that is compatible with all previous Intersil D/A evaluation boards.

Features

- 125MSPS 12- or 14-Bit CMOS DAC
- Also Can Be Used to Evaluate the 8- and 10-Bit Versions, the HI5660 and HI5760
- Transformer-Coupled or Single-Ended SMA Outputs
- Easily Selectable Internal or External Reference

Ordering Information

PART NUMBER	TEMP. RANGE (°C)	PACKAGE	NUMBER OF BITS	CLOCK SPEED
HI5860SOICEVAL1	25	SOIC	12	125MHz
HI5960SOICEVAL1	25	SOIC	14	125MHz

Functional Block Diagram

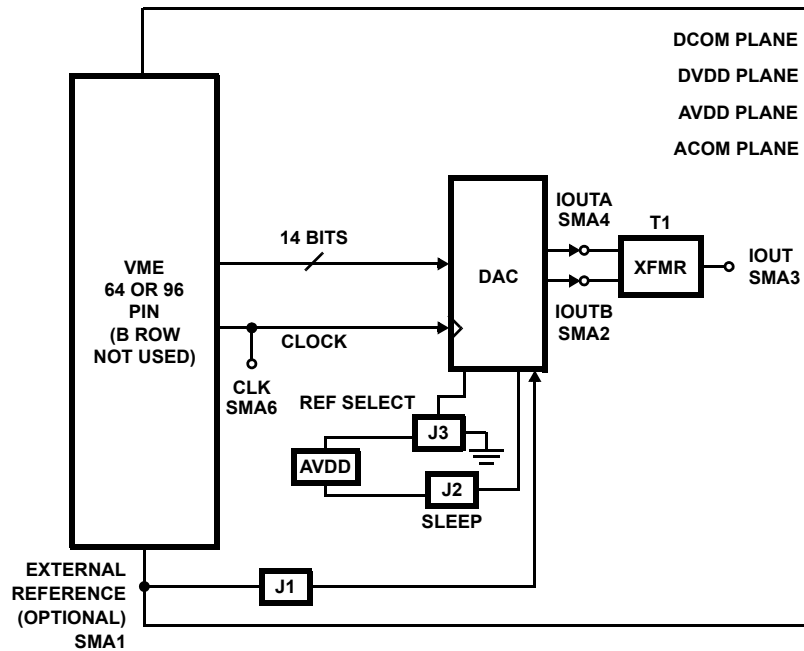

Functional Descriptions

Voltage Reference

The HI5860/5960 has an internal 1.2V voltage reference with a ± 40 ppm/°C drift coefficient over the industrial temperature range. The REFLO pin (16) selects the reference. Access to pin 16 is provided through the center pin of Jumper J3. This jumper is labeled INT and EXT for internal or external reference. The REFIO pin (17) provides access to the internal voltage reference, or can be overdriven if the user wishes to use an external source for the reference. The internal reference was not designed to drive an external load. Notice that a 0.1 μ F capacitor is placed as close as possible to the REFIO pin. This capacitor is necessary for ensuring a noise free reference voltage. If the user wishes to use an external reference voltage, jumper J1 must be in place and an external voltage reference provided via SMA1, labeled 'EXT REF'. The recommended limits of the external reference are between 15mV and 1.2V. Performance of the converter can be expected to decline as the reference voltage is reduced due to the reduction in LSB current size. If the user wishes to amplitude modulate the DAC, the REFIO pin can be overdriven with a waveform. The input multiplying bandwidth of the REFIO input is approximately 1.4MHz when driving a 100mV signal into the REFIO pin, biased at 0.6V_{DC}. The 3dB BW reduces as this amplitude is increased. It is necessary that the multiplying signal be DC offset so that the minimum and maximum peaks are positive and below 1.2V. For the external reference option, Jumper J3 must be changed so that pin 16 of the DAC is tied to the supply voltage, which is the EXT side of J3. The output current of the converter, IOUTA and IOUTB, is a function of the voltage reference used and the value of R_{SET} (or R2) on the schematic.

Output Current

The output current of the device is set by choosing R_{SET} and V_{FSADJ} such that the resultant of the following equation is less than 20mA:

$$I_{OUT} = 32 \times V_{FSADJ} / R_{SET}$$

REFIO (PIN 17) and FSADJ (PIN 18) of the DAC are the inputs to an operational amplifier. The voltage at the FSADJ pin (V_{FSADJ}) will be approximately equal to the voltage at the REFIO pin, which will either be the value of the internal or external reference. For example, using the internal reference of (nominal) 1.2V and an R_{SET} value of 1.91k Ω results in an I_{OUT} of approximately 20mA (maximum allowed). Choose the output loading so that the Output Voltage Compliance Range is not violated (-0.3 to 1.25V). If an external reference is chosen, it should not exceed +1.2V.

The output can be configured to drive a load resistor, a transformer, an operational amplifier, or any other type of output configuration so long as the output voltage compliance range and the maximum output current are not violated.

Transformer Output

The evaluation board is configured with a transformer output configuration, shown in Figure 1. This configuration was chosen because it provides: even harmonic performance improvement due to the differential signaling; $\sim 12.5\Omega$ R_{EQ} loading to each output of the DAC; drive impedance of 50 Ω for matching with a spectrum analyzer; and 2x voltage gain. The output of this configuration will be biased at zero volts and have an amplitude of ~ 500 mV (V_{OUT}) when the DAC is configured to drive I_{OUTFS} of 20mA.

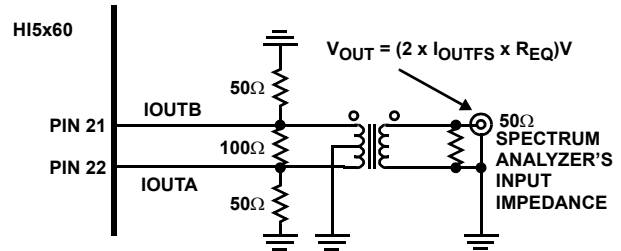

FIGURE 1.

Sleep

The converter can be put into 'sleep' mode by connecting pin 15 of the DAC to either of the converter's supply voltages. The sleep pin has an active pulldown current, so the pin can be left disconnected or be grounded for normal (awake) operation. On the evaluation board, jumper J2 is provided for controlling the sleep pin. Remove the jumper from J2 for normal operation and replace it for sleep mode.

Power Supply(ies) and Ground(s)

The user can operate from either a single supply or from dual supplies. The supplies can be at different voltages. It is important to note that the digital inputs cannot switch more than 0.3V above the digital supply voltage. The evaluation board contains two power supply connections, (analog) AV_{DD1} and (digital) DV_{DD1}, each with their own ground wire. Dual ground and power planes is the recommended configuration, with the ground planes connected at a single point near the DAC.

Digital Inputs

The DAC is designed to accept CMOS inputs. The switching voltage is approximately 1/2 of the digital power supply voltage, so reducing the power supply can make the DAC compatible to smaller levels. The digital inputs (data and clock) cannot go +0.3V higher than the digital supply voltage, else diode ESD protection can begin to turn on and performance could be degraded. The clock source can be a sine wave, with some degradation in performance. The recommended clock is a square wave.

The timing between the clock and the data will affect spectral performance and functionality. Minimum setup and hold times are specified in the datasheet to represent the point at which the DAC begins to lose bits. Optimal setup and hold times vary with the clock rate to output frequency ratio. A general rule is

that the lower the F_{CLK}/F_{OUT} ratio is, the higher the setup time should be to achieve optimum spectral behavior.

Getting Started

A summary of the external supplies, equipment, and signal sources needed to operate the board is given below:

1. +5V to +3V supply for HI5x60 DAC.
2. Pattern Generator.
3. Square wave clock source (usually part of the Pattern Generator).
4. Spectrum Analyzer or Oscilloscope for viewing the output of the converter.

Attach the evaluation board to the power supply(s). Connect the bits from the data generator to the evaluation board, preferably by using a male, 64 or 96-pin VME (Versa Module Eurocard) connector that mates with the evaluation board. Connect the clock source to the evaluation board, also preferably through the VME connector. Failure to make clean and short connections to the data input lines and clock source will result in a decrease in spectral performance.

Using a coaxial cable with the proper SMA connector, attach the output of the converter, I_{OUT} , to the measurement equipment that will be evaluating the converter's performance. Make sure that the jumpers are in their proper placement. Consult the 'Voltage Reference' section and the 'Sleep' section of this document for a definition of the jumpers' functionality.

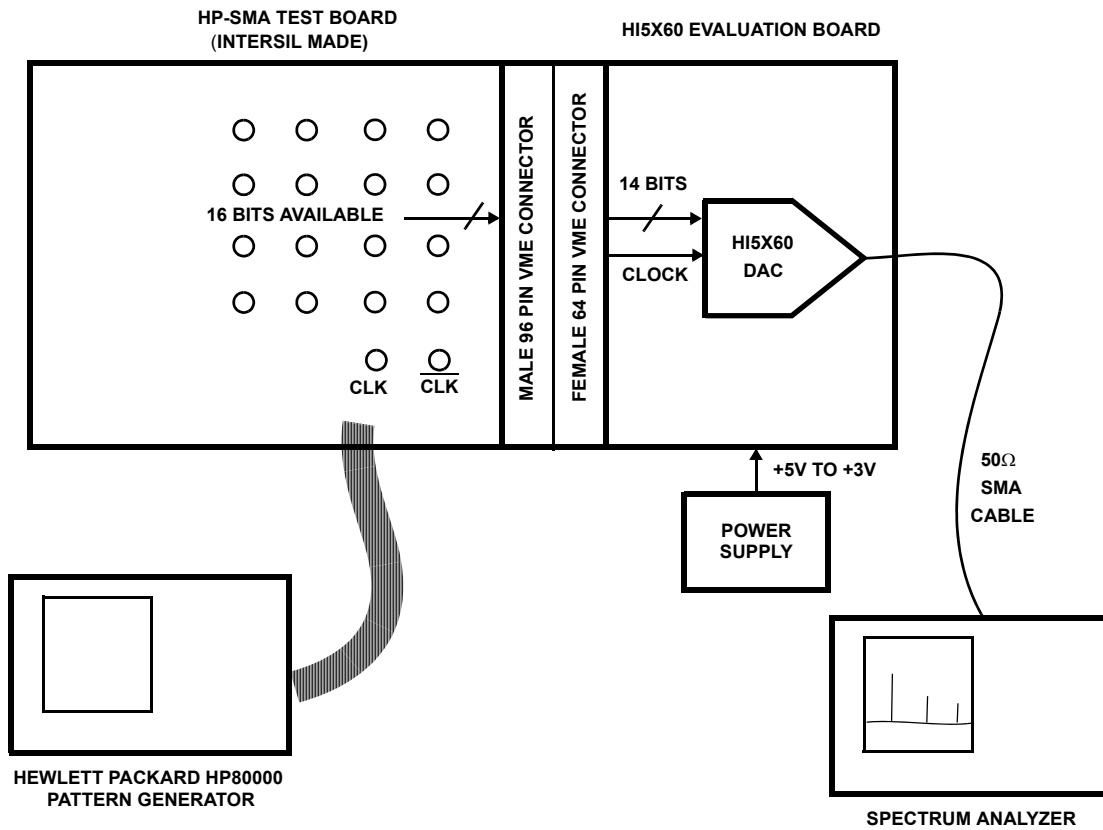

FIGURE 2. INTERASIL HI5x60 EVALUATION SYSTEM SETUP BLOCK DIAGRAM

Appendix A Description of Architecture

The segmented current source architecture has the ability to improve the converter's performance by reducing the amount of current that is switching at any one time. In traditional architectures, major transition points required the converter to switch on or off large amounts of current. In a traditional 10-bit R/2R ladder design, for example, the midscale transition required approximately equal amounts of currents switching on and off. In a segmented current source arrangement, transitions such as midscale become one in which you simply have an additional intermediate current source turning on and several minor ones turning off. In the case of the HI5760, there are 31 intermediate current segments that represent the 5 MSBs and five, binary-weighted current sources representing

each of the five LSBs. See the Functional Block Diagram in the datasheet for a visual representation. To relate the midscale transition example to the HI5760, consider the following: The code 0111111111 would be represented by 15 intermediate current segments and each of the 5 LSB current sources all turned on. To transition to code 1000000000 would simply require turning off the 5 LSB current sources and turning on the next intermediate current segment, bringing the total amount of current switching at this 'major' code transition equal to the same amount switching at 30 other code transition points in the code ramp from 0 to 1023, so that the total glitch energy is distributed more evenly.

Appendix B Pin Descriptions

PIN NO.	PIN NAME	PIN DESCRIPTION
1-14	D13 (MSB) Through D0 (LSB)	For the 14-bit, HI5960, these are digital data bit-13 (most significant bit), through digital data bit-0 (least significant bit). Pins 13 and 14 are NC for the 12-bit, HI5860.
15	SLEEP	Control Pin for Power-Down Mode. Sleep mode is active high; Connect to ground for normal mode. Sleep pin has internal 20 μ A active pull-down current.
16	REFLO	Connect to analog ground to enable internal 1.2V reference or connect to AV _{DD} to disable internal reference.
17	REFIO	Reference voltage input if internal reference is disabled. Reference voltage output if internal reference is enabled. Use 0.1 μ F cap to ground unless overdriving with a waveform.
18	FSADJ	Full Scale Current Adjust. Use a resistor to ground to adjust full scale output current. Full scale output current (I_{OUTFS}) = $32 \times V_{FSADJ}/R_{SET}$ (maximum I_{OUTFS} = 20mA).
19	COMP1	For use in reducing noise. Recommended: Connect 0.1 μ F from COMP1 to AV _{DD} .
20, 25	ACOM	Analog Ground.
21	IOUTB	The complementary current output of the device. Full scale output current is achieved when all input bits are set to binary 0.
22	IOUTA	Current output of the device. Full scale output current is achieved when all input bits are set to binary 1.
23	COMP2	Connect to ACOM through a 0.1 μ F capacitor.
24	AV _{DD}	Analog supply (+3V to +5V).
26	DCOM	Digital ground.
27	DV _{DD}	Digital supply (+3V to +5V).
28	CLK	Input for clock. Positive edge of clock latches data.

Appendix C Circuit Board Layout

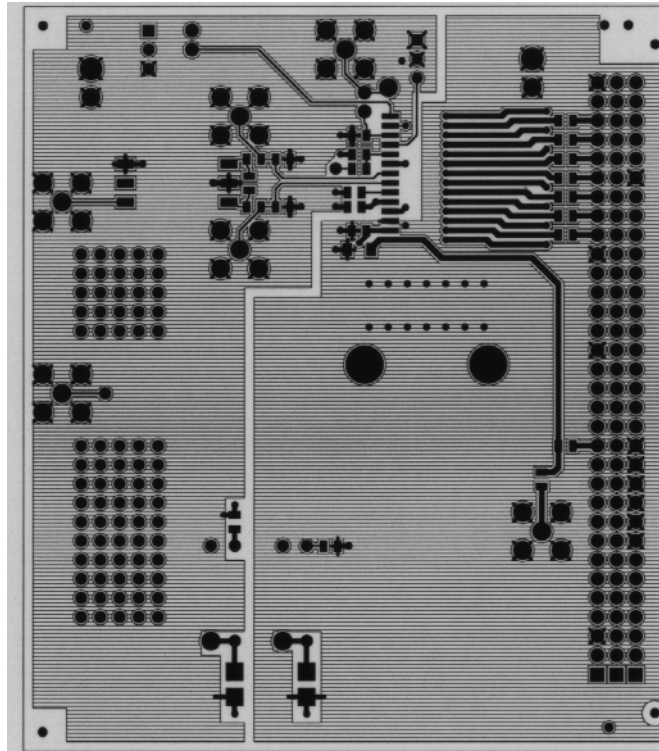

FIGURE 3. BOTTOM (LAYER 4, VIEWED FROM BOTTOM)

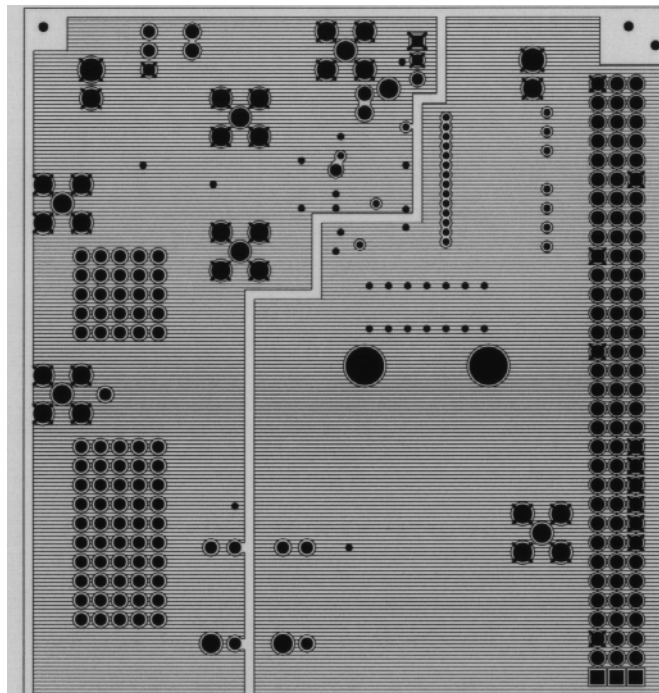

FIGURE 4. GROUND (LAYER 3, VIEWED FROM BOTTOM)

Appendix C Circuit Board Layout (Continued)

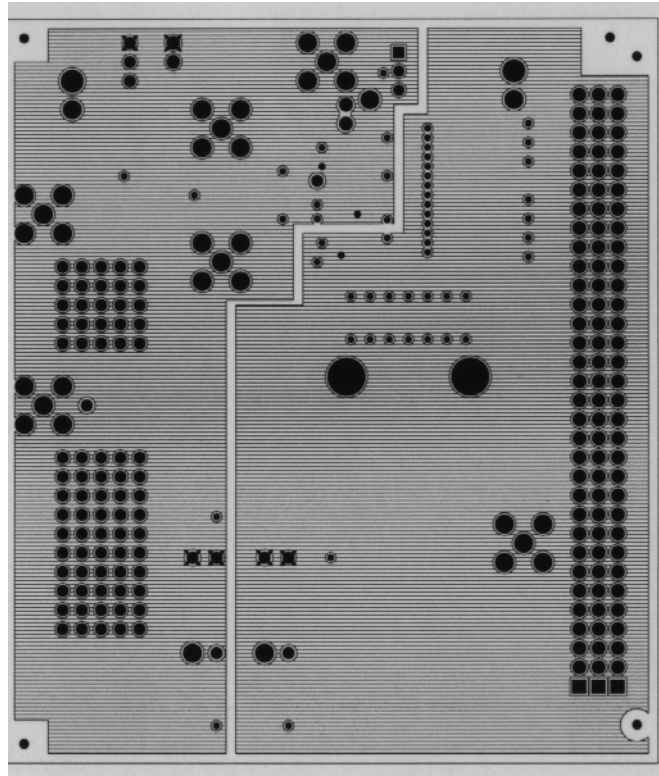

FIGURE 5. POWER (LAYER 2, VIEWED FROM BOTTOM)

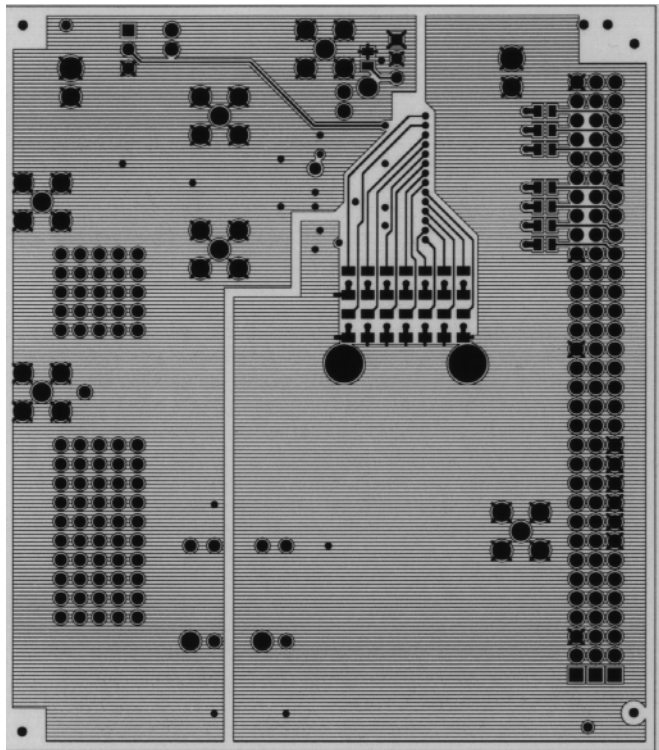
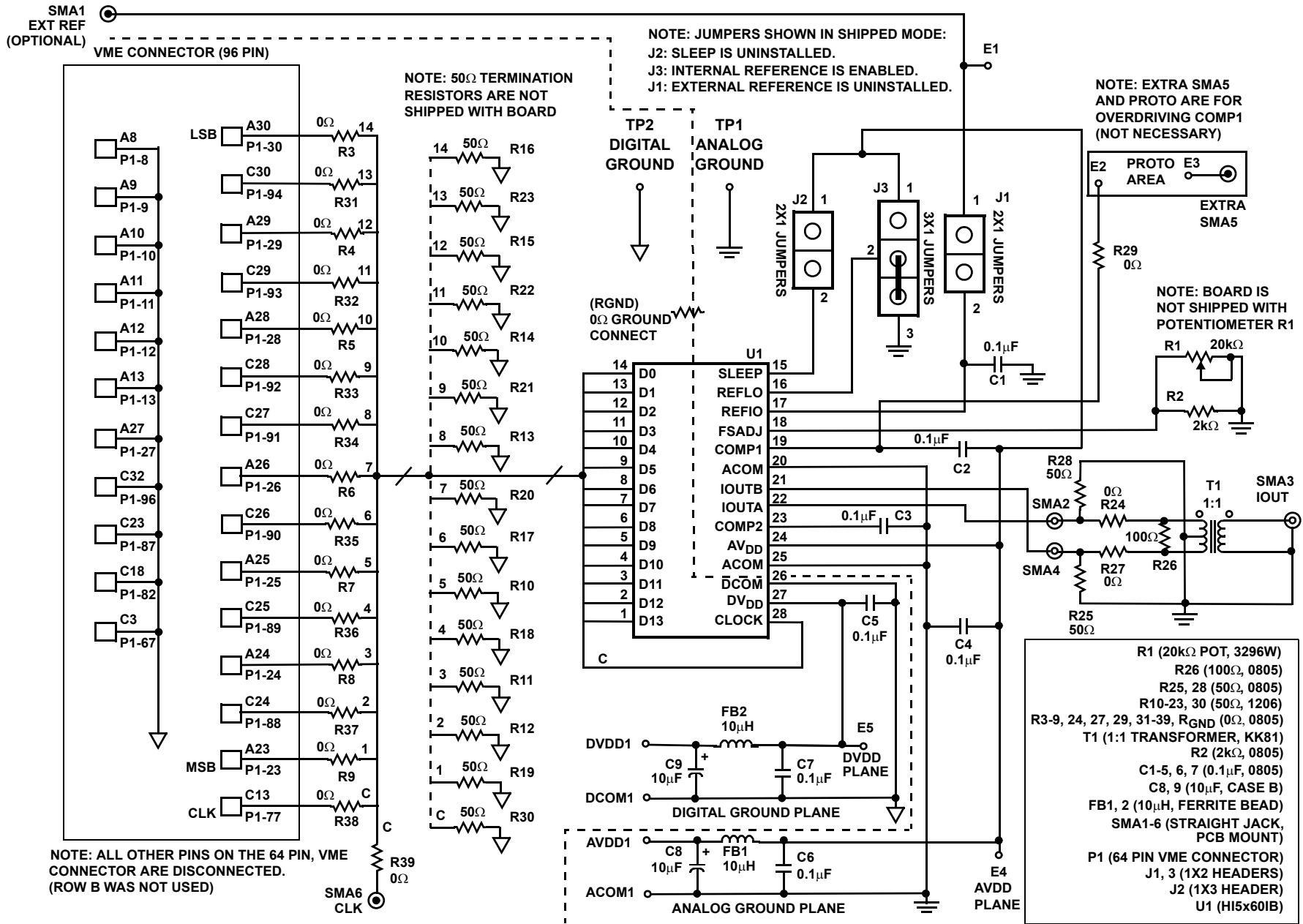

FIGURE 6. TOP SIDE (LAYER 1, VIEWED FROM BOTTOM)

Appendix D Schematic



Notice

1. Descriptions of circuits, software and other related information in this document are provided only to illustrate the operation of semiconductor products and application examples. You are fully responsible for the incorporation or any other use of the circuits, software, and information in the design of your product or system. Renesas Electronics disclaims any and all liability for any losses and damages incurred by you or third parties arising from the use of these circuits, software, or information.
2. Renesas Electronics hereby expressly disclaims any warranties against and liability for infringement or any other claims involving patents, copyrights, or other intellectual property rights of third parties, by or arising from the use of Renesas Electronics products or technical information described in this document, including but not limited to, the product data, drawings, charts, programs, algorithms, and application examples.
3. No license, express, implied or otherwise, is granted hereby under any patents, copyrights or other intellectual property rights of Renesas Electronics or others.
4. You shall not alter, modify, copy, or reverse engineer any Renesas Electronics product, whether in whole or in part. Renesas Electronics disclaims any and all liability for any losses or damages incurred by you or third parties arising from such alteration, modification, copying or reverse engineering.
5. Renesas Electronics products are classified according to the following two quality grades: "Standard" and "High Quality". The intended applications for each Renesas Electronics product depends on the product's quality grade, as indicated below.
"Standard": Computers; office equipment; communications equipment; test and measurement equipment; audio and visual equipment; home electronic appliances; machine tools; personal electronic equipment; industrial robots; etc.
"High Quality": Transportation equipment (automobiles, trains, ships, etc.); traffic control (traffic lights); large-scale communication equipment; key financial terminal systems; safety control equipment; etc.
Unless expressly designated as a high reliability product or a product for harsh environments in a Renesas Electronics data sheet or other Renesas Electronics document, Renesas Electronics products are not intended or authorized for use in products or systems that may pose a direct threat to human life or bodily injury (artificial life support devices or systems; surgical implantations; etc.), or may cause serious property damage (space system; undersea repeaters; nuclear power control systems; aircraft control systems; key plant systems; military equipment; etc.). Renesas Electronics disclaims any and all liability for any damages or losses incurred by you or any third parties arising from the use of any Renesas Electronics product that is inconsistent with any Renesas Electronics data sheet, user's manual or other Renesas Electronics document.
6. When using Renesas Electronics products, refer to the latest product information (data sheets, user's manuals, application notes, "General Notes for Handling and Using Semiconductor Devices" in the reliability handbook, etc.), and ensure that usage conditions are within the ranges specified by Renesas Electronics with respect to maximum ratings, operating power supply voltage range, heat dissipation characteristics, installation, etc. Renesas Electronics disclaims any and all liability for any malfunctions, failure or accident arising out of the use of Renesas Electronics products outside of such specified ranges.
7. Although Renesas Electronics endeavors to improve the quality and reliability of Renesas Electronics products, semiconductor products have specific characteristics, such as the occurrence of failure at a certain rate and malfunctions under certain use conditions. Unless designated as a high reliability product or a product for harsh environments in a Renesas Electronics data sheet or other Renesas Electronics document, Renesas Electronics products are not subject to radiation resistance design. You are responsible for implementing safety measures to guard against the possibility of bodily injury, injury or damage caused by fire, and/or danger to the public in the event of a failure or malfunction of Renesas Electronics products, such as safety design for hardware and software, including but not limited to redundancy, fire control and malfunction prevention, appropriate treatment for aging degradation or any other appropriate measures. Because the evaluation of microcomputer software alone is very difficult and impractical, you are responsible for evaluating the safety of the final products or systems manufactured by you.
8. Please contact a Renesas Electronics sales office for details as to environmental matters such as the environmental compatibility of each Renesas Electronics product. You are responsible for carefully and sufficiently investigating applicable laws and regulations that regulate the inclusion or use of controlled substances, including without limitation, the EU RoHS Directive, and using Renesas Electronics products in compliance with all these applicable laws and regulations. Renesas Electronics disclaims any and all liability for damages or losses occurring as a result of your noncompliance with applicable laws and regulations.
9. Renesas Electronics products and technologies shall not be used for or incorporated into any products or systems whose manufacture, use, or sale is prohibited under any applicable domestic or foreign laws or regulations. You shall comply with any applicable export control laws and regulations promulgated and administered by the governments of any countries asserting jurisdiction over the parties or transactions.
10. It is the responsibility of the buyer or distributor of Renesas Electronics products, or any other party who distributes, disposes of, or otherwise sells or transfers the product to a third party, to notify such third party in advance of the contents and conditions set forth in this document.
11. This document shall not be reprinted, reproduced or duplicated in any form, in whole or in part, without prior written consent of Renesas Electronics.
12. Please contact a Renesas Electronics sales office if you have any questions regarding the information contained in this document or Renesas Electronics products.
(Note 1) "Renesas Electronics" as used in this document means Renesas Electronics Corporation and also includes its directly or indirectly controlled subsidiaries.
(Note 2) "Renesas Electronics product(s)" means any product developed or manufactured by or for Renesas Electronics.

(Rev.4.0-1 November 2017)



SALES OFFICES

Renesas Electronics Corporation

<http://www.renesas.com>

Refer to "<http://www.renesas.com/>" for the latest and detailed information.

Renesas Electronics America Inc.
1001 Murphy Ranch Road, Milpitas, CA 95035, U.S.A.
Tel: +1-408-432-8888, Fax: +1-408-434-5351

Renesas Electronics Canada Limited
9251 Yonge Street, Suite 8309 Richmond Hill, Ontario Canada L4C 9T3
Tel: +1-905-237-2004

Renesas Electronics Europe Limited
Dukes Meadow, Millboard Road, Bourne End, Buckinghamshire, SL8 5FH, U.K.
Tel: +44-1628-651-700, Fax: +44-1628-651-804

Renesas Electronics Europe GmbH
Arcadiastrasse 10, 40472 Düsseldorf, Germany
Tel: +49-211-6503-0, Fax: +49-211-6503-1327

Renesas Electronics (China) Co., Ltd.
Room 1709 Quantum Plaza, No.27 ZhichunLu, Haidian District, Beijing, 100191 P. R. China
Tel: +86-10-8235-1155, Fax: +86-10-8235-7679

Renesas Electronics (Shanghai) Co., Ltd.
Unit 301, Tower A, Central Towers, 555 Langao Road, Putuo District, Shanghai, 200333 P. R. China
Tel: +86-21-2226-0888, Fax: +86-21-2226-0999

Renesas Electronics Hong Kong Limited
Unit 1601-1611, 16/F., Tower 2, Grand Century Place, 193 Prince Edward Road West, Mongkok, Kowloon, Hong Kong
Tel: +852-2265-6688, Fax: +852-2886-9022

Renesas Electronics Taiwan Co., Ltd.
13F, No. 363, Fu Shing North Road, Taipei 10543, Taiwan
Tel: +886-2-8175-9600, Fax: +886-2-8175-9670

Renesas Electronics Singapore Pte. Ltd.
80 Bendemeer Road, Unit #06-02 Hyflux Innovation Centre, Singapore 339949
Tel: +65-6213-0200, Fax: +65-6213-0300

Renesas Electronics Malaysia Sdn.Bhd.
Unit 1207, Block B, Menara Amcorp, Amcorp Trade Centre, No. 18, Jln Persiaran Barat, 46050 Petaling Jaya, Selangor Darul Ehsan, Malaysia
Tel: +60-3-7955-9390, Fax: +60-3-7955-9510

Renesas Electronics India Pvt. Ltd.
No.777C, 100 Feet Road, HAL 2nd Stage, Indiranagar, Bangalore 560 038, India
Tel: +91-80-67208700, Fax: +91-80-67208777

Renesas Electronics Korea Co., Ltd.
17F, KAMCO Yangjae Tower, 262, Gangnam-daero, Gangnam-gu, Seoul, 06265 Korea
Tel: +82-2-558-3737, Fax: +82-2-558-5338

Компания «Океан Электроники» предлагает заключение долгосрочных отношений при поставках импортных электронных компонентов на взаимовыгодных условиях!

Наши преимущества:

- Поставка оригинальных импортных электронных компонентов напрямую с производств Америки, Европы и Азии, а так же с крупнейших складов мира;
- Широкая линейка поставок активных и пассивных импортных электронных компонентов (более 30 млн. наименований);
- Поставка сложных, дефицитных, либо снятых с производства позиций;
- Оперативные сроки поставки под заказ (от 5 рабочих дней);
- Экспресс доставка в любую точку России;
- Помощь Конструкторского Отдела и консультации квалифицированных инженеров;
- Техническая поддержка проекта, помощь в подборе аналогов, поставка прототипов;
- Поставка электронных компонентов под контролем ВП;
- Система менеджмента качества сертифицирована по Международному стандарту ISO 9001;
- При необходимости вся продукция военного и аэрокосмического назначения проходит испытания и сертификацию в лаборатории (по согласованию с заказчиком);
- Поставка специализированных компонентов военного и аэрокосмического уровня качества (Xilinx, Altera, Analog Devices, Intersil, Interpoint, Microsemi, Actel, Aeroflex, Peregrine, VPT, Syfer, Eurofarad, Texas Instruments, MS Kennedy, Miteq, Cobham, E2V, MA-COM, Hittite, Mini-Circuits, General Dynamics и др.);

Компания «Океан Электроники» является официальным дистрибьютором и эксклюзивным представителем в России одного из крупнейших производителей разъемов военного и аэрокосмического назначения «JONHON», а так же официальным дистрибьютором и эксклюзивным представителем в России производителя высокотехнологичных и надежных решений для передачи СВЧ сигналов «FORSTAR».



JONHON

«JONHON» (основан в 1970 г.)

Разъемы специального, военного и аэрокосмического назначения:

(Применяются в военной, авиационной, аэрокосмической, морской, железнодорожной, горно- и нефтедобывающей отраслях промышленности)

«FORSTAR» (основан в 1998 г.)

ВЧ соединители, коаксиальные кабели, кабельные сборки и микроволновые компоненты:

(Применяются в телекоммуникациях гражданского и специального назначения, в средствах связи, РЛС, а так же военной, авиационной и аэрокосмической отраслях промышленности).



Телефон: 8 (812) 309-75-97 (многоканальный)

Факс: 8 (812) 320-03-32

Электронная почта: ocean@oceanchips.ru

Web: <http://oceanchips.ru/>

Адрес: 198099, г. Санкт-Петербург, ул. Калинина, д. 2, корп. 4, лит. А