

## MAX7322

## I<sup>2</sup>C Port Expander with 4 Push-Pull Outputs and 4 Inputs

### General Description

The MAX7322 2-wire serial-interfaced peripheral features four push-pull outputs and four input ports with selectable internal pullups. Input ports are overvoltage protected to +6V and feature transition detection with interrupt output.

The four input ports are continuously monitored for state changes (transition detection). The interrupt is latched, allowing detection of transient changes. Any combination of inputs can be selected using the interrupt mask to assert the open-drain  $\overline{\text{INT}}$  output. When the MAX7322 is subsequently accessed through the serial interface, any pending interrupt is cleared.

The four push-pull outputs are rated to sink 20mA, and are capable of driving LEDs.

The  $\overline{\text{RST}}$  input clears the serial interface, terminating any I<sup>2</sup>C communication to or from the MAX7322.

The MAX7322 uses two address inputs with four-level logic to allow 16 I<sup>2</sup>C slave addresses. The slave address also sets the power-up default logic state for the four output ports, and enables or disables internal 40k $\Omega$  pullups for the input ports.

The MAX7322 is one device in a family of pin-compatible port expanders with a choice of input ports, open-drain I/O ports, and push-pull output ports (see Table 1).

The MAX7322 is available in 16-pin QSOP and TQFN packages, and is specified over the -40°C to +125°C automotive temperature range.

### Applications

- Cell Phones
- SAN/NAS
- Servers
- Notebooks
- Satellite Radio

### Pin Configurations

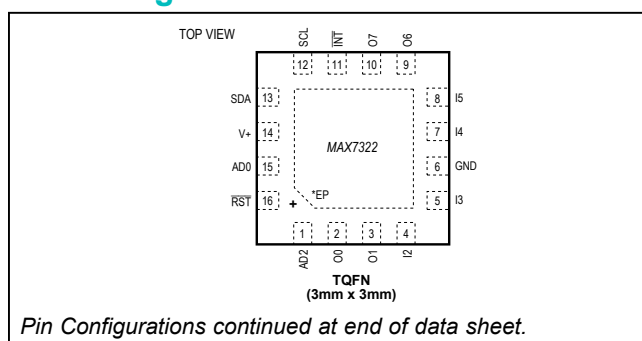

### Features

- 400kHz I<sup>2</sup>C Serial Interface
- +1.71V to +5.5V Operation Voltage
- 4 Push-Pull Output Ports Rated at 20mA Sink Current
- 4 Input Ports with Maskable, Latching Transition Detection
- Input Ports are Overvoltage Protected to +6V
- Transient Changes are Latched, Allowing Detection Between Read Operations
- $\overline{\text{INT}}$  Output Alerts Change on Any Selection of Inputs
- AD0 and AD2 Inputs Select from 16 Slave Addresses
- Low 0.6 $\mu$ A (typ) Standby Current
- -40°C to +125°C Operating Temperature Range

### Ordering Information

PART	TEMP RANGE	PIN-PACKAGE	TOP MARK
MAX7322AEE+	-40°C to +125°C	16 QSOP	—
MAX7322ATE+	-40°C to +125°C	16 TQFN-EP* (3mm x 3mm)	ADD

+Denotes a lead(Pb)-free/RoHS-compliant package.

\*EP = Exposed pad.

### Selector Guide

PART	INPUTS	INTERRUPT MASK	OPEN-DRAIN OUTPUTS	PUSH-PULL OUTPUTS
MAX7319	8	Yes	—	—
MAX7320	—	—	—	8
MAX7321	Up to 8	—	Up to 8	—
MAX7322	4	Yes	—	4
MAX7323	Up to 4	—	Up to 4	4
MAX7328	Up to 8	—	Up to 8	—
MAX7329	Up to 8	—	Up to 8	—

Typical Application Circuit and Functional Diagram appear at end of data sheet.

**Absolute Maximum Ratings**

(All voltages referenced to GND.)

Supply Voltage V+ .....	-0.3V to +6V	Total GND Current .....	100mA
SCL, SDA, AD0, AD2, $\overline{RST}$ , $\overline{INT}$ , I2-I5 .....	-0.3V to +6V	Continuous Power Dissipation (T <sub>A</sub> = +70°C)	
O0, O1, O6, O7 .....	-0.3 to V+ + 0.3V	QSOP (derate 8.3mW/°C above +70°C) .....	667mW
O0, O1, O6, O7 Output Current .....	±25mA	TQFN (derate 15.6mW/°C above +70°C) .....	1250mW
SDA Sink Current .....	10mA	Operating Temperature Range .....	-40°C to +125°C
$\overline{INT}$ Sink Current .....	10mA	Junction Temperature .....	+150°C
Total V+ Current .....	50mA	Storage Temperature Range .....	-65°C to +150°C
		Lead Temperature (soldering, 10s) .....	+300°C

Stresses beyond those listed under "Absolute Maximum Ratings" may cause permanent damage to the device. These are stress ratings only, and functional operation of the device at these or any other conditions beyond those indicated in the operational sections of the specifications is not implied. Exposure to absolute maximum rating conditions for extended periods may affect device reliability.

**DC Electrical Characteristics**

(V+ = +1.71V to +5.5V, T<sub>A</sub> = -40°C to +125°C, unless otherwise noted. Typical values are at V+ = +3.3V, T<sub>A</sub> = +25°C.) (Note 1)

PARAMETER	SYMBOL	CONDITIONS	MIN	TYP	MAX	UNITS
Operating Supply Voltage	V+		1.71		5.50	V
Power-On Reset Voltage	VPOR	V+ falling			1.6	V
Standby Current (Interface Idle)	ISTB	SCL and SDA and other digital inputs at V+		0.6	1.5	µA
Supply Current (Interface Running)	I+	fSCL = 400kHz; other digital inputs at V+		23	55	µA
Input High Voltage SDA, SCL, AD0, AD2, $\overline{RST}$ , I2-I5	V <sub>IH</sub>	V+ < 1.8V	0.8 x V+			V
		V+ ≥ 1.8V	0.7 x V+			
Input Low Voltage SDA, SCL, AD0, AD2, $\overline{RST}$ , I2-I5	V <sub>IL</sub>	V+ < 1.8V			0.2 x V+	V
		V+ ≥ 1.8V			0.3 x V+	
Input Leakage Current SDA, SCL, AD0, AD2, $\overline{RST}$ , I2-I5	I <sub>IH</sub> , I <sub>IL</sub>	SDA, SCL, AD0, AD2, $\overline{RST}$ , at V+ or GND, internal pullup disabled	-0.2		+0.2	µA
Input Capacitance SDA, SCL, AD0, AD2, $\overline{RST}$ , I2-I5				10		pF
Output Low Voltage O0, O1, O6, O7	V <sub>OL</sub>	V+ = +1.71V, I <sub>SINK</sub> = 5mA		90	180	mV
		V+ = +2.5V, I <sub>SINK</sub> = 10mA		110	210	
		V+ = +3.3V, I <sub>SINK</sub> = 15mA		130	230	
		V+ = +5V, I <sub>SINK</sub> = 20mA		140	250	
Output High Voltage O0, O1, O6, O7	V <sub>OH</sub>	V+ = +1.71V, I <sub>SOURCE</sub> = 2mA	V+ - 250	V+ - 30		mV
		V+ = +2.5V, I <sub>SOURCE</sub> = 5mA	V+ - 360	V+ - 70		
		V+ = +3.3V, I <sub>SOURCE</sub> = 5mA	V+ - 260	V+ - 100		
		V+ = +5V, I <sub>SOURCE</sub> = 10mA	V+ - 360	V+ - 120		
Output Low Voltage SDA	V <sub>OLSDA</sub>	I <sub>SINK</sub> = 6mA			250	mV
Output Low Voltage $\overline{INT}$	V <sub>OLINT</sub>	I <sub>SINK</sub> = 5mA		130	250	mV
Port Input Pullup Resistor	R <sub>PU</sub>		25	40	55	kΩ

## Port and Interrupt $\overline{\text{INT}}$ Timing Characteristics

(V+ = +1.71V to +5.5V, T<sub>A</sub> = -40°C to +125°C, unless otherwise noted. Typical values are at V+ = +3.3V, T<sub>A</sub> = +25°C.) (Note 1)

PARAMETER	SYMBOL	CONDITIONS	MIN	TYP	MAX	UNITS
Port Output Data Valid	t <sub>PPV</sub>	CL ≤ 100pF			4	μs
Port Input Setup Time	t <sub>PSU</sub>	CL ≤ 100pF	0			μs
Port Input Hold Time	t <sub>PH</sub>	CL ≤ 100pF	4			μs
$\overline{\text{INT}}$ Input Data Valid Time	t <sub>IV</sub>	CL ≤ 100pF			4	μs
$\overline{\text{INT}}$ Reset Delay Time from STOP	t <sub>IP</sub>	CL ≤ 100pF			4	μs
$\overline{\text{INT}}$ Reset Delay Time from Acknowledge	t <sub>IR</sub>	CL ≤ 100pF			4	μs

## Timing Characteristics

(V+ = +1.71V to +5.5V, T<sub>A</sub> = -40°C to +125°C, unless otherwise noted. Typical values are at V+ = +3.3V, T<sub>A</sub> = +25°C.) (Note 1)

PARAMETER	SYMBOL	CONDITIONS	MIN	TYP	MAX	UNITS
Serial-Clock Frequency	f <sub>SCL</sub>				400	kHz
Bus Free Time Between a STOP and a START Condition	t <sub>BUF</sub>		1.3			μs
Hold Time (Repeated) START Condition	t <sub>HD, STA</sub>		0.6			μs
Repeated START Condition Setup Time	t <sub>SU, STA</sub>		0.6			μs
STOP Condition Setup Time	t <sub>SU, STO</sub>		0.6			μs
Data Hold Time	t <sub>HD, DAT</sub>	(Note 2)			0.9	μs
Data Setup Time	t <sub>SU, DAT</sub>		100			ns
SCL Clock Low Period	t <sub>LOW</sub>		1.3			μs
SCL Clock High Period	t <sub>HIGH</sub>		0.7			μs
Rise Time of Both SDA and SCL Signals, Receiving	t <sub>R</sub>	(Notes 3, 4)		20 + 0.1C <sub>b</sub>	300	ns
Fall Time of Both SDA and SCL Signals, Receiving	t <sub>F</sub>	(Notes 3, 4)		20 + 0.1C <sub>b</sub>	300	ns
Fall Time of SDA, Transmitting	t <sub>F, TX</sub>	(Notes 3, 4)		20 + 0.1C <sub>b</sub>	250	ns
Pulse Width of Spike Suppressed	t <sub>SP</sub>	(Note 5)		50		ns
Capacitive Load for Each Bus Line	C <sub>b</sub>	(Note 3)			400	pF
$\overline{\text{RST}}$ Pulse Width	t <sub>W</sub>		500			ns
$\overline{\text{RST}}$ Rising to START Condition Setup Time	t <sub>R<math>\overline{\text{RST}}</math></sub>		1			μs

**Note 1:** All parameters are tested at T<sub>A</sub> = +25°C. Specifications over temperature are guaranteed by design.

**Note 2:** A master device must provide a hold time of at least 300ns for the SDA signal (referred to V<sub>IL</sub> of the SCL signal) in order to bridge the undefined region of SCL's falling edge.

**Note 3:** Guaranteed by design.

**Note 4:** C<sub>b</sub> = total capacitance of one bus line in pF. t<sub>R</sub> and t<sub>F</sub> measured between 0.3 x V+ and 0.7 x V+ with I<sub>SINK</sub> ≤ 6mA.

**Note 5:** Input filters on the SDA and SCL inputs suppress noise spikes less than 50ns.

Typical Operating Characteristics

(T<sub>A</sub> = +25°C, unless otherwise noted.)

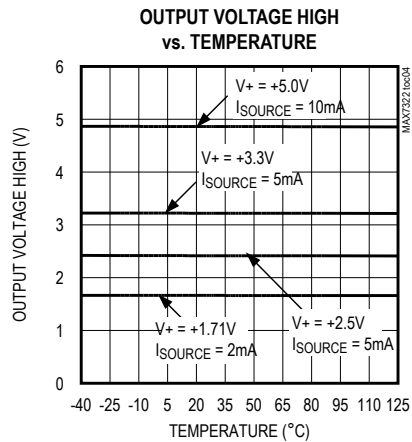
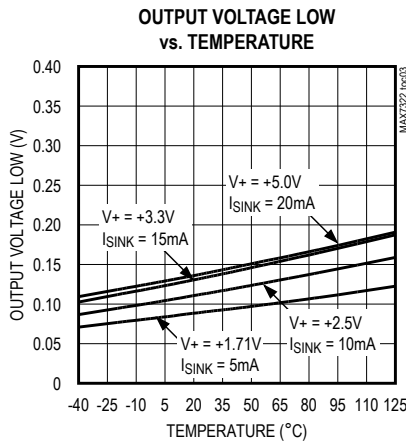
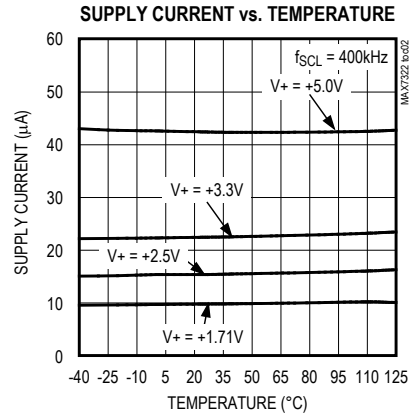
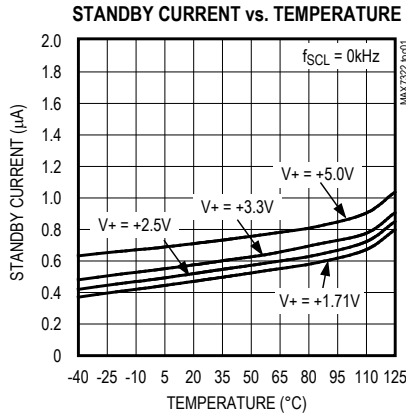

Pin Description

PIN		NAME	FUNCTION
QSOP	TQFN		
1, 3	15, 1	AD0, AD2	Address Inputs. Select device slave address with AD0 and AD2. Connect AD0 and AD2 to either GND, V+, SCL, or SDA to give four logic combinations (see Table 2).
2	16	RST	Reset Input. Active Low. Drive RST low to clear the 2-wire interface.
4, 5, 11, 12,	2, 3, 9, 10	O0, O1, O6, O7	Push-Pull Output Ports
6, 7, 9, 10	4, 5, 7, 8	I2–I5	Input Ports. I2 to I5 are CMOS-logic inputs protected to +6V.
8	6	GND	Ground
13	11	INT	Interrupt Output, Active Low. INT is an open-drain output.
14	12	SCL	I <sup>2</sup> C-Compatible Serial-Clock Input
15	13	SDA	I <sup>2</sup> C-Compatible Serial-Data I/O
16	14	V+	Positive Supply Voltage. Bypass V+ to GND with a ceramic capacitor of at least 0.047µF.
—	EP	EP	Exposed Pad. Connect exposed pad to GND.

**Detailed Description**

**MAX7319–MAX7329 Family Comparison**

The MAX7319–MAX7323 family consists of five pin-compatible, eight-port expanders. Each version is optimized for different applications. The MAX7328 and MAX7329 are industry-standard parts.

The MAX7324–MAX7327 family consists of four pin-compatible, 16-port expanders that integrate the functions of the MAX7320 and one of either MAX7319, MAX7321, MAX7322, or MAX7323.

**Functional Overview**

The MAX7322 is a general-purpose port expander operating from +1.71V to +5.5V supply that provides four push-pull output ports with 20mA sink, 10mA source drive capability, and four input ports that are overvoltage protected to +6V independent of supply voltage. The MAX7322 is rated to sink a total of 100mA and source a total of 50mA from all four combined outputs.

The MAX7322 is set to one of 16 I<sup>2</sup>C slave addresses (0x60 to 0x6F) using address inputs AD2 and AD0, and is accessed over an I<sup>2</sup>C serial interface up to 400kHz. The  $\overline{RST}$  input clears the serial interface in case of a bus lockup, terminating any serial transaction to or from the MAX7322.

**Table 1. MAX7319–MAX7329 Family Comparison**

PART	I <sup>2</sup> C SLAVE ADDRESS	INPUTS	INPUT INTERRUPT MASK	OPEN-DRAIN OUTPUTS	PUSH-PULL OUTPUTS	I <sup>2</sup> C DATA WRITE	I <sup>2</sup> C DATA READ	APPLICATION
<b>8-PORT EXPANDERS</b>								
MAX7319	110xxxx	8	Yes	—	—	<17–10 Interrupt mask>	<17–10 port inputs> <17–10 Transition flags>	Input-only versions: 8 input ports with programmable latching transition detection interrupt and selectable pullups. Offers maximum versatility for automatic input monitoring. An interrupt mask selects which inputs cause an interrupt on transitions, and transition flags identify which inputs have changed (even momentarily) since the ports were last read.
MAX7320	101xxxx	—	—	—	8	<07–00 Port outputs>	<07–00 port inputs>	Output-only versions: 8 push-pull outputs with selectable power-up default levels. Push-pull outputs offer faster rise time than open-drain outputs, and require no pullup resistors.

Table 1. MAX7319–MAX7329 Family Comparison (continued)

PART	I <sup>2</sup> C SLAVE ADDRESS	INPUTS	INPUT INTERRUPT MASK	OPEN-DRAIN OUTPUTS	PUSH-PULL OUTPUTS	I <sup>2</sup> C DATA WRITE	I <sup>2</sup> C DATA READ	APPLICATION
MAX7321	110xxxx	Up to 8	—	Up to 8	—	<P7–P0 Port outputs>	<P7–P0 port inputs> <P7–P0 Transition flags>	I/O versions: 8 open-drain I/O ports with latching transition detection interrupt and selectable pullups.  Open-drain outputs can level shift the logic-high state to a higher or lower voltage than V+ using external pullup resistors. Any port can be used as an input by setting the open-drain output to logic-high. Transition flags identify which inputs have changed (even momentarily) since the ports were last read.
MAX7322	110xxxx	4	Yes	—	4	<O7, O6 outputs, I5–I2 Interrupt mask, O1, O0 outputs>	<O7, O6, I5–I2, O1, O0 port inputs> <O, O, I5–I2 Transition flags, O, O>	4 input-only, 4 output-only versions: 4 input ports with programmable latching transition detection interrupt and selectable pullups; 4 push-pull outputs with selectable power-up default levels.
MAX7323	110xxxx	Up to 4	—	Up to 4	4	<port outputs>	<O7, O6, P5–P2, O1, O0 port inputs> <O, O, P5–P2 Transition flags, O, O>	4 I/O, 4 output-only versions: 4 open-drain I/O ports with latching transition detection interrupt and selectable pullups. 4 push-pull outputs with selectable power-up default levels.
MAX7328 MAX7329	0100xxx 0111xxx	Up to 8	—	Up to 8	—	<P7–P0 Port outputs>	<P7–P0 port inputs>	8 open-drain I/O ports with nonlatching transition detection interrupt and pullups on all ports.  All ports power up as inputs (or logic-high outputs).  Any port can be used as an input by setting the open-drain output to logic-high.

**Table 1. MAX7319–MAX7329 Family Comparison (continued)**

PART	I <sup>2</sup> C SLAVE ADDRESS	INPUTS	INPUT INTERRUPT MASK	OPEN-DRAIN OUTPUTS	PUSH-PULL OUTPUTS	I <sup>2</sup> C DATA WRITE	I <sup>2</sup> C DATA READ	APPLICATION
<b>16-PORT EXPANDERS</b>								
MAX7324	101xxxx And 110xxxx	8	Yes	—	8	—	—	Software equivalent to a MAX7320 plus a MAX7319.
MAX7325		Up to 8	—	Up to 8	8	—	—	Software equivalent to a MAX7320 plus a MAX7321.
MAX7326		4	Yes	—	12	—	—	Software equivalent to a MAX7320 plus a MAX7322.
MAX7327		Up to 4	—	Up to 4	12	—	—	Software equivalent to a MAX7320 plus a MAX7323.

When the MAX7322 is read through the serial interface the actual logic levels at the ports are read back.

The four input ports offer latching transition detection functionality. All input ports are continuously monitored for changes. An input change sets 1 of 4 flag bits that identify the changed input(s). All flags are cleared upon a subsequent read or write transaction to the MAX7322.

A latching interrupt output,  $\overline{INT}$ , is programmed to flag input data changes on the four input ports through an interrupt mask register. By default, data changes on any input port force  $\overline{INT}$  to a logic low. The interrupt output  $\overline{INT}$  and all transition flags are deasserted when the MAX7322 is next accessed through the serial interface.

Internal pullup resistors to V+ are selected by the address select inputs, AD0 and AD2. Pullups are enabled on the input ports in groups of two (see Table 2).

Output port power-up logic states are selected by the address select inputs AD0 and AD2. Ports default to logic-high or logic-low on power-up in groups of two (see Table 2).

### Initial Power-Up

On power-up, the transition detection logic is reset, and  $\overline{INT}$  is deasserted. The interrupt mask register is set to 0x3C, enabling the interrupt output for transitions on all four input ports. The transition flags are cleared to indicate no data changes. The power-up default state of the four push-pull outputs are set according to the I<sup>2</sup>C slave address selection inputs, AD0 and AD2 (Table 2).

### Power-On Reset (POR)

The MAX7322 contains an integral POR circuit that ensures all registers are reset to a known state on

power-up. When V+ rises above V<sub>POR</sub> (1.6V max), the POR circuit releases the registers and 2-wire interface for normal operation. When V+ drops to less than V<sub>POR</sub>, the MAX7322 resets all register contents to the POR defaults (Table 2).

### $\overline{RST}$ Input

The active-low  $\overline{RST}$  input operates as a reset that voids any current I<sup>2</sup>C transaction involving the MAX7322, forcing the MAX7322 into the I<sup>2</sup>C STOP condition. The reset action does not clear the interrupt output ( $\overline{INT}$ ).

### Standby Mode

When the serial interface is idle, the MAX7322 automatically enters standby mode, drawing minimal supply current.

### Slave Address and Input Pullup Selection/Default Logic State

Address inputs AD0 and AD2 determine the MAX7322 slave address, select which inputs have pullup resistors and set the default logic state for outputs. Pullups are enabled on the input ports in groups of two (see Table 2). The MAX7319, MAX7321, MAX7322, and MAX7323 use a different range of slave addresses (110xxxx) than the MAX7320 (101xxxx).

The MAX7322 slave address is determined on each I<sup>2</sup>C transmission, regardless of whether the transmission is actually addressing the MAX7322. The MAX7322 distinguishes whether address inputs AD2 and AD0 are connected to SDA or SCL instead of fixed logic levels V+ or GND during this transmission. This means that the MAX7322 slave address can be configured dynamically in the application without cycling the device supply.



On initial power-up, the MAX7322 cannot decode the address inputs AD2 and AD0 fully until the first I<sup>2</sup>C transmission. AD0 and AD2 initially appear to be connected to V+ or GND. This is important because the address selection determines the power-up logic state, and whether pullups are enabled. However, at power-up, the I<sup>2</sup>C SDA and SCL bus interface lines are high impedance at the pins of every device (master or slave) connected to the bus, including the MAX7322. This is guaranteed as part of the I<sup>2</sup>C specification. Therefore, address inputs AD2 and AD0 that are connected to SDA or SCL normally appear at power-up to be connected to V+. The port selection logic uses AD0 to select whether pullups are enabled for ports I2 and I3, and to set the initial logic state for ports O0 and O1. AD2 selects whether pullups are enabled for ports I4 and I5 and sets the internal logic state for ports O6 and O7. The rule is that a logic-high, SDA, or SCL connection selects the pullups and sets the default logic state high. A logic-low deselects the pullups and sets the default logic state low (Table 2). This means that the port configuration is correct on power-up for a standard I<sup>2</sup>C configuration, where SDA or SCL are pulled up to V+ by the external I<sup>2</sup>C pullup resistors.

There are circumstances where the assumption that SDA = SCL = V+ on power-up is not true—for example, in applications in which there is legitimate bus activity

during power-up. Also, if SDA and SCL are terminated with pullup resistors to a different supply voltage than the MAX7322’s supply voltage, and if that pullup supply rises later than the MAX7322’s supply, then SDA or SCL may appear at power-up to be connected to GND. In such applications, use the four address combinations that are selected by connecting address inputs AD2 and AD0 to V+ or GND (shown in **bold** in Table 2). These selections are guaranteed to be correct at power-up, independent of SDA and SCL behavior. If one of the other 12 address combinations is used, an unexpected combination of pullups might be asserted until the first I<sup>2</sup>C transmission (to any device, not necessarily the MAX7322) is put on the bus, and an unexpected combination of ports may initialize as logic-low outputs instead of inputs or logic-high outputs.

**Port Inputs**

Port inputs switch at CMOS logic levels as determined by the expander’s supply voltage, and are overvoltage tolerant to +6V, independent of the expander’s supply voltage.

**Port Input Transition Detection**

All four input ports are monitored for changes since the expander was last accessed through the serial interface. The state of the I/O ports is stored in an internal “snapshot” register for transition monitoring.

**Table 2. MAX7322 Address Map**

PIN CONNECTION		DEVICE ADDRESS								OUTPUTS POWER—UP DEFAULT				40kΩ INPUT PULLUPS ENABLED											
AD2	AD0	A6	A5	A4	A3	A2	A1	A0	O7	O6	I5	I4	I3	I2	O1	O0	O7	O6	I5	I4	I3	I2	O1	O0	
SCL	GND	1	1	0	0	0	0	0	1	1	Inputs				0	0	Pullups are not enabled for push-pull outputs								
SCL	V+	1	1	0	0	0	0	1	1	1					1	1				Y	Y	—	—		
SCL	SCL	1	1	0	0	0	1	0	1	1					1	1				Y	Y	Y	Y		
SCL	SDA	1	1	0	0	0	1	1	1	1					1	1				Y	Y	Y	Y		
SDA	GND	1	1	0	0	1	0	0	1	1					0	0				Y	Y	—	—		
SDA	V+	1	1	0	0	1	0	1	1	1					1	1				Y	Y	Y	Y		
SDA	SCL	1	1	0	0	1	1	0	1	1					1	1				Y	Y	Y	Y		
SDA	SDA	1	1	0	0	1	1	1	1	1					1	1				Y	Y	Y	Y		
<b>GND</b>	<b>GND</b>	<b>1</b>	<b>1</b>	<b>0</b>	<b>1</b>	<b>0</b>	<b>0</b>	<b>0</b>	<b>0</b>	<b>0</b>					<b>0</b>	<b>0</b>				—	—	—	—		
<b>GND</b>	<b>V+</b>	<b>1</b>	<b>1</b>	<b>0</b>	<b>1</b>	<b>0</b>	<b>0</b>	<b>1</b>	<b>0</b>	<b>0</b>					<b>1</b>	<b>1</b>				—	—	<b>Y</b>	<b>Y</b>		
GND	SCL	1	1	0	1	0	1	0	0	0					1	1				—	—	Y	Y		
GND	SDA	1	1	0	1	0	1	1	0	0					1	1				—	—	Y	Y		
<b>V+</b>	<b>GND</b>	<b>1</b>	<b>1</b>	<b>0</b>	<b>1</b>	<b>1</b>	<b>0</b>	<b>0</b>	<b>1</b>	<b>1</b>					<b>0</b>	<b>0</b>				<b>Y</b>	<b>Y</b>	<b>—</b>	<b>—</b>		
<b>V+</b>	<b>V+</b>	<b>1</b>	<b>1</b>	<b>0</b>	<b>1</b>	<b>1</b>	<b>0</b>	<b>1</b>	<b>1</b>	<b>1</b>					<b>1</b>	<b>1</b>				<b>Y</b>	<b>Y</b>	<b>Y</b>	<b>Y</b>		
V+	SCL	1	1	0	1	1	1	0	1	1					1	1				Y	Y	Y	Y		
V+	SDA	1	1	0	1	1	1	1	1	1					1	1				Y	Y	Y	Y		



The snapshot is continuously compared with the actual input conditions, and if a change is detected for any port input, then an internal transition flag is set for that port, and  $\overline{INT}$  is asserted to signal a state change. The four port inputs are sampled (internally latched into the snapshot register) and the old transition flags cleared during the I<sup>2</sup>C acknowledge of every MAX7322 read and write access. The previous port transition flags are read through the serial interface as the second byte of a 2-byte read sequence.

A long read sequence (more than 2 bytes) can be used to poll the expander continuously without the overhead of resending the slave address. If more than 2 bytes are read from the expander, the expander repeatedly returns the input port data alternating with the transition flags. The inputs are repeatedly resampled and the transition flags repeatedly reset for each pair of bytes read. All changes that occur during a long read sequence are detected and reported.

The MAX7322 includes a 4-bit interrupt mask register that selects which inputs generate an interrupt upon change. Each input's transition flag is set when its input changes, independent of the interrupt mask register settings. The interrupt mask register allows the processor to be interrupted for critical events, while the inputs and the transition flags can be polled periodically to detect less-critical events.

The  $\overline{INT}$  output is not reasserted during a read sequence to avoid recursive reentry into an interrupt service routine. Instead, if a data change occurs that would normally cause the  $\overline{INT}$  output to be set, the  $\overline{INT}$  assertion is delayed until the STOP condition.  $\overline{INT}$  is not reasserted upon a STOP condition if the changed input data is read before the STOP occurs. The  $\overline{INT}$  logic ensures that unnecessary interrupts are not asserted, yet data changes are detected and reported no matter when the change occurs.

**Transition Detection Masks**

The transition detection logic incorporates a change flag and an interrupt mask bit for each of the four input ports. The four change flags can be read through the serial interface, and the 4-bit interrupt mask is set through the serial interface.

Each port's change flag is set when that port's input changes, and the change flag remains set even if the input returns to its original state. The port's interrupt mask determines whether a change on that input port generates an interrupt. Enable interrupts for high-priority inputs using the interrupt mask. The interrupt allows the system to respond quickly to changes on these inputs. Poll the MAX7322 periodically to monitor less-important inputs. The change flags indicate whether a permanent or transient change has occurred on any input since the MAX7322 was last accessed.

**Port Outputs**

Write one byte to the MAX7322 to set the output port levels for the four push-pull outputs, and the interrupt mask for the four inputs simultaneously.

**Serial Interface**

**Serial Addressing**

The MAX7322 operates as a slave that sends and receives data through an I<sup>2</sup>C interface. The interface uses a serial-data line (SDA) and a serial-clock line (SCL) to achieve bidirectional communication between master(s) and slave(s). The master initiates all data transfers to and from the MAX7322 and generates the SCL clock that synchronizes the data transfer (Figure 1).

SDA operates as both an input and an open-drain output. A pullup resistor, typically 4.7k $\Omega$ , is required on SDA. SCL operates only as an input. A pullup resistor, typically 4.7k $\Omega$ , is required on SCL if there are multiple masters

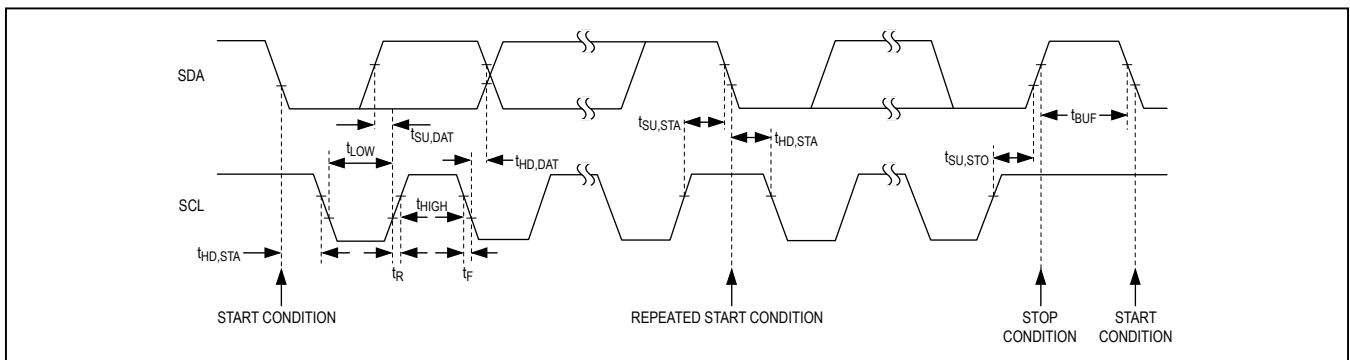

Figure 1. 2-Wire Serial Interface Timing Details

on the 2-wire interface, or if the master in a single-master system has an open-drain SCL output.

Each transmission consists of a START condition sent by a master, followed by the MAX7322's 7-bit slave address plus  $R/\overline{W}$  bit, one or more data bytes, and finally a STOP condition (Figure 2).

**Start and Stop Conditions**

Both SCL and SDA remain high when the interface is not busy. A master signals the beginning of a transmission with a START (S) condition by transitioning SDA from high to low while SCL is high. When the master has finished communicating with the slave, the master issues a STOP (P) condition by transitioning SDA from low to high while SCL is high. The bus is then free for another transmission (Figure 2).

**Bit Transfer**

One data bit is transferred during each clock pulse. The data on SDA must remain stable while SCL is high (Figure 3).

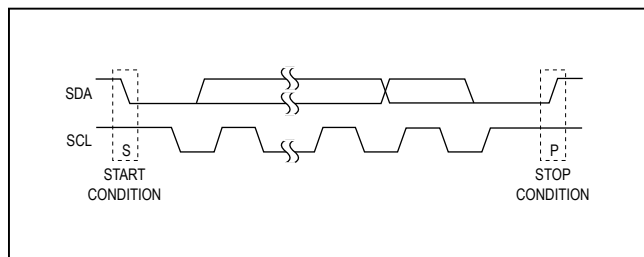

Figure 2. Start and Stop Conditions

**Acknowledge**

The acknowledge bit is a clocked 9th bit the recipient uses to acknowledge receipt of each byte of data (Figure 4). Each byte transferred effectively requires 9 bits. The master generates the 9th clock pulse, and the recipient pulls down SDA during the acknowledge clock pulse, such that the SDA line is stable low during the high period of the clock pulse. When the master is transmitting to the MAX7322, the MAX7322 generates the acknowledge bit because the device is the recipient. When the MAX7322 is transmitting to the master, the master generates the acknowledge bit because the master is the recipient.

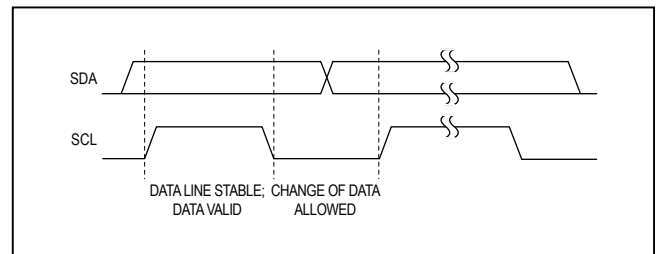

Figure 3. Bit Transfer

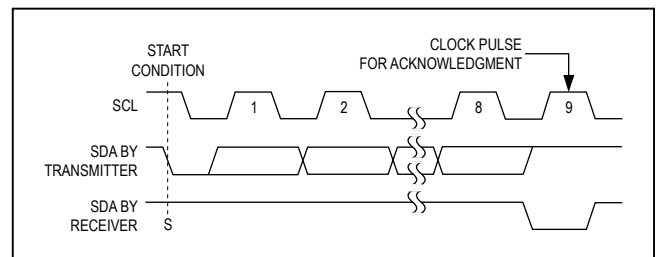

Figure 4. Acknowledge

**Slave Address**

The MAX7322 has a 7-bit-long slave address (Figure 5). The eighth bit following the 7-bit slave address is the R/W bit. It is low for a write command, and high for a read command.

The first (A6), second (A5), and third (A4) bits of the MAX7322 slave address are always 1, 1, and 0. Connect AD2 and AD0 to GND, V+, SDA, or SCL to select slave address bits A3, A2, A1, and A0. The MAX7322 has 16 possible slave addresses (Table 2), allowing up to 16 MAX7322 devices on an I<sup>2</sup>C bus.

**Accessing the MAX7322**

The MAX7322 is accessed through an I<sup>2</sup>C interface. The transition flags are cleared, and  $\overline{INT}$  is deasserted each time the device acknowledges the I<sup>2</sup>C slave address.

A **single-byte read** from the MAX7322 returns the status of the four input ports and the four output ports (read back as inputs).

A **2-byte read** returns the status of the four input ports and the four output ports (as for a single-byte read), followed by the transition flags for the four input ports.

A **multibyte read** (more than 2 bytes before the I<sup>2</sup>C STOP bit) repeatedly returns the port data, alternating with the transition flags. As the data is resampled for each transmission, and the transition flags are reset each time, a multibyte read continuously returns the current data and identifies any changing ports.

If a port data change occurs during the read sequence,  $\overline{INT}$  is reasserted after the I<sup>2</sup>C STOP bit. The MAX7322 does not generate another interrupt during a single-byte or multibyte read.

Port data is sampled during the preceding I<sup>2</sup>C acknowledge bit (the acknowledge bit for the I<sup>2</sup>C slave address in the case of a single-byte or 2-byte read).

A **single-byte write** to the MAX7322 sets the logic state of the four output ports and the 4-bit interrupt mask resistor, and clears both the internal transition flags and the  $\overline{INT}$  output when the device acknowledges the slave address byte.

A **multibyte write** to the MAX7322 repeatedly sets the logic state of the four output ports and the 4-bit interrupt mask register.

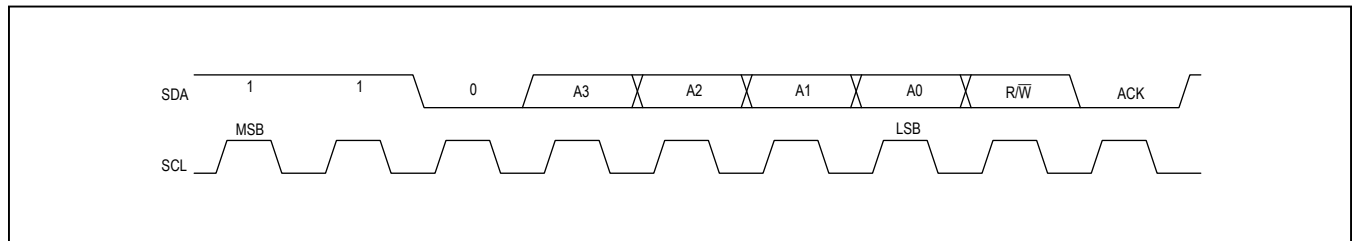

Figure 5. Slave Address

**Reading from the MAX7322**

A read from the MAX7322 starts with the master transmitting the MAX7322's slave address with the R/W bit set high. The MAX7322 acknowledges the slave address, and samples the ports during the acknowledge bit. INT deasserts during the slave address acknowledge.

Typically, the master reads one or two bytes from the MAX7322, each byte being acknowledged by the master upon reception with the exception of the last byte.

When the master reads one byte from the MAX7322 and subsequently issues a STOP condition (Figure 6),

the MAX7322 transmits the current port data, clears the change flags, and restarts the transition detection. INT deasserts during the slave address acknowledge. The new snapshot data is the current input port data transmitted to the master, so any input port changes that occur during the transmission are detected. INT remains high until the STOP condition.

The master can read two bytes from the MAX7322 and then issue a STOP condition (Figure 7). In this case, the MAX7322 transmits the current port data, followed by the change flags. The change flags are then cleared, and transition detection restarts. INT deasserts during the slave address acknowledge. The new snapshot

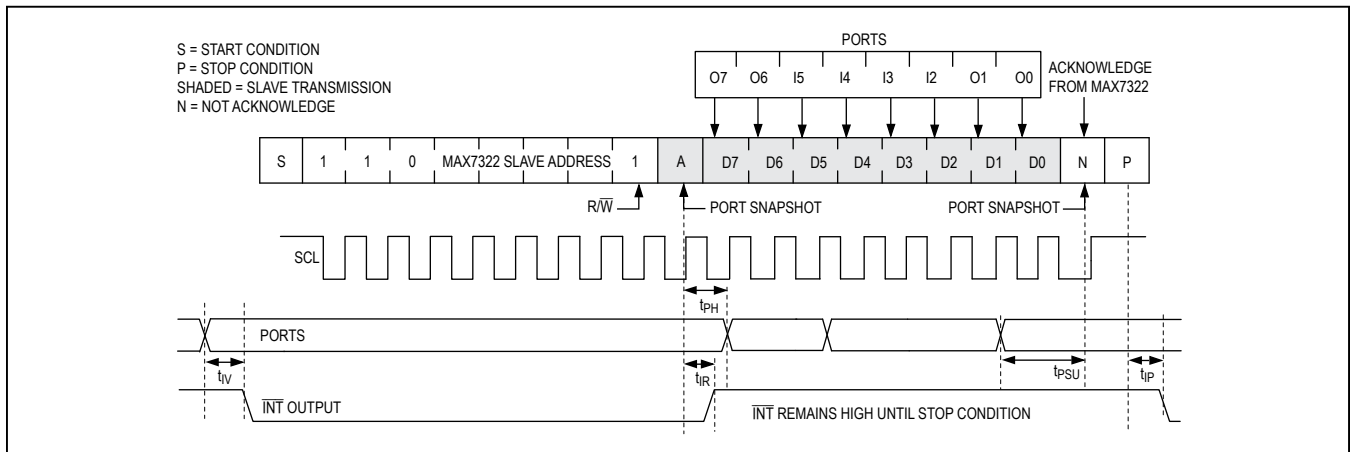

Figure 6. Reading from the MAX7322 (1 Data Byte)

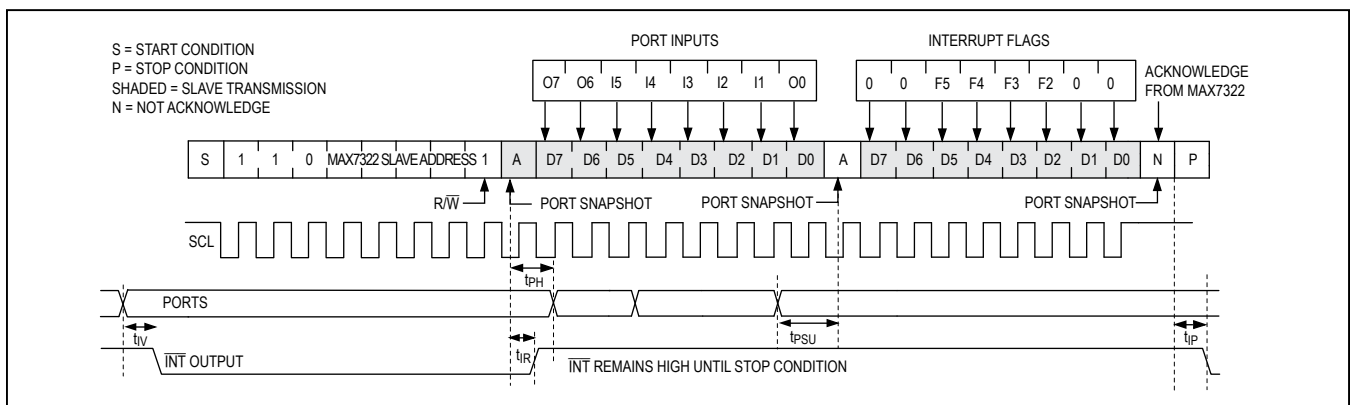

Figure 7. Reading from the MAX7322 (2 Data Bytes)

data is the current port data transmitted to the master, so any input port changes occurring during the transmission are detected.  $\overline{INT}$  remains high until the STOP condition.

**Writing to the MAX7322**

A write to the MAX7322 starts with the master transmitting the MAX7322's slave address with the R/W bit set low. The MAX7322 acknowledges the slave address, and samples the ports (takes a snapshot) during acknowledge.  $\overline{INT}$  deasserts during the slave acknowledge. The master proceeds to transmit 1 or more bytes of data. The MAX7322 acknowledges these subsequent bytes of data and updates the four output ports and the 4-bit interrupt mask register with each new byte until the master issues a STOP condition (Figure 8).

**Applications Information**

**Port Input and I<sup>2</sup>C Interface Level Translation from Higher or Lower Logic Voltages**

The MAX7322's SDA, SCL, AD0, AD2, input  $\overline{RST}$ ,  $\overline{INT}$ , and input ports I2–I5 are overvoltage protected to +6V independent of V+. This allows the MAX7322 to operate from a lower supply voltage, such as +3.3V, while the I<sup>2</sup>C interface and/or some of the four input ports are driven from a higher logic level, such as +5V.

The MAX7322 can operate from a higher supply voltage, such as +3V, while the I<sup>2</sup>C interface and/or some of the four input ports I2–I5 are driven from a lower logic level, such as +2.5V. Apply a minimum voltage of 0.7 x V+ to assert a logic-high on any input. For example, a MAX7322 operating from a +5V supply may not recognize a +3.3V nominal logic-high. One solution for input-level translation is to drive the MAX7322 inputs from open-drain outputs. Use a pullup resistor to V+ or a higher supply to ensure a high logic voltage of greater than 0.7 x V+.

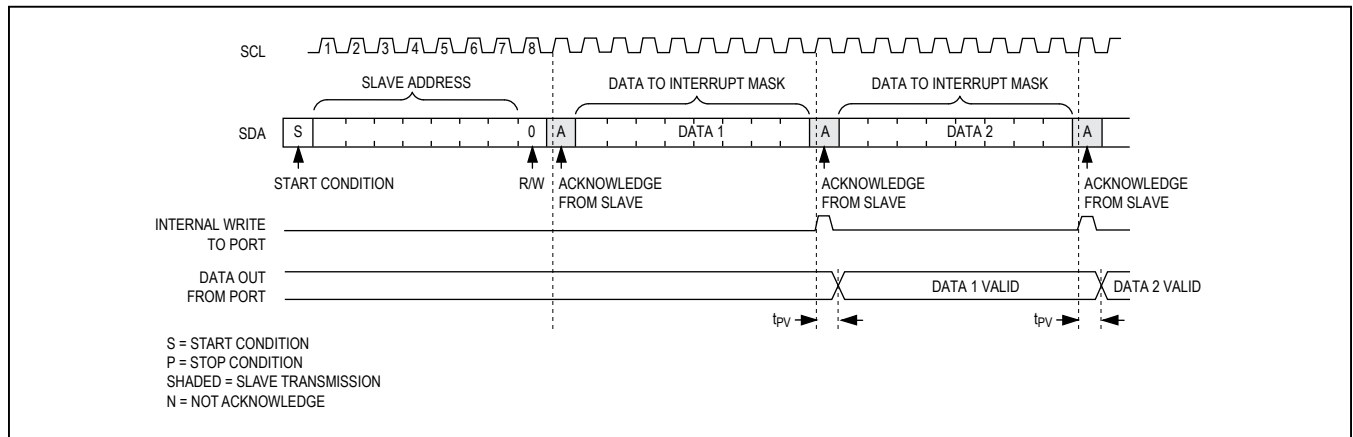

Figure 8. Writing to the MAX7322

**Port Structures**

Each of the four output ports O0, O1, O6, and O7 has protection diodes to V+ and to GND (Figure 9). When a port output is driven to a voltage lower than GND, the appropriate protection diode clamps the output to a diode drop above V+ or below GND. When the MAX7322 is powered down (V+ = 0), each output port appears as a diode clamp to GND (Figure 9).

Each of the four input ports I2–I5 has a protection diode to GND (Figure 10). When a port input is driven to a voltage lower than GND, the protection diode will clamp the input to a diode drop below GND.

Each of the four inputs ports I2–I5 also has a 40kΩ (typ) pullup resistor that can be enabled or disabled. When a port is driven to a voltage higher than V+, the body diode of the pullup enable switch conducts and the 40kΩ pullup resistor is enabled. When the MAX7322 is powered down (V+ = 0), each input port appears as a 40kΩ pullup resistor in series with a diode connected to zero. Input ports are protected to +6V under any of these circumstances (Figure 10).

**Driving LED Loads**

When driving LEDs from one of the four output ports O0, O1, O6, or O7, a resistor must be connected in series with the LED to limit the LED current to no more than 20mA. Connect the LED cathode to the MAX7322 port, and the LED anode to V+ through the series current-limiting resistor, R<sub>LED</sub>. Set the port output low to light the LED. Choose the resistor value according to the following formula:

$$R_{LED} = (V_{SUPPLY} - V_{LED} - V_{OL}) / I_{LED}$$

where:

R<sub>LED</sub> is the resistance of the resistor in series with the LED (Ω).

V<sub>SUPPLY</sub> is the supply voltage used to drive the LED (V).

V<sub>LED</sub> is the forward voltage of the LED (V).

V<sub>OL</sub> is the output low voltage of the MAX7322 when sinking I<sub>LED</sub> (V).

I<sub>LED</sub> is the desired operating current of the LED (A).

For example, to operate a 2.2V red LED at 10mA from a +5V supply:

$$R_{LED} = (5 - 2.2 - 0.07) / 0.010 = 270\Omega$$

**Driving Load Currents Higher than 20mA**

The MAX7322 can be used to drive loads, such as relays, that draw more than 20mA by paralleling outputs. Use at least one output per 20mA of load current; for example, a 5V 330mW relay draws 66mA, and

therefore, requires all four paralleled outputs. Any combination of outputs can be used as part of a load-sharing design, because any combination of ports can be set or cleared at the same time by writing to the MAX7322. Do not exceed a total sink current of 100mA for the device.

The MAX7322 must be protected from the negative voltage transient generated when switching off inductive loads (such as relays), by connecting a reverse-biased diode across the inductive load. Choose the peak current for the diode to be greater than the inductive load's operating current.

**Power-Supply Considerations**

The MAX7322 operates with a supply voltage of +1.71V to +5.5V over the -40°C to +125°C temperature range. Bypass the supply to GND with a ceramic capacitor of at least 0.047µF as close to the device as possible. For the TQFN version, additionally connect the exposed pad to GND.

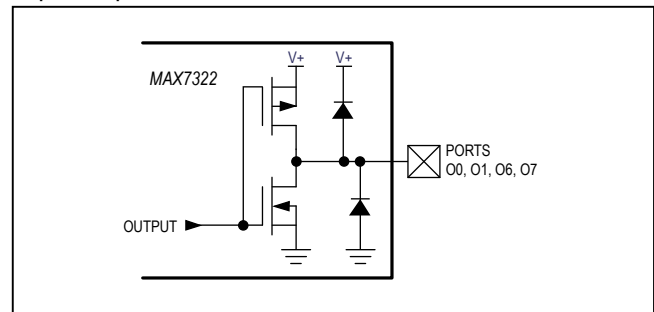

Figure 9. MAX7322 Push-Pull Output Port Structure

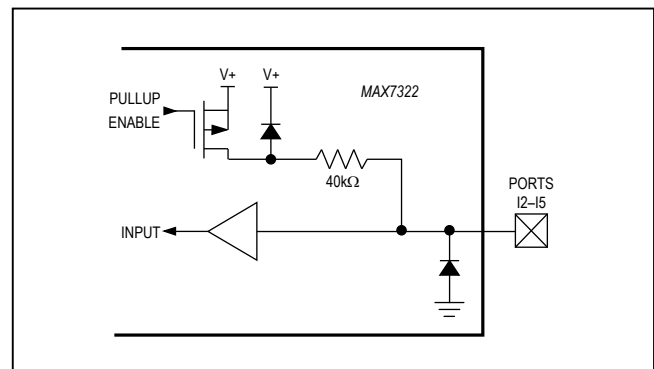
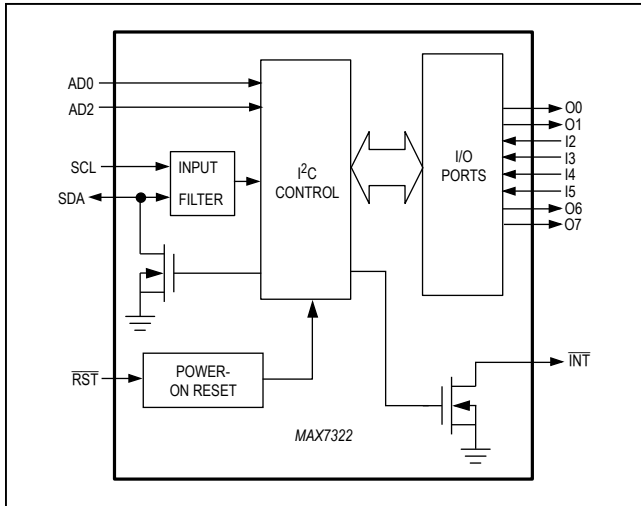
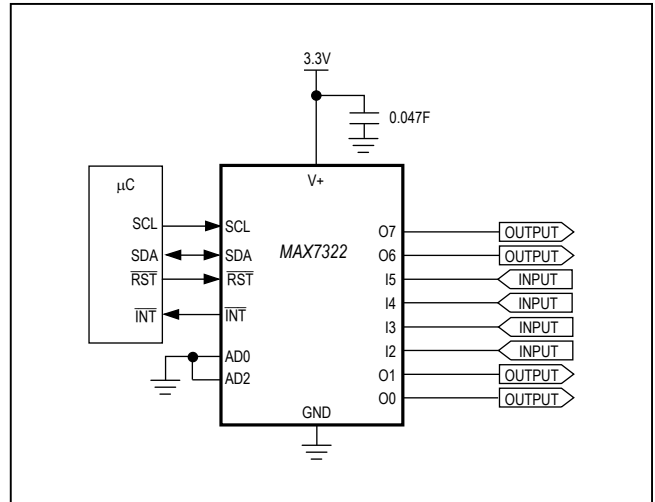

Figure 10. MAX7322 Input Port Structure

Functional Diagram



Typical Application Circuit



Pin Configurations (continued)

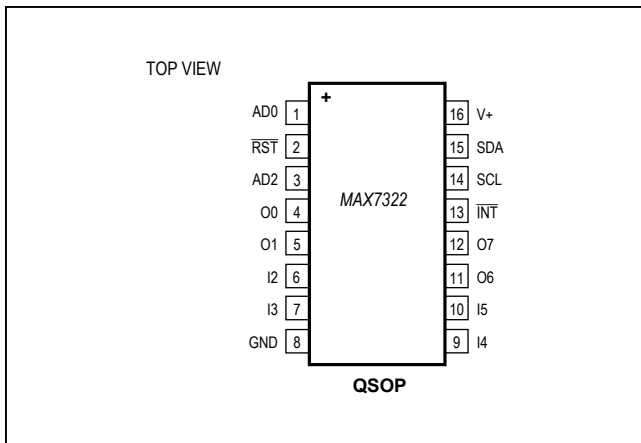

Chip Information

PROCESS: BiCMOS

Package Information

For the latest package outline information and land patterns (footprints), go to [www.maximintegrated.com/packages](http://www.maximintegrated.com/packages). Note that a "+", "#", or "-" in the package code indicates RoHS status only. Package drawings may show a different suffix character, but the drawing pertains to the package regardless of RoHS status.

PACKAGE TYPE	PACKAGE CODE	OUTLINE NO.	LAND PATTERN NO.
16 QSOP	E16+4	<a href="#">21-0055</a>	<a href="#">90-0167</a>
16 TQFN-EP	T1633+4	<a href="#">21-0136</a>	<a href="#">90-0031</a>



## Revision History

REVISION NUMBER	REVISION DATE	DESCRIPTION	PAGES CHANGED
1	7/07	—	1–17
2	5/14	No /V OPNs; removed automotive reference from <i>Applications</i> section; updated <i>Packaging Information</i>	1

For pricing, delivery, and ordering information, please contact Maxim Direct at 1-888-629-4642, or visit Maxim Integrated's website at [www.maximintegrated.com](http://www.maximintegrated.com).

*Maxim Integrated cannot assume responsibility for use of any circuitry other than circuitry entirely embodied in a Maxim Integrated product. No circuit patent licenses are implied. Maxim Integrated reserves the right to change the circuitry and specifications without notice at any time. The parametric values (min and max limits) shown in the Electrical Characteristics table are guaranteed. Other parametric values quoted in this data sheet are provided for guidance.*

Компания «Океан Электроники» предлагает заключение долгосрочных отношений при поставках импортных электронных компонентов на взаимовыгодных условиях!

Наши преимущества:

- Поставка оригинальных импортных электронных компонентов напрямую с производств Америки, Европы и Азии, а так же с крупнейших складов мира;
- Широкая линейка поставок активных и пассивных импортных электронных компонентов (более 30 млн. наименований);
- Поставка сложных, дефицитных, либо снятых с производства позиций;
- Оперативные сроки поставки под заказ (от 5 рабочих дней);
- Экспресс доставка в любую точку России;
- Помощь Конструкторского Отдела и консультации квалифицированных инженеров;
- Техническая поддержка проекта, помощь в подборе аналогов, поставка прототипов;
- Поставка электронных компонентов под контролем ВП;
- Система менеджмента качества сертифицирована по Международному стандарту ISO 9001;
- При необходимости вся продукция военного и аэрокосмического назначения проходит испытания и сертификацию в лаборатории (по согласованию с заказчиком);
- Поставка специализированных компонентов военного и аэрокосмического уровня качества (Xilinx, Altera, Analog Devices, Intersil, Interpoint, Microsemi, Actel, Aeroflex, Peregrine, VPT, Syfer, Eurofarad, Texas Instruments, MS Kennedy, Miteq, Cobham, E2V, MA-COM, Hittite, Mini-Circuits, General Dynamics и др.);

Компания «Океан Электроники» является официальным дистрибьютором и эксклюзивным представителем в России одного из крупнейших производителей разъемов военного и аэрокосмического назначения «JONHON», а так же официальным дистрибьютором и эксклюзивным представителем в России производителя высокотехнологичных и надежных решений для передачи СВЧ сигналов «FORSTAR».



## JONHON

«JONHON» (основан в 1970 г.)

Разъемы специального, военного и аэрокосмического назначения:

(Применяются в военной, авиационной, аэрокосмической, морской, железнодорожной, горно- и нефтедобывающей отраслях промышленности)

«FORSTAR» (основан в 1998 г.)

ВЧ соединители, коаксиальные кабели, кабельные сборки и микроволновые компоненты:

(Применяются в телекоммуникациях гражданского и специального назначения, в средствах связи, РЛС, а так же военной, авиационной и аэрокосмической отраслях промышленности).



Телефон: 8 (812) 309-75-97 (многоканальный)

Факс: 8 (812) 320-03-32

Электронная почта: [ocean@oceanchips.ru](mailto:ocean@oceanchips.ru)

Web: <http://oceanchips.ru/>

Адрес: 198099, г. Санкт-Петербург, ул. Калинина, д. 2, корп. 4, лит. А