

LT8364

Low I_Q Boost/SEPIC/Inverting Regulator

DESCRIPTION

Demo circuit 2716A features the [LT8364](#) in boost configuration. It is designed to convert a 4.5V to 20V source to 24V, with up to 1.6A, depending on input voltage, with a switching frequency of 2MHz. The LT8364 can operate with inputs as high as 60V, however, in this demo circuit, the input is limited by the level of the output voltage. Refer to Figure 4 for load current versus input voltage.

The demo board contains a selectable jumper, JP1, to aid in the selection of the desired Sync pin mode of operation. The default setting is Burst Mode[®] operation.

This layout is optimized for good EMI performance and solution size. Input and output filters and an optimized

hot loop, comprised of C11 and C12 are necessary to pass CISPR 25 Class 5 emissions, and are added by default. These components can be excluded in applications not requiring noise immunity. Radiated emissions plots are included in this manual.

The data sheet gives a complete description of the device, operation and application information. The data sheet must be read in conjunction with this demo manual.

Design files for this circuit board are available at <http://www.linear.com/demo/DC2716A>

LT, LT, LTC, LTM, Linear Technology, the Linear logo and Burst Mode are registered trademarks of Analog Devices, Inc. All other trademarks are the property of their respective owners.

PERFORMANCE SUMMARY Specifications are at $T_A = 25^\circ\text{C}$

SYMBOL	PARAMETER	CONDITIONS	MIN	TYP	MAX	UNITS
V_{IN}	Input Supply Range		4.5		20	V
V_{OUT}	Output Voltage Range	$V_{IN} = 12\text{V}, I_{LOAD} = 1.2\text{A}$	23.25	24	24.75	V
RIPPLE		$V_{IN} = 12\text{V}, I_{LOAD} = 1.2\text{A}$		50		mV
EFFICIENCY		$V_{IN} = 12\text{V}, I_{LOAD} = 1\text{A}$		93		%
f_{SW}				2		MHz

QUICK START PROCEDURE

Demo circuit 2716A is easy to set up to evaluate the performance of the LT8364. Refer to Figure 1 for proper measurement equipment setup and follow the procedure below:

NOTE: When measuring the input or output voltage ripple, care must be taken to avoid a long ground lead on the oscilloscope probe. Measure the input or output voltage ripple by touching the probe tip directly across the V_{IN} or V_{OUT} and GND terminals. See Figure 2 for proper scope probe technique.

1. With power off, connect the input power supply to V_{IN} and GND.

2. Turn on the power at the input.

Note. Make sure that the input voltage does not exceed 20V.

3. Check for the proper output voltage.

If there is no output, temporarily disconnect the load to make sure that the load is not set too high.

NOTE:

4. Once the proper output voltage is established, adjust the load within the operating range and observe the output voltage regulation, ripple voltage, efficiency and other parameters.

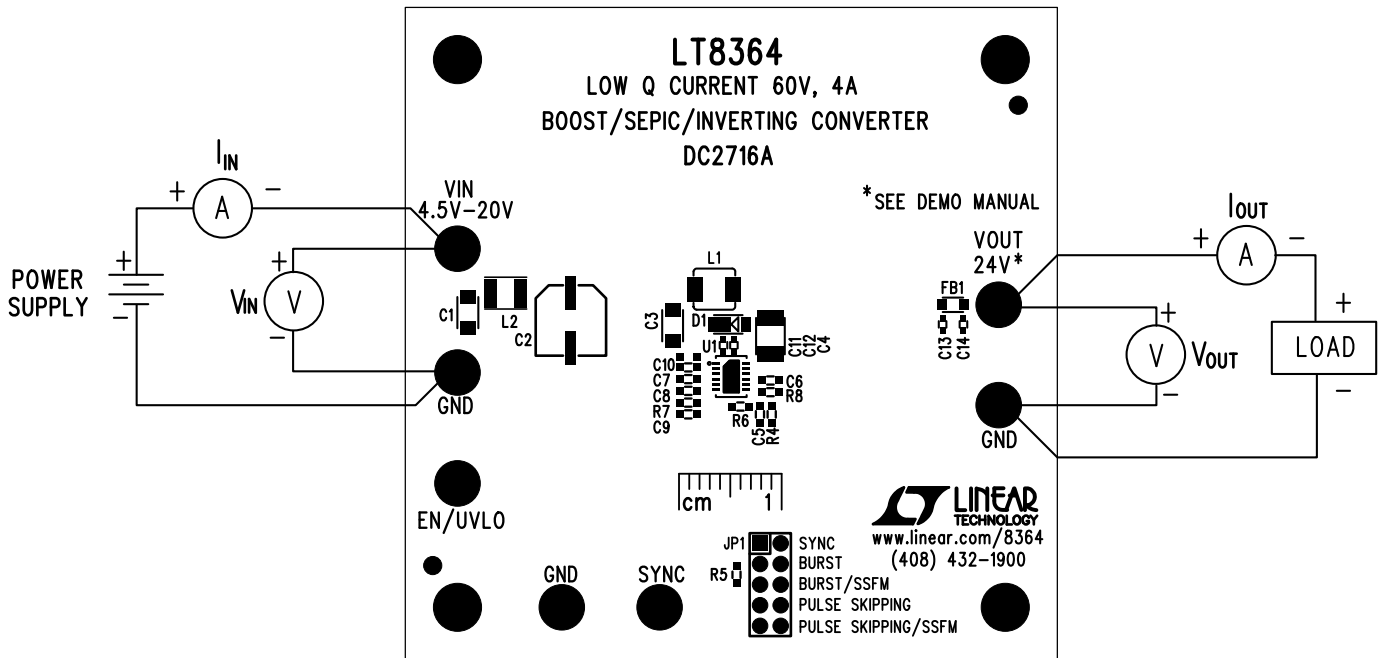

Figure 1. DC2716A Proper Equipment Setup

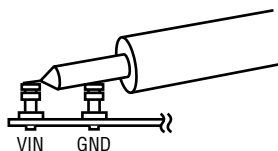

Figure 2. Measure Output Ripple

QUICK START PROCEDURE

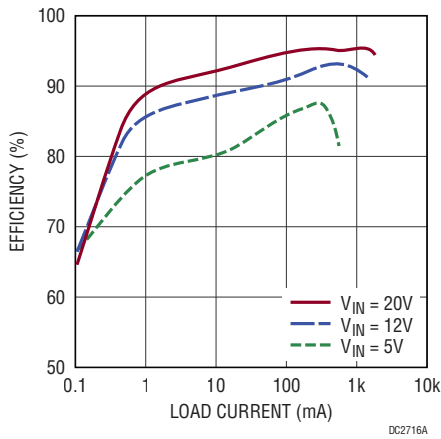

Figure 3. Efficiency Versus Load Current

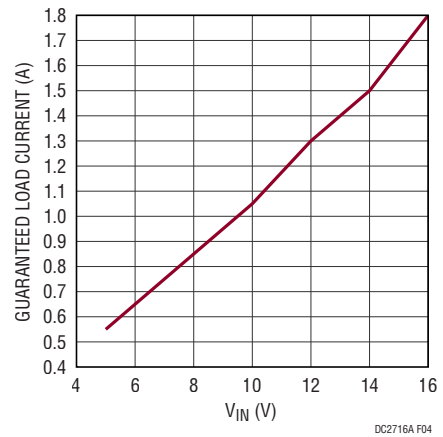

Figure 4. Guaranteed Load Current Versus Input Voltage

TYPICAL PERFORMANCE CHARACTERISTICS

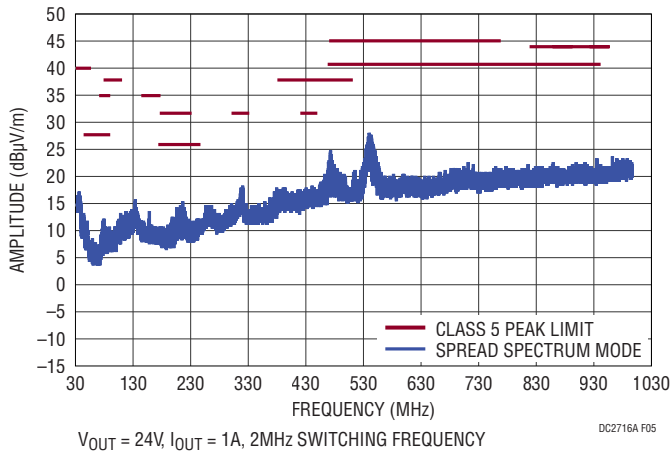

Figure 5. CISPR 25 Radiated Emission Test Peak Detection, Vertical Polarization) $V_{IN} = 12V$

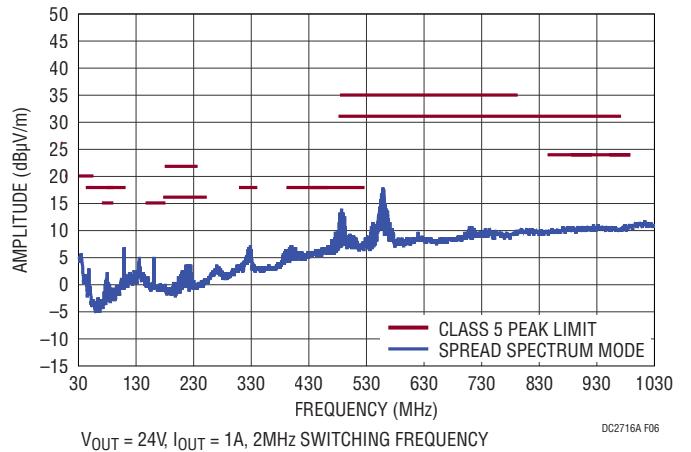

Figure 6. CISPR 25 Radiated Emission Test (Average Detection, Vertical Polarization) $V_{IN} = 12V$

DEMO MANUAL DC2716A

PARTS LIST

ITEM	QTY	REFERENCE	PART DESCRIPTION	MANUFACTURER/PART NUMBER
Required Circuit Components				
1	1	C1	CAP., 4.7μF, X7R, 25V, 10%, 1206	MURATA, GRM31CR71E475KA88L
2	1	C2	CAP., 33μF, ALUM. ELECT., 50V, 20%	SUN ELECTRONIC INDUSTRIES CORP., 50CE33PCS
3	1	C3	CAP., 10μF, X7R, 25V, 10%, 1206	MURATA, GRM31CR71E106KA12L
4	1	C4	CAP., 10μF, X7S, 50V, 10%, 1210	MURATA, GCM32EC71H106KA03L
5	1	C6	CAP., 0.22μF, X7R, 25V, 10%, 0603	MURATA, GRM188R71E224KA88D
6	1	C7	CAP., 1μF, X5R, 25V, 10%, 0603	MURATA, GRM188R61E105KA12D
7	1	C9	CAP., 2200pF, X7R, 25V, 10%, 0603	MURATA, GRM188R71E222KA01D
8	1	C10	CAP., 1μF, X5R, 50V, 10%, 0603	MURATA, GRM188R61H105KAALD
9	4	C11, C12, C13, C14	CAP., 0.1μF, X7R, 50V, 10%, 0402, AEC-Q200	MURATA, GCM155R71H104KE02D
10	1	D1	DIODE, SCHOTTKY, 60V, 2.0A, POWERDI 123	DIODES INC., DFSL260-7
11	1	FB1	IND., 600Ω, FERRITE BEAD, 25%, 2A, 0805	WURTH ELEKTRONIK, 742792040
12	1	L1	IND., 2.2μH, 3.25A, 61mΩ, SMD	WURTH ELECTRONICS INC., 74437324022
13	1	L2	IND., 470nH, 3.6A, 31mΩ, SMD	WURTH ELEKTRONIK, 74479299147
14	2	R1, R4	RES., 1MΩ, 1%, 1/10W, 0603	VISHAY, CRCW06031M00FKEA
15	1	R3	RES., 732k, 1%, 1/10W, 0603	VISHAY, CRCW0603732KFKEA
16	1	R5	RES., 100k, 1%, 1/10W, 0603	VISHAY, CRCW0603100KFKEA
17	1	R6	RES., 71.5k, 1%, 1/10W, 0603	VISHAY, CRCW060371K5FKEA
18	1	R7	RES., 22k, 1%, 1/10W, 0603	VISHAY, CRCW060322K0FKEA
19	1	R8	RES., 20k, 1%, 1/10W, 0603	VISHAY, CRCW060320K0FKEA
20	1	U1	IC, BOOST/SEPIC/INVERTING CONVERTER	LINEAR TECH., LT8364EDE
Additional Demo Board Circuit Components				
1	1	R2	RES., 0Ω, 1/10W, 0603	VISHAY, CRCW06030000Z0EA
2	1	C5 (OPT)	CAP, OPT, 0603	
3	0	C8	CAP, OPTION, 0603	
Hardware: For Demo Board Only				
1	7	E1, E2, E3, E4, E5, E6, E7	TEST POINT, TURRET, 0.094", MTG. HOLE	MILL-MAX, 2501-2-00-80-00-00-07-0
2	1	JP1	CONN., HEADER, MALE, 2 × 5.2mm, ST, THT	WURTH ELEKTRONIK, 62001021121
3	1	XJP1	CONN., SHUNT, FEMALE, 2 POS, 2mm	WURTH ELEKTRONIK, 60800213421
4	4	MP1, MP2, MP3, MP4	STANDOFF, NYLON, 0.50"	KEYSTONE, 8833

SCHEMATIC DIAGRAM

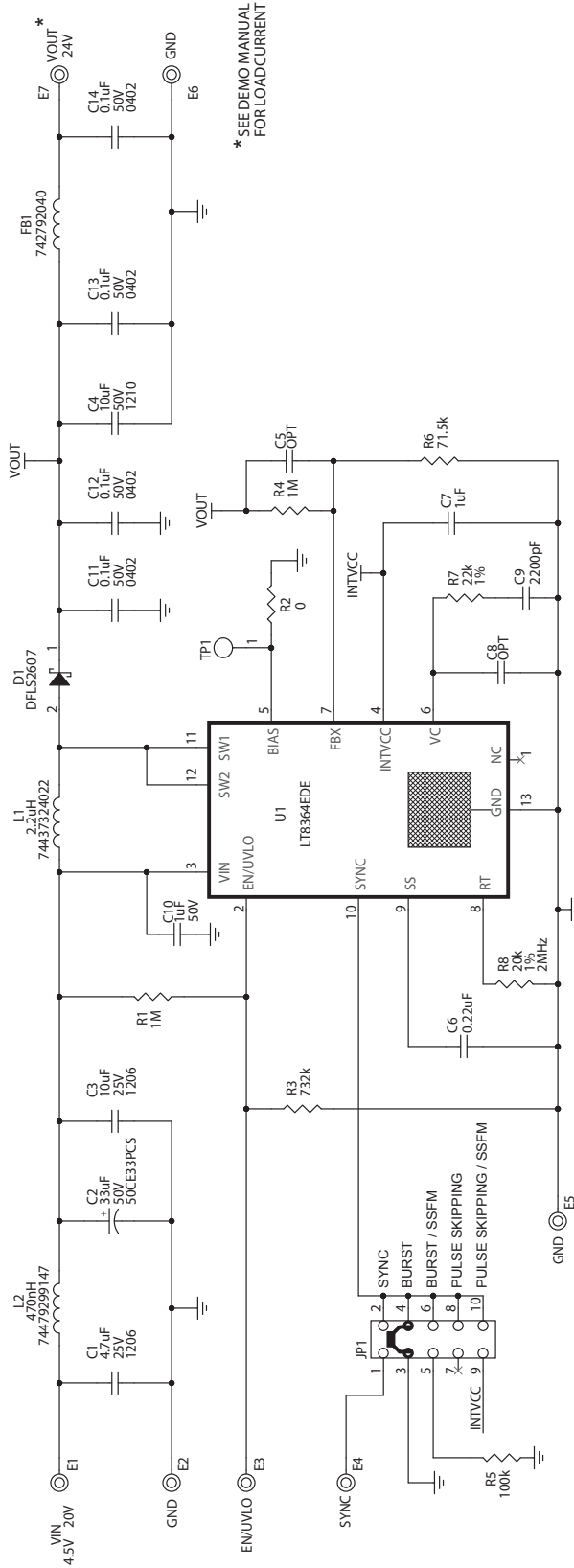

* SEE DEMO MANUAL FOR LOAD CURRENT

NOTES: UNLESS OTHERWISE SPECIFIED
 1. ALL RESISTORS ARE 0603.
 ALL CAPACITORS ARE 0603.

DEMO MANUAL DC2716A

DEMONSTRATION BOARD IMPORTANT NOTICE

Linear Technology Corporation (LTC) provides the enclosed product(s) under the following **AS IS** conditions:

This demonstration board (DEMO BOARD) kit being sold or provided by Linear Technology is intended for use for **ENGINEERING DEVELOPMENT OR EVALUATION PURPOSES ONLY** and is not provided by LTC for commercial use. As such, the DEMO BOARD herein may not be complete in terms of required design-, marketing-, and/or manufacturing-related protective considerations, including but not limited to product safety measures typically found in finished commercial goods. As a prototype, this product does not fall within the scope of the European Union directive on electromagnetic compatibility and therefore may or may not meet the technical requirements of the directive, or other regulations.

If this evaluation kit does not meet the specifications recited in the DEMO BOARD manual the kit may be returned within 30 days from the date of delivery for a full refund. **THE FOREGOING WARRANTY IS THE EXCLUSIVE WARRANTY MADE BY THE SELLER TO BUYER AND IS IN LIEU OF ALL OTHER WARRANTIES, EXPRESSED, IMPLIED, OR STATUTORY, INCLUDING ANY WARRANTY OF MERCHANTABILITY OR FITNESS FOR ANY PARTICULAR PURPOSE. EXCEPT TO THE EXTENT OF THIS INDEMNITY, NEITHER PARTY SHALL BE LIABLE TO THE OTHER FOR ANY INDIRECT, SPECIAL, INCIDENTAL, OR CONSEQUENTIAL DAMAGES.**

The user assumes all responsibility and liability for proper and safe handling of the goods. Further, the user releases LTC from all claims arising from the handling or use of the goods. Due to the open construction of the product, it is the user's responsibility to take any and all appropriate precautions with regard to electrostatic discharge. Also be aware that the products herein may not be regulatory compliant or agency certified (FCC, UL, CE, etc.).

No License is granted under any patent right or other intellectual property whatsoever. **LTC assumes no liability for applications assistance, customer product design, software performance, or infringement of patents or any other intellectual property rights of any kind.**

LTC currently services a variety of customers for products around the world, and therefore this transaction **is not exclusive**.

Please read the DEMO BOARD manual prior to handling the product. Persons handling this product must have electronics training and observe good laboratory practice standards. **Common sense is encouraged.**

This notice contains important safety information about temperatures and voltages. For further safety concerns, please contact a LTC application engineer.

Mailing Address:

Linear Technology
1630 McCarthy Blvd.
Milpitas, CA 95035

Copyright © 2004, Linear Technology Corporation

Компания «Океан Электроники» предлагает заключение долгосрочных отношений при поставках импортных электронных компонентов на взаимовыгодных условиях!

Наши преимущества:

- Поставка оригинальных импортных электронных компонентов напрямую с производств Америки, Европы и Азии, а так же с крупнейших складов мира;
- Широкая линейка поставок активных и пассивных импортных электронных компонентов (более 30 млн. наименований);
- Поставка сложных, дефицитных, либо снятых с производства позиций;
- Оперативные сроки поставки под заказ (от 5 рабочих дней);
- Экспресс доставка в любую точку России;
- Помощь Конструкторского Отдела и консультации квалифицированных инженеров;
- Техническая поддержка проекта, помощь в подборе аналогов, поставка прототипов;
- Поставка электронных компонентов под контролем ВП;
- Система менеджмента качества сертифицирована по Международному стандарту ISO 9001;
- При необходимости вся продукция военного и аэрокосмического назначения проходит испытания и сертификацию в лаборатории (по согласованию с заказчиком);
- Поставка специализированных компонентов военного и аэрокосмического уровня качества (Xilinx, Altera, Analog Devices, Intersil, Interpoint, Microsemi, Actel, Aeroflex, Peregrine, VPT, Syfer, Eurofarad, Texas Instruments, MS Kennedy, Miteq, Cobham, E2V, MA-COM, Hittite, Mini-Circuits, General Dynamics и др.);

Компания «Океан Электроники» является официальным дистрибьютором и эксклюзивным представителем в России одного из крупнейших производителей разъемов военного и аэрокосмического назначения «JONHON», а так же официальным дистрибьютором и эксклюзивным представителем в России производителя высокотехнологичных и надежных решений для передачи СВЧ сигналов «FORSTAR».



JONHON

«JONHON» (основан в 1970 г.)

Разъемы специального, военного и аэрокосмического назначения:

(Применяются в военной, авиационной, аэрокосмической, морской, железнодорожной, горно- и нефтедобывающей отраслях промышленности)

«FORSTAR» (основан в 1998 г.)

ВЧ соединители, коаксиальные кабели,
кабельные сборки и микроволновые компоненты:

(Применяются в телекоммуникациях гражданского и специального назначения, в средствах связи, РЛС, а так же военной, авиационной и аэрокосмической отраслях промышленности).



Телефон: 8 (812) 309-75-97 (многоканальный)

Факс: 8 (812) 320-03-32

Электронная почта: ocean@oceanchips.ru

Web: <http://oceanchips.ru/>

Адрес: 198099, г. Санкт-Петербург, ул. Калинина, д. 2, корп. 4, лит. А