



**MCP73837/8**  
**AC/USB**  
**Dual Input Battery Charger**  
**Evaluation Board**  
**User's Guide**

---

**Note the following details of the code protection feature on Microchip devices:**

- Microchip products meet the specification contained in their particular Microchip Data Sheet.
- Microchip believes that its family of products is one of the most secure families of its kind on the market today, when used in the intended manner and under normal conditions.
- There are dishonest and possibly illegal methods used to breach the code protection feature. All of these methods, to our knowledge, require using the Microchip products in a manner outside the operating specifications contained in Microchip's Data Sheets. Most likely, the person doing so is engaged in theft of intellectual property.
- Microchip is willing to work with the customer who is concerned about the integrity of their code.
- Neither Microchip nor any other semiconductor manufacturer can guarantee the security of their code. Code protection does not mean that we are guaranteeing the product as "unbreakable."

Code protection is constantly evolving. We at Microchip are committed to continuously improving the code protection features of our products. Attempts to break Microchip's code protection feature may be a violation of the Digital Millennium Copyright Act. If such acts allow unauthorized access to your software or other copyrighted work, you may have a right to sue for relief under that Act.

---

Information contained in this publication regarding device applications and the like is provided only for your convenience and may be superseded by updates. It is your responsibility to ensure that your application meets with your specifications. MICROCHIP MAKES NO REPRESENTATIONS OR WARRANTIES OF ANY KIND WHETHER EXPRESS OR IMPLIED, WRITTEN OR ORAL, STATUTORY OR OTHERWISE, RELATED TO THE INFORMATION, INCLUDING BUT NOT LIMITED TO ITS CONDITION, QUALITY, PERFORMANCE, MERCHANTABILITY OR FITNESS FOR PURPOSE. Microchip disclaims all liability arising from this information and its use. Use of Microchip devices in life support and/or safety applications is entirely at the buyer's risk, and the buyer agrees to defend, indemnify and hold harmless Microchip from any and all damages, claims, suits, or expenses resulting from such use. No licenses are conveyed, implicitly or otherwise, under any Microchip intellectual property rights.

**Trademarks**

The Microchip name and logo, the Microchip logo, Accuron, dsPIC, KEELOQ, KEELOQ logo, microID, MPLAB, PIC, PICmicro, PICSTART, PRO MATE, rfPIC and SmartShunt are registered trademarks of Microchip Technology Incorporated in the U.S.A. and other countries.

AmpLab, FilterLab, Linear Active Thermistor, Migratable Memory, MXDEV, MXLAB, SEEVAL, SmartSensor and The Embedded Control Solutions Company are registered trademarks of Microchip Technology Incorporated in the U.S.A.

Analog-for-the-Digital Age, Application Maestro, CodeGuard, dsPICDEM, dsPICDEM.net, dsPICworks, dsSPEAK, ECAN, ECONOMONITOR, FanSense, FlexROM, fuzzyLAB, In-Circuit Serial Programming, ICSP, ICEPIC, Mindi, MiWi, MPASM, MPLAB Certified logo, MPLIB, MPLINK, PCKit, PICDEM, PICDEM.net, PICLAB, PICTail, PowerCal, PowerInfo, PowerMate, PowerTool, REAL ICE, rfLAB, Select Mode, Smart Serial, SmartTel, Total Endurance, UNI/O, WiperLock and ZENA are trademarks of Microchip Technology Incorporated in the U.S.A. and other countries.

SQTP is a service mark of Microchip Technology Incorporated in the U.S.A.

All other trademarks mentioned herein are property of their respective companies.

© 2007, Microchip Technology Incorporated, Printed in the U.S.A., All Rights Reserved.

 Printed on recycled paper.

**QUALITY MANAGEMENT SYSTEM  
CERTIFIED BY DNV  
== ISO/TS 16949:2002 ==**

*Microchip received ISO/TS-16949:2002 certification for its worldwide headquarters, design and wafer fabrication facilities in Chandler and Tempe, Arizona; Gresham, Oregon and design centers in California and India. The Company's quality system processes and procedures are for its PIC® MCUs and dsPIC® DSCs, KEELOQ® code hopping devices, Serial EEPROMs, microperipherals, nonvolatile memory and analog products. In addition, Microchip's quality system for the design and manufacture of development systems is ISO 9001:2000 certified.*



# MCP73837/8 AC/USB EVALUATION BOARD USER'S GUIDE

---

---

## Table of Contents

---

---

<b>Preface</b> .....	<b>1</b>
Introduction.....	1
Document Layout .....	1
Conventions Used in this Guide .....	2
Recommended Reading.....	2
The Microchip Web Site .....	3
Customer Support .....	3
Document Revision History .....	3
<b>Chapter 1. Product Overview</b>	
1.1 Introduction .....	5
1.2 What is the MCP73837/8 AC/USB Dual Input Battery Charger Evaluation Board? .....	6
1.3 What the MCP73837/8 AC/USB Dual Input Battery Charger Evaluation Board Kit Includes .....	6
<b>Chapter 2. Installation and Operation</b>	
2.1 Introduction .....	7
2.2 Features .....	7
2.3 Getting Started .....	8
<b>Appendix A. Schematic and Layouts</b>	
A.1 Introduction .....	11
A.2 Board – Schematic .....	12
A.3 Board – Top Layer .....	13
A.4 Board – Top Metal Layer .....	14
A.5 Board – Bottom Layer .....	15
<b>Appendix B. Bill Of Materials (BOM)</b>	
<b>Worldwide Sales and Service</b> .....	<b>18</b>

# MCP73837/8 AC/USB Evaluation Board User's Guide

---

NOTES:



# MCP73837/8 AC/USB EVALUATION BOARD USER'S GUIDE

## Preface

### NOTICE TO CUSTOMERS

All documentation becomes dated, and this manual is no exception. Microchip tools and documentation are constantly evolving to meet customer needs, so some actual dialogs and/or tool descriptions may differ from those in this document. Please refer to our web site ([www.microchip.com](http://www.microchip.com)) to obtain the latest documentation available.

Documents are identified with a "DS" number. This number is located on the bottom of each page, in front of the page number. The numbering convention for the DS number is "DSXXXXA", where "XXXX" is the document number and "A" is the revision level of the document.

For the most up-to-date information on development tools, see the MPLAB® IDE on-line help. Select the Help menu, and then Topics to open a list of available on-line help files.

## INTRODUCTION

This chapter contains general information that will be useful to know before using the MCP73837/8 AC/USB Dual Input Battery Charger Evaluation Board. Items discussed in this chapter include:

- Document Layout
- Conventions Used in this Guide
- Recommended Reading
- The Microchip Web Site
- Customer Support
- Document Revision History

## DOCUMENT LAYOUT

This document describes how to use the MCP73837/8 AC/USB Dual Input Battery Charger Evaluation Board. The manual layout is as follows:

- **Chapter 1. "Product Overview"** – Important information about the MCP73837/8 AC/USB Dual Input Battery Charger Evaluation Board.
- **Chapter 2. "Installation and Operation"** – Includes instructions on how to get started with this user's guide and a description of the user's guide.
- **Appendix A. "Schematic and Layouts"** – Shows the schematic and layout diagrams for the MCP73837/8 AC/USB Dual Input Battery Charger Evaluation Board.
- **Appendix B. "Bill Of Materials (BOM)"** – Lists the parts used to build the MCP73837/8 AC/USB Dual Input Battery Charger Evaluation Board.

# MCP73837/8 AC/USB Evaluation Board User's Guide

## CONVENTIONS USED IN THIS GUIDE

This manual uses the following documentation conventions:

### DOCUMENTATION CONVENTIONS

Description	Represents	Examples
<b>Arial font:</b>		
Italic characters	Referenced books	<i>MPLAB<sup>®</sup> IDE User's Guide</i>
	Emphasized text	...is the <i>only</i> compiler...
Initial caps	A window	the Output window
	A dialog	the Settings dialog
	A menu selection	select Enable Programmer
Quotes	A field name in a window or dialog	"Save project before build"
Underlined, italic text with right angle bracket	A menu path	<u><i>File&gt;Save</i></u>
Bold characters	A dialog button	Click <b>OK</b>
	A tab	Click the <b>Power</b> tab
N'Rnnnn	A number in verilog format, where N is the total number of digits, R is the radix and n is a digit.	4'b0010, 2'hF1
Text in angle brackets < >	A key on the keyboard	Press <Enter>, <F1>
<b>Courier New font:</b>		
Plain Courier New	Sample source code	#define START
	Filenames	autoexec.bat
	File paths	c:\mcc18\h
	Keywords	_asm, _endasm, static
	Command-line options	-Opa+, -Opa-
	Bit values	0, 1
	Constants	0xFF, 'A'
Italic Courier New	A variable argument	<i>file.o</i> , where <i>file</i> can be any valid filename
Square brackets [ ]	Optional arguments	mcc18 [options] <i>file</i> [options]
Curly brackets and pipe character: {   }	Choice of mutually exclusive arguments; an OR selection	errorlevel {0 1}
Ellipses...	Replaces repeated text	var_name [, var_name...]
	Represents code supplied by user	void main (void) { ... }

## RECOMMENDED READING

This user's guide describes how to use MCP73837/8 AC/USB Dual Input Battery Charger Evaluation Board. Other useful documents are listed below. The following Microchip documents are available and recommended as supplemental reference resources.

**MCP73837/8 Data Sheet, "Advanced Stand-Alone Li-Ion / Li-Polymer Battery Charge Management Controller with Autonomous AC-Adapter or USB-Port Source Selection", DS22071**

This data sheet provides detailed information regarding the MCP73837/8 product family.

## THE MICROCHIP WEB SITE

Microchip provides online support via our web site at [www.microchip.com](http://www.microchip.com). This web site is used as a means to make files and information easily available to customers. Accessible by using your favorite Internet browser, the web site contains the following information:

- **Product Support** – Data sheets and errata, application notes and sample programs, design resources, user's guides and hardware support documents, latest software releases and archived software
- **General Technical Support** – Frequently Asked Questions (FAQs), technical support requests, online discussion groups, Microchip consultant program member listing
- **Business of Microchip** – Product selector and ordering guides, latest Microchip press releases, listing of seminars and events, listings of Microchip sales offices, distributors and factory representatives

## CUSTOMER SUPPORT

Users of Microchip products can receive assistance through several channels:

- Distributor or Representative
- Local Sales Office
- Field Application Engineer (FAE)
- Technical Support

Customers should contact their distributor, representative or field application engineer for support. Local sales offices are also available to help customers. A listing of sales offices and locations is included in the back of this document.

Technical support is available through the web site at: <http://support.microchip.com>

## DOCUMENT REVISION HISTORY

### Revision A (December 2007)

- Initial Release of this Document.

# MCP73837/8 AC/USB Evaluation Board User's Guide

---

NOTES:



**Chapter 1. Product Overview**

**1.1 INTRODUCTION**

The MCP73837/8 AC/USB Dual Input Battery Charger Evaluation Board demonstrates the features and abilities of Microchip's MCP73837 and MCP73838 Single-Chip Linear Li-Ion Battery Charger with Autonomous AC Adapter or USB-Port Power Source Selection. The MCP73837 and MCP73838 are stand-alone highly integrated linear battery charger management controllers which employ a constant current / constant voltage (CCCV) charge algorithm with selectable preconditioning and charge termination ratio.

The MCP73837 and MCP73838 automatically select the AC-Adapter or USB-Port as the power source for the system. For an AC-Adapter powered system, an external resistor ( $R_{PROG}$ ) sets the magnitude of the charge current up to a maximum of 1000 mA. With an USB-port providing power to the system, the MCP73837/8 specifically adheres to the current limits governed by the USB specification. The host microcontroller can select from two preset charge current rates of typical 90 mA (low) or 450 mA (High) and will not exceed 100 mA (Low) or 500 mA (high) maximum charge current. As for USB regulation, a device may draw either low-power at one unit load or high-power at 5 unit loads. A unit load is defined to be 100 mA. The drawn current per unit load is an absolute maximum value, not an average over time.

This chapter covers the following topics:

- What is the MCP73837/8 AC/USB Dual Input Battery Charger Evaluation Board?
- What the MCP73837/8 AC/USB Dual Input Battery Charger Evaluation Board Kit includes.

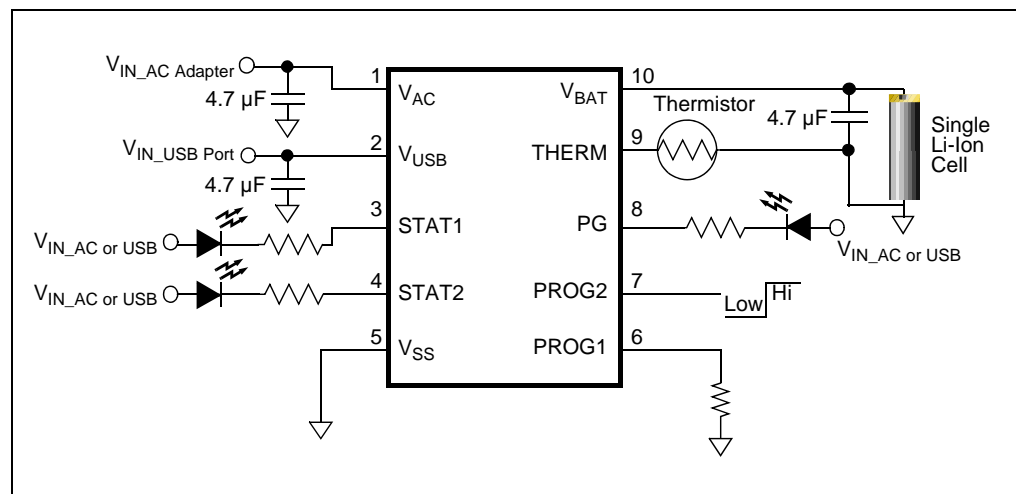

**FIGURE 1-1:** MCP73837 Typical Application.

# MCP73837/8 AC/USB Evaluation Board User's Guide

---

## 1.2 WHAT IS THE MCP73837/8 AC/USB DUAL INPUT BATTERY CHARGER EVALUATION BOARD?

The MCP73837/8 AC/USB Dual Input Battery Charger Evaluation Board demonstrates the use of Single-Chip Linear Li-Ion Battery Charger with Autonomous AC-Adapter or USB-Port Power Source Selection.

The MCP73837/8 AC/USB Dual Input Battery Charger Evaluation Board is set up to evaluate single-cell Li-Ion Battery Charge Management. This board utilizes Microchip's MCP73837 and MCP73838 (Li-Ion Battery Charge Management Controllers) that effectively charge Li-Ion batteries with  $\pm 0.5\%$  high accuracy preset voltage regulation. The MCP73837/8 AC/USB Dual Input Battery Charger Evaluation Board comes with two pre-installed circuits: DFN-10 MCP73837 and MSOP-10 MCP73838. Both circuits are ready to charge Li-Ion battery at a maximum charge current rate up to 1000 mA when AC Adapter is present and a maximum charge current rate up to 500 mA when USB-Port is present. A mechanical dip switch is built in to select High (maximum 500 mA) or Low (maximum 100 mA) for the USB-Port powered system.

Two built-in LEDs are ready to indicate charge status: STAT1 and STAT2. The MCP73837 has a Power-Good Monitor that can be observed via the 3rd LED indicator on the board.

**Note:** Please refer to [Table 2-1](#) for MCP73837/8 Charge Status Outputs.

The MCP73838 has Timer-Enable to active and disable the internal safety timer for charge special applications which can be selected from  $\overline{TE}$  test point pin.

The MCP73837/8 AC/USB Dual Input Battery Charger Evaluation Board is also designed for easy modifications to support both MCP73837 in 10-pin DFN and MSOP packages and MCP73838 in 10-pin DFN and MSOP packages.  $R_{PROG}$  (R6 and R12) are located in the open area for quick charge current programming.

The MCP73837/8 AC/USB Dual Input Battery Charger Evaluation Board is designed to observe the performance and features on the circuits via multiple test points. Users can also discover the compact size of the layout in addition to the device itself. The circuit can also be implemented into suitable applications without additional work.

## 1.3 WHAT THE MCP73837/8 AC/USB DUAL INPUT BATTERY CHARGER EVALUATION BOARD KIT INCLUDES

This MCP73837/8 AC/USB Dual Input Battery Charger Evaluation Board kit includes:

- MCP73837/8 AC/USB Dual Input Battery Charger Evaluation Board, 102-00120
- MCP73837 DFN-10 and MCP73838 MSOP-10 (Pre-Installed)
- Analog and Interface Products Demonstration Boards CD-ROM (DS21912)
  - MCP73837/8 AC/USB Evaluation Board User's Guide, DS51684

---

---

## Chapter 2. Installation and Operation

---

---

### 2.1 INTRODUCTION

The MCP73837/8 AC/USB Dual Input Battery Charger Evaluation Board demonstrates Microchip's stand-alone Linear Li-Ion Battery Chargers - MCP73837 and MCP73838. The MCP73837 device features a Power-Good Monitor while the MCP73838 device uses the same pin for the Timer-Enable function.

The MCP73837/8 require only minimum components to implement a complete battery charge management circuit. The MCP73837/8 are designed to select AC-Adapter or USB-Port Power Source automatically where AC-Adapter provides the charge current when both sources are present.

The MCP73837/8 AC/USB Dual Input Battery Charger Evaluation Board comes with a 10-pin DFN MCP73837 and a 10-pin MSOP MCP73838 pre-installed. The different packages can be easily evaluated by replacing the device, a resistor and a LED where the patterns have been pre-designed on the board layout.

Typical applications for the MCP73837/8 devices are Smart Phones, PDA, Portable Media Players, MP3 Players, USB-Powered Systems, Digital Cameras, Handheld Medical Instruments, Handheld Devices, Battery Chargers, Bluetooth headsets, Ultra-Mobile PC and Portable Communicators.

### 2.2 FEATURES

The MCP73837/8 AC/USB Dual Input Battery Charger Evaluation Board has the following features:

- DFN-10 and MSOP-10 package patterns for either MCP73837 or MCP73838
- 1000 mA maximum charge current for AC-Adapter Input Power
- 100 mA (low) and 500 mA (high) for USB-Port Input Power
- $V_{AC}$  provides when both inputs are present at the same time
- Two status LEDs to indicate charge status
- Additional LED to indicate Power-Good ( $\overline{PG}$ ) (Available only for MCP73837)
- Timer Enable ( $\overline{TE}$ ) Test Point to enable/disable safety timer (Available only for MCP73838)
- 2-position Dip Switch for USB charge current control High and Low
- Available THERM pin on the board for temperature monitoring with a thermister

# MCP73837/8 AC/USB Evaluation Board User's Guide

## 2.3 GETTING STARTED

The MCP73837/8 AC/USB Dual Input Battery Charger Evaluation Board is fully assembled and tested for charging a single-cell Li-Ion or Li-Polymer battery with a regulated 5V AC-Adapter or USB-Port.

### 2.3.1 Power Input and Output Connection

#### 2.3.1.1 POWERING THE MCP73837/8 AC/USB DUAL INPUT BATTERY CHARGER EVALUATION BOARD

1. Connect the positive battery terminal to  $V_{BAT+}$  and negative battery terminal to  $V_{BAT-}$ .
2. Connect the DC power supply Negative Terminal to GND.
3. Connect the 5V DC power supply Positive Terminal to  $V_{AC}$  for AC-Adapter Power Source.
4. Connect the DC power supply Negative Terminal to GND.
5. Connect the 5V DC power supply Positive Terminal to  $V_{USB}$  for USB-Port Power Source.
6. It should initiate the battery charging cycle when either power source is present. When both power sources are present, the AC-Adapter Power Source will provide the input power.
7. Position the DIP Switch high for maximum up to 500 mA charge rate and low for maximum up to 100 mA charging rate. Charging current should be able to read off multi-meter that is in series with battery.

**Note:** The battery can be replaced with test circuit or electronic load that can sink current with DC power supply.

8. For MCP73838,  $\overline{TE}$  pull low to enable the internal safety timer while high to disable the internal safety timer.
9. Fast Charge Current can be programmed with various resistors that based on the [Figure 2-1](#).

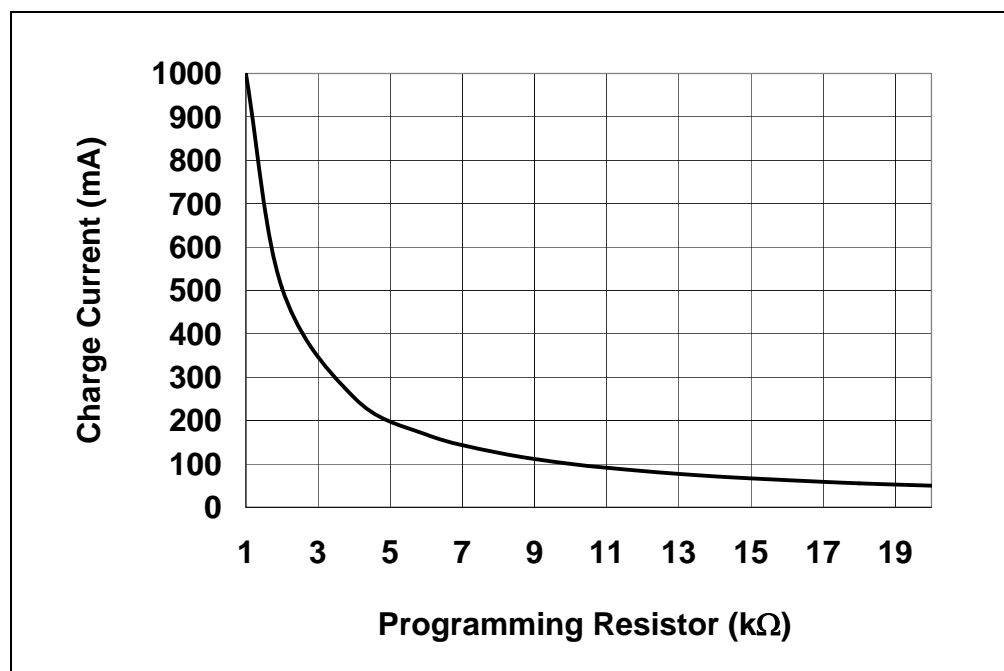

**FIGURE 2-1:** Charge Current ( $I_{OUT}$ ) vs. Programming Resistor ( $R_{PROG}$ ).

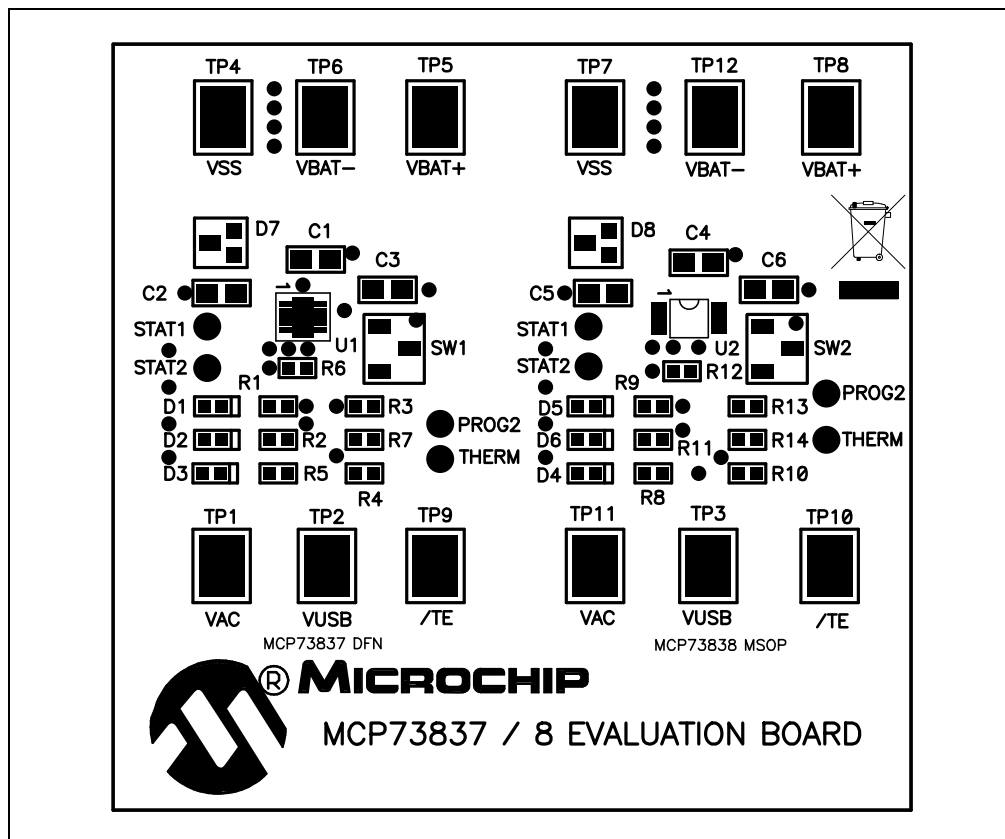

**FIGURE 2-2:** Board Top Assembly.

**TABLE 2-1:** MCP73837/8 CHARGE STATUS OUTPUTS

CHARGE CYCLE STATE	STAT1 GREEN	STAT2 YELLOW	PG RED
Shutdown	Hi-Z	Hi-Z	Hi-Z
Standby	Hi-Z	Hi-Z	L
Precondition	L	Hi-Z	L
Constant Current Fast Charge	L	Hi-Z	L
Constant Voltage	L	Hi-Z	L
Charge Complete - Standby	Hi-Z	L	L
Temperature Fault	Hi-Z	Hi-Z	L
System Test Mode	L	L	L

**Note:** Power-Good (PG) option is only available on MCP73837. The PG option is an open-drain output. The PG is low whenever the input to the MCP73837 is above the UVLO (Undervoltage Lockout) threshold and greater than the battery voltage.

# MCP73837/8 AC/USB Evaluation Board User's Guide

---

NOTES:



# MCP73837/8 AC/USB EVALUATION BOARD USER'S GUIDE

---

---

## Appendix A. Schematic and Layouts

---

---

### NOTICE TO CUSTOMERS

All documentation becomes dated, and this manual is no exception. Microchip tools and documentation are constantly evolving to meet customer needs, so some schematics and board layouts may differ from those in this document. Please refer to our web site ([www.microchip.com](http://www.microchip.com)) to obtain the latest documentation available.

#### A.1 INTRODUCTION

This appendix contains the following schematics and layouts for the MCP73837/8 AC/USB Dual Input Battery Charger Evaluation Board:

- Board – Schematic
- Board – Top Layer
- Board – Top Metal Layer
- Board – Bottom Layer

# MCP73837/8 AC/USB Evaluation Board User's Guide

## A.2 BOARD – SCHEMATIC

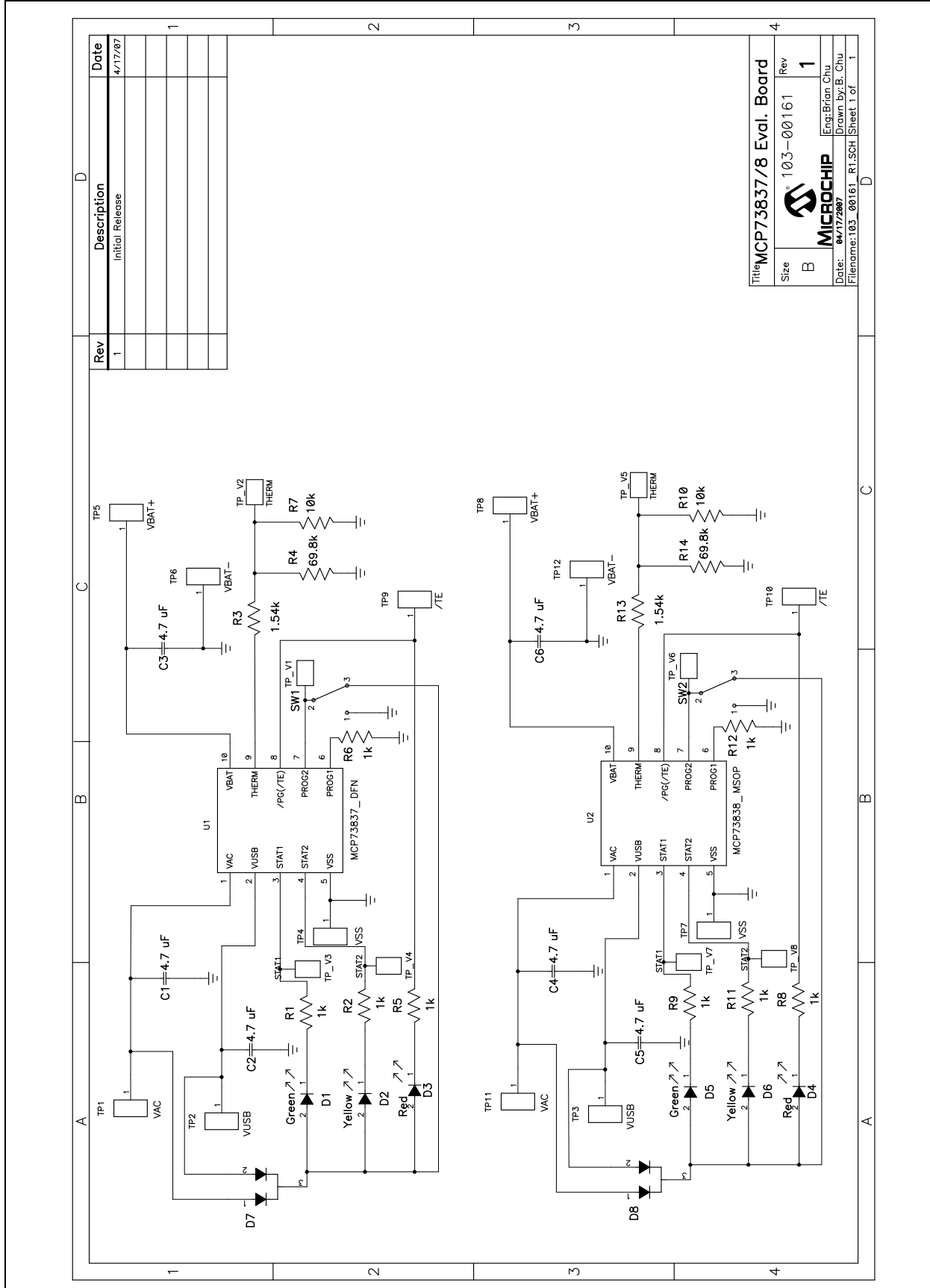



## A.3 BOARD – TOP LAYER

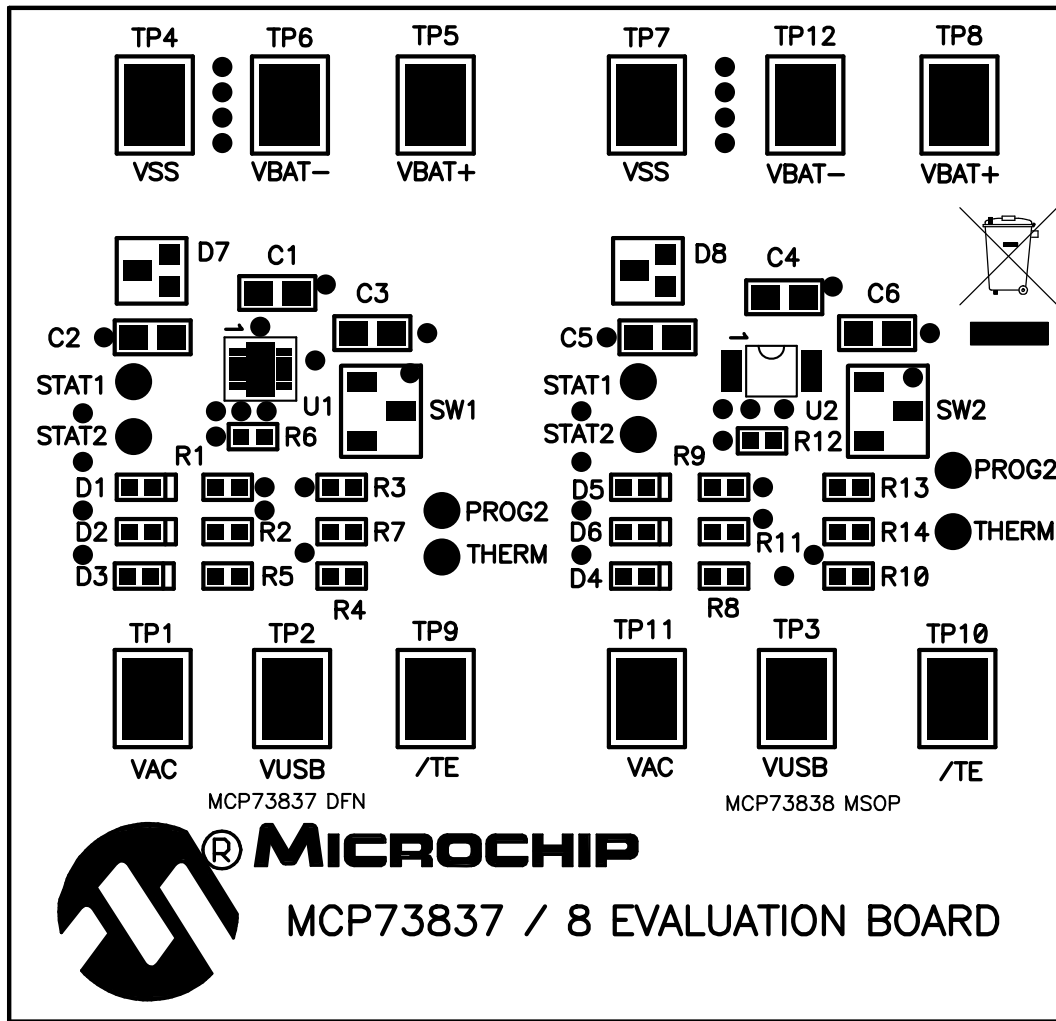

# MCP73837/8 AC/USB Evaluation Board User's Guide

---

## A.4 BOARD – TOP METAL LAYER

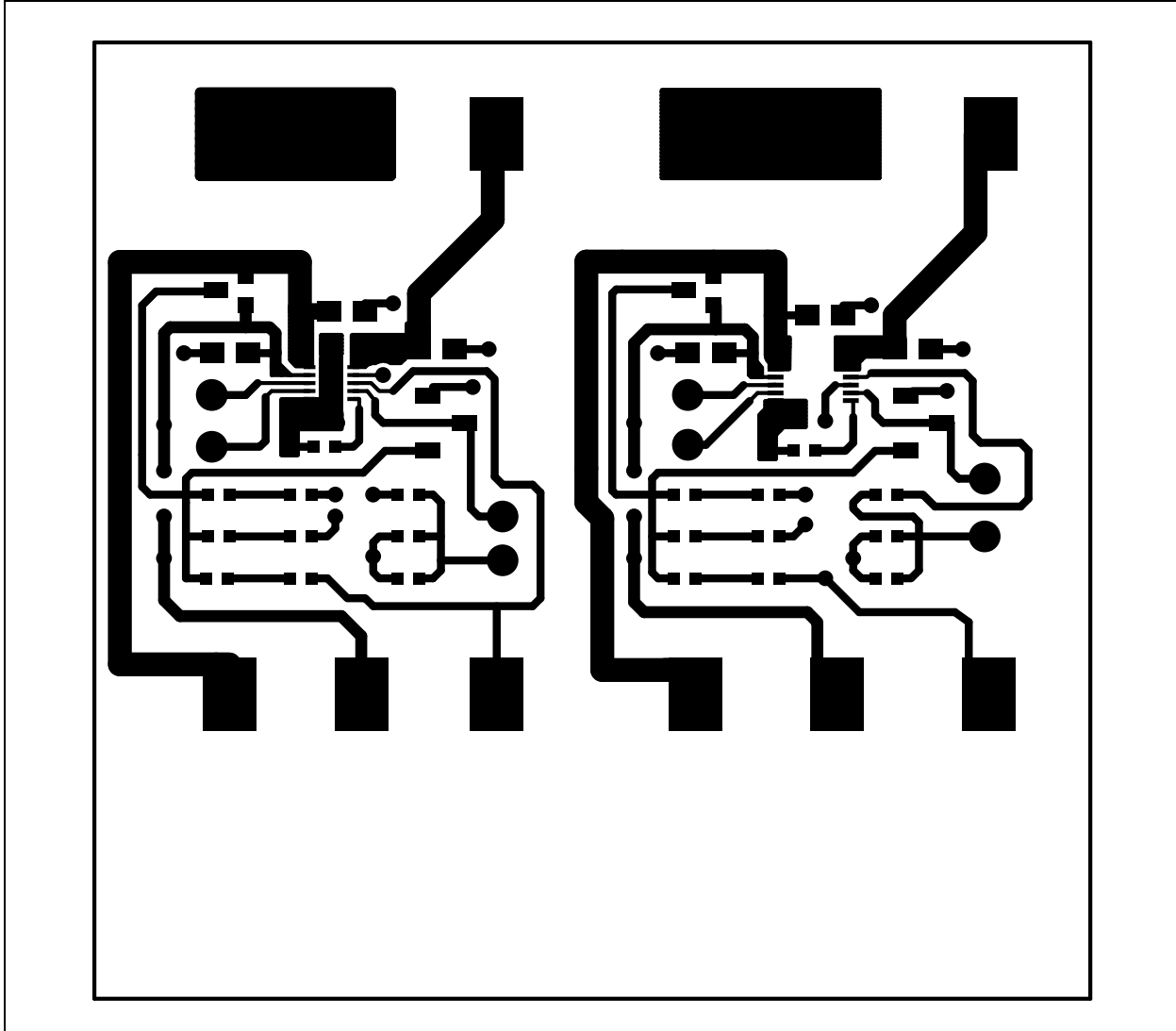

## A.5 BOARD – BOTTOM LAYER

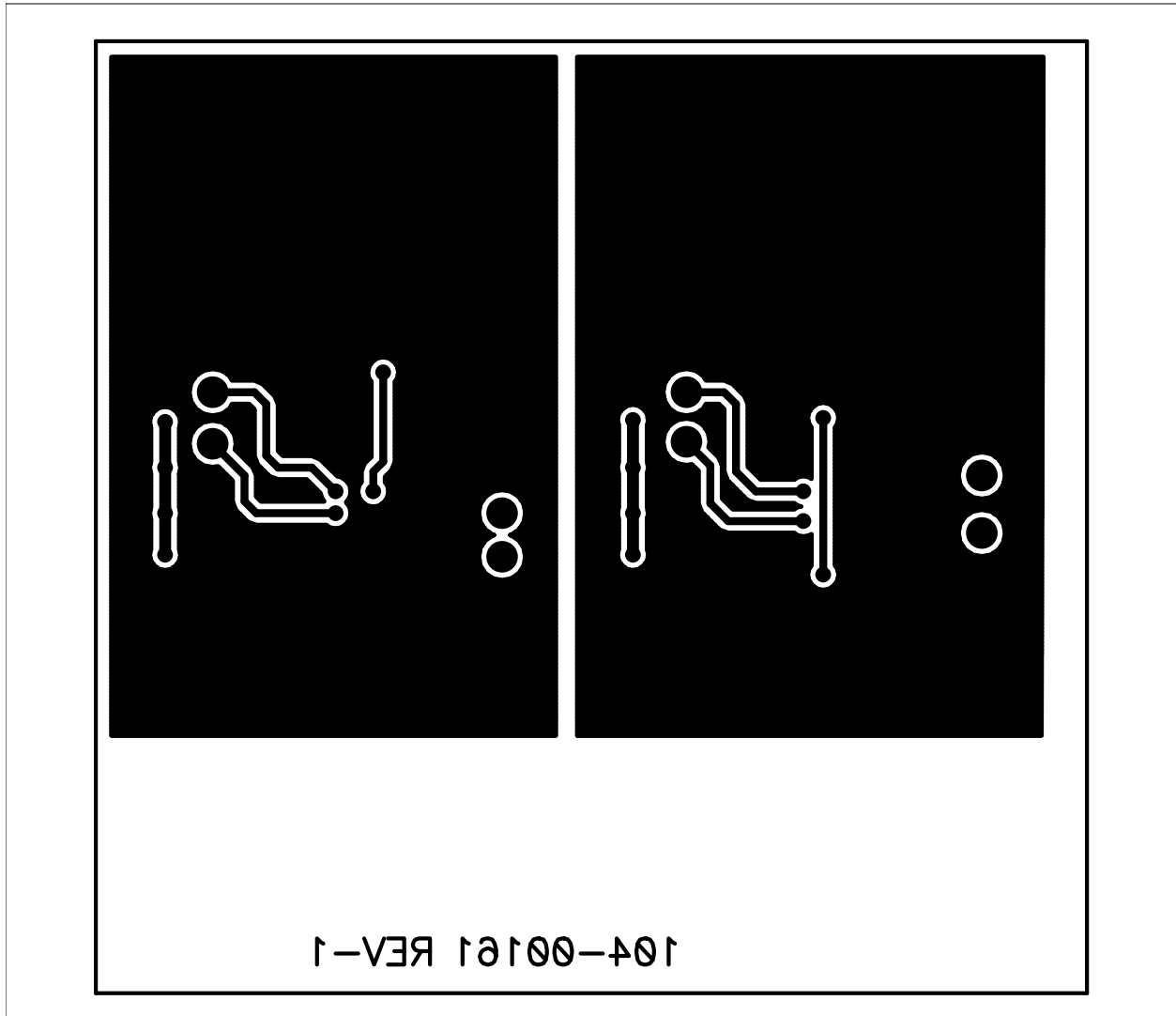

# MCP73837/8 AC/USB Evaluation Board User's Guide

---

NOTES:

**Appendix B. Bill Of Materials (BOM)**

**NOTICE TO CUSTOMERS**

All documentation becomes dated, and this manual is no exception. Microchip tools and documentation are constantly evolving to meet customer needs, so the Bill Of Materials may differ from those in this document. Please refer to our web site ([www.microchip.com](http://www.microchip.com)) to obtain the latest documentation available.

**TABLE B-1: BILL OF MATERIALS (BOM)**

Qty	Reference	Description	Manufacturer	Part Number
4	Bump	BUMPON HEMISPHERE .44X.20 WHITE	3M	SJ5003-9-ND
6	C1, C2, C3, C4, C5, C6	CAP CERAMIC 4.7 $\mu$ F 6.3V X5R 0805	Panasonic® - ECG	ECJ-GVB0J475M
2	D1, D5	LED SUPER GREEN 0603 SMD	Para Light Corp. (USA)	L-C191KGCT-U1
2	D2, D6	LED SUPER YELLOW 0603 SMD	Para Light Corp. (USA)	L-C191KYCT-U1
1	D3	LED SUPER RED CLEAR 0603 SMD	Para Light Corp. (USA)	L-C191KRCT-U1
2	D7, D8	DIODE SWITCH DUAL CC 50V SOT23	On Semiconductor®	BAV74LT1G
1	---	Printed Circuit Board	—	104-00161-R1
8	R1, R2, R5, R6, R8, R9, R11, R12	RES 1K OHM 1/10W 1% 0603 SMD	Panasonic - ECG	ERJ-3EKF1001V
2	R3, R13	RES 1.54K OHM 1/10W 1% 0603 SMD	Panasonic - ECG	ERJ-3EKF1541V
2	R4, R14	RES 69.8K OHM 1/10W 1% 0603 SMD	Panasonic - ECG	ERJ-3EKF6982V
2	R7, R10	RES 10K OHM 1/10W 1% 0603 SMD	Panasonic - ECG	ERJ-3EKF1002V
1	SW1, SW2	SWITCH SLIDE SPDT SMD J-LEAD	COPAL ELECTRONICS INC	CJS-1200TA
12	TP1, TP2, TP3, TP4, TP5, TP6, TP7, TP8, TP9, TP10, TP11, TP12	PC Test Point Compact SMT	Keystone Electronics®	5016
1	U1	Single-Chip Linear Li-Ion Battery Charger with Autonomous USB-Port	Microchip Technology, Inc	MCP73837-FC/MF
1	U2	Single-Chip Linear Li-Ion Battery Charger with Autonomous USB-Port	Microchip Technology, Inc	MCP73838-FC/UN

**Note:** The components listed in this Bill of Materials are representative of the PCB assembly. The released BOM used in manufacturing uses all RoHS-compliant components.



---

---

## WORLDWIDE SALES AND SERVICE

---

---

### AMERICAS

**Corporate Office**  
2355 West Chandler Blvd.  
Chandler, AZ 85224-6199  
Tel: 480-792-7200  
Fax: 480-792-7277  
Technical Support:  
<http://support.microchip.com>  
Web Address:  
[www.microchip.com](http://www.microchip.com)

**Atlanta**  
Duluth, GA  
Tel: 678-957-9614  
Fax: 678-957-1455

**Boston**  
Westborough, MA  
Tel: 774-760-0087  
Fax: 774-760-0088

**Chicago**  
Itasca, IL  
Tel: 630-285-0071  
Fax: 630-285-0075

**Dallas**  
Addison, TX  
Tel: 972-818-7423  
Fax: 972-818-2924

**Detroit**  
Farmington Hills, MI  
Tel: 248-538-2250  
Fax: 248-538-2260

**Kokomo**  
Kokomo, IN  
Tel: 765-864-8360  
Fax: 765-864-8387

**Los Angeles**  
Mission Viejo, CA  
Tel: 949-462-9523  
Fax: 949-462-9608

**Santa Clara**  
Santa Clara, CA  
Tel: 408-961-6444  
Fax: 408-961-6445

**Toronto**  
Mississauga, Ontario,  
Canada  
Tel: 905-673-0699  
Fax: 905-673-6509

### ASIA/PACIFIC

**Asia Pacific Office**  
Suites 3707-14, 37th Floor  
Tower 6, The Gateway  
Harbour City, Kowloon  
Hong Kong  
Tel: 852-2401-1200  
Fax: 852-2401-3431

**Australia - Sydney**  
Tel: 61-2-9868-6733  
Fax: 61-2-9868-6755

**China - Beijing**  
Tel: 86-10-8528-2100  
Fax: 86-10-8528-2104

**China - Chengdu**  
Tel: 86-28-8665-5511  
Fax: 86-28-8665-7889

**China - Fuzhou**  
Tel: 86-591-8750-3506  
Fax: 86-591-8750-3521

**China - Hong Kong SAR**  
Tel: 852-2401-1200  
Fax: 852-2401-3431

**China - Nanjing**  
Tel: 86-25-8473-2460  
Fax: 86-25-8473-2470

**China - Qingdao**  
Tel: 86-532-8502-7355  
Fax: 86-532-8502-7205

**China - Shanghai**  
Tel: 86-21-5407-5533  
Fax: 86-21-5407-5066

**China - Shenyang**  
Tel: 86-24-2334-2829  
Fax: 86-24-2334-2393

**China - Shenzhen**  
Tel: 86-755-8203-2660  
Fax: 86-755-8203-1760

**China - Shunde**  
Tel: 86-757-2839-5507  
Fax: 86-757-2839-5571

**China - Wuhan**  
Tel: 86-27-5980-5300  
Fax: 86-27-5980-5118

**China - Xian**  
Tel: 86-29-8833-7252  
Fax: 86-29-8833-7256

### ASIA/PACIFIC

**India - Bangalore**  
Tel: 91-80-4182-8400  
Fax: 91-80-4182-8422

**India - New Delhi**  
Tel: 91-11-4160-8631  
Fax: 91-11-4160-8632

**India - Pune**  
Tel: 91-20-2566-1512  
Fax: 91-20-2566-1513

**Japan - Yokohama**  
Tel: 81-45-471- 6166  
Fax: 81-45-471-6122

**Korea - Daegu**  
Tel: 82-53-744-4301  
Fax: 82-53-744-4302

**Korea - Seoul**  
Tel: 82-2-554-7200  
Fax: 82-2-558-5932 or  
82-2-558-5934

**Malaysia - Kuala Lumpur**  
Tel: 60-3-6201-9857  
Fax: 60-3-6201-9859

**Malaysia - Penang**  
Tel: 60-4-227-8870  
Fax: 60-4-227-4068

**Philippines - Manila**  
Tel: 63-2-634-9065  
Fax: 63-2-634-9069

**Singapore**  
Tel: 65-6334-8870  
Fax: 65-6334-8850

**Taiwan - Hsin Chu**  
Tel: 886-3-572-9526  
Fax: 886-3-572-6459

**Taiwan - Kaohsiung**  
Tel: 886-7-536-4818  
Fax: 886-7-536-4803

**Taiwan - Taipei**  
Tel: 886-2-2500-6610  
Fax: 886-2-2508-0102

**Thailand - Bangkok**  
Tel: 66-2-694-1351  
Fax: 66-2-694-1350

### EUROPE

**Austria - Wels**  
Tel: 43-7242-2244-39  
Fax: 43-7242-2244-393

**Denmark - Copenhagen**  
Tel: 45-4450-2828  
Fax: 45-4485-2829

**France - Paris**  
Tel: 33-1-69-53-63-20  
Fax: 33-1-69-30-90-79

**Germany - Munich**  
Tel: 49-89-627-144-0  
Fax: 49-89-627-144-44

**Italy - Milan**  
Tel: 39-0331-742611  
Fax: 39-0331-466781

**Netherlands - Drunen**  
Tel: 31-416-690399  
Fax: 31-416-690340

**Spain - Madrid**  
Tel: 34-91-708-08-90  
Fax: 34-91-708-08-91

**UK - Wokingham**  
Tel: 44-118-921-5869  
Fax: 44-118-921-5820

10/05/07

Компания «Океан Электроники» предлагает заключение долгосрочных отношений при поставках импортных электронных компонентов на взаимовыгодных условиях!

Наши преимущества:

- Поставка оригинальных импортных электронных компонентов напрямую с производств Америки, Европы и Азии, а так же с крупнейших складов мира;
- Широкая линейка поставок активных и пассивных импортных электронных компонентов (более 30 млн. наименований);
- Поставка сложных, дефицитных, либо снятых с производства позиций;
- Оперативные сроки поставки под заказ (от 5 рабочих дней);
- Экспресс доставка в любую точку России;
- Помощь Конструкторского Отдела и консультации квалифицированных инженеров;
- Техническая поддержка проекта, помощь в подборе аналогов, поставка прототипов;
- Поставка электронных компонентов под контролем ВП;
- Система менеджмента качества сертифицирована по Международному стандарту ISO 9001;
- При необходимости вся продукция военного и аэрокосмического назначения проходит испытания и сертификацию в лаборатории (по согласованию с заказчиком);
- Поставка специализированных компонентов военного и аэрокосмического уровня качества (Xilinx, Altera, Analog Devices, Intersil, Interpoint, Microsemi, Actel, Aeroflex, Peregrine, VPT, Syfer, Eurofarad, Texas Instruments, MS Kennedy, Miteq, Cobham, E2V, MA-COM, Hittite, Mini-Circuits, General Dynamics и др.);

Компания «Океан Электроники» является официальным дистрибьютором и эксклюзивным представителем в России одного из крупнейших производителей разъемов военного и аэрокосмического назначения «JONHON», а так же официальным дистрибьютором и эксклюзивным представителем в России производителя высокотехнологичных и надежных решений для передачи СВЧ сигналов «FORSTAR».



## JONHON

«JONHON» (основан в 1970 г.)

Разъемы специального, военного и аэрокосмического назначения:

(Применяются в военной, авиационной, аэрокосмической, морской, железнодорожной, горно- и нефтедобывающей отраслях промышленности)

«FORSTAR» (основан в 1998 г.)

ВЧ соединители, коаксиальные кабели, кабельные сборки и микроволновые компоненты:

(Применяются в телекоммуникациях гражданского и специального назначения, в средствах связи, РЛС, а так же военной, авиационной и аэрокосмической отраслях промышленности).



Телефон: 8 (812) 309-75-97 (многоканальный)

Факс: 8 (812) 320-03-32

Электронная почта: [ocean@oceanchips.ru](mailto:ocean@oceanchips.ru)

Web: <http://oceanchips.ru/>

Адрес: 198099, г. Санкт-Петербург, ул. Калинина, д. 2, корп. 4, лит. А