

FEATURES

- Temperature measurements require no external components
- Measures temperatures from -55°C to $+125^{\circ}\text{C}$. Fahrenheit equivalent is -67°F to 257°F
- Thermometer accuracy is $\pm 2.0^{\circ}\text{C}$
- Thermometer resolution is configurable from 9 to 12 bits (0.5°C to 0.0625°C resolution)
- Thermostat settings are user definable
- Data is read from/written to via a 2-wire serial interface
- Wide power supply range (2.7V – 5.5V)
- Software compatible with DS75 2-Wire Thermal Watchdog in thermometer mode
- Space-conscious SOT23-5 package with low thermal time constant

PIN ASSIGNMENT

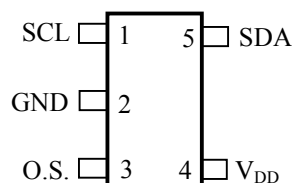

DS1775R
SOT23-5

PIN DESCRIPTION

| | |
|-----------------|---------------------------------|
| GND | Ground |
| SCL | 2-Wire Serial Clock |
| SDA | 2-Wire Serial Data Input/Output |
| V _{DD} | Power Supply Voltage |
| O.S. | Thermostat Output Signal |

DESCRIPTION

The DS1775 SOT23-5 Digital Thermometer and Thermostat provides temperature readings which indicate the temperature of the device. Thermostat settings and temperature readings are all communicated to/from the DS1775 over a simple 2-wire serial interface. No additional components are required; the device is truly a “temperature-to-digital” converter.

For applications that require greater temperature resolution, the user can adjust the readout resolution from 9 to 12 bits. This is particularly useful in applications where thermal runaway conditions must be detected quickly.

The open-drain thermal alarm output, O.S., becomes active when the temperature of the device exceeds a user-defined temperature T_{OS} . The number of consecutive faults required to set O.S. active is configurable by the user. The device can also be configured in the interrupt or comparator mode, to customize the method which clears the fault condition.

As a digital thermometer, the DS1775 is software compatible with the DS75 2-Wire Thermal Watchdog. The DS1775 is assembled in a compact SOT23-5 package allowing for low-cost thermal monitoring/control in space-constrained applications. The low thermal mass allows for time constants previously only possible with thermistors.

Applications for the DS1775 include personal computers/servers/workstations, cellular telephones, office equipment, or any thermally-sensitive system.

ORDERING INFORMATION

| PART | ADDR | MARKING | DESCRIPTION |
|--------------|-------------|-----------------|--|
| DS1775R+T&R | 000 | 7750 (See note) | DS1775R in Lead-Free 5-Pin SOT-23, 3000 Piece Tape-and-Reel |
| DS1775R+U | 000 | 7750 (See note) | DS1775R in Lead-Free 5-Pin SOT-23 |
| DS1775R/T&R | 000 | 7750 | DS1775R in 5-Pin SOT-23, 3000 Piece Tape-and-Reel |
| DS1775R-U | 000 | 7750 | DS1775R in Lead-Free 5-Pin SOT-23 |
| DS1775R1+T&R | 001 | 7751 (See note) | DS1775R1 in Lead-Free 5-Pin SOT-23, 3000 Piece Tape-and-Reel |
| DS1775R1+U | 001 | 7751 (See note) | DS1775R1 in Lead-Free 5-Pin SOT-23 |
| DS1775R1/T&R | 001 | 7751 | DS1775R1 in 5-Pin SOT-23, 3000 Piece Tape-and-Reel |
| DS1775R1-U | 001 | 7751 | DS1775R1 in Lead-Free 5-Pin SOT-23 |
| DS1775R2+T&R | 010 | 7752 (See note) | DS1775R2 in Lead-Free 5-Pin SOT-23, 3000 Piece Tape-and-Reel |
| DS1775R2+U | 010 | 7752 (See note) | DS1775R2 in Lead-Free 5-Pin SOT-23 |
| DS1775R2/T&R | 010 | 7752 | DS1775R2 in 5-Pin SOT-23, 3000 Piece Tape-and-Reel |
| DS1775R2-U | 010 | 7752 | DS1775R2 in Lead-Free 5-Pin SOT-23 |
| DS1775R3+T&R | 011 | 7753 (See note) | DS1775R3 in Lead-Free 5-Pin SOT-23, 3000 Piece Tape-and-Reel |
| DS1775R3+U | 011 | 7753 (See note) | DS1775R3 in Lead-Free 5-Pin SOT-23 |
| DS1775R3/T&R | 011 | 7753 | DS1775R3 in 5-Pin SOT-23, 3000 Piece Tape-and-Reel |
| DS1775R3-U | 011 | 7753 | DS1775R3 in Lead-Free 5-Pin SOT-23 |
| DS1775R4+T&R | 100 | 7754 (See note) | DS1775R4 in Lead-Free 5-Pin SOT-23, 3000 Piece Tape-and-Reel |
| DS1775R4+U | 100 | 7754 (See note) | DS1775R4 in Lead-Free 5-Pin SOT-23 |
| DS1775R4/T&R | 100 | 7754 | DS1775R4 in 5-Pin SOT-23, 3000 Piece Tape-and-Reel |
| DS1775R4-U | 100 | 7754 | DS1775R4 in Lead-Free 5-Pin SOT-23 |
| DS1775R5+T&R | 101 | 7755 (See note) | DS1775R5 in Lead-Free 5-Pin SOT-23, 3000 Piece Tape-and-Reel |
| DS1775R5+U | 101 | 7755 (See note) | DS1775R5 in Lead-Free 5-Pin SOT-23 |
| DS1775R5/T&R | 101 | 7755 | DS1775R5 in 5-Pin SOT-23, 3000 Piece Tape-and-Reel |
| DS1775R5-U | 101 | 7755 | DS1775R5 in Lead-Free 5-Pin SOT-23 |
| DS1775R6+T&R | 110 | 7756 (See note) | DS1775R6 in Lead-Free 5-Pin SOT-23, 3000 Piece Tape-and-Reel |
| DS1775R6+U | 110 | 7756 (See note) | DS1775R6 in Lead-Free 5-Pin SOT-23 |
| DS1775R6/T&R | 110 | 7756 | DS1775R6 in 5-Pin SOT-23, 3000 Piece Tape-and-Reel |
| DS1775R6-U | 110 | 7756 | DS1775R6 in Lead-Free 5-Pin SOT-23 |
| DS1775R7+T&R | 111 | 7757 (See note) | DS1775R7 in Lead-Free 5-Pin SOT-23, 3000 Piece Tape-and-Reel |
| DS1775R7+U | 111 | 7757 (See note) | DS1775R7 in Lead-Free 5-Pin SOT-23 |
| DS1775R7/T&R | 111 | 7757 | DS1775R7 in 5-Pin SOT-23, 3000 Piece Tape-and-Reel |
| DS1775R7-U | 111 | 7757 | DS1775R7 in Lead-Free 5-Pin SOT-23 |

Note: A “+” will also be marked on the package.

DETAILED PIN DESCRIPTION Table 1

| PIN | SYMBOL | DESCRIPTION |
|-------|----------|---|
| PIN 1 | SCL | Clock input/output pin for 2-wire serial communication port. This input should be tied to GND for standalone thermostat operation. |
| PIN 2 | GND | Ground pin. |
| PIN 3 | O.S. | Thermostat output Open-drain output becomes active when temperature exceeds T_{OS} . Device configuration defines means to clear over-temperature state. |
| PIN 4 | V_{DD} | Supply Voltage 2.7V – 5.5V input power pin. |
| PIN 5 | SDA | Data input/output pin for 2-wire serial communication port. In the standalone thermostat mode, this input selects hysteresis. |

OVERVIEW

A block diagram of the DS1775 is shown in Figure 1. The DS1775 consists of five major components:

1. Precision temperature sensor
2. Analog-to-digital converter
3. 2-wire interface electronics
4. Data registers
5. Thermostat comparator

The factory-calibrated temperature sensor requires no external components. Upon power-up, the DS1775 begins temperature conversions with the default resolution of 9 bits (0.5°C resolution). The host can periodically read the value in the temperature register, which contains the last completed conversion. As conversions are performed in the background, reading the temperature register does not affect the conversion in progress.

In power-sensitive applications the user can put the DS1775 into a shutdown mode, under which the sensor will complete and store the conversion in progress and revert to a low-power standby state. In applications where small incremental temperature changes are critical, the user can change the conversion resolution from 9 bits to 10, 11, or 12. Each additional bit of resolution approximately doubles the conversion time. This is accomplished by programming the configuration register. The configuration register defines the conversion state, thermometer resolution/conversion time, active state of the thermostat output, number of consecutive faults to trigger an alarm condition, and the method to terminate an alarm condition.

The user can also program over-temperature (T_{OS}) and under-temperature (T_{HYST}) setpoints for thermostatic operation. The power-up state of T_{OS} is 80°C and that for T_{HYST} is 75°C. The result of each temperature conversion is compared with the T_{OS} and T_{HYST} setpoints. The DS1775 offers two modes for temperature control, the comparator mode and the interrupt mode. This allows the user the flexibility to customize the condition that would generate and clear a fault condition. Regardless of the mode chosen, the O.S. output will become active only after the measured temperature exceeds the respective trippoint a consecutive number of times; the number of consecutive conversions beyond the limit to generate an O.S. is programmable. The power-up state of the DS1775 is in the comparator mode with a single fault generating an active O.S.

Digital data is written to/read from the DS1775 via a 2-wire interface, and all communication is MSb first.

DS1775 FUNCTIONAL BLOCK DIAGRAM Figure 1

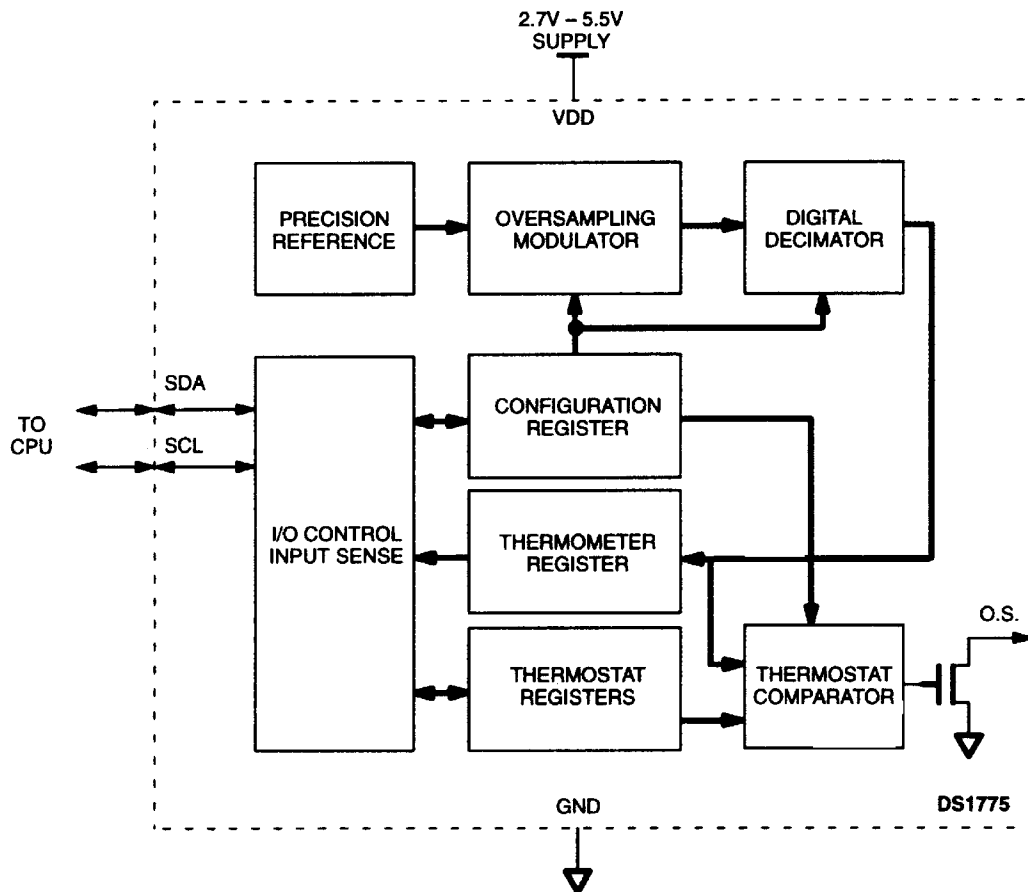

OPERATION—Measuring Temperature

The core of DS1775 functionality is its direct-to-digital temperature sensor. The DS1775 measures temperature through the use of an on-chip temperature measurement technique with an operating range from -55°C to $+125^{\circ}\text{C}$. Temperature conversions are initiated upon power-up, and the most recent result is stored in the thermometer register. Conversions are performed continuously unless the user intervenes by altering the configuration register to put the DS1775 into a shutdown mode. Regardless of the mode used, the digital temperature can be retrieved from the temperature register by setting the pointer to that location (00h, power-up default). The DS1775 power-up default has the sensor automatically performing 9-bit conversions continuously. Details on how to change the settings after power-up are contained in the “OPERATION—Programming” section.

The resolution of the temperature conversion is configurable (9, 10, 11, or 12 bits), with 9-bit readings the default state. This equates to a temperature resolution of 0.5°C , 0.25°C , 0.125°C , or 0.0625°C . Following each conversion, thermal data is stored in the thermometer register in two's complement format; the information can be retrieved over the 2-wire interface with the device pointer set to the temperature register. Table 2 describes the exact relationship of output data to measured temperature. The table assumes the DS1775 is configured for 12-bit resolution; if the device is configured in a lower resolution mode, those bits will contain zeros. The data is transmitted serially over the 2-wire serial interface, MSb first. The MSb of the temperature register contains the “sign” (S) bit, denoting whether the temperature is positive or negative. For Fahrenheit usage, a lookup table or conversion routine must be used.

Temperature/Data Relationships Table 2

| | | | | | | | | |
|----------|----------|-------------|----------|-------|-------|-------|-------|-----|
| S | 2^6 | 2^5 | 2^4 | 2^3 | 2^2 | 2^1 | 2^0 | MSB |
| MSb | | (UNIT = °C) | | | | LSb | | |
| 2^{-1} | 2^{-2} | 2^{-3} | 2^{-4} | 0 | 0 | 0 | 0 | LSB |

| TEMP | DIGITAL OUTPUT (Binary) | DIGITAL OUTPUT (Hex) |
|------------|----------------------------|----------------------|
| +125°C | 0111 1101 0000 0000 | 7D00h |
| +25.0625°C | 0000 1010 0010 0000 | 1910h |
| +10.125°C | 0000 1010 0010 0000 | 0A20h |
| +0.5°C | 0000 0000 1000 0000 | 0080h |
| +0°C | 0000 0000 0000 0000 | 0000h |
| -0.5°C | 1111 1111 1000 0000 | FF80h |
| -10.125°C | 1111 0101 1110 0000 | F5E0h |
| -25.0625°C | 1110 0110 1111 0000 | E6F0h |
| -55°C | 1100 1001 0000 0000 | C900h |

OPERATION—Thermostat Control

In its comparator operating mode, the DS1775 functions as a thermostat with programmable hysteresis, as shown in Figure 2. When the DS1775's temperature meets or exceeds the value stored in the high temperature trip register (T_{OS}) a consecutive number of times, as defined by the configuration register, the output becomes active and stays active until the first time that the temperature falls below the temperature stored in the low temperature trigger register (T_{HYST}). In this way, any amount of hysteresis may be obtained. The DS1775 powers up in the comparator mode with $T_{OS}=80^{\circ}\text{C}$ and $T_{HYST}=75^{\circ}\text{C}$ and can be used as a standalone thermostat (no 2-wire interface required) with those setpoints.

In the interrupt mode, the O.S. output will first become active following the programmed number of consecutive conversions above T_{OS} . The fault can only be cleared by either setting the DS1775 in a shutdown mode or by reading any register (temperature, configuration, T_{OS} , or T_{HYST}) on the device. Following a clear, a subsequent fault can only occur if consecutive conversions fall below T_{HYST} . This interrupt/clear process is thus cyclical (T_{OS} , clear, T_{HYST} , clear, T_{OS} , clear, T_{HYST} , clear, ...). Only the first of multiple consecutive T_{OS} violations will activate O.S., even if each fault is separated by a clearing function. The same situation applies to multiple consecutive T_{HYST} events.

O.S. OUTPUT TRANSFER FUNCTION Figure 2

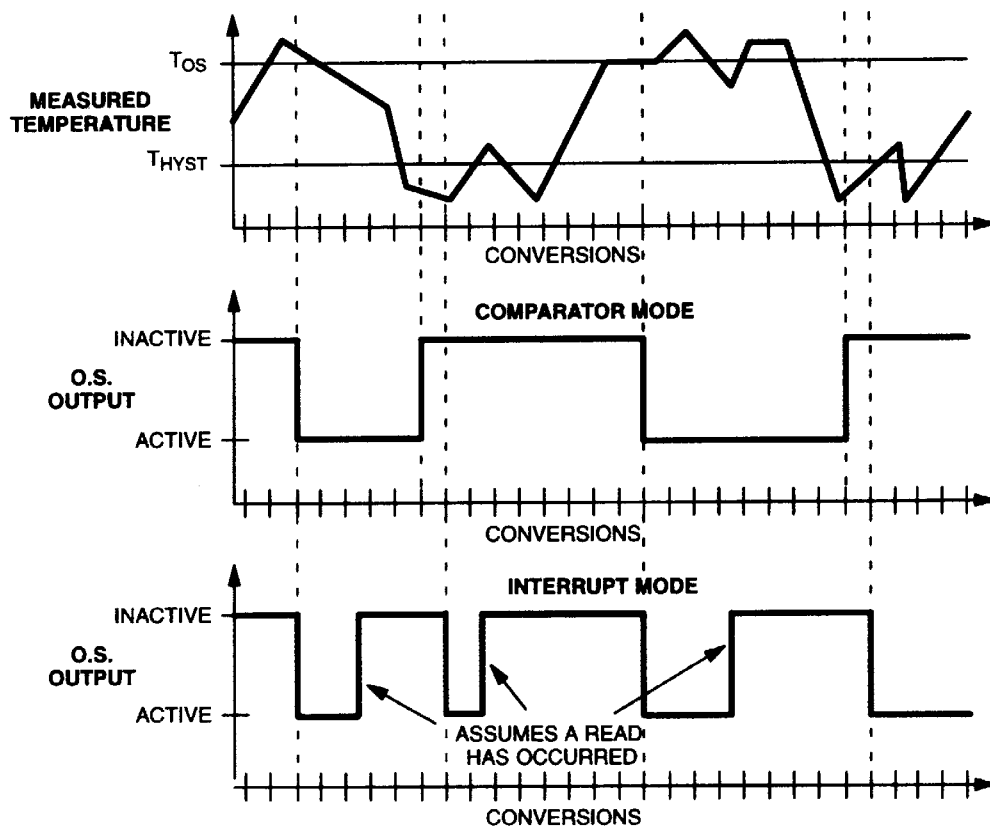

THIS TRANSFER FUNCTION ASSUMES THE DS1775 IS CONFIGURED SUCH THAT 2 CONSECUTIVE CONVERSIONS OUT OF TOLERANCE CONSTITUTE AN O.S. FAULT.

Regardless of the mode chosen, the O.S. output is open-drain and the active state is set in the configuration register. The power-up default is active low. Refer to the “OPERATION–Programming” section for instructions in adjusting the thermostat setpoints, thermostat mode, and O.S. active state.

OPERATION–Programming

There are three areas of interest in programming the DS1775: the configuration register, the T_{OS} register, and the T_{HYST} register. All programming is done via the 2-wire interface by setting the pointer to the appropriate location. Table 3 illustrates the pointer settings for the four registers of the DS1775.

Pointer Register Structure Table 3

| POINTER | ACTIVE REGISTER |
|---------|-----------------------|
| 00h | Temperature (default) |
| 01h | Configuration |
| 02h | T_{HYST} |
| 03h | T_{OS} |

The DS1775 will power up with the temperature register selected. If the host wishes to change the data pointer it simply addresses the DS1775 in the write mode ($R/\bar{W}=0$), receives an acknowledge, and writes the 8 bits that correspond to the new desired location. The last pointer location is always maintained so that consecutive reads from the same register do not require the host to always provide a pointer address. The only exception is at power-up, in which case the pointer will always be set to 00h, the temperature

register. The pointer address must always proceed data in writing to a register, regardless of which address is currently selected. Please refer to the “2–Wire Serial Data Bus” section for details of the 2–wire bus protocol.

Configuration Register Programming

The configuration register is accessed if the DS1775 pointer is currently set to the 01h location. Writing to or reading from the register is determined by the R/W bit of the 2–wire control byte (See “2–wire Serial Data Bus” section). Data is read from or written to the configuration register MSb first. The format of the register is illustrated below in Figure 3. The effect each bit has on DS1775 functionality is described below along with the power–up state of the bit. The user has read/write access to all bits in the configuration register. The entire register is volatile, and thus it will power–up in the default state.

Configuration/Status Register Figure 3

| | | | | | | | |
|-----|----|----|----|----|-----|----|-----|
| 0 | R1 | R0 | F1 | F0 | POL | TM | SD |
| MSb | | | | | | | LSb |

SD = Shutdown bit. If SD is “0”, the DS1775 will continuously perform temperature conversions and store the last completed result in the thermometer register. If SD is changed to “1”, the conversion in progress will be completed and stored; then the device will revert to a low–power standby mode. The O.S. output will be cleared if the device is in the interrupt mode and remain unchanged in the comparator mode. The 2–wire port remains active. The power–up default state is “0” (continuous conversion mode).

TM = Thermostat mode. If TM=“0”, the DS1775 is in the comparator mode. TM=“1” sets the device to the interrupt mode. See “OPERATION–Thermostat Control” section for a description of the difference between the two modes. The power–up default state of the TM bit is “0” (comparator mode).

POL = O.S. Polarity Bit. If POL = “1”, the active state of the O.S. output will be high. A “0” stored in this location sets the thermostat output to an active low state. The user has read/write access to the POL bit, and the power–up default state is “0” (active low).

F0, F1 = O.S. Fault Tolerance bits. The fault tolerance defines the number of consecutive conversions returning a temperature beyond limits is required to set the O.S. output in an active state. This may be necessary to add margin in noisy environments. Table 4 below defines the four settings. The DS1775 will power up with F0=F1=“0”, such that a single occurrence will trigger a fault.

Fault Tolerance Configuration Table 4

| F1 | F0 | Consecutive conversions beyond limits to generate fault |
|----|----|---|
| 0 | 0 | 1 |
| 0 | 1 | 2 |
| 1 | 0 | 4 |
| 1 | 1 | 6 |

R0, R1 = Thermometer resolution bits. Table 5 defines the resolution of the digital thermometer, based on the settings of these two bits. There is a direct trade–off between resolution and conversion time, as depicted in the AC Electrical Characteristics. The default state is R0=“0” and R1=“0” (9–bit conversions).

Thermometer Resolution Configuration Table 5

| R1 | R0 | Thermometer Resolution | Max Conversion Time |
|----|----|------------------------|---------------------|
| 0 | 0 | 9-bit | 0.1875s |
| 0 | 1 | 10-bit | 0.375s |
| 1 | 0 | 11-bit | 0.75s |
| 1 | 1 | 12-bit | 1.5s |

Thermostat Setpoints Programming

The thermostat registers (T_{OS} and T_{HYST}) can be programmed or read via the 2-wire interface. T_{OS} is accessed by setting the DS1775 data pointer to the 03h location, and to the 02h location for T_{HYST} .

The format of the T_{OS} and T_{HYST} registers is identical to that of the Thermometer register; that is, 12-bit 2's complement representation of the temperature in °C. The user can program the number of bits (9, 10, 11, or 12) for each T_{OS} and T_{HYST} that corresponds to the thermometer resolution mode chosen. For example, if the 9-bit mode is chosen the 3 least significant bits of T_{OS} and T_{HYST} will be ignored by the thermostat comparator. The format for both T_{OS} and T_{HYST} is shown in Table 6. The power-up default for T_{OS} is 80°C and for T_{HYST} is 75°C.

Thermostat Setpoint (T_{OS}/T_{HYST}) Format Table 6

| | | | | | | | | |
|----------|-------------|----------|----------|-------|-------|-------|-------|-----|
| S | 2^6 | 2^5 | 2^4 | 2^3 | 2^2 | 2^1 | 2^0 | MSB |
| MSb | (UNIT = °C) | | | | | | LSb | |
| 2^{-1} | 2^{-2} | 2^{-3} | 2^{-4} | 0 | 0 | 0 | 0 | LSB |

TEMPERATURE/DATA RELATIONSHIPS

| TEMP | DIGITAL OUTPUT (Binary) | DIGITAL OUTPUT (Hex) |
|------------|----------------------------|----------------------|
| +80°C | 0101 0000 0000 0000 | 5000h |
| +75°C | 0100 1011 0000 0000 | 4B00h |
| +10.125°C | 0000 1010 0010 0000 | 0A20h |
| +0.5°C | 0000 0000 1000 0000 | 0080h |
| +0°C | 0000 0000 0000 0000 | 0000h |
| -0.5°C | 1111 1111 1000 0000 | FF80h |
| -10.125°C | 1111 0101 1110 0000 | F5E0h |
| -25.0625°C | 1110 0110 1111 0000 | E6F0h |
| -55°C | 1100 1001 0000 0000 | C900h |

If the user does not wish to take advantage of the thermostat capabilities of the DS1775, the 24 bits can be used for general storage of system data that need not be maintained following a power loss.

2-WIRE SERIAL DATA BUS

The DS1775 supports a bi-directional 2-wire bus and data transmission protocol. A device that sends data onto the bus is defined as a transmitter, and a device receiving data as a receiver. The device that controls the message is called a “master”. The devices that are controlled by the master are “slaves”. The bus must be controlled by a master device which generates the serial clock (SCL), controls the bus access, and generates the START and STOP conditions. The DS1775 operates as a slave on the two-wire bus. Connections to the bus are made via the open-drain I/O lines SDA and SCL.

The following bus protocol has been defined (See Figure 4):

- Data transfer may be initiated only when the bus is not busy.
- During data transfer, the data line must remain stable whenever the clock line is HIGH. Changes in the data line while the clock line is high will be interpreted as control signals.

Accordingly, the following bus conditions have been defined:

Bus not busy: Both data and clock lines remain HIGH.

Start data transfer: A change in the state of the data line, from HIGH to LOW, while the clock is HIGH, defines a START condition.

Stop data transfer: A change in the state of the data line, from LOW to HIGH, while the clock line is HIGH, defines the STOP condition.

Data valid: The state of the data line represents valid data when, after a START condition, the data line is stable for the duration of the HIGH period of the clock signal. The data on the line must be changed during the LOW period of the clock signal. There is one clock pulse per bit of data.

Each data transfer is initiated with a START condition and terminated with a STOP condition. The number of data bytes transferred between START and STOP conditions is not limited, and is determined by the master device. The information is transferred byte-wise and each receiver acknowledges with a ninth bit.

Within the bus specifications a regular mode (100kHz clock rate) and a fast mode (400kHz clock rate) are defined. The DS1775 works in both modes.

Acknowledge: Each receiving device, when addressed, is obliged to generate an acknowledge after the reception of each byte. The master device must generate an extra clock pulse which is associated with this acknowledge bit.

A device that acknowledges must pull down the SDA line during the acknowledge clock pulse in such a way that the SDA line is stable LOW during the HIGH period of the acknowledge related clock pulse. Of course, setup and hold times must be taken into account. A master must signal an end of data to the slave by not generating an acknowledge bit on the last byte that has been clocked out of the slave. In this case, the slave must leave the data line HIGH to enable the master to generate the STOP condition.

DATA TRANSFER ON 2-WIRE SERIAL BUS Figure 4

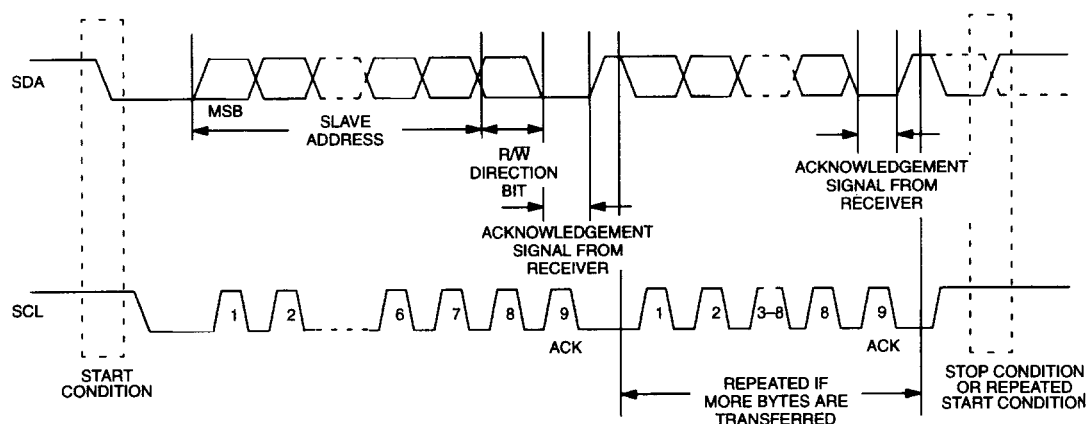

Figure 5 details how data transfer is accomplished on the two-wire bus. Depending upon the state of the R/W bit, two types of data transfer are possible:

1. **Data transfer from a master transmitter to a slave receiver.** The first byte transmitted by the master is the slave address. Next follows a number of data bytes. The slave returns an acknowledge bit after each received byte.
2. **Data transfer from a slave transmitter to a master receiver.** The first byte (the slave address) is transmitted by the master. The slave then returns an acknowledge bit. Next follows a number of data bytes transmitted by the slave to the master. The master returns an acknowledge bit after all received bytes other than the last byte. At the end of the last received byte, a 'not acknowledge' is returned.

The master device generates all of the serial clock pulses and the START and STOP conditions. A transfer is ended with a STOP condition or with a repeated START condition. Since a repeated START condition is also the beginning of the next serial transfer, the bus will not be released.

The DS1775 may operate in the following two modes:

1. **Slave receiver mode:** Serial data and clock are received through SDA and SCL. After each byte is received, an acknowledge bit is transmitted. START and STOP conditions are recognized as the beginning and end of a serial transfer. Address recognition is performed by hardware after reception of the slave address and direction bit.
2. **Slave transmitter mode:** The first byte is received and handled as in the slave receiver mode. However, in this mode, the direction bit will indicate that the transfer direction is reversed. Serial data is transmitted on SDA by the DS1775 while the serial clock is input on SCL. START and STOP conditions are recognized as the beginning and end of a serial transfer.

SLAVE ADDRESS

A control byte is the first byte received following the START condition from the master device. The control byte consists of a four bit control code; for the DS1775, this is set as 1001 binary for read and write operations. The next three bits of the control byte are the device select bits (A2, A1, A0). These bits are set to 000 (A2="0", A1="0", A0="0") for the DS1775R/TRL and vary according to the device's part number as specified in the "Ordering Information" section. They are used by the master device to select which of eight devices are to be accessed. The set bits are in effect the three least significant bits of the slave address. The last bit of the control byte (R/\bar{w}) defines the operation to be performed. When set to a "1" a read operation is selected, and when set to a "0" a write operation is selected. Following the START condition, the DS1775 monitors the SDA bus checking the device type identifier being transmitted. Upon receiving the 1001 code and appropriate device select bits of 000, the DS1775 outputs an acknowledge signal on the SDA line.

2-WIRE SERIAL COMMUNICATION WITH DS1775 Figure 5

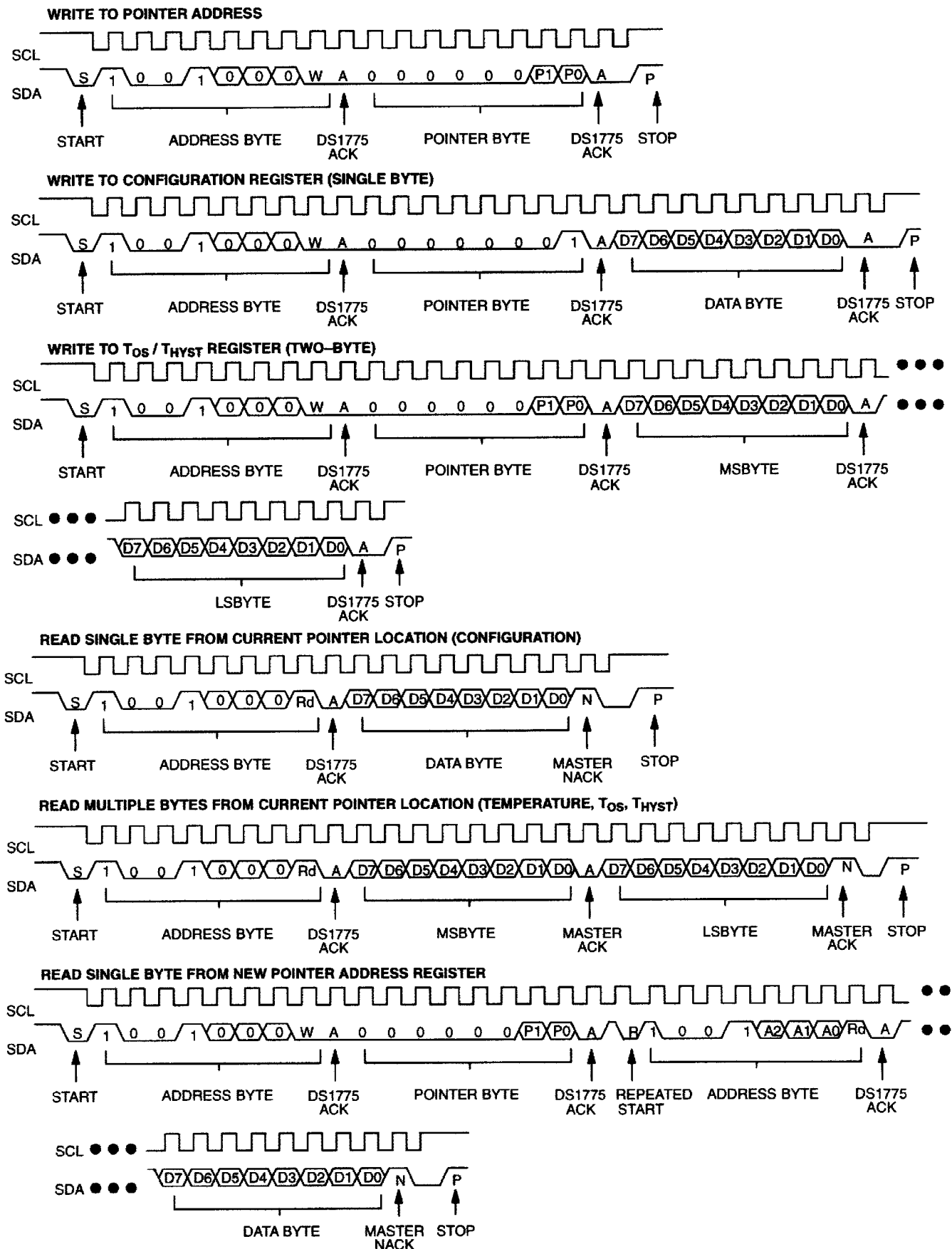

ABSOLUTE MAXIMUM RATINGS*

| | |
|--|------------------------------|
| Voltage on VDD, Relative to Ground | -0.3V to +7.0V |
| Voltage on any other pin, Relative to Ground | -0.3V to +7.0V |
| Operating Temperature | -55°C to +125°C |
| Storage Temperature | -55°C to +125°C |
| Soldering Temperature | See J-STD-020A Specification |

* This is a stress rating only and functional operation of the device at these or any other conditions above those indicated in the operation sections of this specification is not implied. Exposure to absolute maximum rating conditions for extended periods of time may affect reliability.

DC ELECTRICAL CHARACTERISTICS

(-55°C to +125°C; 2.7V ≤ V_{DD} ≤ 5.5V)

| PARAMETER | SYMBOL | CONDITION | MIN | TYP | MAX | UNITS | NOTES |
|------------------------------|------------------|--|---------------------|-----|----------------------|-------|-------|
| Supply Voltage | V _{DD} | | 2.7 | | 5.5 | V | 1 |
| Input Logic High | V _{IH} | | 0.7 V _{DD} | | V _{DD} +0.5 | V | 1 |
| Input Logic Low | V _{IL} | | -0.5 | | 0.3V _{DD} | V | 1 |
| SDA Output Logic Low Voltage | V _{OL1} | 3 mA sink current | 0 | | 0.4 | V | 1 |
| | V _{OL2} | 6 mA sink current | 0 | | 0.6 | | |
| O.S. Saturation Voltage | V _{OL} | 4 mA sink current | | | 0.8 | V | 1,9 |
| Input current each I/O pin | | 0.4 < V _{IO} < 0.9V _{DD} | -10 | | +10 | μA | 2 |
| I/O Capacitance | C _{IO} | | | | 10 | pF | |
| Standby Current | I _{DD1} | | | | 1 | μA | 3,4 |
| Active Current | I _{DD} | Active Temp. Conversions | | | 1000 | μA | 3,4 |
| | | Communication only | | | 100 | | |

ELECTRICAL CHARACTERISTICS:**DIGITAL THERMOMETER**

(-55°C to +125°C; 2.7V ≤ V_{DD} ≤ 5.5V)

| PARAMETER | SYMBOL | CONDITION | MIN | TYP | MAX | UNITS | NOTES |
|-------------------|--------------------|----------------------------------|-----|------|--------------|-------|-------|
| Thermometer Error | T _{ERR} | -10°C to +85°C -55°C to 125°C | | | ±2.0 ±3.0 | °C | 9, 10 |
| Resolution | | | 9 | | 12 | bits | |
| Conversion Time | t _{CONVT} | 9-bit conversion | | 125 | 187.5 | ms | |
| | | 10-bit conversion | | 250 | 375 | | |
| | | 11-bit conversion | | 500 | 750 | | |
| | | 12-bit conversion | | 1000 | 1500 | | |

AC ELECTRICAL CHARACTERISTICS:**2-WIRE INTERFACE**(-55°C to +125°C; $V_{DD} = 2.7V$ to 5.5V)

| PARAMETER | SYMBOL | CONDITION | MIN | TYP | MAX | UNITS | NOTES |
|--|----------------|----------------------------|--------------------------|-----|-------------|---------|-------|
| SCL clock frequency | f_{SCL} | Fast Mode Standard Mode | | | 400 100 | KHZ | |
| Bus free time between a STOP and START condition | t_{BUF} | Fast Mode Standard Mode | 1.3 4.7 | | | μs | |
| Hold time (repeated) START condition | $t_{HD:STA}$ | Fast Mode Standard Mode | 0.6 4.0 | | | μs | 5 |
| LOW period of SCL | t_{LOW} | Fast Mode Standard Mode | 1.3 4.7 | | | μs | |
| HIGH period of SCL | t_{HIGH} | Fast Mode Standard Mode | 0.6 4.0 | | | μs | |
| Set-up time for a repeated START | $t_{SU:STA}$ | Fast Mode Standard Mode | 0.6 4.7 | | | μs | |
| Data hold time | $t_{HD:DAT}$ | Fast Mode Standard Mode | 0 0 | | 0.9 0.9 | μs | 6 |
| Data set-up time | $t_{SU:DAT}$ | Fast Mode Standard Mode | 100 250 | | | ns | 7 |
| Rise time of both SDA and SCL signals | t_R | Fast Mode Standard Mode | 20+ 0.1C _B | | 300 1000 | ns | 8 |
| Fall time of both SDA and SCL signals | t_F | Fast Mode Standard Mode | 20+ 0.1C _B | | 300 300 | ns | 8 |
| Set-up time for STOP | $t_{SU:STO}$ | Fast Mode Standard Mode | 0.6 4.0 | | | μs | |
| Capacitive load for each bus line | C _b | | | | 400 | pF | 8 |
| Input Capacitance | C _I | | | 5 | | pF | |

NOTES:

- All voltages are referenced to ground.
- I/O pins of fast mode devices must not obstruct the SDA and SCL lines if V_{DD} is switched off.
- I_{DD} specified with O.S. pin open.
- I_{DD} specified with V_{DD} at 5.0V and SDA, SCL = 5.0V, 0°C to +70°C.
- After this period, the first clock pulse is generated.
- The maximum $t_{HD:DAT}$ has only to be met if the device does not stretch the LOW period (t_{LOW}) of the SCL signal.
- A fast mode device can be used in a standard mode system, but the requirement $t_{SU:DAT} \geq 250$ ns must then be met. This will automatically be the case if the device does not stretch the LOW period of the SCL signal. If such a device does stretch the LOW period of the SCL signal, it must output the next data bit to the SDA line $t_{RMAX} + t_{SU:DAT} = 1000 + 250 = 1250$ ns before the SCL line is released.
- C_b – total capacitance of one bus line in pF.
- Internal heating caused by O.S. loading will cause the DS1775 to read approximately 0.5°C higher if O.S. is sinking the max rated current.
- Contact the factory in Dallas, (972) 371-4448, for operation requiring temperature readings greater than 120°C.

TIMING DIAGRAMS Figure 6

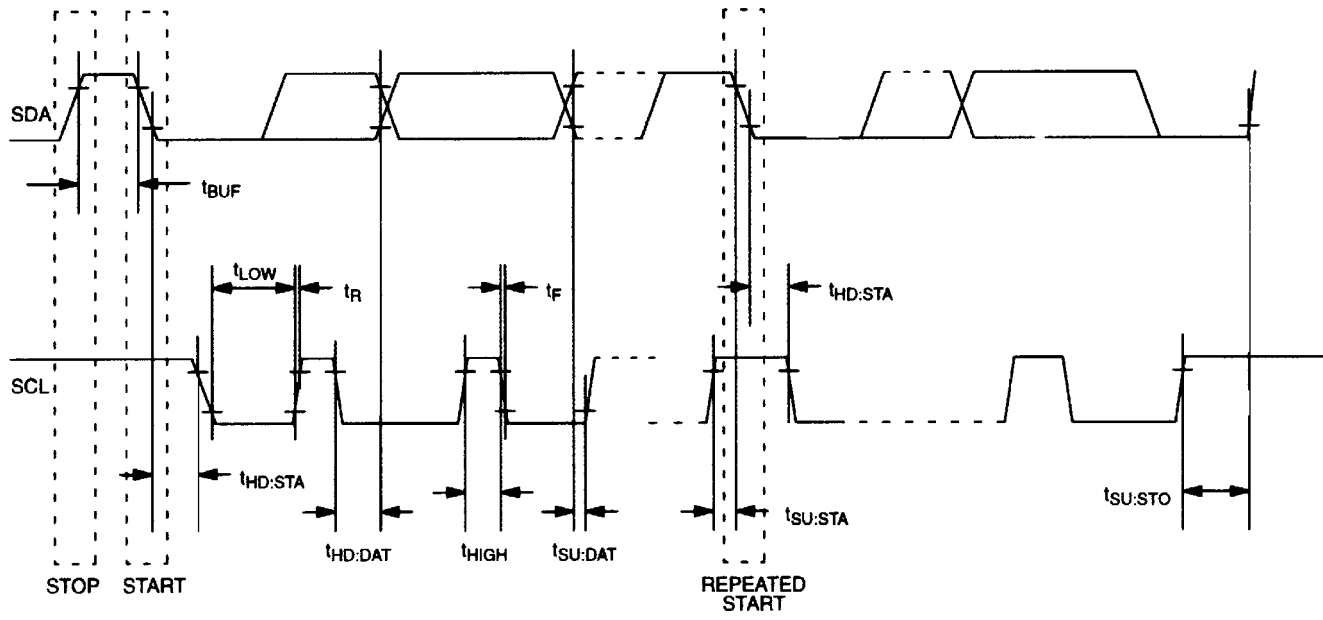

Компания «Океан Электроники» предлагает заключение долгосрочных отношений при поставках импортных электронных компонентов на взаимовыгодных условиях!

Наши преимущества:

- Поставка оригинальных импортных электронных компонентов напрямую с производств Америки, Европы и Азии, а так же с крупнейших складов мира;
- Широкая линейка поставок активных и пассивных импортных электронных компонентов (более 30 млн. наименований);
- Поставка сложных, дефицитных, либо снятых с производства позиций;
- Оперативные сроки поставки под заказ (от 5 рабочих дней);
- Экспресс доставка в любую точку России;
- Помощь Конструкторского Отдела и консультации квалифицированных инженеров;
- Техническая поддержка проекта, помощь в подборе аналогов, поставка прототипов;
- Поставка электронных компонентов под контролем ВП;
- Система менеджмента качества сертифицирована по Международному стандарту ISO 9001;
- При необходимости вся продукция военного и аэрокосмического назначения проходит испытания и сертификацию в лаборатории (по согласованию с заказчиком);
- Поставка специализированных компонентов военного и аэрокосмического уровня качества (Xilinx, Altera, Analog Devices, Intersil, Interpoint, Microsemi, Actel, Aeroflex, Peregrine, VPT, Syfer, Eurofarad, Texas Instruments, MS Kennedy, Miteq, Cobham, E2V, MA-COM, Hittite, Mini-Circuits, General Dynamics и др.);

Компания «Океан Электроники» является официальным дистрибьютором и эксклюзивным представителем в России одного из крупнейших производителей разъемов военного и аэрокосмического назначения «JONHON», а так же официальным дистрибьютором и эксклюзивным представителем в России производителя высокотехнологичных и надежных решений для передачи СВЧ сигналов «FORSTAR».



JONHON

«JONHON» (основан в 1970 г.)

Разъемы специального, военного и аэрокосмического назначения:

(Применяются в военной, авиационной, аэрокосмической, морской, железнодорожной, горно- и нефтедобывающей отраслях промышленности)

«FORSTAR» (основан в 1998 г.)

ВЧ соединители, коаксиальные кабели, кабельные сборки и микроволновые компоненты:

(Применяются в телекоммуникациях гражданского и специального назначения, в средствах связи, РЛС, а так же военной, авиационной и аэрокосмической отраслях промышленности).



Телефон: 8 (812) 309-75-97 (многоканальный)

Факс: 8 (812) 320-03-32

Электронная почта: ocean@oceanchips.ru

Web: <http://oceanchips.ru/>

Адрес: 198099, г. Санкт-Петербург, ул. Калинина, д. 2, корп. 4, лит. А