

650V, 280mΩ, 11.6A N-Channel Enhancement Mode Super Junction Power MOSFET

Ordering Information

Part Number	Package Option
D3S280N65B-U	TO-220
D3S280N65E-U	TO-263

Description

+FET[™] is an advanced Super Junction Power MOSFET offering excellent efficiency through low R_{DS-ON} and low gate charge. +FET[™] is a rugged device with precision charge balance implementation designed for demanding uses such as enterprise power computing power supplies, motor control, lighting and other challenging power conversion applications.

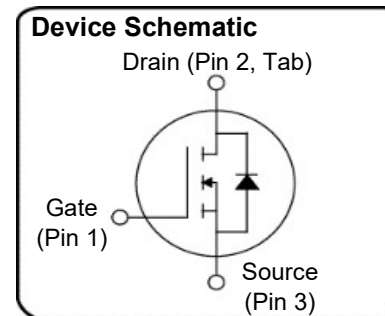
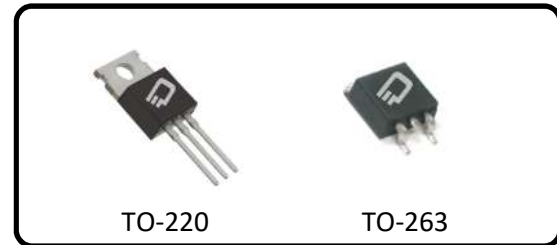

Features

- LOW $R_{DS(ON)}$
- FAST SWITCHING
- HIGH E_{AS}
- REL TEST SPEC: JESD-22
- HTRB >3000 HRS

Benefits

- LOW CONDUCTION LOSSES
- HIGH EFFICIENCY
- EXCELLENT AVALANCHE PERFORMANCE

Table 1 Key Parameters

Parameter	Value	Unit
V_{DSS} @ T_{jmax}	710	V
$R_{DS(on)}$ max	< 280	mΩ
Q_g typ	22	nC
I_{Dmax} @ 25 °C	19.0	A

Applications

- POWER FACTOR CORRECTION
- SERVER POWER SUPPLIES
- TELECOM POWER SUPPLIES
- INVERTER WELDERS
- MOTOR CONTROL

Contents

Contents.....	2
1. Maximum Ratings	3
2. Thermal Characteristics	4
3. Electrical Characteristics	5
4. Package Outlines.....	7
5. Revision History	9
6. Resources.....	9
7. Patents, Copyrights and Trademarks.....	9
8. Legal Disclaimer	9

1. Maximum Ratings

Table 2 Maximum Ratings

 @ $T_j = 25^\circ\text{C}$, unless otherwise specified

Parameter	Symbol	Values			Unit	Condition
		Min	Typ	Max		
Continuous drain current	I_D			7.3	A	$T_c = 100^\circ\text{C}$
				11.6	A	$T_c = 25^\circ\text{C}$
Pulsed drain current	$I_{D, \text{pulse}}$			46	A	$T_c = 25^\circ\text{C}$
Avalanche energy, single pulse	E_{AS}			260	mJ	$I_D = 5.1\text{A}; V_{DD} = 50\text{V}, V_{GS} = 10\text{V}, L=10\text{mH}, R_G=25\text{ Ohms}$
Avalanche energy, repetitive	E_{AR}			0.39	mJ	$I_D = 2.0; V_{DD} = 50\text{V}$
Avalanche current, single pulse	I_{AS}			1.8	A	
MOSFET dv/dt ruggedness	dv/dt			50	V/ns	$V_{DS} = 0 \dots 480\text{V}$
Gate source voltage (static)	V_{GS}	-30		30	V	Static
Gate source voltage (dynamic)	V_{GS}	-30		30	V	AC ($F > 1\text{Hz}$)
Power dissipation	P_{tot}			91	W	TO-220, TO-263, $T_c = 25^\circ\text{C}$
Storage temperature	T_{stg}	-55		150	$^\circ\text{C}$	
Operating junction temperature	T_j	-55		150	$^\circ\text{C}$	
Mounting torque				60	N-cm	M3 and M3.5 screws
Continuous diode forward current	I_{SD}			11.6	A	$T_c = 25^\circ\text{C}$
Diode pulse current	$I_{S, \text{pulse}}$			46	A	$T_c = 25^\circ\text{C}$
Reverse diode dv/dt	dv/dt			15	V/ns	$V_{DS}=0 \dots 480\text{V}, I_{SD} \leq I_S, T_j = 25^\circ\text{C}$
Maximum diode commutation speed	di/dt			300	A/ μs	$V_{DS}=0 \dots 480\text{V}, I_{SD} \leq I_S, T_j = 25^\circ\text{C}$

2. Thermal Characteristics

Table 3 Thermal Characteristics

Symbol	Parameter	Values				Unit
		TO-220	TO-220FP	TO-263	TO-247	
R_{th-jc}	Thermal resistance, junction-case	1.48	5.9	1.48	TBD	°C/W
R_{th-jA}	Thermal resistance, junction-ambient	65	65	65	TBD	°C/W
T_s	Soldering temperature, wave soldering only allowed at leads	260	260	260	TBD	°C

3. Electrical Characteristics

@ T_j = 25°C, unless otherwise specified

Table 4 Static Characteristics

Parameter	Symbol	Values			Unit	Condition
		Min	Typ	Max		
Drain-source breakdown voltage	V _{(BR)DSS}	650			V	I _D = 1mA, V _{GS} = 0V
Gate threshold voltage	V _{GS(TH)}	2.3	3	3.7	V	V _{DS} = V _{GS} , I _D = 72uA
Zero gate voltage drain current	I _{DSS}			1	μA	V _{DS} = 650V, T _C = 25°C, V _{GS} = 0V
				50		V _{DS} = 650V, T _C = 125°C, V _{GS} = 0V
Gate-source leakage current	I _{GSS}			100	nA	V _{GS} = ±30V, V _{DS} = 0V
Drain-source on-state resistance	R _{DS(on)}		0.26	0.28	Ω	V _{GS} = 10V, I _D = 5.8 A, T _J = 25°C
			0.63		Ω	V _{GS} = 10V, I _D = 5.8 A, T _J = 150°C
Gate resistance	R _G		1		Ω	

Table 5 Dynamic Characteristics

Parameter	Symbol	Values			Unit	Condition
		Min	Typ	Max		
Input capacitance	C _{iss}		940		pF	V _{DS} = 100V, f = 1MHz, V _{GS} = 0V
Output capacitance	C _{oss}		39.7		pF	
Reverse transfer capacitance	C _{rss}		7.6		pF	
Turn-on delay time	t _{d(on)}		5		ns	V _{DD} = 400V, I _D = 4.5A R _G = 3.4Ω, V _{GS} = 13V
Rise time	t _r		5		ns	
Turn-off delay time	t _{d(off)}		48		ns	
Fall time	t _f		27		ns	

Table 6 Gate Charge Characteristics

Parameter	Symbol	Values			Unit	Condition
		Min	Typ	Max		
Gate to source charge	Q _{gs}		4.4		nC	V _{DD} = 480V, I _D = 5.8A, V _{GS} = 0 to 10V
Gate to drain charge	Q _{gd}		8.4		nC	
Gate charge total	Q _g		22.2		nC	
Gate plateau voltage	V _{plateau}		5		V	

Table 7 Reverse Diode Characteristics

Parameter	Symbol	Values			Unit	Condition
		Min	Typ	Max		
Diode source-drain current	I_{SD}			11.6	A	
Diode forward voltage	V_{fd}		0.95	1.5	V	$I_{SD} = 11.6A, V_{GS} = 0V,$ $T_J = 25^{\circ}C$
Reverse recovery time	t_{rr}		219		ns	$I_F = 11.6A,$ $L = 5mH$ $di/dt = 100A/\mu S$ $V_{DD} = 60V, T_J = 25^{\circ}C$
Reverse recovery charge	Q_{rr}		2.0		μC	
Peak reverse recovery current	I_{rrm}		16.9		A	

4. Package Outlines

4a) TO-220

D3 Semiconductor TO-220-3L

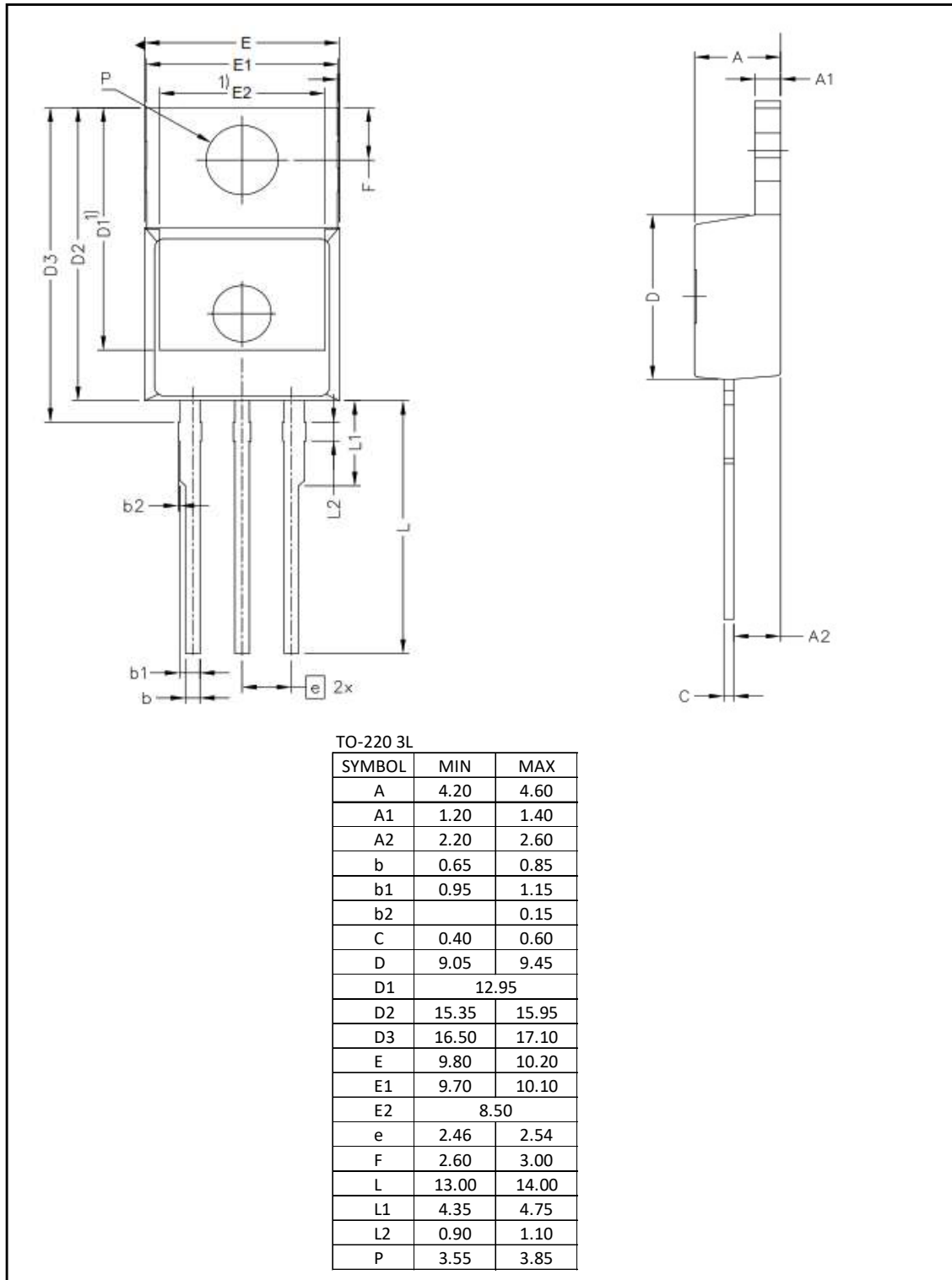

4b) TO-263

D3 Semiconductor TO-263 (D2PAK)

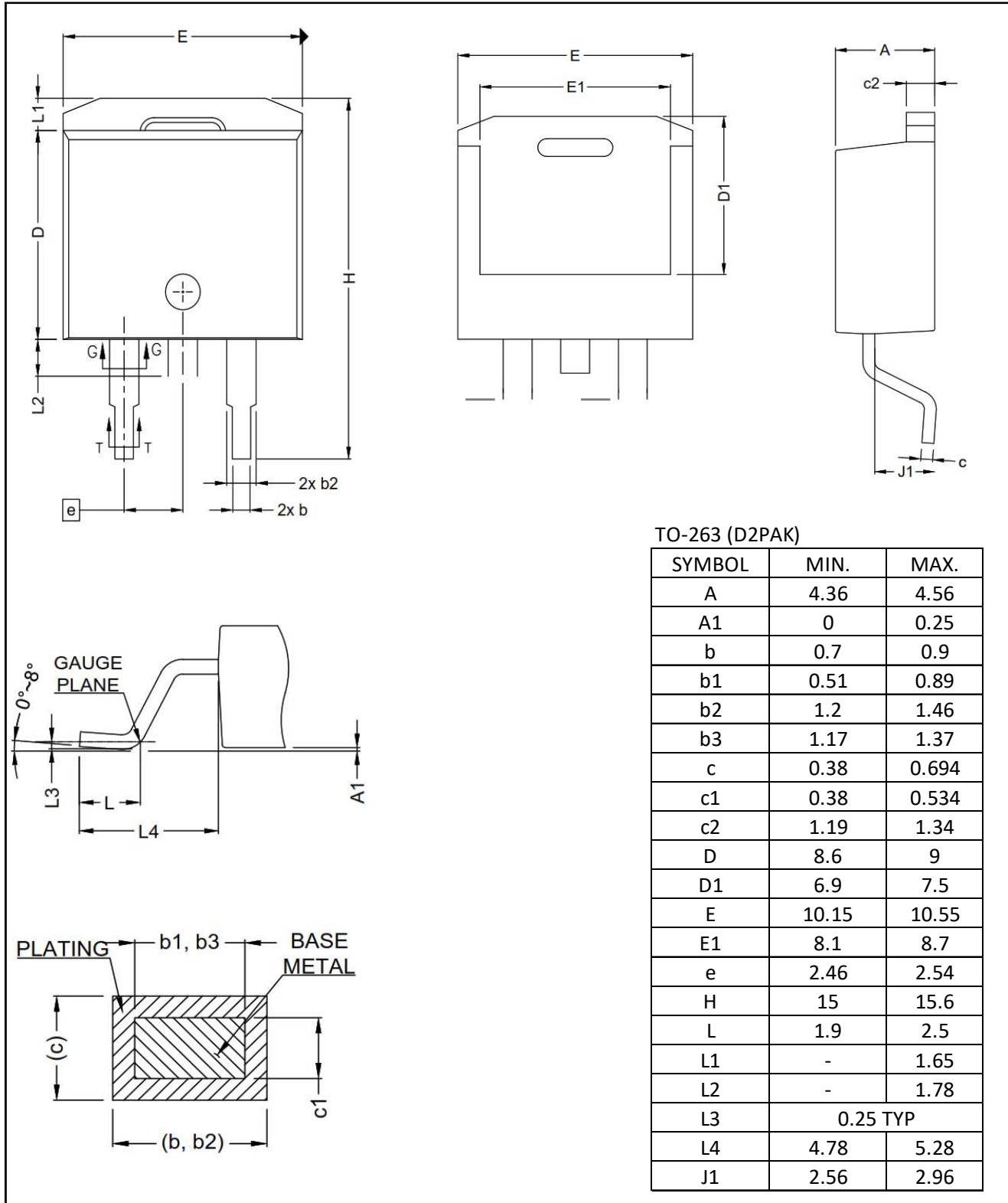

5. Revision History

Revision	Release Date	Comments
1.0	1-November-2016	Preliminary Datasheet Release
1.1	1-July-2017	Updated data tables and package information

6. Resources

www.d3semi.com

7. Patents, Copyrights and Trademarks

U.S. and Foreign Patents Pending.

The following are trademarks and service marks owned by D3 Semiconductor:

D3 Semiconductor[®], “Flying D” [®], +FET[™], Defining Precision Power[™].

All trademarks are property of their respective owners. © D3 Semiconductor 2016. All rights reserved

8. Legal Disclaimer

The information in this document is provided solely regarding D3 Semiconductor (“D3”) products. The information is not a guarantee of performance or characteristics. D3 Semiconductor reserves the right to modify, change, amend, improve or make corrections to this document, and its products, at any time and its sole discretion without prior written consent or notice. No license to any intellectual property rights is granted or implied under this document. D3 Semiconductor disclaims warranties and liabilities of any kind including non-infringement of intellectual property rights of any third party. D3 Semiconductor products may be used in applications such as automotive, military, aerospace, medical or other applications where failure or malfunction may result in personal injury, death or severe property or environmental damage only with express written approval from D3 Semiconductor. Sale of D3 Semiconductor products are subject to D3 Semiconductor’s standard terms and conditions. Products not purchased through D3 Semiconductor’s authorized distributors, agents or sales representatives are void of warranty.

Компания «Океан Электроники» предлагает заключение долгосрочных отношений при поставках импортных электронных компонентов на взаимовыгодных условиях!

Наши преимущества:

- Поставка оригинальных импортных электронных компонентов напрямую с производств Америки, Европы и Азии, а так же с крупнейших складов мира;
- Широкая линейка поставок активных и пассивных импортных электронных компонентов (более 30 млн. наименований);
- Поставка сложных, дефицитных, либо снятых с производства позиций;
- Оперативные сроки поставки под заказ (от 5 рабочих дней);
- Экспресс доставка в любую точку России;
- Помощь Конструкторского Отдела и консультации квалифицированных инженеров;
- Техническая поддержка проекта, помощь в подборе аналогов, поставка прототипов;
- Поставка электронных компонентов под контролем ВП;
- Система менеджмента качества сертифицирована по Международному стандарту ISO 9001;
- При необходимости вся продукция военного и аэрокосмического назначения проходит испытания и сертификацию в лаборатории (по согласованию с заказчиком);
- Поставка специализированных компонентов военного и аэрокосмического уровня качества (Xilinx, Altera, Analog Devices, Intersil, Interpoint, Microsemi, Actel, Aeroflex, Peregrine, VPT, Syfer, Eurofarad, Texas Instruments, MS Kennedy, Miteq, Cobham, E2V, MA-COM, Hittite, Mini-Circuits, General Dynamics и др.);

Компания «Океан Электроники» является официальным дистрибьютором и эксклюзивным представителем в России одного из крупнейших производителей разъемов военного и аэрокосмического назначения «JONHON», а так же официальным дистрибьютором и эксклюзивным представителем в России производителя высокотехнологичных и надежных решений для передачи СВЧ сигналов «FORSTAR».



JONHON

«JONHON» (основан в 1970 г.)

Разъемы специального, военного и аэрокосмического назначения:

(Применяются в военной, авиационной, аэрокосмической, морской, железнодорожной, горно- и нефтедобывающей отраслях промышленности)

«FORSTAR» (основан в 1998 г.)

ВЧ соединители, коаксиальные кабели, кабельные сборки и микроволновые компоненты:

(Применяются в телекоммуникациях гражданского и специального назначения, в средствах связи, РЛС, а так же военной, авиационной и аэрокосмической отраслях промышленности).



Телефон: 8 (812) 309-75-97 (многоканальный)

Факс: 8 (812) 320-03-32

Электронная почта: ocean@oceanchips.ru

Web: <http://oceanchips.ru/>

Адрес: 198099, г. Санкт-Петербург, ул. Калинина, д. 2, корп. 4, лит. А