

IB IL RS UNI(-2MBD)-PAC

**Inline communication terminal
for serial data transmission**

Data sheet
8235_en_01

© PHOENIX CONTACT 2012-03-14

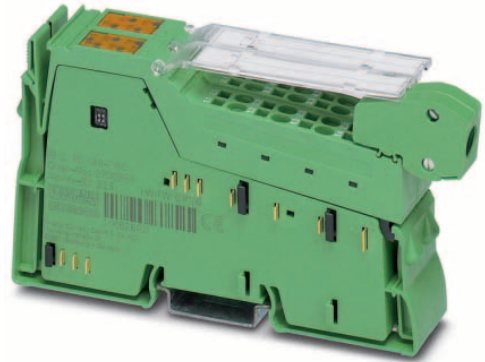

1 Description

The terminal is designed for use within an Inline station.
It is used to operate standard I/O devices with serial inter-
faces on a bus system.

Features

- A serial input and output channel in RS-232, RS-422 and RS-485 format
- Various protocols supported
- Transmission speed can be set up to 250000 baud
- Number of data bits, stop bits and parity can be set
- Parameterization via process data or PCP
- Process data width can be set via DIP switches: 7, 15 or 31 words
- Diagnostic and status indicators



This data sheet is only valid in association with the IL SYS INST UM E user manual.



Make sure you always use the latest documentation.
It can be downloaded from the product at www.phoenixcontact.net/catalog.

2	Table of contents	
1	Description	1
2	Table of contents	2
3	Ordering data	3
4	Technical data	3
5	Internal circuit diagram	5
6	Terminal point assignment.....	6
7	Local status and diagnostic indicators	7
8	Serial interfaces	8
9	Connection examples	9
10	Data storage and transmission	11
11	Programming data/configuration data.....	12
12	Process data.....	13
13	Process data word 0	14
14	Commands	16
15	PCP communication	21

3 Ordering data

Description	Type	Order No.	Pcs. / Pkt.
Inline communication terminal, for serial data transmission, complete with accessories (plug connector and labeling field), 1 serial input and output channel in RS-485/422 or RS-232 design	IB IL RS UNI-PAC	2700893	1
Inline communication terminal, for serial data transmission, complete with accessories (plug connector and labeling field), 1 serial input and output channel in RS-485/422 or RS-232 design, transmission speed 2 Mbaud	IB IL RS UNI-2MBD-PAC	2701025	1
Accessories	Type	Order No.	Pcs. / Pkt.
Connector set (Plug/Adapter)	IB IL AO/CNT-PLSET	2732664	1
Inline shield connector (Plug/Adapter)	IB IL SCN-6 SHIELD	2726353	5
Labeling field, width: 12.2 mm (Marking)	IB IL FIELD 2	2727501	10
Insert strip, Sheet, white, Unlabeled, Can be labeled with: Office-Drucksysteme, Plotter: Laser printer, Mounting type: Insert, Lettering field: 62 x 10 mm (Marking)	ESL 62X10	0809492	1
Documentation	Type	Order No.	Pcs. / Pkt.
User manual, English, Automation terminals of the Inline product range	IL SYS INST UM E	-	-
Data sheet, English, INTERBUS addressing	DB GB IBS SYS ADDRESS	-	-

4 Technical data

Dimensions (nominal sizes in mm)

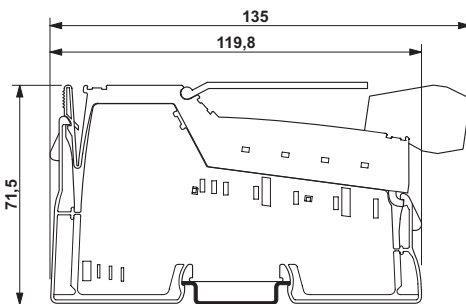

Width	24.4 mm
Height	136.8 mm
Depth	71.5 mm

General data

Color	green
Weight	135 g
Mounting type	DIN rail
Ambient temperature (operation)	-25 °C ... 55 °C
Ambient temperature (storage/transport)	-25 °C ... 85 °C
Permissible humidity (operation)	10 % ... 95 % (DIN EN 61131-2)
Permissible humidity (storage/transport)	10 % ... 95 % (DIN EN 61131-2)

General data

Air pressure (operation)	70 kPa ... 106 kPa (up to 3000 m above sea level)
Air pressure (storage/transport)	70 kPa ... 106 kPa (up to 3000 m above sea level)
Degree of protection	IP20
Protection class	III, IEC 61140, EN 61140, VDE 0140-1

Connection data

Name	Inline connectors
Connection method	Spring-cage connection
Conductor cross section solid / stranded	0.08 mm ² ... 1.5 mm ²
Conductor cross section [AWG]	28 ... 16

Interface Inline local bus

Connection method	Inline data jumper
-------------------	--------------------

Interface RS-232, RS-485, RS-422

Connection method	Spring-cage connection
Transmission physics	Copper

Transmission speed Inline local bus

IB IL RS UNI-PAC	500 kBit/s
IB IL RS UNI-2MBD-PAC	2 MBit/s

Power consumption

Main circuit supply U_M	24 V DC
I/O voltage range	19.2 V DC ... 30 V DC (including all tolerances, including ripple)
Current consumption from U_M	Typ. 15 mA
Current consumption from U_M	max. 25 mA
Communications power U_L	7.5 V (via voltage jumper)
Current consumption from U_L	Typ. 78 mA
Current consumption from U_L	max. 90 mA
Power loss	max. 1.2 W (Within the permissible operating temperature)



This terminal takes no current from the U_{ANA} und U_S potential jumpers.

Electrical isolation/isolation of the voltage areas

Serial interface/7.5 V supply (bus logic)	500 V AC , 50 Hz , 1 min
Serial interface/24 V supply U_M	500 V AC , 50 Hz , 1 min
Serial interface/functional earth ground	500 V AC , 50 Hz , 1 min
7.5 V supply (bus logics) / functional earth ground	500 V AC , 50 Hz , 1 min
24 V supply (U_M)/functional earth ground	500 V AC , 50 Hz , 1 min



Electrical isolation of the logic level from the serial interface is ensured by the DC/DC converter.
The serial interface control and data lines galvanically have the same potential. FE is a separate potential area.

Error messages to the higher level control or computer system

None

Approvals

For the latest approvals, please visit www.phoenixcontact.net/catalog.

5 Internal circuit diagram

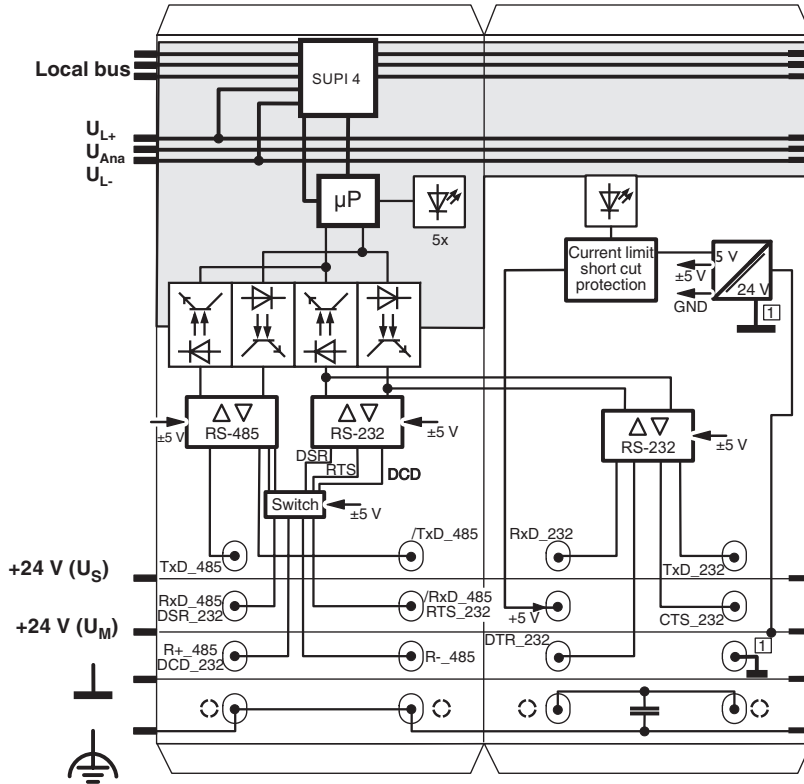













Figure 1 Internal wiring of the terminal points

Key:

	Protocol chip		Electrically isolated area
	Microprocessor		Capacitor
	RS-485/422/232 interface		Ground, electrically isolated from ground of the communications power U _L
	Diagnostic and status indicators		Explanation for other used symbols has been provided in the IL SYS INST UM E user manual.
	Optocoupler		
	DC/DC converter with electrical isolation		

6 Terminal point assignment

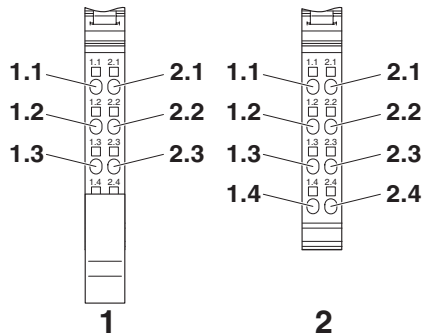

Figure 2 Terminal point assignment

6.1 RS-485/422 communication

Terminal point	Signal	Description	
Connector 1			
1.1	TxD+	Transmit data	positive
2.1	TxD-	Transmit data	negative
1.2	RxD+	Receive data	positive
2.2	RxD-	Receive data	negative
1.3	R+	Termination resistor	Positive pole
2.3	R-	Termination resistor	Negative pole
1.4 / 2.4	Shield	Shield connection, same potential as FE	
Connector 2			
The terminal points of this connector are not used.			

6.2 RS-232 communication

Terminal point	Signal		Description
Connector 1			
1.1 / 2.1	-		Not used
1.2	DSR	Data set ready	Connected device ready to operate; handshake signal; input
2.2	RTS	Request to send	Request to send; handshake signal; output
1.3	DCD	Data carrier detect	Connected device ready to operate; handshake signal; input
2.3	-		Not used
1.4 / 2.4	-		Not used
Connector 2			
1.1	RxD		Serial data input
2.1	TxD		Serial data output
1.2	+5 V DC		Control output; internally wired to +5 V
2.2	CTS	Clear to send	Permission to send; connected device ready to receive; handshake signal; input
1.3	DTR	Data terminal ready	Startup request to the connected device; handshake signal; output
2.3	GND		Ground for the serial interface
1.4 / 2.4	Shield		Shield connection, capacitive to FE



Ensure that on connector 2, terminal point 1.2 (+5 V DC) is exclusively used to provide the 5 V signal for the CTS input (terminal point 2.2), in the event of communication without a handshake. In this case, insert a jumper between the terminal points.

7 Local status and diagnostic indicators

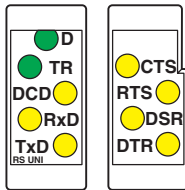

Figure 3 Local status and diagnostic indicators

Designation	Color	Meaning
D	green	Diagnostics (bus and logic voltage)
TR	Green	PCP communication
DCD	Yellow	Data carrier detect
RxD	Yellow	Terminal receives data from the connected device
TxD	Yellow	Terminal transmits data to the connected device
CTS	Yellow	Clear to send
RTS	Yellow	Request to send
DSR	Yellow	Data set ready
DTR	Yellow	Data terminal ready



For detailed information on diagnostics, please refer to the IL SYS INST UM E user manual.

Function identification

Orange

2 Mbps: White stripe in the vicinity of the D LED

8 Serial interfaces

8.1 RS-232

The RS-232 interface on the terminal represents some form of DTE (data termination equipment).

This means that connector 2 terminal point 2.1 (TxD) is always used to transmit and connector 2 terminal point 1.1 (RxD) is always used to receive.

According to the standard, some form of DCE (data communication equipment) should be connected to the RS-232 interface as a peer. DTE can also be connected.

Measuring the voltage between the connection points for the TxD and GND signals in idle state will determine whether the device to be connected to the RS-232 interface is a form of DTE or DCE. If the voltage measures approximately -5 V, the device is a form of DTE. If the voltage is approximately 0 V, the device is a form of DCE.

Example: When using a 25-pos. standard connector the voltage between pin 2 (TxD) and pin 7 (GND) must be measured.

RS-232 module handshake signals

Any device with a RS-232 interface can be connected to the RS-232 interface on the terminal. Both the terminal and the device connected to the RS-232 interface can act as a transmitter and a receiver for data exchange. As errors can occur during data exchange if both devices transmit or receive simultaneously, the handshake is used as a procedure for the mutual signaling of clear to receive and clear to transmit.

The terminal supports the RTS, CTS, CTR, DSR and DCD handshake signals. Each uses one wire of the connecting cable.

The connecting signals are described from the point of view of the terminal, i.e., from the point of view of the DTE.

8.2 RS-485

In RS-485 operating mode, an RS-485 network with several devices can be created.

Use a twisted-pair, shared and shielded data line to connect the devices. Fit this data line with termination resistors at the two most remote points of the RS-485 network. Use the termination resistor integrated in the device when connecting the Inline terminal.

This operating mode supports half-duplex transmission. Make sure that only one device is transmitting data at a time.

To ensure a defined idle cable state, the terminal contains data line polarization.

8.3 RS-422

In RS-422 operating mode, a point-to-point connection can be established.

Use a twisted-pair, shared and shielded data line to connect the devices. Fit this data line with termination resistors at every device. Use the termination resistor integrated in the device when connecting the Inline terminal.

This operating mode supports full duplex transmission.

9 Connection examples

Operating mode	Special feature	Shield connection	Notes	Required connectors
RS-485	Inline terminal as network end point	Directly	Termination resistor required	Supplied connectors (connector set)
RS-485	Inline terminal as network end point	With a capacitor	Termination resistor required	Supplied connectors (connector set)
RS-485	Terminal in the network center	With a capacitor/directly	-	2 shield connectors
RS-422	Shield connected using a capacitor	With a capacitor	Termination resistor required	Supplied connectors (connector set)



The connector set consists of a shield connector and a standard connector. It is supplied as standard.

9.1 RS-485: Terminal as the network end point



Connect the shield directly to FE.

Please observe the following when wiring:

- Always connect the shield between two devices on one side using a capacitor and on the other side directly to FE.
- Fit a termination resistor to the RS-485 network beginning and end.
- For an RS-422 point-to-point connection, the receive signals on every device must be fitted with termination resistors.

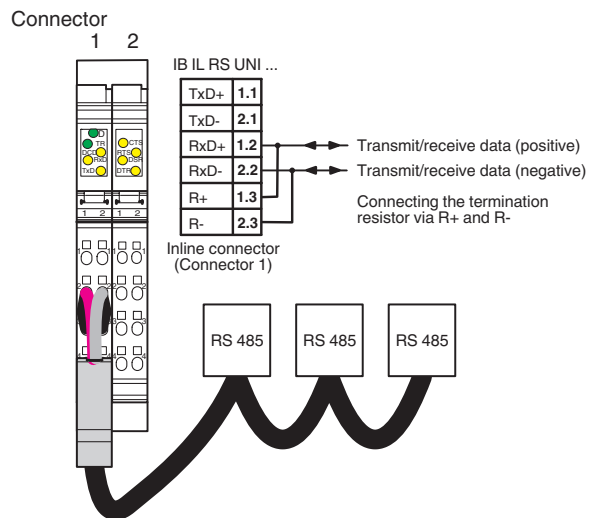

Figure 4 RS-485 interface wiring: Terminal as end point of a network, shield or data cable directly connected to FE

9.2 RS-485: Terminal as the network end point



Connect the shield to FE using a capacitor.

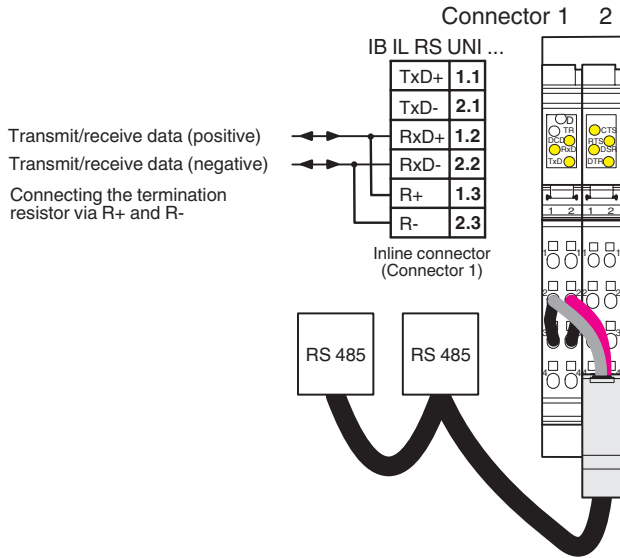

Figure 5 RS-485 interface wiring: Terminal as end point of a network, shield or data cable connected capacitively to FE

9.3 RS-485: Terminal in the network center

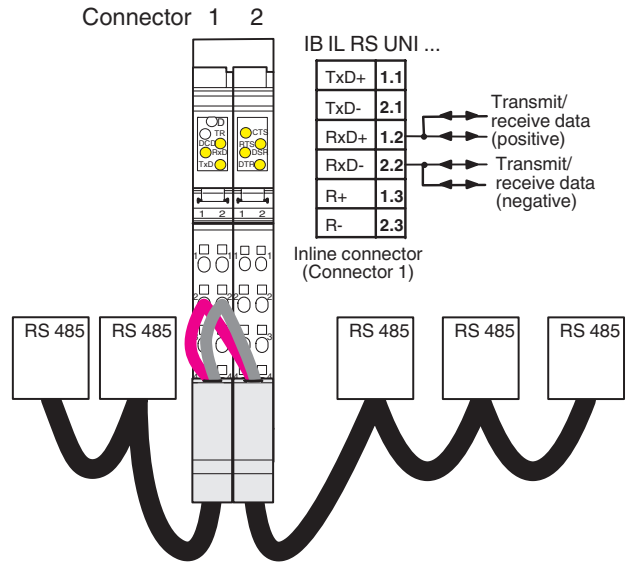

Figure 6 RS-485 interface wiring: Terminal in the center of a network, data line shield connected directly capacitively to FE

9.4 RS-422: Shield connected to the terminal using a capacitor

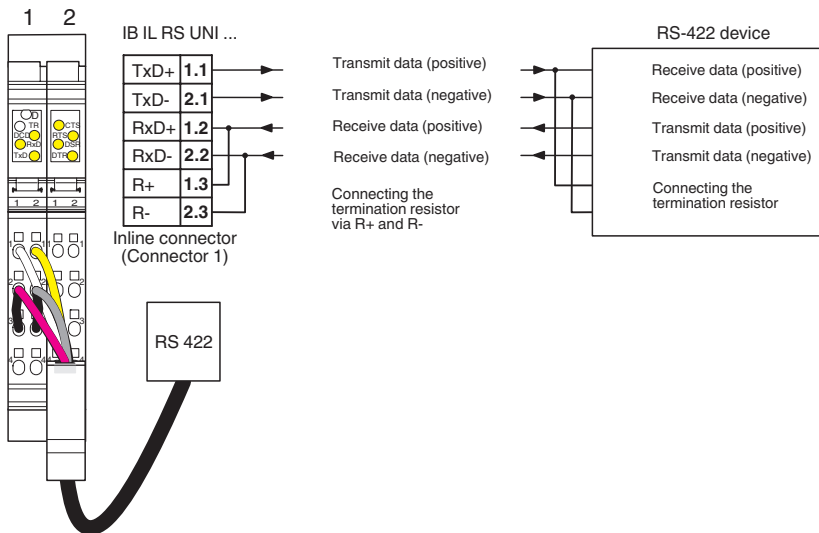

Figure 7 RS-422 interface wiring: Data line shield connected capacitively to FE

9.5 RS-232: With 4-wire handshake

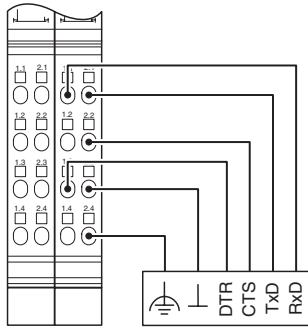

Figure 8 RS-232 interface wiring: data cable shield connected capacitively to FE

9.6 RS-232: Without handshake

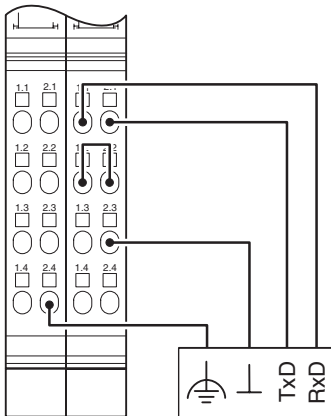

Figure 9 RS-232 interface wiring: data cable shield connected directly to FE

For wiring without handshake, insert a bridge between terminal points 1.2 (+5 V) and 2.2 (CTS).

10 Data storage and transmission

The terminal stores the received serial data in an intermediate buffer until it is requested from the serial interface by the bus controller board or the device. Serial data traffic can be managed using various protocols. The protocol used depends on the type of protocol supported by the peer.

10.1 Supported protocols

Protocol	Receive memory	Transmit memory	Special features when receiving
Transparent	4096 bytes	1023 bytes	
End-to-end	3 buffers with 330 bytes each	1023 bytes (including end characters)	Two end characters are filtered out
XON/XOFF	4096 bytes	1023 bytes	Software handshake

10.2 Transparent protocol

If the transparent protocol is used, serial data is transmitted in the same format it is received from the serial interface or from the bus side.

The transmit FIFO (First-In-First-Out memory) can store 1023 bytes (1 kbyte) and the receive FIFO can store 4096 bytes (4 kbytes). If the terminal receives another character after the 4095th character, the error pattern is stored in the receive FIFO. All other subsequent characters are ignored.

This protocol supports a CTS hardware handshake.

If the available space in the receive memory is less than 15 bytes, DTR is set to logic 0. As soon as more memory space becomes available again, DTR is set to logic 1.

10.3 End-to-end protocol

The serial data is conditioned for the end-to-end protocol.

If serial data is sent from the bus side, two additional characters, the first and second delimiters, are attached for transmission to the serial interface.

A block of serial data sent from the serial interface is only valid if the terminal has received the first and second delimiters. Only then the data can be read via the bus side. The delimiters are filtered out.

Unlike in the transparent protocol, the receive memory is not organized as a FIFO but as a buffer. There are 3 buffers available, each with 330 bytes. If the buffer size of 330 bytes is exceeded without the two delimiters being detected, the previous characters will be ignored and the buffer will be written again.

The transmit FIFO can store 1023 bytes (1 kbyte). The delimiters are attached to, and stored with, the data to be sent.

10.4 XON/XOFF protocol

This protocol operates in the same way as the transparent protocol, but uses a software handshake.

Data transmission with this protocol is controlled by the XON and XOFF characters. XON is preset to 11_{hex} and XOFF to 13_{hex}.

If the terminal receives an XOFF, no more serial data will be sent until an XON is received.

The terminal itself will transmit an XOFF if the available space in the receive memory is less than 15 bytes. As soon as more memory space becomes available again, the terminal will transmit a single XON.

Transmission does not depend on the CTS input.

Transmission of serial data is not filtered. So any characters occurring with the code defined for XON and XOFF are transmitted and may trigger undesirable events at the receiver.

When serial data is received, the XON and XOFF characters are filtered and are not available as data. Any characters with the XON or XOFF code are lost. Ensure that characters with these codes do not appear in the data stream.

11 Programming data/configuration data

11.1 Local bus (INTERBUS)

ID code [hex]	DF	DF	DF
ID code (dec)	223	223	223
Length code [hex]	07	0F	1F
Process data channel	112 bits	240 bits	496 bits
Input address space	7 words	15 words	31 words
Output address space	7 words	15 words	31 words
Parameter channel (PCP)	1 word	1 word	1 word
Register length (bus)	8 words	16 words	32 words

11.2 Other bus systems or networks



For the programming data/configuration data of other bus systems, please refer to the corresponding electronic device data sheet (e.g., GSD, EDS).

12 Process data

The process image width of the terminal depends on the DIP switch positions and comprises 7, 15 or 31 data words in input and output direction respectively.

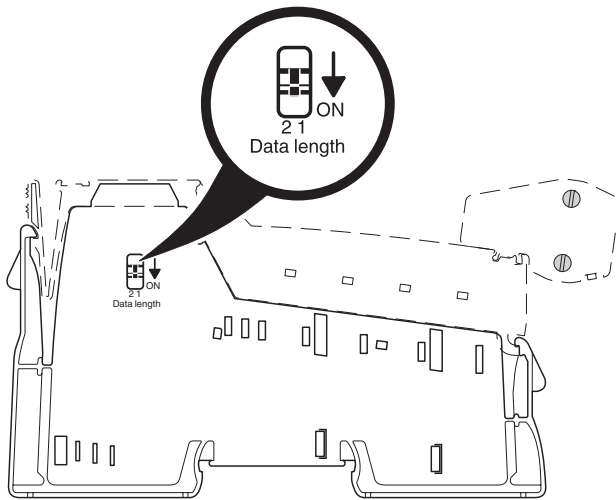

Switch 2	Switch 1	Data width	User data when transmitting and reading
OFF	OFF	7 words	11 bytes
OFF	ON	15 words	27 bytes
ON	OFF	31 words	59 bytes
ON	ON	Reserved	Reserved



For the assignment of the illustrated (byte.bit) view to your INTERBUS control or computer system, please refer to the DB GB IBS SYS ADDRESS data sheet.

Figure 10 DIP switches

Example for the assignment of seven words of process data

Word	0		1		2		3		4		5		6	
Byte in the Motorola format	0	1	2	3	4	5	6	7	8	9	10	11	12	13
Byte in the Intel format	1	0	3	2	5	4	7	6	9	8	11	10	13	12
OUT	K/P	S	L	D	D	D	D	D	D	D	D	D	D	D
IN	K/P	S	L	D	D	D	D	D	D	D	D	D	D	D

- K/P Command/parameter
- S Control bits (OUT) or status bits (IN)
- L Length: Number of characters to be written (OUT) or to be read (IN)
- D Data



The byte representation in the Motorola format, also called Big Endian (high order byte at starting address) corresponds to the INTERBUS standard representation. All byte representations in the data sheet have this format.

The byte representation in the Intel format is also called Little Endian (low order byte at starting address).

The command is used to determine the function. The actually transmitted data depends on the command.

13 Process data word 0

13.1 Control word

15	14	13	12	11	10	9	8	7	6	5	4	3	2	1	0
0		Command				OUT parameter			Control bits						

7	6	5	4	3	2	1	0
DTR	0	0	0	0	Reset transmit error	Reset receive error	0

DTR (if DTR control enabled)	
Code [bin]	Meaning
0	DTR = logic 0
1	DTR = logic 1



The DTR signal can only be controlled when DTR control is enabled via process data, that is when the DTR control bit has been enabled in the configuration (see "Write configuration" command).

Code [bin]	Meaning
Reset transmit error	
0	No action
1	Reset transmit error

Reset receive error	
Code [bin]	Meaning
0	No action
1	Reset receive error



The listed protocols do not support transmit and receive errors.

Commands

Code [bin]	Code [hex]	Command
000	0	Read number of characters received
001	1	Transmit characters
010	2	Store characters temporarily
011	3	OUT parameter = 0 _{hex} : Read characters
011	3	OUT parameter = C _{hex} : Read firmware version
011	3	OUT parameter = D _{hex} : Read configuration
011	3	OUT parameter = E _{hex} : Read counters
100	4	Write configuration
101	5	Toggling command 1: Transmit characters
110	6	Toggling command 2: Store characters temporarily
111	7	Toggling command 3: Read characters

Command toggling

Command toggling is used to execute a command on a terminal again. In this way, a second command code is available for the same function.

This applies for the following commands:

- Transmit characters
- Store characters temporarily
- Read characters
- Read counters

Here, bit 14 is used for toggling. If, for example, you wish to transmit character strings in sequence, use command code 001_{hex} for the first transmission and then use 101_{hex} and 001_{hex} alternately.

13.2 Status word

15	14	13	12	11	10	9	8	7	6	5	4	3	2	1	0
St	Command			IN parameter				Status bits							

St Error bit

Reasons for an error bit set:

- Invalid parameter for the specified command
- Failure of the I/O voltage

Status bits

7	6	5	4	3	2	1	0
DSR	Transmit buffer not empty	Transmit buffer full	Receive buffer full	DCD	Transmit error	Receive error	Receive buffer not empty

DSR	
Code [bin]	Meaning
0	DSR = logic 0
1	DSR = logic 1

Receive error	
Code [bin]	Meaning
0	No error
1	Receive error

Transmit buffer not empty	
Code [bin]	Meaning
0	Empty
1	Not empty

Code [bin]	Meaning
Receive buffer not empty	
0	Empty
1	Not empty

Transmit buffer full	
Code [bin]	Meaning
0	Not full
1	Full



The listed protocols do not support transmit and receive errors.

Receive buffer full	
Code [bin]	Meaning
0	Not full
1	Full

DCD	
Code [bin]	Meaning
0	DCD = logic 0
1	DCD = logic 1

Transmit error	
Code [bin]	Meaning
0	No error
1	Transmit error

14 Commands

14.1 "Read number of characters received" command

The command result is the number of characters that have been received but not yet read.

This command can be used to first reach a minimum number of characters before transmitting the "Read characters" command.

Process data assignment for the "Read number of characters received" command (process data width: 7 words)

Word	0		1		2		3		4		5		6	
Byte	0	1	2	3	4	5	6	7	8	9	10	11	12	13
OUT	00 _{hex}	xx	xx	xx	xx	xx	xx	xx	xx	xx	xx	xx	xx	xx
IN	00 _{hex}	Status bits	Read number of characters received		xx	xx	xx	xx	xx	xx	xx	xx	xx	xx

14.2 "Transmit characters" command

The transmit data located in the process data is stored in the transmit memory. From there the data is transmitted directly via the interface. Depending on the process data width a maximum of 11, 27 or 59 characters can be transmitted. Enter the

number of characters to be transmitted in the third byte. If there are characters in the intermediate buffer, these are transmitted first. After the command has been executed successfully, the intermediate buffer is cleared.

Process data assignment for the "Transmit characters" command with 11 characters (Z1 - Z11; process data width: 7 words)

Word	0		1		2		3		4		5		6	
Byte	0	1	2	3	4	5	6	7	8	9	10	11	12	13
OUT	10 _{hex}	xx	0B _{hex}	C1	C2	C3	C4	C5	C6	C7	C8	C9	C10	C11
IN	10 _{hex}	Status bits	xx	xx	xx	xx	xx	xx	xx	xx	xx	xx	xx	xx

Reasons for an error bit set:

- Byte 2 (number of characters to be transmitted) = 0 or > maximum user data length (11, 27 or 59 characters)
- "Neutral" interface type

14.3 "Store characters temporarily" command

The transmit data located in the process data is stored in an intermediate buffer, which can store up to 330 characters. No characters are transmitted. The "Transmit characters" command is used to transmit temporarily stored data. In this way, blocks of up to 330 characters can be transmitted. They are, for example, divided into 30 telegrams, each with 11 characters.

Reasons for an error bit set:

- Byte 2 (number of characters to be transmitted) = 0 or > maximum user data length (11, 27 or 59 characters)
- Not enough space in the intermediate buffer

14.4 "Read characters" command

Depending on the process data width set a maximum of 11, retains the number of valid characters available in the input 27 or 59 characters can be read. The third byte (byte 2) contains data.

Process data assignment for the "Read characters" command with eleven characters (C1 - C11)

Word	0		1		2		3		4		5		6	
Byte	0	1	2	3	4	5	6	7	8	9	10	11	12	13
OUT	30 _{hex}	xx	xx	xx	xx	xx	xx	xx	xx	xx	xx	xx	xx	xx
IN	30 _{hex}	Status bits	0B _{hex}	C1	C2	C3	C4	C5	C6	C7	C8	C9	C10	C11

Bit 7 in the third input byte (byte 2)

Byte 2, bit 7	Effect	Protocol
0	The characters read are the last ones in the block received.	E.g., end-to-end
1	There are still more characters to be read from the block received.	E.g., end-to-end

14.5 "Read counters" command

This command can be used to read several counters. The counters are used for interface diagnostics.

Process data assignment for the "Read counters" command

Word	0		1		2		3	
Byte	0	1	2	3	4	5	6	7
OUT	3E _{hex}	00 _{hex}	xx	xx	xx	xx	xx	xx
IN	3E _{hex}	Status bits	Number of valid characters received		Number of invalid characters received (parity, overrun or framing errors)		Number of characters transmitted	

14.6 "Write configuration" command

Output words 0 to 6

Process data assignment for the "Write configuration" command

Word	0		1		2		3		4		5		6	
Byte	0	1	2	3	4	5	6	7	8	9	10	11	12	13
OUT	40 _{hex}	xx	T/P	B/DB	1st del	2nd del	ErrP	Uni1	Uni2	Uni3	res.	res.	Tv	Tn
IN	40 _{hex}	Status bits	-	-	-	-	-	-	-	-	-	-	-	-

Element value range



The options in bold are default settings.

Byte 2 (T/P: interface type/protocol)

7	6	5	4	3	2	1	0
res.	DTR	Interface type	Protocol				

DTR: DTR control	
Code [bin]	Meaning
0	Automatic
1	Can be controlled via process data

Interface type	
Code [bin]	Meaning
00	RS-232
01	RS-485
10	RS-422
11	Neutral



Select an RS-xxx interface type. With the "neutral" default setting, no data is transmitted or received. When using the default setting, an error message is generated and the error bit is set.

Protocol	
Code [hex]	Meaning
0	Transparent
1	End-to-end
2	XON/XOFF
Other	Reserved

Byte 3 (D/DB: baud rate/data width)

Baud rate	
Code [hex]	Wert [baud]
0	110
1	300
2	600
3	1200
4	1800
5	2400
6	4800
7	9600
8	15625
9	19200
A	38400
B	57600
C	115200
D	230400
E	250000
F	Direct (Uni1 ... 3)



The specified baud rates of 110 baud to 250000 baud are adequate for most applications. However, you can freely choose the baud rate by direct programming. For this, use the 0F_{hex} baud rate code.



The specified combinations of data width, parity and stop bits are adequate for most applications. However, you can freely choose the combination by direct programming. For this, use the 0F_{hex} data width code.

Byte 4 and 5 (1st del, 2nd del: 1st and 2nd delimiters)

The 1st delimiter and 2nd delimiter contain the end characters for the end-to-end and dual buffer protocols.

When selecting the end-to-end protocol, the two delimiters can be adjusted.

Default settings:

Delimiter	Default value	ASCII character
1st del	0D _{hex}	CR = carriage return
2nd del	0A _{hex}	LF = line feed

Byte 6 (ErrP: error pattern)

The error pattern contains the character that is written to the FIFO if a character was received with errors (e.g., in the event of a parity error).

The error pattern is used for the following protocols:

- Transparent
- End-to-end
- XON/XOFF

Data width			
Code [hex]	Meaning		
	Data bits	Parity	Stop bits
-			
0	7	Even	1
1	7	Odd	1
2	8	Even	1
3	8	Odd	1
4	8	Without	1
5	7	Without	1
6	7	Even	2
7	7	Odd	2
8	8	Even	2
9	8	Odd	2
A	8	Without	2
B	7	Without	2
C	8	Constantly at 0	1
D	8	Constantly at 1	1
E	6	Without	1
F	Directly (Uni1)		

Error pattern	
Code [hex]	Meaning
24	\$
xx	Any character
00	If a character is received with an error, no error pattern is stored.
FF	The invalid character is stored instead of the error pattern.

Byte 7 ... 9 (Uni1 ... Uni3: universal byte 1 ... 3)

These bytes can be used as universal bytes for direct specification of the baud rate or the data width.

Byte 7								Byte 8			Byte 9		
7	6	5	4	3	2	1	0	7	...	0	7	...	0
Data width								Baud rate					

Direct specification of baud rate

If the provided baud rates do not correspond to the desired baud rate, the baud rate can be directly specified. For this, write the desired baud rate on the Uni1 to Uni3 fields in the form of a numeric value. Transfer is right-aligned. However, only the 2 lower bits of Uni1 are permitted.

The maximum value is 18 bits. The maximum value = 3FFFF_{hex} which corresponds to 262143 baud.

Direct specification of the data width

If the provided combinations of data width, parity and stop bits are inadequate, they can be directly specified. Use the Uni1 byte. Bit 1 and bit 0 are reserved.

7	6	5	4	3	2	1	0
Parity		Enable parity		Stop bits	Data bits		res. res.

Parity	
Code [bin]	Meaning
00	Odd
01	Even
10	Constantly at 1
11	Constantly at 0

Enable parity	
Code [bin]	Meaning
0	Disable
1	Enable

Stop bits	
Code [bin]	Meaning
0	1 stop bit
1	2 stop bits

Data bits	
Code [bin]	Meaning
00	5 bits
01	6 bits
10	7 bits
11	8 bits

Example for direct specification of the baud rate:

- Baud rate: 100000 baud
- 100000_{dec} = 01 86 A0_{hex}

Word	0		1		2		3		4		5		6	
Byte	1	1	2	3	4	5	6	7	8	9	10	11	12	13
OUT	40 _{hex}	xx _{hex}	T/P	B/DB	res.	res.	ErrP	Uni1	Uni2	Uni3	res.	res.	Tv	Tn
OUT	40 _{hex}	xx _{hex}	xx	Fx _{hex}	00	00	xx	01	86	A0	00	00	xx	xx

Byte 12 und 13 (Tv, Tn: lead time, lag time)

These two times are used for the RS-232 protocol

Tv	Lead time
Tn	Lag time

The times are specified with a resolution of 1 ms. This allows for waiting times of 1 ms ... 255 ms.

When transmitting data via RS-232 the RTS signal is set. If Tv does not equal 0, transmission only starts after this time has elapsed. After all the data is sent and Tn does not equal 0, the RTS signal is only set to LOW after this time has elapsed.

15 PCP communication**15.1 General information**

For information on PCP communication, please refer to the PCP user manuals (see Ordering data).

By default upon delivery, the terminal is configured according to the default settings (under configuration). The terminal can be configured using process data or PCP to suit your application.

In PCP mode, the terminal is configured with the "Config Table" object.



The programs IBS CMD (for standard controller boards) and PC WorX (for Controllers (ILC), Field Controllers (FC) and Remote Field Controllers (RFC)) are available for the configuration and parameterization of your INTERBUS system.

For additional information, please refer to the documentation of the software used.

15.2 Object dictionary for PCP communication

Index	Data type	A	L	Meaning	Object name	Rights
0080 _{hex}	Record	1	16	Terminal configuration	Config Table	rd/wr

A Number of elements rd Read access permitted
 L Length of an element in bytes wr Write access permitted

15.3 "Config Table" object

Configure the terminal using this object.

Access this object via subindex 0, i.e., read or write the entire project.

The first twelve bytes correspond to byte 2 through byte 13 of the "Write configuration" command. The other four bytes are reserved.

Byte	Meaning	Default value
0	Type, protocol	00 _{hex}
1	Baud rate, data width	72 _{hex}
2	1st delimiter	0D _{hex}
3	2nd delimiter	0A _{hex}
4	Error pattern	24 _{hex}
5 ... 7	Uni1 ... Uni3	00 00 00 _{hex}
8, 9	Reserved	00 00 _{hex}
10	Tv	00 _{hex}
11	Tn	00 _{hex}
12 ... 15	Reserved	00 00 00 00 _{hex}

If an invalid configuration is specified, a negative confirmation is generated with error message 08_{hex}, 00_{hex} or xx30_{hex}. The low byte of the Additional_Error_Code is 30_{hex} (value is out of range), the high byte contains the number of the affected byte.

Компания «Океан Электроники» предлагает заключение долгосрочных отношений при поставках импортных электронных компонентов на взаимовыгодных условиях!

Наши преимущества:

- Поставка оригинальных импортных электронных компонентов напрямую с производств Америки, Европы и Азии, а так же с крупнейших складов мира;
- Широкая линейка поставок активных и пассивных импортных электронных компонентов (более 30 млн. наименований);
- Поставка сложных, дефицитных, либо снятых с производства позиций;
- Оперативные сроки поставки под заказ (от 5 рабочих дней);
- Экспресс доставка в любую точку России;
- Помощь Конструкторского Отдела и консультации квалифицированных инженеров;
- Техническая поддержка проекта, помощь в подборе аналогов, поставка прототипов;
- Поставка электронных компонентов под контролем ВП;
- Система менеджмента качества сертифицирована по Международному стандарту ISO 9001;
- При необходимости вся продукция военного и аэрокосмического назначения проходит испытания и сертификацию в лаборатории (по согласованию с заказчиком);
- Поставка специализированных компонентов военного и аэрокосмического уровня качества (Xilinx, Altera, Analog Devices, Intersil, Interpoint, Microsemi, Actel, Aeroflex, Peregrine, VPT, Syfer, Eurofarad, Texas Instruments, MS Kennedy, Miteq, Cobham, E2V, MA-COM, Hittite, Mini-Circuits, General Dynamics и др.);

Компания «Океан Электроники» является официальным дистрибьютором и эксклюзивным представителем в России одного из крупнейших производителей разъемов военного и аэрокосмического назначения «JONHON», а так же официальным дистрибьютором и эксклюзивным представителем в России производителя высокотехнологичных и надежных решений для передачи СВЧ сигналов «FORSTAR».



JONHON

«JONHON» (основан в 1970 г.)

Разъемы специального, военного и аэрокосмического назначения:

(Применяются в военной, авиационной, аэрокосмической, морской, железнодорожной, горно- и нефтедобывающей отраслях промышленности)

«FORSTAR» (основан в 1998 г.)

ВЧ соединители, коаксиальные кабели, кабельные сборки и микроволновые компоненты:

(Применяются в телекоммуникациях гражданского и специального назначения, в средствах связи, РЛС, а так же военной, авиационной и аэрокосмической отраслях промышленности).



Телефон: 8 (812) 309-75-97 (многоканальный)

Факс: 8 (812) 320-03-32

Электронная почта: ocean@oceanchips.ru

Web: <http://oceanchips.ru/>

Адрес: 198099, г. Санкт-Петербург, ул. Калинина, д. 2, корп. 4, лит. А