

IS31LT3380

40V/1.2A LED DRIVER WITH SWITCH DIMMING

OCTOBER 2011

GENERAL DESCRIPTION

The IS31LT3380 is a continuous mode inductive step-down converter, designed for driving a single LED or multiple series connected LEDs efficiently from a voltage source higher than the LED voltage. The chip operates from an input voltage between 8.5V and 40V and provides an output current up to 1.2A.

The IS31LT3380 includes a high-side output current sensing circuit, which uses an external resistor to set the nominal average output current. The IS31LT3380 includes an integrated output switch which has a very low conducting impedance to ensure high system efficiency. The IS31LT3380 has switch dimming function. The chip detects external switch action to adjust output current, allowing for dimming functionality to be achieved without changing the original lighting system circuitry.

The switch dimming is implemented in either two-level mode or three-level mode. The output current of every level and the total number of levels are customer selected by setting the corresponding input conditions of DIM1 and DIM2 pin.

The output current is set at the initial value the first time that power is supplied to the chip. After the initial power up sequence, the chip adjusts the output current according to the external switch action. After the lowest current level, the current cycles back to the initial value if more switch action is detected. If the power is switched off for longer than 2 seconds, the device will return to its initial state, and the output current will be set to the initial value at the next time that power is applied.

FEATURES

- Multi-modes switch dimming
- Up to 1.2A output current
- High efficiency (up to 98%)
- Wide input voltage range: 8.5V to 40V
- Internal 40V power switch
- Simple low parts count
- Typical 5% output current accuracy
- Up to 1MHz switching frequency
- Inherent LED open-circuit/short-circuit protection
- Thermal shutdown protection circuitry
- SOP8 package

APPLICATIONS

- MR16, MR11 LED spotlight
- LED street lighting
- PAR LED bulb
- Other LED lighting

Copyright © 2011 Integrated Silicon Solution, Inc. All rights reserved. ISSI reserves the right to make changes to this specification and its products at any time without notice. ISSI assumes no liability arising out of the application or use of any information, products or services described herein. Customers are advised to obtain the latest version of this device specification before relying on any published information and before placing orders for products. Integrated Silicon Solution, Inc. does not recommend the use of any of its products in life support applications where the failure or malfunction of the product can reasonably be expected to cause failure of the life support system or to significantly affect its safety or effectiveness. Products are not authorized for use in such applications unless Integrated Silicon Solution, Inc. receives written assurance to its satisfaction, that:

- a.) the risk of injury or damage has been minimized;
- b.) the user assume all such risks; and
- c.) potential liability of Integrated Silicon Solution, Inc is adequately protected under the circumstances

IS31LT3380

APPLICATION CIRCUIT

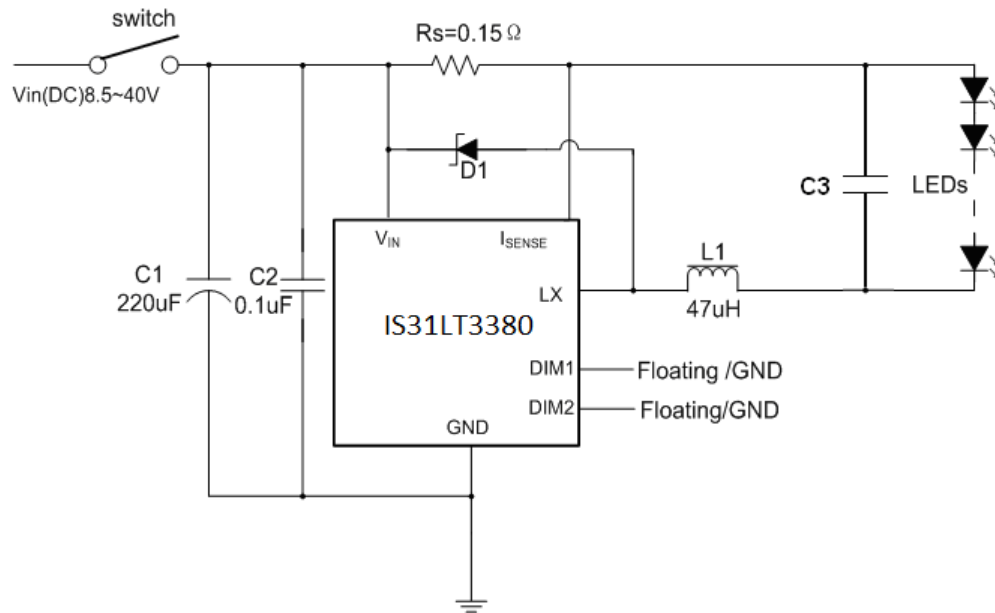

Figure 1-A

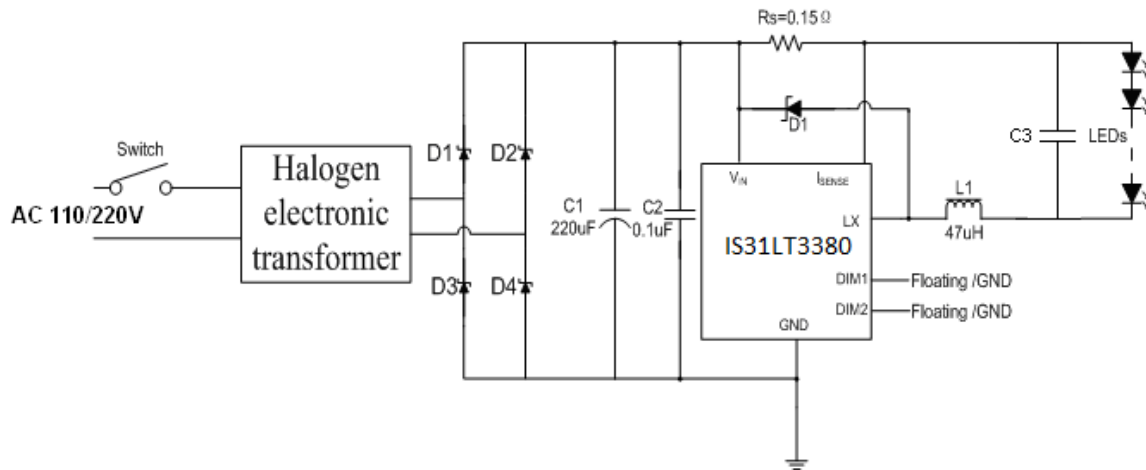
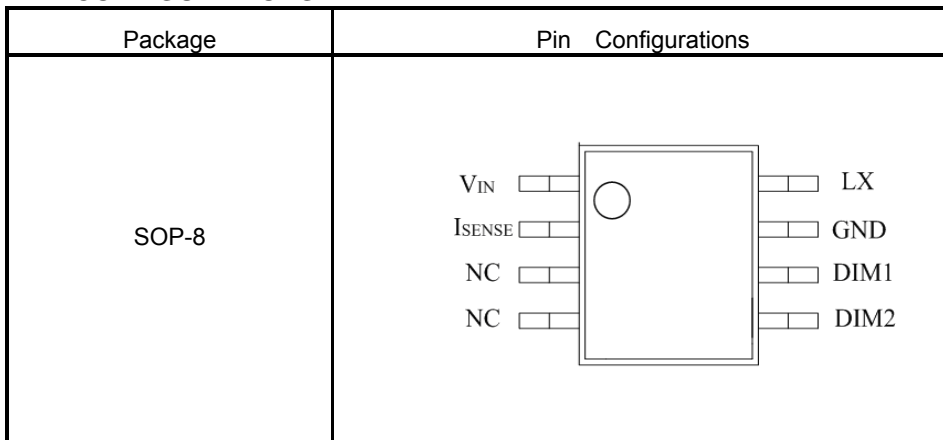

Figure 1-B

PIN CONFIGURATIONS



PIN DESCRIPTION

Pin Name	NO.	Description
V _{IN}	1	Input voltage (8.5V to 40V). Decouple to ground with 0.1μF X7R ceramic capacitor close to device. While using the switch dimming function, connect a 220Uf or higher capacitor close the device.
I _{SENSE}	2	Connect resistor R _S from this pin to V _{IN} to define nominal average output current I _{OUTnom} = 0.1/R _S
DIM1	6	Set the current-levels number of and current ratio of each level of switch dimming function as below: DIM1="floating" DIM2="floating", not dimming;
DIM2	5	DIM1="floating" DIM2="GND", three-levels, 100%---50%---20%; DIM1="GND" DIM2="floating", three-levels, 100%---60%---30%; DIM1="GND" DIM2="GND", two-levels, 100%---30%.
GND	7	Ground (0V)
LX	8	Drain of power switch
NC	3,4	Not connect. Float required

ORDERING INFORMATION

Industrial Range: -40°C to 105°C

Order Number	Package	QTY/Reel
IS31LT3380-GRLS3-TR	SOP-8, Lead-free	2500

IS31LT3380

ABSOLUTE MAXIMUM RATINGS (NOTE1)

Symbol	Parameter	Rating
V_{IN}	Input voltage	-0.3V to +50V
V_{ISENSE}	I_{SENSE} voltage	$V_{in}+0.3V$ to $V_{in}-5V$, $V_{in}>5V$
		$V_{in}+0.3V$ to $-0.3V$, $V_{in}<5V$
V_{LX}	LX output voltage	-0.3V to +50V
V_{DIM}	DIM1 ,DIM2 pin input voltage	-0.3V to +6V
I_{LX}	Switch output current	1.5A
P_{tot}	Power dissipation	0.5W
T_{OP}	Operating temperature	-40 °C to 105°C
T_{ST}	Storage temperature	-55 to 150°C
T_{jMAX}	Junction temperature	150°C
$R_{\theta JA}$	Junction to ambient	100°C/W
	ESD Rating (HBM)	3kV

ELECTRICAL CHARACTERISTICS

($V_{IN}=12V$, $T_A=25^\circ C$ unless otherwise stated) (NOTE 2)

Symbol	Parameter	Conditions	Min.	Typ.	Max.	Unit
V_{IN}	Input voltage		8.5		40	V
I_{INQoff}	Quiescent supply current with output off		70	120	140	μA
I_{INQon}	Quiescent supply current with output switching			450	600	μA
V_{ISENSE}	Mean current sense threshold voltage		95	100	105	mV
UVLO	Undervoltage lockout threshold	V_{IN} falling	5.05	5.85	6.65	V
$\Delta UVLO$	Undervoltage lockout hysteresis			1.65		V
$V_{SENSEHYS}$	Sense threshold hysteresis			± 15		%
I_{SENSE}	I_{SENSE} pin input current	$V_{SENSE} = V_{IN} - 0.1$		8		μA
T_s	the interval time between the external switch action			2		S
Kmode1	In dimming mode 1, the ratio of different output current level to the initial current (DIM1="floating" DIM2="GND")	Level 1		100%		
		Level 2		50%		
		Level 3	17%	20%	23%	

ELECTRICAL CHARACTERISTICS(V_{IN}=12V, TA=25°C unless otherwise stated) (NOTE 2) (continued)

Symbol	Parameter	Conditions	Min.	Typ.	Max.	Unit
Kmode2	In dimming mode 2, the ratio of different output current level to the initial current (DIM1="GND" DIM2="floating")	Level 1		100%		
		Level 2		60%		
		Level 3	28%	30%	32%	
Kmode3	In dimming mode 3, the ratio of different output current level to the initial current (DIM1="GND" DIM2="GND")	Level 1		100%		
		Level 2	28%	30%	32%	
I _{LXmean}	Continuous LX switch current			1.2		A
I _{LX(leak)}	LX switch leakage current				1	μA
R _{LX}	LX Switch 'On' resistance			0.3	0.4	Ω
T _{ONmin}	Minimum switch 'ON' time	LX switch 'ON'		200		ns
T _{OFFmin}	Minimum switch 'OFF' time	LX switch 'OFF'		200		ns
f _{LXmax}	Recommended maximum operating frequency				1	MHz
T _{PD}	Internal comparator propagation delay			25		ns
T _{SD}	Thermal shutdown temperature			150		°C
T _{SD-HYS}	Thermal shutdown hysteresis			20		°C

NOTES:

1. Work beyond maximum absolute voltage and current will cause permanent damage to the device. Long time working under absolute conditions will lower the reliability of the dice.
2. Production testing of the chip is performed at 25°C. Functional operation of the chip and parameters specified are guaranteed by design, characterization and process control in other temperature.

IS31LT3380

TYPICAL OPERATING CONDITIONS

For typical application circuit and $T_A=25^\circ\text{C}$ unless otherwise stated.

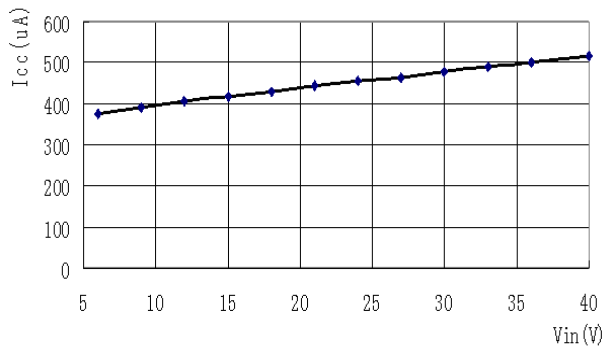

Supply Current vs. V_{in} (Operating)

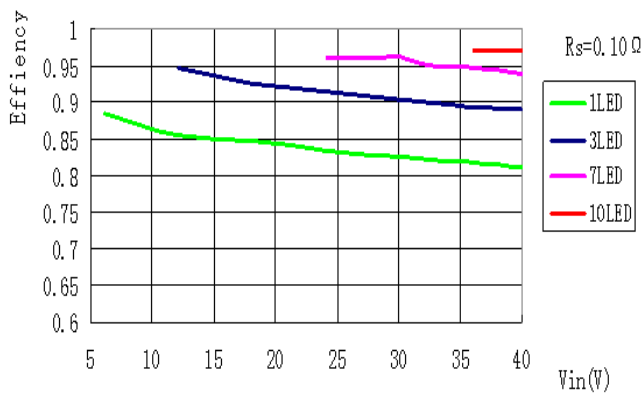

Efficiency vs. No. of LEDs
 $L=47\mu\text{H}$, $R_s=0.10\text{Ohm}$

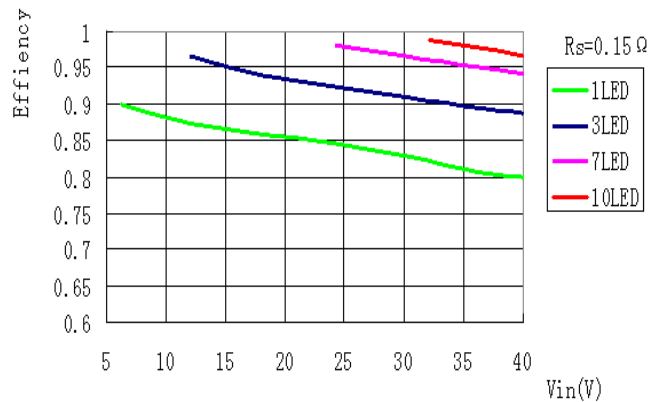

Efficiency vs. No. of LEDs
 $L=47\mu\text{H}$, $R_s=0.15\text{Ohm}$

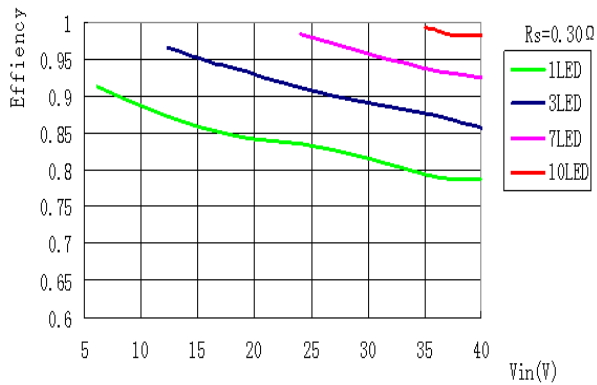

Efficiency vs. No. of LEDs
 $L=47\mu\text{H}$, $R_s=0.30\text{Ohm}$

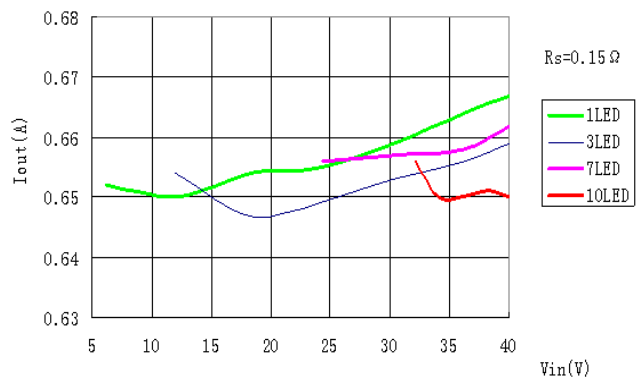

Output current variation with output Voltage
 $L=47\mu\text{H}$, $R_s=0.15\text{Ohm}$

IS31LT3380

TYPICAL OPERATING CONDITIONS

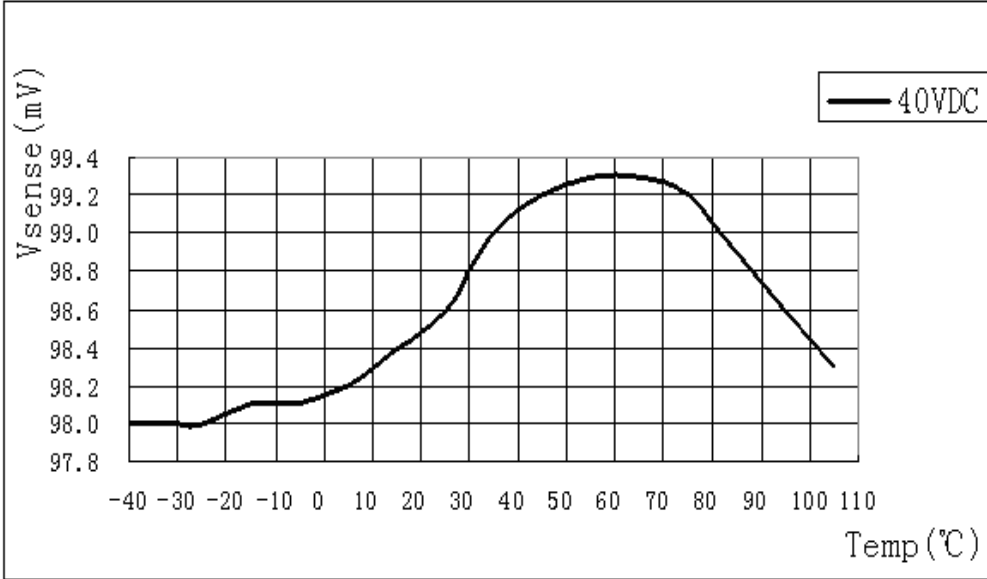

Temperature VS Vsense voltage
 L=47uH, Rs=0.10Ohm

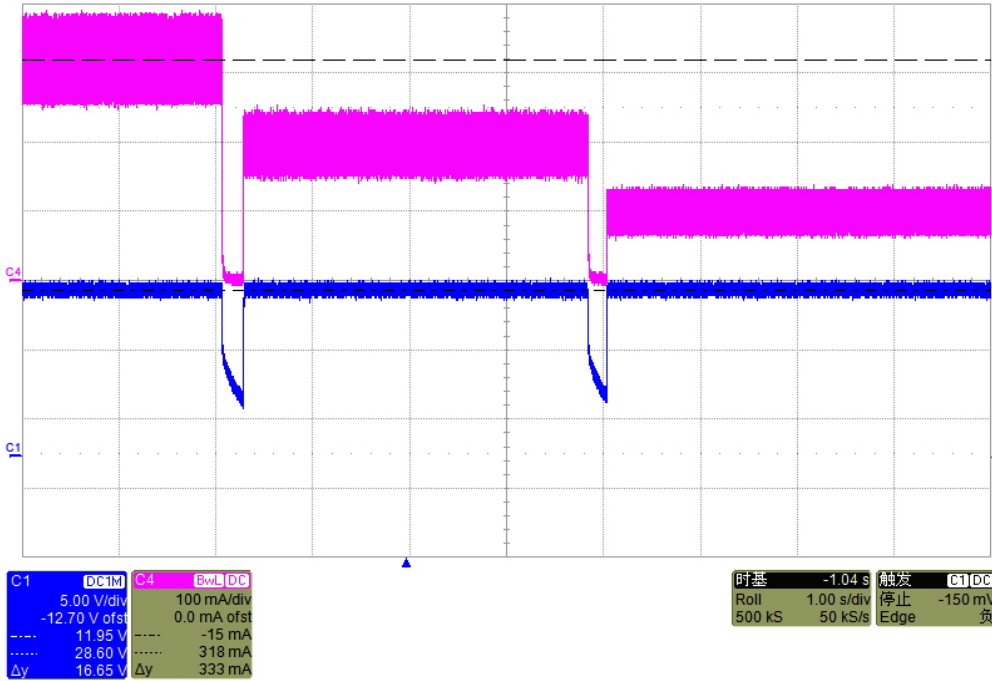

IS31LT3380

SWITCH DIMMING WAVEFORM

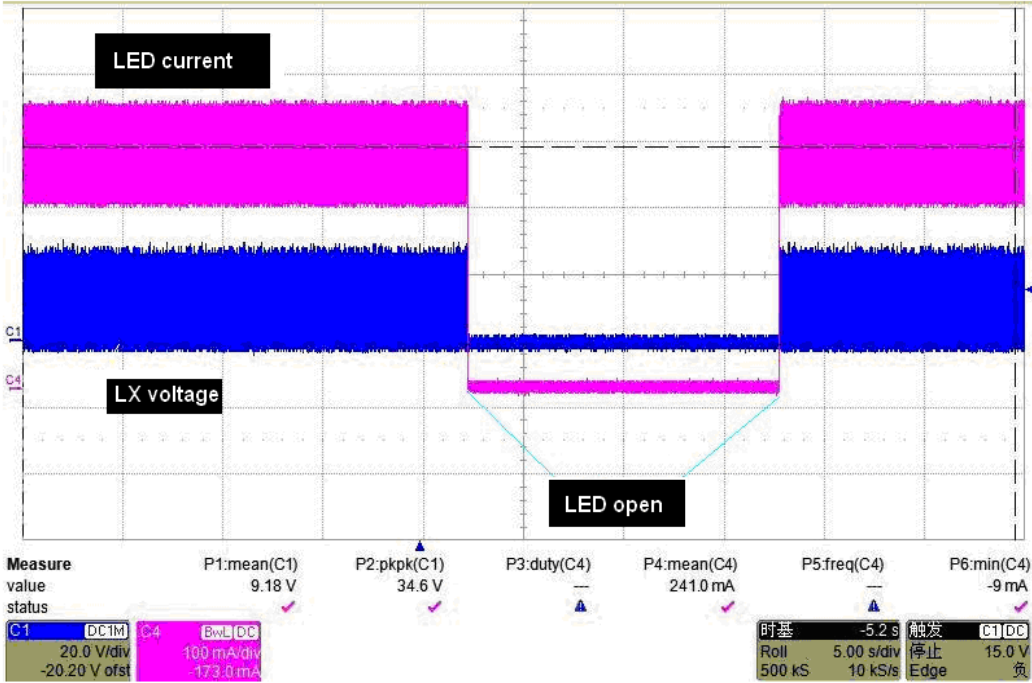

LED open waveform

Vin=24VDC, L=47uH, Rs=0.30Ohm

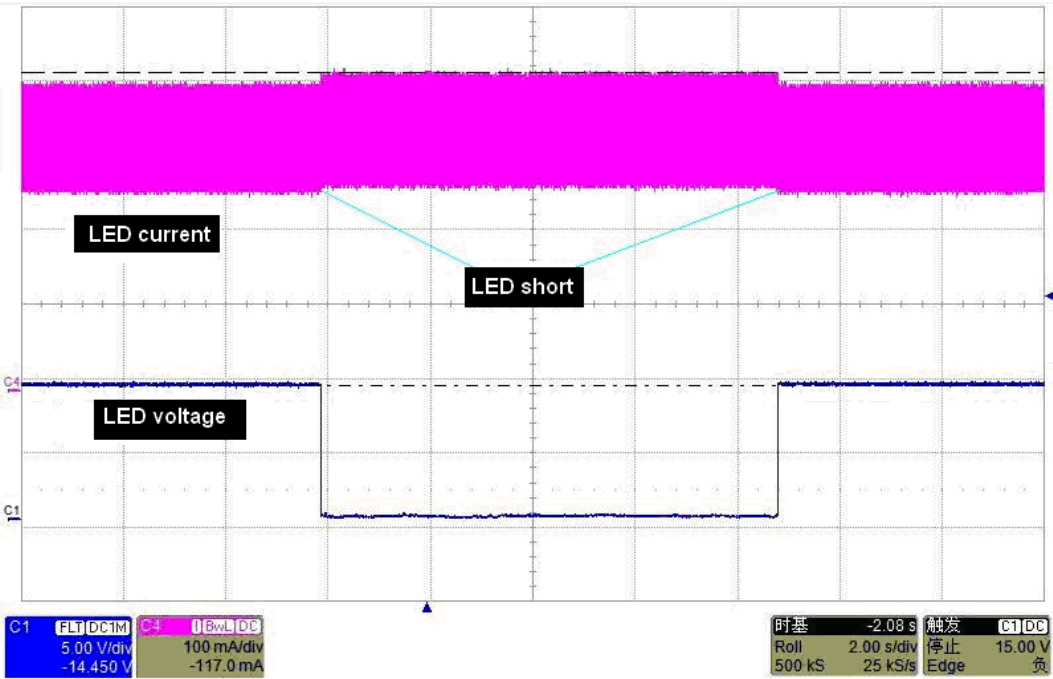

LED short waveform

Vin=24VDC, L=47uH, Rs=0.30Ohm

IS31LT3380

APPLICATION INFORMATION

Setting nominal average output current with external resistor R_s

The nominal average output current in the LED(s) is determined by the value of the external current sense resistor (R_s) connected between V_{IN} and I_{SENSE} and is given by:

$$I_{OUT\ nom} = 0.1/R_s$$

The table below gives values of nominal average output current for several preferred values of current setting resistor (R_s) in the typical application circuit shown on page 2:

R_s (Ω)	Nominal average output current (mA)
0.082	1200
0.15	667
0.3	333

The resistance tolerance of R_s should be 1%, and the power rating must be high enough to continuously handle the average output current. Good over-temperature performance of the resistor is also recommended.

Multi-modes Switch dimming

The IS31LT3380 detects external switch action to adjust output current.

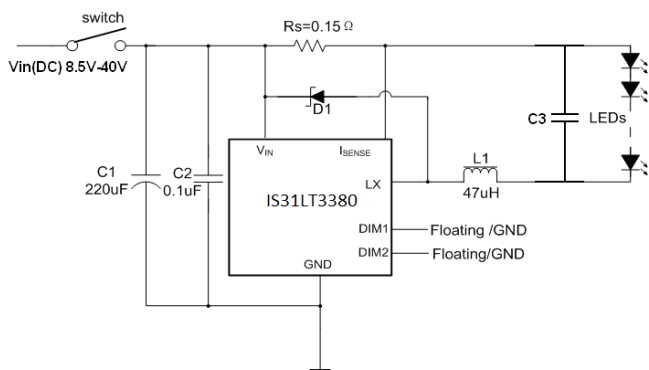

There are two types of switch action: a normal switch, which means the off-time between each subsequent switching is longer than 2s; and a dimming-switching, which means the off-time between each subsequent switch actions is less than 2s.

The nominal average output current is given by:

$$I_{OUT} = K \cdot 0.1/R_s \text{ [K is the current ratio to initial current]}$$

The input condition of the DIM1 and DIM2 pins set the number of current-levels and current ratio for the switch dimming function as shown below:

DIM1	DIM2	Dim-ratio
floating	floating	Not dimming
floating	GND	100%---50%---20%---100%
GND	floating	100%---60%---30%---100%
GND	GND	100%---30%---100%

For instance, suppose the DIM1 pin is floating and the DIM2 pin is connected to GND. The first time the switch is turned on, the initial current is $I_{OUT\ nom}$. After the 1st dimming-switch, $I_{OUT(1)} = 50\% * I_{OUT\ nom}$; After the 2nd dimming-switch, $I_{OUT(2)} = 20\% * I_{OUT\ nom}$; After the 3rd dimming-switch, $I_{OUT(3)} = 100\% * I_{OUT\ nom}$; This process recycles.

If a normal-switch is detected or DIM1 and DIM2 are both floating, the output current goes back to the initial state of 100%.

Since the chip needs to count the time for more than 2 seconds after the switch is OFF, during the OFF time one capacitor bigger than 220uF is required to keep the chip work in low quiescent current mode.

Inherent open-circuit LED protection

If the connection to the LED(s) is open-circuited, the circuit is open, so the chip will not be damaged, unlike in many boost converters, where the back EMF may damage the internal switch by forcing the drain above its breakdown voltage.

Capacitor selection

A low ESR capacitor should be used for input decoupling, as the ESR of this capacitor appears in series with the supply source impedance and lowers overall efficiency. This capacitor has to supply the relatively high peak current to the coil and smooth the current ripple on the input supply.

If the source is a DC supply, the capacitor is decided by ripple of the source, the value is given by:

$$C_{min} = \frac{I_F * T_{on}}{\Delta U_{MAX}}$$

I_F is the value of output current, ΔU_{MAX} is the ripple of power supply. T_{on} is the "ON" time of the MOSFET, normally set at about twice the "OFF" time.

If the source is an AC supply, the output voltage ripple from a nominal 12V AC transformer can be $\pm 10\%$. If the input capacitor value is lower than 200uF, the AC input waveform will be distorted, and sometimes the lowest input voltage can be lower than the forward voltage of the LED strings. This lowers the average current of the

IS31LT3380

LEDs. Therefore, it is recommended to select the value of the capacitor bigger than 200uF.

For maximum stability over temperature and voltage, capacitors with X7R, X5R, or better dielectric are recommended. Capacitors with Y5V dielectric are not suitable for decoupling in this application and should not be used.

Inductor selection

Recommended inductor values for the IS31LT3380 are in the range of 47µH to 220µH.

Higher values of inductance are recommended at higher supply voltages and low output current in order to minimize errors due to switching delays, which result in increased ripple and lower efficiency. Higher values of inductance also result in a smaller change in output current over the supply voltage range. The inductor should be mounted as close to the chip as possible with low resistance connections to the LX and V_{IN} pins. The chosen coil should have a saturation current higher than the peak output current and a continuous current rating above the required mean output current. It is recommended to use inductor with saturation current bigger than 1.2A for 700mA output current and inductor with saturation current bigger than 500mA for 350mA output current, etc.

The inductor value should be chosen to maintain operating duty cycle and switch 'on/off' times within the specified limits over the supply voltage and load current range.

The following equations can be used as a guide.

LX Switch 'On' time

$$T_{ON} = \frac{L\Delta I}{V_{IN} - V_{LED} - I_{AVG}(R_S + rL + R_{LX})}$$

Note: T_{ONmin}>200ns

LX Switch 'Off' time

$$T_{OFF} = \frac{L\Delta I}{V_{LED} + V_D + I_{AVG}(rL + R_S)}$$

Note: T_{OFFmin}>200ns

Where:

L is the coil inductance (H)

r_L is the coil resistance (Ω)

I_{avg} is the required LED current (A)

ΔI is the coil peak-peak ripple current (A) {Internally set to 0.3 × I_{avg}}

V_{IN} is the supply voltage (V)

V_{LED} is the total LED forward voltage (V)

R_{LX} is the switch resistance (Ω)

V_D is the diode forward voltage at the required load current (V)

Example:

For V_{IN}=12V, L=47µH, r_L=0.26Ω, V_{LED}=3.4V, I_{avg}=333mA and V_D=0.36V, R_{LX}=0.27Ω

T_{ON} = (47e-6 × 0.105)/(12 - 3.4 - 0.274) = 0.59µs

T_{OFF} = (47e-6 × 0.105)/(3.4 + 0.36 + 0.188) = 1.25µs

This gives an operating frequency of 543kHz and a duty cycle of 0.32

Optimum performance will be achieved by setting the duty cycle close to 0.5 at the nominal supply voltage. This helps to equalize the undershoot and overshoot and improves temperature stability of the output current.

Diode selection

For maximum efficiency and performance, the rectifier (D1) should be a fast low capacitance Schottky diode with low reverse leakage at the maximum operating voltage and temperature.

If alternative diodes are used, it is important to select parts with a peak current rating above the peak coil current and a continuous current rating higher than the maximum output load current. It is very important to consider the reverse leakage of the diode when operating above 85°C. Excess leakage will increase the power dissipation in the device.

The higher forward voltage and overshoot due to reverse recovery time in silicon diodes will increase the peak voltage on the LX output. If a silicon diode is used, care should be taken to ensure that the total voltage appearing on the LX pin including supply ripple, does not exceed the specified maximum value.

Reducing output ripple

Peak to peak ripple current in the LED can be reduced, if required, by shunting a capacitor C3 across the LED(s) as shown below:

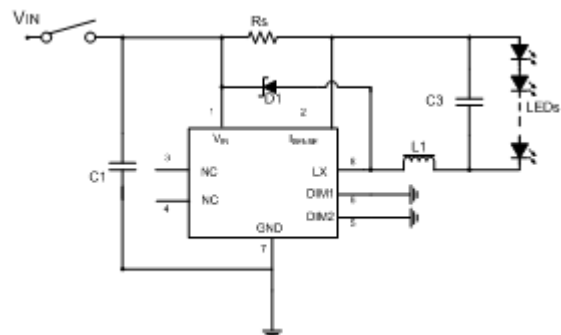

A C3 value of 1µF will reduce nominal ripple current by a factor of approximately three. Proportionally lower ripple can be achieved with higher capacitor values. Note that the capacitor will not affect operating frequency or efficiency, but it will increase start-up delay, by reducing the rate of rise of LED voltage.

IS31LT3380

Thermal considerations

When operating the chip at high ambient temperatures, or when driving maximum load current, care must be taken to avoid exceeding the package power dissipation limits. Note that the chip power dissipation will be a maximum at the minimum supply voltage. It will also increase if the efficiency of the circuit is low. This may result from the use of unsuitable coils, or excessive parasitic output capacitance on the switch output.

Layout considerations

VIN/GND pin

The GND of the power supply usually has some distance between it and the chip GND pin, causing parasitic resistance and inductance, resulting in ground voltage bounce when the MOSFET switches. To minimize ground bounce, the ground pin of the chip should be soldered directly to the ground plane. Connecting a 0.1 μ F capacitor between the VIN and GND pins as close to the chip as possible minimizes the effects of ground bounce.

LX pin

The LX pin of the chip is a fast switching node, so PCB traces should be kept as short as possible.

Coil and decoupling capacitors

It is particularly important to mount the coil and the input decoupling capacitor close to the chip to minimize parasitic resistance and inductance, which will degrade efficiency. It is also important to take account of any trace resistance in series with current sense resistor RS.

DIM pin

The DIM pin is a high impedance input, when it is left floating; this pin is pull up to 3.3V by internal circuit. Avoid running any high voltage traces close to the DIM pins.

IS31LT3380

PACKAGE INFORMATION SOP-8

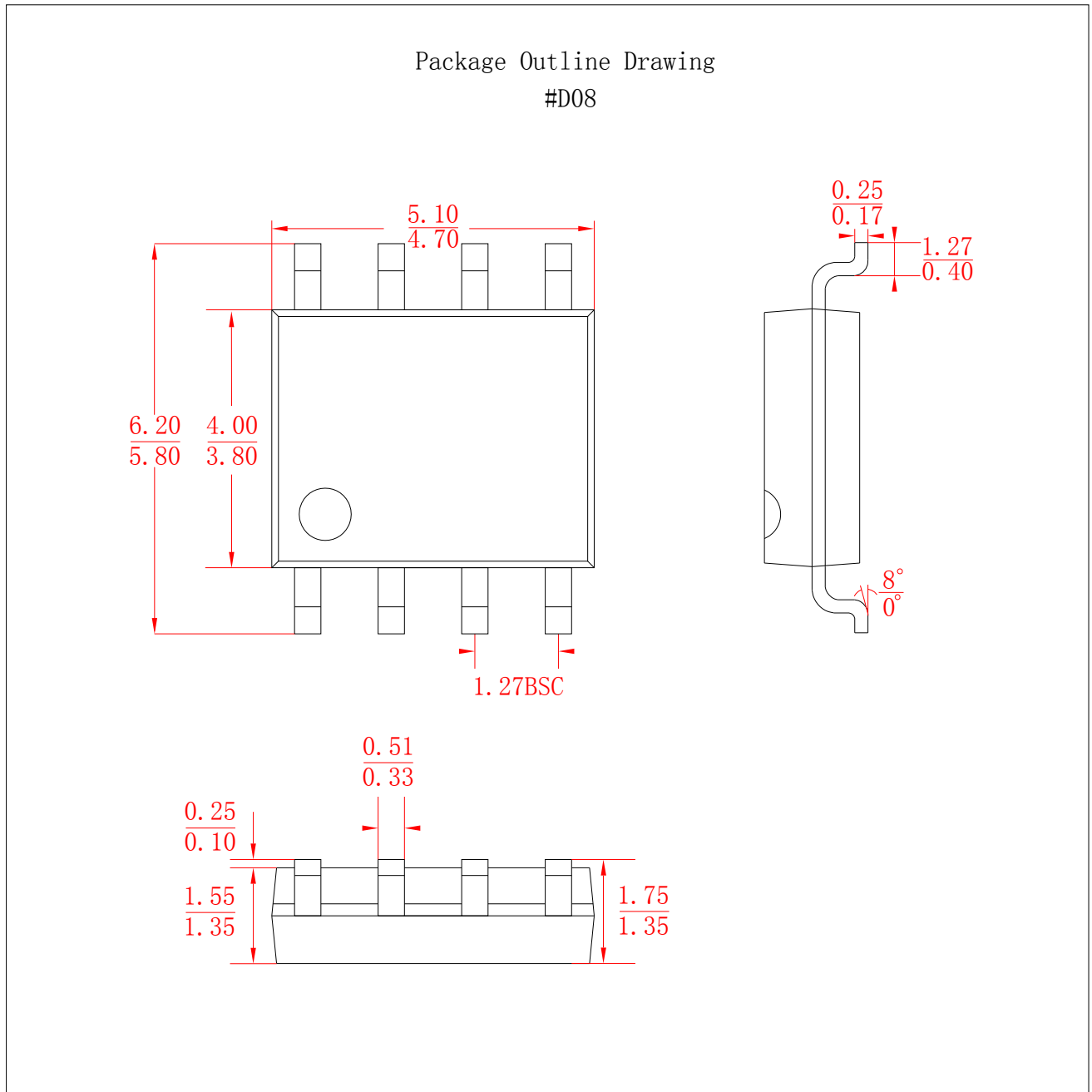

Компания «Океан Электроники» предлагает заключение долгосрочных отношений при поставках импортных электронных компонентов на взаимовыгодных условиях!

Наши преимущества:

- Поставка оригинальных импортных электронных компонентов напрямую с производств Америки, Европы и Азии, а так же с крупнейших складов мира;
- Широкая линейка поставок активных и пассивных импортных электронных компонентов (более 30 млн. наименований);
- Поставка сложных, дефицитных, либо снятых с производства позиций;
- Оперативные сроки поставки под заказ (от 5 рабочих дней);
- Экспресс доставка в любую точку России;
- Помощь Конструкторского Отдела и консультации квалифицированных инженеров;
- Техническая поддержка проекта, помощь в подборе аналогов, поставка прототипов;
- Поставка электронных компонентов под контролем ВП;
- Система менеджмента качества сертифицирована по Международному стандарту ISO 9001;
- При необходимости вся продукция военного и аэрокосмического назначения проходит испытания и сертификацию в лаборатории (по согласованию с заказчиком);
- Поставка специализированных компонентов военного и аэрокосмического уровня качества (Xilinx, Altera, Analog Devices, Intersil, Interpoint, Microsemi, Actel, Aeroflex, Peregrine, VPT, Syfer, Eurofarad, Texas Instruments, MS Kennedy, Miteq, Cobham, E2V, MA-COM, Hittite, Mini-Circuits, General Dynamics и др.);

Компания «Океан Электроники» является официальным дистрибьютором и эксклюзивным представителем в России одного из крупнейших производителей разъемов военного и аэрокосмического назначения «JONHON», а так же официальным дистрибьютором и эксклюзивным представителем в России производителя высокотехнологичных и надежных решений для передачи СВЧ сигналов «FORSTAR».



JONHON

«JONHON» (основан в 1970 г.)

Разъемы специального, военного и аэрокосмического назначения:

(Применяются в военной, авиационной, аэрокосмической, морской, железнодорожной, горно- и нефтедобывающей отраслях промышленности)

«FORSTAR» (основан в 1998 г.)

ВЧ соединители, коаксиальные кабели,
кабельные сборки и микроволновые компоненты:

(Применяются в телекоммуникациях гражданского и специального назначения, в средствах связи, РЛС, а так же военной, авиационной и аэрокосмической отраслях промышленности).



Телефон: 8 (812) 309-75-97 (многоканальный)

Факс: 8 (812) 320-03-32

Электронная почта: ocean@oceanchips.ru

Web: <http://oceanchips.ru/>

Адрес: 198099, г. Санкт-Петербург, ул. Калинина, д. 2, корп. 4, лит. А