

## LT4294, LT4321 IEEE 802.3bt Powered Device

### DESCRIPTION

Demonstration circuit 2583 is an Ethernet Alliance™ certified IEEE 802.3bt compliant Power over Ethernet (PoE) powered device (PD). It features the **LT®4294** PD interface controller and the LT4321 PoE ideal diode bridge controller.

The LT4294 provides IEEE 802.3af (PoE, Type 1), IEEE 802.3at (PoE+, Type 2) and IEEE 802.3bt (PoE++, Type 3 and 4) compliant interfacing. It utilizes an external, low  $R_{DS(ON)}$  (57mΩ typical) N-channel FET for the hot swap function to improve efficiency. Additional features include power good (PWRGD) and  $\overline{T2P}$  output indicators for interfacing with downstream electronics. The PWRGD output indicates the PD controller is ready to provide power to the downstream load. This signal can be used to enable an isolated power supply. The  $\overline{T2P}$  output indicates the available power from the power sourcing

equipment (PSE) to the downstream load. This signal can be used to limit the load and prevent overloading the PSE.

The LT4321 controls eight low  $R_{DS(ON)}$  (57mΩ typical) N-channel FETs to further improve end-to-end power delivery efficiency and ease thermal design. This solution replaces the eight diodes typically found in a passive PoE rectifier bridge.

The DC2583A accepts up to 71.3W of delivered power from a PSE via the RJ45 connector (J1) or a local 48V DC power supply using the auxiliary supply input. When both supplies are connected, the auxiliary supply input has priority over the PoE input.

**Design files for this circuit board are available.**

All registered trademarks and trademarks are the property of their respective owners.

### BOARD PHOTO

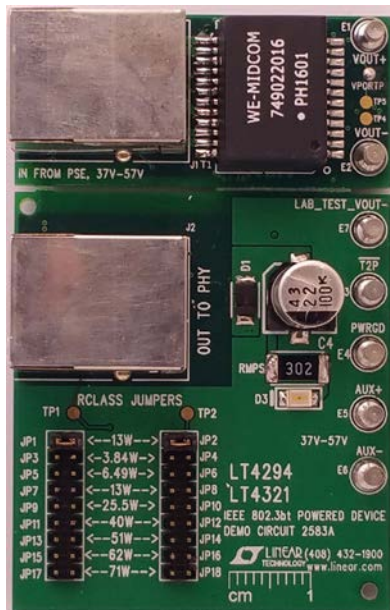

Top Side

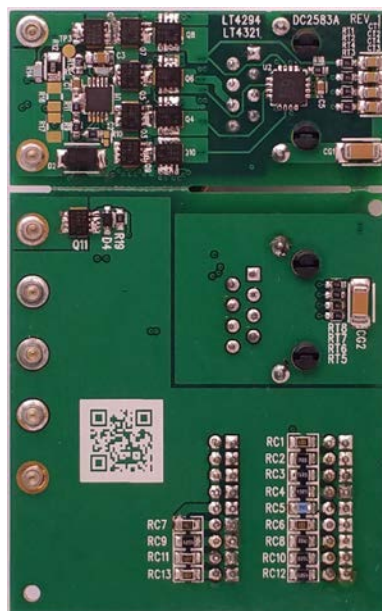

Bottom Side



# DEMO MANUAL DC2583A

## PERFORMANCE SUMMARY Specifications are at $T_A = 25^\circ\text{C}$

PARAMETER	CONDITIONS	MIN	TYP	MAX	UNITS
Port Voltage ( $V_{\text{PORT}}$ )	At RJ45	37		57	V
Auxiliary Voltage	From AUX+ to AUX- Terminals	37		57	V
Efficiency	$V_{\text{PORT}} = 48\text{V}$ , $I_{\text{OUT}} = 1.2\text{A}$		99.2		%
T2P Switching Frequency			840		Hz

## TYPICAL PERFORMANCE CHARACTERISTICS

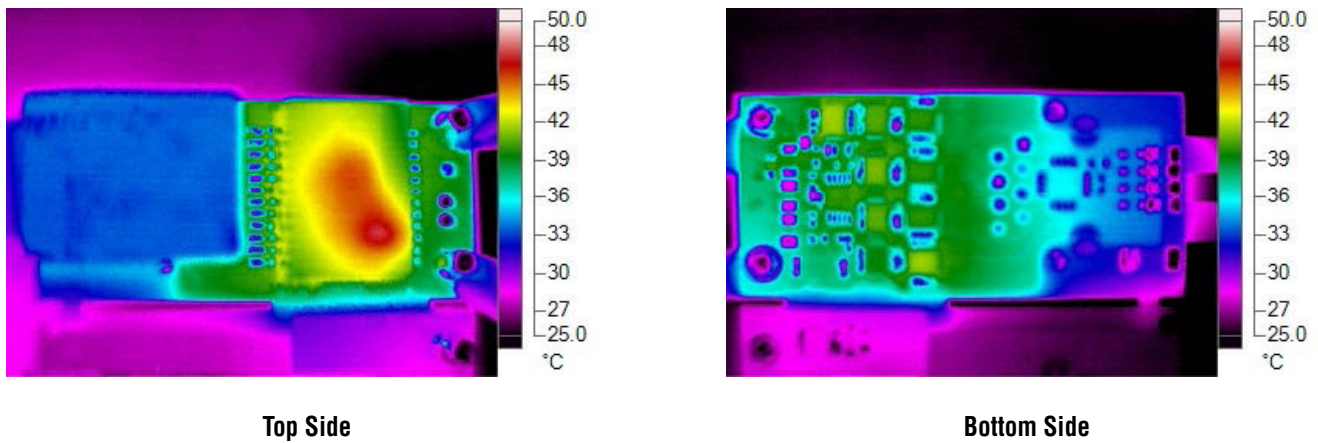

Figure 1. Thermal Pictures (Conditions:  $V_{\text{PORT}} = 41.2\text{V}$ ,  $V_{\text{OUT}} = 40.8\text{V}$ ,  $I_{\text{OUT}} = 1.72\text{A}$ )

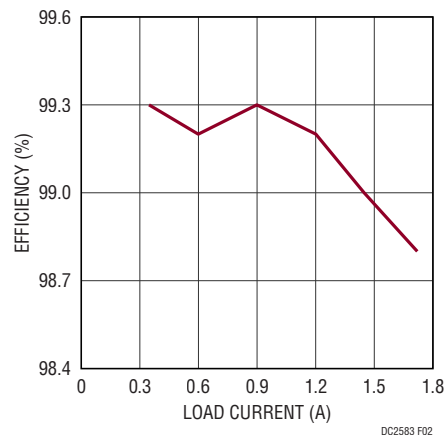

Figure 2. Efficiency (End-to-End)

## QUICK START PROCEDURE

### Power Over Ethernet (PoE) Input

1. Disconnect auxiliary supply if it is connected to AUX+ and AUX– inputs of the DC2583A.
2. Refer to Figure 3 to evaluate the DC2583A with a DC/DC converter. If a resistive or an active load is used to evaluate the DC2583A, use the setup diagram as shown in Figure 4.
3. Default class shunt positions are at JP1 and JP2 on the DC2583A board. Choose a power level from Table 1 and select the corresponding shunt positions.

**Table 1. Single-Signature Classification Codes, Power Levels and Jumper Selection**

PD CLASS	ALLOCATED CLASS POWER AT THE PD INPUT	RCLASS JUMPERS	
0*	13W	JP1	JP2
1	3.84W	JP3	JP4
2	6.49W	JP5	JP6
3	13W	JP7	JP8
4	25.5W	JP9	JP10
5	40W	JP11	JP12
6	51W	JP13	JP14
7	62W	JP15	JP16
8	71W	JP17	JP18

\*Class 0 is not defined for 802.3bt PDs.

4. Connect the output of the IEEE 802.3bt compliant PSE (see note) to the RJ45 connector (J1) of the DC2583A using a CAT5e or CAT6 Ethernet cable.
5. After connection has been established, verify that the LED (D3) is lit. This indicates the PSE has successfully detected and powered the PD.
6. Verify  $\overline{T2P}$  response with a digital multimeter or an oscilloscope. The  $\overline{T2P}$  response for the type of PSE connected to the DC2583A is provided in Table 2.

Note: An 802.3bt PSE has not yet been released. In the interim, an LTPoE++<sup>®</sup> compliant PSE (DC1814A-D) may be used to provide power to the DC2583A. The LTPoE++ classification will not be 802.3bt compliant, but the PSE will provide a compatible detection and power output. Specifically, the  $\overline{T2P}$  output of the DC2583A is different from the behavior stated in Table 2 and will indicate connection to a Type 2 PSE. Otherwise PD behavior will be unaffected.

**Table 2.  $\overline{T2P}$  Response**

PSE	$\overline{T2P}$ RESPONSE	NEGOTIATED PD INPUT POWER
IEEE	Logic High	13W
	Logic Low	25.5W
	50% Logic High/50% Logic Low, Toggle at 840Hz (typical)	51W
	75% Logic High/25% Logic Low, Toggle at 840Hz (typical)	71W
LTPoE++, 90W	Logic Low	71W

## QUICK START PROCEDURE

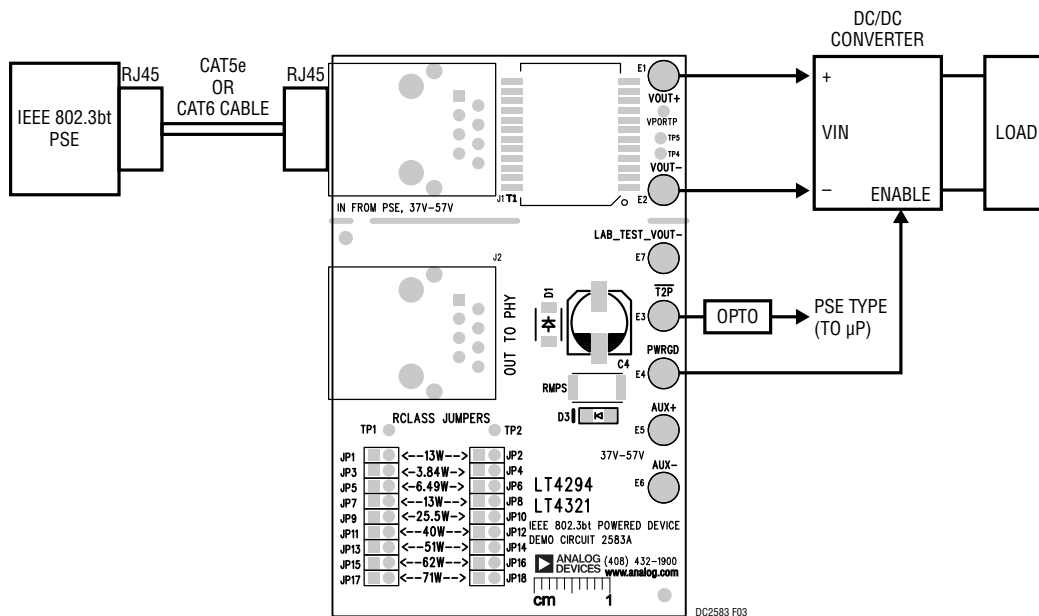

Figure 3. Setup Diagram for DC2583A with a DC/DC Converter, a Microprocessor and an IEEE 802.3bt PSE

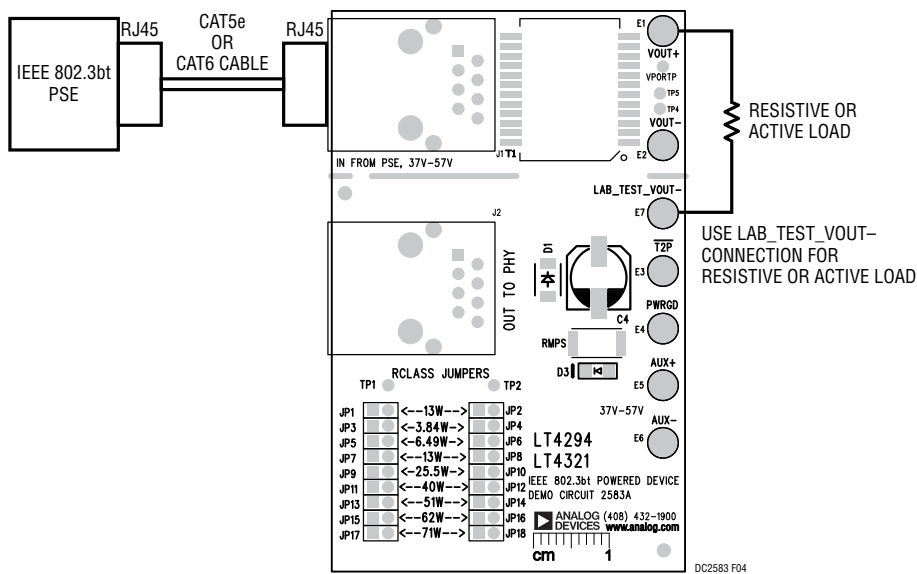

Figure 4. Setup Diagram for DC2583A with a Resistive or an Active Load

## QUICK START PROCEDURE

### Auxiliary Supply Input

1. Place and connect test equipment as shown in Figure 5.
2. Turn down the electronic load to a minimum value and turn off the electronic load.
3. Connect the output of the auxiliary supply to the DC2583A as shown in Figure 5. Turn on the auxiliary supply and set its current limit to 2A. Then increase its output voltage to 48V.

4. Once the LED (D3) on the DC2583A is lit, check the output voltage using a voltmeter. Output voltage should be within 37-57V.
5. Verify  $\overline{T2P}$  response with an oscilloscope as shown in Figure 5. The  $\overline{T2P}$  response during auxiliary power operation is provided in Table 3.

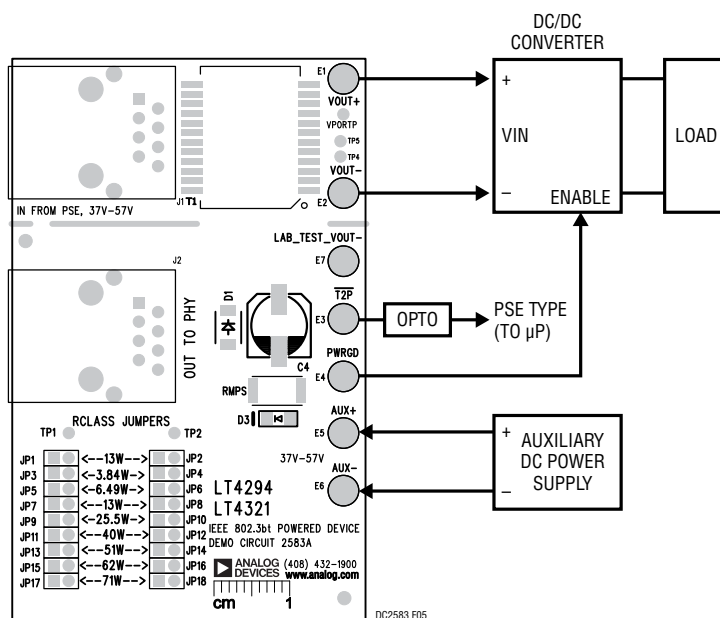

Figure 5. Setup Diagram for Auxiliary Supply Input

Table 3.  $\overline{T2P}$  Response During Auxiliary Power Operation

PD CLASS	$\overline{T2P}$ RESPONSE
0-4	Logic Low
5-8	75% Logic High/25% Logic Low, Toggle at 840Hz (typical)

# DEMO MANUAL DC2583A

## PARTS LIST

ITEM	QTY	REFERENCE	PART DESCRIPTION	MANUFACTURER/PART NUMBER
<b>Required Circuit Components</b>				
1	2	C1, C5	CAP, 0.047 $\mu$ F, X7S, 100V, 10%, 0603	TDK, C1608X7S2A473K080AB
2	0	C2	CAP, OPTION, 0402	OPT
3	1	C3	CAP, 0.047 $\mu$ F, X7R, 100V, 10%, 0805	AVX, 08051C473KAT2A
4	1	CG1	CAP, 1000pF, X7R, 2000V, 10%, 1808	TDK, C4520X7R3D102K130KA
5	4	CT1, CT2, CT3, CT4	CAP, CER, X7R 0.01 $\mu$ F 200V 10%, 0805	AVX, 08052C103KAZ2A
6	1	D2	DIODE, TVS, 58V, 600W, SOD128	NEXPERIA, PTVS58VP1UTP
7	1	D1	DIODE, SCHOTTKY, 100V, 3A	NEXPERIA, PMEG10030
8	1	J1	CONN., MOD. JACK, FEMALE, 2.54mm, 8 TERMINAL, 1 PORT, R/A THRU-HOLE	STEWART CONNECTOR, SS-7188S-A-NF
9	2	Q1, Q11	MOSFET, N-CH, 100V, 36.6m $\Omega$ , 30A, 91W, LFPAK33	NEXPERIA, PSMN040-100MSE
10	8	Q3, Q4, Q5, Q6, Q7, Q8, Q9, Q10	MOSFET, N-CH, 100V, 71m $\Omega$ , 18A, 65W, LFPAK33	NEXPERIA, PSMN075-100MSE
11	1	R9	RES., 174k, 1%, 0603	NIC, NRC06F1743TRF
12	1	R10	RES., 52.3k, 1%, 0603	NIC, NRC06F5232TRF
13	2	R11, R18	RES., 0 $\Omega$ , 1/10W, 0603	VISHAY, CRCW06030000Z0EA
14	1	R12	RES., 8.2 $\Omega$ , 1/5W, 5%, 0805	NIC, NRC10J8R2TRF
15	1	R13	RES., 3.3k, 1/10W, 5%, 0603	VISHAY, CRCW06033K30JNEA
16	2	R14, R15	RES., 100k, 1/10W, 5%, 0603	VISHAY, CRCW0603100KJNEA
17	0	R16, R17	RES., OPT, 0805	OPT
18	2	RC1, RC6	RES., 1.00k, 1/8W, 1%, 0805	VISHAY, CRCW08051K00FKEA
19	2	RC2, RC8	RES., 140 $\Omega$ , 1/8W, 1%, 0805	VISHAY, CRCW0805140RFKEA
20	2	RC3, RC10	RES., 76.8 $\Omega$ , 1/8W, 1%, 0805	VISHAY, CRCW080576R8FKEA
21	2	RC4, RC12	RES., 49.9 $\Omega$ , 1/8W, 1%, 0805	VISHAY, CRCW080549R9FKEA
22	1	RC5	RES., 34.8 $\Omega$ , 1/8W, 1%, 0805	VISHAY, CRCW080534R8FKEA
23	1	RC7	RES., 37.4 $\Omega$ , 1/8W, 1%, 0805	VISHAY, CRCW080537R4FKEA
24	1	RC9	RES., 46.4 $\Omega$ , 1/8W, 1%, 0805	PANASONIC, ERJ-6ENF46R4V
25	1	RC11	RES., 64.9 $\Omega$ , 1/8W, 1%, 0805	VISHAY, CRCW080564R9FKEA
26	1	RC13	RES., 118 $\Omega$ , 1/8W, 1%, 0805	VISHAY, CRCW0805118RFKEA
27	4	RT1, RT2, RT3, RT4	RES., 75 $\Omega$ , 1/10W, 5%, 0603	VISHAY, CRCW060375R0JNEA
28	1	T1	TRANSFORMER, ETHERNET, 749022016	WURTH ELEKTRONIK, 749022016
29	0	T4 (ALTERNATE)	TRANSFORMER, ETHERNET, EPG4260S-LF	PCA EPG4260S-LF
30	0	T4 (ALTERNATE)	TRANSFORMER, ETHERNET, ETH1-460LD	COILCRAFT ETH1-460LD
31	1	U1	I.C., IEEE 802.3bt PD CONTROLLERS, DFN10, 3mm x 3mm	ANALOG DEVICES, LT4294IDD#PBF
32	1	U2	I.C., PoE IDEAL DIODE BRIDGE CONTROLLER, QFN16-UF, 4mm x 4mm	ANALOG DEVICES, LT4321IUF#PBF

## PARTS LIST

ITEM	QTY	REFERENCE	PART DESCRIPTION	MANUFACTURER/PART NUMBER
<b>Hardware: For Demo Board Only</b>				
1	1	C4	CAP, ALUM. ELECT, 22 $\mu$ F, 100V, 20%	SUN ELECTRONIC, 100CE22BS
2	1	CG2	CAP, 1000pF, X7R, 2000V, 10%, 1808	TDK, C4520X7R3D102K130KA
3	1	D3	LED, GREEN, 560nm, 3x2mm, 1206	ROHM, SML-010FTT86L
4	1	D4	DIODE, 12V, 200mW, SOD-323	DIODES INC, MMSZ5242BS-7-F
5	7	E1, E2, E3, E4, E5, E6, E7	TURRET, 0.094" MTG. HOLE	MILL-MAX 2501-2-00-80-00-00-07-0
6	1	J2	CONN., MOD. JACK, FEMALE, 2.54mm, 8 TERMINAL, 1 PORT, R/A THRU-HOLE	STEWART CONNECTOR, SS-7188S-A-NF
7	18	JP1-JP18	CONN., HEADER, 1X2, 2mm	SULLINS, NRPN021PAEN-RC
8	1	R19	RES., 30k, 1/10W, 5%, 0603	VISHAY, CRCW060330K0JNEA
9	1	RMPS1	RES., 3.0k, 2W, 1%, 2512	TE CONNECTIVITY 35213K0FT
10	4	RT5, RT6, RT7, RT8	RES., 75 $\Omega$ , 1/10W, 5%, 0603	VISHAY, CRCW060375R0JNEA
11	2	XJP1, XJP2	SHUNT, 2mm	SAMTEC, 2SN-BK-G
12	1		PCB, DC2583A	DEMO CIRCUIT 2583A
13	2		STENCILS, DC2583A (TOP & BOTTOM)	STENCIL DC22583A

# DEMO MANUAL DC2583A

## SCHEMATIC DIAGRAM

REVISION HISTORY		APPROVED	DATE
ECO	REV	DESCRIPTION	
—	1	PRODUCTION	KAUNG H. 05-24-17

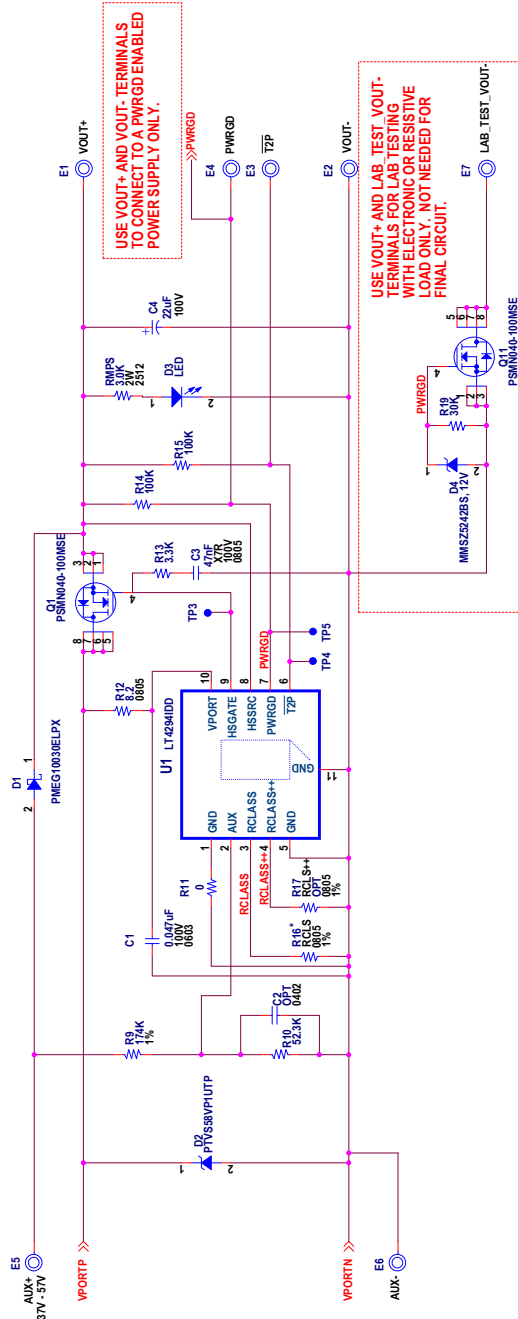
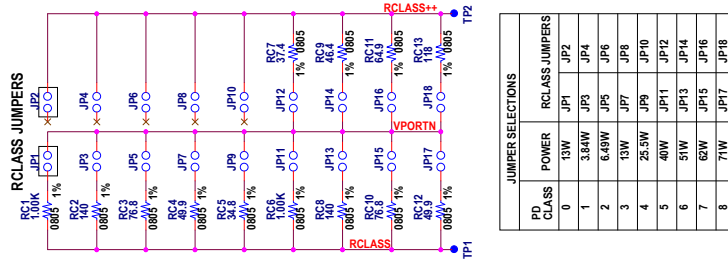

USE VOUT+ AND VOUT- TERMINALS TO CONNECT TO A PWRGD ENABLED POWER SUPPLY ONLY.

USE VOUT+ AND LAB\_TEST\_VOUT- TERMINALS FOR LAB TESTING WITH ELECTRONIC OR RESISTIVE LOAD ONLY. NOT NEEDED FOR FINAL CIRCUIT.

**CUSTOMER NOTICE**  
 LINEAR TECHNOLOGY HAS MADE A BEST EFFORT TO DESIGN A BOARD LAYOUT FOR THE DC2583A DEMO MANUAL. HOWEVER, IT REMAINS THE CUSTOMER'S RESPONSIBILITY TO VERIFY THE BOARD LAYOUT FOR THEIR SPECIFIC APPLICATION. COMPONENT SUBSTITUTION AND PRINTED CIRCUIT BOARD LAYOUT MAY SIGNIFICANTLY AFFECT CIRCUIT PERFORMANCE. LINEAR TECHNOLOGY ACCEPTS NO LIABILITY FOR ASSURANCE TECHNOLOGY APPLICATIONS ENGINEERING FOR ASSURANCE.

**APPROVALS**

PCB DES.	KAUNG H.
APP'G	KAUNG H.

**ANALOG DEVICES**  
 1680 McCarthy Blvd.  
 Milpitas, CA 95035  
 Phone: (408)321-1900 www.linear.com  
 Fax: (408)321-0001  
 © 2017 Analog Devices, Inc. All Rights Reserved.  
 LTC Confidential For Customer Use Only

**IEEE 802.3bt POWERED DEVICE**

SIZE	IC NO.	REV.
N/A	LT4294IDD, LT4321UUF	1

THIS CIRCUIT IS PROPRIETARY TO LINEAR TECHNOLOGY AND SUPPLIED FOR USE WITH LINEAR TECHNOLOGY PARTS.

DATE: Wednesday, May 24, 2017

SHEET 1 OF 2

**NOTE 1: UNLESS OTHERWISE SPECIFIED**  
 1. ALL RESISTORS AND CAPACITORS ARE 0805  
 2. ALL RESISTORS TOLERANCE RATING ARE 5%



**SCHEMATIC DIAGRAM**

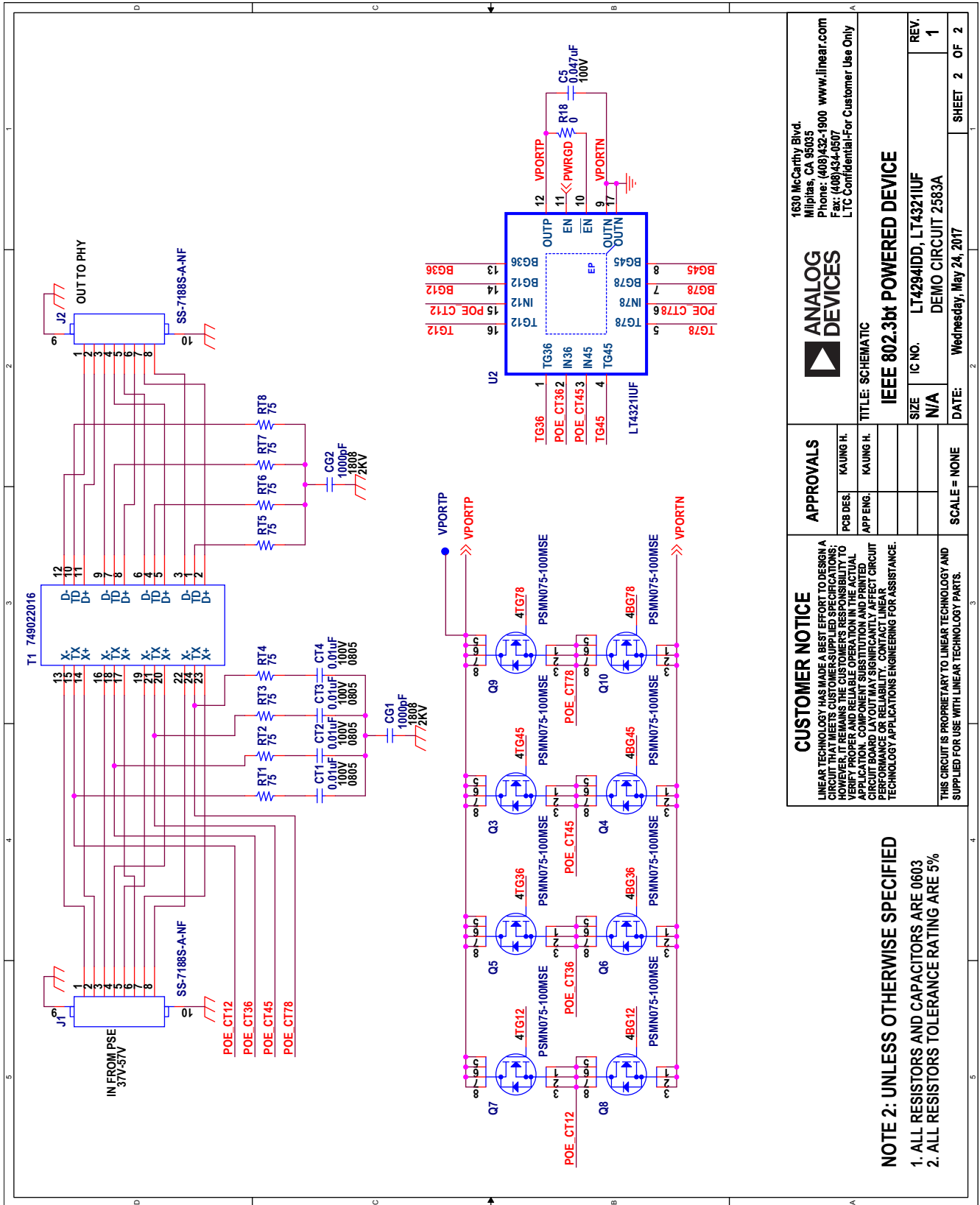

		1630 McCarthy Blvd. Milpitas, CA 95035 Phone: (408)432-1900 www.linear.com Fax: (408)434-4507 LTC Confidential-For Customer Use Only	
<b>APPROVALS</b>		<b>TITLE: SCHEMATIC</b>	
PCB DES. KAUNG H.	APP ENG. KAUNG H.	<b>IEEE 802.3bt POWERED DEVICE</b>	
SIZE N/A	IC NO. LT4294IDD, LT4321IUF	REV. 1	SHEET 2 OF 2
<b>CUSTOMER NOTICE</b> LINEAR TECHNOLOGY HAS MADE A BEST EFFORT TO DESIGN A CIRCUIT THAT MEETS CUSTOMER-SUPPLIED SPECIFICATIONS. HOWEVER, IT REMAINS THE CUSTOMER'S RESPONSIBILITY TO VERIFY PROPER AND RELIABLE OPERATION IN THE ACTUAL APPLICATION. COMPONENT SUBSTITUTION AND PRINTED CIRCUIT BOARD LAYOUT MAY SIGNIFICANTLY AFFECT CIRCUIT TECHNOLOGY APPLICATIONS ENGINEERING FOR ASSISTANCE.		THIS CIRCUIT IS PROPRIETARY TO LINEAR TECHNOLOGY AND SUPPLIED FOR USE WITH LINEAR TECHNOLOGY PARTS.	
<b>NOTE 2: UNLESS OTHERWISE SPECIFIED</b> 1. ALL RESISTORS AND CAPACITORS ARE 0603 2. ALL RESISTORS TOLERANCE RATING ARE 5%		DATE: Wednesday, May 24, 2017	

Information furnished by Analog Devices is believed to be accurate and reliable. However, no responsibility is assumed by Analog Devices for its use, nor for any infringements of patents or other rights of third parties that may result from its use. Specifications subject to change without notice. No license is granted by implication or otherwise under any patent or patent rights of Analog Devices.





## ESD Caution

**ESD (electrostatic discharge) sensitive device.** Charged devices and circuit boards can discharge without detection. Although this product features patented or proprietary protection circuitry, damage may occur on devices subjected to high energy ESD. Therefore, proper ESD precautions should be taken to avoid performance degradation or loss of functionality.

## Legal Terms and Conditions

By using the evaluation board discussed herein (together with any tools, components documentation or support materials, the "Evaluation Board"), you are agreeing to be bound by the terms and conditions set forth below ("Agreement") unless you have purchased the Evaluation Board, in which case the Analog Devices Standard Terms and Conditions of Sale shall govern. Do not use the Evaluation Board until you have read and agreed to the Agreement. Your use of the Evaluation Board shall signify your acceptance of the Agreement. This Agreement is made by and between you ("Customer") and Analog Devices, Inc. ("ADI"), with its principal place of business at One Technology Way, Norwood, MA 02062, USA. Subject to the terms and conditions of the Agreement, ADI hereby grants to Customer a free, limited, personal, temporary, non-exclusive, non-sublicensable, non-transferable license to use the Evaluation Board FOR EVALUATION PURPOSES ONLY. Customer understands and agrees that the Evaluation Board is provided for the sole and exclusive purpose referenced above, and agrees not to use the Evaluation Board for any other purpose. Furthermore, the license granted is expressly made subject to the following additional limitations: Customer shall not (i) rent, lease, display, sell, transfer, assign, sublicense, or distribute the Evaluation Board; and (ii) permit any Third Party to access the Evaluation Board. As used herein, the term "Third Party" includes any entity other than ADI, Customer, their employees, affiliates and in-house consultants. The Evaluation Board is NOT sold to Customer; all rights not expressly granted herein, including ownership of the Evaluation Board, are reserved by ADI. CONFIDENTIALITY. This Agreement and the Evaluation Board shall all be considered the confidential and proprietary information of ADI. Customer may not disclose or transfer any portion of the Evaluation Board to any other party for any reason. Upon discontinuation of use of the Evaluation Board or termination of this Agreement, Customer agrees to promptly return the Evaluation Board to ADI. ADDITIONAL RESTRICTIONS. Customer may not disassemble, decompile or reverse engineer chips on the Evaluation Board. Customer shall inform ADI of any occurred damages or any modifications or alterations it makes to the Evaluation Board, including but not limited to soldering or any other activity that affects the material content of the Evaluation Board. Modifications to the Evaluation Board must comply with applicable law, including but not limited to the RoHS Directive. TERMINATION. ADI may terminate this Agreement at any time upon giving written notice to Customer. Customer agrees to return to ADI the Evaluation Board at that time. LIMITATION OF LIABILITY. THE EVALUATION BOARD PROVIDED HEREUNDER IS PROVIDED "AS IS" AND ADI MAKES NO WARRANTIES OR REPRESENTATIONS OF ANY KIND WITH RESPECT TO IT. ADI SPECIFICALLY DISCLAIMS ANY REPRESENTATIONS, ENDORSEMENTS, GUARANTEES, OR WARRANTIES, EXPRESS OR IMPLIED, RELATED TO THE EVALUATION BOARD INCLUDING, BUT NOT LIMITED TO, THE IMPLIED WARRANTY OF MERCHANTABILITY, TITLE, FITNESS FOR A PARTICULAR PURPOSE OR NON-INFRINGEMENT OF INTELLECTUAL PROPERTY RIGHTS. IN NO EVENT WILL ADI AND ITS LICENSORS BE LIABLE FOR ANY INCIDENTAL, SPECIAL, INDIRECT, OR CONSEQUENTIAL DAMAGES RESULTING FROM CUSTOMER'S POSSESSION OR USE OF THE EVALUATION BOARD, INCLUDING BUT NOT LIMITED TO LOST PROFITS, DELAY COSTS, LABOR COSTS OR LOSS OF GOODWILL. ADI'S TOTAL LIABILITY FROM ANY AND ALL CAUSES SHALL BE LIMITED TO THE AMOUNT OF ONE HUNDRED US DOLLARS (\$100.00). EXPORT. Customer agrees that it will not directly or indirectly export the Evaluation Board to another country, and that it will comply with all applicable United States federal laws and regulations relating to exports. GOVERNING LAW. This Agreement shall be governed by and construed in accordance with the substantive laws of the Commonwealth of Massachusetts (excluding conflict of law rules). Any legal action regarding this Agreement will be heard in the state or federal courts having jurisdiction in Suffolk County, Massachusetts, and Customer hereby submits to the personal jurisdiction and venue of such courts. The United Nations Convention on Contracts for the International Sale of Goods shall not apply to this Agreement and is expressly disclaimed.

Компания «Океан Электроники» предлагает заключение долгосрочных отношений при поставках импортных электронных компонентов на взаимовыгодных условиях!

Наши преимущества:

- Поставка оригинальных импортных электронных компонентов напрямую с производств Америки, Европы и Азии, а так же с крупнейших складов мира;
- Широкая линейка поставок активных и пассивных импортных электронных компонентов (более 30 млн. наименований);
- Поставка сложных, дефицитных, либо снятых с производства позиций;
- Оперативные сроки поставки под заказ (от 5 рабочих дней);
- Экспресс доставка в любую точку России;
- Помощь Конструкторского Отдела и консультации квалифицированных инженеров;
- Техническая поддержка проекта, помощь в подборе аналогов, поставка прототипов;
- Поставка электронных компонентов под контролем ВП;
- Система менеджмента качества сертифицирована по Международному стандарту ISO 9001;
- При необходимости вся продукция военного и аэрокосмического назначения проходит испытания и сертификацию в лаборатории (по согласованию с заказчиком);
- Поставка специализированных компонентов военного и аэрокосмического уровня качества (Xilinx, Altera, Analog Devices, Intersil, Interpoint, Microsemi, Actel, Aeroflex, Peregrine, VPT, Syfer, Eurofarad, Texas Instruments, MS Kennedy, Miteq, Cobham, E2V, MA-COM, Hittite, Mini-Circuits, General Dynamics и др.);

Компания «Океан Электроники» является официальным дистрибьютором и эксклюзивным представителем в России одного из крупнейших производителей разъемов военного и аэрокосмического назначения «JONHON», а так же официальным дистрибьютором и эксклюзивным представителем в России производителя высокотехнологичных и надежных решений для передачи СВЧ сигналов «FORSTAR».



## JONHON

«JONHON» (основан в 1970 г.)

Разъемы специального, военного и аэрокосмического назначения:

(Применяются в военной, авиационной, аэрокосмической, морской, железнодорожной, горно- и нефтедобывающей отраслях промышленности)

«FORSTAR» (основан в 1998 г.)

ВЧ соединители, коаксиальные кабели, кабельные сборки и микроволновые компоненты:

(Применяются в телекоммуникациях гражданского и специального назначения, в средствах связи, РЛС, а так же военной, авиационной и аэрокосмической отраслях промышленности).



Телефон: 8 (812) 309-75-97 (многоканальный)

Факс: 8 (812) 320-03-32

Электронная почта: [ocean@oceanchips.ru](mailto:ocean@oceanchips.ru)

Web: <http://oceanchips.ru/>

Адрес: 198099, г. Санкт-Петербург, ул. Калинина, д. 2, корп. 4, лит. А