

MAX2644

2.4GHz SiGe, High IP3 Low-Noise Amplifier

General Description

The MAX2644 low-cost, high third-order intercept point (IP3) low-noise amplifier (LNA) is designed for applications in 2.4GHz WLAN, ISM, and Bluetooth radio systems. It features a programmable bias, allowing the input IP3 and supply current to be optimized for specific applications. The LNA provides up to +1dBm input IP3 while maintaining a low noise figure of 2.0dB and a typical gain of 16dB.

The MAX2644 is designed on a low-noise, advanced silicon-germanium (SiGe) technology. It operates with a +2.7V to +5.5V single supply and is available in an ultra-small 6-pin SC70 package.

Applications

- Bluetooth
- 802.11 WLAN
- Home RF
- Satellite CD Radio
- 2.4GHz ISM Band Radios
- 2.4GHz Cordless Phones
- Wireless Local Loop (WLL)

Features

- Low Noise Figure (2.0dB at 2450MHz)
- High Gain: 16dB
- Adjustable IP3 and Bias Current
- Low-Power Standby Mode
- On-Chip Output Matching
- +2.7V to +5.5V Single-Supply Operation
- Ultra-Small 6-Pin SC70 Package

Ordering Information

PART	TEMP RANGE	PIN-PACKAGE	TOP MARK
MAX2644EXT+	-40°C to +85°C	6 SC70	AAG
MAX2644EXT-T	-40°C to +85°C	6 SC70	AAG
MAX2644EXT+T	-40°C to +85°C	6 SC70	AAG

Typical Operating Circuit

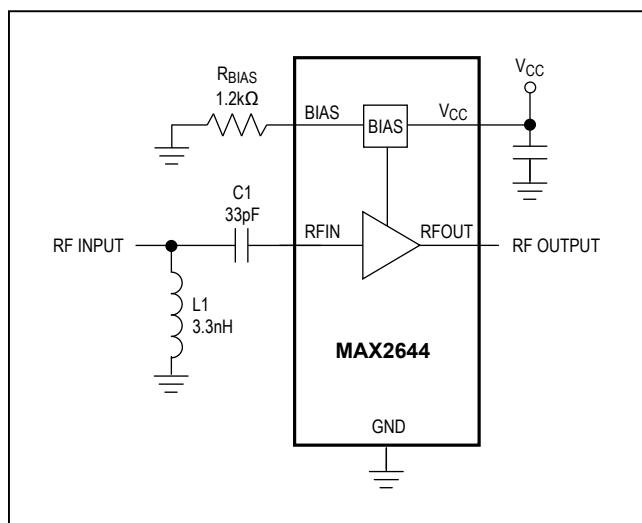

Pin Configuration

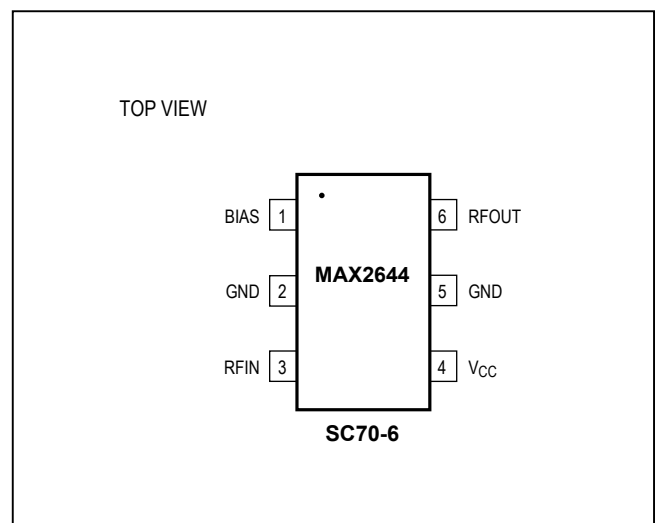

Absolute Maximum Ratings

V _{CC} to GND	-0.3V to +6V	Continuous Power Dissipation (T _A = +70°C)
RFIN, RFOUT to GND.....	±0.3V	6-Pin SC70 (derate 3.1mW/°C above +70°C).....
RFIN Power (50Ω source).....	+5dBm	Storage Temperature.....
BIAS to GND	0 to +0.3V	Lead Temperature (soldering, 10s)
Operating Temperature Range.....	-40°C to +85°C	
Maximum Junction Temperature	+150°C	

Stresses beyond those listed under "Absolute Maximum Ratings" may cause permanent damage to the device. These are stress ratings only, and functional operation of the device at these or any other conditions beyond those indicated in the operational sections of the specifications is not implied. Exposure to absolute maximum rating conditions for extended periods may affect device reliability.

DC Electrical Characteristics

(V_{CC} = +2.7V to +5.5V, R_{BIAS} = 1.2kΩ, no RF signal applied, R_{FIN} and R_{FOUT} are AC-coupled and terminated to 50Ω, T_A = -40°C to +85°C. Typical values are at V_{CC} = +3.0V, T_A = +25 °C, unless otherwise noted.) (Note 1)

PARAMETER	CONDITIONS	MIN	TYP	MAX	UNITS
Supply Voltage		2.7		5.5	V
Operating Supply Current	R _{BIAS} = 3.9kΩ		2.7		mA
	R _{BIAS} = 1.2kΩ, T _A = +25°C		7.0	9.7	
	R _{BIAS} = 1.2kΩ, T _A = -40°C to +85°C			11.0	
	R _{BIAS} = 750Ω		10.2		
Standby Supply Current	R _{BIAS} is unconnected, T _A = +25°C, V _{CC} = 3.3V			100	μA

AC ELECTRICAL CHARACTERISTICS

(MAX2644 EV kit, V_{CC} = +3.0V, f_{RFIN} = 2450MHz, P_{RFIN} = -30dBm, input and output are terminated to 50Ω, R_{BIAS} = 1.2kΩ, T_A = +25°C, unless otherwise noted.) (Note 2)

PARAMETER	CONDITIONS	MIN	TYP	MAX	UNITS
Operating Frequency	(Note 3)	2400		2500	MHz
Gain (Note 4)		15	17		dB
Gain Variation Over Temperature	T _A = -40°C to +85°C		±0.7	±1.0	dB
Input Third-Order Intercept Point (Note 5)	R _{BIAS} = 750Ω		-4		dBm
	R _{BIAS} = 1.2kΩ		-3		
	R _{BIAS} = 3.9kΩ		-8		
Input 1dB Compression Point			-13		dBm
Noise Figure	(Note 6)		2.0	2.5	dB
Input Return Loss			-15		dB
Output Return Loss			-10		dB
Reverse Isolation			-30		dB

- Note 1:** Devices are production tested at T_A = +25°C. Minimum and maximum values are guaranteed by design and characterization over temperature and supply voltages.
- Note 2:** Min/Max limits are guaranteed by design and characterization.
- Note 3:** The part has been characterized at the specified frequency range. Operation outside this range is possible but not guaranteed.
- Note 4:** Excluding PC board losses (0.3dB at the input and 0.3dB at the output of the MAX2644 EV kit).
- Note 5:** Measured with two input tones (f₁ = 2445MHz, f₂ = 2455MHz) both at -30dBm per tone. Input IP3 can be improved to +1dBm with circuit shown in Figure 2.
- Note 6:** Excluding PC board losses (0.3dB typical at the input of the MAX2644 EV kit).

Typical Operating Characteristics

($P_{RFIN} = -30\text{dBm}$, $Z_S = Z_L = 50\Omega$, $V_{CC} = +3.0\text{V}$, $f_{RFIN} = 2450\text{MHz}$, $R_{BIAS} = 1.2\text{k}\Omega$, $T_A = +25^\circ\text{C}$, unless otherwise noted.)

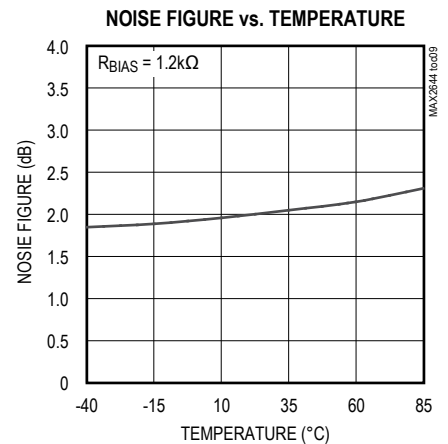
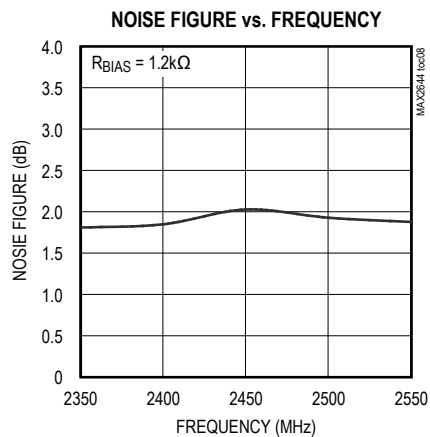
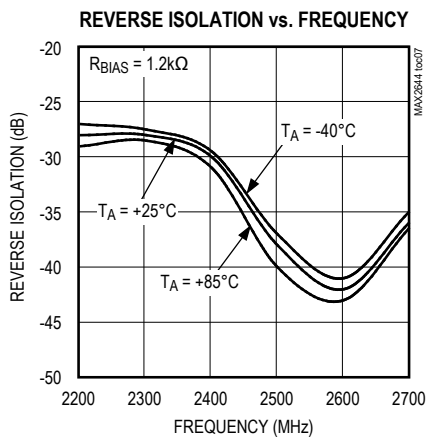
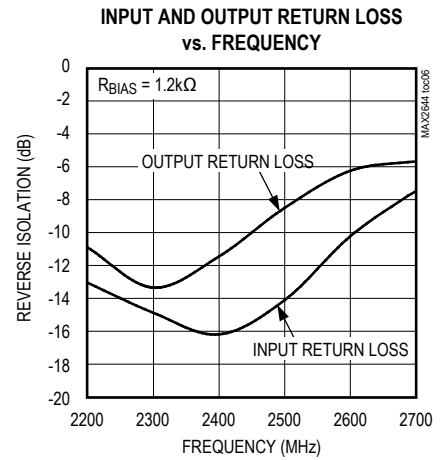
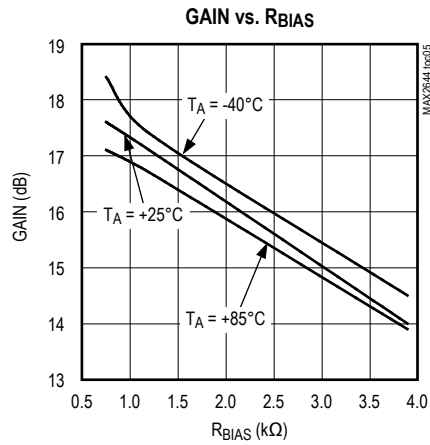
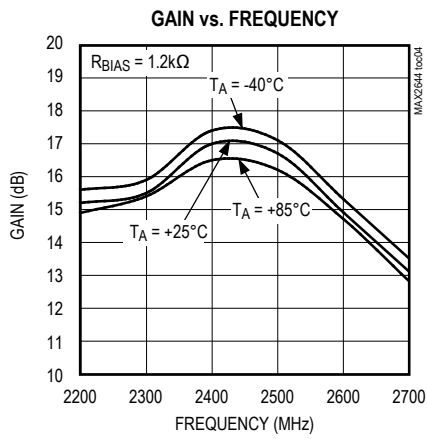
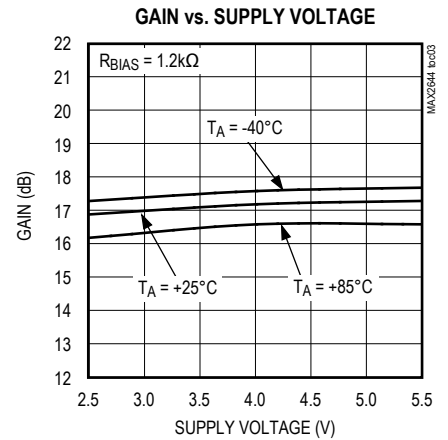
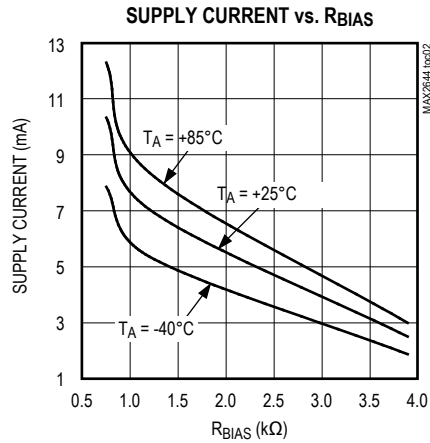
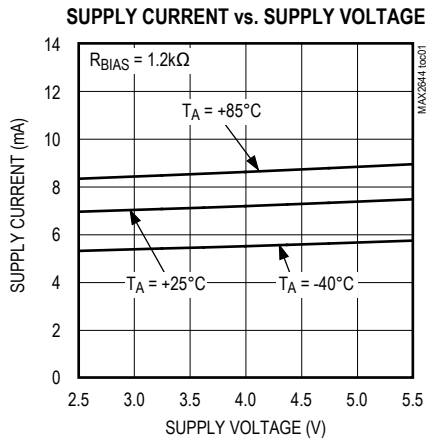

Typical Operating Characteristics (continued)

($P_{RFIN} = -30\text{dBm}$, $Z_S = Z_L = 50\Omega$, $V_{CC} = +3.0\text{V}$, $f_{RFIN} = 2450\text{MHz}$, $R_{BIAS} = 1.2\text{k}\Omega$, $T_A = +25^\circ\text{C}$, unless otherwise noted.)

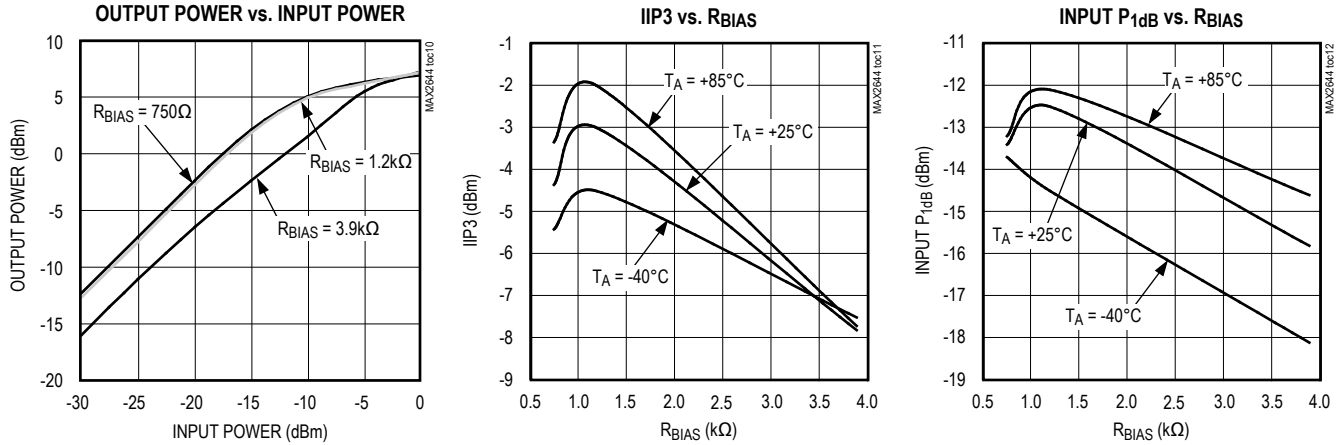

Pin Descriptions

PIN	NAME	DESCRIPTION
1	BIAS	Resistor Bias Control. Connect a resistor, R_{BIAS} , from BIAS to ground. R_{BIAS} sets IP3 and supply current. The current through this pin is approximately 60mV divided by R_{BIAS} (see <i>Applications Information</i>).
2, 5	GND	Ground. For optimum performance, provide a low-inductance connection to the ground plane.
3	RFIN	Amplifier Input. AC-couple to this pin with a DC blocking capacitor. External matching network is required for optimum performance.
4	V_{CC}	Supply Voltage. Bypass with a capacitor directly to ground at the supply pin. Refer to <i>V_{CC} Line Bypassing</i> section for more information.
6	RFOUT	Amplifier Output. AC-coupled internally.

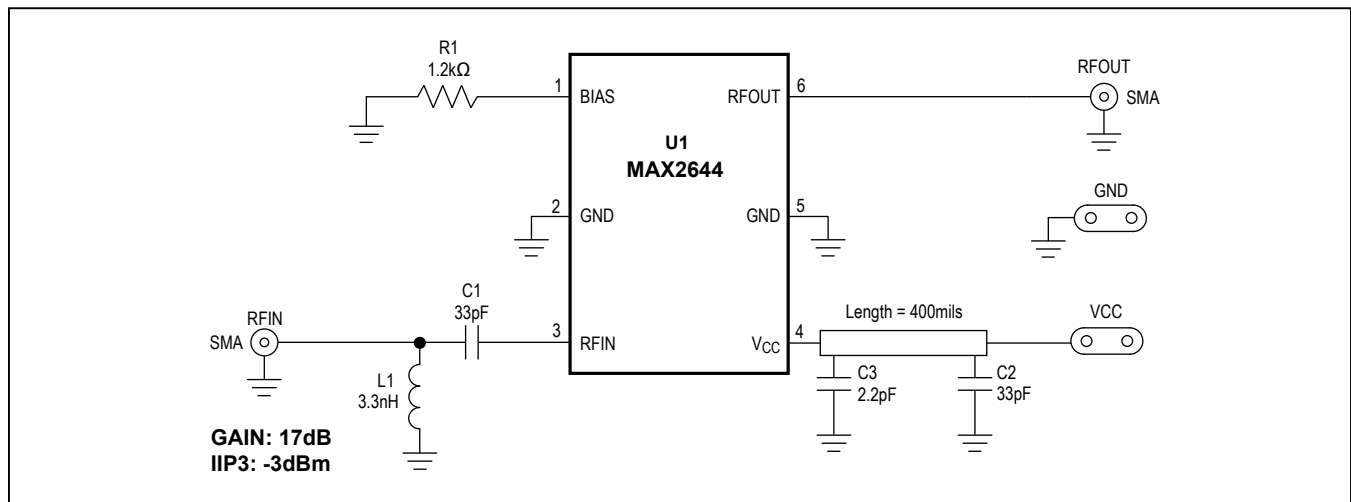

Figure 1. High Gain Design

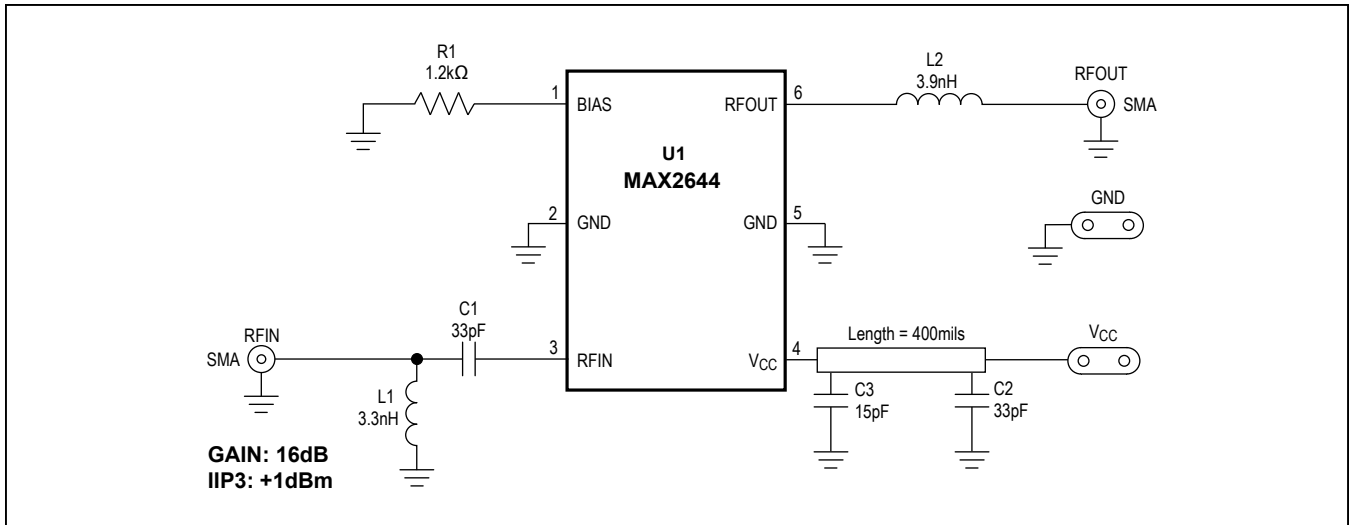

Figure 2. High Linearity Design

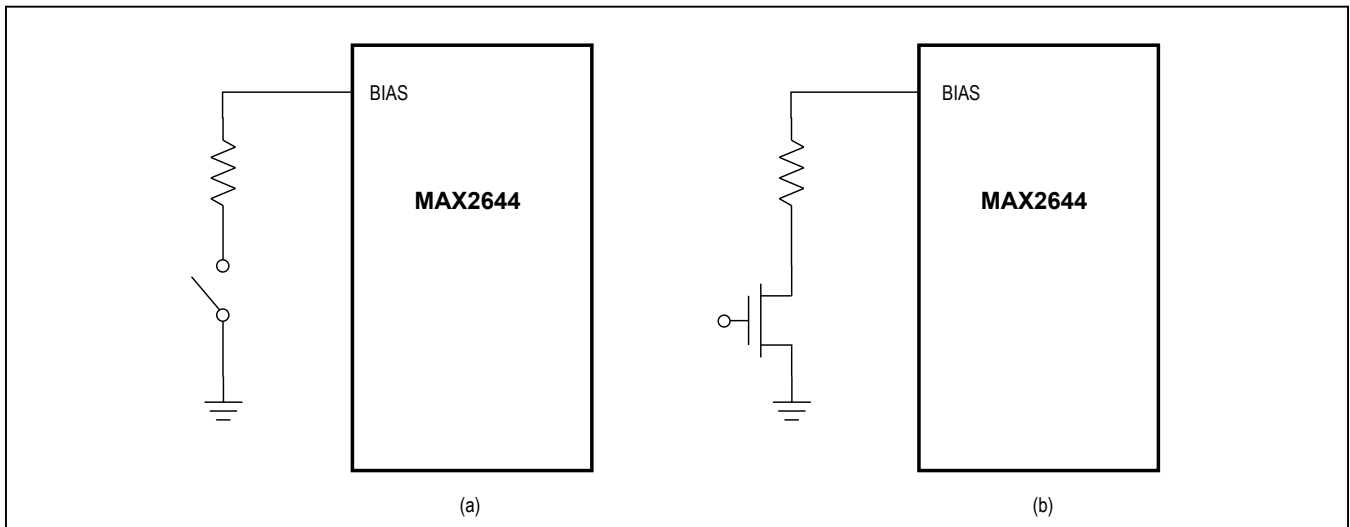

Figure 3. Recommended MAX2644 Standby Configurations

Applications Information

Input Matching

Input matching is required for optimum performance. The MAX2644 requires a simple LC matching network, as shown in the [Typical Operating Circuit](#). To further reduce cost and external component count, replace the external inductor with a microstrip transmission line. The [Typical Operating Circuit](#) shows the recommended input matching network for the MAX2644 at 2450MHz. These values are optimized for best simultaneous gain, noise figure, and return loss performance.

VCC Line Bypassing

Bypassing the VCC line is necessary for optimum gain/linearity performance. A transmission line and two capacitors are required, as shown in the schematics in Figures 1 and 2. The optimum dimensions and positions of the components are as follows: the output transmission line dimension is 0.532in (length) x 0.012in (width); the distance from C2 to the IC is 0.352in; and the distance from C3 to the IC is 0.041in. Please refer to Figures 1 and 2 for component values.

Table 1. MAX2644 Typical Scattering Parameters
($R_{BIAS} = 750\Omega$, $V_{CC} = +3.0V$, $T_A = +25^\circ C$.)

FREQ. (MHz)	S11 MAG	S11 PHASE (°)	S21 MAG	S21 PHASE (°)	S12 MAG	S12 PHASE (°)	S22 MAG	S22 PHASE (°)
2200	0.3372	-79.36	5.1940	170.97	0.0414	157.19	0.2818	-73.71
2250	0.3098	-70.09	5.3156	166.79	0.0445	146.70	0.2204	-67.13
2300	0.3283	-57.20	5.4281	159.22	0.0469	130.62	0.1566	-50.26
2350	0.4005	-50.46	5.4175	150.70	0.0441	108.72	0.1480	-3.96
2400	0.4839	-50.28	5.3346	143.93	0.0349	85.67	0.2795	15.12
2450	0.5443	-56.33	5.0687	136.45	0.0233	58.80	0.4179	11.12
2500	0.5758	-60.09	4.9556	132.16	0.0113	27.74	0.5135	3.28
2550	0.5784	-63.61	4.5952	127.68	0.0041	-38.98	0.5622	-2.66
2600	0.5698	-66.56	4.2364	126.58	0.0063	-110.49	0.5986	-7.45
2650	0.5600	-68.51	4.1376	126.51	0.0103	-128.93	0.6208	-10.43
2700	0.5533	-69.86	4.0729	120.60	0.0133	-140.21	0.6425	-12.93

Table 2. MAX2644 Typical Scattering Parameters
($R_{BIAS} = 1.2k\Omega$, $V_{CC} = +3.0V$, $T_A = +25^\circ C$.)

FREQ. (MHz)	S11 MAG	S11 PHASE (°)	S21 MAG	S21 PHASE (°)	S12 MAG	S12 PHASE (°)	S22 MAG	S22 PHASE (°)
2200	0.3482	-67.06	5.2390	-177.33	0.0402	161.53	0.2873	-76.58
2250	0.3121	-58.60	5.3790	178.72	0.0435	151.97	0.2305	-69.42
2300	0.3051	-43.64	5.5982	173.43	0.0452	136.90	0.1735	-54.22
2350	0.3693	-30.34	5.8137	166.48	0.0427	116.57	0.1582	-16.42
2400	0.4769	-29.48	5.8063	158.29	0.0341	95.13	0.2687	6.52
2450	0.5619	-35.54	5.6624	150.06	0.0236	68.36	0.4043	5.00
2500	0.5948	-42.64	5.3015	142.37	0.0117	41.34	0.5030	-2.19
2550	0.5939	-47.58	4.7813	136.67	0.0034	-13.74	0.5602	-8.04
2600	0.5825	-50.94	4.3271	134.58	0.0056	-104.09	0.5952	-12.76
2650	0.5708	-53.14	4.1961	133.48	0.0096	-124.80	0.6215	-15.97
2700	0.5604	-54.35	4.1068	128.01	0.0125	-134.75	0.6434	-18.83

Standby

Standby mode is achieved by disconnecting BIAS as shown in Figure 1. Avoid capacitance at the BIAS pin by connecting the bias resistor from BIAS to the switch.

Layout Issues

A properly designed PC board is essential to any RF/microwave circuit. Use controlled impedance lines on all high-frequency inputs and outputs. Bypass with decoupling capacitors located close to the device V_{CC} pin. For

long V_{CC} lines, it may be necessary to add additional decoupling capacitors. These additional capacitors can be located farther away from the device package. Proper grounding of the GND pins is essential. If the PC board uses a topside RF ground, connect it directly to all GND pins. For a board where the ground plane is not on the component layer, the best technique is to connect the GND pins to the board with a plated through-hole located close to the package.

Table 3. MAX2644 Typical Scattering Parameters
($R_{BIAS} = 3.9k\Omega$, $V_{CC} = +3.0V$, $T_A = +25^\circ C$.)

FREQ. (MHz)	S11 MAG	S11 PHASE (°)	S21 MAG	S21 PHASE (°)	S12 MAG	S12 PHASE (°)	S22 MAG	S22 PHASE (°)
2200	0.4894	-75.32	3.7368	-173.73	0.0348	156.35	0.2729	-62.97
2250	0.4566	-72.73	3.7718	-177.51	0.0363	147.30	0.2459	-53.68
2300	0.4335	-68.17	3.8855	177.43	0.0369	132.32	0.2211	-41.12
2350	0.4343	-61.46	3.9783	171.34	0.0344	116.21	0.2177	-21.15
2400	0.4695	-57.00	4.0230	165.15	0.0272	95.31	0.2823	-2.41
2450	0.5156	-57.52	4.0087	157.68	0.0179	70.07	0.3924	1.25
2500	0.5403	-61.04	3.8380	149.58	0.0079	42.40	0.4849	-2.71
2550	0.5423	-63.93	3.5140	143.30	0.0018	-46.47	0.5476	-7.30
2600	0.5361	-66.30	3.2048	140.25	0.0055	-112.91	0.5881	-11.35
2650	0.5280	-68.08	3.1204	138.55	0.0100	-132.25	0.6170	-14.57
2700	0.5217	-69.29	3.0860	132.16	0.0121	-133.97	0.6418	-17.44

Table 4. MAX2644 Typical Noise Parameters at $V_{CC} = +3.0V$, $T_A = +25^\circ C$, $R_{BIAS} = 750\Omega$

FREQUENCY (MHz)	F_{MIN} (dB)	$ \Gamma_{opt} $	Γ_{opt} ANGLE	R_N (Ω)
2400	1.725	0.361	66.13	24.38
2450	1.747	0.360	66.93	24.76
2500	1.769	0.358	67.72	25.14

Table 5. MAX2644 Typical Noise Parameters at $V_{CC} = +3.0V$, $T_A = +25^\circ C$, $R_{BIAS} = 1.2k\Omega$

FREQUENCY (MHz)	F_{MIN} (dB)	$ \Gamma_{opt} $	Γ_{opt} ANGLE	R_N (Ω)
2400	1.570	0.409	69.84	21.77
2450	1.589	0.408	70.63	21.94
2500	1.609	0.406	71.63	22.42

Table 6. MAX2644 Typical Noise Parameters at $V_{CC} = +3.0V$, $T_A = +25^\circ C$, $R_{BIAS} = 3.9k\Omega$

FREQUENCY (MHz)	F_{MIN} (dB)	$ \Gamma_{opt} $	Γ_{opt} ANGLE	R_N (Ω)
2400	1.497	0.510	86.55	20.58
2450	1.517	0.507	86.50	20.90
2500	1.538	0.504	88.18	21.25

Chip Information

TRANSISTOR COUNT: 87

Package Information

For the latest package outline information and land patterns (footprints), go to www.maximintegrated.com/packages. Note that a "+", "#", or "-" in the package code indicates RoHS status only. Package drawings may show a different suffix character, but the drawing pertains to the package regardless of RoHS status.

COMMON DIMENSIONS			
SYMBOL	MIN	NOM	MAX
A	0.80	0.95	1.10
A1	0.00	0.07	0.10
A2	0.80	0.90	1.00
b	0.15	0.22	0.30
c	0.10	0.14	0.18
D	1.85	2.00	2.15
e	0.65 BSC.		
E	1.15	1.25	1.35
HE	2.00	2.20	2.35
L	0.26	0.34	0.46
L1	0.425 TYP.		
Q1	0.10	0.25	0.40
PKG. CODES	X6SN-1		

NOTES:

1. ALL DIMENSIONS ARE IN MILLIMETERS.
2. DIMENSIONS ARE INCLUSIVE OF PLATING.
3. DIMENSIONS ARE EXCLUSIVE OF MOLD FLASH & METAL BURR.
4. COPLANARITY 4 MILS. MAX.
5. FOOT LENGTH MEASURED AT INTERCEPT POINT BETWEEN DATUM 'A' AND LEAD SURFACE.
6. MARKING IS FOR PACKAGE ORIENTATION REFERENCE ONLY.
7. LEAD CENTERLINES TO BE AT TRUE POSITION AS DEFINED BY BASIC DIMENSION 'e', ±0.05.
8. ALL DIMENSIONS COMPLY TO JEDEC MO-203.
9. ALL DIMENSIONS APPLY TO BOTH LEADED (-) AND LEAD FREE (+) PACKAGE CODES.

-DRAWING NOT TO SCALE-

TITLE: PACKAGE OUTLINE, 6L SC70			
APPROVAL	DOCUMENT CONTROL NO. 21-0077	REV. H	1/1

Revision History

REVISION NUMBER	REVISION DATE	DESCRIPTION	PAGES CHANGED
2	2/17	Added MAX2644EXT+, MAX2644EXT-T, and MAX2644EXT-T to <i>Ordering Information</i> table	1

For pricing, delivery, and ordering information, please contact Maxim Direct at 1-888-629-4642, or visit Maxim Integrated's website at www.maximintegrated.com.

Maxim Integrated cannot assume responsibility for use of any circuitry other than circuitry entirely embodied in a Maxim Integrated product. No circuit patent licenses are implied. Maxim Integrated reserves the right to change the circuitry and specifications without notice at any time. The parametric values (min and max limits) shown in the Electrical Characteristics table are guaranteed. Other parametric values quoted in this data sheet are provided for guidance.

Компания «Океан Электроники» предлагает заключение долгосрочных отношений при поставках импортных электронных компонентов на взаимовыгодных условиях!

Наши преимущества:

- Поставка оригинальных импортных электронных компонентов напрямую с производств Америки, Европы и Азии, а так же с крупнейших складов мира;
- Широкая линейка поставок активных и пассивных импортных электронных компонентов (более 30 млн. наименований);
- Поставка сложных, дефицитных, либо снятых с производства позиций;
- Оперативные сроки поставки под заказ (от 5 рабочих дней);
- Экспресс доставка в любую точку России;
- Помощь Конструкторского Отдела и консультации квалифицированных инженеров;
- Техническая поддержка проекта, помощь в подборе аналогов, поставка прототипов;
- Поставка электронных компонентов под контролем ВП;
- Система менеджмента качества сертифицирована по Международному стандарту ISO 9001;
- При необходимости вся продукция военного и аэрокосмического назначения проходит испытания и сертификацию в лаборатории (по согласованию с заказчиком);
- Поставка специализированных компонентов военного и аэрокосмического уровня качества (Xilinx, Altera, Analog Devices, Intersil, Interpoint, Microsemi, Actel, Aeroflex, Peregrine, VPT, Syfer, Eurofarad, Texas Instruments, MS Kennedy, Miteq, Cobham, E2V, MA-COM, Hittite, Mini-Circuits, General Dynamics и др.);

Компания «Океан Электроники» является официальным дистрибьютором и эксклюзивным представителем в России одного из крупнейших производителей разъемов военного и аэрокосмического назначения «JONHON», а так же официальным дистрибьютором и эксклюзивным представителем в России производителя высокотехнологичных и надежных решений для передачи СВЧ сигналов «FORSTAR».



JONHON

«JONHON» (основан в 1970 г.)

Разъемы специального, военного и аэрокосмического назначения:

(Применяются в военной, авиационной, аэрокосмической, морской, железнодорожной, горно- и нефтедобывающей отраслях промышленности)

«FORSTAR» (основан в 1998 г.)

ВЧ соединители, коаксиальные кабели, кабельные сборки и микроволновые компоненты:

(Применяются в телекоммуникациях гражданского и специального назначения, в средствах связи, РЛС, а так же военной, авиационной и аэрокосмической отраслях промышленности).



Телефон: 8 (812) 309-75-97 (многоканальный)

Факс: 8 (812) 320-03-32

Электронная почта: ocean@oceanchips.ru

Web: <http://oceanchips.ru/>

Адрес: 198099, г. Санкт-Петербург, ул. Калинина, д. 2, корп. 4, лит. А