

CRIMP RING ADAPTOR



Many cable terminations where heat shrink boots are used will require provision for terminating the screens too. It is achieved in this type of back shell through a ring, which can be crimped to the back shell body holding the screens in between.

For Connector Group		Page No.
J	→	VI-1 - VI-2
K	→	VI-3 - VI-4
L	→	VI-5 - VI-6
M	→	VI-7 - VI-8
N	→	VI-9 - VI-10

Note: For Connector group Identification refer Table 1 - A, B, C, D (Page 7-11) and for Material / Plating Finish, Refer Table-2 (Page 12)



Connector Group - J

Straight, 90°, 45°

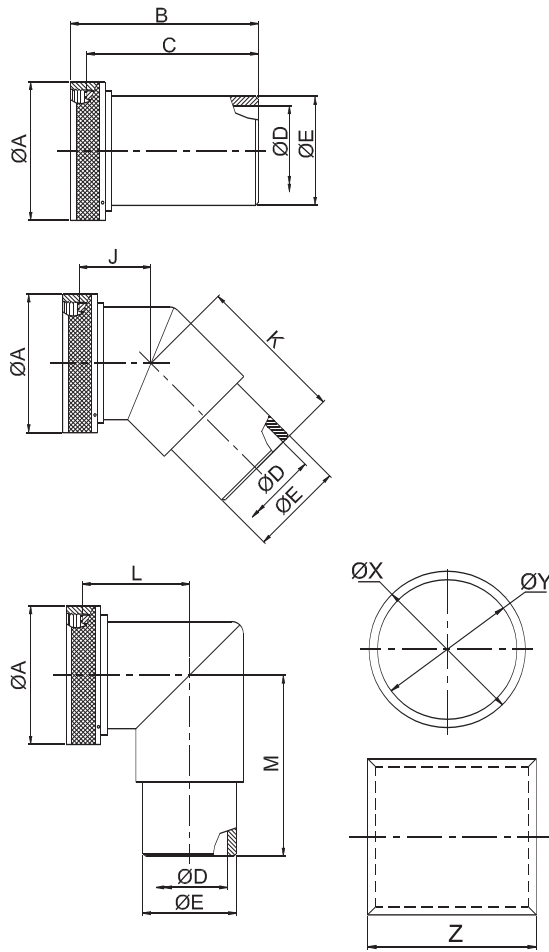

Amphenol Part Number

BC1 X X J 99 99 9 X X

Series
 BC1: Adaptor with ring
 BC2: Adaptor
 BC3: Ring

Angle
 S: straight
 A: 90deg
 B: 45deg
 X: For BC3

Coupling
 R: spin
 S: Self lock
 X: For BC3

Finish: see Table-2
 (for BC1&BC2)
 X :For BC3
 Constant: X
 Length
 9 - for standard
 Length in table / figure
 Entry Size
 99 - for standard
 Entry Size in table / figure
 Shell size
 See Table-A
 (for BC1&BC2)
 Table-B (for BC3)
 Connector group
 X: For BC3

MIL Part Number

M85049 / 99-9 -9 X

MIL Series
 Slash sheet
 26: Straight, spin couplig

Finish:
 See Table-2
 Omit for '26-2'
 Dash Number:
 See Table-A
 (for 26-1&26-3)
 Table-B(for 26-2)
 Crimp ring
 1 : Adaptor
 2 : Crimp ring
 3 : Adaptor with
 crimp ring

NOTE: * For more cable entry and length options, contact factory

		TABLE - A															
AMPHENOL PART NUMBER DESIGNATOR	MIL PART NUMBER DESIGNATOR	CONNECTOR SHELL SIZE	A DIA. (MAX)		B (MAX)		C (MAX)		D DIA. (MAX)		E DIA. (MAX)		J (MAX)		K (MAX)		
			INCH	MM	INCH	MM	INCH	MM	INCH	MM	INCH	MM	INCH	MM	INCH	MM	
08	08	8	0.62	15.67	1.28	32.44	0.96	24.38	0.25	6.35	0.35	8.81	0.64	16.23	0.70	17.83	
10	10	10	0.73	18.64	1.28	32.44	0.96	24.38	0.33	8.26	0.50	12.70	0.66	16.87	0.73	18.59	
12	12	7/12	0.86	21.79	1.28	32.44	0.96	24.38	0.42	10.67	0.51	12.95	0.69	17.48	1.04	26.42	
14	14	12/14	0.98	24.99	1.28	32.44	0.96	24.38	0.54	13.72	0.63	16.00	0.71	17.91	1.07	27.18	
16	16	19/16	1.11	28.24	1.28	32.44	0.96	24.38	0.67	17.02	0.76	19.30	0.73	18.59	1.09	27.69	
18	18	27/18	1.22	30.94	1.28	32.44	0.96	24.38	0.79	20.04	0.89	22.61	0.75	19.00	1.10	27.94	
20	20	37/20	1.35	34.16	1.28	32.44	0.96	24.38	0.91	23.22	1.01	25.65	0.77	19.63	1.12	28.45	
22	22	22	1.47	37.29	1.28	32.44	0.96	24.38	1.04	26.39	1.13	28.70	0.80	20.32	1.16	29.46	
24	24	24	1.59	40.46	1.28	32.44	0.96	24.38	1.11	28.24	1.20	30.48	0.82	20.90	1.19	30.23	
28	28	28	1.97	50.01	1.44	36.55	0.96	24.38	1.39	35.28	1.56	39.62	-----	-----	-----	-----	
32	32	32	2.22	56.36	1.44	36.55	0.96	24.38	1.64	41.53	1.81	45.97	-----	-----	-----	-----	
36	36	36	2.47	62.71	1.44	36.55	0.96	24.38	1.85	46.99	2.06	52.32	-----	-----	-----	-----	
40	40	40	2.72	69.06	1.44	36.55	0.96	24.38	2.07	52.45	2.31	58.67	-----	-----	-----	-----	
44	44	44	2.97	75.41	1.44	36.55	0.96	24.38	2.32	58.93	2.56	65.02	-----	-----	-----	-----	
48	48	48	3.22	81.76	1.44	36.55	0.96	24.38	2.57	65.28	2.81	71.37	-----	-----	-----	-----	

Table Continued

AMPHENOL PART NUMBER DESIGNATOR	MIL PART NUMBER DESIGNATOR	CONNECTOR SHELL SIZE SIZE	L (MAX)		M (MAX)	
			INCH	MM	INCH	MM
SHELL SIZE	DASH NO.					
08	08	8	0.75	19.05	0.81	20.62
10	10	10	0.81	20.62	0.88	22.23
12	12	7/12	0.88	22.23	1.22	30.99
14	14	12/14	0.92	23.37	1.29	32.77
16	16	19/16	0.98	24.89	1.35	34.29
18	18	27/18	1.02	25.91	1.37	34.80
20	20	37/20	1.08	27.43	1.43	36.32
22	22	22	1.14	28.96	1.51	38.35
24	24	24	1.20	30.48	1.58	40.13
28	28	28	-----	-----	-----	-----
32	32	32	-----	-----	-----	-----
36	36	36	-----	-----	-----	-----
40	40	40	-----	-----	-----	-----
44	44	44	-----	-----	-----	-----
48	48	48	-----	-----	-----	-----

AMPHENOL PART NUMBER DESIGNATOR	MIL PART NUMBER DESIGNATOR		CONNECTOR SHELL SIZE SIZE	X DIA.				Y DIA.				Z	
				MIN		MAX		MIN		MAX		INCH	MM
				INCH	MM	INCH	MM	INCH	MM	INCH	MM		
SHELL SIZE	DASH NO.	PART NO COLOR											
08	08	GREEN	8	0.45	11.38	0.46	11.63	0.40	10.16	0.41	10.41	0.25	6.35
10	10	RED	10	0.66	16.76	0.68	17.27	0.59	14.86	0.60	15.11	0.44	11.18
12	12	RED	7/12	0.66	16.76	0.68	17.27	0.59	14.86	0.60	15.11	0.44	11.18
14	14	BLUE	12/14	0.78	19.81	0.80	20.32	0.71	17.91	0.72	18.16	0.44	11.18
16	16	GRAY	19/16	0.91	23.11	0.93	23.62	0.84	21.21	0.85	21.46	0.44	11.18
18	18	BROWN	27/18	1.08	27.43	1.10	27.94	1.01	25.53	1.02	25.78	0.44	11.18
20	20	GREEN	37/20	1.20	30.48	1.22	30.99	1.13	28.58	1.14	28.83	0.44	11.18
22	22	PINK	22	1.32	33.53	1.34	34.04	1.25	31.62	1.26	31.88	0.44	11.18
24	24	YELLOW	24	1.39	35.23	1.41	35.74	1.31	33.32	1.32	33.58	0.44	11.18
28	28	RED	28	1.74	44.20	1.76	44.70	1.67	42.29	1.68	42.55	0.44	11.18
32	32	GRAY	32	1.99	50.55	2.01	51.05	1.92	48.64	1.93	48.90	0.44	11.18
36	36	GREEN	36	2.24	56.90	2.26	57.40	2.17	54.99	2.18	55.25	0.44	11.18
40	40	ORANGE	40	2.49	63.25	2.51	63.75	2.42	61.34	2.43	61.60	0.44	11.18
44	44	YELLOW	44	2.74	69.60	2.76	70.10	2.67	67.69	2.68	67.95	0.44	11.18
48	48	BLUE	48	2.99	75.95	3.01	76.45	2.92	74.04	2.93	74.30	0.44	11.18

Note:The material&finish for the crimp ring will always be as follows

Material:Copper as per ASTM B-75

Finish:Tin plating as per MIL-T-10727,Type-1

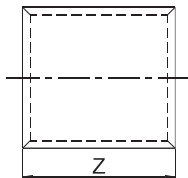
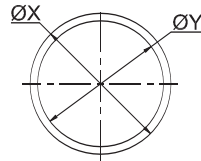
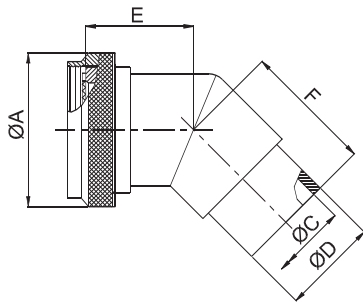
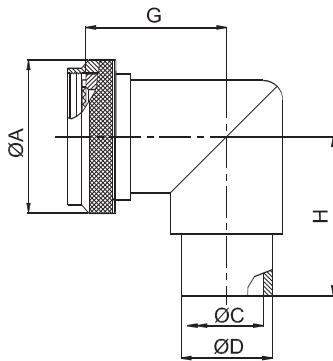
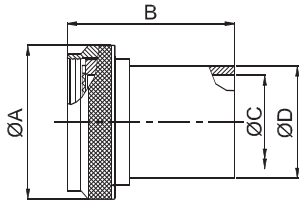

Amphenol Part Number

BC1 X X K 99 99 9 X X

Series
BC1: Adaptor with ring
BC2: Adaptor
BC3: Ring

Angle
S: straight
A: 90deg
B: 45deg
X: For BC3

Coupling
R: spin
S: Self lock
X: For BC3

Finish: see Table-2
(for BC1&BC2)
X: For BC3

Constant: X

Length
9 - for standard
Length in table / figure

Entry Size
99 - for standard
Entry Size in table / figure

Shell size
See Table-A
(for BC1&BC2)
Table-B (for BC3)

Connector group
X: For BC3

MIL Part Number

M85049 / 99-9 -9 X

MIL Series

Slash sheet
33: Straight, spin couplig

Finish:
See Table-2

Dash Number:
See Table-A

Crimp ring
2 :Adaptor without
crimp ring

NOTE: * For more cable entry and length options, contact factory

TABLE - A												
AMPHENOL PART NUMBER DESIGNATOR	MIL PART NUMBER DESIGNATOR	CONNECTOR SHELL SIZE SE - II / I	A DIA. (MAX)		B (MAX)		C DIA. (MAX)		D DIA. (MAX)		E (MAX)	
			INCH	MM	INCH	MM	INCH	MM	INCH	MM	INCH	MM
08	08	8 / 9	0.75	19.05	1.14	28.96	0.27	6.86	0.35	8.89	0.64	16.23
10	10	10 / 11	0.85	21.59	1.14	28.96	0.34	8.64	0.50	12.70	0.66	16.87
12	12	12 / 13	1.00	25.40	1.14	28.96	0.44	11.18	0.51	12.95	0.69	17.48
14	14	14 / 15	1.10	27.94	1.14	28.96	0.56	14.22	0.63	16.00	0.71	17.91
16	16	16 / 17	1.25	31.75	1.14	28.96	0.69	17.53	0.76	19.30	0.73	18.59
18	18	18 / 19	1.40	35.56	1.14	28.96	0.80	20.32	0.89	22.61	0.75	19.00
20	20	20 / 21	1.50	38.10	1.14	28.96	0.93	23.62	1.01	25.65	0.77	19.63
22	22	22 / 23	1.65	41.91	1.14	28.96	1.05	26.67	1.13	28.70	0.80	20.32
24	24	24 / 25	1.75	44.45	1.14	28.96	1.13	28.70	1.20	30.48	0.82	20.90

Table Continued

AMPHENOL PART NUMBER DESIGNATOR	MIL PART NUMBER DESIGNATOR	CONNECTOR SHELL SIZE SE - II / I	F (MAX)		G (MAX)		H (MAX)	
			INCH	MM	INCH	MM	INCH	MM
08	08	8 / 9	0.70	17.83	0.75	19.05	0.81	20.62
10	10	10 / 11	0.73	18.59	0.81	20.62	0.88	22.23
12	12	12 / 13	1.04	26.42	0.88	22.23	1.22	30.99
14	14	14 / 15	1.07	27.18	0.92	23.37	1.29	32.77
16	16	16 / 17	1.09	27.69	0.98	24.89	1.35	34.29
18	18	18 / 19	1.10	27.94	1.02	25.91	1.37	34.80
20	20	20 / 21	1.12	28.45	1.08	27.43	1.43	36.32
22	22	22 / 23	1.16	29.46	1.14	28.96	1.51	38.35
24	24	24 / 25	1.19	30.23	1.20	30.48	1.58	40.13

AMPHENOL PART NUMBER DESIGNATOR	MIL PART NUMBER DESIGNATOR		CONNECTOR SHELL SIZE SIZE	X DIA.				Y DIA.				Z	
				MIN		MAX		MIN		MAX		INCH	MM
				INCH	MM	INCH	MM	INCH	MM	INCH	MM		
08	08	GREEN	8	0.45	11.38	0.46	11.63	0.40	10.16	0.41	10.41	0.25	6.35
10	10	RED	10	0.66	16.76	0.68	17.27	0.59	14.86	0.60	15.11	0.44	11.18
12	12	RED	7/12	0.66	16.76	0.68	17.27	0.59	14.86	0.60	15.11	0.44	11.18
14	14	BLUE	12/14	0.78	19.81	0.80	20.32	0.71	17.91	0.72	18.16	0.44	11.18
16	16	GRAY	19/16	0.91	23.11	0.93	23.62	0.84	21.21	0.85	21.46	0.44	11.18
18	18	BROWN	27/18	1.08	27.43	1.10	27.94	1.01	25.53	1.02	25.78	0.44	11.18
20	20	GREEN	37/20	1.20	30.48	1.22	30.99	1.13	28.58	1.14	28.83	0.44	11.18
22	22	PINK	22	1.32	33.53	1.34	34.04	1.25	31.62	1.26	31.88	0.44	11.18
24	24	YELLOW	24	1.39	35.23	1.41	35.74	1.31	33.32	1.32	33.58	0.44	11.18
28	28	RED	28	1.74	44.20	1.76	44.70	1.67	42.29	1.68	42.55	0.44	11.18
32	32	GRAY	32	1.99	50.55	2.01	51.05	1.92	48.64	1.93	48.90	0.44	11.18
36	36	GREEN	36	2.24	56.90	2.26	57.40	2.17	54.99	2.18	55.25	0.44	11.18
40	40	ORANGE	40	2.49	63.25	2.51	63.75	2.42	61.34	2.43	61.60	0.44	11.18
44	44	YELLOW	44	2.74	69.60	2.76	70.10	2.67	67.69	2.68	67.95	0.44	11.18
48	48	BLUE	48	2.99	75.95	3.01	76.45	2.92	74.04	2.93	74.30	0.44	11.18

Note: The material & finish for the crimp ring will always be as follows

Material: Copper as per ASTM B-75

Finish: Tin plating as per MIL-T-10727, Type-1

Connector Group - L

Straight, 90°, 45°

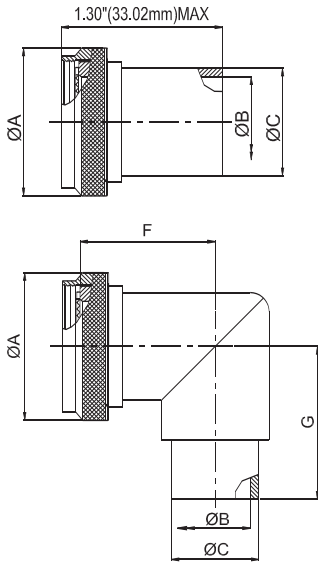

Amphenol Part Number

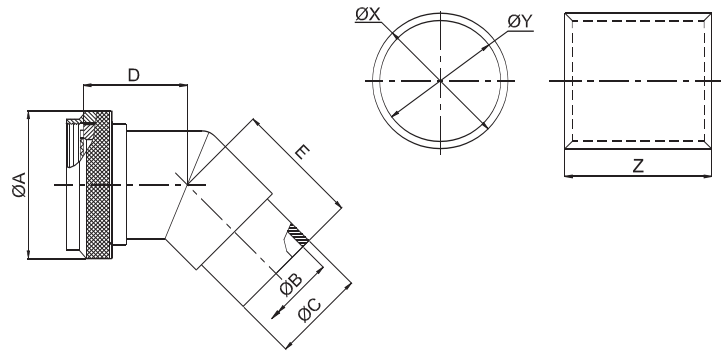
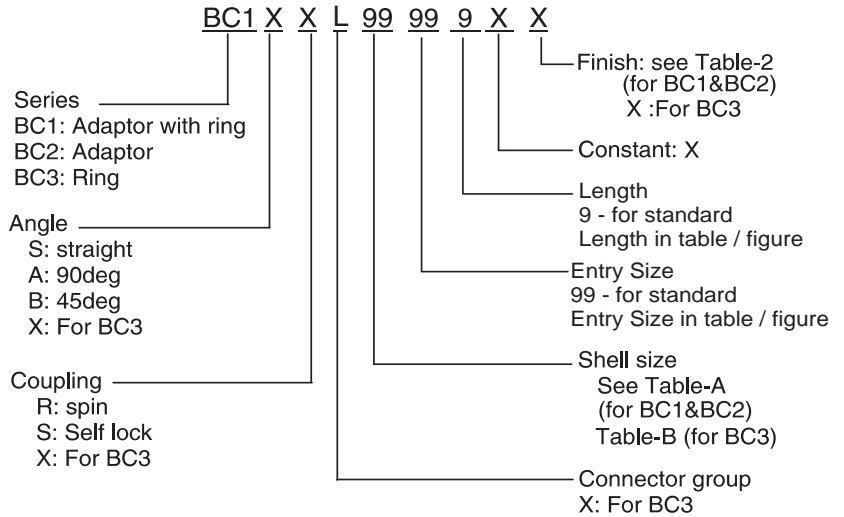

MIL Part Number

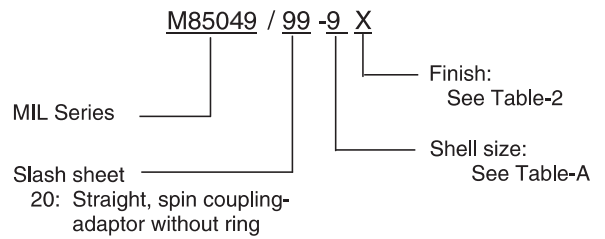

NOTE: * For more cable entry and length options, contact factory

TABLE - A

AMPHENOL PART NUMBER DESIGNATOR	MIL PART NUMBER DESIGNATOR	CONNECTOR SHELL SIZE/CODE (REF.)	A DIA. (MAX)		B DIA. (MIN)		C DIA. (MAX)		D (MAX)		E (MAX)		F (MAX)		G (MAX)	
			INCH	MM	INCH	MM	INCH	MM	INCH	MM	INCH	MM	INCH	MM	INCH	MM
08	09	09 / A	0.75	19.05	0.27	6.73	0.35	8.81	0.64	16.23	0.70	17.83	0.75	19.05	0.81	20.62
10	11	11 / B	0.85	21.59	0.34	8.71	0.50	12.65	0.66	16.87	0.73	18.59	0.81	20.62	0.88	22.23
12	13	13 / C	1.00	25.40	0.44	11.10	0.51	12.95	0.69	17.48	1.04	26.42	0.88	22.23	1.22	30.99
14	15	15 / D	1.10	27.94	0.56	14.27	0.63	16.00	0.71	17.91	1.07	27.18	0.92	23.37	1.29	32.77
16	17	17 / E	1.25	31.75	0.69	17.45	0.76	19.30	0.73	18.59	1.09	27.69	0.98	24.89	1.35	34.29
18	19	19 / F	1.40	35.56	0.81	20.62	0.89	22.61	0.75	19.00	1.10	27.94	1.02	25.91	1.37	34.80
20	21	21 / G	1.50	38.10	0.94	23.80	1.01	25.65	0.77	19.63	1.12	28.45	1.08	27.43	1.43	36.32
22	23	23 / H	1.65	41.91	1.05	26.57	1.13	28.70	0.80	20.32	1.16	29.46	1.14	28.96	1.51	38.35
24	25	25 / J	1.75	44.45	1.13	28.58	1.20	30.53	0.82	20.90	1.19	30.23	1.20	30.48	1.58	40.13

TABLE - B												
S.A.E. PART NUMBER DESIGNATOR		CONNECTOR SHELL SIZE	X DIA.				Y DIA.				Z	
DASH NO.	PART NO COLOR		MIN		MAX		MIN		MAX		INCH	MM
			INCH	MM	INCH	MM	INCH	MM	INCH	MM		
08	GREEN	8	0.45	11.38	0.46	11.63	0.40	10.16	0.41	10.41	0.25	6.35
10	RED	10	0.66	16.76	0.68	17.27	0.59	14.86	0.60	15.11	0.44	11.18
12	RED	7/12	0.66	16.76	0.68	17.27	0.59	14.86	0.60	15.11	0.44	11.18
14	BLUE	12/14	0.78	19.81	0.80	20.32	0.71	17.91	0.72	18.16	0.44	11.18
16	GRAY	19/16	0.91	23.11	0.93	23.62	0.84	21.21	0.85	21.46	0.44	11.18
18	BROWN	27/18	1.08	27.43	1.10	27.94	1.01	25.53	1.02	25.78	0.44	11.18
20	GREEN	37/20	1.20	30.48	1.22	30.99	1.13	28.58	1.14	28.83	0.44	11.18
22	PINK	22	1.32	33.53	1.34	34.04	1.25	31.62	1.26	31.88	0.44	11.18
24	YELLOW	24	1.39	35.23	1.41	35.74	1.31	33.32	1.32	33.58	0.44	11.18
28	RED	28	1.74	44.20	1.76	44.70	1.67	42.29	1.68	42.55	0.44	11.18
32	GRAY	32	1.99	50.55	2.01	51.05	1.92	48.64	1.93	48.90	0.44	11.18
36	GREEN	36	2.24	56.90	2.26	57.40	2.17	54.99	2.18	55.25	0.44	11.18
40	ORANGE	40	2.49	63.25	2.51	63.75	2.42	61.34	2.43	61.60	0.44	11.18
44	YELLOW	44	2.74	69.60	2.76	70.10	2.67	67.69	2.68	67.95	0.44	11.18
48	BLUE	48	2.99	75.95	3.01	76.45	2.92	74.04	2.93	74.30	0.44	11.18

Material and finish for the crimp ring will always be as follows

Material as per ASTM B-75

Finish as per MIL-T-10727, Type-1



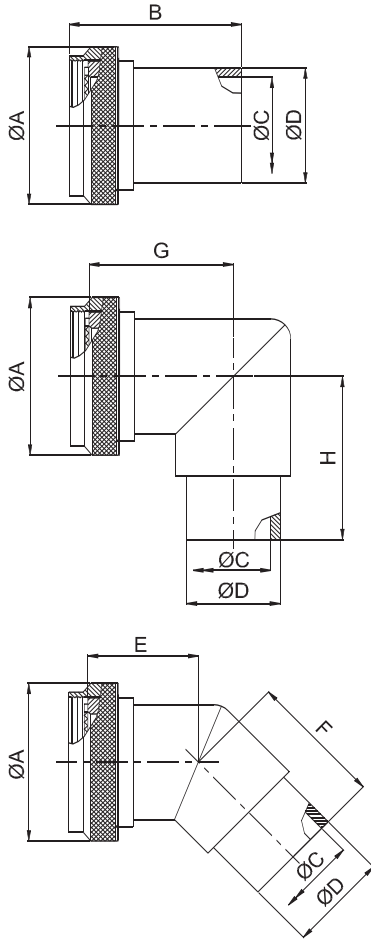

Amphenol Part Number

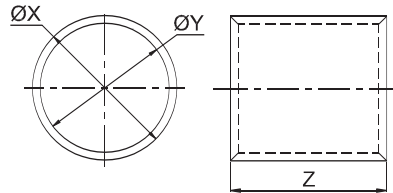
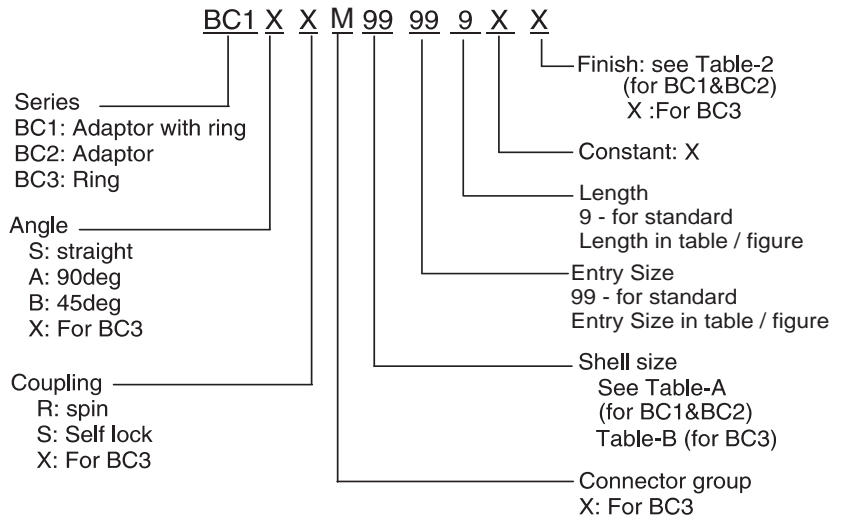

NOTE: * For more cable entry and length options, contact factory

TABLE - A

AMPHENOL PART NUMBER DESIGNATOR	CONNECTOR SHELL SIZE	A DIA. (MAX)		B (MAX)		C DIA. (MAX)		D DIA. (MAX)		E (MAX)		F (MAX)		G (MAX)		H (MAX)	
		INCH	MM	INCH	MM	INCH	MM	INCH	MM	INCH	MM	INCH	MM	INCH	MM	INCH	MM
08	8 / 9	0.75	19.05	1.14	28.96	0.27	6.86	0.35	8.89	0.64	16.23	0.70	17.83	0.75	19.05	0.81	20.62
10	10 / 11	0.85	21.59	1.14	28.96	0.34	8.64	0.50	12.70	0.66	16.87	0.73	18.59	0.81	20.62	0.88	22.23
12	12 / 13	1.00	25.40	1.14	28.96	0.44	11.18	0.51	12.95	0.69	17.48	1.04	26.42	0.88	22.23	1.22	30.99
14	14 / 15	1.10	27.94	1.14	28.96	0.56	14.22	0.63	16.00	0.71	17.91	1.07	27.18	0.92	23.37	1.29	32.77
16	16 / 17	1.25	31.75	1.14	28.96	0.69	17.53	0.76	19.30	0.73	18.59	1.09	27.69	0.98	24.89	1.35	34.29
18	18 / 19	1.40	35.56	1.14	28.96	0.80	20.32	0.89	22.61	0.75	19.00	1.10	27.94	1.02	25.91	1.37	34.80
20	20 / 21	1.50	38.10	1.14	28.96	0.93	23.62	1.01	25.65	0.77	19.63	1.12	28.45	1.08	27.43	1.43	36.32
22	22 / 23	1.65	41.91	1.14	28.96	1.05	26.67	1.13	28.70	0.80	20.32	1.16	29.46	1.14	28.96	1.51	38.35
24	24 / 25	1.75	44.45	1.14	28.96	1.13	28.70	1.20	30.48	0.82	20.90	1.19	30.23	1.20	30.48	1.58	40.13

TABLE - B												
MIL PART NUMBER DESIGNATOR		CONNECTOR SHELL SIZE	X DIA.				Y DIA.				Z	
DASH NO.	PART NO COLOR		MIN		MAX		MIN		MAX		INCH	MM
			INCH	MM	INCH	MM	INCH	MM	INCH	MM		
08	GREEN	8	0.45	11.38	0.46	11.63	0.40	10.16	0.41	10.41	0.25	6.35
10	RED	10	0.66	16.76	0.68	17.27	0.59	14.86	0.60	15.11	0.44	11.18
12	RED	7/12	0.66	16.76	0.68	17.27	0.59	14.86	0.60	15.11	0.44	11.18
14	BLUE	12/14	0.78	19.81	0.80	20.32	0.71	17.91	0.72	18.16	0.44	11.18
16	GRAY	19/16	0.91	23.11	0.93	23.62	0.84	21.21	0.85	21.46	0.44	11.18
18	BROWN	27/18	1.08	27.43	1.10	27.94	1.01	25.53	1.02	25.78	0.44	11.18
20	GREEN	37/20	1.20	30.48	1.22	30.99	1.13	28.58	1.14	28.83	0.44	11.18
22	PINK	22	1.32	33.53	1.34	34.04	1.25	31.62	1.26	31.88	0.44	11.18
24	YELLOW	24	1.39	35.23	1.41	35.74	1.31	33.32	1.32	33.58	0.44	11.18
28	RED	28	1.74	44.20	1.76	44.70	1.67	42.29	1.68	42.55	0.44	11.18
32	GRAY	32	1.99	50.55	2.01	51.05	1.92	48.64	1.93	48.90	0.44	11.18
36	GREEN	36	2.24	56.90	2.26	57.40	2.17	54.99	2.18	55.25	0.44	11.18
40	ORANGE	40	2.49	63.25	2.51	63.75	2.42	61.34	2.43	61.60	0.44	11.18
44	YELLOW	44	2.74	69.60	2.76	70.10	2.67	67.69	2.68	67.95	0.44	11.18
48	BLUE	48	2.99	75.95	3.01	76.45	2.92	74.04	2.93	74.30	0.44	11.18

Material and finish for the crimp ring will always be as follows

Material as per ASTM B-75

Finishing as per MIL-T-10727, Type-1

Connector Group - N

Straight, 90°, 45°

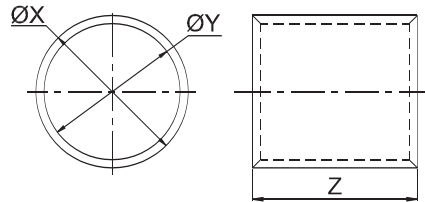
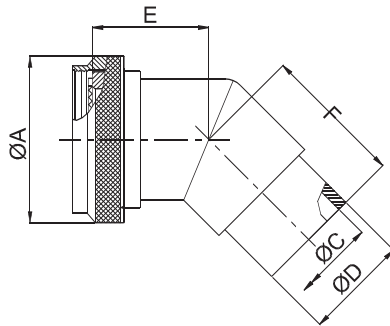
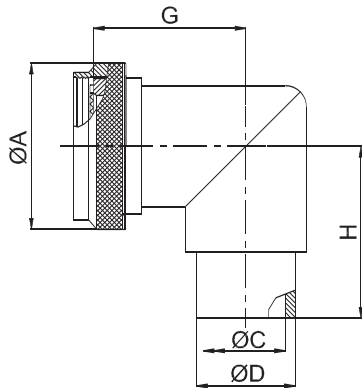
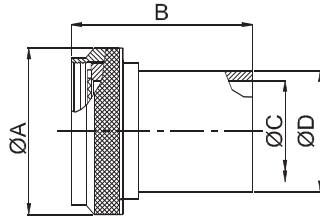

Amphenol Part Number

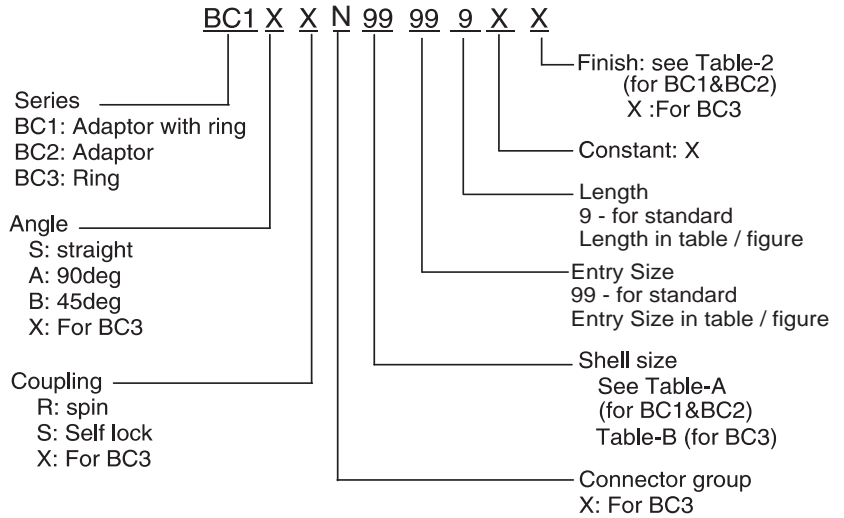

NOTE: * For more cable entry and length options, contact factory

TABLE - A																	
AMPHENOL PART NUMBER DESIGNATOR	CONNECTOR SHELL SIZE	A DIA. (MAX)		B (MAX)		C DIA. (MAX)		D DIA. (MAX)		E (MAX)		F (MAX)		G (MAX)		H (MAX)	
		INCH	MM	INCH	MM	INCH	MM	INCH	MM	INCH	MM	INCH	MM	INCH	MM	INCH	MM
08	8 / 9	0.75	19.05	1.14	28.96	0.27	6.86	0.35	8.89	0.64	16.23	0.70	17.83	0.75	19.05	0.81	20.62
10	10 / 11	0.85	21.59	1.14	28.96	0.34	8.64	0.50	12.70	0.66	16.87	0.73	18.59	0.81	20.62	0.88	22.23
12	12 / 13	1.00	25.40	1.14	28.96	0.44	11.18	0.51	12.95	0.69	17.48	1.04	26.42	0.88	22.23	1.22	30.99
14	14 / 15	1.10	27.94	1.14	28.96	0.56	14.22	0.63	16.00	0.71	17.91	1.07	27.18	0.92	23.37	1.29	32.77
16	16 / 17	1.25	31.75	1.14	28.96	0.69	17.53	0.76	19.30	0.73	18.59	1.09	27.69	0.98	24.89	1.35	34.29
18	18 / 19	1.40	35.56	1.14	28.96	0.80	20.32	0.89	22.61	0.75	19.00	1.10	27.94	1.02	25.91	1.37	34.80
20	20 / 21	1.50	38.10	1.14	28.96	0.93	23.62	1.01	25.65	0.77	19.63	1.12	28.45	1.08	27.43	1.43	36.32
22	22 / 23	1.65	41.91	1.14	28.96	1.05	26.67	1.13	28.70	0.80	20.32	1.16	29.46	1.14	28.96	1.51	38.35
24	24 / 25	1.75	44.45	1.14	28.96	1.13	28.70	1.20	30.48	0.82	20.90	1.19	30.23	1.20	30.48	1.58	40.13



TABLE - B

AMPHENOL PART NUMBER DESIGNATOR	MIL PART NUMBER DESIGNATOR		CONNECTOR SHELL SIZE SIZE	X DIA.				Y DIA.				Z	
				MIN		MAX		MIN		MAX		INCH	MM
				INCH	MM	INCH	MM	INCH	MM	INCH	MM		
08	08	GREEN	8	0.45	11.38	0.46	11.63	0.40	10.16	0.41	10.41	0.25	6.35
10	10	RED	10	0.66	16.76	0.68	17.27	0.59	14.86	0.60	15.11	0.44	11.18
12	12	RED	7/12	0.66	16.76	0.68	17.27	0.59	14.86	0.60	15.11	0.44	11.18
14	14	BLUE	12/14	0.78	19.81	0.80	20.32	0.71	17.91	0.72	18.16	0.44	11.18
16	16	GRAY	19/16	0.91	23.11	0.93	23.62	0.84	21.21	0.85	21.46	0.44	11.18
18	18	BROWN	27/18	1.08	27.43	1.10	27.94	1.01	25.53	1.02	25.78	0.44	11.18
20	20	GREEN	37/20	1.20	30.48	1.22	30.99	1.13	28.58	1.14	28.83	0.44	11.18
22	22	PINK	22	1.32	33.53	1.34	34.04	1.25	31.62	1.26	31.88	0.44	11.18
24	24	YELLOW	24	1.39	35.23	1.41	35.74	1.31	33.32	1.32	33.58	0.44	11.18
28	28	RED	28	1.74	44.20	1.76	44.70	1.67	42.29	1.68	42.55	0.44	11.18
32	32	GRAY	32	1.99	50.55	2.01	51.05	1.92	48.64	1.93	48.90	0.44	11.18
36	36	GREEN	36	2.24	56.90	2.26	57.40	2.17	54.99	2.18	55.25	0.44	11.18
40	40	ORANGE	40	2.49	63.25	2.51	63.75	2.42	61.34	2.43	61.60	0.44	11.18
44	44	YELLOW	44	2.74	69.60	2.76	70.10	2.67	67.69	2.68	67.95	0.44	11.18
48	48	BLUE	48	2.99	75.95	3.01	76.45	2.92	74.04	2.93	74.30	0.44	11.18

Note: The material & finish for the crimp ring will always be as follows

Material: Copper as per ASTM B-75

Finish: Tin plating as per MIL-T-10727, Type-1

Компания «Океан Электроники» предлагает заключение долгосрочных отношений при поставках импортных электронных компонентов на взаимовыгодных условиях!

Наши преимущества:

- Поставка оригинальных импортных электронных компонентов напрямую с производств Америки, Европы и Азии, а так же с крупнейших складов мира;
- Широкая линейка поставок активных и пассивных импортных электронных компонентов (более 30 млн. наименований);
- Поставка сложных, дефицитных, либо снятых с производства позиций;
- Оперативные сроки поставки под заказ (от 5 рабочих дней);
- Экспресс доставка в любую точку России;
- Помощь Конструкторского Отдела и консультации квалифицированных инженеров;
- Техническая поддержка проекта, помощь в подборе аналогов, поставка прототипов;
- Поставка электронных компонентов под контролем ВП;
- Система менеджмента качества сертифицирована по Международному стандарту ISO 9001;
- При необходимости вся продукция военного и аэрокосмического назначения проходит испытания и сертификацию в лаборатории (по согласованию с заказчиком);
- Поставка специализированных компонентов военного и аэрокосмического уровня качества (Xilinx, Altera, Analog Devices, Intersil, Interpoint, Microsemi, Actel, Aeroflex, Peregrine, VPT, Syfer, Eurofarad, Texas Instruments, MS Kennedy, Miteq, Cobham, E2V, MA-COM, Hittite, Mini-Circuits, General Dynamics и др.);

Компания «Океан Электроники» является официальным дистрибьютором и эксклюзивным представителем в России одного из крупнейших производителей разъемов военного и аэрокосмического назначения «JONHON», а так же официальным дистрибьютором и эксклюзивным представителем в России производителя высокотехнологичных и надежных решений для передачи СВЧ сигналов «FORSTAR».



JONHON

«JONHON» (основан в 1970 г.)

Разъемы специального, военного и аэрокосмического назначения:

(Применяются в военной, авиационной, аэрокосмической, морской, железнодорожной, горно- и нефтедобывающей отраслях промышленности)

«FORSTAR» (основан в 1998 г.)

ВЧ соединители, коаксиальные кабели, кабельные сборки и микроволновые компоненты:

(Применяются в телекоммуникациях гражданского и специального назначения, в средствах связи, РЛС, а так же военной, авиационной и аэрокосмической отраслях промышленности).



Телефон: 8 (812) 309-75-97 (многоканальный)

Факс: 8 (812) 320-03-32

Электронная почта: ocean@oceanchips.ru

Web: <http://oceanchips.ru/>

Адрес: 198099, г. Санкт-Петербург, ул. Калинина, д. 2, корп. 4, лит. А