

# SSL - Discrete Wire IDC

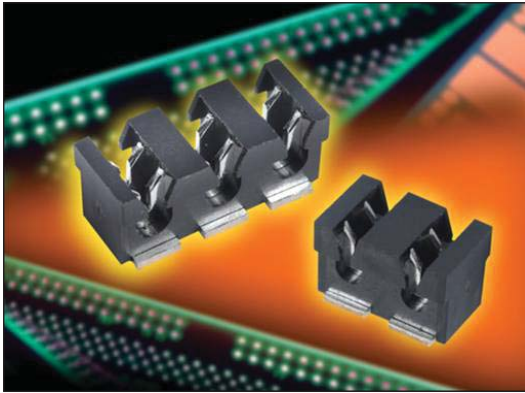

## Series 9176



The 917X series of surface mount Insulation Displacement Connectors (IDC) were developed to meet the harsh automotive and industrial market applications for connecting individual wires directly to a PCB ranging from 14 AWG to 28 AWG. This industry proven contact system has been tested to automotive levels of shock, vibration, and temperature cycling to prove their reliability and robustness. The simplicity of inserting a wire into the connector with a small tool allows a wide range of devices to be connected to the PCB without soldering. In SSL applications specifically, these connectors are used to bring power and signal onto the PCB or are used to daisy chain multiple boards together in a long string. While the IDC contact provides a gas-tight connection to conductor of the wire, the housing has been designed to grab the insulation of the wire to provide a positive strain relief even in the harshest conditions. In case of repair, the wires can be removed and replace up to three times.

The 9176 series accepts 18 AWG to 24 AWG wires with an insulation diameter ranging from 1.1mm to 2.1mm. These dual contact connectors support a 10 amp current rating with two large SMT solder tails per wire to provide maximum stability on the PCB. Available in 1p-3p configuration, these connectors can be end stackable for higher pin counts. The 9176 series also comes with optional locking strain relief caps that act as the termination tool for severe vibration applications.

### APPLICATIONS

- Connecting discrete wire components directly to the PCB
- Bringing power and signals onto a PCB
- Daisy chaining PCB's together to create a continuous string of boards
- Application Notes: refer to 201-01-124

### FEATURES AND BENEFITS

- IDC contact provides a gas-tight connection to the PCB for long term reliability
- Connector housing captures the wire insulation for positive strain relief
- Tested to automotive levels on shock, vibration and temperature cycling for reliability
- Low and high volume assembly tools to match production volumes
- Reduced total applied cost versus solder or crimp processes
- Optional thru and end caps lock in place to provide maximum strain relief
- High temperature insulator capable to 260°C reflow soldering processes

### ELECTRICAL

- Current Rating: 10 Amp / Contact
- Voltage Rating: 250 VAC

### ENVIRONMENTAL

- Operating Temperature: -40°C to +125°C

### MECHANICAL

- Insulator Material: Nylon 46: UL94V0
- Contact Material: Phosphor Bronze
- Plating: Tin over Nickel
- Durability: 3 Cycles

### HOW TO ORDER

**00**  
Prefix

**9176**  
Series

**00X**  
Number of Ways

Code	No of Ways	Details
001	1	Page 44
002	2	Page 45
003	3	Page 46

**00X**  
Wire Gauge Size

Code	Accepted Wire Gauge	Wire Insulation	Cap Code Pages 47-48
001	18 Gauge Stranded	Ø 1.6-2.1	021
011	20 Gauge Stranded	Ø 1.6-2.1	021
022	22 Gauge Stranded	Ø 1.1-1.6	016
032	24 Gauge Stranded	Ø 1.1-1.6	016

**X**  
Insulator Color

Code	Color	Application
0	Black	Industrial
1	White	Lighting

**06**  
Plating Option  
06 = Pure Tin all over

Certification: UL File #E320991



# SSL - Discrete Wire IDC



## Series 9176

### 18-24 AWG 1 WAY IDC CONNECTOR

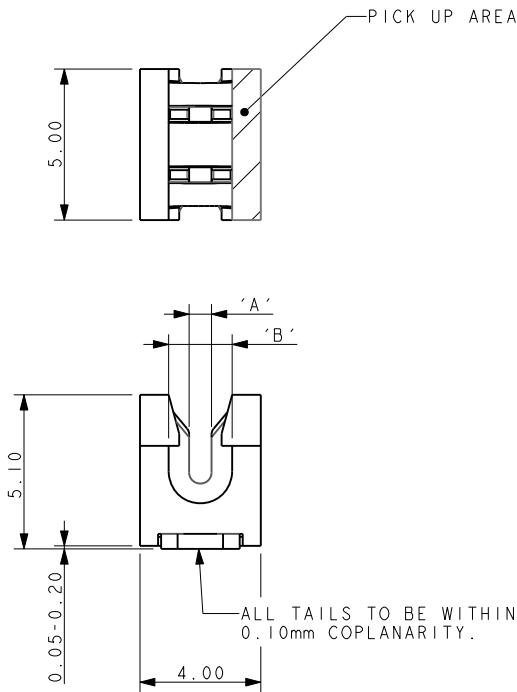

**NOTES:**

- CONNECTOR FOR IDC WIRE TO BOARD CONNECTION.
- CONTACT MATERIAL: PHOSPHORE BRONZE.  
INSULATION MATERIAL: HIGH TEMPERATURE NYLON 46.  
COLOR REFER TO PAGE 43.
- CONNECTOR DESIGNED TO ACCEPT BETWEEN 24 AND 18 GAUGE STRANDED WIRE.
- ALL DIMENSIONS FOR REFERENCE UNLESS OTHERWISE STATED.
- FOR FULL PRODUCT SPECIFICATION REFER TO ELCO SPEC 201-01-106 AND APPLICATION NOTES 201-01-124.
- FOR PCB SPACE RESTRICTED BY WIRE ASSEMBLY TOOLING REFER TO PAGE 47.
- FOR HAND WIRE ASSEMBLY TOOLING REFER TO PAGE 49.

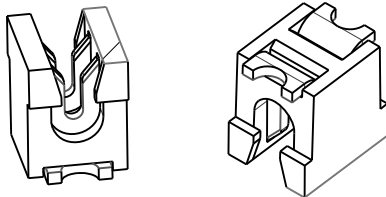
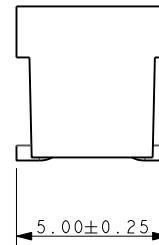

Code	Accepted Wire Gauge	A	Wire Insulation	B
001	18 Gauge Stranded	0.72	Ø 1.6-2.1	2.1
011	20 Gauge Stranded	0.60	Ø 1.6-2.1	2.1
022	22 Gauge Stranded	0.47	Ø 1.1-1.6	1.6
032	24 Gauge Stranded	0.37	Ø 1.1-1.6	1.6

### SMT PCB LAYOUT

PURE TIN PADS

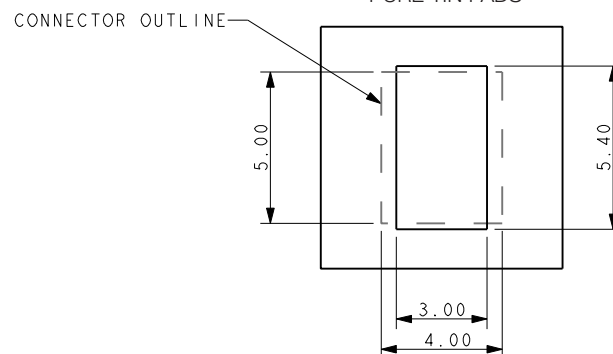

### PACKING DETAILS

REEL QTY	1000
LEADER	480MM
TRAILER	120MM

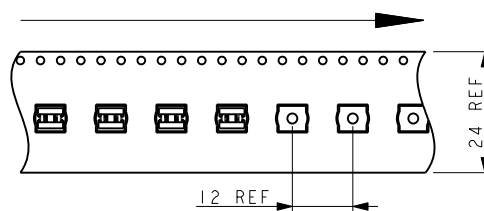
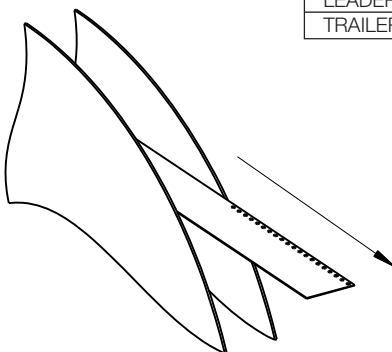

# SSL - Discrete Wire IDC



## Series 9176

### 18-24 AWG 2 WAY IDC CONNECTOR

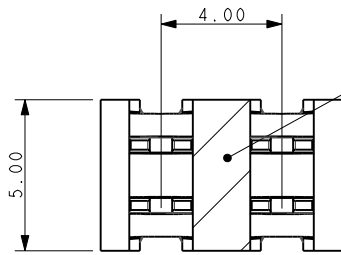

PICK UP AREA 1.9 x 5.00mm MIN

**NOTES:**

1. CONNECTOR FOR IDC WIRE TO BOARD CONNECTION.
2. CONTACT MATERIAL: PHOSPHORE BRONZE.  
INSULATION MATERIAL: HIGH TEMPERATURE NYLON 46.  
COLOR REFER TO PAGE 43.
3. CONNECTOR DESIGNED TO ACCEPT BETWEEN 24 AND 18 GAUGE STRANDED WIRE.
4. ALL DIMENSIONS FOR REFERENCE UNLESS OTHERWISE STATED.
5. FOR FULL PRODUCT SPECIFICATION REFER TO ELCO SPEC 201-01-106 AND APPLICATION NOTES 201-01-124.
6. FOR PCB SPACE RESTRICTED BY WIRE ASSEMBLY TOOLING REFER TO PAGE 47.
7. FOR HAND WIRE ASSEMBLY TOOLING REFER TO PAGE 49
8. FOR PRESS WIRE ASSEMBLY TOOLING REFER TO PAGE 50.
9. FOR ACCESSORY CAPS REFER TO PAGES 47 AND 48.

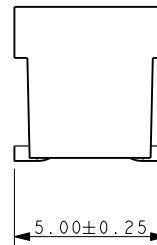
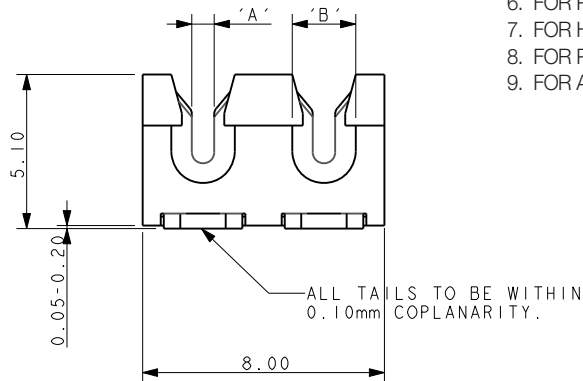

Code	Accepted Wire Gauge	A	Wire Insulation	B
001	18 Gauge Stranded	0.72	Ø 1.6-2.1	2.1
011	20 Gauge Stranded	0.60	Ø 1.6-2.1	2.1
022	22 Gauge Stranded	0.47	Ø 1.1-1.6	1.6
032	24 Gauge Stranded	0.37	Ø 1.1-1.6	1.6

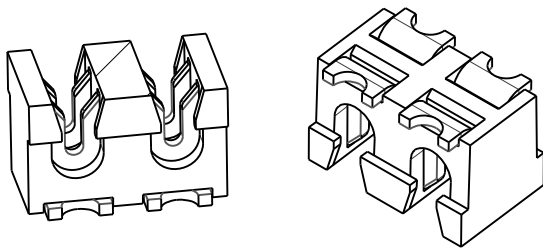

### SMT PCB LAYOUT

PURE TIN PADS

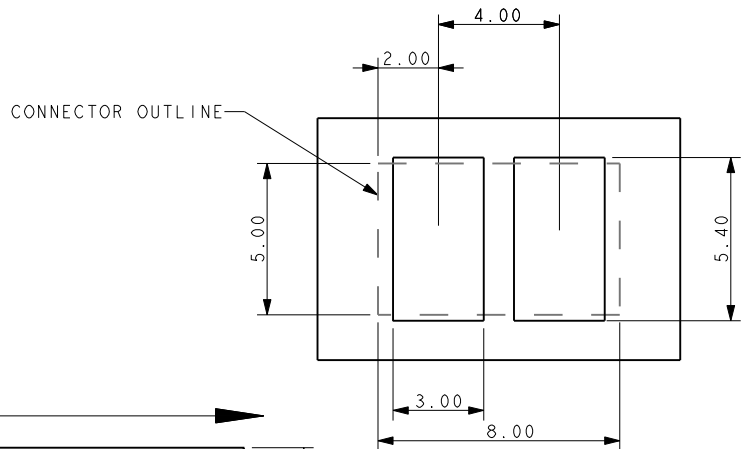

### PACKING DETAILS

REEL QTY	1000
LEADER	480MM
TRAILER	120MM

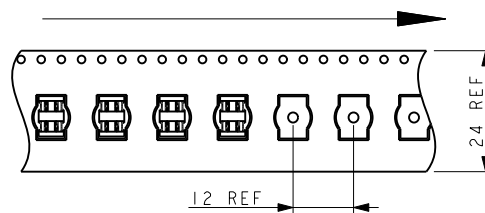
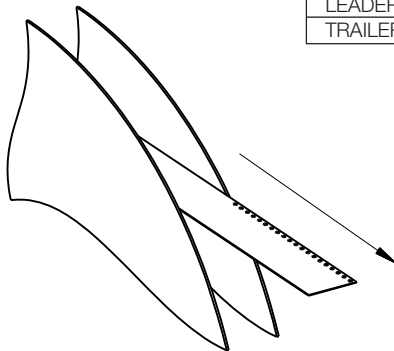

# SSL - Discrete Wire IDC



## Series 9176

### 18-24 AWG 3 WAY IDC CONNECTOR

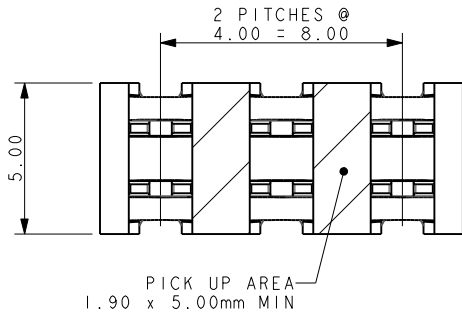

**NOTES:**

1. CONNECTOR FOR IDC WIRE TO BOARD CONNECTION.
2. CONTACT MATERIAL: PHOSPHORE BRONZE.  
INSULATION MATERIAL: HIGH TEMPERATURE NYLON 46.  
COLOR REFER TO PAGE 43.
3. CONNECTOR DESIGNED TO ACCEPT BETWEEN 24 AND 18 GAUGE STRANDED WIRE.
4. ALL DIMENSIONS FOR REFERENCE UNLESS OTHERWISE STATED.
5. FOR FULL PRODUCT SPECIFICATION REFER TO ELCO SPEC 201-01-106 AND APPLICATION NOTES 201-01-124.
6. FOR PCB SPACE RESTRICTED BY WIRE ASSEMBLY TOOLING REFER TO PAGE 47.
7. FOR HAND WIRE ASSEMBLY TOOLING REFER TO PAGE 49
8. FOR PRESS WIRE ASSEMBLY TOOLING REFER TO PAGE 50.
9. FOR ACCESSORY CAPS REFER TO PAGES 47 AND 48.

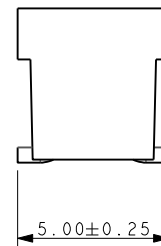
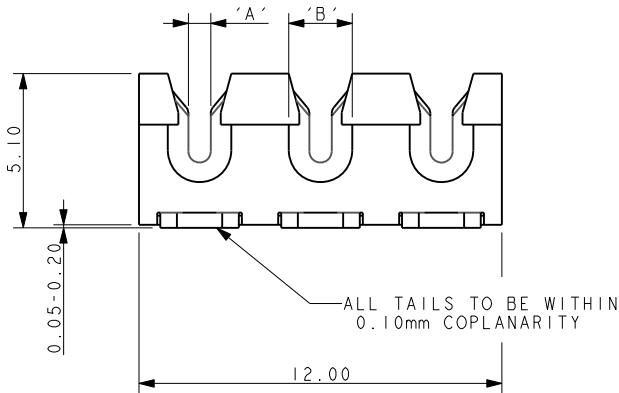

Code	Accepted Wire Gauge	A	Wire Insulation	B
001	18 Gauge Stranded	0.72	Ø 1.6-2.1	2.1
011	20 Gauge Stranded	0.60	Ø 1.6-2.1	2.1
022	22 Gauge Stranded	0.47	Ø 1.1-1.6	1.6
032	24 Gauge Stranded	0.37	Ø 1.1-1.6	1.6

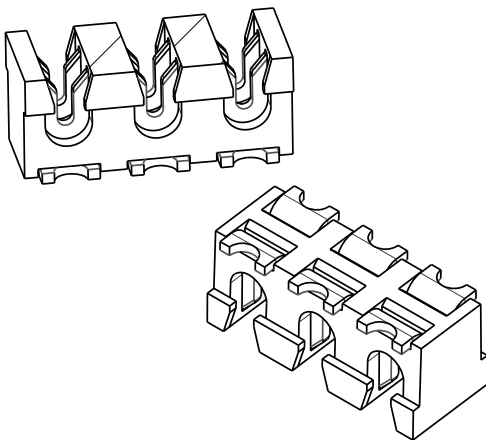

### SMT PCB LAYOUT

PURE TIN PADS

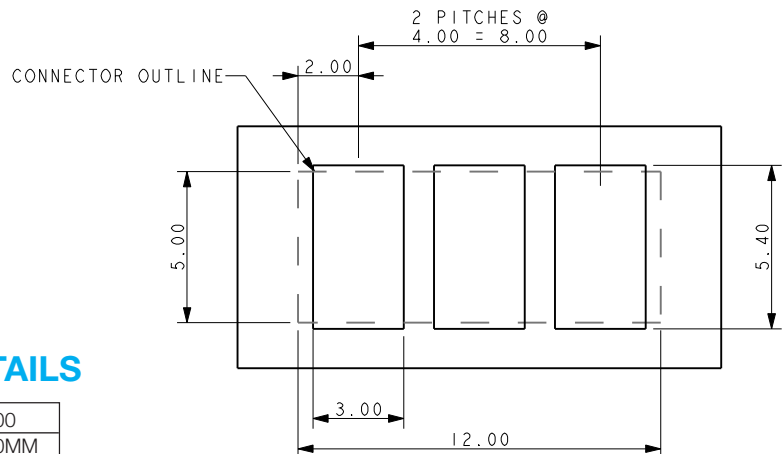

### PACKING DETAILS

REEL QTY	1000
LEADER	480MM
TRAILER	120MM

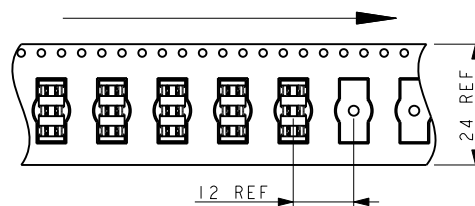
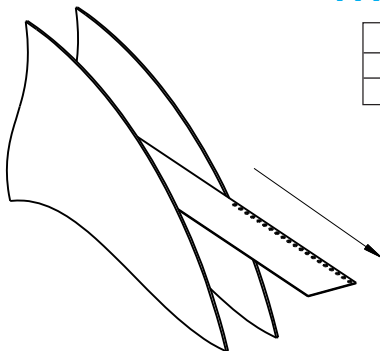

# SSL - Discrete Wire IDC



## Series 9176

60-9176-00X-0XX-X00

### ACCESSORY CAP – THROUGH WIRE

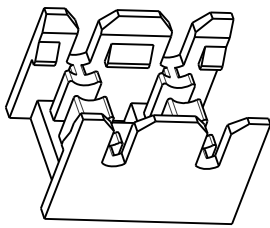
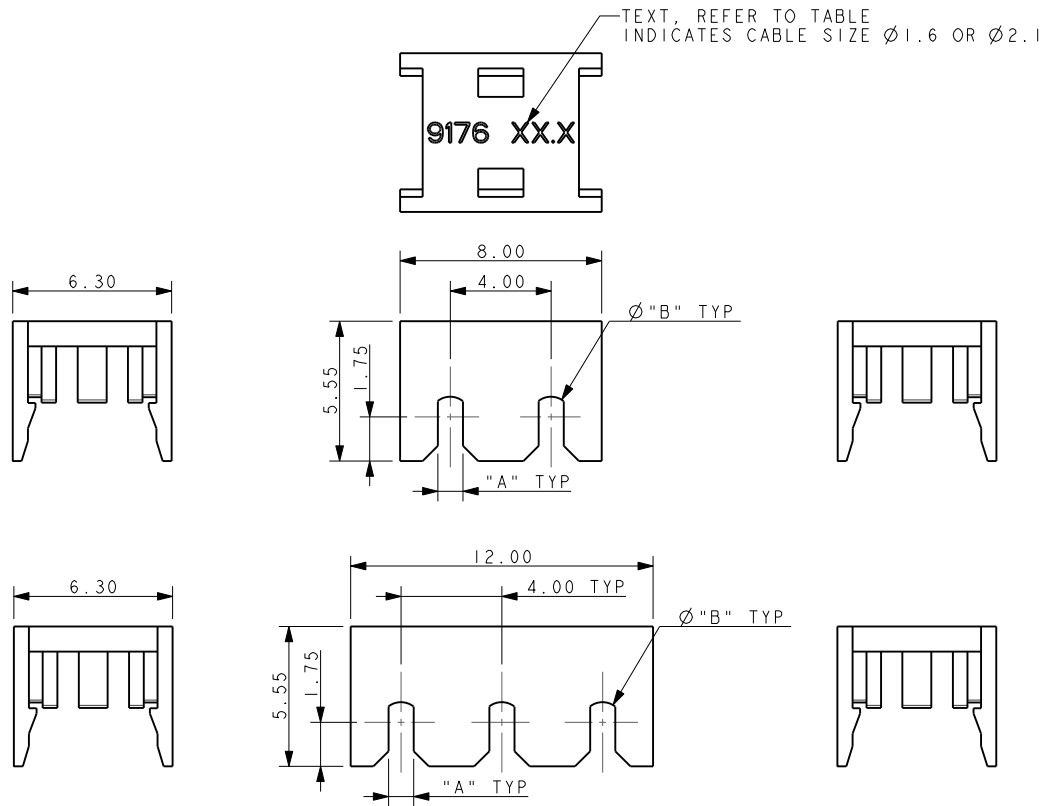

60-9176-002-016-X00

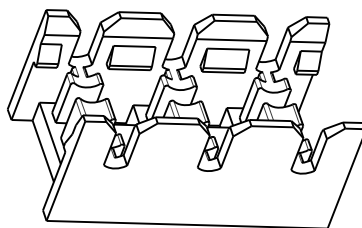

60-9176-003-016-X00

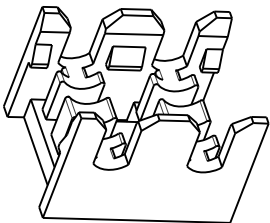

60-9176-002-021-X00

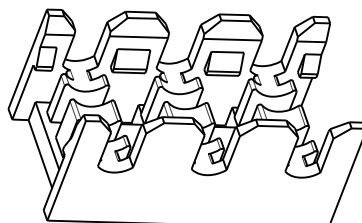

60-9176-003-021-X00

#### NOTES:

1. CAP FOR IDC WIRE TO BOARD CONNECTION, 2 AND 3 WAY, THROUGH WIRE.
2. FOR USE WITH STANDARD 9176 IDC CONNECTORS, SEE PAGE 43 FOR THE CORRECT PART CODE TO MATCH WIRE.
3. CAP MATERIAL: GLASS FILLED NYLON 46, FOR COLORS SEE TABLE BELOW.
4. DIMENSIONS A, B AND TEXT, SEE TABLE BELOW.
5. CAPS DESIGNED TO ACCOMMODATE WIRE INSULATION DIAMETERS 1.1MM TO 1.6MM AND 1.6MM TO 2.1MM.
6. ALL DIMENSIONS SHOWN ARE REFERENCE DIMENSIONS.
7. PACKED IN BAGS, 1000 PIECES PER BAG.

Code	Slot A (AWG)	Diameter B	Text
016	1.60 (22-24)	1.00	9176 $\varnothing 1.6$
021	2.10 (18-20)	1.50	9176 $\varnothing 2.1$

Color	X00
Black	000
White	100

# SSL - Discrete Wire IDC



## Series 9176

### 60-9176-00X-0XX-X99 ACCESSORY CAP - WIRE STOP

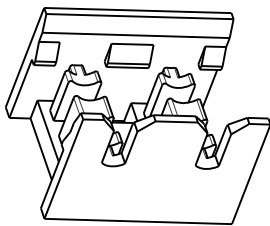
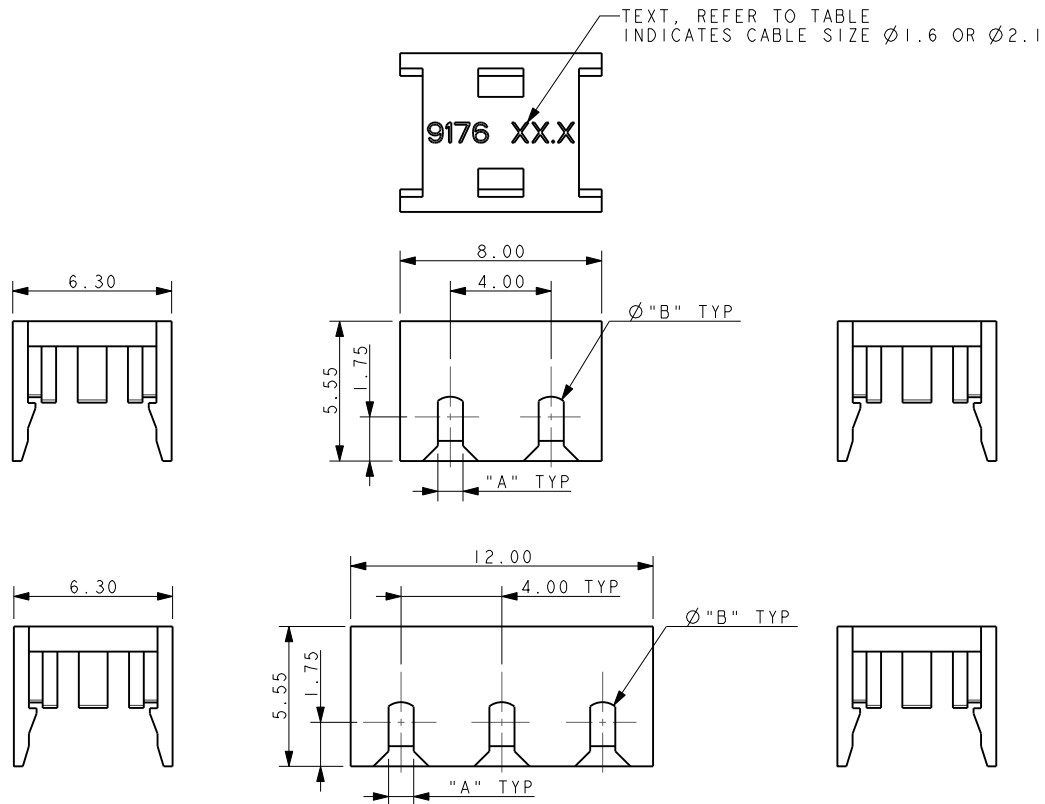

60-9176-002-016-X99

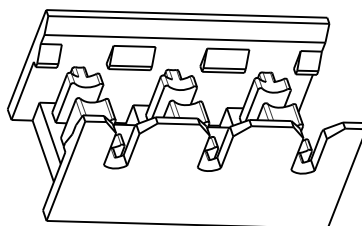

60-9176-003-016-X99

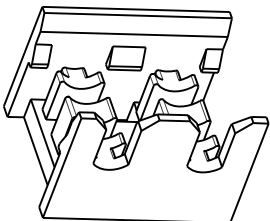

60-9176-002-021-X99

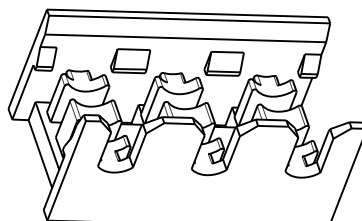

60-9176-003-021-X99

**NOTES:**

- CAP FOR IDC WIRE TO BOARD CONNECTION, 2 AND 3 WAY, WITH WIRE STOP.
- FOR USE WITH STANDARD 9176 IDC CONNECTORS, SEE PAGE 43 FOR THE CORRECT PART CODE TO MATCH WIRE.
- CAP MATERIAL: GLASS FILLED NYLON 46, FOR COLORS SEE TABLE BELOW.
- DIMENSIONS A, B AND TEXT, SEE TABLE BELOW.
- CAPS DESIGNED TO ACCOMMODATE WIRE INSULATION DIAMETERS 1.1MM TO 1.6MM AND 1.6MM TO 2.1MM.
- ALL DIMENSIONS SHOWN ARE REFERENCE DIMENSIONS.
- PACKED IN BAGS, 1000 PIECES PER BAG.

Code	Slot A (AWG)	Diameter B	Text
016	1.60 (22-24)	1.00	9176 Ø1.6
021	2.10 (18-20)	1.50	9176 Ø2.1

Color	X99
Black	099
White	199



# SSL - Discrete Wire IDC



Series 9176

## HAND INSERTION TOOLING FOR SINGLE 18/24 GAUGE WIRE

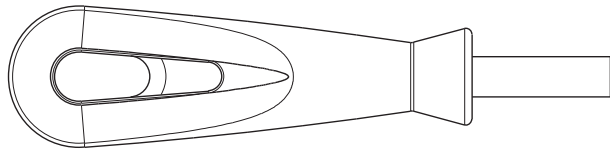

### UNIVERSAL HANDLE

Details	Tool Part Number
6.35 A/F HEX BIT HOLDER	06 7000 7730 01 000

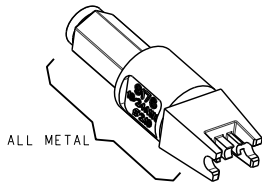

### HIGH PRODUCTION Metal

Max Insulation Dia (AWG)	Tool Part Number
2.10 (18-20)	06 9176 7017 01 000
1.60 (22-24)	06 9176 7017 02 000

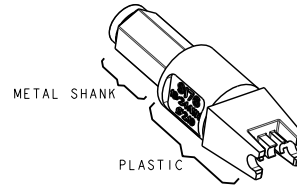

### MED PRODUCTION Metal/Plastic

Max Insulation Dia (AWG)	Tool Part Number
2.10 (18-20)	06 9176 7016 01 000
1.60 (22-24)	06 9176 7016 02 000

## CLEARANCE AREA ON PCB FOR HAND TOOLING

### 1 WAY

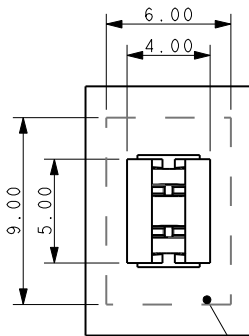

AREA TO BE KEPT CLEAR FOR TOOLING

### 2 WAY

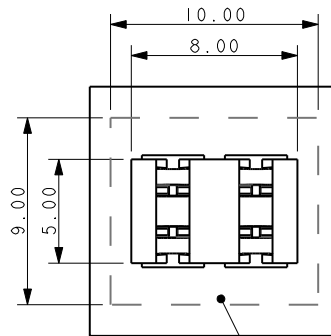

AREA TO BE KEPT CLEAR FOR TOOLING

### 3 WAY

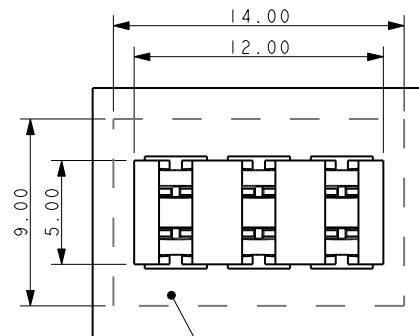

AREA TO BE KEPT CLEAR FOR TOOLING

# SSL - Discrete Wire IDC



Series 9176

## INSERTION TOOLING REQUIRES HAND PRESS WITH FLAT ROCK PLATES

2 WAY

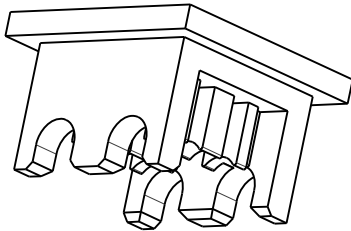

3 WAY

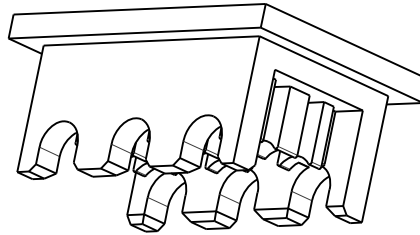

### HIGH PRODUCTION Metal

No. of Ways	Max Insulation Dia (AWG)	Tool Part Number
2	2.10 (18-20)	06 9176 7017 01 002
	1.60 (22-24)	06 9176 7017 02 002
3	2.10 (18-20)	06 9176 7017 01 003
	1.60 (22-24)	06 9176 7017 02 003

2 WAY

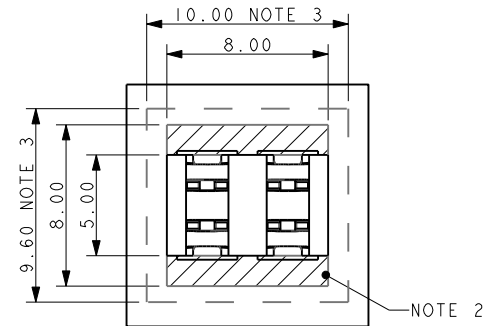
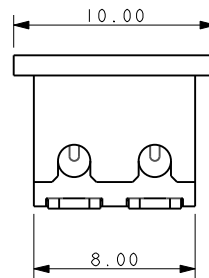
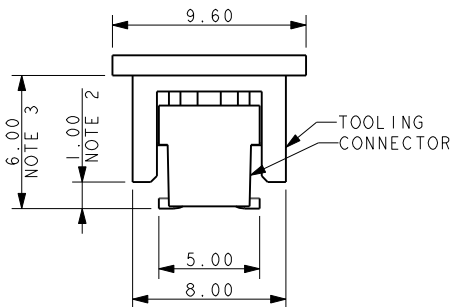

3 WAY

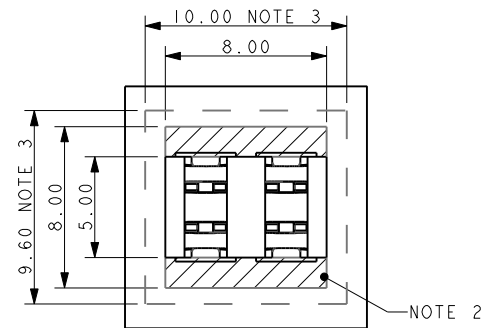
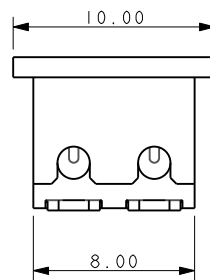
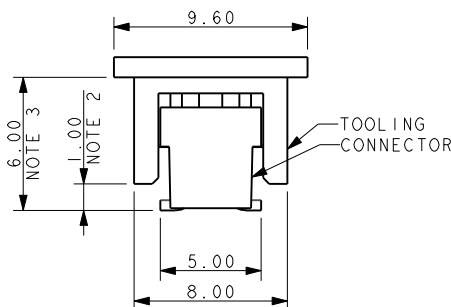

NOTES:

1. DIMENSIONS SHOWN ARE REFERENCE DIMENSIONS.
2. MAXIMUM COMPONENT HEIGHT 1.00MM IN THIS AREA.
3. MAXIMUM COMPONENT HEIGHT 6.00MM IN THIS AREA.
4. THE SAME RESTRICTIONS APPLY TO ALL WIRE INSULATION DIAMETERS
5. 2 AND 3 WAY TOOLS ONLY, FOR USE UNDER HAND PRESS WITH FLAT PLATES.
6. FOR HAND TOOLING REFER TO PAGE 47.





Компания «Океан Электроники» предлагает заключение долгосрочных отношений при поставках импортных электронных компонентов на взаимовыгодных условиях!

Наши преимущества:

- Поставка оригинальных импортных электронных компонентов напрямую с производств Америки, Европы и Азии, а так же с крупнейших складов мира;
- Широкая линейка поставок активных и пассивных импортных электронных компонентов (более 30 млн. наименований);
- Поставка сложных, дефицитных, либо снятых с производства позиций;
- Оперативные сроки поставки под заказ (от 5 рабочих дней);
- Экспресс доставка в любую точку России;
- Помощь Конструкторского Отдела и консультации квалифицированных инженеров;
- Техническая поддержка проекта, помощь в подборе аналогов, поставка прототипов;
- Поставка электронных компонентов под контролем ВП;
- Система менеджмента качества сертифицирована по Международному стандарту ISO 9001;
- При необходимости вся продукция военного и аэрокосмического назначения проходит испытания и сертификацию в лаборатории (по согласованию с заказчиком);
- Поставка специализированных компонентов военного и аэрокосмического уровня качества (Xilinx, Altera, Analog Devices, Intersil, Interpoint, Microsemi, Actel, Aeroflex, Peregrine, VPT, Syfer, Eurofarad, Texas Instruments, MS Kennedy, Miteq, Cobham, E2V, MA-COM, Hittite, Mini-Circuits, General Dynamics и др.);

Компания «Океан Электроники» является официальным дистрибьютором и эксклюзивным представителем в России одного из крупнейших производителей разъемов военного и аэрокосмического назначения «JONHON», а так же официальным дистрибьютором и эксклюзивным представителем в России производителя высокотехнологичных и надежных решений для передачи СВЧ сигналов «FORSTAR».



## JONHON

«JONHON» (основан в 1970 г.)

Разъемы специального, военного и аэрокосмического назначения:

(Применяются в военной, авиационной, аэрокосмической, морской, железнодорожной, горно- и нефтедобывающей отраслях промышленности)

«FORSTAR» (основан в 1998 г.)

ВЧ соединители, коаксиальные кабели,  
кабельные сборки и микроволновые компоненты:

(Применяются в телекоммуникациях гражданского и специального назначения, в средствах связи, РЛС, а так же военной, авиационной и аэрокосмической отраслях промышленности).



Телефон: 8 (812) 309-75-97 (многоканальный)

Факс: 8 (812) 320-03-32

Электронная почта: [ocean@oceanchips.ru](mailto:ocean@oceanchips.ru)

Web: <http://oceanchips.ru/>

Адрес: 198099, г. Санкт-Петербург, ул. Калинина, д. 2, корп. 4, лит. А