

Description

The Atmel® | SMART SAM9261 is a complete system-on-chip built around the ARM926EJ-S™ ARM® Thumb® processor with an extended DSP instruction set and Jazelle® Java® accelerator. It achieves 210 MIPS at 190 MHz.

The SAM9261 is an optimized host processor for applications with an LCD display. Its integrated LCD controller supports BW and up to 16M color, active and passive LCD displays. The 160 Kbyte integrated SRAM can be configured as a frame buffer minimizing the impact for LCD refresh on the overall processor performance. The External Bus Interface incorporates controllers for synchronous DRAM (SDRAM) and Static memories and features specific interface circuitry for CompactFlash and NAND Flash.

The SAM9261 integrates a ROM-based bootloader supporting code shadowing from, for example, external DataFlash® into external SDRAM. The software controlled Power Management Controller (PMC) keeps system power consumption to a minimum by selectively enabling/disabling the processor and various peripherals and adjustment of the operating frequency.

The SAM9261 also benefits from the integration of a wide range of debug features including JTAG-ICE, a dedicated UART debug channel (DBGU) and an embedded real time trace. This enables the development and debug of all applications, especially those with real-time constraints.

Features

- ARM926EJ-S ARM ThumbProcessor
 - DSP Instruction Extensions
 - ARM Jazelle Technology for Java Acceleration
 - 16 Kbyte Data Cache, 16 Kbyte Instruction Cache, Write Buffer
 - 210 MIPS at 190 MHz
 - Memory Management Unit
 - EmbeddedICE™, Debug Communication Channel Support
 - Mid-level implementation Embedded Trace Macrocell® (ETM®)
- Additional Embedded Memories
 - 32 Kbytes of Internal ROM, Single-cycle Access at Maximum Bus Speed
 - 160 Kbytes of Internal SRAM, Single-cycle Access at Maximum Processor or Bus Speed
- External Bus Interface (EBI)
 - Supports SDRAM, Static Memory, NAND Flash and CompactFlash®
- LCD Controller
 - Supports Passive or Active Displays
 - Up to 16 bits per Pixel in STN Color Mode
 - Up to 16M Colors in TFT Mode (24-bit per Pixel), Resolution up to 2048 x 2048
- USB 2.0 Full Speed (12 Mbits per second)
 - Host Double Port: Dual On-chip Transceivers, Integrated FIFOs and Dedicated DMA Channels
 - Device Port: On-chip Transceiver, 2 Kbyte Configurable Integrated FIFOs
- Bus Matrix
 - Handles Five Masters and Five Slaves
 - Boot Mode Select Option
 - Remap Command
- Fully Featured System Controller (SYSC) for Efficient System Management, including
 - Reset Controller, Shutdown Controller, Four 32-bit Battery Backup Registers for a Total of 16 Bytes
 - Clock Generator and Power Management Controller
 - Advanced Interrupt Controller and Debug Unit
 - Periodic Interval Timer, Watchdog Timer and Real-time Timer
 - Three 32-bit PIO Controllers
- Reset Controller (RSTC)
 - Based on Power-on Reset Cells, Reset Source Identification and Reset Output Control
- Shutdown Controller (SHDWC)
 - Programmable Shutdown Pin Control and Wakeup Circuitry
- Clock Generator (CKGR)
 - 32.768 kHz Low-power Oscillator on Battery Backup Power Supply, Providing a Permanent Slow Clock
 - 3 to 20 MHz On-chip Oscillator and two PLLs
- Power Management Controller (PMC)
 - Very Slow Clock Operating Mode, Software Programmable Power Optimization Capabilities
 - Four Programmable External Clock Signals
- Advanced Interrupt Controller (AIC)
 - Individually Maskable, Eight-level Priority, Vectored Interrupt Sources
 - Three External Interrupt Sources and One Fast Interrupt Source, Spurious Interrupt Protected

- Debug Unit (DBGU)
 - 2-wire USART and support for Debug Communication Channel, Programmable ICE Access Prevention
 - Mode for General Purpose Two-wire UART Serial Communication
- Periodic Interval Timer (PIT)
 - 20-bit Interval Timer plus 12-bit Interval Counter
- Watchdog Timer (WDT)
 - Key Protected, Programmable Only Once, Windowed 12-bit Counter, Running at Slow Clock
- Real-Time Timer (RTT)
 - 32-bit Free-running Backup Counter Running at Slow Clock
- Three 32-bit Parallel Input/Output Controllers (PIO) PIOA, PIOB and PIOC
 - 96 Programmable I/O Lines Multiplexed with up to Two Peripheral I/Os
 - Input Change Interrupt Capability on Each I/O Line
 - Individually Programmable Open-drain, Pull-up Resistor and Synchronous Output
- Nineteen Peripheral DMA (PDC) Channels
- Multimedia Card Interface (MCI)
 - SDCard and MultiMediaCard™ Compliant
 - Automatic Protocol Control and Fast Automatic Data Transfers with PDC, MMC and SDCard Compliant
- Three Synchronous Serial Controllers (SSC)
 - Independent Clock and Frame Sync Signals for Each Receiver and Transmitter
 - I²S Analog Interface Support, Time Division Multiplex Support
 - High-speed Continuous Data Stream Capabilities with 32-bit Data Transfer
- Three Universal Synchronous/Asynchronous Receiver Transmitters (USART)
 - Individual Baud Rate Generator, IrDA® Infrared Modulation/Demodulation
 - Support for ISO7816 T0/T1 Smart Card, Hardware and Software Handshaking, RS485 Support
- Two Master/Slave Serial Peripheral Interface (SPI)
 - 8 to 16-bit Programmable Data Length, Four External Peripheral Chip Selects
- One Three-channel 16-bit Timer/Counters (TC)
 - Three External Clock Inputs, Two multi-purpose I/O Pins per Channel
 - Double PWM Generation, Capture/Waveform Mode, Up/Down Capability
- Two-wire Interface (TWI)
 - Master Mode Support, All Two-wire Atmel EEPROMs Supported
- IEEE® 1149.1 JTAG Boundary Scan on All Digital Pins
- Package
 - LFBGA217, 217-ball LFBGA, 15 x 15 mm, pitch 0.8mm

1. Block Diagram

Figure 1-1. SAM9261 Block Diagram

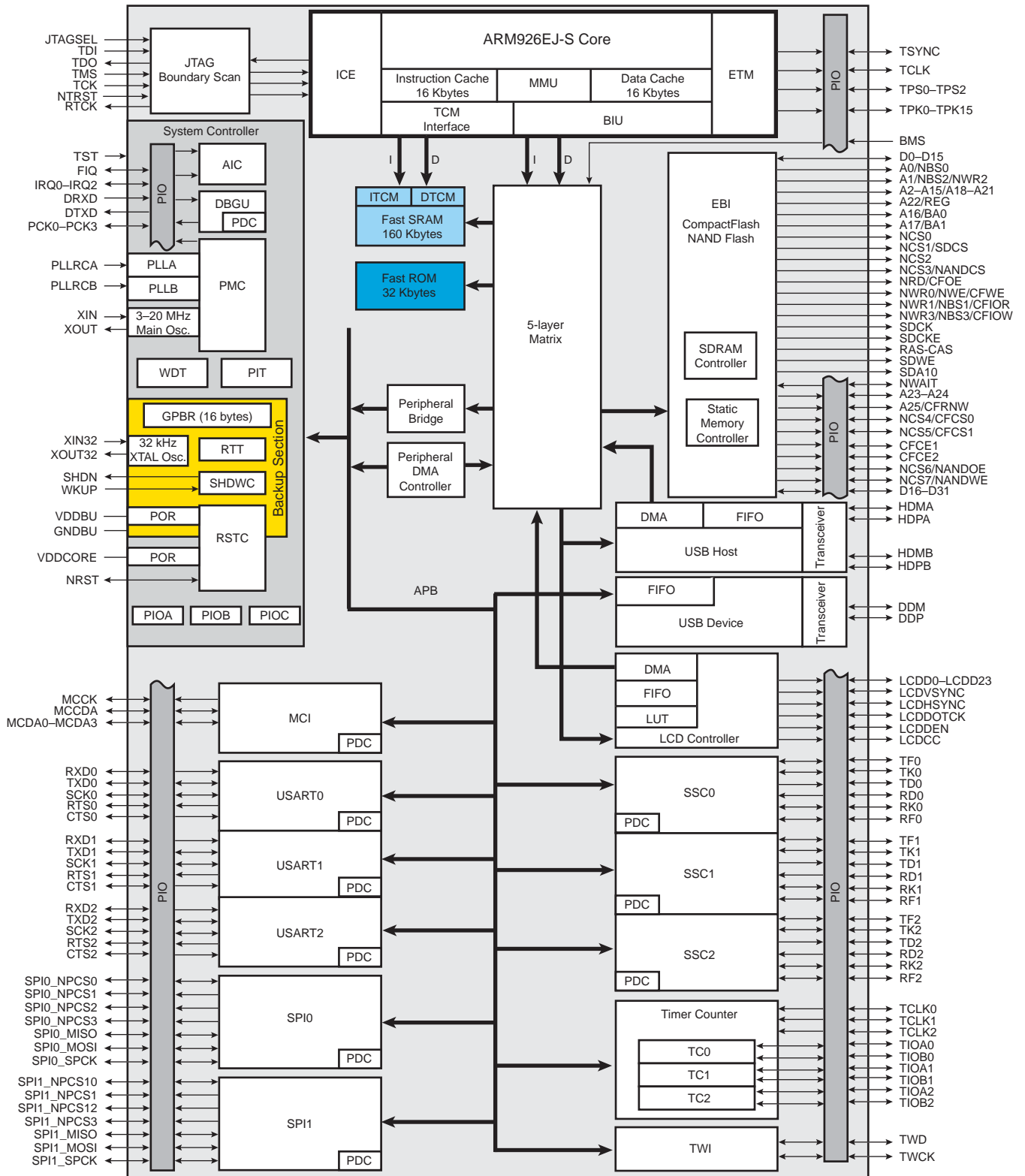

2. Signal Description

Table 2-1. Signal Description by Peripheral

| Signal Name | Function | Type | Active Level | Comments |
|---------------------------------------|------------------------------------|--------|--------------|--|
| Power | | | | |
| VDDIOM | EBI I/O Lines Power Supply | Power | | 1.65–1.95 V and 3.0–3.6 V |
| VDDIOP | Peripherals I/O Lines Power Supply | Power | | 2.7–3.6 V |
| VDDDBU | Backup I/O Lines Power Supply | Power | | 1.08–1.32 V |
| VDDPLL | PLL Power Supply | Power | | 3.0–3.6 V |
| VDDOSC | Oscillator Power Supply | Power | | 3.0–3.6 V |
| VDDCORE | Core Chip Power Supply | Power | | 1.08–1.32 V |
| GND | Ground | Ground | | |
| GNDPLL | PLL Ground | Ground | | |
| GNDOSC | Oscillator Ground | Ground | | |
| GNDDBU | Backup Ground | Ground | | |
| Clocks, Oscillators and PLLs | | | | |
| XIN | Main Oscillator Input | Input | | |
| XOUT | Main Oscillator Output | Output | | |
| XIN32 | Slow Clock Oscillator Input | Input | | |
| XOUT32 | Slow Clock Oscillator Output | Output | | |
| PLLRC A | PLL Filter | Input | | |
| PLLRC B | PLL Filter | Input | | |
| PCK0–PCK3 | Programmable Clock Output | Output | | |
| Shutdown, Wakeup Logic | | | | |
| SHDN | Shutdown Control | Output | | Do not tie over VDDDBU |
| WKUP | Wakeup Input | Input | | Accepts between 0V and VDDDBU |
| ICE and JTAG | | | | |
| TCK | Test Clock | Input | | No pull-up resistor |
| RTCK | Returned Test Clock | Output | | No pull-up resistor |
| TDI | Test Data In | Input | | No pull-up resistor |
| TDO | Test Data Out | Output | | |
| TMS | Test Mode Select | Input | | No pull-up resistor |
| NTRST | Test Reset Signal | Input | Low | Pull-up resistor |
| JTAGSEL | JTAG Selection | Input | | Pull-down resistor. Accepts between 0V and VDDDBU. |
| Embedded Trace Macrocell - ETM | | | | |
| TSYNC | Trace Synchronization Signal | Output | | |
| TCLK | Trace Clock | Output | | |
| TPS0–TPS2 | Trace ARM Pipeline Status | Output | | |
| TPK0–TPK15 | Trace Packet Port | Output | | |

Table 2-1. Signal Description by Peripheral (Continued)

| Signal Name | Function | Type | Active Level | Comments |
|--|--------------------------------|--------|--------------|--------------------------|
| Reset/Test | | | | |
| NRST | Microcontroller Reset | I/O | Low | Pull-up resistor |
| TST | Test Mode Select | Input | | Pull-down resistor |
| BMS | Boot Mode Select | Input | | |
| Debug Unit - DBGU | | | | |
| DRXD | Debug Receive Data | Input | | |
| DTXD | Debug Transmit Data | Output | | |
| Advanced Interrupt Controller - AIC | | | | |
| IRQ0–IRQ2 | External Interrupt Inputs | Input | | |
| FIQ | Fast Interrupt Input | Input | | |
| PIO Controller - PIOA / PIOB / PIOC | | | | |
| PA0–PA31 | Parallel IO Controller A | I/O | | Pulled up input at reset |
| PB0–PB31 | Parallel IO Controller B | I/O | | Pulled up input at reset |
| PC0–PC31 | Parallel IO Controller C | I/O | | Pulled up input at reset |
| External Bus Interface - EBI | | | | |
| D0–D31 | Data Bus | I/O | | Pulled up input at reset |
| A0–A25 | Address Bus | Output | | 0 at reset |
| NWAIT | External Wait Signal | Input | Low | |
| Static Memory Controller - SMC | | | | |
| NCS0–NCS7 | Chip Select Lines | Output | Low | |
| NWR0–NWR3 | Write Signal | Output | Low | |
| NRD | Read Signal | Output | Low | |
| NWE | Write Enable | Output | Low | |
| NBS0–NBS3 | Byte Mask Signal | Output | Low | |
| CompactFlash Support | | | | |
| CFCE1–CFCE2 | CompactFlash Chip Enable | Output | Low | |
| CFOE | CompactFlash Output Enable | Output | Low | |
| CFWE | CompactFlash Write Enable | Output | Low | |
| CFIOR | CompactFlash IO Read | Output | Low | |
| CFIOW | CompactFlash IO Write | Output | Low | |
| CFRNW | CompactFlash Read Not Write | Output | | |
| CFCS0–CFCS1 | CompactFlash Chip Select Lines | Output | Low | |
| NAND Flash Support | | | | |
| NANDOE | NAND Flash Output Enable | Output | Low | |
| NANDWE | NAND Flash Write Enable | Output | Low | |
| NANDCS | NAND Flash Chip Select | Output | Low | |

Table 2-1. Signal Description by Peripheral (Continued)

| Signal Name | Function | Type | Active Level | Comments |
|--|------------------------------|--------|--------------|----------|
| SDRAM Controller - SDRAMC | | | | |
| SDCK | SDRAM Clock | Output | | |
| SDCKE | SDRAM Clock Enable | Output | High | |
| SDCS | SDRAM Controller Chip Select | Output | Low | |
| BA0–BA1 | Bank Select | Output | | |
| SDWE | SDRAM Write Enable | Output | Low | |
| RAS - CAS | Row and Column Signal | Output | Low | |
| SDA10 | SDRAM Address 10 Line | Output | | |
| Multimedia Card Interface - MCI | | | | |
| MCKK | Multimedia Card Clock | Output | | |
| MCCDA | Multimedia Card A Command | I/O | | |
| MCDA0–MCDA3 | Multimedia Card A Data | I/O | | |
| Universal Synchronous Asynchronous Receiver Transmitter - USART | | | | |
| SCK0–SCK2 | Serial Clock | I/O | | |
| TXD0–TXD2 | Transmit Data | Output | | |
| RXD0–RXD2 | Receive Data | Input | | |
| RTS0–RTS2 | Request To Send | Output | | |
| CTS0–CTS2 | Clear To Send | Input | | |
| Synchronous Serial Controller - SSC | | | | |
| TD0–TD2 | Transmit Data | Output | | |
| RD0–RD2 | Receive Data | Input | | |
| TK0–TK2 | Transmit Clock | I/O | | |
| RK0–RK2 | Receive Clock | I/O | | |
| TF0–TF2 | Transmit Frame Sync | I/O | | |
| RF0–RF2 | Receive Frame Sync | I/O | | |
| Timer/Counter - TC | | | | |
| TCLK0–TCLK2 | External Clock Input | Input | | |
| TIOA0–TIOA2 | I/O Line A | I/O | | |
| TIOB0–TIOB2 | I/O Line B | I/O | | |
| Serial Peripheral Interface - SPI | | | | |
| SPI0_MISO, SPI1_MISO | Master In Slave Out | I/O | | |
| SPI0_MOSI, SPI1_MOSI | Master Out Slave In | I/O | | |
| SPI0_SPCK, SPI1_SPCK | SPI Serial Clock | I/O | | |
| SPI0_NPCS0, SPI1_NPCS0 | SPI Peripheral Chip Select 0 | I/O | Low | |
| SPI0_NPCS1–SPI0_NPCS3, SPI1_NPCS1–SPI1_NPCS3 | SPI Peripheral Chip Select | Output | Low | |

Table 2-1. Signal Description by Peripheral (Continued)

| Signal Name | Function | Type | Active Level | Comments |
|---------------------------------|--------------------------------|--------|--------------|----------|
| Two-Wire Interface - TWI | | | | |
| TWD | Two-wire Serial Data | I/O | | |
| TWCK | Two-wire Serial Clock | I/O | | |
| LCD Controller - LCDC | | | | |
| LCDD0-LCDD23 | LCD Data Bus | Output | | |
| LCDVSYNC | LCD Vertical Synchronization | Output | | |
| LCDHSYNC | LCD Horizontal Synchronization | Output | | |
| LCDDOTCK | LCD Dot Clock | Output | | |
| LCDDEN | LCD Data Enable | Output | | |
| LCDDCC | LCD Contrast Control | Output | | |
| USB Device Port - UDP | | | | |
| DDM | USB Device Port Data - | Analog | | |
| DDP | USB Device Port Data + | Analog | | |
| USB Host Port - UHP | | | | |
| HDMA | USB Host Port A Data - | Analog | | |
| HDP A | USB Host Port A Data + | Analog | | |
| HDMB | USB Host Port B Data - | Analog | | |
| HDPB | USB Host Port B Data + | Analog | | |

3. Package and Pinout

3.1 217-ball LFBGA Package Outline

Figure 3-1 shows the orientation of the 217-ball LFBGA package.

A detailed mechanical description is given in Section 39. “Mechanical Characteristics”.

Figure 3-1. 217-ball LFBGA Package Outline (Top View)

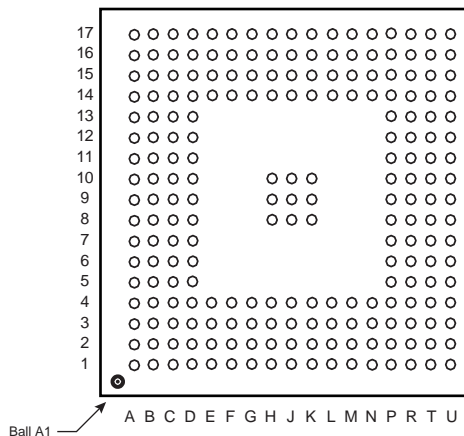

3.2 Pinout

Table 3-1. SAM9261 Pinout for 217-ball LFBGA Package

| Pin ⁽¹⁾ | Signal Name | Pin ⁽¹⁾ | Signal Name | Pin ⁽¹⁾ | Signal Name | Pin ⁽¹⁾ | Signal Name |
|--------------------|-------------------|--------------------|-------------------|--------------------|-------------|--------------------|-------------|
| A1 | A19 | D5 | VDDCORE | J14 | VDDIOP | P17 | PA20 |
| A2 | A16/BA0 | D6 | A10 | J15 | PB9 | R1 | PC19 |
| A3 | A14 | D7 | A5 | J16 | PB6 | R2 | PC21 |
| A4 | A12 | D8 | A0/NBS0 | J17 | PB4 | R3 | GND |
| A5 | A9 | D9 | SHDN | K1 | D6 | R4 | PC27 |
| A6 | A6 | D10 | NC ⁽²⁾ | K2 | D8 | R5 | PC29 |
| A7 | A3 | D11 | VDDIOP | K3 | D10 | R6 | PC4 |
| A8 | A2 | D12 | PB29 | K4 | D7 | R7 | PC8 |
| A9 | NC ⁽²⁾ | D13 | PB28 | K8 | GND | R8 | PC12 |
| A10 | XOUT32 | D14 | PB23 | K9 | GND | R9 | PC14 |
| A11 | XIN32 | D15 | PB20 | K10 | GND | R10 | VDDPLL |
| A12 | DDP | D16 | PB17 | K14 | VDDCORE | R11 | PA0 |
| A13 | HDPB | D17 | TCK | K15 | PB3/BMS | R12 | PA7 |
| A14 | HDMB | E1 | NWR1/NBS1/CFIOR | K16 | PB1 | R13 | PA10 |
| A15 | PB27 | E2 | NWR0/NWE/CFWE | K17 | PB2 | R14 | PA13 |
| A16 | GND | E3 | NRD/CFOE | L1 | D9 | R15 | PA17 |
| A17 | PB24 | E4 | SDA10 | L2 | D11 | R16 | GND |
| B1 | A20 | E14 | PB22 | L3 | D12 | R17 | PA18 |
| B2 | A18 | E15 | PB18 | L4 | VDDIOM | T1 | PC20 |
| B3 | A15 | E16 | PB15 | L14 | PA30 | T2 | PC23 |
| B4 | A13 | E17 | TDI | L15 | PA27 | T3 | PC26 |
| B5 | A11 | F1 | SDCKE | L16 | PA31 | T4 | PC2 |
| B6 | A7 | F2 | RAS | L17 | PB0 | T5 | VDDIOP |
| B7 | A4 | F3 | NWR3/NBS3/CFIOW | M1 | D13 | T6 | PC5 |

Table 3-1. SAM9261 Pinout for 217-ball LFBGA Package (Continued)

| Pin ⁽¹⁾ | Signal Name | Pin ⁽¹⁾ | Signal Name | Pin ⁽¹⁾ | Signal Name | Pin ⁽¹⁾ | Signal Name |
|--------------------|-------------------|--------------------|-------------|--------------------|-------------|--------------------|-------------|
| B8 | A1/NBS2/NWR2 | F4 | NCS0 | M2 | D15 | T7 | PC9 |
| B9 | VDDBU | F14 | PB16 | M3 | PC18 | T8 | PC10 |
| B10 | JTAGSEL | F15 | NRST | M4 | VDDCORE | T9 | PC15 |
| B11 | WKUP | F16 | TDO | M14 | PA25 | T10 | VDDOSC |
| B12 | DDM | F17 | NTRST | M15 | PA26 | T11 | GNDOSC |
| B13 | PB31 | G1 | D0 | M16 | PA28 | T12 | PA1 |
| B14 | HDMA | G2 | D1 | M17 | PA29 | T13 | PA4 |
| B15 | PB26 | G3 | SDWE | N1 | D14 | T14 | PA6 |
| B16 | PB25 | G4 | NCS3/NANDCS | N2 | PC17 | T15 | PA8 |
| B17 | PB19 | G14 | PB14 | N3 | PC31 | T16 | PA11 |
| C1 | A22 | G15 | PB12 | N4 | VDDIOM | T17 | PA14 |
| C2 | A21 | G16 | PB11 | N14 | PA22 | U1 | PC25 |
| C3 | VDDIOM | G17 | PB8 | N15 | PA21 | U2 | PC0 |
| C4 | A17/BA1 | H1 | D2 | N16 | PA23 | U3 | PC3 |
| C5 | VDDIOM | H2 | D3 | N17 | PA24 | U4 | GND |
| C6 | A8 | H3 | VDDIOM | P1 | PC16 | U5 | PC6 |
| C7 | GND | H4 | SDCK | P2 | PC30 | U6 | VDDIOP |
| C8 | VDDIOM | H8 | GND | P3 | PC22 | U7 | GND |
| C9 | GNDBU | H9 | GND | P4 | PC24 | U8 | PC13 |
| C10 | TST | H10 | GND | P5 | PC28 | U9 | PLLRCB |
| C11 | GND | H14 | PB10 | P6 | PC1 | U10 | PLLRCA |
| C12 | HDPA | H15 | PB13 | P7 | PC7 | U11 | XIN |
| C13 | PB30 | H16 | PB7 | P8 | PC11 | U12 | XOUT |
| C14 | NC ⁽²⁾ | H17 | PB5 | P9 | GNDPLL | U13 | PA2 |
| C15 | VDDIOP | J1 | D4 | P10 | PA3 | U14 | PA5 |
| C16 | PB21 | J2 | D5 | P11 | VDDIOP | U15 | PA12 |
| C17 | TMS | J3 | GND | P12 | VDDCORE | U16 | PA9 |
| D1 | NCS2 | J4 | CAS | P13 | PA15 | U17 | RTCK |
| D2 | NCS1/SDCS | J8 | GND | P14 | PA16 | | |
| D3 | GND | J9 | GND | P15 | VDDIOP | | |
| D4 | VDDIOM | J10 | GND | P16 | PA19 | | |

Note: 1. Shaded cells define the pins powered by VDDIOM.
 2. NC pins must be left unconnected.

4. Power Considerations

4.1 Power Supplies

The SAM9261 device has several types of power supply pins. Some supply pins share common ground (GND) pins whereas others have separate grounds. See [Table 4-1](#).

Table 4-1. SAM9263 Power Supply Pins

| Pin(s) | Item(s) powered | Range | Nominal | Ground |
|---------|---|----------------------------|---------|--------|
| VDDCORE | Core, including the processor Embedded memories Peripherals | 1.08–1.32 V | 1.2V | GND |
| VDDIOM | External Bus Interface I/O lines | 1.65–1.95 V ⁽¹⁾ | 1.8V | |
| | | 3.0–3.6 V ⁽¹⁾ | 3.3V | |
| VDDIOP | Peripheral I/O lines USB transceivers | 2.7–3.6 V | 3.3V | |
| VDDOSC | Main oscillator cells | 3.0–3.6 V | 3.3V | GNDOSC |
| VDDBU | Slow Clock oscillator Part of the System Controller | 1.08–1.32 V | 1.2V | GNDBU |
| VDDPLL | PLL cells | 3.0–3.6 V | 3.3V | GNDPLL |

Note: 1. Desired voltage range selectable by software

The double power supplies VDDIOM and VDDIOP are identified in [Table 3-1 on page 9](#). These supplies enable the user to power the device differently for interfacing with memories and for interfacing with peripherals.

4.2 Power Sequence Requirements

The SAM9261 board design must comply with the guidelines described in [Section 4.2.1 “Powerup Sequence”](#) and [Section 4.2.2 “Powerdown Sequence”](#) to guarantee reliable operation of the device. Any deviation from these sequences may prevent the device from booting.

4.2.1 Powerup Sequence

Figure 4-1. VDDCORE and VDDIO Constraints at Startup

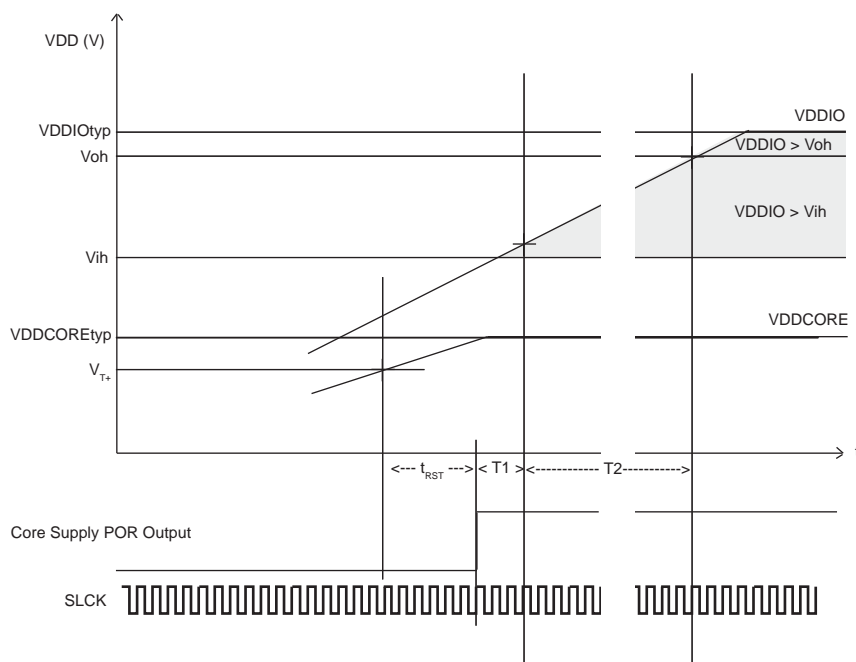

VDDCORE and VDDBU are controlled by internal POR (Power-On-Reset) to guarantee that these power sources reach their target values prior to the release of POR.

- VDDIOP must be \geq to V_{IH} (refer to [Table 38-2 “DC Characteristics”](#) for more details) within $(t_{RST} + T1)$ after VDDCORE has reached V_{T+} .
- VDDIOM must reach V_{OH} (refer to [Table 38-2 “DC Characteristics”](#) for more details) within $(t_{RST} + T1 + T2)$ after VDDCORE has reached V_{T+} .
 - t_{RST} is a POR characteristic
 - $T1 = 3 \times t_{SLCK}$
 - $T2 = 16 \times t_{SLCK}$

As t_{SLCK} is the period of the external 32.768 kHz oscillator.

- $t_{RST} = 50 \mu s$
- $T1 = 91.5 \mu s$
- $T2 = 488 \mu s$

4.2.2 Powerdown Sequence

Switch off the VDDIOM and VDDIOP power supply prior to or at the same time as VDDCORE. No powerup or powerdown restrictions apply to other power supplies.

5. I/O Line Considerations

5.1 JTAG Port Pins

TMS, TDI and TCK are Schmitt trigger inputs and have no pull-up resistors.

TDO and RTCK are outputs, driven at up to VDDIOP, and have no pull-up resistor.

The JTAGSEL pin is used to select the JTAG boundary scan when asserted at a high level (tied to VDDBU). It integrates a permanent pull-down resistor of about 15 k Ω to GNDBU, so that it can be left unconnected for normal operations.

The NTRST pin is used to initialize the embedded ICE TAP Controller when asserted at a low level. It integrates a permanent pull-up resistor of about 15 k Ω to VDDIOP, so that it can be left unconnected for normal operations.

5.2 Test Pin

The TST pin is used for manufacturing test purposes when asserted high. It integrates a permanent pull-down resistor of about 15 k Ω to GNDBU, so that it can be left unconnected for normal operations. Driving this line at a high level leads to unpredictable results.

5.3 Reset Pin

NRST is an open-drain output integrating a non-programmable pull-up resistor. It can be driven with voltage at up to VDDIOP. As the product integrates power-on reset cells, the NRST pin can be left unconnected in case no reset from the system needs to be applied to the product.

The NRST pin integrates a permanent pull-up resistor of 100 k Ω minimum to VDDIOP.

The NRST signal is inserted in the Boundary Scan.

5.4 PIO Controller A, B and C Lines

All the I/O lines PA0 to PA31, PB0 to PB31, and PC0 to PC31 integrate a programmable pull-up resistor of 100 k Ω . Programming of this pull-up resistor is performed independently for each I/O line through the PIO Controllers.

After reset, all the I/O lines default as inputs with pull-up resistors enabled, except those which are multiplexed with the External Bus Interface signals that require to be enabled as Peripherals at reset. This is explicitly indicated in the column "Reset State" of the PIO Controller multiplexing tables.

5.5 Shutdown Logic Pins

The SHDN pin is an output only, driven by Shutdown Controller.

The pin WKUP is an input only. It can accept voltages only between 0V and VDDBU.

6. Processor and Architecture

6.1 ARM926EJ-S Processor

- RISC Processor Based on ARM v5TEJ Architecture with Jazelle technology for Java acceleration
- Two Instruction Sets
 - ARM High-performance 32-bit Instruction Set
 - Thumb High Code Density 16-bit Instruction Set
- DSP Instruction Extensions
- 5-Stage Pipeline Architecture:
 - Instruction Fetch (F)
 - Instruction Decode (D)
 - Execute (E)
 - Data Memory (M)
 - Register Write (W)
- 16 Kbyte Data Cache, 16 Kbyte Instruction Cache
 - Virtually-addressed 4-way Associative Cache
 - Eight words per line
 - Write-through and Write-back Operation
 - Pseudo-random or Round-robin Replacement
- Write Buffer
 - Main Write Buffer with 16-word Data Buffer and 4-address Buffer
 - DCache Write-back Buffer with 8-word Entries and a Single Address Entry
 - Software Control Drain
- Standard ARM v4 and v5 Memory Management Unit (MMU)
 - Access Permission for Sections
 - Access Permission for large pages and small pages can be specified separately for each quarter of the page
 - 16 embedded domains
- Bus Interface Unit (BIU)
 - Arbitrates and Schedules AHB Requests
 - Separate Masters for both instruction and data access providing complete AHB system flexibility
 - Separate Address and Data Buses for both the 32-bit instruction interface and the 32-bit data interface
 - On Address and Data Buses, data can be 8-bit (Bytes), 16-bit (Half-words) or 32-bit (Words)

6.2 Debug and Test Features

- Integrated Embedded In-circuit Emulator Real-Time
 - Two real-time Watchpoint Units
 - Two Independent Registers: Debug Control Register and Debug Status Register
 - Test Access Port Accessible through JTAG Protocol
 - Debug Communications Channel
- Debug Unit
 - Two-pin UART
 - Debug Communication Channel Interrupt Handling
 - Chip ID Register
- Embedded Trace Macrocell: ETM9™
 - Medium+ Level Implementation
 - Half-rate Clock Mode
 - Four Pairs of Address Comparators
 - Two Data Comparators
 - Eight Memory Map Decoder Inputs
 - Two 16-bit Counters
 - One 3-stage Sequencer
 - One 45-byte FIFO
- IEEE1149.1 JTAG Boundary-scan on All Digital Pins

6.3 Bus Matrix

- Five Masters and Five Slaves handled
 - Handles Requests from the ARM926EJ-S, USB Host Port, LCD Controller and the Peripheral DMA Controller to internal ROM, internal SRAM, EBI, APB, LCD Controller and USB Host Port.
 - Round-Robin Arbitration (three modes supported: no default master, last accessed default master, fixed default master)
 - Burst Breaking with Slot Cycle Limit
- One Address Decoder Provided per Master
 - Three different slaves may be assigned to each decoded memory area: one for internal boot, one for external boot, one after remap.
- Boot Mode Select Option
 - Non-volatile Boot Memory can be Internal or External.
 - Selection is made by BMS pin sampled at reset.
- Remap Command
 - Allows Remapping of an Internal SRAM in Place of the Boot Non-volatile Memory
 - Allows Handling of Dynamic Exception Vectors

6.4 Peripheral DMA Controller

- Transfers from/to peripheral to/from any memory space without intervention of the processor.
- Next Pointer Support, forbids strong real-time constraints on buffer management.
- Nineteen channels
 - Two for each USART
 - Two for the Debug Unit
 - Two for each Serial Synchronous Controller
 - Two for each Serial Peripheral Interface
 - One for the Multimedia Card Interface

7. Memories

Figure 7-1. SAM9261 Memory Mapping

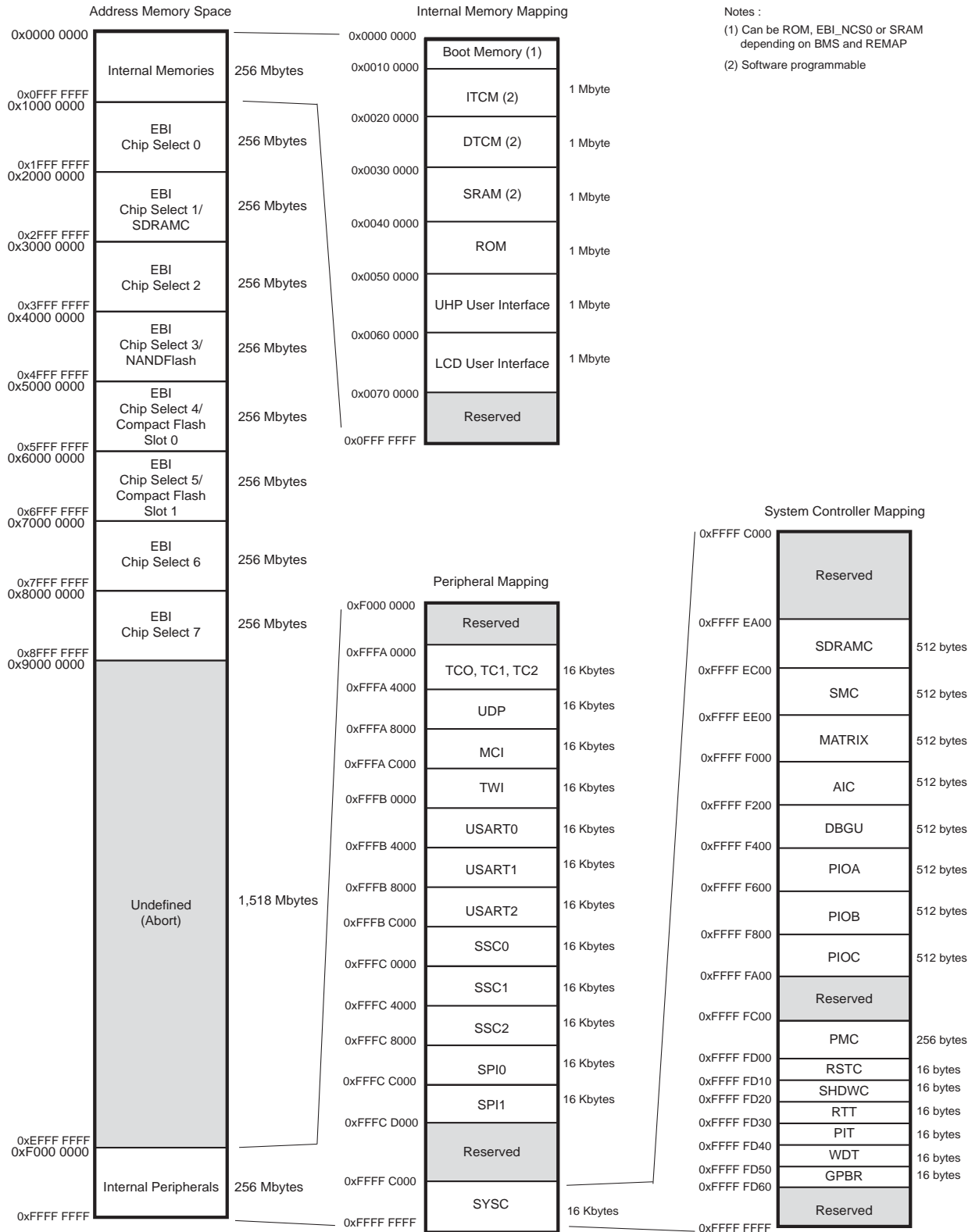

A first level of address decoding is performed by the Bus Matrix, i.e., the implementation of the Advanced High performance Bus (AHB) for its Master and Slave interfaces with additional features.

Decoding breaks up the 4 Gbytes of address space into 16 areas of 256 Mbytes. The areas 1 to 8 are directed to the EBI that associates these areas to the external chip selects NCS0 to NCS7. The area 0 is reserved for the addressing of the internal memories, and a second level of decoding provides 1 Mbyte of internal memory area. The area 15 is reserved for the peripherals and provides access to the Advanced Peripheral Bus (APB).

Other areas are unused and performing an access within them provides an abort to the master requesting such an access.

The Bus Matrix manages five Masters and five Slaves.

Each Master has its own bus and its own decoder, thus allowing a different memory mapping per Master.

Regarding Master 0 and Master 1 (ARM926 Instruction and Data), three different Slaves are assigned to the memory space decoded at address 0x0: one for internal boot, one for external boot, one after remap. Refer to [Table 7-3](#) for details.

Table 7-1. List of Bus Matrix Masters

| | |
|----------|--------------------|
| Master 0 | ARM926 Instruction |
| Master 1 | ARM926 Data |
| Master 2 | PDC |
| Master 3 | LCD Controller |
| Master 4 | USB Host |

Each Slave has its own arbiter, thus allowing a different arbitration per Slave.

Table 7-2. List of Bus Matrix Slaves

| | |
|---------|---|
| Slave 0 | Internal SRAM |
| Slave 1 | Internal ROM |
| Slave 2 | LCD Controller and USB Host Port Interfaces |
| Slave 3 | External Bus Interface |
| Slave 4 | Internal Peripherals |

7.1 Embedded Memories

- 32 KB ROM
 - Single Cycle Access at full bus speed
- 160 KB Fast SRAM
 - Single Cycle Access at full bus speed
 - Supports ARM926EJ-S TCM interface at full processor speed

7.1.1 Internal Memory Mapping

[Table 7-3](#) summarizes the Internal Memory Mapping for each Master, depending on the Remap status and the BMS state at reset.

Table 7-3. Internal Memory Mapping

| Address | Master 0: ARM926 Instruction | | | Master 1: ARM926 Data | | |
|-------------|------------------------------|-------------------------|------------------|-----------------------|-------------------------|------------------|
| | REMAP (RCB0) = 0 | | REMAP (RCB0) = 1 | REMAP (RCB1) = 0 | | REMAP (RCB1) = 1 |
| | BMS = 1 | BMS = 0 | | BMS = 1 | BMS = 0 | |
| 0x0000 0000 | Internal ROM | EBI NCS0 ⁽¹⁾ | Internal RAM C | Internal ROM | EBI NCS0 ⁽¹⁾ | Internal RAM C |

Note: 1. EBI NCS0 is to be connected to a 16-bit non-volatile memory. The access configuration is defined by the reset state of SMC Setup, SMC Pulse, SMC Cycle and SMC Mode CS0 registers.

7.1.1.1 Internal SRAM

The SAM9261 embeds a high-speed 160 Kbyte SRAM. This Internal SRAM is split into three areas. Its Memory Mapping is detailed in [Table 7-3](#) above.

- Internal SRAM A is the ARM926EJ-S Instruction TCM and the user can map this SRAM block anywhere in the ARM926 instruction memory space using CP15 instructions. This SRAM block is also accessible by the ARM926 Data Master and by the AHB Masters through the AHB bus at address 0x0010 0000.
- Internal SRAM B is the ARM926EJ-S Data TCM and the user can map this SRAM block anywhere in the ARM926 data memory space using CP15 instructions. This SRAM block is also accessible by the ARM926 Data Master and by the AHB Masters through the AHB bus at address 0x0020 0000.
- Internal SRAM C is only accessible by all the AHB Masters.
After reset and until the Remap Command is performed, this SRAM block is accessible through the AHB bus at address 0x0030 0000 by all the AHB Masters.
After Remap, this SRAM block also becomes accessible through the AHB bus at address 0x0 by the ARM926 Instruction and the ARM926 Data Masters.

Within the 160 Kbyte SRAM size available, the amount of memory assigned to each block is software programmable as a multiple of 16 Kbytes according to [Table 7-4](#). This table provides the size of the Internal SRAM C according to the size of the Internal SRAM A and the Internal SRAM B.

Table 7-4. Internal SRAM Block Size

| Internal SRAM C | | Internal SRAM A (ITCM) | | | |
|------------------------|-----------|------------------------|------------|------------|-----------|
| | | 0 | 16 Kbytes | 32 Kbytes | 64 Kbytes |
| Internal SRAM B (DCTM) | 0 | 160 Kbytes | 144 Kbytes | 128 Kbytes | 96 Kbytes |
| | 16 Kbytes | 144 Kbytes | 128 Kbytes | 112 Kbytes | 80 Kbytes |
| | 32 Kbytes | 128 Kbytes | 112 Kbytes | 96 Kbytes | 64 Kbytes |
| | 64 Kbytes | 96 Kbytes | 80 Kbytes | 64 Kbytes | 32 Kbytes |

Note that among the ten 16 Kbyte blocks making up the Internal SRAM, two are permanently assigned to Internal SRAM C.

At reset, the whole memory (160 Kbytes) is assigned to Internal SRAM C.

The memory blocks assigned to SRAM A, SRAM B and SRAM C areas are not contiguous and when the user dynamically changes the Internal SRAM configuration, the new 16 Kbyte block organization may affect the previous configuration from a software point of view.

[Table 7-5](#) illustrates different configurations and the related 16 Kbyte blocks (RB0 to RB9) assignments.

Table 7-5. 16 Kbyte Block Allocation

| Decoded Area | Address | Configuration Examples and Related 16 Kbyte Block Assignments | | | |
|------------------------|-------------|---|---|---|--|
| | | ITCM = 0 Kbyte DTCM = 0 Kbyte AHB = 160 Kbytes ⁽¹⁾ | ITCM = 64 Kbytes DTCM = 64 Kbytes AHB = 32 Kbytes | ITCM = 32 Kbytes DTCM = 64 Kbytes AHB = 64 Kbytes | ITCM = 32 Kbytes DTCM = 16 Kbytes AHB = 112 Kbytes |
| Internal SRAM A (ITCM) | 0x0010 0000 | – | RB3 | RB3 | RB3 |
| | 0x0010 4000 | – | RB2 | RB2 | RB2 |
| | 0x0010 8000 | – | RB1 | – | – |
| | 0x0010 C000 | – | RB0 | – | – |
| Internal SRAM B (DTCM) | 0x0020 0000 | – | RB7 | RB7 | RB7 |
| | 0x0020 4000 | – | RB6 | RB6 | – |
| | 0x0020 8000 | – | RB5 | RB5 | – |
| | 0x0020 C000 | – | RB4 | RB4 | – |
| Internal SRAM C (AHB) | 0x0030 0000 | RB9 | RB9 | RB9 | RB9 |
| | 0x0030 4000 | RB8 | RB8 | RB8 | RB8 |
| | 0x0030 8000 | RB7 | – | RB1 | RB6 |
| | 0x0030 C000 | RB6 | – | RB0 | RB5 |
| | 0x0031 0000 | RB5 | – | – | RB4 |
| | 0x0031 4000 | RB4 | – | – | RB1 |
| | 0x0031 8000 | RB3 | – | – | RB0 |
| | 0x0031 C000 | RB2 | – | – | – |
| | 0x0032 0000 | RB1 | – | – | – |
| | 0x0032 4000 | RB0 | – | – | – |

Note: 1. Configuration after reset.

7.1.1.2 Internal ROM

The SAM9261 integrates a 32 Kbyte Internal ROM mapped at address 0x0040 0000. It is also accessible at address 0x0 after reset and before remap if the BMS is tied high during reset.

7.1.1.3 USB Host Port

The SAM9261 integrates a USB Host Port Open Host Controller Interface (OHCI). The registers of this interface are directly accessible on the AHB Bus and are mapped like a standard internal memory at address 0x0050 0000.

7.1.1.4 LCD Controller

The SAM9261 integrates an LCD Controller. The interface is directly accessible on the AHB Bus and is mapped like a standard internal memory at address 0x0060 0000.

7.1.2 Boot Strategies

The system always boots at address 0x0. To ensure a maximum number of possibilities for boot, the memory layout can be configured with two parameters.

REMAP allows the user to lay out the first internal SRAM bank to 0x0 to ease development. This is done by software once the system has booted for each Master of the Bus Matrix. Refer to [Section 18. “Bus Matrix”](#) for more details.

When REMAP = 0, BMS allows the user to lay out to 0x0, at his convenience, the ROM or an external memory. This is done via hardware at reset.

Note: Memory blocks not affected by these parameters can always be seen at their specified base addresses. See the complete memory map presented in [Figure 7-1 on page 17](#).

The SAM9261 Bus Matrix manages a boot memory that depends on the level on the BMS pin at reset. The internal memory area mapped between address 0x0 and 0x000F FFFF is reserved for this purpose.

If BMS is detected at 1, the boot memory is the embedded ROM.

If BMS is detected at 0, the boot memory is the memory connected on the Chip Select 0 of the External Bus Interface.

7.1.2.1 BMS = 1, Boot on Embedded ROM

The system boots using the Boot Program.

- Enable the 32.768 kHz oscillator
- Auto baud rate detection
- Downloads and runs an application from external storage media into internal SRAM
- Automatic detection of valid application
- Bootloader on a non-volatile memory
 - SPI Serial Flash or DataFlash connected on NPCS0 of SPI0
 - NAND Flash
 - SDCard (boot ROM does not support high-capacity SDCards)
- SAM-BA[®] boot in case no valid program is detected in external NVM, supporting:
 - Serial Communication on a DBGU
 - USB Device HS Port

7.1.2.2 BMS = 0, Boot on External Memory

- Boot on slow clock (32.768 kHz)
- Boot with the default configuration for the Static Memory Controller, byte select mode, 16-bit data bus, Read/Write controlled by Chip Select, allows boot on 16-bit non-volatile memory.

The customer-programmed software must perform a complete configuration.

To speed up the boot sequence when booting at 32 kHz EBI CS0 (BMS = 0), the user must take the following steps:

1. Program the PMC (main oscillator enable or bypass mode).
2. Program and start the PLL.
3. Reprogram the SMC setup, cycle, hold, mode timings registers for CS0 to adapt them to the new clock
4. Switch the main clock to the new value.

7.1.3 ETM Memories

The eight ETM9 Medium+ memory map decoder inputs are connected to custom address decoders and the resulting memory mapping is summarized in [Table 7-6 on page 22](#).

Table 7-6. ETM9 Memory Mapping

| Product Resource | Area | Access Type | Start Address | End Address |
|------------------------|----------|-------------|---------------|-------------|
| SRAM | Internal | Data | 0x0000 0000 | 0x002F FFFF |
| SRAM | Internal | Fetch | 0x0000 0000 | 0x002F FFFF |
| ROM | Internal | Data | 0x0040 0000 | 0x004F FFFF |
| ROM | Internal | Fetch | 0x0040 0000 | 0x004F FFFF |
| External Bus Interface | External | Data | 0x1000 0000 | 0x8FFF FFFF |
| External Bus Interface | External | Fetch | 0x1000 0000 | 0x8FFF FFFF |
| User Peripherals | Internal | Data | 0xF000 0000 | 0xFFFF BFFF |
| System Peripherals | Internal | Data | 0xFFFF C000 | 0xFFFF FFFF |

7.2 External Memories

The external memories are accessed through the External Bus Interface (Bus Matrix Slave 3).

Refer to the memory map in [Figure 7-1 on page 17](#).

8. System Controller

The System Controller manages all vital blocks of the microcontroller: interrupts, clocks, power, time, debug and reset.

The System Peripherals are all mapped within the highest 6 Kbytes of address space, between addresses 0xFFFF EA00 and 0xFFFF FFFF. Each peripheral has an address space of 256 or 512 bytes, representing 64 or 128 registers.

[Figure 8-1 on page 24](#) shows the System Controller block diagram.

[Figure 7-1 on page 17](#) shows the mapping of the User Interfaces of the System Controller peripherals.

8.1 Block Diagram

Figure 8-1. System Controller Block Diagram

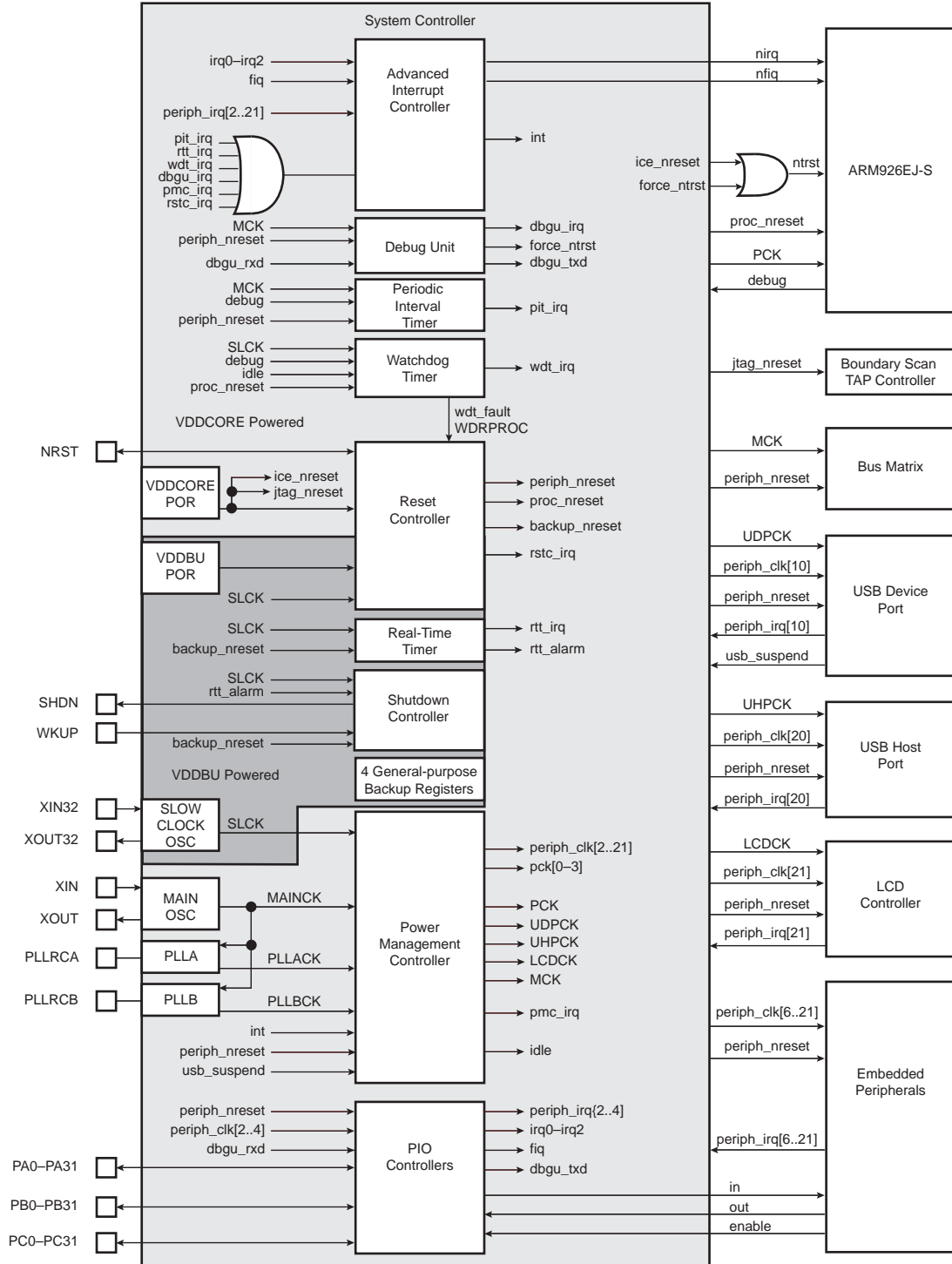

8.2 Reset Controller

See [Section 13.2 “Embedded Characteristics”](#).

8.3 Shutdown Controller

See [Section 16.2 “Embedded Characteristics”](#).

8.4 General-purpose Backup Registers

- Four 32-bit general-purpose backup registers

8.5 Clock Generator

- Embeds the Low-power 32.768 kHz Slow Clock Oscillator
 - Provides the permanent Slow Clock to the system
- Embeds the Main Oscillator
 - Oscillator bypass feature
 - Supports 3 to 20 MHz crystals
- Embeds Two PLLs
 - Outputs 80 to 240 MHz clocks
 - Integrates an input divider to increase output accuracy
 - 1 MHz minimum input frequency
- Provides SLCK, MAINCK, PLLACK and PLLBCK.

Figure 8-2. Clock Generator Block Diagram

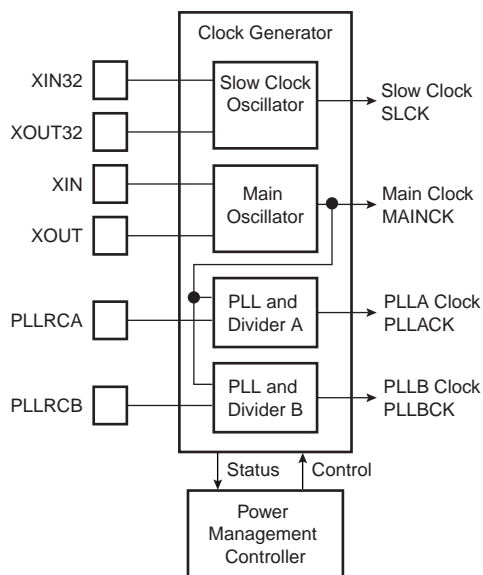

8.6 Power Management Controller

- The Power Management Controller provides:
 - the Processor Clock PCK
 - the Master Clock MCK
 - the USB Clock USBCK (HCK0)
 - the LCD Controller Clock LCDCK (HCK1)
 - up to thirty peripheral clocks
 - four programmable clock outputs: PCK0 to PCK3

Figure 8-3. Power Management Controller Block Diagram

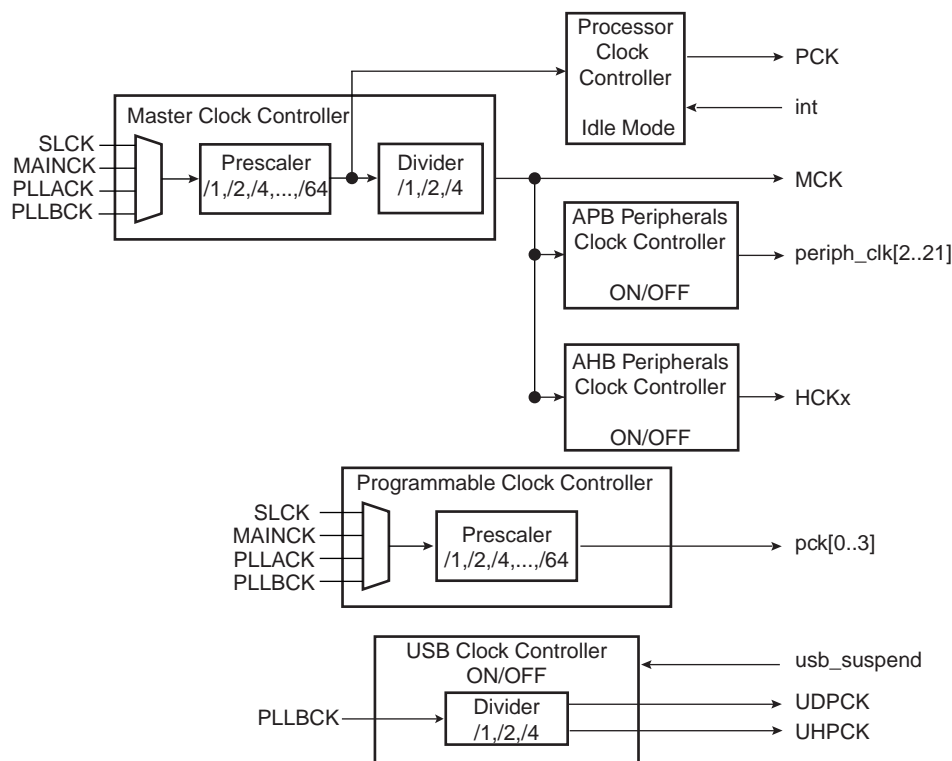

8.7 Periodic Interval Timer

See [Section 15.2 “Embedded Characteristics”](#).

8.8 Watchdog Timer

See [Section 25.2 “Embedded Characteristics”](#).

8.9 Real-time Timer

See [Section 14.2 “Embedded Characteristics”](#).

8.10 Advanced Interrupt Controller

- Controls the interrupt lines (nIRQ and nFIQ) of an ARM Processor
- Thirty-two individually maskable and vectored interrupt sources
 - Source 0 is reserved for the Fast Interrupt Input (FIQ)
 - Source 1 is reserved for system peripherals (PIT, RTT, PMC, DBGU, etc.)
 - Source 2 to Source 31 control up to thirty embedded peripheral interrupts or external interrupts
 - Programmable edge-triggered or level-sensitive internal sources
 - Programmable positive/negative edge-triggered or high/low level-sensitive
- Four External Sources
- 8-level Priority Controller
 - Drives the normal interrupt of the processor
 - Handles priority of the interrupt sources 1 to 31
 - Higher priority interrupts can be served during service of lower priority interrupt
- Vectoring
 - Optimizes Interrupt Service Routine Branch and Execution
 - One 32-bit Vector Register per interrupt source
 - Interrupt Vector Register reads the corresponding current Interrupt Vector
- Protect Mode
 - Easy debugging by preventing automatic operations when protect mode is enabled
- Fast Forcing
 - Permits redirecting any normal interrupt source on the Fast Interrupt of the processor
- General Interrupt Mask
 - Provides processor synchronization on events without triggering an interrupt

8.11 Debug Unit

See [Section 27.2 “Embedded Characteristics”](#).

8.12 PIO Controllers

- Three PIO Controllers, each controlling up to 32 programmable I/O Lines
 - PIOA has 32 I/O Lines
 - PIOB has 32 I/O Lines
 - PIOC has 32 I/O Lines
- Fully programmable through Set/Clear Registers
- Multiplexing of two peripheral functions per I/O Line
- For each I/O Line (whether assigned to a peripheral or used as general-purpose I/O)
 - Input change interrupt
 - Glitch filter
 - Multi-drive option enables driving in open drain
 - Programmable pull up on each I/O line
 - Pin data status register, supplies visibility of the level on the pin at any time
- Synchronous output, provides Set and Clear of several I/O lines in a single write

9. Peripherals

9.1 User Interface

The User Peripherals are mapped in the upper 256 Mbytes of the address space between the addresses 0xFFFFA 0000 and 0xFFFFC FFFF. Each User Peripheral is allocated 16 Kbytes of address space.

A complete memory map is presented in [Figure 7-1 on page 17](#).

9.2 Peripheral Identifiers

[Table 9-1](#) defines the Peripheral Identifiers of the SAM9261. A peripheral identifier is required for the control of the peripheral interrupt with the Advanced Interrupt Controller and for the control of the peripheral clock with the Power Management Controller.

Table 9-1. Peripheral Identifiers

| Peripheral ID | Peripheral Mnemonic | Peripheral Name | External Interrupt |
|---------------|---------------------|---------------------------------|--------------------|
| 0 | AIC | Advanced Interrupt Controller | FIQ |
| 1 | SYSC | System Controller Interrupt | – |
| 2 | PIOA | Parallel I/O Controller A | – |
| 3 | PIOB | Parallel I/O Controller B | – |
| 4 | PIOC | Parallel I/O Controller C | – |
| 5 | – | Reserved | – |
| 6 | US0 | USART 0 | – |
| 7 | US1 | USART 1 | – |
| 8 | US2 | USART 2 | – |
| 9 | MCI | Multimedia Card Interface | – |
| 10 | UDP | USB Device Port | – |
| 11 | TWI | Two-Wire Interface | – |
| 12 | SPI0 | Serial Peripheral Interface 0 | – |
| 13 | SPI1 | Serial Peripheral Interface 1 | – |
| 14 | SSC0 | Synchronous Serial Controller 0 | – |
| 15 | SSC1 | Synchronous Serial Controller 1 | – |
| 16 | SSC2 | Synchronous Serial Controller 2 | – |
| 17 | TC0 | Timer/Counter 0 | – |
| 18 | TC1 | Timer/Counter 1 | – |
| 19 | TC2 | Timer/Counter 2 | – |
| 20 | UHP | USB Host Port | – |
| 21 | LCDC | LCD Controller | – |
| 22–28 | – | Reserved | – |
| 29 | AIC | Advanced Interrupt Controller | IRQ0 |
| 30 | AIC | Advanced Interrupt Controller | IRQ1 |
| 31 | AIC | Advanced Interrupt Controller | IRQ2 |

Note: Setting AIC, SYSC, UHP, LCDC and IRQ0 to IRQ2 bits in the clock set/clear registers of the PMC has no effect.

9.3 Peripheral Multiplexing on PIO Lines

The SAM9261 features three PIO controllers, PIOA, PIOB and PIOC, that multiplex the I/O lines of the peripheral set.

Each PIO Controller controls up to thirty-two lines. Each line can be assigned to one of two peripheral functions, A or B. The tables in [Section 9.3.2 “PIO Controller Multiplexing Tables”](#) define how the I/O lines of the peripherals A and B are multiplexed on the PIO Controllers. The tables include the columns “Function” and “Comments” which can be used by the user to track how pins are defined in an application.

Note that some output only peripheral functions might be duplicated within the tables.

The column “Reset State” indicates whether the PIO line resets in I/O mode or in peripheral mode. If I/O is mentioned, the PIO line resets in input with the pull-up enabled, so that the device is maintained in a static state as soon as the reset is released. As a result, the bit corresponding to the PIO line in the Peripheral Status Register (PIO_PSR) resets low.

If a signal name is mentioned in the “Reset State” column, the PIO line is assigned to this function and the corresponding bit in PIO_PSR resets high. This is the case of pins controlling memories, in particular the address lines, which require the pin to be driven as soon as the reset is released. Note that the pull-up resistor is also enabled in this case.

9.3.1 Resource Multiplexing

9.3.1.1 LCD Controller

The LCD Controller can interface with several LCD panels. It supports 4, 8 or 16 bit-per-pixel without any limitation. Interfacing 24 bit-per-pixel TFTs panel prevents using the SSC0 and the chip select line 0 of the SPI1.

16 bit-per-pixel TFT panels are interfaced through peripheral B functions, as color data is output on LCDD3 to LCDD7, LCDD11 to LCDD15 and LCDD19 to LCDD23. Intensity bit is output on LCDD2, LCDD10 and LCDD18. Using the peripheral B does not prevent using the SSC0 and the SPI1 lines.

9.3.1.2 ETM

Using the ETM prevents:

- using the USART1 and USART2 control signals, in particular the SCK lines which are required to use the USART as ISO7816 and the RTS and CTS to handle hardware handshaking on the serial lines. In case the ETM and an ISO7816 connection are both required, the USART0 has to be used as a Smart Card interface.
- using the SSC1
- addressing a static memory of more than 8 Mbytes, which requires the A23 and A24 address lines
- using the chip select lines 1 to 3 of SPI0 and SPI1

9.3.1.3 EBI

If not required, the NWAIT function (external wait request) can be deactivated by software, allowing this pin to be used as a PIO.

9.3.1.4 32-bit Data Bus

Using a 32-bit Data Bus prevents:

- using the three Timer Counter channels' outputs and trigger inputs
- using the SSC2

9.3.1.5 NAND Flash Interface

Using the NAND Flash interface prevents:

- using NCS3, NCS6 and NCS7 to access other parallel devices

9.3.1.6 CompactFlash Interface

Using the CompactFlash interface prevents:

- using NCS4 and/or NCS5 to access other parallel devices

9.3.1.7 SPI0 and the MultiMedia Card Interface

As the DataFlash Card is compatible with the SDCard, it is useful to multiplex SPI and MCI. Here, the SPI0 signal is multiplexed with the MCI.

9.3.1.8 USARTs

- Using the USART1 and USART2 control signals prevents using the ETM.
- Alternatively, using USART0 with its control signals prevents using some clock outputs and interrupt lines.

9.3.1.9 Clock Outputs

- Using the clock outputs multiplexed with the PIO A prevents using the Debug Unit and/or the Two Wire Interface.
- Alternatively, using the second implementation of the clock outputs prevents using the LCD Controller Interface and/or USART0.

9.3.1.10 Interrupt Lines

- Using FIQ prevents using the USART0 control signals.
- Using IRQ0 prevents using the NWAIT EBI signal.
- Using the IRQ1 and/or IRQ2 prevents using the SPI1.

9.3.2 PIO Controller Multiplexing Tables

Table 9-2. Multiplexing on PIO Controller A

| PIO Controller A | | | | | Application Usage | | |
|------------------|--------------|--------------|----------|-------------|-------------------|----------|----------|
| I/O Line | Peripheral A | Peripheral B | Comments | Reset State | Power Supply | Function | Comments |
| PA0 | SPI0_MISO | MCDA0 | | I/O | VDDIOP | | |
| PA1 | SPI0_MOSI | MCCDA | | I/O | VDDIOP | | |
| PA2 | SPI0_SPCK | MCCK | | I/O | VDDIOP | | |
| PA3 | SPI0_NPCS0 | – | | I/O | VDDIOP | | |
| PA4 | SPI0_NPCS1 | MCDA1 | | I/O | VDDIOP | | |
| PA5 | SPI0_NPCS2 | MCDA2 | | I/O | VDDIOP | | |
| PA6 | SPI0_NPCS3 | MCDA3 | | I/O | VDDIOP | | |
| PA7 | TWD | PCK0 | | I/O | VDDIOP | | |
| PA8 | TWCK | PCK1 | | I/O | VDDIOP | | |
| PA9 | DRXD | PCK2 | | I/O | VDDIOP | | |
| PA10 | DTXD | PCK3 | | I/O | VDDIOP | | |
| PA11 | TSYNC | SCK1 | | I/O | VDDIOP | | |
| PA12 | TCLK | RTS1 | | I/O | VDDIOP | | |
| PA13 | TPS0 | CTS1 | | I/O | VDDIOP | | |
| PA14 | TPS1 | SCK2 | | I/O | VDDIOP | | |
| PA15 | TPS2 | RTS2 | | I/O | VDDIOP | | |
| PA16 | TPK0 | CTS2 | | I/O | VDDIOP | | |
| PA17 | TPK1 | TF1 | | I/O | VDDIOP | | |
| PA18 | TPK2 | TK1 | | I/O | VDDIOP | | |
| PA19 | TPK3 | TD1 | | I/O | VDDIOP | | |
| PA20 | TPK4 | RD1 | | I/O | VDDIOP | | |
| PA21 | TPK5 | RK1 | | I/O | VDDIOP | | |
| PA22 | TPK6 | RF1 | | I/O | VDDIOP | | |
| PA23 | TPK7 | RTS0 | | I/O | VDDIOP | | |
| PA24 | TPK8 | SPI1_NPCS1 | | I/O | VDDIOP | | |
| PA25 | TPK9 | SPI1_NPCS2 | | I/O | VDDIOP | | |
| PA26 | TPK10 | SPI1_NPCS3 | | I/O | VDDIOP | | |
| PA27 | TPK11 | SPI0_NPCS1 | | I/O | VDDIOP | | |
| PA28 | TPK12 | SPI0_NPCS2 | | I/O | VDDIOP | | |
| PA29 | TPK13 | SPI0_NPCS3 | | I/O | VDDIOP | | |
| PA30 | TPK14 | A23 | | A23 | VDDIOP | | |
| PA31 | TPK15 | A24 | | A24 | VDDIOP | | |

Table 9-3. Multiplexing on PIO Controller B

| PIO Controller B | | | | | Application Usage | | |
|--------------------|--------------|--------------|----------|-------------|-------------------|----------|----------|
| I/O Line | Peripheral A | Peripheral B | Comments | Reset State | Power Supply | Function | Comments |
| PB0 | LCDVSYNC | – | | I/O | VDDIOP | | |
| PB1 | LCDHSYNC | – | | I/O | VDDIOP | | |
| PB2 | LCDDOTCK | PCK0 | | I/O | VDDIOP | | |
| PB3 ⁽¹⁾ | LCDDEN | – | | I/O | VDDIOP | | |
| PB4 | LCDD0 | LCDD2 | | I/O | VDDIOP | | |
| PB5 | LCDD0 | LCDD3 | | I/O | VDDIOP | | |
| PB6 | LCDD1 | LCDD4 | | I/O | VDDIOP | | |
| PB7 | LCDD2 | LCDD5 | | I/O | VDDIOP | | |
| PB8 | LCDD3 | LCDD6 | | I/O | VDDIOP | | |
| PB9 | LCDD4 | LCDD7 | | I/O | VDDIOP | | |
| PB10 | LCDD5 | LCDD10 | | I/O | VDDIOP | | |
| PB11 | LCDD6 | LCDD11 | | I/O | VDDIOP | | |
| PB12 | LCDD7 | LCDD12 | | I/O | VDDIOP | | |
| PB13 | LCDD8 | LCDD13 | | I/O | VDDIOP | | |
| PB14 | LCDD9 | LCDD14 | | I/O | VDDIOP | | |
| PB15 | LCDD10 | LCDD15 | | I/O | VDDIOP | | |
| PB16 | LCDD11 | LCDD19 | | I/O | VDDIOP | | |
| PB17 | LCDD12 | LCDD20 | | I/O | VDDIOP | | |
| PB18 | LCDD13 | LCDD21 | | I/O | VDDIOP | | |
| PB19 | LCDD14 | LCDD22 | | I/O | VDDIOP | | |
| PB20 | LCDD15 | LCDD23 | | I/O | VDDIOP | | |
| PB21 | TF0 | LCDD16 | | I/O | VDDIOP | | |
| PB22 | TK0 | LCDD17 | | I/O | VDDIOP | | |
| PB23 | TD0 | LCDD18 | | I/O | VDDIOP | | |
| PB24 | RD0 | LCDD19 | | I/O | VDDIOP | | |
| PB25 | RK0 | LCDD20 | | I/O | VDDIOP | | |
| PB26 | RF0 | LCDD21 | | I/O | VDDIOP | | |
| PB27 | SPI1_NPCS1 | LCDD22 | | I/O | VDDIOP | | |
| PB28 | SPI1_NPCS0 | LCDD23 | | I/O | VDDIOP | | |
| PB29 | SPI1_SPCK | IRQ2 | | I/O | VDDIOP | | |
| PB30 | SPI1_MISO | IRQ1 | | I/O | VDDIOP | | |
| PB31 | SPI1_MOSI | PCK2 | | I/O | VDDIOP | | |

Note: 1. PB3 is multiplexed with BMS signal. Care should be taken during reset time.

Table 9-4. Multiplexing on PIO Controller C

| PIO Controller C | | | | | Application Usage | | |
|------------------|--------------|--------------|----------|-------------|-------------------|----------|----------|
| I/O Line | Peripheral A | Peripheral B | Comments | Reset State | Power Supply | Function | Comments |
| PC0 | NANDOE | NCS6 | | I/O | VDDIOP | | |
| PC1 | NANDWE | NCS7 | | I/O | VDDIOP | | |
| PC2 | NWAIT | IRQ0 | | I/O | VDDIOP | | |
| PC3 | A25/CFRNW | – | | A25 | VDDIOP | | |
| PC4 | NCS4/CFCS0 | – | | I/O | VDDIOP | | |
| PC5 | NCS5/CFCS1 | – | | I/O | VDDIOP | | |
| PC6 | CFCE1 | – | | I/O | VDDIOP | | |
| PC7 | CFCE2 | – | | I/O | VDDIOP | | |
| PC8 | TXD0 | PCK2 | | I/O | VDDIOP | | |
| PC9 | RXD0 | PCK3 | | I/O | VDDIOP | | |
| PC10 | RTS0 | SCK0 | | I/O | VDDIOP | | |
| PC11 | CTS0 | FIQ | | I/O | VDDIOP | | |
| PC12 | TXD1 | NCS6 | | I/O | VDDIOP | | |
| PC13 | RXD1 | NCS7 | | I/O | VDDIOP | | |
| PC14 | TXD2 | SPI1_NPCS2 | | I/O | VDDIOP | | |
| PC15 | RXD2 | SPI1_NPCS3 | | I/O | VDDIOP | | |
| PC16 | D16 | TCLK0 | | I/O | VDDIOM | | |
| PC17 | D17 | TCLK1 | | I/O | VDDIOM | | |
| PC18 | D18 | TCLK2 | | I/O | VDDIOM | | |
| PC19 | D19 | TIOA0 | | I/O | VDDIOM | | |
| PC20 | D20 | TIOB0 | | I/O | VDDIOM | | |
| PC21 | D21 | TIOA1 | | I/O | VDDIOM | | |
| PC22 | D22 | TIOB1 | | I/O | VDDIOM | | |
| PC23 | D23 | TIOA2 | | I/O | VDDIOM | | |
| PC24 | D24 | TIOB2 | | I/O | VDDIOM | | |
| PC25 | D25 | TF2 | | I/O | VDDIOM | | |
| PC26 | D26 | TK2 | | I/O | VDDIOM | | |
| PC27 | D27 | TD2 | | I/O | VDDIOM | | |
| PC28 | D28 | RD2 | | I/O | VDDIOM | | |
| PC29 | D29 | RK2 | | I/O | VDDIOM | | |
| PC30 | D30 | RF2 | | I/O | VDDIOM | | |
| PC31 | D31 | PCK1 | | I/O | VDDIOM | | |

9.3.3 System Interrupt

The System Interrupt in Source 1 is the wired-OR of the interrupt signals coming from:

- the SDRAM Controller
- the Debug Unit
- the Periodic Interval Timer
- the Real-Time Timer
- the Watchdog Timer
- the Reset Controller
- the Power Management Controller

The clock of these peripherals cannot be deactivated and Peripheral ID 1 can only be used within the Advanced Interrupt Controller.

9.3.4 External Interrupts

All external interrupt signals, i.e., the Fast Interrupt signal FIQ or the Interrupt signals IRQ0 to IRQ2, use a dedicated Peripheral ID. However, there is no clock control associated with these peripheral IDs.

9.4 External Bus Interface

- Integrates two External Memory Controllers:
 - Static Memory Controller
 - SDRAM Controller
- Additional logic for NAND Flash and CompactFlash support
 - NAND Flash support: 8-bit as well as 16-bit devices are supported
 - CompactFlash support: all modes (Attribute Memory, Common Memory, I/O, True IDE) are supported but the signals -IOIS16 (I/O and True IDE modes) and -ATA SEL (True IDE mode) are not handled.
- Optimized External Bus
 - 16 or 32-bit Data Bus
 - Up to 26-bit Address Bus, up to 64 Mbytes addressable
 - Eight Chip Selects, each reserved to one of the eight Memory Areas
 - Optimized pin multiplexing to reduce latencies on External Memories
- Configurable Chip Select Assignment Managed by EBI_CSA Register located in the MATRIX user interface
 - Static Memory Controller on NCS0
 - SDRAM Controller or Static Memory Controller on NCS1
 - Static Memory Controller on NCS2
 - Static Memory Controller on NCS3, Optional NAND Flash Support
 - Static Memory Controller on NCS4–NCS5, Optional CompactFlash Support
 - Static Memory Controller on NCS6–NCS7

9.5 Static Memory Controller

- External memory mapping, 256 Mbyte address space per Chip Select Line
- Up to Eight Chip Select Lines
- 8, 16 or 32-bit Data Bus
- Multiple Access Modes supported
 - Byte Write or Byte Select Lines
 - Asynchronous read in Page Mode supported (4-byte up to 32-byte page size)
- Multiple device adaptability
 - Compliant with LCD Module
 - Control signal programmable setup, pulse and hold time for each Memory Bank
- Multiple Wait State Management
 - Programmable Wait State Generation
 - External Wait Request
 - Programmable Data Float Time
- Slow Clock Mode Supported

9.6 SDRAM Controller

- Supported Devices
 - Standard and Low Power SDRAM (Mobile SDRAM)
- Numerous configurations supported
 - 2K, 4K, 8K Row Address Memory Parts
 - SDRAM with two or four Internal Banks
 - SDRAM with 16 or 32-bit Data Path
- Programming Facilities
 - Word, half-word, byte access
 - Automatic page break when Memory Boundary has been reached
 - Multibank Ping-pong Access
 - Timing parameters specified by software
 - Automatic refresh operation, refresh rate is programmable
- Energy-saving Capabilities
 - Self-refresh, power down and deep power down modes supported
- Error detection
 - Refresh Error Interrupt
- SDRAM Powerup Initialization by software
- CAS Latency of 1, 2 and 3 supported
- Auto Precharge Command not used

9.7 Serial Peripheral Interface

- Supports communication with serial external devices
 - Four chip selects with external decoder support allow communication with up to fifteen peripherals
 - Serial memories, such as DataFlash and 3-wire EEPROMs
 - Serial peripherals, such as ADCs, DACs, LCD Controllers, CAN Controllers and Sensors
 - External co-processors
- Master or slave serial peripheral bus interface
 - 8 to 16-bit programmable data length per chip select
 - Programmable phase and polarity per chip select
 - Programmable transfer delays between consecutive transfers and between clock and data per chip select
 - Programmable delay between consecutive transfers
 - Selectable mode fault detection
- Very fast transfers supported
 - Transfers with baud rates up to MCK
 - The chip select line may be left active to speed up transfers on the same device

9.8 Two-wire Interface

See [Section 30.2 “Embedded Characteristics”](#).

9.9 USART

- Programmable Baud Rate Generator
- 5 to 9-bit full-duplex synchronous or asynchronous serial communications
 - 1, 1.5 or 2 stop bits in Asynchronous Mode or 1 or 2 stop bits in Synchronous Mode
 - Parity generation and error detection
 - Framing error detection, overrun error detection
 - MSB- or LSB-first
 - Optional break generation and detection
 - By-8 or by-16 over-sampling receiver frequency
 - Hardware handshaking RTS-CTS
 - Receiver time-out and transmitter timeguard
 - Optional Multi-drop Mode with address generation and detection
- RS485 with driver control signal
- ISO7816, T = 0 or T = 1 Protocols for interfacing with smart cards
 - NACK handling, error counter with repetition and iteration limit
- IrDA modulation and demodulation
 - Communication at up to 115.2 Kbps
- Test Modes
 - Remote Loopback, Local Loopback, Automatic Echo

9.10 Synchronous Serial Controller

- Provides serial synchronous communication links used in audio and telecom applications (with CODECs in Master or Slave Modes, I²S, TDM Buses, Magnetic Card Reader and more).
- Contains an independent receiver and transmitter and a common clock divider.
- Offers a configurable frame sync and data length.
- Receiver and transmitter can be programmed to start automatically or on detection of different event on the frame sync signal.
- Receiver and transmitter include a data signal, a clock signal and a frame synchronization signal.

9.11 Timer Counter

See [Section 33.2 “Embedded Characteristics”](#).

9.12 Multimedia Card Interface

See [Section 34.2 “Embedded Characteristics”](#).

9.13 USB

- USB Host Port
 - See [Section 35.2 “Embedded Characteristics”](#).
- USB Device Port
 - Six general-purpose endpoints:
 - Endpoint 0: 8 bytes, no ping-pong mode
 - Endpoint 1, Endpoint 2: 64 bytes, ping-pong mode
 - Endpoint 3: 64 bytes, no ping-pong mode
 - Endpoint 4, Endpoint 5: 256 bytes, ping-pong mode
 - See [Section 36.2 “Embedded Characteristics”](#).
- Embedded pad pull-up configurable via USB_PUCR located in the MATRIX user interface

9.14 LCD Controller

- Single and Dual scan color and monochrome passive STN LCD panels supported
- Single scan active TFT LCD panels supported.
- 4-bit single scan, 8-bit single or dual scan, 16-bit dual scan STN interfaces supported
- Up to 24-bit single scan TFT interfaces supported
- Up to 16 gray levels for mono STN and up to 4096 colors for color STN displays
- 1, 2 bits per pixel (palletized), 4 bits per pixel (non-palletized) for mono STN
- 1, 2, 4, 8 bits per pixel (palletized), 16 bits per pixel (non-palletized) for color STN
- 1, 2, 4, 8 bits per pixel (palletized), 16, 24 bits per pixel (non-palletized) for TFT
- Single clock domain architecture
- Resolution supported up to 2048 x 2048

10. ARM926EJ-S Processor

10.1 Overview

The ARM926EJ-S processor is a member of the ARM9™ family of general-purpose microprocessors. The ARM926EJ-S implements ARM architecture version 5TEJ and is targeted at multi-tasking applications where full memory management, high performance, low die size and low power are all important features.

The ARM926EJ-S processor supports the 32-bit ARM and 16-bit Thumb instruction sets, enabling the user to trade off between high performance and high code density. It also supports 8-bit Java instruction set and includes features for efficient execution of Java bytecode, providing a Java performance similar to a JIT (Just-In-Time compilers), for the next generation of Java-powered wireless and embedded devices. It includes an enhanced multiplier design for improved DSP performance.

The ARM926EJ-S processor supports the ARM debug architecture and includes logic to assist in both hardware and software debug.

The ARM926EJ-S provides a complete high performance processor subsystem, including:

- an ARM9EJ-S™ integer core
- a Memory Management Unit (MMU)
- separate instruction and data AMBA® AHB bus interfaces
- separate instruction and data TCM interfaces

10.2 Block Diagram

Figure 10-1. ARM926EJ-S Internal Functional Block Diagram

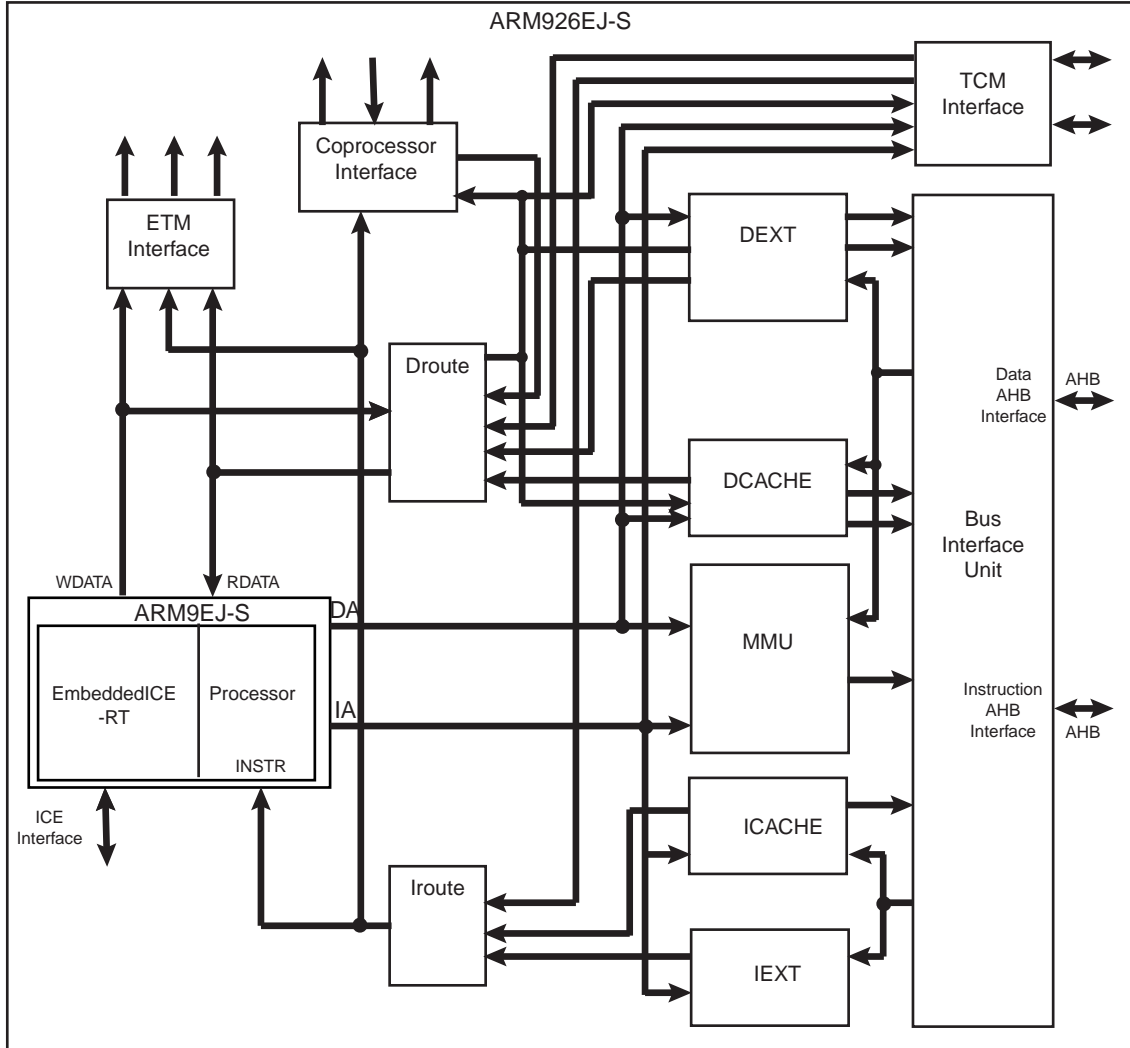

10.3 ARM9EJ-S Processor

10.3.1 ARM9EJ-S Operating States

The ARM9EJ-S processor can operate in three different states, each with a specific instruction set:

- ARM state: 32-bit, word-aligned ARM instructions.
- Thumb state: 16-bit, halfword-aligned Thumb instructions.
- Jazelle state: variable length, byte-aligned Jazelle instructions.

In Jazelle state, all instruction Fetches are in words.

10.3.2 Switching State

The operating state of the ARM9EJ-S core can be switched between:

- ARM state and Thumb state using the BX and BLX instructions, and loads to the PC
- ARM state and Jazelle state using the BXJ instruction

All exceptions are entered, handled and exited in ARM state. If an exception occurs in Thumb or Jazelle states, the processor reverts to ARM state. The transition back to Thumb or Jazelle states occurs automatically on return from the exception handler.

10.3.3 Instruction Pipelines

The ARM9EJ-S core uses two kinds of pipelines to increase the speed of the flow of instructions to the processor.

A five-stage (five clock cycles) pipeline is used for ARM and Thumb states. It consists of Fetch, Decode, Execute, Memory and Writeback stages.

A six-stage (six clock cycles) pipeline is used for Jazelle state. It consists of Fetch, Jazelle/Decode (two clock cycles), Execute, Memory and Writeback stages.

10.3.4 Memory Access

The ARM9EJ-S core supports byte (8-bit), half-word (16-bit) and word (32-bit) access. Words must be aligned to four-byte boundaries, half-words must be aligned to two-byte boundaries and bytes can be placed on any byte boundary.

Because of the nature of the pipelines, it is possible for a value to be required for use before it has been placed in the register bank by the actions of an earlier instruction. The ARM9EJ-S control logic automatically detects these cases and stalls the core or forward data.

10.3.5 Jazelle Technology

The Jazelle technology enables direct and efficient execution of Java byte codes on ARM processors, providing high performance for the next generation of Java-powered wireless and embedded devices.

The new Java feature of ARM9EJ-S can be described as a hardware emulation of a JVM (Java Virtual Machine). Java mode appears as another state: instead of executing ARM or Thumb instructions, it executes Java byte codes. The Java byte code decoder logic implemented in ARM9EJ-S decodes 95% of executed byte codes and turns them into ARM instructions without any overhead, while less frequently used byte codes are broken down into optimized sequences of ARM instructions. The hardware/software split is invisible to the programmer, invisible to the application and invisible to the operating system. All existing ARM registers are re-used in Jazelle state and all registers then have particular functions in this mode.

Minimum interrupt latency is maintained across both ARM state and Java state. Since byte codes execution can be restarted, an interrupt automatically triggers the core to switch from Java state to ARM state for the execution of the interrupt handler. This means that no special provision has to be made for handling interrupts while executing byte codes, whether in hardware or in software.

10.3.6 ARM9EJ-S Operating Modes

In all states, there are seven operation modes:

- User mode is the usual ARM program execution state. It is used for executing most application programs
- Fast Interrupt (FIQ) mode is used for handling fast interrupts. It is suitable for high-speed data transfer or channel process
- Interrupt (IRQ) mode is used for general-purpose interrupt handling
- Supervisor mode is a protected mode for the operating system
- Abort mode is entered after a data or instruction prefetch abort
- System mode is a privileged user mode for the operating system
- Undefined mode is entered when an undefined instruction exception occurs

Mode changes may be made under software control, or may be brought about by external interrupts or exception processing. Most application programs execute in User Mode. The non-user modes, known as privileged modes, are entered in order to service interrupts or exceptions or to access protected resources.

10.3.7 ARM9EJ-S Registers

The ARM9EJ-S core has a total of 37 registers.

- 31 general-purpose 32-bit registers
- Six 32-bit status registers

Table 10-1 shows all the registers in all modes.

Table 10-1. ARM9EJ-S Modes and Registers Layout

| User and System Mode | Supervisor Mode | Abort Mode | Undefined Mode | Interrupt Mode | Fast Interrupt Mode |
|----------------------|-----------------|------------|----------------|----------------|---------------------|
| R0 | R0 | R0 | R0 | R0 | R0 |
| R1 | R1 | R1 | R1 | R1 | R1 |
| R2 | R2 | R2 | R2 | R2 | R2 |
| R3 | R3 | R3 | R3 | R3 | R3 |
| R4 | R4 | R4 | R4 | R4 | R4 |
| R5 | R5 | R5 | R5 | R5 | R5 |
| R6 | R6 | R6 | R6 | R6 | R6 |
| R7 | R7 | R7 | R7 | R7 | R7 |
| R8 | R8 | R8 | R8 | R8 | R8_FIQ |
| R9 | R9 | R9 | R9 | R9 | R9_FIQ |
| R10 | R10 | R10 | R10 | R10 | R10_FIQ |
| R11 | R11 | R11 | R11 | R11 | R11_FIQ |
| R12 | R12 | R12 | R12 | R12 | R12_FIQ |
| R13 | R13_SVC | R13_ABORT | R13_UNDEF | R13_IRQ | R13_FIQ |
| R14 | R14_SVC | R14_ABORT | R14_UNDEF | R14_IRQ | R14_FIQ |
| PC | PC | PC | PC | PC | PC |
| CPSR | CPSR | CPSR | CPSR | CPSR | CPSR |
| | SPSR_SVC | SPSR_ABORT | SPSR_UNDEF | SPSR_IRQ | SPSR_FIQ |

 Mode-specific banked registers

The ARM state register set contains 16 directly-accessible registers, r0 to r15, and an additional register, the Current Program Status Register (CPSR). Registers r0 to r13 are general-purpose registers used to hold either data or address values. Register r14 is used as a Link register that holds a value (return address) of r15 when BL or BLX is executed. Register r15 is used as a program counter (PC), whereas the Current Program Status Register (CPSR) contains condition code flags and the current mode bits.

In privileged modes (FIQ, Supervisor, Abort, IRQ, Undefined), mode-specific banked registers (r8 to r14 in FIQ mode or r13 to r14 in the other modes) become available. The corresponding banked registers r14_fiq, r14_svc, r14_abt, r14_irq, r14_und are similarly used to hold the values (return address for each mode) of r15 (PC) when interrupts and exceptions arise, or when BL or BLX instructions are executed within interrupt or exception routines. There is another register called Saved Program Status Register (SPSR) that becomes available in privileged modes instead of CPSR. This register contains condition code flags and the current mode bits saved as a result of the exception that caused entry to the current (privileged) mode.

In all modes and due to a software agreement, register r13 is used as stack pointer.

The use and the function of all the registers described above should obey ARM Procedure Call Standard (APCS) which defines:

- constraints on the use of registers
- stack conventions
- argument passing and result return

The Thumb state register set is a subset of the ARM state set. The programmer has direct access to:

- Eight general-purpose registers r0-r7
- Stack pointer, SP
- Link register, LR (ARM r14)
- PC
- CPSR

There are banked registers SPs, LRs and SPSRs for each privileged mode (for more details see the ARM9EJ-S Technical Reference Manual, ref. DDI0222B, revision r1p2 page 2-12).

10.3.7.1 Status Registers

The ARM9EJ-S core contains one CPSR, and five SPSRs for exception handlers to use. The program status registers:

- hold information about the most recently performed ALU operation
- control the enabling and disabling of interrupts
- set the processor operation mode

Figure 10-2. Status Register Format

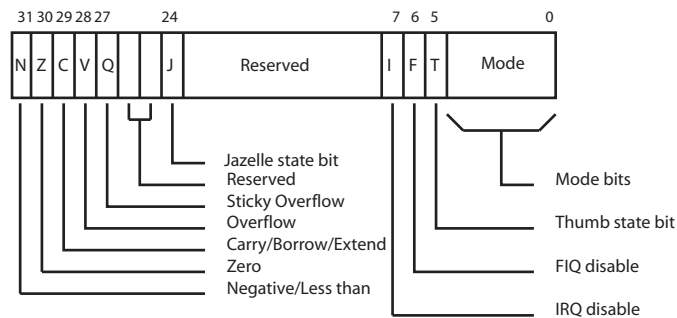

Figure 10-2 shows the status register format, where:

- N: Negative, Z: Zero, C: Carry, and V: Overflow are the four ALU flags
- The Sticky Overflow (Q) flag can be set by certain multiply and fractional arithmetic instructions like QADD, QDADD, QSUB, QDSUB, SMLAxy, and SMLAWy needed to achieve DSP operations. The Q flag is sticky in that, when set by an instruction, it remains set until explicitly cleared by an MSR instruction writing to the CPSR. Instructions cannot execute conditionally on the status of the Q flag.
- The J bit in the CPSR indicates when the ARM9EJ-S core is in Jazelle state, where:
 - J = 0: The processor is in ARM or Thumb state, depending on the T bit
 - J = 1: The processor is in Jazelle state.
- Mode: five bits to encode the current processor mode

10.3.7.2 Exceptions

Exception Types and Priorities

The ARM9EJ-S supports five types of exceptions. Each type drives the ARM9EJ-S in a privileged mode. The types of exceptions are:

- Fast interrupt (FIQ)
- Normal interrupt (IRQ)
- Data and Prefetched aborts (Abort)
- Undefined instruction (Undefined)
- Software interrupt and Reset (Supervisor)

When an exception occurs, the banked version of R14 and the SPSR for the exception mode are used to save the state.

More than one exception can happen at a time, therefore the ARM9EJ-S takes the arisen exceptions according to the following priority order:

- Reset (highest priority)
- Data Abort
- FIQ
- IRQ
- Prefetch Abort
- BKPT, Undefined instruction, and Software Interrupt (SWI) (Lowest priority)

The BKPT, or Undefined instruction, and SWI exceptions are mutually exclusive.

There is one exception in the priority scheme though, when FIQs are enabled and a Data Abort occurs at the same time as an FIQ, the ARM9EJ-S core enters the Data Abort handler, and proceeds immediately to FIQ vector. A normal return from the FIQ causes the Data Abort handler to resume execution. Data Aborts must have higher priority than FIQs to ensure that the transfer error does not escape detection.

Exception Modes and Handling

Exceptions arise whenever the normal flow of a program must be halted temporarily, for example, to service an interrupt from a peripheral.

When handling an ARM exception, the ARM9EJ-S core performs the following operations:

1. Preserves the address of the next instruction in the appropriate Link Register that corresponds to the new mode that has been entered. When the exception entry is from:
 - ARM and Jazelle states, the ARM9EJ-S copies the address of the next instruction into LR (current PC(r15) + 4 or PC + 8 depending on the exception).
 - THUMB state, the ARM9EJ-S writes the value of the PC into LR, offset by a value (current PC + 2, PC + 4 or PC + 8 depending on the exception) that causes the program to resume from the correct place on return.
2. Copies the CPSR into the appropriate SPSR.
3. Forces the CPSR mode bits to a value that depends on the exception.
4. Forces the PC to fetch the next instruction from the relevant exception vector.

The register r13 is also banked across exception modes to provide each exception handler with private stack pointer.

The ARM9EJ-S can also set the interrupt disable flags to prevent otherwise unmanageable nesting of exceptions.

When an exception has completed, the exception handler must move both the return value in the banked LR minus an offset to the PC and the SPSR to the CPSR. The offset value varies according to the type of exception. This action restores both PC and the CPSR.

The fast interrupt mode has seven private registers r8 to r14 (banked registers) to reduce or remove the requirement for register saving which minimizes the overhead of context switching.

The Prefetch Abort is one of the aborts that indicates that the current memory access cannot be completed. When a Prefetch Abort occurs, the ARM9EJ-S marks the prefetched instruction as invalid, but does not take the exception until the instruction reaches the Execute stage in the pipeline. If the instruction is not executed, for example because a branch occurs while it is in the pipeline, the abort does not take place.

The breakpoint (BKPT) instruction is a new feature of ARM9EJ-S that is destined to solve the problem of the Prefetch Abort. A breakpoint instruction operates as though the instruction caused a Prefetch Abort.

A breakpoint instruction does not cause the ARM9EJ-S to take the Prefetch Abort exception until the instruction reaches the Execute stage of the pipeline. If the instruction is not executed, for example because a branch occurs while it is in the pipeline, the breakpoint does not take place.

10.3.8 ARM Instruction Set Overview

The ARM instruction set is divided into:

- Branch instructions
- Data processing instructions
- Status register transfer instructions
- Load and Store instructions
- Coprocessor instructions
- Exception-generating instructions

ARM instructions can be executed conditionally. Every instruction contains a 4-bit condition code field (bits[31:28]).

Table 10-2 gives the ARM instruction mnemonic list.

Table 10-2. ARM Instruction Mnemonic List

| Mnemonic | Operation |
|----------|---------------------------------|
| MOV | Move |
| ADD | Add |
| SUB | Subtract |
| RSB | Reverse Subtract |
| CMP | Compare |
| TST | Test |
| AND | Logical AND |
| EOR | Logical Exclusive OR |
| MUL | Multiply |
| SMULL | Sign Long Multiply |
| SMLAL | Signed Long Multiply Accumulate |
| MSR | Move to Status Register |
| B | Branch |
| BX | Branch and Exchange |
| LDR | Load Word |
| LDRSH | Load Signed Halfword |
| LDRSB | Load Signed Byte |

| Mnemonic | Operation |
|----------|-----------------------------------|
| MVN | Move Not |
| ADC | Add with Carry |
| SBC | Subtract with Carry |
| RSC | Reverse Subtract with Carry |
| CMN | Compare Negated |
| TEQ | Test Equivalence |
| BIC | Bit Clear |
| ORR | Logical (inclusive) OR |
| MLA | Multiply Accumulate |
| UMULL | Unsigned Long Multiply |
| UMLAL | Unsigned Long Multiply Accumulate |
| MRS | Move From Status Register |
| BL | Branch and Link |
| SWI | Software Interrupt |
| STR | Store Word |
| | |
| | |

Table 10-2. ARM Instruction Mnemonic List (Continued)

| Mnemonic | Operation |
|----------|-------------------------------------|
| LDRH | Load Half Word |
| LDRB | Load Byte |
| LDRBT | Load Register Byte with Translation |
| LDRT | Load Register with Translation |
| LDM | Load Multiple |
| SWP | Swap Word |
| MCR | Move To Coprocessor |
| LDC | Load To Coprocessor |
| CDP | Coprocessor Data Processing |

| Mnemonic | Operation |
|----------|--------------------------------------|
| STRH | Store Half Word |
| STRB | Store Byte |
| STRBT | Store Register Byte with Translation |
| STRT | Store Register with Translation |
| STM | Store Multiple |
| SWPB | Swap Byte |
| MRC | Move From Coprocessor |
| STC | Store From Coprocessor |
| | |

10.3.9 New ARM Instruction Set

Table 10-3. New ARM Instruction Mnemonic List

| Mnemonic | Operation |
|--------------------|--|
| BXJ | Branch and exchange to Java |
| BLX ⁽¹⁾ | Branch, Link and exchange |
| SMLAx | Signed Multiply Accumulate 16 * 16 bit |
| SMLAL | Signed Multiply Accumulate Long |
| SMLAWy | Signed Multiply Accumulate 32 * 16 bit |
| SMULxy | Signed Multiply 16 * 16 bit |
| SMULWy | Signed Multiply 32 * 16 bit |
| QADD | Saturated Add |
| QDADD | Saturated Add with Double |
| QSUB | Saturated subtract |
| QDSUB | Saturated Subtract with double |

| Mnemonic | Operation |
|----------|---|
| MRRC | Move double from coprocessor |
| MCR2 | Alternative move of ARM reg to coprocessor |
| MCRR | Move double to coprocessor |
| CDP2 | Alternative Coprocessor Data Processing |
| BKPT | Breakpoint |
| PLD | Soft Preload, Memory prepare to load from address |
| STRD | Store Double |
| STC2 | Alternative Store from Coprocessor |
| LDRD | Load Double |
| LDC2 | Alternative Load to Coprocessor |
| CLZ | Count Leading Zeroes |

Note: 1. A Thumb BLX contains two consecutive Thumb instructions, and takes four cycles.

10.3.10 Thumb Instruction Set Overview

The Thumb instruction set is a re-encoded subset of the ARM instruction set.

The Thumb instruction set is divided into:

- Branch instructions
- Data processing instructions
- Load and Store instructions
- Load and Store multiple instructions
- Exception-generating instruction

Table 10-4 gives the Thumb instruction mnemonic list.

Table 10-4. Thumb Instruction Mnemonic List

| Mnemonic | Operation |
|----------|------------------------|
| MOV | Move |
| ADD | Add |
| SUB | Subtract |
| CMP | Compare |
| TST | Test |
| AND | Logical AND |
| EOR | Logical Exclusive OR |
| LSL | Logical Shift Left |
| ASR | Arithmetic Shift Right |
| MUL | Multiply |
| B | Branch |
| BX | Branch and Exchange |
| LDR | Load Word |
| LDRH | Load Half Word |
| LDRB | Load Byte |
| LDRSH | Load Signed Halfword |
| LDMIA | Load Multiple |
| PUSH | Push Register to stack |
| BCC | Conditional Branch |

| Mnemonic | Operation |
|----------|----------------------------|
| MVN | Move Not |
| ADC | Add with Carry |
| SBC | Subtract with Carry |
| CMN | Compare Negated |
| NEG | Negate |
| BIC | Bit Clear |
| ORR | Logical (inclusive) OR |
| LSR | Logical Shift Right |
| ROR | Rotate Right |
| BLX | Branch, Link, and Exchange |
| BL | Branch and Link |
| SWI | Software Interrupt |
| STR | Store Word |
| STRH | Store Half Word |
| STRB | Store Byte |
| LDRSB | Load Signed Byte |
| STMIA | Store Multiple |
| POP | Pop Register from stack |
| BKPT | Breakpoint |

10.4 CP15 Coprocessor

Coprocessor 15, or System Control Coprocessor CP15, is used to configure and control all the items in the list below:

- ARM9EJ-S
- Caches (ICache, DCache and write buffer)
- TCM
- MMU
- Other system options

To control these features, CP15 provides 16 additional registers. See [Table 10-5](#).

Table 10-5. CP15 Registers

| Register | Name | Read/Write |
|----------|---|---------------------|
| 0 | ID Code ⁽¹⁾ | Read/Unpredictable |
| 0 | Cache type ⁽¹⁾ | Read/Unpredictable |
| 0 | TCM status ⁽¹⁾ | Read/Unpredictable |
| 1 | Control | Read/write |
| 2 | Translation Table Base | Read/write |
| 3 | Domain Access Control | Read/write |
| 4 | Reserved | None |
| 5 | Data fault Status ⁽¹⁾ | Read/write |
| 5 | Instruction fault status ⁽¹⁾ | Read/write |
| 6 | Fault Address | Read/write |
| 7 | Cache Operations | Read/Write |
| 8 | TLB operations | Unpredictable/Write |
| 9 | Cache lockdown ⁽²⁾ | Read/write |
| 9 | TCM region | Read/write |
| 10 | TLB lockdown | Read/write |
| 11 | Reserved | None |
| 12 | Reserved | None |
| 13 | FCSE PID ⁽¹⁾ | Read/write |
| 13 | Context ID ⁽¹⁾ | Read/Write |
| 14 | Reserved | None |
| 15 | Test configuration | Read/Write |

- Notes:
1. Register locations 0, 5 and 13 each provide access to more than one register. The register accessed depends on the value of the opcode_2 field.
 2. Register location 9 provides access to more than one register. The register accessed depends on the value of the CRm field.

10.4.1 CP15 Registers Access

CP15 registers can only be accessed in privileged mode by:

- MCR (Move to Coprocessor from ARM Register) instruction is used to write an ARM register to CP15.
- MRC (Move to ARM Register from Coprocessor) instruction is used to read the value of CP15 to an ARM register.

Other instructions like CDP, LDC, STC can cause an undefined instruction exception.

The assembler code for these instructions is:

```
MCR/MRC{cond} p15, opcode_1, Rd, CRn, CRm, opcode_2.
```

The MCR, MRC instructions bit pattern is shown below:

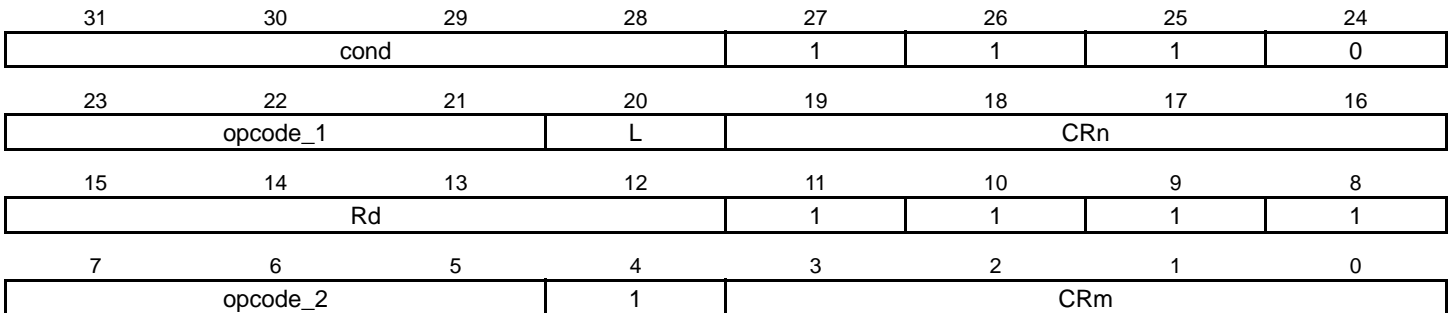

- **CRm[3:0]: Specified Coprocessor Action**

Determines specific coprocessor action. Its value is dependent on the CP15 register used. For details, refer to CP15 specific register behavior.

- **opcode_2[7:5]**

Determines specific coprocessor operation code. By default, set to 0.

- **Rd[15:12]: ARM Register**

Defines the ARM register whose value is transferred to the coprocessor. If R15 is chosen, the result is unpredictable.

- **CRn[19:16]: Coprocessor Register**

Determines the destination coprocessor register.

- **L: Instruction Bit**

0 = MCR instruction

1: MRC instruction

- **opcode_1[23:20]: Coprocessor Code**

Defines the coprocessor specific code. Value is c15 for CP15.

- **cond [31:28]: Condition**

For more details, see Chapter 2 in ARM926EJ-S TRM, ref. DDI0198B.

10.5 Memory Management Unit (MMU)

The ARM926EJ-S processor implements an enhanced ARM architecture v5 MMU to provide virtual memory features required by operating systems like Symbian OS®, Windows CE, and Linux. These virtual memory features are memory access permission controls and virtual to physical address translations.

The Virtual Address generated by the CPU core is converted to a Modified Virtual Address (MVA) by the FCSE (Fast Context Switch Extension) using the value in CP15 register13. The MMU translates modified virtual addresses to physical addresses by using a single, two-level page table set stored in physical memory. Each entry in the set contains the access permissions and the physical address that correspond to the virtual address.

The first level translation tables contain 4096 entries indexed by bits [31:20] of the MVA. These entries contain a pointer to either a 1 MB section of physical memory along with attribute information (access permissions, domain, etc.) or an entry in the second level translation tables; coarse table and fine table.

The second level translation tables contain two subtables, coarse table and fine table. An entry in the coarse table contains a pointer to both large pages and small pages along with access permissions. An entry in the fine table contains a pointer to large, small and tiny pages.

Table 10-6 shows the different attributes of each page in the physical memory.

Table 10-6. Mapping Details

| Mapping Name | Mapping Size | Access Permission By | Subpage Size |
|--------------|--------------|----------------------|--------------|
| Section | 1 Mbyte | Section | – |
| Large Page | 64 Kbytes | 4 separated subpages | 16 Kbytes |
| Small Page | 4 Kbytes | 4 separated subpages | 1 Kbyte |
| Tiny Page | 1 Kbyte | Tiny Page | – |

The MMU consists of:

- Access control logic
- Translation Look-aside Buffer (TLB)
- Translation table walk hardware

10.5.1 Access Control Logic

The access control logic controls access information for every entry in the translation table. The access control logic checks two pieces of access information: domain and access permissions. The domain is the primary access control mechanism for a memory region; there are 16 of them. It defines the conditions necessary for an access to proceed. The domain determines whether the access permissions are used to qualify the access or whether they should be ignored.

The second access control mechanism is access permissions that are defined for sections and for large, small and tiny pages. Sections and tiny pages have a single set of access permissions whereas large and small pages can be associated with 4 sets of access permissions, one for each subpage (quarter of a page).

10.5.2 Translation Look-aside Buffer (TLB)

The Translation Look-aside Buffer (TLB) caches translated entries and thus avoids going through the translation process every time. When the TLB contains an entry for the MVA (Modified Virtual Address), the access control logic determines if the access is permitted and outputs the appropriate physical address corresponding to the MVA. If access is not permitted, the MMU signals the CPU core to abort.

If the TLB does not contain an entry for the MVA, the translation table walk hardware is invoked to retrieve the translation information from the translation table in physical memory.

10.5.3 Translation Table Walk Hardware

The translation table walk hardware is a logic that traverses the translation tables located in physical memory, gets the physical address and access permissions and updates the TLB.

The number of stages in the hardware table walking is one or two depending whether the address is marked as a section-mapped access or a page-mapped access.

There are three sizes of page-mapped accesses and one size of section-mapped access. Page-mapped accesses are for large pages, small pages and tiny pages. The translation process always begins with a level one fetch. A section-mapped access requires only a level one fetch, but a page-mapped access requires an additional level two fetch. For further details on the MMU, please refer to chapter 3 in ARM926EJ-S Technical Reference Manual, ref. DDI0198B.

10.5.4 MMU Faults

The MMU generates an abort on the following types of faults:

- Alignment faults (for data accesses only)
- Translation faults
- Domain faults
- Permission faults

The access control mechanism of the MMU detects the conditions that produce these faults. If the fault is a result of memory access, the MMU aborts the access and signals the fault to the CPU core. The MMU retains status and address information about faults generated by the data accesses in the data fault status register and fault address register. It also retains the status of faults generated by instruction fetches in the instruction fault status register.

The fault status register (register 5 in CP15) indicates the cause of a data or prefetch abort, and the domain number of the aborted access when it happens. The fault address register (register 6 in CP15) holds the MVA associated with the access that caused the Data Abort. For further details on MMU faults, please refer to chapter 3 in ARM926EJ-S Technical Reference Manual, ref. DDI0198B.

10.6 Caches and Write Buffer

The ARM926EJ-S contains a 16 KB Instruction Cache (ICache), a 16 KB Data Cache (DCache), and a write buffer. Although the ICache and DCache share common features, each still has some specific mechanisms.

The caches (ICache and DCache) are four-way set associative, addressed, indexed and tagged using the Modified Virtual Address (MVA), with a cache line length of eight words with two dirty bits for the DCache. The ICache and DCache provide mechanisms for cache lockdown, cache pollution control, and line replacement.

A new feature is now supported by ARM926EJ-S caches called allocate on read-miss commonly known as wrapping. This feature enables the caches to perform critical word first cache refilling. This means that when a request for a word causes a read-miss, the cache performs an AHB access. Instead of loading the whole line (eight words), the cache loads the critical word first, so the processor can reach it quickly, and then the remaining words, no matter where the word is located in the line.

The caches and the write buffer are controlled by the CP15 register 1 (Control), CP15 register 7 (cache operations) and CP15 register 9 (cache lockdown).

10.6.1 Instruction Cache (ICache)

The ICache caches fetched instructions to be executed by the processor. The ICache can be enabled by writing 1 to I bit of the CP15 Register 1 and disabled by writing 0 to this same bit.

When the MMU is enabled, all instruction fetches are subject to translation and permission checks. If the MMU is disabled, all instructions fetches are cachable, no protection checks are made and the physical address is flat-

mapped to the modified virtual address. With the MVA use disabled, context switching incurs ICache cleaning and/or invalidating.

When the ICache is disabled, all instruction fetches appear on external memory (AHB) (see Tables 4-1 and 4-2 in page 4-4 in ARM926EJ-S TRM, ref. DDI0198B).

On reset, the ICache entries are invalidated and the ICache is disabled. For best performance, ICache should be enabled as soon as possible after reset.

10.6.2 Data Cache (DCache) and Write Buffer

ARM926EJ-S includes a DCache and a write buffer to reduce the effect of main memory bandwidth and latency on data access performance. The operations of DCache and write buffer are closely connected.

10.6.2.1 DCache

The DCache needs the MMU to be enabled. All data accesses are subject to MMU permission and translation checks. Data accesses that are aborted by the MMU do not cause linefills or data accesses to appear on the AMBA AHB interface. If the MMU is disabled, all data accesses are noncachable, nonbufferable, with no protection checks, and appear on the AHB bus. All addresses are flat-mapped, VA = MVA = PA, which incurs DCache cleaning and/or invalidating every time a context switch occurs.

The DCache stores the Physical Address Tag (PA Tag) from which every line was loaded and uses it when writing modified lines back to external memory. This means that the MMU is not involved in write-back operations.

Each line (8 words) in the DCache has two dirty bits, one for the first four words and the other one for the second four words. These bits, if set, mark the associated half-lines as dirty. If the cache line is replaced due to a linefill or a cache clean operation, the dirty bits are used to decide whether all, half or none is written back to memory.

DCache can be enabled or disabled by writing either 1 or 0 to bit C in register 1 of CP15 (see Tables 4-3 and 4-4 on page 4-5 in ARM926EJ-S TRM, ref. DDI0222B).

The DCache supports write-through and write-back cache operations, selected by memory region using the C and B bits in the MMU translation tables.

The DCache contains an eight data word entry, single address entry write-back buffer used to hold write-back data for cache line eviction or cleaning of dirty cache lines.

The Write Buffer can hold up to 16 words of data and four separate addresses. DCache and Write Buffer operations are closely connected as their configuration is set in each section by the page descriptor in the MMU translation table.

10.6.2.2 Write Buffer

The ARM926EJ-S contains a write buffer that has a 16-word data buffer and a four- address buffer. The write buffer is used for all writes to a bufferable region, write-through region and write-back region. It also allows to avoid stalling the processor when writes to external memory are performed. When a store occurs, data is written to the write buffer at core speed (high speed). The write buffer then completes the store to external memory at bus speed (typically slower than the core speed). During this time, the ARM9EJ-S processor can preform other tasks.

DCache and Write Buffer support write-back and write-through memory regions, controlled by C and B bits in each section and page descriptor within the MMU translation tables.

Write-though Operation

When a cache write hit occurs, the DCache line is updated. The updated data is then written to the write buffer which transfers it to external memory.

When a cache write miss occurs, a line, chosen by round robin or another algorithm, is stored in the write buffer which transfers it to external memory.

Write-back Operation

When a cache write hit occurs, the cache line or half line is marked as dirty, meaning that its contents are not up-to-date with those in the external memory.

When a cache write miss occurs, a line, chosen by round robin or another algorithm, is stored in the write buffer which transfers it to external memory.

10.7 Tightly-Coupled Memory Interface

10.7.1 TCM Description

The ARM926EJ-S processor features a Tightly-Coupled Memory (TCM) interface, which enables separate instruction and data TCMs (ITCM and DTCM) to be directly reached by the processor. TCMs are used to store real-time and performance critical code, they also provide a DMA support mechanism. Unlike AHB accesses to external memories, accesses to TCMs are fast and deterministic and do not incur bus penalties.

The user has the possibility to independently configure each TCM size with values within the following ranges, [0 KB, 64 KB] for ITCM size and [0 KB, 64 KB] for DTCM size.

TCMs can be configured by two means: HMATRIX TCM register and TCM region register (register 9) in CP15 and both steps should be performed. HMATRIX TCM register sets TCM size whereas TCM region register (register 9) in CP15 maps TCMs and enables them.

The data side of the ARM9EJ-S core is able to access the ITCM. This is necessary to enable code to be loaded into the ITCM, for SWI and emulated instruction handlers, and for accesses to PC-relative literal pools.

10.7.2 Enabling and Disabling TCMs

Prior to any enabling step, the user should configure the TCM sizes in HMATRIX TCM register. Then enabling TCMs is performed by using TCM region register (register 9) in CP15. The user should use the same sizes as those put in HMATRIX TCM register. For further details and programming tips, please refer to chapter 2.3 in ARM926EJ-S TRM, ref. DDI0222B.

10.7.3 TCM Mapping

The TCMs can be located anywhere in the memory map, with a single region available for ITCM and a separate region available for DTCM. The TCMs are physically addressed and can be placed anywhere in physical address space. However, the base address of a TCM must be aligned to its size, and the DTCM and ITCM regions must not overlap. TCM mapping is performed by using TCM region register (register 9) in CP15. The user should input the right mapping address for TCMs.

10.8 Bus Interface Unit

The ARM926EJ-S features a Bus Interface Unit (BIU) that arbitrates and schedules AHB requests. The BIU implements a multi-layer AHB, based on the AHB-Lite protocol, that enables parallel access paths between multiple AHB masters and slaves in a system. This is achieved by using a more complex interconnection matrix and gives the benefit of increased overall bus bandwidth, and a more flexible system architecture.

The multi-master bus architecture has a number of benefits:

- It allows the development of multi-master systems with an increased bus bandwidth and a flexible architecture.
- Each AHB layer becomes simple because it only has one master, so no arbitration or master-to-slave muxing is required. AHB layers, implementing AHB-Lite protocol, do not have to support request and grant, nor do they have to support retry and split transactions.
- The arbitration becomes effective when more than one master wants to access the same slave simultaneously.

10.8.1 Supported Transfers

The ARM926EJ-S processor performs all AHB accesses as single word, bursts of four words, or bursts of eight words. Any ARM9EJ-S core request that is not 1, 4, 8 words in size is split into packets of these sizes. Note that the Atmel bus is AHB-Lite protocol compliant, hence it does not support split and retry requests.

Table 10-7 gives an overview of the supported transfers and different kinds of transactions they are used for.

Table 10-7. Supported Transfers

| HBurst[2:0] | Description | Operation |
|-------------|-------------------------------|--|
| Single | Single transfer | Single transfer of word, half word, or byte: <ul style="list-style-type: none">• data write (NCNB, NCB, WT, or WB that has missed in DCache)• data read (NCNB or NCB)• NC instruction fetch (prefetched and non-prefetched)• page table walk read |
| Incr4 | Four-word incrementing burst | Half-line cache write-back, Instruction prefetch, if enabled. Four-word burst NCNB, NCB, WT, or WB write. |
| Incr8 | Eight-word incrementing burst | Full-line cache write-back, eight-word burst NCNB, NCB, WT, or WB write. |
| Wrap8 | Eight-word wrapping burst | Cache linefill |

10.8.2 Thumb Instruction Fetches

All instructions fetches, regardless of the state of ARM9EJ-S core, are made as 32-bit accesses on the AHB. If the ARM9EJ-S is in Thumb state, then two instructions can be fetched at a time.

10.8.3 Address Alignment

The ARM926EJ-S BIU performs address alignment checking and aligns AHB addresses to the necessary boundary. 16-bit accesses are aligned to halfword boundaries, and 32-bit accesses are aligned to word boundaries.

11. Debug and Test

11.1 Overview

The SAM9261 features a number of complementary debug and test capabilities. A common JTAG/ICE (In-Circuit Emulator) port is used for standard debugging functions, such as downloading code and single-stepping through programs. An ETM (Embedded Trace Macrocell) provides more sophisticated debug features such as address and data comparators, half-rate clock mode, counters, sequencer and FIFO. The Debug Unit provides a two-pin UART that can be used to upload an application into internal SRAM. It manages the interrupt handling of the internal COMMTX and COMMRX signals that trace the activity of the Debug Communication Channel.

A set of dedicated debug and test input/output pins gives direct access to these capabilities from a PC-based test environment.

11.2 Block Diagram

Figure 11-1. Debug and Test Block Diagram

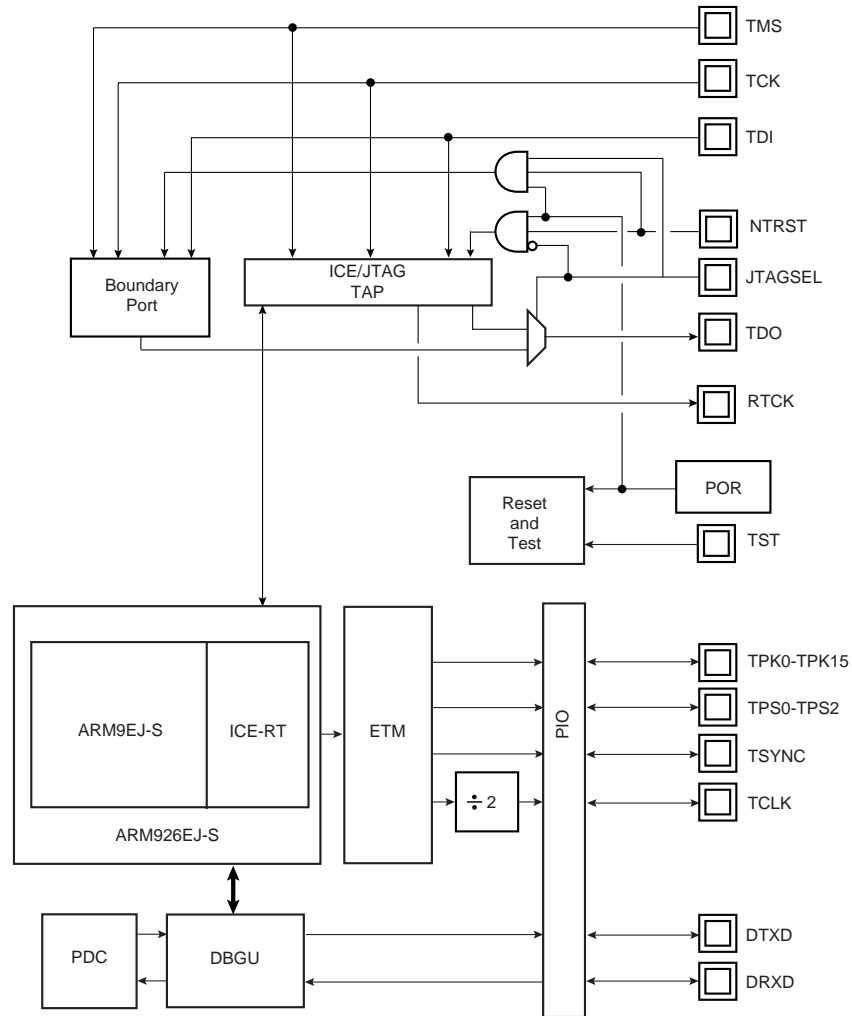

TAP: Test Access Port

11.3 Application Examples

11.3.1 Debug Environment

Figure 11-2 shows a complete debug environment example. The ICE/JTAG interface is used for standard debugging functions, such as downloading code and single-stepping through the program. The Trace Port interface is used for tracing information. A software debugger running on a personal computer provides the user interface for configuring a Trace Port interface utilizing the ICE/JTAG interface.

Figure 11-2. Application Debug and Trace Environment Example

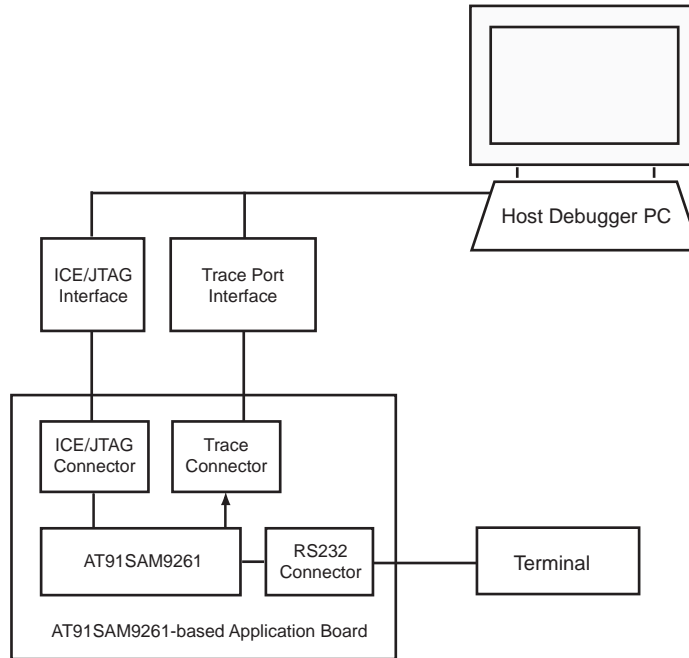

11.3.2 Test Environment

Figure 11-3 shows a test environment example. Test vectors are sent and interpreted by the tester. In this example, the “board in test” is designed using a number of JTAG-compliant devices. These devices can be connected to form a single scan chain.

Figure 11-3. Application Test Environment Example

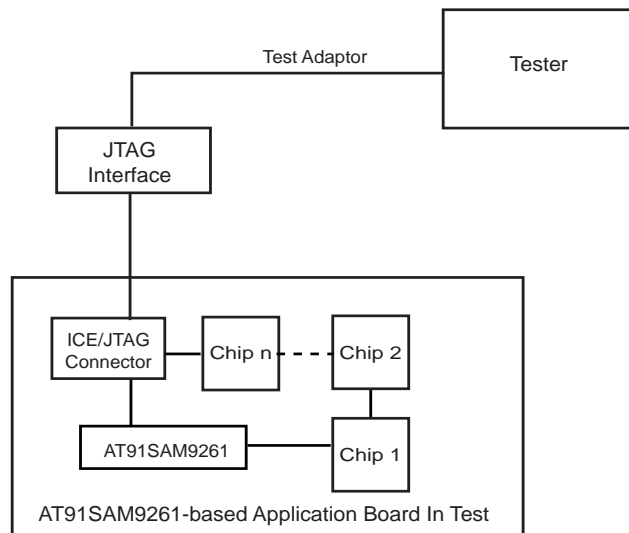

11.4 Debug and Test Pin Description

Table 11-1. Debug and Test Pin List

| Pin Name | Function | Type | Active Level |
|---------------------|------------------------------|--------------|--------------|
| Reset/Test | | | |
| NRST | Microcontroller Reset | Input/Output | Low |
| TST | Test Mode Select | Input | High |
| ICE and JTAG | | | |
| TCK | Test Clock | Input | |
| TDI | Test Data In | Input | |
| TDO | Test Data Out | Output | |
| TMS | Test Mode Select | Input | |
| NTRST | Test Reset Signal | Input | Low |
| RTCK | Returned Test Clock | Output | |
| JTAGSEL | JTAG Selection | Input | |
| ETM | | | |
| TSYNC | Trace Synchronization Signal | Output | |
| TCLK | Trace Clock | Output | |
| TPS0–TPS2 | Trace ARM Pipeline Status | Output | |
| TPK0–TPK15 | Trace Packet Port | Output | |
| Debug Unit | | | |
| DRXD | Debug Receive Data | Input | |
| DTXD | Debug Transmit Data | Output | |

11.5 Functional Description

11.5.1 Test Pin

One dedicated pin, TST, is used to define the device operating mode. The user must make sure that this pin is tied at low level to ensure normal operating conditions. Other values associated with this pin are reserved for manufacturing test.

11.5.2 Embedded In-circuit Emulator

The ARM9EJ-S EmbeddedICE-RT™ is supported via the ICE/JTAG port. It is connected to a host computer via an ICE interface. Debug support is implemented using an ARM9EJ-S core embedded within the ARM926EJ-S. The internal state of the ARM926EJ-S is examined through an ICE/JTAG port which allows instructions to be serially inserted into the pipeline of the core without using the external data bus. Therefore, when in debug state, a store-multiple (STM) can be inserted into the instruction pipeline. This exports the contents of the ARM9EJ-S registers. This data can be serially shifted out without affecting the rest of the system.

There are two scan chains inside the ARM9EJ-S processor which support testing, debugging, and programming of the EmbeddedICE-RT. The scan chains are controlled by the ICE/JTAG port.

EmbeddedICE mode is selected when JTAGSEL is low. It is not possible to switch directly between ICE and JTAG operations. A chip reset must be performed after JTAGSEL is changed.

For further details on the EmbeddedICE-RT, see the ARM document ARM9EJ-S Technical Reference Manual (DDI 0222A).

11.5.3 JTAG Signal Description

TMS is the Test Mode Select input which controls the transitions of the test interface state machine.

TDI is the Test Data Input line which supplies the data to the JTAG registers (Boundary Scan Register, Instruction Register, or other data registers).

TDO is the Test Data Output line which is used to serially output the data from the JTAG registers to the equipment controlling the test. It carries the sampled values from the boundary scan chain (or other JTAG registers) and propagates them to the next chip in the serial test circuit.

NTRST (optional in IEEE Standard 1149.1) is a Test-ReSeT input which is mandatory in ARM cores and used to reset the debug logic. On Atmel ARM926EJ-S-based cores, NTRST is a Power On Reset output. It is asserted on power on. If necessary, the user can also reset the debug logic with the NTRST pin assertion during 2.5 MCK periods.

TCK is the Test Clock input which enables the test interface. TCK is pulsed by the equipment controlling the test and not by the tested device. It can be pulsed at any frequency. Note the maximum JTAG clock rate on ARM926EJ-S cores is 1/6th the clock of the CPU. This gives 5.45 kHz maximum initial JTAG clock rate for an ARM9E running from the 32.768 kHz slow clock.

RTCK is the Return Test Clock. Not an IEEE Standard 1149.1 signal added for a better clock handling by emulators. From some ICE Interface probes, this return signal can be used to synchronize the TCK clock and take not care about the given ratio between the ICE Interface clock and system clock equal to 1/6th. This signal is only available in JTAG ICE Mode and not in boundary scan mode.

11.5.4 Debug Unit

The Debug Unit provides a two-pin (DXRD and TXRD) USART that can be used for several debug and trace purposes and offers an ideal means for in-situ programming solutions and debug monitor communication. Moreover, the association with two Peripheral DMA Controller channels permits packet handling of these tasks with processor time reduced to a minimum.

The Debug Unit also manages the interrupt handling of the COMMTX and COMMRX signals that come from the ICE and that trace the activity of the Debug Communication Channel. The Debug Unit allows blockage of access to the system through the ICE interface.

A specific register, the Debug Unit Chip ID Register, gives information about the product version and its internal configuration.

The SAM9261 Debug Unit Chip ID value is 0x0197 03A0 on 32-bit width.

For further details on the Debug Unit, see [Section 27. "Debug Unit \(DBGU\)" on page 301](#).

11.5.5 Embedded Trace Macrocell

The SAM9261 features an Embedded Trace Macrocell (ETM), which is closely connected to the ARM926EJ-S Processor. The Embedded Trace is a standard Medium+ level implementation and contains the following resources:

- Four pairs of address comparators
- Two data comparators
- Eight memory map decoder inputs
- Two 16-bit counters
- One 3-stage sequencer
- Four external inputs
- One external output
- One 45-byte FIFO

The Embedded Trace Macrocell of the SAM9261 works in half-rate clock mode and thus integrates a clock divider. Thus the maximum frequency of all the trace port signals does not exceed one half of the ARM926EJ-S clock speed.

The Embedded Trace Macrocell input and output resources are not used in the SAM9261.

The Embedded Trace is a real-time trace module with the capability of tracing the ARM9EJ-S instructions and data.

For further details on Embedded Trace Macrocell, see the ARM documents:

- ETM9 (Rev2p2) Technical Reference Manual (DDI 0157F)
- Embedded Trace Macrocell Specification (IHI 0014J)

11.5.5.1 Trace Port

The Trace Port is made up of the following pins:

- TSYNC—the synchronization signal (Indicates the start of a branch sequence on the trace packet port.)
- TCLK—the Trace Port clock, half-rate of the ARM926EJ-S processor clock.
- TPS0 to TPS2—indicate the processor state at each trace clock edge.
- TPK0 to TPK15—the Trace Packet data value.

The trace packet information (address, data) is associated with the processor state indicated by TPS. Some processor states have no additional data associated with the Trace Packet Port (i.e., failed condition code of an instruction). The packet is eight bits wide, and up to two packets can be output per cycle.

Figure 11-4. ETM9 Block

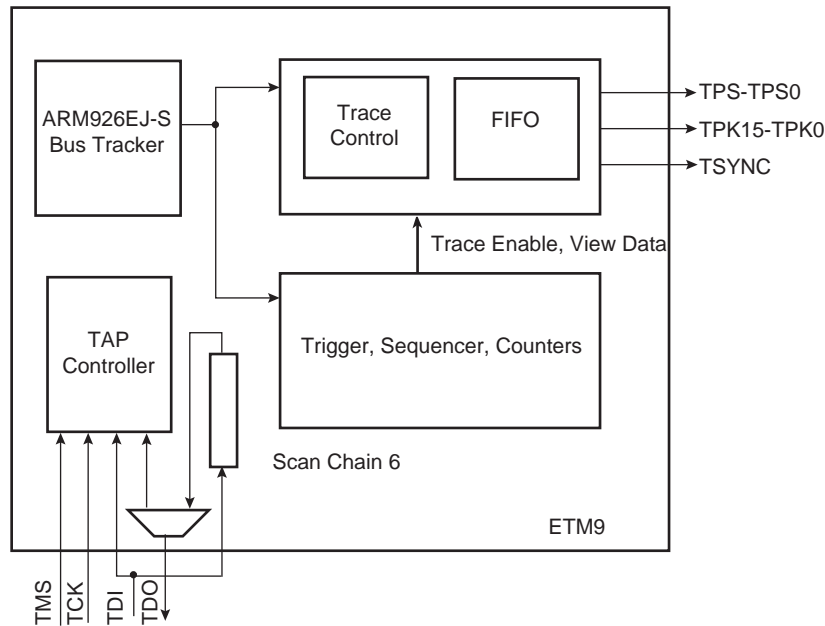

11.5.5.2 Implementation Details

This section gives an overview of the Embedded Trace resources.

Three-state Sequencer

The sequencer has three possible next states (one dedicated to itself and two others) and can change on every clock cycle. The state transition is controlled with internal events. If the user needs multiple-stage trigger schemes, the trigger event is based on a sequencer state.

Address Comparator

In single mode, address comparators compare either the instruction address or the data address against the user-programmed address.

In range mode, the address comparators are arranged in pairs to form a virtual address range resource.

Details of the address comparator programming are:

- The first comparator is programmed with the range start address.
- The second comparator is programmed with the range end address.
- The resource matches if the address is within the following range:
 - (address \geq range start address) AND (address $<$ range end address)
- Unpredictable behavior occurs if the two address comparators are not configured in the same way.

Data Comparator

Each full address comparator is associated with a specific data comparator. A data comparator is used to observe the data bus only when load and store operations occur.

A data comparator has both a value register and a mask register, therefore it is possible to compare only certain bits of a preprogrammed value against the data bus.

Memory Decoder Inputs

The eight memory map decoder inputs are connected to custom address decoders. The address decoders divide the memory into regions of on-chip SRAM, on-chip ROM, and peripherals. The address decoders also optimize the ETM9 trace trigger.

Table 11-2. ETM Memory Map Inputs Layout

| Product Resource | Area | Access Type | Start Address | End Address |
|------------------------|----------|-------------|---------------|-------------|
| SRAM | Internal | Data | 0x0000 0000 | 0x002F FFFF |
| SRAM | Internal | Fetch | 0x0000 0000 | 0x002F FFFF |
| ROM | Internal | Data | 0x0040 0000 | 0x004F FFFF |
| ROM | Internal | Fetch | 0x0040 0000 | 0x004F FFFF |
| External Bus Interface | External | Data | 0x1000 0000 | 0x8FFF FFFF |
| External Bus Interface | External | Fetch | 0x1000 0000 | 0x8FFF FFFF |
| User Peripherals | Internal | Data | 0xF000 0000 | 0xFFFF BFFF |
| System Peripherals | Internal | Data | 0xFFFF C000 | 0xFFFF FFFF |

FIFO

A 45-byte FIFO is used to store data tracing. The FIFO is used to separate the pipeline status from the trace packet, thus the FIFO can be used to buffer trace packets.

A FIFO overflow is detected by the embedded trace macrocell when the FIFO is full or when the FIFO has fewer bytes than the user-programmed number.

Half-rate Clocking Mode

The ETM9 is implemented in half-rate mode that allows both rising and falling edge data tracing of the trace clock. The half-rate mode is implemented to maintain the signal clock integrity of high-speed systems (up to 100 MHz).

Figure 11-5. Half-rate Clocking Mode

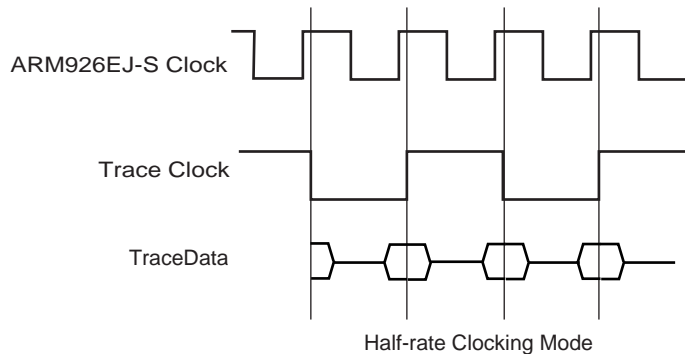

Care must be taken on the choice of the trace capture system as it needs to support half-rate clock functionality.

11.5.5.3 Application Board Restriction

The TCLK signal needs to be set with care, some timing parameters are required.

The specified target system connector is the AMP Mictor connector.

The connector must be oriented on the application board as shown in [Figure 11-6](#). The view of the PCB is shown from above with the trace connector mounted near the edge of the board. This allows the Trace Port Analyzer to minimize the physical intrusiveness of the interconnected target.

Figure 11-6. AMP Mictor Connector Orientation

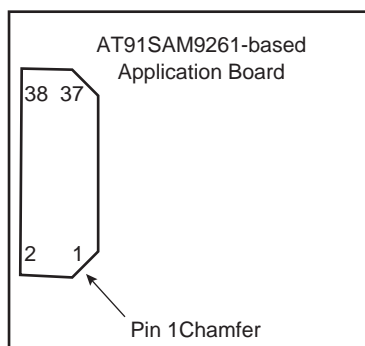

11.5.6 IEEE 1149.1 JTAG Boundary Scan

IEEE 1149.1 JTAG Boundary Scan allows pin-level access independent of the device packaging technology.

IEEE 1149.1 JTAG Boundary Scan is enabled when JTAGSEL is high. The SAMPLE, EXTEST and BYPASS functions are implemented. In ICE debug mode, the ARM processor responds with a non-JTAG chip ID that identifies the processor to the ICE system. This is not IEEE 1149.1 JTAG-compliant.

It is not possible to switch directly between JTAG and ICE operations. A chip reset must be performed after JTAGSEL is changed.

A Boundary-scan Descriptor Language (BSDL) file is provided to set up test.

11.5.6.1 JTAG Boundary-scan Register

The Boundary-scan Register (BSR) contains 484 bits that correspond to active pins and associated control signals.

Each SAM9261 input/output pin corresponds to a 3-bit register in the BSR. The OUTPUT bit contains data that can be forced on the pad. The INPUT bit facilitates the observability of data applied to the pad. The CONTROL bit selects the direction of the pad.

Table 11-3. SAM9261 JTAG Boundary Scan Register

| Bit Number | Pin Name | Pin Type | Associated BSR Cells |
|------------|--|----------|----------------------|
| 483 | A18 | OUT | OUTPUT |
| 482 | A[22:16] | | CONTROL |
| 481 | A19 | OUT | OUTPUT |
| 480 | A20 | OUT | OUTPUT |
| 479 | A21 | OUT | OUTPUT |
| 478 | A22 | OUT | OUTPUT |
| 477 | NCS0 | OUT | OUTPUT |
| 476 | A[7:0] | | CONTROL |
| 475 | NCS1 | OUT | OUTPUT |
| 474 | NCS0/NCS1/NCS2/NCS3/NRD/NWR0/NWR1/NWR3 | | CONTROL |
| 473 | NCS2 | OUT | OUTPUT |
| 472 | NCS3 | OUT | OUTPUT |
| 471 | NRD | OUT | OUTPUT |

Table 11-3. SAM9261 JTAG Boundary Scan Register (Continued)

| Bit Number | Pin Name | Pin Type | Associated BSR Cells |
|------------|-----------------------------|----------|----------------------|
| 470 | NWR0 | IN/OUT | INPUT |
| 469 | | | OUTPUT |
| 468 | NWR1 | IN/OUT | INPUT |
| 467 | | | OUTPUT |
| 466 | | internal | |
| 465 | NWR3 | OUT | OUTPUT |
| 464 | SDRAMCKE | OUT | OUTPUT |
| 463 | SDRAMCKE/RAS/CAS/SDA10/SDWE | | CONTROL |
| 462 | SDRAMCLK | IN/OUT | INPUT |
| 461 | | | OUTPUT |
| 460 | | | CONTROL |
| 459 | RAS | OUT | OUTPUT |
| 458 | CAS | OUT | OUTPUT |
| 457 | SDWE | OUT | OUTPUT |
| 456 | D0 | IN/OUT | INPUT |
| 455 | | | OUTPUT |
| 454 | | | CONTROL |
| 453 | | internal | |
| 452 | D1 | IN/OUT | INPUT |
| 451 | | | OUTPUT |
| 450 | | | CONTROL |
| 449 | D2 | IN/OUT | INPUT |
| 448 | | | OUTPUT |
| 447 | | | CONTROL |
| 446 | D3 | IN/OUT | INPUT |
| 445 | | | OUTPUT |
| 444 | | | CONTROL |
| 443 | D4 | IN/OUT | INPUT |
| 442 | | | OUTPUT |
| 441 | | | CONTROL |
| 440 | | internal | |
| 439 | D5 | IN/OUT | INPUT |
| 438 | | | OUTPUT |
| 437 | | | CONTROL |
| 436 | D6 | IN/OUT | INPUT |
| 435 | | | OUTPUT |
| 434 | | | CONTROL |

Table 11-3. SAM9261 JTAG Boundary Scan Register (Continued)

| Bit Number | Pin Name | Pin Type | Associated BSR Cells |
|------------|----------|----------|----------------------|
| 433 | D7 | IN/OUT | INPUT |
| 432 | | | OUTPUT |
| 431 | | | CONTROL |
| 430 | D8 | IN/OUT | INPUT |
| 429 | | | OUTPUT |
| 428 | | | CONTROL |
| 427 | | internal | |
| 426 | D9 | IN/OUT | INPUT |
| 425 | | | OUTPUT |
| 424 | | | CONTROL |
| 423 | D10 | IN/OUT | INPUT |
| 422 | | | OUTPUT |
| 421 | | | CONTROL |
| 420 | D11 | IN/OUT | INPUT |
| 419 | | | OUTPUT |
| 418 | | | CONTROL |
| 417 | D12 | IN/OUT | INPUT |
| 416 | | | OUTPUT |
| 415 | | | CONTROL |
| 414 | | internal | |
| 413 | D13 | IN/OUT | INPUT |
| 412 | | | OUTPUT |
| 411 | | | CONTROL |
| 410 | D14 | IN/OUT | INPUT |
| 409 | | | OUTPUT |
| 408 | | | CONTROL |
| 407 | D15 | IN/OUT | INPUT |
| 406 | | | OUTPUT |
| 405 | | | CONTROL |
| 404 | PC16 | IN/OUT | INPUT |
| 403 | | | OUTPUT |
| 402 | | | CONTROL |
| 401 | | internal | |
| 400 | PC17 | IN/OUT | INPUT |
| 399 | | | OUTPUT |
| 398 | | | CONTROL |
| 397 | | internal | |

Table 11-3. SAM9261 JTAG Boundary Scan Register (Continued)

| Bit Number | Pin Name | Pin Type | Associated BSR Cells |
|------------|----------|----------|----------------------|
| 396 | PC18 | IN/OUT | INPUT |
| 395 | | | OUTPUT |
| 394 | | | CONTROL |
| 393 | | internal | |
| 392 | PC19 | IN/OUT | INPUT |
| 391 | | | OUTPUT |
| 390 | | | CONTROL |
| 389 | | internal | |
| 388 | PC30 | IN/OUT | INPUT |
| 387 | | | OUTPUT |
| 386 | | | CONTROL |
| 385 | | internal | |
| 384 | PC31 | IN/OUT | INPUT |
| 383 | | | OUTPUT |
| 382 | | | CONTROL |
| 381 | | internal | |
| 380 | PC20 | IN/OUT | INPUT |
| 379 | | | OUTPUT |
| 378 | | | CONTROL |
| 377 | | internal | |
| 376 | PC21 | IN/OUT | INPUT |
| 375 | | | OUTPUT |
| 374 | | | CONTROL |
| 373 | | internal | |
| 372 | PC22 | IN/OUT | INPUT |
| 371 | | | OUTPUT |
| 370 | | | CONTROL |
| 369 | | internal | |
| 368 | PC23 | IN/OUT | INPUT |
| 367 | | | OUTPUT |
| 366 | | | CONTROL |
| 365 | | internal | |
| 364 | PC24 | IN/OUT | INPUT |
| 363 | | | OUTPUT |
| 362 | | | CONTROL |
| 361 | | internal | |

Table 11-3. SAM9261 JTAG Boundary Scan Register (Continued)

| Bit Number | Pin Name | Pin Type | Associated BSR Cells |
|------------|----------|----------|----------------------|
| 360 | PC25 | IN/OUT | INPUT |
| 359 | | | OUTPUT |
| 358 | | | CONTROL |
| 357 | | internal | |
| 356 | PC26 | IN/OUT | INPUT |
| 355 | | | OUTPUT |
| 354 | | | CONTROL |
| 353 | | internal | |
| 352 | PC27 | IN/OUT | INPUT |
| 351 | | | OUTPUT |
| 350 | | | CONTROL |
| 349 | | internal | |
| 348 | PC28 | IN/OUT | INPUT |
| 347 | | | OUTPUT |
| 346 | | | CONTROL |
| 345 | | internal | |
| 344 | PC29 | IN/OUT | INPUT |
| 343 | | | OUTPUT |
| 342 | | | CONTROL |
| 341 | | internal | |
| 340 | PC0 | IN/OUT | INPUT |
| 339 | | | OUTPUT |
| 338 | | | CONTROL |
| 337 | | internal | |
| 336 | PC1 | IN/OUT | INPUT |
| 335 | | | OUTPUT |
| 334 | | | CONTROL |
| 333 | | internal | |
| 332 | PC2 | IN/OUT | INPUT |
| 331 | | | OUTPUT |
| 330 | | | CONTROL |
| 329 | | internal | |
| 328 | PC3 | IN/OUT | INPUT |
| 327 | | | OUTPUT |
| 326 | | | CONTROL |
| 325 | | internal | |

Table 11-3. SAM9261 JTAG Boundary Scan Register (Continued)

| Bit Number | Pin Name | Pin Type | Associated BSR Cells |
|------------|----------|----------|----------------------|
| 324 | PC4 | IN/OUT | INPUT |
| 323 | | | OUTPUT |
| 322 | | | CONTROL |
| 321 | | internal | |
| 320 | PC5 | IN/OUT | INPUT |
| 319 | | | OUTPUT |
| 318 | | | CONTROL |
| 317 | | internal | |
| 316 | PC6 | IN/OUT | INPUT |
| 315 | | | OUTPUT |
| 314 | | | CONTROL |
| 313 | | internal | |
| 312 | PC7 | IN/OUT | INPUT |
| 311 | | | OUTPUT |
| 310 | | | CONTROL |
| 309 | | internal | |
| 308 | PC8 | IN/OUT | INPUT |
| 307 | | | OUTPUT |
| 306 | | | CONTROL |
| 305 | | internal | |
| 304 | PC9 | IN/OUT | INPUT |
| 303 | | | OUTPUT |
| 302 | | | CONTROL |
| 301 | | internal | |
| 300 | PC10 | IN/OUT | INPUT |
| 299 | | | OUTPUT |
| 298 | | | CONTROL |
| 297 | | internal | |
| 296 | PC11 | IN/OUT | INPUT |
| 295 | | | OUTPUT |
| 294 | | | CONTROL |
| 293 | | internal | |
| 292 | PC12 | IN/OUT | INPUT |
| 291 | | | OUTPUT |
| 290 | | | CONTROL |
| 289 | | internal | |

Table 11-3. SAM9261 JTAG Boundary Scan Register (Continued)

| Bit Number | Pin Name | Pin Type | Associated BSR Cells |
|------------|----------|----------|----------------------|
| 288 | PC13 | IN/OUT | INPUT |
| 287 | | | OUTPUT |
| 286 | | | CONTROL |
| 285 | | internal | |
| 284 | PC14 | IN/OUT | INPUT |
| 283 | | | OUTPUT |
| 282 | | | CONTROL |
| 281 | | internal | |
| 280 | PC15 | IN/OUT | INPUT |
| 279 | | | OUTPUT |
| 278 | | | CONTROL |
| 277 | | internal | |
| 276 | PA0 | IN/OUT | INPUT |
| 275 | | | OUTPUT |
| 274 | | | CONTROL |
| 273 | | internal | |
| 272 | PA1 | IN/OUT | INPUT |
| 271 | | | OUTPUT |
| 270 | | | CONTROL |
| 269 | | internal | |
| 268 | PA2 | IN/OUT | INPUT |
| 267 | | | OUTPUT |
| 266 | | | CONTROL |
| 265 | | internal | |
| 264 | PA3 | IN/OUT | INPUT |
| 263 | | | OUTPUT |
| 262 | | | CONTROL |
| 261 | | internal | |
| 260 | PA4 | IN/OUT | INPUT |
| 259 | | | OUTPUT |
| 258 | | | CONTROL |
| 257 | | internal | |
| 256 | PA5 | IN/OUT | INPUT |
| 255 | | | OUTPUT |
| 254 | | | CONTROL |
| 253 | | internal | |

Table 11-3. SAM9261 JTAG Boundary Scan Register (Continued)

| Bit Number | Pin Name | Pin Type | Associated BSR Cells |
|------------|----------|----------|----------------------|
| 252 | PA6 | IN/OUT | INPUT |
| 251 | | | OUTPUT |
| 250 | | | CONTROL |
| 249 | | internal | |
| 248 | PA7 | IN/OUT | INPUT |
| 247 | | | OUTPUT |
| 246 | | | CONTROL |
| 245 | | internal | |
| 244 | PA8 | IN/OUT | INPUT |
| 243 | | | OUTPUT |
| 242 | | | CONTROL |
| 241 | | internal | |
| 240 | PA9 | IN/OUT | INPUT |
| 239 | | | OUTPUT |
| 238 | | | CONTROL |
| 237 | | internal | |
| 236 | PA10 | IN/OUT | INPUT |
| 235 | | | OUTPUT |
| 234 | | | CONTROL |
| 233 | | internal | |
| 232 | PA11 | IN/OUT | INPUT |
| 231 | | | OUTPUT |
| 230 | | | CONTROL |
| 229 | | internal | |
| 228 | PA12 | IN/OUT | INPUT |
| 227 | | | OUTPUT |
| 226 | | | CONTROL |
| 225 | | internal | |
| 224 | PA13 | IN/OUT | INPUT |
| 223 | | | OUTPUT |
| 222 | | | CONTROL |
| 221 | | internal | |
| 220 | PA14 | IN/OUT | INPUT |
| 219 | | | OUTPUT |
| 218 | | | CONTROL |
| 217 | | internal | |

Table 11-3. SAM9261 JTAG Boundary Scan Register (Continued)

| Bit Number | Pin Name | Pin Type | Associated BSR Cells |
|------------|----------|----------|----------------------|
| 216 | PA15 | IN/OUT | INPUT |
| 215 | | | OUTPUT |
| 214 | | | CONTROL |
| 213 | | internal | |
| 212 | PA16 | IN/OUT | INPUT |
| 211 | | | OUTPUT |
| 210 | | | CONTROL |
| 209 | | internal | |
| 208 | PA17 | IN/OUT | INPUT |
| 207 | | | OUTPUT |
| 206 | | | CONTROL |
| 205 | | internal | |
| 204 | PA18 | IN/OUT | INPUT |
| 203 | | | OUTPUT |
| 202 | | | CONTROL |
| 201 | | internal | |
| 200 | PA19 | IN/OUT | INPUT |
| 199 | | | OUTPUT |
| 198 | | | CONTROL |
| 197 | | internal | |
| 196 | PA20 | IN/OUT | INPUT |
| 195 | | | OUTPUT |
| 194 | | | CONTROL |
| 193 | | internal | |
| 192 | PA21 | IN/OUT | INPUT |
| 191 | | | OUTPUT |
| 190 | | | CONTROL |
| 189 | | internal | |
| 188 | PA22 | IN/OUT | INPUT |
| 187 | | | OUTPUT |
| 186 | | | CONTROL |
| 185 | | internal | |
| 184 | PA23 | IN/OUT | INPUT |
| 183 | | | OUTPUT |
| 182 | | | CONTROL |
| 181 | | internal | |

Table 11-3. SAM9261 JTAG Boundary Scan Register (Continued)

| Bit Number | Pin Name | Pin Type | Associated BSR Cells |
|------------|----------|----------|----------------------|
| 180 | PA24 | IN/OUT | INPUT |
| 179 | | | OUTPUT |
| 178 | | | CONTROL |
| 177 | | internal | |
| 176 | PA25 | IN/OUT | INPUT |
| 175 | | | OUTPUT |
| 174 | | | CONTROL |
| 173 | | internal | |
| 172 | PA26 | IN/OUT | INPUT |
| 171 | | | OUTPUT |
| 170 | | | CONTROL |
| 169 | | internal | |
| 168 | PA27 | IN/OUT | INPUT |
| 167 | | | OUTPUT |
| 166 | | | CONTROL |
| 165 | | internal | |
| 164 | PA28 | IN/OUT | INPUT |
| 163 | | | OUTPUT |
| 162 | | | CONTROL |
| 161 | | internal | |
| 160 | PA29 | IN/OUT | INPUT |
| 159 | | | OUTPUT |
| 158 | | | CONTROL |
| 157 | | internal | |
| 156 | PA30 | IN/OUT | INPUT |
| 155 | | | OUTPUT |
| 154 | | | CONTROL |
| 153 | | internal | |
| 152 | PA31 | IN/OUT | INPUT |
| 151 | | | OUTPUT |
| 150 | | | CONTROL |
| 149 | | internal | |
| 148 | PB0 | IN/OUT | INPUT |
| 147 | | | OUTPUT |
| 146 | | | CONTROL |
| 145 | | internal | |

Table 11-3. SAM9261 JTAG Boundary Scan Register (Continued)

| Bit Number | Pin Name | Pin Type | Associated BSR Cells |
|------------|----------|----------|----------------------|
| 144 | PB1 | IN/OUT | INPUT |
| 143 | | | OUTPUT |
| 142 | | | CONTROL |
| 141 | | internal | |
| 140 | PB2 | IN/OUT | INPUT |
| 139 | | | OUTPUT |
| 138 | | | CONTROL |
| 137 | | internal | |
| 136 | PB3 | IN/OUT | INPUT |
| 135 | | | OUTPUT |
| 134 | | | CONTROL |
| 133 | | internal | |
| 132 | PB4 | IN/OUT | INPUT |
| 131 | | | OUTPUT |
| 130 | | | CONTROL |
| 129 | | internal | |
| 128 | PB5 | IN/OUT | INPUT |
| 127 | | | OUTPUT |
| 126 | | | CONTROL |
| 125 | | internal | |
| 124 | PB6 | IN/OUT | INPUT |
| 123 | | | OUTPUT |
| 122 | | | CONTROL |
| 121 | | internal | |
| 120 | PB7 | IN/OUT | INPUT |
| 119 | | | OUTPUT |
| 118 | | | CONTROL |
| 117 | | internal | |
| 116 | PB8 | IN/OUT | INPUT |
| 115 | | | OUTPUT |
| 114 | | | CONTROL |
| 113 | | internal | |
| 112 | PB9 | IN/OUT | INPUT |
| 111 | | | OUTPUT |
| 110 | | | CONTROL |
| 109 | | internal | |

Table 11-3. SAM9261 JTAG Boundary Scan Register (Continued)

| Bit Number | Pin Name | Pin Type | Associated BSR Cells |
|------------|----------|----------|----------------------|
| 108 | PB10 | IN/OUT | INPUT |
| 107 | | | OUTPUT |
| 106 | | | CONTROL |
| 105 | | internal | |
| 104 | PB11 | IN/OUT | INPUT |
| 103 | | | OUTPUT |
| 102 | | | CONTROL |
| 101 | | internal | |
| 100 | PB12 | IN/OUT | INPUT |
| 99 | | | OUTPUT |
| 98 | | | CONTROL |
| 97 | | internal | |
| 96 | PB13 | IN/OUT | INPUT |
| 95 | | | OUTPUT |
| 94 | | | CONTROL |
| 93 | | internal | |
| 92 | PB14 | IN/OUT | INPUT |
| 91 | | | OUTPUT |
| 90 | | | CONTROL |
| 89 | | internal | |
| 88 | PB15 | IN/OUT | INPUT |
| 87 | | | OUTPUT |
| 86 | | | CONTROL |
| 85 | | internal | |
| 84 | PB16 | IN/OUT | INPUT |
| 83 | | | OUTPUT |
| 82 | | | CONTROL |
| 81 | | internal | |
| 80 | PB17 | IN/OUT | INPUT |
| 79 | | | OUTPUT |
| 78 | | | CONTROL |
| 77 | | internal | |
| 76 | PB18 | IN/OUT | INPUT |
| 75 | | | OUTPUT |
| 74 | | | CONTROL |
| 73 | | internal | |

Table 11-3. SAM9261 JTAG Boundary Scan Register (Continued)

| Bit Number | Pin Name | Pin Type | Associated BSR Cells |
|------------|----------|----------|----------------------|
| 72 | PB19 | IN/OUT | INPUT |
| 71 | | | OUTPUT |
| 70 | | | CONTROL |
| 69 | | internal | |
| 68 | PB20 | IN/OUT | INPUT |
| 67 | | | OUTPUT |
| 66 | | | CONTROL |
| 65 | | internal | |
| 64 | PB21 | IN/OUT | INPUT |
| 63 | | | OUTPUT |
| 62 | | | CONTROL |
| 61 | | internal | |
| 60 | PB22 | IN/OUT | INPUT |
| 59 | | | OUTPUT |
| 58 | | | CONTROL |
| 57 | | internal | |
| 56 | PB23 | IN/OUT | INPUT |
| 55 | | | OUTPUT |
| 54 | | | CONTROL |
| 53 | | internal | |
| 52 | PB24 | IN/OUT | INPUT |
| 51 | | | OUTPUT |
| 50 | | | CONTROL |
| 49 | | internal | |
| 48 | PB25 | IN/OUT | INPUT |
| 47 | | | OUTPUT |
| 46 | | | CONTROL |
| 45 | | internal | |
| 44 | PB26 | IN/OUT | INPUT |
| 43 | | | OUTPUT |
| 42 | | | CONTROL |
| 41 | | internal | |
| 40 | PB27 | IN/OUT | INPUT |
| 39 | | | OUTPUT |
| 38 | | | CONTROL |
| 37 | | internal | |

Table 11-3. SAM9261 JTAG Boundary Scan Register (Continued)

| Bit Number | Pin Name | Pin Type | Associated BSR Cells |
|------------|----------|----------|----------------------|
| 36 | PB28 | IN/OUT | INPUT |
| 35 | | | OUTPUT |
| 34 | | | CONTROL |
| 33 | | internal | |
| 32 | PB29 | IN/OUT | INPUT |
| 31 | | | OUTPUT |
| 30 | | | CONTROL |
| 29 | | internal | |
| 28 | PB30 | IN/OUT | INPUT |
| 27 | | | OUTPUT |
| 26 | | | CONTROL |
| 25 | | internal | |
| 24 | PB31 | IN/OUT | INPUT |
| 23 | | | OUTPUT |
| 22 | | | CONTROL |
| 21 | | internal | |
| 20 | A0 | OUT | OUTPUT |
| 19 | | internal | |
| 18 | A1 | OUT | OUTPUT |
| 17 | A2 | OUT | OUTPUT |
| 16 | A3 | OUT | OUTPUT |
| 15 | A4 | OUT | OUTPUT |
| 14 | A5 | OUT | OUTPUT |
| 13 | A6 | OUT | OUTPUT |
| 12 | A7 | OUT | OUTPUT |
| 11 | A8 | OUT | OUTPUT |
| 10 | A[15:8] | | CONTROL |
| 09 | A9 | OUT | OUTPUT |
| 08 | A10 | OUT | OUTPUT |
| 07 | SDA10 | OUT | OUTPUT |
| 06 | A11 | OUT | OUTPUT |
| 05 | A12 | OUT | OUTPUT |
| 04 | A13 | OUT | OUTPUT |
| 03 | A14 | OUT | OUTPUT |
| 02 | A15 | OUT | OUTPUT |
| 01 | A16 | OUT | OUTPUT |
| 00 | A17 | OUT | OUTPUT |

11.5.7 ID Code Register

Access: Read-only

| | | | | | | | |
|-----------------------|----|----|----|-----------------------|----|----|----|
| 31 | 30 | 29 | 28 | 27 | 26 | 25 | 24 |
| VERSION | | | | PART NUMBER | | | |
| 23 | 22 | 21 | 20 | 19 | 18 | 17 | 16 |
| PART NUMBER | | | | | | | |
| 15 | 14 | 13 | 12 | 11 | 10 | 9 | 8 |
| PART NUMBER | | | | MANUFACTURER IDENTITY | | | |
| 7 | 6 | 5 | 4 | 3 | 2 | 1 | 0 |
| MANUFACTURER IDENTITY | | | | | | | 1 |

- **VERSION[31:28]: Product Version Number**

Set to 0x0.

- **PART NUMBER[27:12]: Product Part Number**

Product part Number is 0x5B08

- **MANUFACTURER IDENTITY[11:1]**

Set to 0x01F.

Bit[0] Required by IEEE Std. 1149.1.

Set to 0x1.

JTAG ID Code value is 0x05B0_803F.

12. Boot Program

12.1 Description

The boot program integrates different programs that manage download and/or upload into the different memories of the product.

First, it initializes the Debug Unit serial port (DBGU) and the USB High Speed Device Port.

The boot program tries to detect SPI flash memories. The Serial Flash boot program and DataFlash boot program are executed. It looks for a sequence of seven valid ARM exception vectors in a Serial Flash or DataFlash connected to the SPI. All these vectors must be B-branch or LDR load register instructions except for the sixth vector. This vector is used to store the size of the image to download.

If a valid sequence is found, code is downloaded into the internal SRAM. This is followed by a remap and a jump to the first address of the SRAM.

If no valid ARM vector sequence is found, NAND Flash boot program is then executed. The NAND Flash boot program looks for a sequence of seven valid ARM exception vectors. If such a sequence is found, code is downloaded into the internal SRAM. This is followed by a remap and a jump to the first address of the SRAM.

Then the SD Card boot program is executed. It looks for a boot.bin file in the root directory of a FAT12/16/32 formatted SD Card on Slot A. If such a file is found, code is downloaded into the internal SRAM. This is followed by a remap and a jump to the first address of the SRAM.

If the SD Card is not formatted or if boot.bin file is not found, TWI boot program is then executed. The TWI boot program searches for a valid application in a EEPROM memory. If such a file is found, code is downloaded into the internal SRAM. This is followed by a remap and a jump to the first address of the SRAM.

If no valid ARM vector sequence is found, SAM-BA Boot is then executed. It waits for transactions either on the USB device, or on the DBGU serial port.

12.2 Flow Diagram

The Boot Program implements the algorithm in [Figure 12-1](#).

Figure 12-1. Boot Program Algorithm Flow Diagram

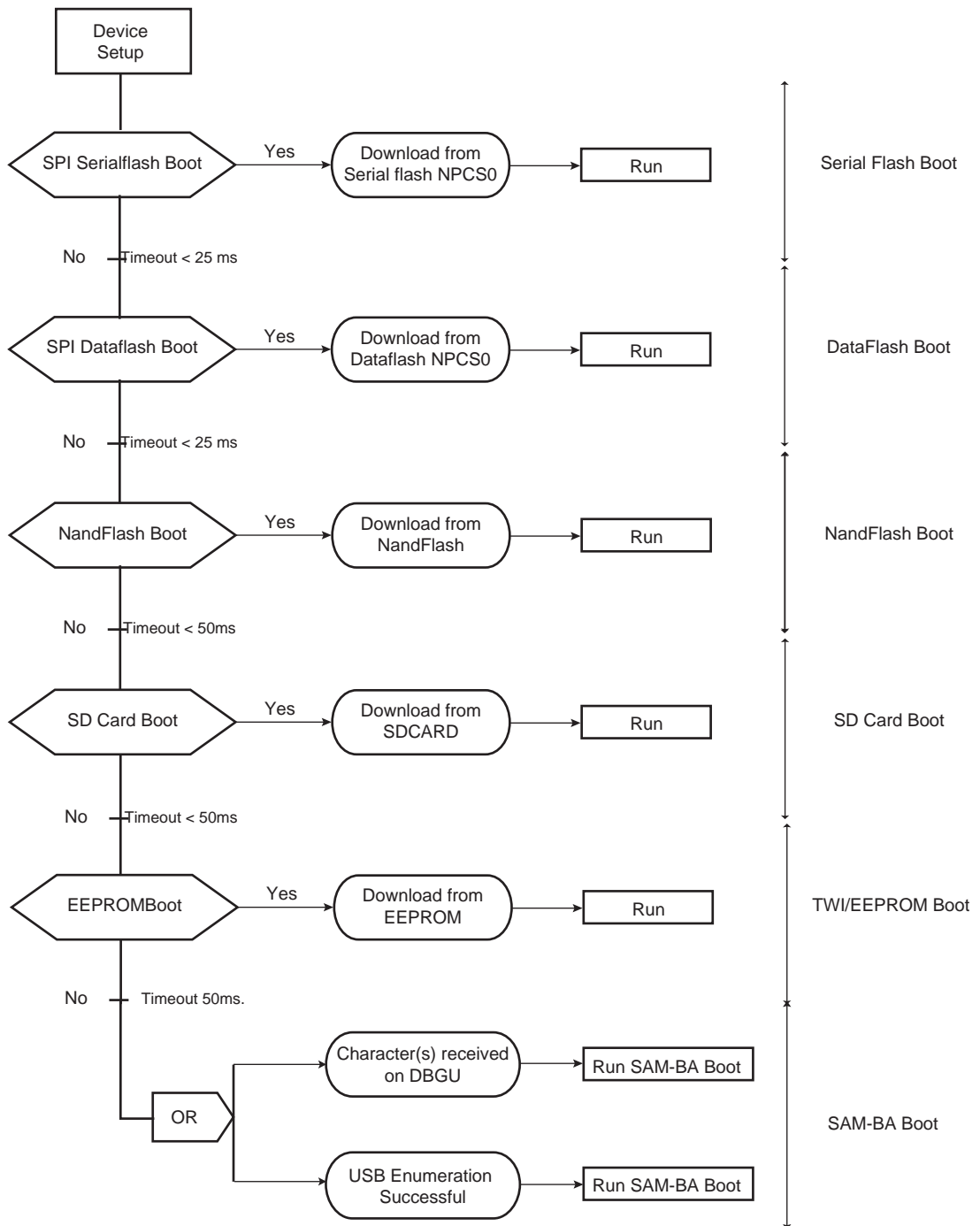

12.3 Device Initialization

Initialization follows the steps described below:

1. Stack setup for ARM supervisor mode
2. Main Oscillator Frequency Detection
3. C variable initialization
4. PLL setup: PLLB is initialized to generate a 48 MHz clock necessary to use the USB Device. A register located in the Power Management Controller (PMC) determines the frequency of the main oscillator and thus the correct factor for the PLLB.

Table 12-1 defines the crystals supported by the boot program.

Table 12-1. Crystals Supported by Software Auto-Detection (MHz)

| | | | | |
|----------|----------|-----------|--------|----------|
| 3.0 | 3.2768 | 3.6864 | 3.84 | 4.0 |
| 4.433619 | 4.608 | 4.9152 | 5.0 | 5.24288 |
| 6.0 | 6.144 | 6.4 | 6.5536 | 7.159090 |
| 7.3728 | 7.864320 | 8.0 | 9.8304 | 10.0 |
| 11.05920 | 12.0 | 12.288 | 13.56 | 14.31818 |
| 14.7456 | 16.0 | 17.734470 | 18.432 | 20.0 |

5. Initialization of the DBGU serial port (115200 bauds, 8, N, 1)
6. Enable the user reset
7. Jump to Serial Flash Boot sequence through NPCS0. If Serial Flash Boot succeeds, perform a remap and jump to 0x0.
8. Jump to DataFlash Boot sequence through NPCS0. If DataFlash Boot succeeds, perform a remap and jump to 0x0.
9. Jump to NAND Flash Boot sequence. If NAND Flash Boot succeeds, perform a remap and jump to 0x0.
10. Jump to SD Card Boot sequence. If SD Card Boot succeeds, perform a remap and jump to 0x0.
11. Jump to EEPROM Boot sequence. If EEPROM Boot succeeds, perform a remap and jump to 0x0.
12. Activation of the Instruction Cache
13. Jump to SAM-BA Boot sequence
14. Disable the WatchDog
15. Initialization of the USB Device Port

Figure 12-2. Remap Action after Download Completion

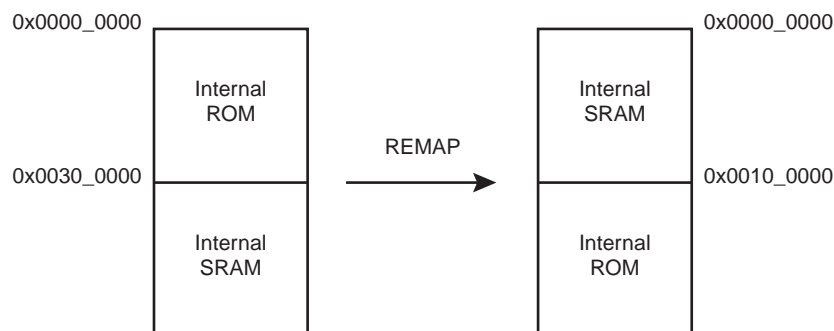

12.4 Valid Image Detection

The boot software looks for a valid application by analyzing the first 28 bytes corresponding to the ARM exception vectors. These bytes must implement ARM instructions for either branch or load PC with PC relative addressing.

The sixth vector, at offset 0x14, contains the size of the image to download. The user must replace this vector with his own vector (see [Section 12.4.2 “Structure of ARM Vector 6”](#)).

12.4.1 Valid ARM Exception Vectors

Figure 12-3. LDR Opcode

| | | | | | | | | | | | |
|----|----|----|----|----|----|----|----|----|----|----|---|
| 31 | 28 | 27 | 24 | 23 | 20 | 19 | 16 | 15 | 12 | 11 | 0 |
| 1 | 1 | 1 | 0 | 0 | 1 | I | P | U | 0 | W | 1 |
| | | | | Rn | | | | Rd | | | |

Figure 12-4. B Opcode

| | | | | | |
|------------------|----|----|----|----|---|
| 31 | 28 | 27 | 24 | 23 | 0 |
| 1 | 1 | 1 | 0 | 1 | 0 |
| Offset (24 bits) | | | | | |

Unconditional instruction: 0xE for bits 31 to 28

Load PC with PC relative addressing instruction:

- Rn = Rd = PC = 0xF
- I==0
- P==1
- U offset added (U==1) or subtracted (U==0)
- W==1

12.4.2 Structure of ARM Vector 6

The ARM exception vector 6 is used to store information needed by the boot program. This information is described below.

Figure 12-5. Structure of the ARM Vector 6

| | |
|---------------------------------------|---|
| 31 | 0 |
| Size of the code to download in bytes | |

12.4.2.1 Example

An example of valid vectors follows:

| Address | Value | Code |
|---------|-----------|---|
| 00 | ea000006 | B 0x20 |
| 04 | eaffffffe | B 0x04 |
| 08 | ea00002f | B _main |
| 0c | eaffffffe | B 0x0c |
| 10 | eaffffffe | B 0x10 |
| 14 | 00001000 | Code size = 4096 bytes (less than or equal to 156 Kbytes) |
| 18 | eaffffffe | B 0x18 |

The size of the image to load into SRAM is contained in the location of the sixth ARM vector. Thus the user must replace this vector by the correct size of his application.

12.5 Serial Flash Boot

The Serial Flash boot looks for a valid application in the SPI Serial Flash memory.

SPI0 is configured in master mode to generate a SPCK at 8 MHz. Serial Flash shall be connected to NPCS0.

The Serial Flash boot reads the serial flash status register (Instruction code 0x05). The serial flash is considered as ready if bit 0 of the returned status register is cleared.

If no serial flash is connected or if it does not answer, Serial Flash boots exits after a 1000 attempts.

If the serial flash is ready, Serial Flash boot reads the first 8 words into SRAM (Instruction code “Continuous read array” 0x0b) and checks if it corresponds to valid exception vectors according to the Valid Image detection algorithm.

If a valid application is found, this application is loaded into internal SRAM and executed by branching at address 0x0000_0000 after remap. This application may be the application code or a second-level bootloader.

Figure 12-6. Serial Flash Download

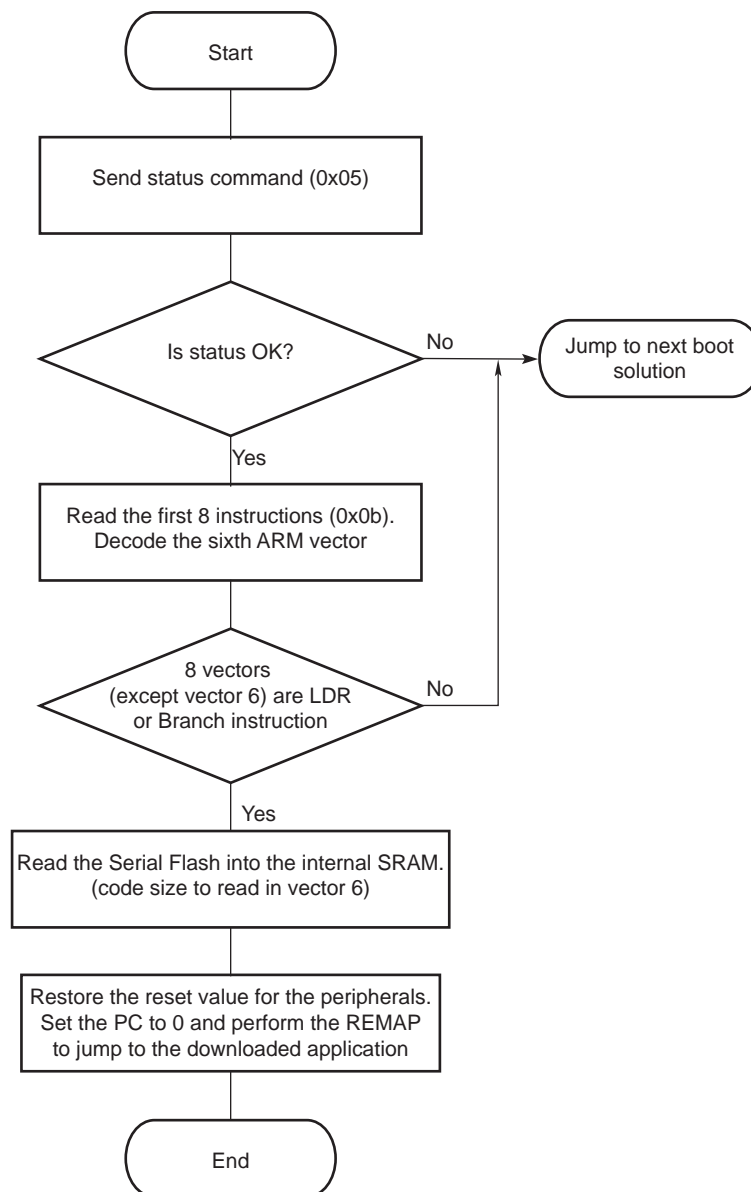

12.6 DataFlash Boot Sequence

The DataFlash boot looks for a valid application in the SPI DataFlash memory.

SPI0 is configured in master mode to generate a SPCK at 8 MHz. Serial Flash shall be connected to NPCS0.

The DataFlash boot reads the DataFlash flash status register (Instruction code 0xD7). The DataFlash is considered as ready if bit 7 of the returned status register is set.

If no DataFlash is connected or if it does not answer, DataFlash boot exits after 1000 attempts.

If the DataFlash is ready, DataFlash boot reads the first 8 words into SRAM (Instruction code "Continuous Read Array" 0x0b) and checks if it corresponds to valid exception vectors according to the Valid Image detection algorithm.

If a valid application is found, this application is loaded into internal SRAM and executed by branching at address 0x0000_0000 after remap. This application may be the application code or a second-level bootloader.

The DataFlash boot is configured to be compatible with the future design of the DataFlash.

Figure 12-7. DataFlash Download

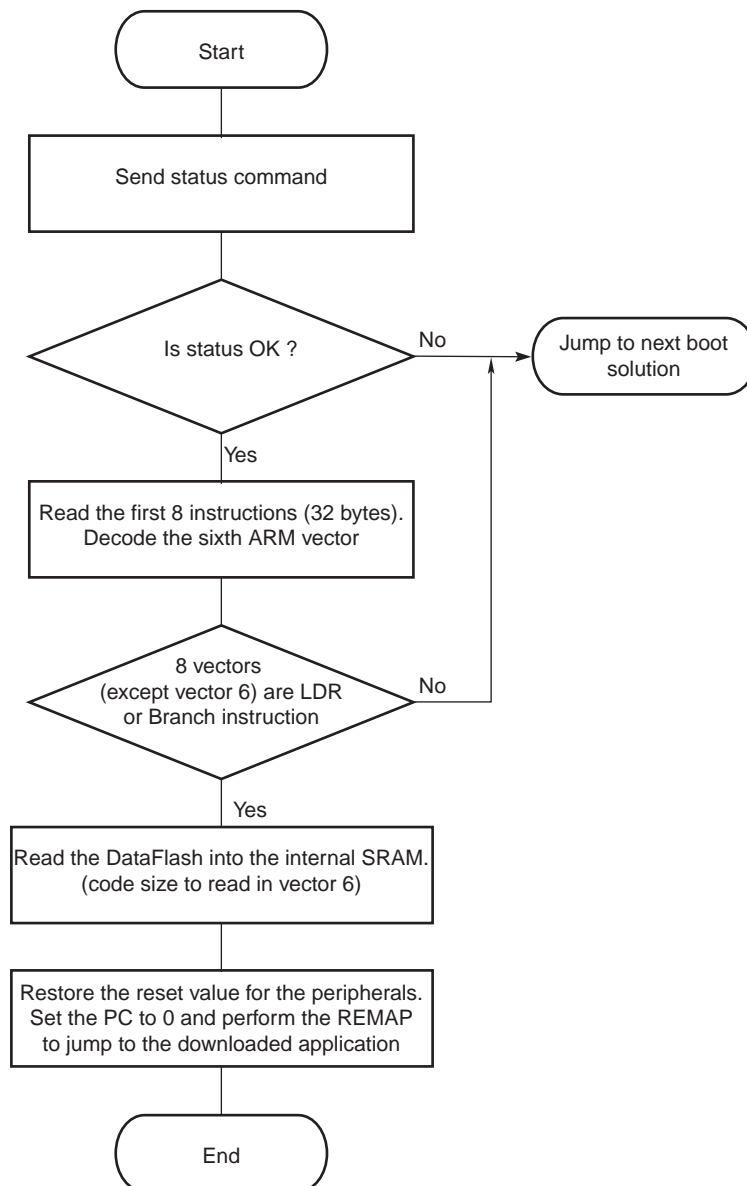

12.7 NAND Flash Boot

The NAND Flash Boot program searches for a valid application in the NAND Flash memory. The first block must be guaranteed by the manufacturer. There is no ECC check.

If a valid application is found, this application is loaded into internal SRAM and executed by branching at address 0x0000_0000 after remap. See [“Valid Image Detection” on page 79](#) for more information on Valid Image Detection.

12.7.1 Supported NAND Flash Devices

Any 8 or 16-bit NAND Flash devices.

12.8 SD Card Boot

The SD Card boot program searches for a valid application in the SD Card memory.

(Boot ROM does not support high capacity SDCards.)

It looks for a boot.bin file in the root directory of a FAT12/16/32 formatted SD Card. If a valid file is found, this application is loaded into internal SRAM and executed by branching at address 0x0000_0000 after remap. This application may be the application code or a second-level bootloader.

12.9 EEPROM Boot

The EEPROM boot program searches for a valid application in an EEPROM connected to the TWI address: 0x0050_0000.

If a valid application is found, this application is loaded into internal SRAM and executed by branching at address 0x0000_0000 after remap. See [“Valid Image Detection” on page 79](#) for more information on Valid Image Detection.

12.10 SAM-BA Boot

If no valid DataFlash device has been found during the DataFlash boot sequence, the SAM-BA boot program is performed.

The SAM-BA boot principle is to:

- Wait for USB Device enumeration.
- In parallel, wait for character(s) received on the DBGU
- Once the communication interface is identified, the application runs in an infinite loop waiting for different commands as in [Table 12-2](#).

Table 12-2. Commands Available through the SAM-BA Boot

| Command | Action | Argument(s) | Example |
|---------|-------------------|---------------------|--------------------------|
| O | write a byte | Address, Value# | O 200001,CA# |
| o | read a byte | Address,# | o 200001,# |
| H | write a half word | Address, Value# | H 200002,CAFE# |
| h | read a half word | Address,# | h 200002,# |
| W | write a word | Address, Value# | W 200000,CAFEDCA# |
| w | read a word | Address,# | w 200000,# |
| S | send a file | Address,# | S 200000,# |
| R | receive a file | Address, NbOfBytes# | R 200000,1234# |
| G | go | Address# | G 200200# |
| V | display version | No argument | V # |

- Write commands: Write a byte (**O**), a halfword (**H**) or a word (**W**) to the target.
 - *Address*: Address in hexadecimal.
 - *Value*: Byte, halfword or word to write in hexadecimal.
 - *Output*: '>'.
- Read commands: Read a byte (**o**), a halfword (**h**) or a word (**w**) from the target.
 - *Address*: Address in hexadecimal
 - *Output*: The byte, halfword or word read in hexadecimal following by '>'
- Send a file (**S**): Send a file to a specified address
 - *Address*: Address in hexadecimal
 - *Output*: '>'.

Note: There is a time-out on this command which is reached when the prompt '>' appears before the end of the command execution.

- Receive a file (**R**): Receive data into a file from a specified address
 - *Address*: Address in hexadecimal
 - *NbOfBytes*: Number of bytes in hexadecimal to receive
 - *Output*: '>'
- Go (**G**): Jump to a specified address and execute the code
 - *Address*: Address to jump in hexadecimal
 - *Output*: '>'
- Get Version (**V**): Return the SAM-BA boot version
 - *Output*: '>'

12.10.1 DBGU Serial Port

Communication is performed through the DBGU serial port initialized to 115200 Baud, 8, n, 1.

The Send and Receive File commands use the Xmodem protocol to communicate. Any terminal performing this protocol can be used to send the application file to the target. The size of the binary file to send depends on the SRAM size embedded in the product. In all cases, the size of the binary file must be lower than the SRAM size because the Xmodem protocol requires some SRAM memory to work.

12.10.2 Xmodem Protocol

The Xmodem protocol supported is the 128-byte length block. This protocol uses a two-character CRC-16 to guarantee detection of a maximum bit error.

Xmodem protocol with CRC is accurate provided both sender and receiver report successful transmission. Each block of the transfer looks like:

<SOH><blk #><255-blk #><--128 data bytes--><checksum> in which:

- <SOH> = 01 hex
- <blk #> = binary number, starts at 01, increments by 1, and wraps 0FFH to 00H (not to 01)
- <255-blk #> = 1's complement of the blk#.
- <checksum> = 2 bytes CRC16

Figure 12-8 shows a transmission using this protocol.

Figure 12-8. Xmodem Transfer Example

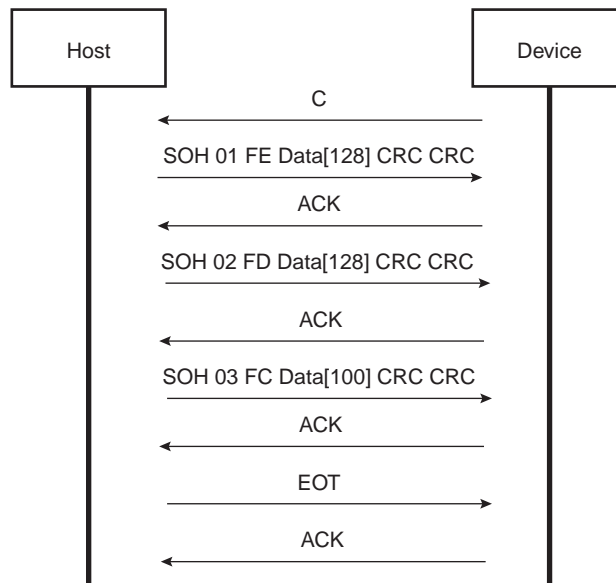

12.10.3 USB Device Port

A 48 MHz USB clock is necessary to use the USB Device port. It has been programmed earlier in the device initialization procedure with PLLB configuration.

The device uses the USB communication device class (CDC) drivers to take advantage of the installed PC RS-232 software to talk over the USB. The CDC class is implemented in all releases of Windows®, beginning with Windows 98SE. The CDC document, available at www.usb.org, describes a way to implement devices such as ISDN modems and virtual COM ports.

The Vendor ID is Atmel's vendor ID 0x03EB. The product ID is 0x6124. These references are used by the host operating system to mount the correct driver. On Windows systems, the INF files contain the correspondence between vendor ID and product ID.

Atmel provides an INF example to see the device as a new serial port and also provides another custom driver used by the SAM-BA application: atm6124.sys. Refer to the document *USB Basic Application*, literature number 6123, for more details.

12.10.3.1 Enumeration Process

The USB protocol is a master/slave protocol. This is the host that starts the enumeration sending requests to the device through the control endpoint. The device handles standard requests as defined in the USB Specification.

Table 12-3. Handled Standard Requests

| Request | Definition |
|-------------------|---|
| GET_DESCRIPTOR | Returns the current device configuration value. |
| SET_ADDRESS | Sets the device address for all future device access. |
| SET_CONFIGURATION | Sets the device configuration. |
| GET_CONFIGURATION | Returns the current device configuration value. |
| GET_STATUS | Returns status for the specified recipient. |
| SET_FEATURE | Used to set or enable a specific feature. |
| CLEAR_FEATURE | Used to clear or disable a specific feature. |

The device also handles some class requests defined in the CDC class.

Table 12-4. Handled Class Requests

| Request | Definition |
|------------------------|--|
| SET_LINE_CODING | Configures DTE rate, stop bits, parity and number of character bits. |
| GET_LINE_CODING | Requests current DTE rate, stop bits, parity and number of character bits. |
| SET_CONTROL_LINE_STATE | RS-232 signal used to tell the DCE device the DTE device is now present. |

Unhandled requests are STALLED.

12.10.3.2 Communication Endpoints

There are two communication endpoints and endpoint 0 is used for the enumeration process. Endpoint 1 is a 64-byte Bulk OUT endpoint and endpoint 2 is a 64-byte Bulk IN endpoint. SAM-BA Boot commands are sent by the host through the endpoint 1. If required, the message is split by the host into several data payloads by the host driver.

If the command requires a response, the host can send IN transactions to pick up the response.

12.11 Hardware and Software Constraints

- The DataFlash, Serial Flash, NAND Flash, SDCard⁽¹⁾, and EEPROM downloaded code size is limited to 156 Kbytes.
- The code is always downloaded from the device address 0x0000_0000 to the address 0x0000_0000 of the internal SRAM (after remap).
- The downloaded code must be position-independent or linked at address 0x0000_0000.
- The DataFlash must be connected to NPCS0 of the SPI.

Note: 1. Boot ROM does not support high capacity SDCards.

The SPI and NAND Flash drivers use several PIOs in alternate functions to communicate with devices. Care must be taken when these PIOs are used by the application. The devices connected could be unintentionally driven at boot time, and electrical conflicts between SPI output pins and the connected devices may appear.

To assure correct functionality, it is recommended to plug in critical devices to other pins.

Table 12-5 contains a list of pins that are driven during the boot program execution. These pins are driven during the boot sequence for a period of less than 1 second if no correct boot program is found.

Before performing the jump to the application in internal SRAM, all the PIOs and peripherals used in the boot program are set to their reset state.

Table 12-5. Pins Driven During Boot Program Execution

| Peripheral | Pin | PIO Line |
|-------------|----------|----------|
| SPI0 | MOSI | PIOA1 |
| SPI0 | MISO | PIOA0 |
| SPI0 | SPCK | PIOA2 |
| SPI0 | NPCS0 | PIOA3 |
| PIOC | NANDCS | PIOC14 |
| PIOC | NAND OE | PIOC0 |
| PIOC | NAND WE | PIOC1 |
| Address Bus | NAND CLE | A21 |
| Address Bus | NAND ALE | A22 |
| MCI0 | MCDA0 | PIOA0 |
| MCI0 | MCCDA | PIOA1 |
| MCI0 | MCCK | PIOA2 |
| MCI0 | MCDA1 | PIOA4 |
| MCI0 | MCDA2 | PIOA5 |
| MCI0 | MCDA3 | PIOA6 |
| TWI | TWCK | PIOA8 |
| TWI | TWD | PIOA7 |
| DBGU | DRXD | PIOA9 |
| DBGU | DTXD | PIOA10 |

13. Reset Controller (RSTC)

13.1 Overview

The Reset Controller (RSTC), based on power-on reset cells, handles all the resets of the system without any external components. It reports which reset occurred last.

The Reset Controller also drives independently or simultaneously the external reset and the peripheral and processor resets.

13.2 Embedded Characteristics

- Based on two Power-on-Reset cells
- Status of the last reset
 - Either cold reset, first reset, soft reset, user reset, watchdog reset, wakeup reset
- Controls the internal resets and the NRST pin output

13.3 Block Diagram

Figure 13-1. Reset Controller Block Diagram

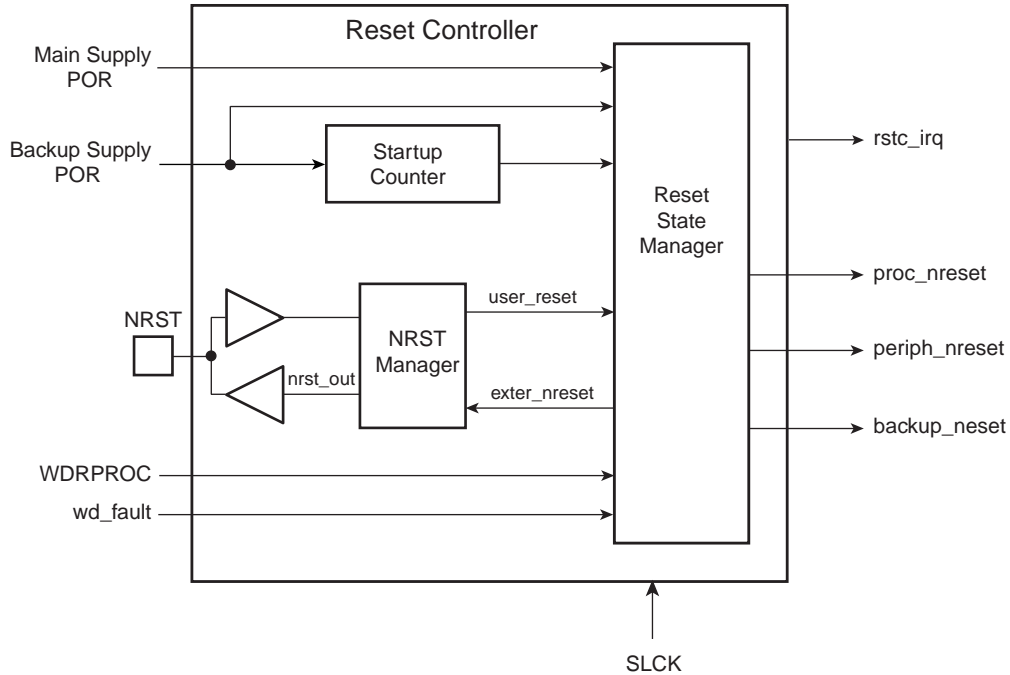

13.4 Functional Description

13.4.1 Reset Controller Overview

The Reset Controller is made up of an NRST Manager, a Startup Counter and a Reset State Manager. It runs at Slow Clock and generates the following reset signals:

- `proc_nreset`: Processor reset line. It also resets the Watchdog Timer.
- `backup_nreset`: Affects all the peripherals powered by VDDDBU.
- `periph_nreset`: Affects the whole set of embedded peripherals.
- `nrst_out`: Drives the NRST pin.

These reset signals are asserted by the Reset Controller, either on external events or on software action. The Reset State Manager controls the generation of reset signals and provides a signal to the NRST Manager when an assertion of the NRST pin is required.

The NRST Manager shapes the NRST assertion during a programmable time, thus controlling external device resets.

The startup counter waits for the complete crystal oscillator startup. The wait delay is given by the crystal oscillator startup time maximum value that can be found in the section Crystal Oscillator Characteristics in the Electrical Characteristics section of the product documentation.

The Reset Controller Mode Register (`RSTC_MR`), allowing the configuration of the Reset Controller, is powered with VDDDBU, so that its configuration is saved as long as VDDDBU is on.

13.4.2 NRST Manager

The NRST Manager samples the NRST input pin and drives this pin low when required by the Reset State Manager. Figure 13-2 shows the block diagram of the NRST Manager.

Figure 13-2. NRST Manager

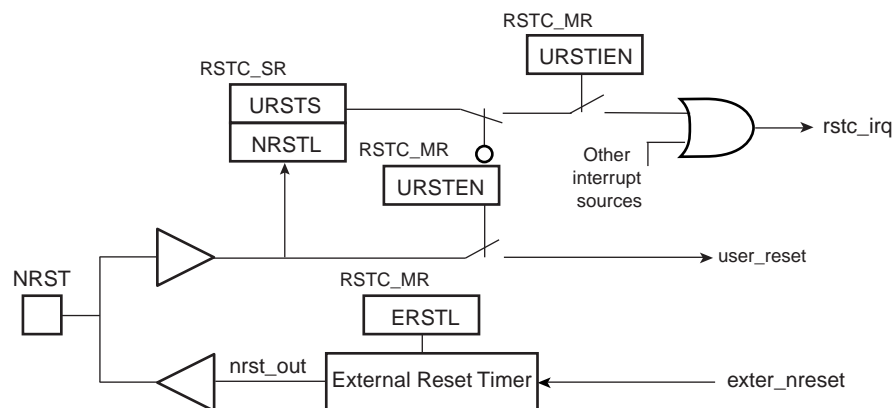

13.4.2.1 NRST Signal or Interrupt

The NRST Manager samples the NRST pin at Slow Clock speed. When the line is detected low, a User Reset is reported to the Reset State Manager.

However, the NRST Manager can be programmed to not trigger a reset when an assertion of NRST occurs. Writing the bit `URSTEN` at 0 in `RSTC_MR` disables the User Reset trigger.

The level of the pin NRST can be read at any time in the bit `NRSTL` (NRST level) in `RSTC_SR`. As soon as the pin NRST is asserted, the bit `URSTS` in `RSTC_SR` is set. This bit clears only when `RSTC_SR` is read.

The Reset Controller can also be programmed to generate an interrupt instead of generating a reset. To do so, the bit `URSTIEN` in `RSTC_MR` must be written at 1.

13.4.2.2 NRST External Reset Control

The Reset State Manager asserts the signal `ext_nreset` to assert the NRST pin. When this occurs, the “`nrst_out`” signal is driven low by the NRST Manager for a time programmed by the field `ERSTL` in `RSTC_MR`. This assertion duration, named `EXTERNAL_RESET_LENGTH`, lasts $2^{(ERSTL+1)}$ Slow Clock cycles. This gives the approximate duration of an assertion between 60 μ s and 2 seconds. Note that `ERSTL` at 0 defines a two-cycle duration for the NRST pulse.

This feature allows the Reset Controller to shape the NRST pin level, and thus to guarantee that the NRST line is driven low for a time compliant with potential external devices connected on the system reset.

As the field is within `RSTC_MR`, which is backed up, this field can be used to shape the system power-up reset for devices requiring a longer startup time than the Slow Clock Oscillator.

13.4.3 BMS Sampling

The product matrix manages a boot memory that depends on the level on the BMS pin at reset. The BMS signal is sampled three slow clock cycles after the Core Power-On-Reset output rising edge.

Figure 13-3. BMS Sampling

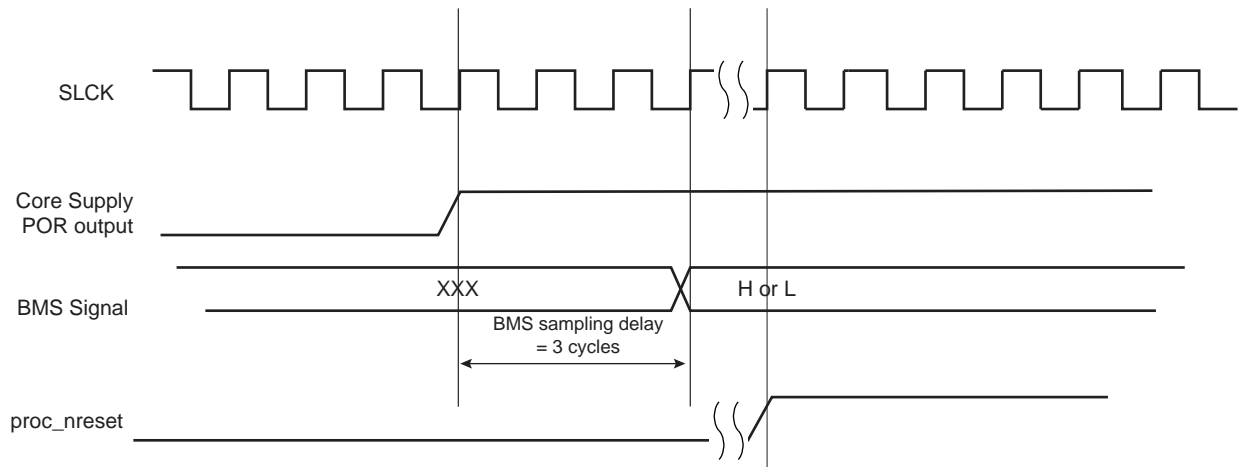

13.4.4 Reset States

The Reset State Manager handles the different reset sources and generates the internal reset signals. It reports the reset status in the field RSTTYP of the Status Register (RSTC_SR). The update of the field RSTTYP is performed when the processor reset is released.

13.4.4.1 General Reset

A general reset occurs when VDDDBU and VDDCORE are powered on. The backup supply POR cell output rises and is filtered with a Startup Counter, which operates at Slow Clock. The purpose of this counter is to make sure the Slow Clock oscillator is stable before starting up the device. The length of startup time is hardcoded to comply with the Slow Clock Oscillator startup time.

After this time, the processor clock is released at Slow Clock and all the other signals remain valid for 2 cycles for proper processor and logic reset. Then, all the reset signals are released and the field RSTTYP in RSTC_SR reports a General Reset. As the RSTC_MR is reset, the NRST line rises 2 cycles after the backup_nreset, as ERSTL defaults at value 0x0.

When VDDDBU is detected low by the Backup Supply POR Cell, all resets signals are immediately asserted, even if the Main Supply POR Cell does not report a Main Supply shutdown.

VDDDBU only activates the backup_nreset signal.

The backup_nreset must be released so that any other reset can be generated by VDDCORE (Main Supply POR output).

Figure 13-4 shows how the General Reset affects the reset signals.

Figure 13-4. General Reset State

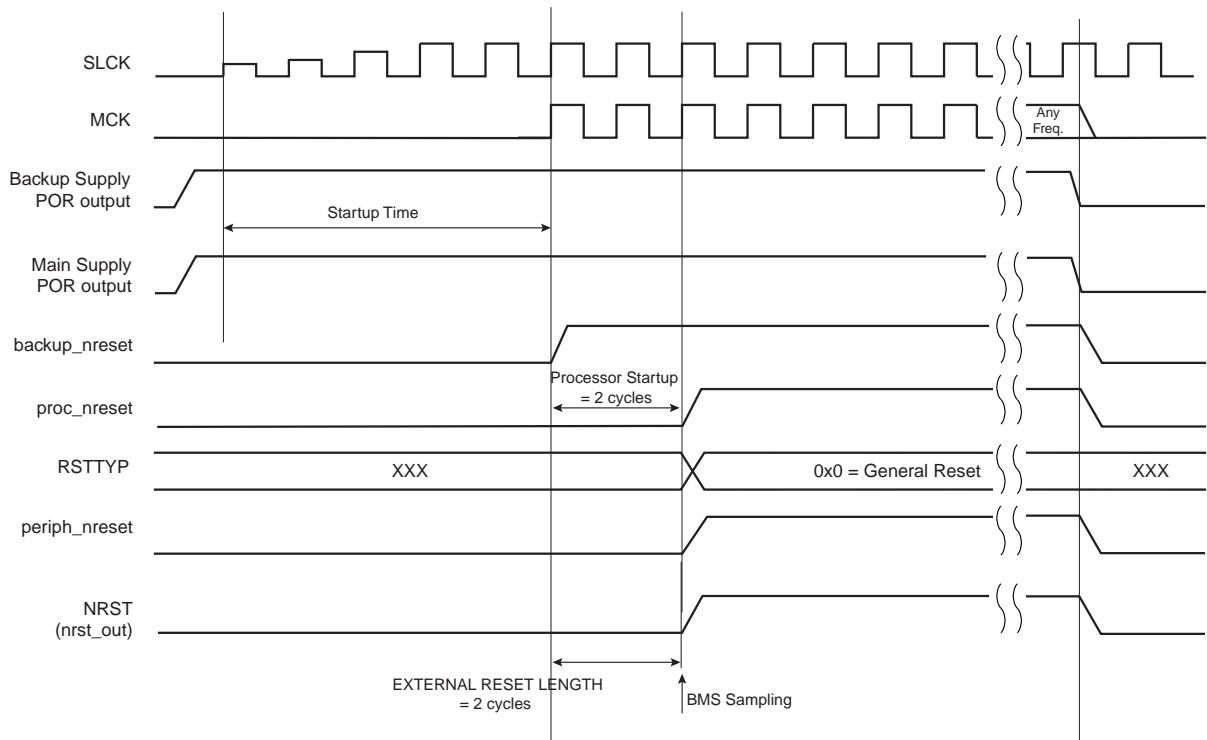

13.4.4.2 Wakeup Reset

The Wakeup Reset occurs when the Main Supply is down. When the Main Supply POR output is active, all the reset signals are asserted except backup_nreset. When the Main Supply powers up, the POR output is resynchronized on Slow Clock. The processor clock is then re-enabled during 2 Slow Clock cycles, depending on the requirements of the ARM processor.

At the end of this delay, the processor and other reset signals rise. The field RSTTYP in RSTC_SR is updated to report a Wakeup Reset.

The “nrst_out” remains asserted for EXTERNAL_RESET_LENGTH cycles. As RSTC_MR is backed up, the programmed number of cycles is applicable.

When the Main Supply is detected falling, the reset signals are immediately asserted. This transition is synchronous with the output of the Main Supply POR.

Figure 13-5. Wakeup State

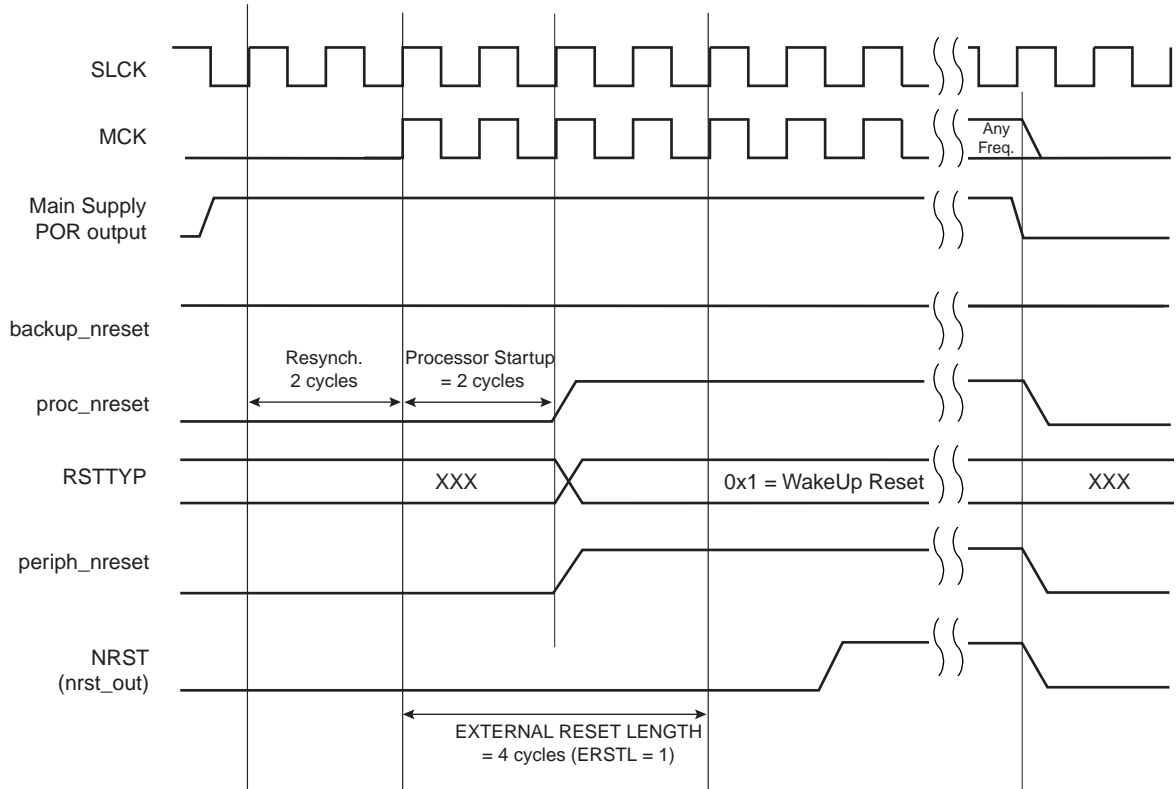

13.4.4.3 User Reset

The User Reset is entered when a low level is detected on the NRST pin and the bit URSTEN in RSTC_MR is at 1. The NRST input signal is resynchronized with SLCK to insure proper behavior of the system.

The User Reset is entered as soon as a low level is detected on NRST. The Processor Reset and the Peripheral Reset are asserted.

The User Reset is left when NRST rises, after a two-cycle resynchronization time and a 2-cycle processor startup. The processor clock is re-enabled as soon as NRST is confirmed high.

When the processor reset signal is released, the RSTTYP field of the Status Register (RSTC_SR) is loaded with the value 0x4, indicating a User Reset.

The NRST Manager guarantees that the NRST line is asserted for EXTERNAL_RESET_LENGTH Slow Clock cycles, as programmed in the field ERSTL. However, if NRST does not rise after EXTERNAL_RESET_LENGTH because it is driven low externally, the internal reset lines remain asserted until NRST actually rises.

Figure 13-6. User Reset State

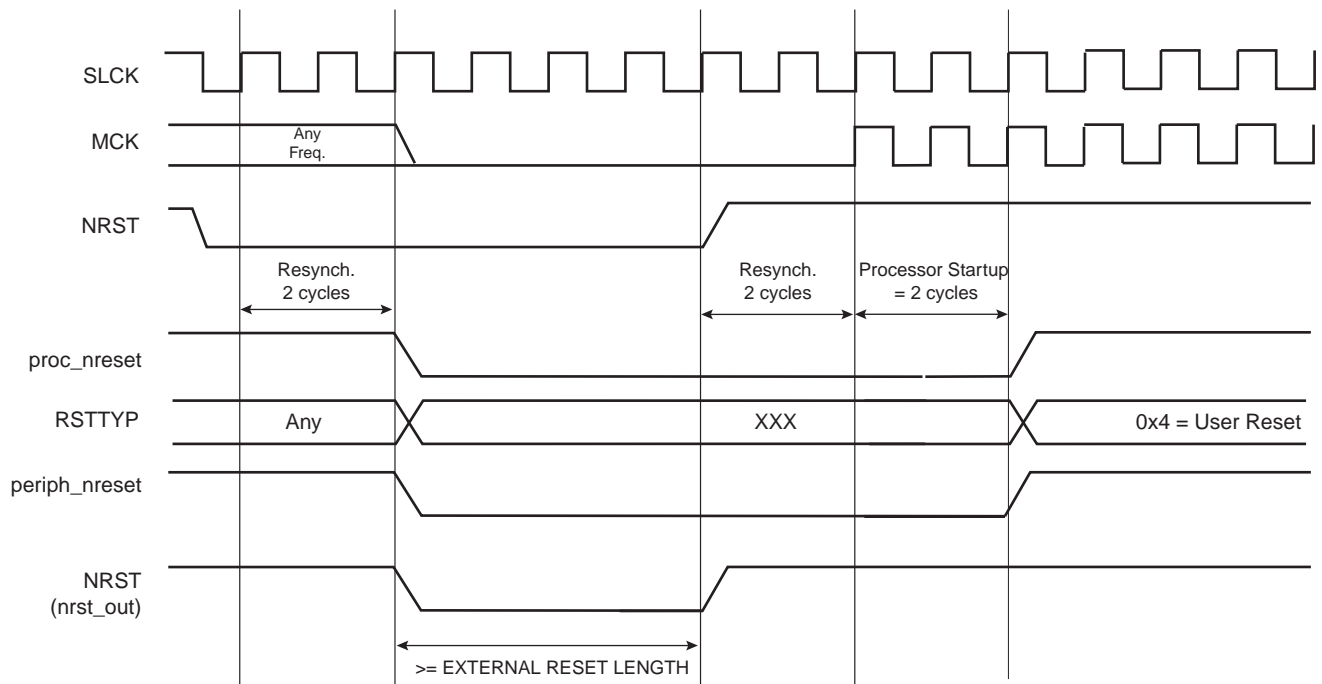

13.4.4.4 Software Reset

The Reset Controller offers several commands used to assert the different reset signals. These commands are performed by writing the Control Register (RSTC_CR) with the following bits at 1:

- PROCRST: Writing PROCRST at 1 resets the processor and the watchdog timer.
- PERRST: Writing PERRST at 1 resets all the embedded peripherals, including the memory system, and, in particular, the Remap Command. The Peripheral Reset is generally used for debug purposes. Except for Debug purposes, PERRST must always be used in conjunction with PROCRST (PERRST and PROCRST set both at 1 simultaneously.)
- EXTRST: Writing EXTRST at 1 asserts low the NRST pin during a time defined by the field ERSTL in the Mode Register (RSTC_MR).

The software reset is entered if at least one of these bits is set by the software. All these commands can be performed independently or simultaneously. The software reset lasts 2 Slow Clock cycles.

The internal reset signals are asserted as soon as the register write is performed. This is detected on the Master Clock (MCK). They are released when the software reset is left, i.e.; synchronously to SLCK.

If EXTRST is set, the nrst_out signal is asserted depending on the programming of the field ERSTL. However, the resulting falling edge on NRST does not lead to a User Reset.

If and only if the PROCRST bit is set, the Reset Controller reports the software status in the field RSTTYP of the Status Register (RSTC_SR). Other Software Resets are not reported in RSTTYP.

As soon as a software operation is detected, the bit SRCMP (Software Reset Command in Progress) is set in the Status Register (RSTC_SR). It is cleared as soon as the software reset is left. No other software reset can be performed while the SRCMP bit is set, and writing any value in RSTC_CR has no effect.

Figure 13-7. Software Reset

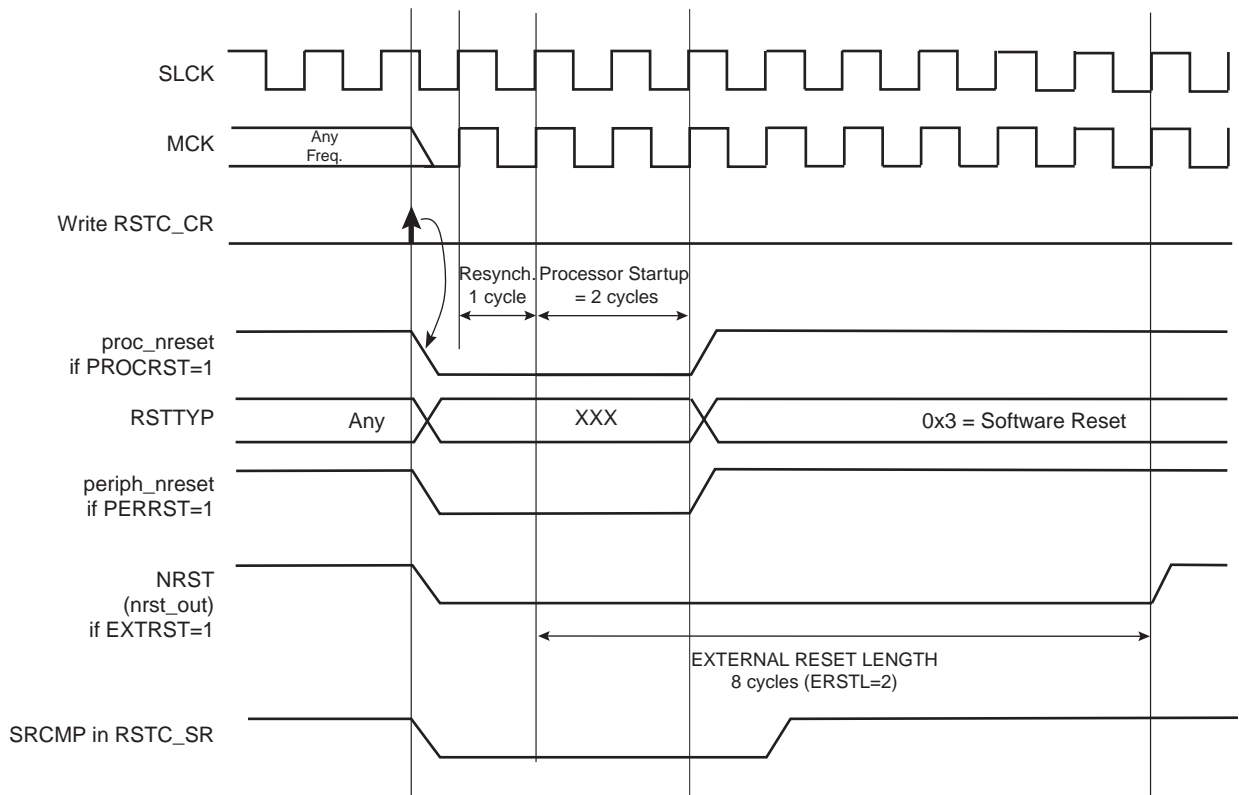

13.4.4.5 Watchdog Reset

The Watchdog Reset is entered when a watchdog fault occurs. This state lasts 2 Slow Clock cycles.

When in Watchdog Reset, assertion of the reset signals depends on the WDRPROC bit in WDT_MR:

- If WDRPROC is 0, the Processor Reset and the Peripheral Reset are asserted. The NRST line is also asserted, depending on the programming of the field ERSTL. However, the resulting low level on NRST does not result in a User Reset state.
- If WDRPROC = 1, only the processor reset is asserted.

The Watchdog Timer is reset by the proc_nreset signal. As the watchdog fault always causes a processor reset if WDRSTEN is set, the Watchdog Timer is always reset after a Watchdog Reset, and the Watchdog is enabled by default and with a period set to a maximum.

When the WDRSTEN in WDT_MR bit is reset, the watchdog fault has no impact on the reset controller.

Figure 13-8. Watchdog Reset

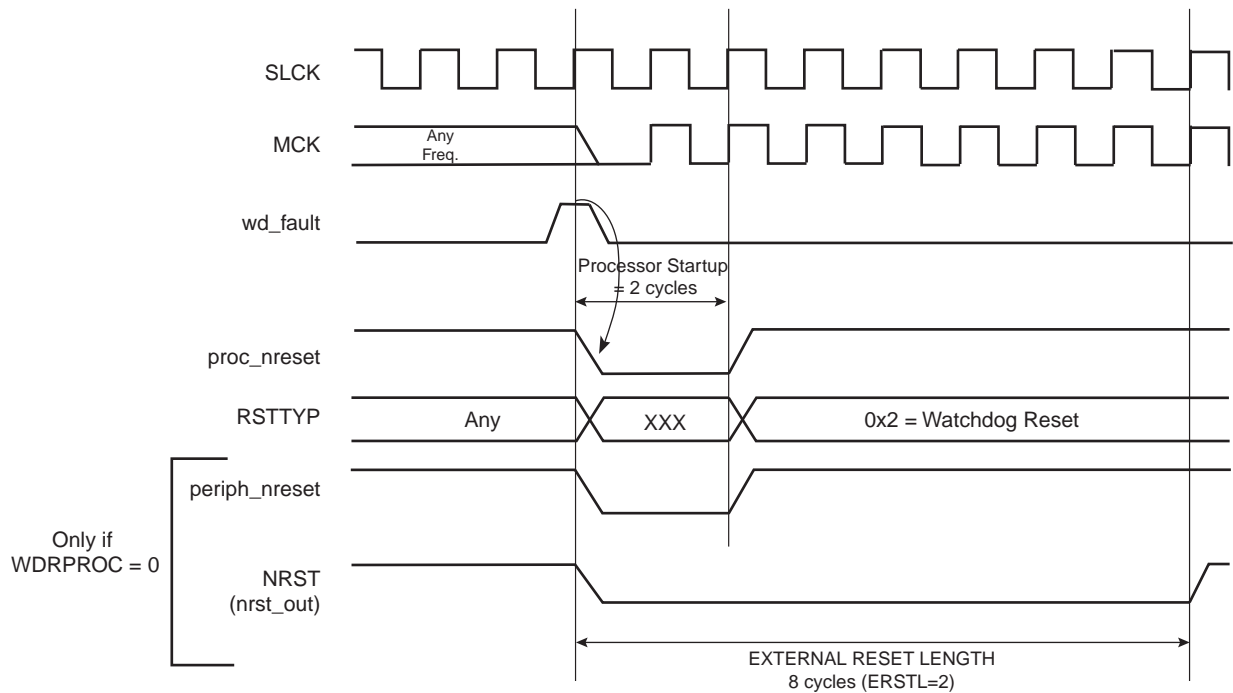

13.4.5 Reset State Priorities

The Reset State Manager manages the following priorities between the different reset sources, given in descending order:

- Backup Reset
- Wakeup Reset
- Watchdog Reset
- Software Reset
- User Reset

Particular cases are listed below:

- When in User Reset:
 - A watchdog event is impossible because the Watchdog Timer is being reset by the `proc_nreset` signal.
 - A software reset is impossible, since the processor reset is being activated.
- When in Software Reset:
 - A watchdog event has priority over the current state.
 - The NRST has no effect.
- When in Watchdog Reset:
 - The processor reset is active and so a Software Reset cannot be programmed.
 - A User Reset cannot be entered.

13.4.6 Reset Controller Status Register

The Reset Controller Status Register (RSTC_SR) provides several status fields:

- RSTTYP field: This field gives the type of the last reset, as explained in previous sections.
- SRCMP bit: This field indicates that a Software Reset Command is in progress and that no further software reset should be performed until the end of the current one. This bit is automatically cleared at the end of the current software reset.
- NRSTL bit: The NRSTL bit of the Status Register gives the level of the NRST pin sampled on each MCK rising edge.
- URSTS bit: A high-to-low transition of the NRST pin sets the URSTS bit of the RSTC_SR. This transition is also detected on the Master Clock (MCK) rising edge (see Figure 13-9). If the User Reset is disabled (URSTEN = 0) and if the interruption is enabled by the URSTIEN bit in the RSTC_MR, the URSTS bit triggers an interrupt. Reading the RSTC_SR resets the URSTS bit and clears the interrupt.

Figure 13-9. Reset Controller Status and Interrupt

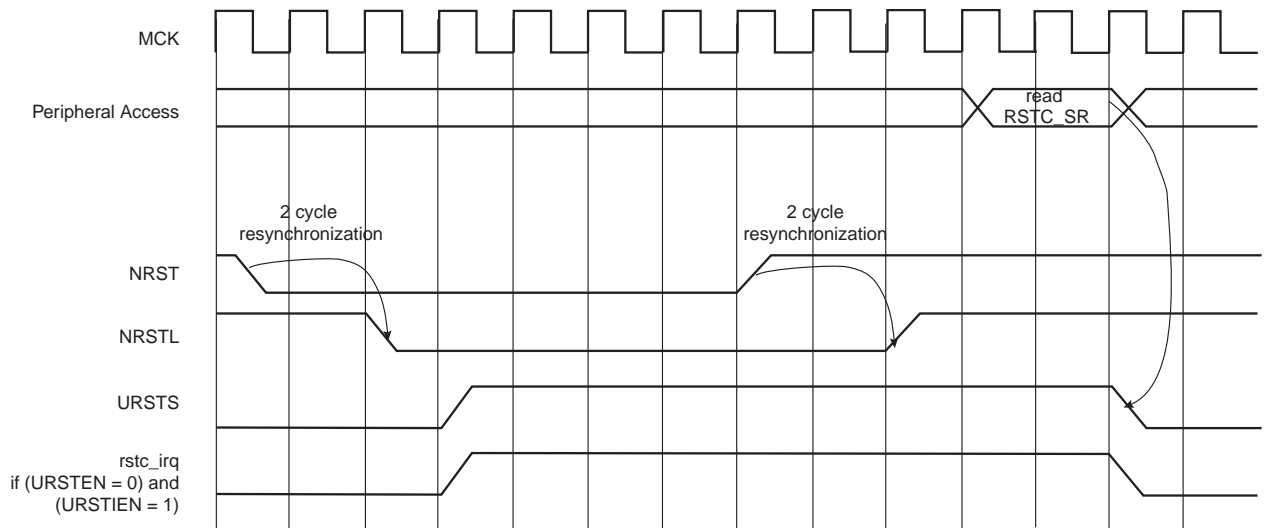

13.5 Reset Controller (RSTC) User Interface

Table 13-1. Register Mapping

| Offset | Register | Name | Access | Reset | Backup Reset |
|--------|--------------------------------|---------|------------|-------------|--------------|
| 0x00 | Control Register | RSTC_CR | Write-only | - | |
| 0x04 | Status Register ⁽¹⁾ | RSTC_SR | Read-only | 0x0000_0001 | 0x0000_0000 |
| 0x08 | Mode Register | RSTC_MR | Read/Write | - | 0x0000_0000 |

Note: 1. The reset value of RSTC_SR either reports a General Reset or a Wakeup Reset depending on last rising power supply.

13.5.1 Reset Controller Control Register

Name: RSTC_CR
Address: 0xFFFFFD00
Access: Write-only

| | | | | | | | |
|-----|----|----|----|--------|--------|----|---------|
| 31 | 30 | 29 | 28 | 27 | 26 | 25 | 24 |
| KEY | | | | | | | |
| 23 | 22 | 21 | 20 | 19 | 18 | 17 | 16 |
| – | – | – | – | – | – | – | – |
| 15 | 14 | 13 | 12 | 11 | 10 | 9 | 8 |
| – | – | – | – | – | – | – | – |
| 7 | 6 | 5 | 4 | 3 | 2 | 1 | 0 |
| – | – | – | – | EXTRST | PERRST | – | PROCRST |

- **PROCRST: Processor Reset**

0: No effect.

1: If KEY is correct, resets the processor.

- **PERRST: Peripheral Reset**

0: No effect.

1: If KEY is correct, resets the peripherals.

- **EXTRST: External Reset**

0: No effect.

1: If KEY is correct, asserts the NRST pin.

- **KEY: Password**

Should be written at value 0xA5. Writing any other value in this field aborts the write operation.

13.5.2 Reset Controller Status Register

Name: RSTC_SR
Address: 0xFFFFFD04
Access: Read-only

| | | | | | | | |
|----|----|----|----|----|--------|-------|-------|
| 31 | 30 | 29 | 28 | 27 | 26 | 25 | 24 |
| – | – | – | – | – | – | – | – |
| 23 | 22 | 21 | 20 | 19 | 18 | 17 | 16 |
| – | – | – | – | – | – | SRCMP | NRSTL |
| 15 | 14 | 13 | 12 | 11 | 10 | 9 | 8 |
| – | – | – | – | – | RSTTYP | | |
| 7 | 6 | 5 | 4 | 3 | 2 | 1 | 0 |
| – | – | – | – | – | – | – | URSTS |

- **URSTS: User Reset Status**

0: No high-to-low edge on NRST happened since the last read of RSTC_SR.

1: At least one high-to-low transition of NRST has been detected since the last read of RSTC_SR.

- **RSTTYP: Reset Type**

Reports the cause of the last processor reset. Reading this RSTC_SR does not reset this field.

| RSTTYP | | | Reset Type | Comments |
|--------|---|---|----------------|--|
| 0 | 0 | 0 | General Reset | Both VDDCORE and VDDBU rising |
| 0 | 0 | 1 | Wakeup Reset | VDDCORE rising |
| 0 | 1 | 0 | Watchdog Reset | Watchdog fault occurred |
| 0 | 1 | 1 | Software Reset | Processor reset required by the software |
| 1 | 0 | 0 | User Reset | NRST pin detected low |

- **NRSTL: NRST Pin Level**

Registers the NRST Pin Level at Master Clock (MCK).

- **SRCMP: Software Reset Command in Progress**

0: No software command is being performed by the reset controller. The reset controller is ready for a software command.

1: A software reset command is being performed by the reset controller. The reset controller is busy.

13.5.3 Reset Controller Mode Register

Name: RSTC_MR
Address: 0xFFFFFD08
Access: Read/Write

| | | | | | | | |
|-----|----|----|---------|-------|----|----|--------|
| 31 | 30 | 29 | 28 | 27 | 26 | 25 | 24 |
| KEY | | | | | | | |
| 23 | 22 | 21 | 20 | 19 | 18 | 17 | 16 |
| – | – | – | – | – | – | – | |
| 15 | 14 | 13 | 12 | 11 | 10 | 9 | 8 |
| – | – | – | – | ERSTL | | | |
| 7 | 6 | 5 | 4 | 3 | 2 | 1 | 0 |
| – | – | | URSTIEN | – | – | – | URSTEN |

- **URSTEN: User Reset Enable**

0: The detection of a low level on the pin NRST does not generate a User Reset.

1: The detection of a low level on the pin NRST triggers a User Reset.

- **URSTIEN: User Reset Interrupt Enable**

0: USRTS bit in RSTC_SR at 1 has no effect on rstc_irq.

1: USRTS bit in RSTC_SR at 1 asserts rstc_irq if URSTEN = 0.

- **ERSTL: External Reset Length**

This field defines the external reset length. The external reset is asserted during a time of $2^{(ERSTL+1)}$ Slow Clock cycles. This allows assertion duration to be programmed between 60 μ s and 2 seconds.

- **KEY: Password**

Should be written at value 0xA5. Writing any other value in this field aborts the write operation.

14. Real-time Timer (RTT)

14.1 Overview

The Real-time Timer is built around a 32-bit counter and used to count elapsed seconds. It generates a periodic interrupt and/or triggers an alarm on a programmed value.

14.2 Embedded Characteristics

- 32-bit Free-running backup counter
- Alarm Register capable to generate a wakeup of the system

14.3 Block Diagram

Figure 14-1. Real-time Timer

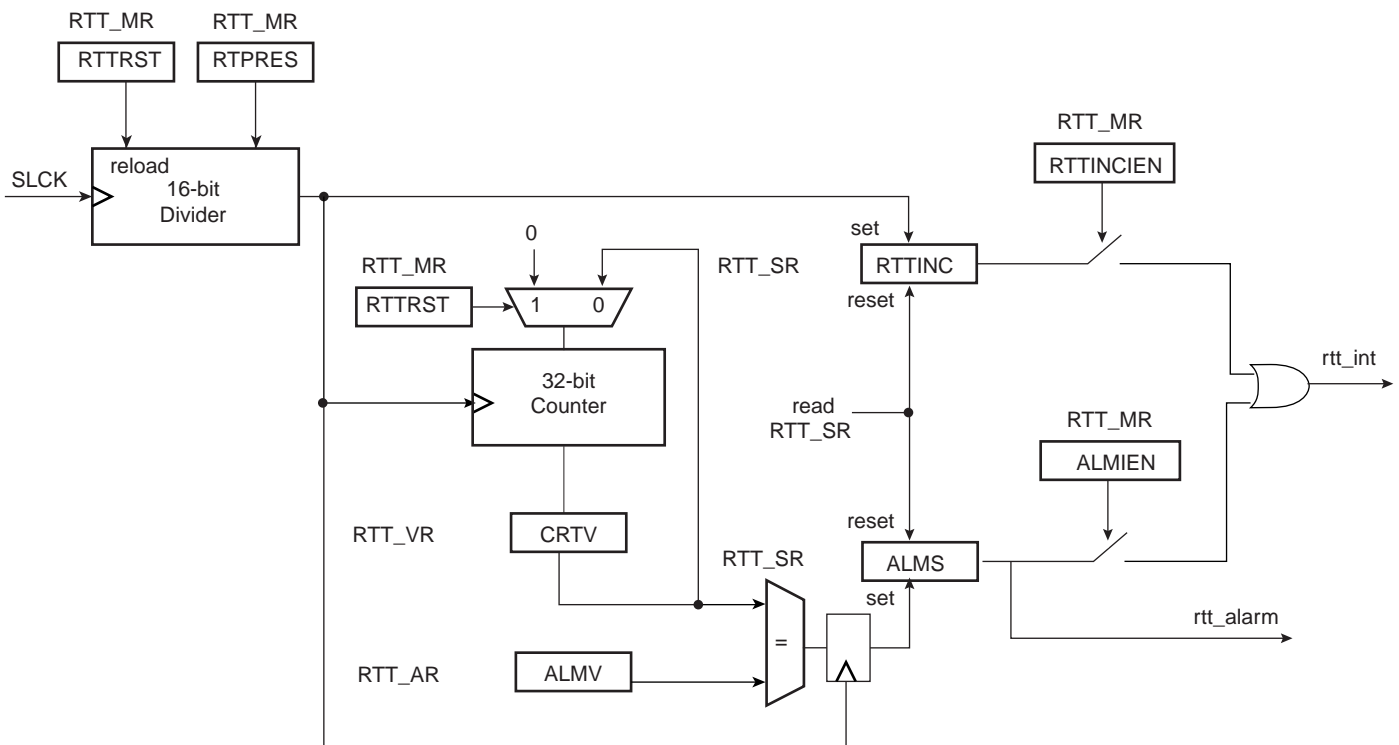

14.4 Functional Description

The Real-time Timer is used to count elapsed seconds. It is built around a 32-bit counter fed by Slow Clock divided by a programmable 16-bit value. The value can be programmed in the field RTPRES of the Real-time Mode Register (RTT_MR).

Programming RTPRES at 0x00008000 corresponds to feeding the real-time counter with a 1 Hz signal (if the Slow Clock is 32.768 Hz). The 32-bit counter can count up to 2^{32} seconds, corresponding to more than 136 years, then roll over to 0.

The Real-time Timer can also be used as a free-running timer with a lower time-base. The best accuracy is achieved by writing RTPRES to 3. Programming RTPRES to 1 or 2 is possible, but may result in losing status events because the status register is cleared two Slow Clock cycles after read. Thus if the RTT is configured to trigger an interrupt, the interrupt occurs during 2 Slow Clock cycles after reading RTT_SR. To prevent several

executions of the interrupt handler, the interrupt must be disabled in the interrupt handler and re-enabled when the status register is clear.

The Real-time Timer value (CRTL) can be read at any time in the register RTT_VR (Real-time Value Register). As this value can be updated asynchronously from the Master Clock, it is advisable to read this register twice at the same value to improve accuracy of the returned value.

The current value of the counter is compared with the value written in the alarm register RTT_AR (Real-time Alarm Register). If the counter value matches the alarm, the bit ALMS in RTT_SR is set. The alarm register is set to its maximum value, corresponding to 0xFFFF_FFFF, after a reset.

The bit RTTINC in RTT_SR is set each time the Real-time Timer counter is incremented. This bit can be used to start a periodic interrupt, the period being one second when the RTPRES is programmed with 0x8000 and Slow Clock equal to 32.768 Hz.

Reading the RTT_SR resets the RTTINC and ALMS fields.

Writing the bit RTRRST in RTT_MR immediately reloads and restarts the clock divider with the new programmed value. This also resets the 32-bit counter.

- Note: Because of the asynchronism between the Slow Clock (SCLK) and the System Clock (MCK):
- 1) The restart of the counter and the reset of the RTT_VR current value register is effective only 2 slow clock cycles after the write of the RTRRST bit in the RTT_MR.
 - 2) The status register flags reset is taken into account only two slow clock cycles after the read of the RTT_SR (Status Register).

Figure 14-2. RTT Counting

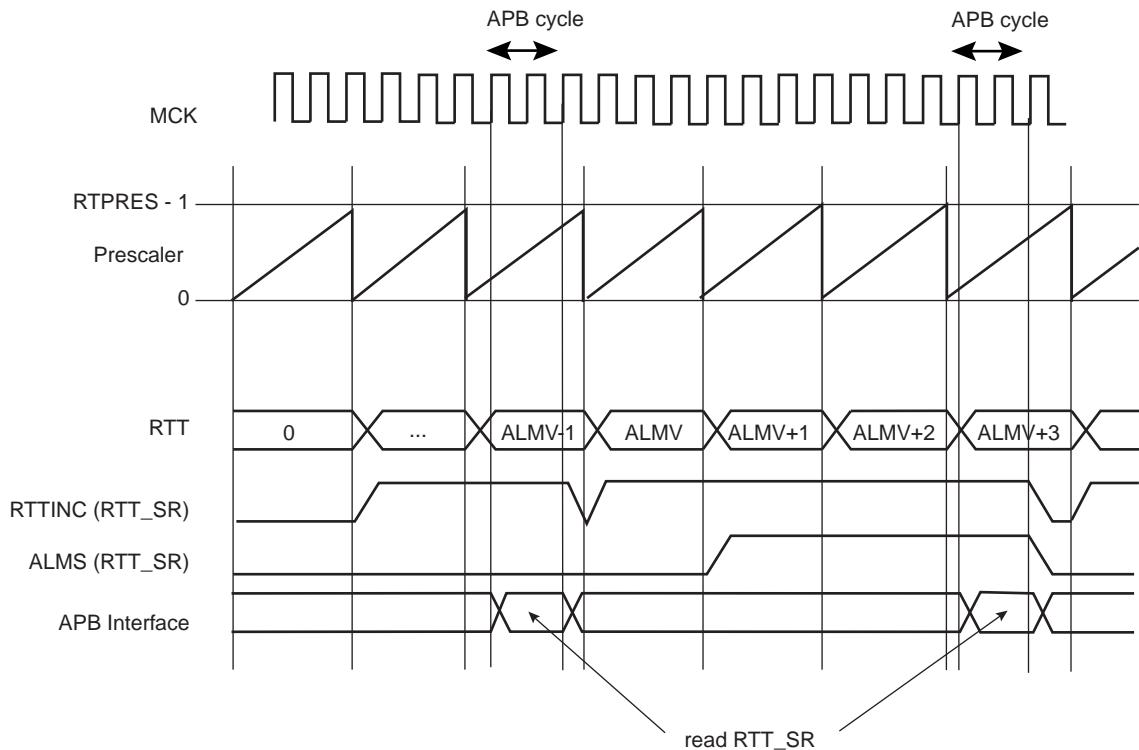

14.5 Real-time Timer (RTT) User Interface

Table 14-1. Register Mapping

| Offset | Register | Name | Access | Reset |
|--------|-----------------|--------|------------|-------------|
| 0x00 | Mode Register | RTT_MR | Read/Write | 0x0000_8000 |
| 0x04 | Alarm Register | RTT_AR | Read/Write | 0xFFFF_FFFF |
| 0x08 | Value Register | RTT_VR | Read-only | 0x0000_0000 |
| 0x0C | Status Register | RTT_SR | Read-only | 0x0000_0000 |

14.5.1 Real-time Timer Mode Register

Name: RTT_MR

Address: 0xFFFFFD20

Access: Read/Write

| | | | | | | | |
|--------|----|----|----|----|--------|-----------|--------|
| 31 | 30 | 29 | 28 | 27 | 26 | 25 | 24 |
| – | – | – | – | – | – | – | – |
| 23 | 22 | 21 | 20 | 19 | 18 | 17 | 16 |
| – | – | – | – | – | RTTRST | RTTINCIEN | ALMIEN |
| 15 | 14 | 13 | 12 | 11 | 10 | 9 | 8 |
| RTPRES | | | | | | | |
| 7 | 6 | 5 | 4 | 3 | 2 | 1 | 0 |
| RTPRES | | | | | | | |

- **RTPRES: Real-time Timer Prescaler Value**

Defines the number of SLCK periods required to increment the Real-time timer. RTPRES is defined as follows:

RTPRES = 0: The prescaler period is equal to 2^{16} .

RTPRES \neq 0: The prescaler period is equal to RTPRES.

- **ALMIEN: Alarm Interrupt Enable**

0: The bit ALMS in RTT_SR has no effect on interrupt.

1: The bit ALMS in RTT_SR asserts interrupt.

- **RTTINCIEN: Real-time Timer Increment Interrupt Enable**

0: The bit RTTINC in RTT_SR has no effect on interrupt.

1: The bit RTTINC in RTT_SR asserts interrupt.

- **RTTRST: Real-time Timer Restart**

1: Reloads and restarts the clock divider with the new programmed value. This also resets the 32-bit counter.

14.5.2 Real-time Timer Alarm Register

Name: RTT_AR

Address: 0xFFFFFD24

Access: Read/Write

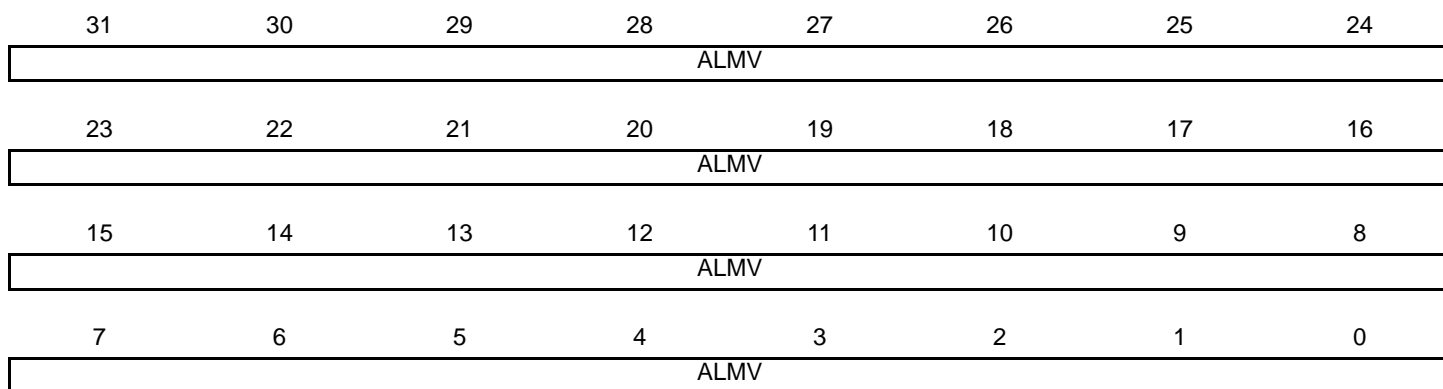

- **ALMV: Alarm Value**

Defines the alarm value (ALMV+1) compared with the Real-time Timer.

14.5.3 Real-time Timer Value Register

Name: RTT_VR

Address: 0xFFFFFD28

Access: Read-only

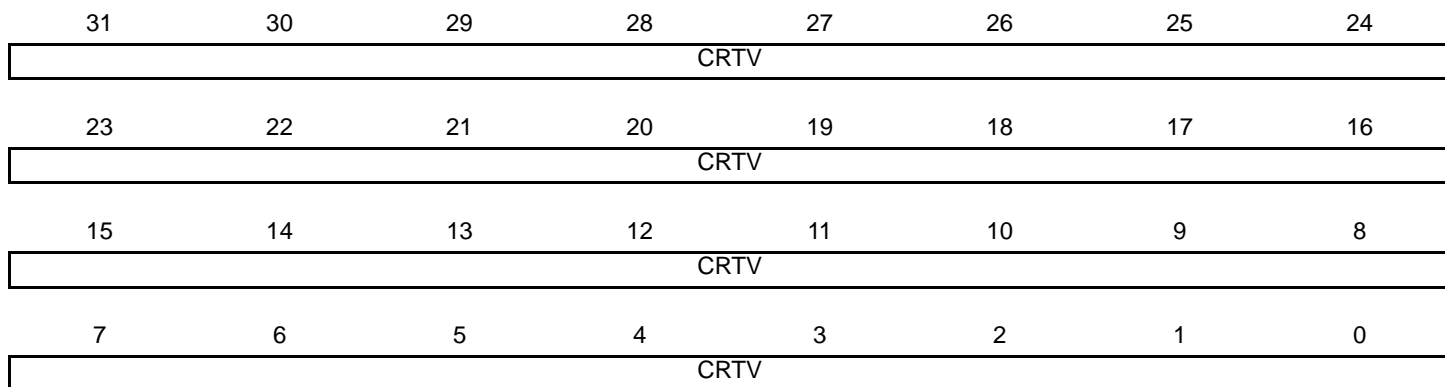

- **CRTV: Current Real-time Value**

Returns the current value of the Real-time Timer.

14.5.4 Real-time Timer Status Register

Name: RTT_SR

Address: 0xFFFFFD2C

Access: Read-only

| | | | | | | | |
|----|----|----|----|----|----|--------|------|
| 31 | 30 | 29 | 28 | 27 | 26 | 25 | 24 |
| – | – | – | – | – | – | – | – |
| 23 | 22 | 21 | 20 | 19 | 18 | 17 | 16 |
| – | – | – | – | – | – | – | – |
| 15 | 14 | 13 | 12 | 11 | 10 | 9 | 8 |
| – | – | – | – | – | – | – | – |
| 7 | 6 | 5 | 4 | 3 | 2 | 1 | 0 |
| – | – | – | – | – | – | RTTINC | ALMS |

- **ALMS: Real-time Alarm Status**

0: The Real-time Alarm has not occurred since the last read of RTT_SR.

1: The Real-time Alarm occurred since the last read of RTT_SR.

- **RTTINC: Real-time Timer Increment**

0: The Real-time Timer has not been incremented since the last read of the RTT_SR.

1: The Real-time Timer has been incremented since the last read of the RTT_SR.

15. Periodic Interval Timer (PIT)

15.1 Overview

The Periodic Interval Timer (PIT) provides the operating system's scheduler interrupt. It is designed to offer maximum accuracy and efficient management, even for systems with long response time.

15.2 Embedded Characteristics

- Includes a 20-bit Periodic Counter with less than 1 μ s accuracy
- Includes a 12-bit Interval Overlay Counter
- Real time OS or Linux®/WindowsCE® compliant tick generator

15.3 Block Diagram

Figure 15-1. Periodic Interval Timer

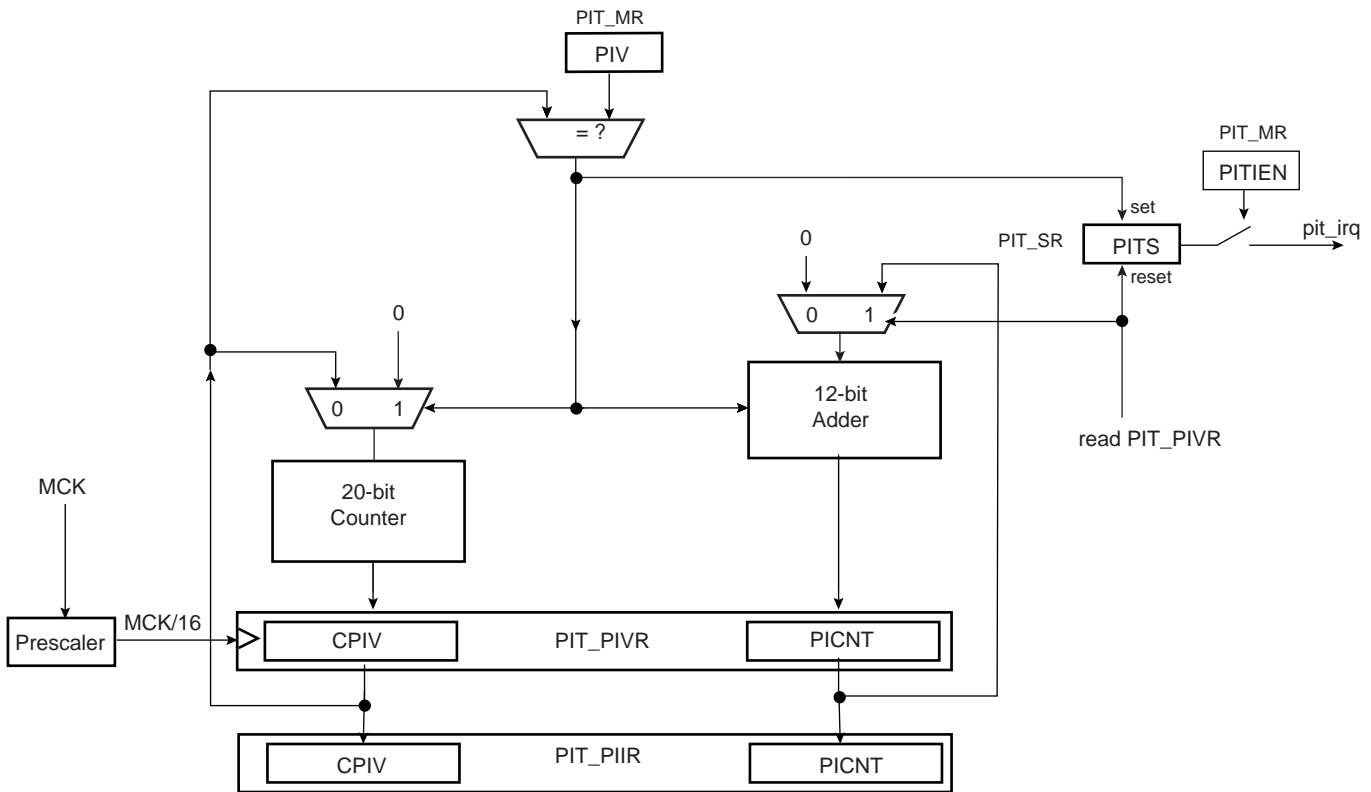

15.4 Functional Description

The Periodic Interval Timer aims at providing periodic interrupts for use by operating systems.

The PIT provides a programmable overflow counter and a reset-on-read feature. It is built around two counters: a 20-bit CPIV counter and a 12-bit PICNT counter. Both counters work at Master Clock /16.

The first 20-bit CPIV counter increments from 0 up to a programmable overflow value set in the field PIV of the Mode Register (PIT_MR). When the counter CPIV reaches this value, it resets to 0 and increments the Periodic Interval Counter, PICNT. The status bit PITS in the Status Register (PIT_SR) rises and triggers an interrupt, provided the interrupt is enabled (PITIEN in PIT_MR).

Writing a new PIV value in PIT_MR does not reset/restart the counters.

When CPIV and PICNT values are obtained by reading the Periodic Interval Value Register (PIT_PIVR), the overflow counter (PICNT) is reset and the PITS is cleared, thus acknowledging the interrupt. The value of PICNT gives the number of periodic intervals elapsed since the last read of PIT_PIVR.

When CPIV and PICNT values are obtained by reading the Periodic Interval Image Register (PIT_PIIR), there is no effect on the counters CPIV and PICNT, nor on the bit PITS. For example, a profiler can read PIT_PIIR without clearing any pending interrupt, whereas a timer interrupt clears the interrupt by reading PIT_PIVR.

The PIT may be enabled/disabled using the PITEN bit in the PIT_MR (disabled on reset). The PITEN bit only becomes effective when the CPIV value is 0. Figure 15-2 illustrates the PIT counting. After the PIT Enable bit is reset (PITEN= 0), the CPIV goes on counting until the PIV value is reached, and is then reset. PIT restarts counting, only if the PITEN is set again.

The PIT is stopped when the core enters debug state.

Figure 15-2. Enabling/Disabling PIT with PITEN

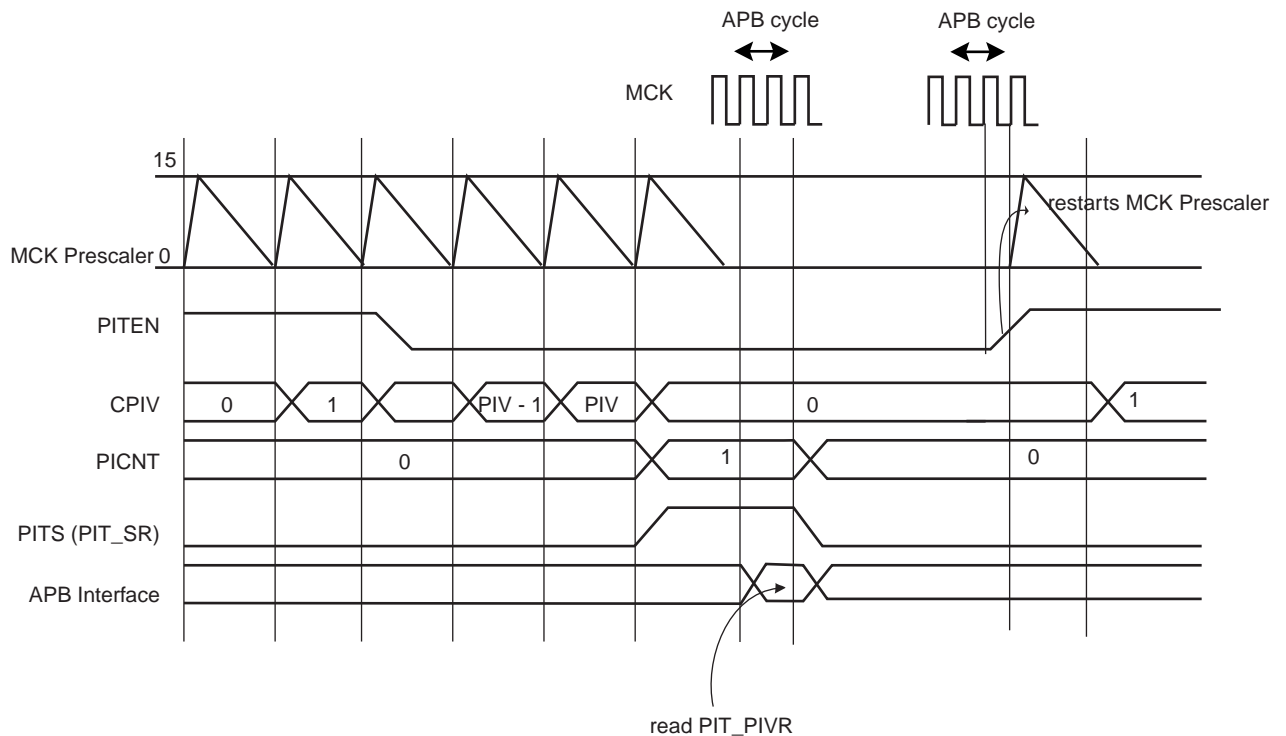

15.5 Periodic Interval Timer (PIT) User Interface

Table 15-1. Register Mapping

| Offset | Register | Name | Access | Reset |
|--------|----------------------------------|----------|------------|-------------|
| 0x00 | Mode Register | PIT_MR | Read/Write | 0x000F_FFFF |
| 0x04 | Status Register | PIT_SR | Read-only | 0x0000_0000 |
| 0x08 | Periodic Interval Value Register | PIT_PIVR | Read-only | 0x0000_0000 |
| 0x0C | Periodic Interval Image Register | PIT_PIIR | Read-only | 0x0000_0000 |

15.5.1 Periodic Interval Timer Mode Register

Name: PIT_MR

Address: 0xFFFFFD30

Access: Read/Write

| | | | | | | | |
|-----|----|----|----|-----|----|--------|-------|
| 31 | 30 | 29 | 28 | 27 | 26 | 25 | 24 |
| – | – | – | – | – | – | PITIEN | PITEN |
| 23 | 22 | 21 | 20 | 19 | 18 | 17 | 16 |
| – | – | – | – | PIV | | | |
| 15 | 14 | 13 | 12 | 11 | 10 | 9 | 8 |
| PIV | | | | | | | |
| 7 | 6 | 5 | 4 | 3 | 2 | 1 | 0 |
| PIV | | | | | | | |

- **PIV: Periodic Interval Value**

Defines the value compared with the primary 20-bit counter of the Periodic Interval Timer (CPIV). The period is equal to (PIV + 1).

- **PITEN: Period Interval Timer Enabled**

0: The Periodic Interval Timer is disabled when the PIV value is reached.

1: The Periodic Interval Timer is enabled.

- **PITIEN: Periodic Interval Timer Interrupt Enable**

0: The bit PITS in PIT_SR has no effect on interrupt.

1: The bit PITS in PIT_SR asserts interrupt.

15.5.2 Periodic Interval Timer Status Register

Name: PIT_SR

Address: 0xFFFFFD34

Access: Read-only

| | | | | | | | |
|----|----|----|----|----|----|----|------|
| 31 | 30 | 29 | 28 | 27 | 26 | 25 | 24 |
| – | – | – | – | – | – | – | – |
| 23 | 22 | 21 | 20 | 19 | 18 | 17 | 16 |
| – | – | – | – | – | – | – | – |
| 15 | 14 | 13 | 12 | 11 | 10 | 9 | 8 |
| – | – | – | – | – | – | – | – |
| 7 | 6 | 5 | 4 | 3 | 2 | 1 | 0 |
| – | – | – | – | – | – | – | PITS |

- **PITS: Periodic Interval Timer Status**

0: The Periodic Interval timer has not reached PIV since the last read of PIT_PIVR.

1: The Periodic Interval timer has reached PIV since the last read of PIT_PIVR.

15.5.3 Periodic Interval Timer Value Register

Name: PIT_PIVR
Address: 0xFFFFFD38
Access: Read-only

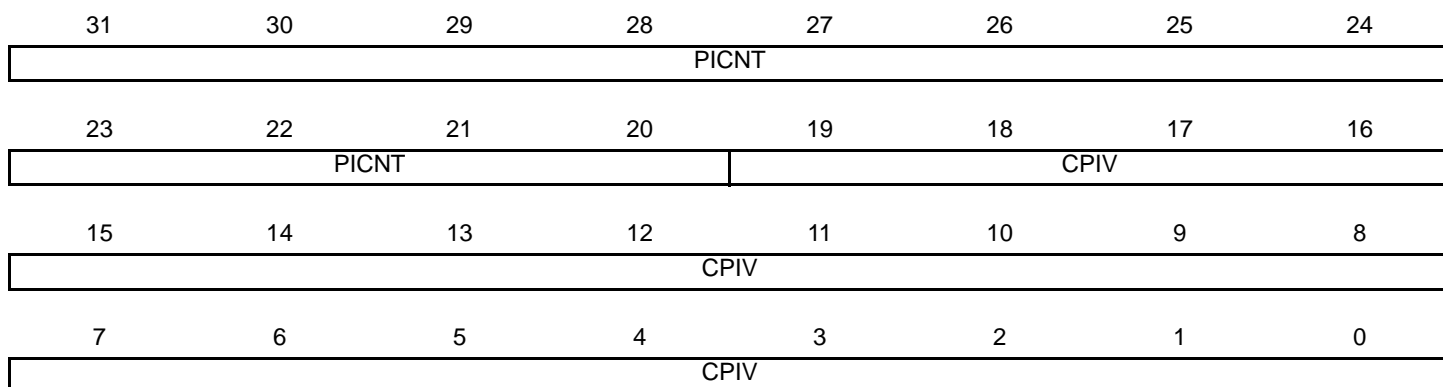

Reading this register clears PITS in PIT_SR.

- **CPIV: Current Periodic Interval Value**

Returns the current value of the periodic interval timer.

- **PICNT: Periodic Interval Counter**

Returns the number of occurrences of periodic intervals since the last read of PIT_PIVR.

15.5.4 Periodic Interval Timer Image Register

Name: PIT_PIRR

Address: 0xFFFFFD3C

Access: Read-only

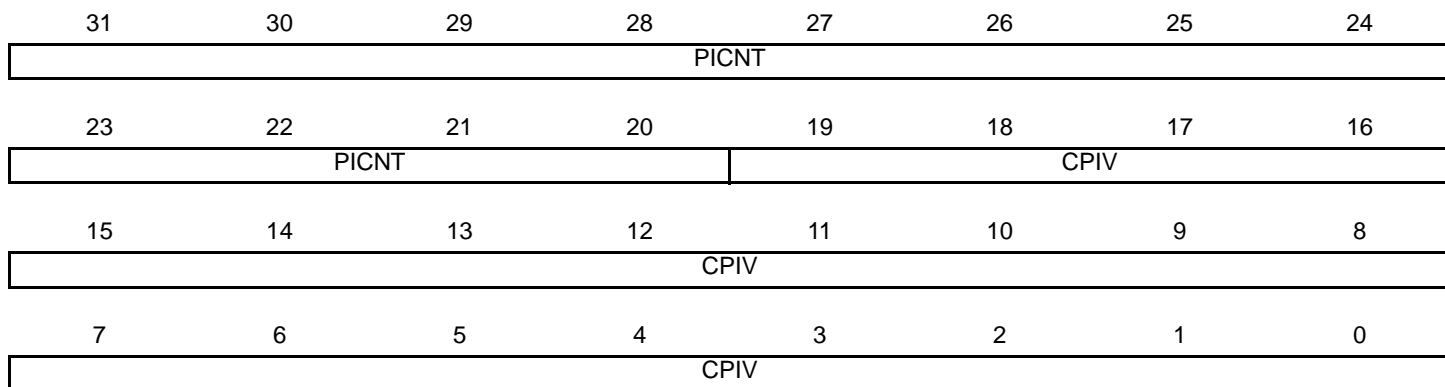

- **CPIV: Current Periodic Interval Value**

Returns the current value of the periodic interval timer.

- **PICNT: Periodic Interval Counter**

Returns the number of occurrences of periodic intervals since the last read of PIT_PIVR.

16. Shutdown Controller (SHDWC)

16.1 Overview

The Shutdown Controller controls the power supplies VDDIO and VDDCORE and the wakeup detection on debounced input lines.

16.2 Embedded Characteristics

- Shutdown and Wakeup logic:
 - Software programmable assertion of the SHDN pin
 - Deassertion Programmable on a WKUP pin level change or on alarm

16.3 Block Diagram

Figure 16-1. Shutdown Controller Block Diagram

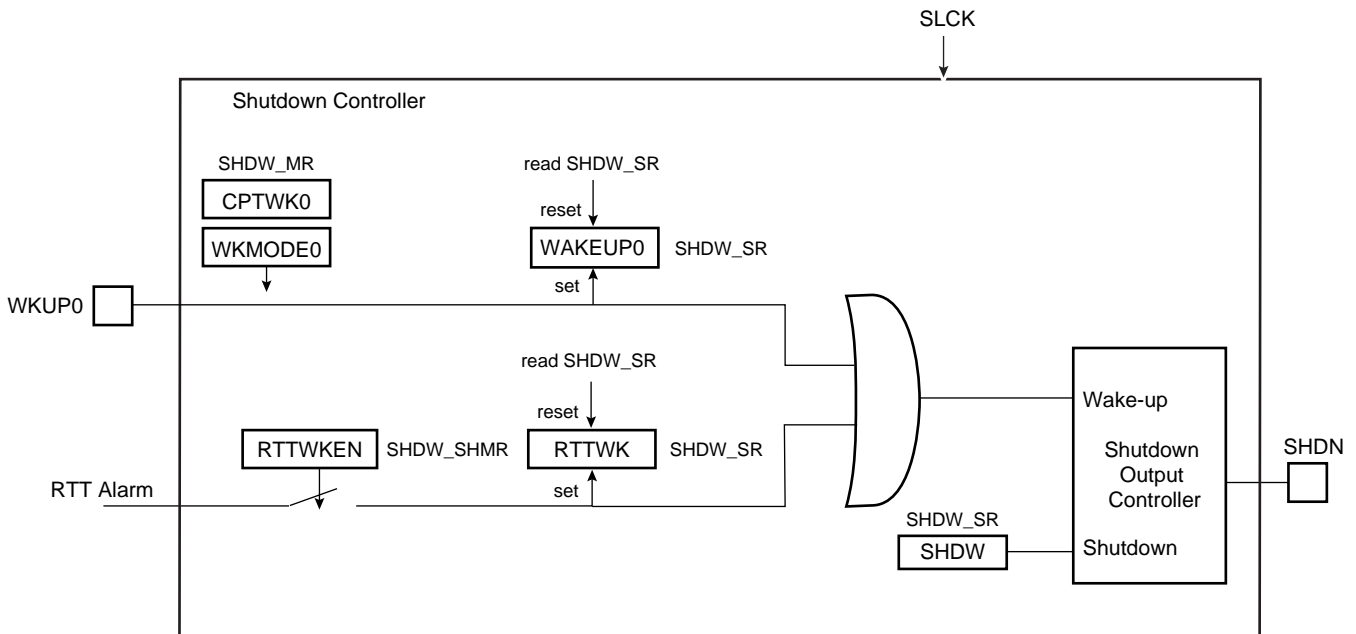

16.4 I/O Lines Description

Table 16-1. I/O Lines Description

| Name | Description | Type |
|-------|-----------------|--------|
| WKUP0 | Wakeup 0 input | Input |
| SHDN | Shutdown output | Output |

16.5 Product Dependencies

16.5.1 Power Management

The Shutdown Controller is continuously clocked by Slow Clock. The Power Management Controller has no effect on the behavior of the Shutdown Controller.

16.6 Functional Description

The Shutdown Controller manages the main power supply. To do so, it is supplied with VDDBU and manages wakeup input pins and one output pin, **SHDN**.

A typical application connects the pin **SHDN** to the shutdown input of the DC/DC Converter providing the main power supplies of the system, and especially VDDCORE and/or VDDIO. The wakeup inputs (WKUP0) connect to any push-buttons or signal that wake up the system.

The software is able to control the pin **SHDN** by writing the Shutdown Control Register (SHDW_CR) with the bit SHDW at 1. The shutdown is taken into account only 2 slow clock cycles after the write of SHDW_CR. This register is password-protected and so the value written should contain the correct key for the command to be taken into account. As a result, the system should be powered down.

A level change on WKUP0 is used as wakeup. Wakeup is configured in the Shutdown Mode Register (SHDW_MR). The transition detector can be programmed to detect either a positive or negative transition or any level change on WKUP0. The detection can also be disabled. Programming is performed by defining WKMODE0.

Moreover, a debouncing circuit can be programmed for WKUP0. The debouncing circuit filters pulses on WKUP0 shorter than the programmed number of 16 SLCK cycles in CPTWK0 of the SHDW_MR. If the programmed level change is detected on a pin, a counter starts. When the counter reaches the value programmed in the corresponding field, CPTWK0, the **SHDN** pin is released. If a new input change is detected before the counter reaches the corresponding value, the counter is stopped and cleared. WAKEUP0 of the Status Register (SHDW_SR) reports the detection of the programmed events on WKUP0 with a reset after the read of SHDW_SR.

The Shutdown Controller can be programmed so as to activate the wakeup using the RTT alarm (the detection of the rising edge of the RTT alarm is synchronized with SLCK). This is done by writing the SHDW_MR using the RTTWKEN fields. When enabled, the detection of the RTT alarm is reported in the RTTWK bit of the SHDW_SR Status register. It is reset after the read of SHDW_SR. When using the RTT alarm to wake up the system, the user must ensure that the RTT alarm status flag is cleared before shutting down the system. Otherwise, no rising edge of the status flag may be detected and the wakeup fails.

16.7 Shutdown Controller (SHDWC) User Interface

Table 16-2. Register Mapping

| Offset | Register | Name | Access | Reset |
|--------|---------------------------|---------|------------|-------------|
| 0x00 | Shutdown Control Register | SHDW_CR | Write-only | - |
| 0x04 | Shutdown Mode Register | SHDW_MR | Read/Write | 0x0000_0303 |
| 0x08 | Shutdown Status Register | SHDW_SR | Read-only | 0x0000_0000 |

16.7.1 Shutdown Control Register

Name: SHDW_CR
Address: 0xFFFFFD10
Access: Write-only

| | | | | | | | |
|-----|----|----|----|----|----|----|------|
| 31 | 30 | 29 | 28 | 27 | 26 | 25 | 24 |
| KEY | | | | | | | |
| 23 | 22 | 21 | 20 | 19 | 18 | 17 | 16 |
| - | - | - | - | - | - | - | - |
| 15 | 14 | 13 | 12 | 11 | 10 | 9 | 8 |
| - | - | - | - | - | - | - | - |
| 7 | 6 | 5 | 4 | 3 | 2 | 1 | 0 |
| - | - | - | - | - | - | - | SHDW |

- **SHDW: Shutdown Command**

0: No effect.

1: If KEY is correct, asserts the SHDN pin.

- **KEY: Password**

Should be written at value 0xA5. Writing any other value in this field aborts the write operation.

16.7.2 Shutdown Mode Register

Name: SHDW_MR
Address: 0xFFFFFD14
Access: Read/Write

| | | | | | | | |
|--------|----|----|----|----|----|---------|---------|
| 31 | 30 | 29 | 28 | 27 | 26 | 25 | 24 |
| – | – | – | – | – | – | – | – |
| 23 | 22 | 21 | 20 | 19 | 18 | 17 | 16 |
| – | – | – | – | – | – | – | RTTWKEN |
| 15 | 14 | 13 | 12 | 11 | 10 | 9 | 8 |
| – | | | | – | – | – | |
| 7 | 6 | 5 | 4 | 3 | 2 | 1 | 0 |
| CPTWK0 | | | | – | – | WKMODE0 | |

• WKMODE0: Wakeup Mode 0

| Value | | Wakeup Input Transition Selection |
|-------|---|---|
| 0 | 0 | None. No detection is performed on the wakeup input |
| 0 | 1 | Low to high level |
| 1 | 0 | High to low level |
| 1 | 1 | Both levels change |

• CPTWK0: Counter on Wakeup 0

Defines the number of 16 Slow Clock cycles, the level detection on the corresponding input pin shall last before the wakeup event occurs. Because of the internal synchronization of WKUP0, the SHDN pin is released (CPTWK x 16 + 1) Slow Clock cycles after the event on WKUP.

• RTTWKEN: Real-time Timer Wakeup Enable

0: The RTT Alarm signal has no effect on the Shutdown Controller.

1: The RTT Alarm signal forces the de-assertion of the SHDN pin.

16.7.3 Shutdown Status Register

Name: SHDW_SR

Address: 0xFFFFFD18

Access: Read-only

| | | | | | | | |
|----|----|----|----|----|----|----|---------|
| 31 | 30 | 29 | 28 | 27 | 26 | 25 | 24 |
| – | – | – | – | – | – | – | – |
| 23 | 22 | 21 | 20 | 19 | 18 | 17 | 16 |
| – | – | – | – | – | – | – | RTTWK |
| 15 | 14 | 13 | 12 | 11 | 10 | 9 | 8 |
| – | – | – | – | – | – | – | – |
| 7 | 6 | 5 | 4 | 3 | 2 | 1 | 0 |
| – | – | – | – | – | – | – | WAKEUP0 |

- **WAKEUP0: Wakeup 0 Status**

0: No wakeup event occurred on the corresponding wakeup input since the last read of SHDW_SR.

1: At least one wakeup event occurred on the corresponding wakeup input since the last read of SHDW_SR.

- **RTTWK: Real-time Timer Wakeup**

0: No wakeup alarm from the RTT occurred since the last read of SHDW_SR.

1: At least one wakeup alarm from the RTT occurred since the last read of SHDW_SR.

17. General Purpose Backup Register (GPBR)

17.1 Overview

The System Controller embeds 4 general-purpose backup registers.

17.2 General Purpose Backup Registers (GPBR) User Interface

Table 17-1. Register Mapping

| Offset | Register | Name | Access | Reset |
|--------|-----------------------------------|------------|------------|-------|
| 0x0 | General Purpose Backup Register 0 | SYS_GPBR0 | Read/Write | – |
| ... | ... | ... | ... | ... |
| 0xC | General Purpose Backup Register 3 | SYS_GPBR 3 | Read/Write | – |

17.2.1 General Purpose Backup Register x

Name: SYS_GPBRx

Address: 0xFFFFFD50 [0], 0xFFFFFD54 [1], 0xFFFFFD58 [2], 0xFFFFFD5C [3]

Access: Read/Write

| | | | | | | | |
|-------------|----|----|----|----|----|----|----|
| 31 | 30 | 29 | 28 | 27 | 26 | 25 | 24 |
| GPBR_VALUEx | | | | | | | |
| 23 | 22 | 21 | 20 | 19 | 18 | 17 | 16 |
| GPBR_VALUEx | | | | | | | |
| 15 | 14 | 13 | 12 | 11 | 10 | 9 | 8 |
| GPBR_VALUEx | | | | | | | |
| 7 | 6 | 5 | 4 | 3 | 2 | 1 | 0 |
| GPBR_VALUEx | | | | | | | |

- **GPBR_VALUEx:** Value of GPBR x

18. Bus Matrix

18.1 Overview

The Bus Matrix implements a multi-layer AHB, based on AHB-Lite protocol, that enables parallel access paths between multiple AHB masters and slaves in a system, thus increasing the overall bandwidth. The Bus Matrix interconnects 5 AHB Masters to 5 AHB Slaves. The Bus Matrix user interface is compliant with the ARM Advanced Peripheral Bus and provides 5 Special Function Registers (MATRIX_SFR) that allow the Bus Matrix to support application-specific features.

18.2 Memory Mapping

The Bus Matrix provides one decoder for every AHB Master Interface. The decoder offers each AHB Master several memory mappings. Depending on the product, each memory area may be assigned to several slaves. Booting at the same address while using different AHB slaves (i.e., external RAM, internal ROM, internal Flash, etc.) becomes possible.

The Bus Matrix user interface provides a Master Configuration Register (MATRIX_MCFG) that performs a remap action for every master independently.

18.3 Special Bus Granting Techniques

The Bus Matrix provides some speculative bus granting techniques in order to anticipate access requests from some masters. This technique reduces latency at first accesses. The bus granting technique sets a default master for every slave. At the end of the current access, if no other request is pending, the slave remains connected to its associated default master. A slave can be associated with three kinds of default masters; no default master, last access master and fixed default master.

18.3.1 No Default Master

At the end of current access, if no other request is pending, the slave is disconnected from all masters. No Default Master suits low-power mode.

18.3.2 Last Access Master

At the end of current access, if no other request is pending, the slave remains connected to the last master that performs an access request.

18.3.3 Fixed Default Master

At the end of current access, if no other request is pending, the slave remains connected to its fixed default master. Unlike last access master, the fixed master does not change unless the user changes it by a software action.

To change from one kind of default master to another, the Bus Matrix user interface provides 5 Slave Configuration Registers, one for each slave, that set default master for each slave. The Slave Configuration Register contains two fields; DEFMSTR_TYPE and FIXED_DEFMSTR. The 2-bit DEFMSTR_TYPE flag selects the default master type (no default, last access master, fixed default master) whereas the 3-bit FIXED_DEFMSTR flag selects a fixed default master provided that DEFMSTR_TYPE is set to a fixed default master. See [Section 18.5 “Bus Matrix \(MATRIX\) User Interface”](#).

18.4 Arbitration

The Bus Matrix provides an arbitration function that reduces latency when conflicting cases occur, i.e., when two or more masters try to access the same slave at the same time. The Bus Matrix arbitration mechanism uses slightly modified round-robin algorithms that grant the bus for the first access to a certain master depending on parameters located in the slave's Slave Configuration Register.

There are three round-robin algorithm types:

- Round-Robin arbitration without default master
- Round-Robin arbitration with last access master
- Round-Robin arbitration with fixed default master

18.4.1 Round-Robin Arbitration Without Default Master

This is the main algorithm used by Bus Matrix arbiters. It allows the Bus Matrix to dispatch requests from different masters to the same slave in a pure round-robin manner. At the end of the current access, if no other request is pending, the slave is disconnected from all masters. This configuration incurs one latency cycle for the first access. Arbitration without default master can be used for masters that perform significant bursts.

18.4.2 Round-Robin Arbitration With Last Access Master

This is a biased round-robin algorithm used by Bus Matrix arbiters. It allows the Bus Matrix to remove one latency cycle for the last master that accessed the slave. In fact, at the end of the current transfer, if no other master request is pending, the slave remains connected to the last master that performs the access. Other non-privileged masters still obtain one latency cycle if they want to access the same slave. This technique can be used for masters that perform mainly single accesses.

18.4.3 Round-Robin Arbitration With Fixed Default Master

This is a biased round-robin algorithm. It allows the Bus Matrix arbiters to remove one latency cycle for the fixed master of a slave. At the end of the current access, the slave remains connected to its fixed default master. Any request attempted by this fixed default master does not cause any latency, whereas other non-privileged masters still obtain one latency cycle. This technique can be used for masters that perform mainly single accesses.

18.5 Bus Matrix (MATRIX) User Interface

Table 18-1. Register Mapping

| Offset | Register | Name | Access | Reset |
|---------------|-------------------------------------|--------------|------------|------------|
| 0x0000 | Master Configuration Register | MATRIX_MCFG | Write-only | – |
| 0x0004 | Slave Configuration Register 0 | MATRIX_SCFG0 | Read/Write | 0x00000010 |
| 0x0008 | Slave Configuration Register 1 | MATRIX_SCFG1 | Read/Write | 0x00000010 |
| 0x000C | Slave Configuration Register 2 | MATRIX_SCFG2 | Read/Write | 0x00000010 |
| 0x0010 | Slave Configuration Register 3 | MATRIX_SCFG3 | Read/Write | 0x00000010 |
| 0x0014 | Slave Configuration Register 4 | MATRIX_SCFG4 | Read/Write | 0x00000010 |
| 0x0018–0x0020 | Reserved | – | – | – |
| 0x0024 | MATRIX TCM Configuration Register | MATRIX_TCR | Read/Write | 0x00000000 |
| 0x0028–0x002C | Reserved | – | – | – |
| 0x0030 | EBI Chip Select Assignment Register | EBI_CSA | Read/Write | 0x00000000 |
| 0x0034 | USB Pad Pull-up Control Register | USB_PUCR | Read/Write | 0x00000000 |

18.5.1 Bus Matrix Master Configuration Register

Name: MATRIX_MCFG

Address: 0xFFFFEE00

Access: Write-only

| | | | | | | | |
|----|----|----|----|----|----|------|------|
| 31 | 30 | 29 | 28 | 27 | 26 | 25 | 24 |
| – | – | – | – | – | – | – | – |
| 23 | 22 | 21 | 20 | 19 | 18 | 17 | 16 |
| – | – | – | – | – | – | – | – |
| 15 | 14 | 13 | 12 | 11 | 10 | 9 | 8 |
| – | – | – | – | – | – | – | – |
| 7 | 6 | 5 | 4 | 3 | 2 | 1 | 0 |
| – | – | – | – | – | – | RCB1 | RCB0 |

- **RCBx: Remap Command Bit for AHB Master x**

0: No effect

1: This Command Bit acts on a toggle basis: writing a 1 alternatively cancels and restores the remapping of addressed slaves from master x.

18.5.2 Bus Matrix Slave Configuration Registers

Name: MATRIX_SCFG0...MATRIX_SCFG4

Address: 0xFFFFEE04

Access: Read/Write

| | | | | | | | |
|------------|----|----|---------------|----|----|--------------|----|
| 31 | 30 | 29 | 28 | 27 | 26 | 25 | 24 |
| – | – | – | – | – | – | – | – |
| 23 | 22 | 21 | 20 | 19 | 18 | 17 | 16 |
| – | – | – | FIXED_DEFMSTR | | | DEFMSTR_TYPE | |
| 15 | 14 | 13 | 12 | 11 | 10 | 9 | 8 |
| – | – | – | – | – | – | – | – |
| 7 | 6 | 5 | 4 | 3 | 2 | 1 | 0 |
| SLOT_CYCLE | | | | | | | |

- **SLOT_CYCLE: Maximum Number of Allowed Cycles for a Burst**

When the SLOT_CYCLE limit is reached for a burst, it may be broken by another master trying to access this slave.

This limit has been set to avoid locking very slow slaves when very long bursts are used.

This limit should not be very small. An unreasonably small value breaks every burst and the Bus Matrix spends its time arbitrating without performing any data transfer. 16 cycles is a reasonable value for SLOT_CYCLE.

- **DEFMASTR_TYPE: Default Master Type**

0: No Default Master

At the end of the current slave access, if no other master request is pending, the slave is disconnected from all masters.

This results in one cycle latency for the first transfer of a burst.

1: Last Default Master

At the end of the current slave access, if no other master request is pending, the slave remains connected to the last master that accessed it.

This results in not having the one cycle latency when the last master is trying to access the slave again.

2: Fixed Default Master

At the end of the current slave access, if no other master request is pending, the slave connects with the fixed master that has its index in FIXED_DEFMSTR.

This results in not having the one cycle latency when the fixed master is trying to access the slave again.

- **FIXED_DEFMSTR: Fixed Index of Default Master**

This is the index of the Fixed Default Master for this slave.

18.5.3 Bus Matrix TCM Configuration Register

Name: MATRIX_TCR

Address: 0xFFFFEE24

Access: Read/Write

| | | | | | | | |
|-----------|----|----|----|-----------|----|----|----|
| 31 | 30 | 29 | 28 | 27 | 26 | 25 | 24 |
| – | – | – | – | – | – | – | – |
| 23 | 22 | 21 | 20 | 19 | 18 | 17 | 16 |
| – | – | – | – | – | – | – | – |
| 15 | 14 | 13 | 12 | 11 | 10 | 9 | 8 |
| – | – | – | – | – | – | – | – |
| 7 | 6 | 5 | 4 | 3 | 2 | 1 | 0 |
| DTCM_SIZE | | | | ITCM_SIZE | | | |

- **ITCM_SIZE: Size of ITCM enabled memory block**

0000 0KB (No ITCM Memory)

0101: 16 KB

0110: 32 KB

0111: 64 KB

Others: Reserved

- **DTCM_SIZE: Size of DTCM enabled memory block**

0000 0 KB (No DTCM Memory)

0101: 16 KB

0110: 32 KB

0111: 64 KB

Others: Reserved

18.5.4 EBI Chip Select Assignment Register

Name: EBI_CSA

Address: 0xFFFFEE30

Access: Read/Write

| | | | | | | | |
|----|----|----------|----------|----------|----|----------|-----------|
| 31 | 30 | 29 | 28 | 27 | 26 | 25 | 24 |
| – | – | – | – | – | – | – | – |
| 23 | 22 | 21 | 20 | 19 | 18 | 17 | 16 |
| – | – | – | – | – | – | – | – |
| 15 | 14 | 13 | 12 | 11 | 10 | 9 | 8 |
| – | – | – | – | – | – | – | EBI_DBPUC |
| 7 | 6 | 5 | 4 | 3 | 2 | 1 | 0 |
| – | – | EBI_CS5A | EBI_CS4A | EBI_CS3A | – | EBI_CS1A | – |

- **EBI_CS1A: EBI Chip Select 1 Assignment**

0: EBI Chip Select 1 is assigned to the Static Memory Controller.

1: EBI Chip Select 1 is assigned to the SDRAM Controller.

- **EBI_CS3A: EBI Chip Select 3 Assignment**

0: EBI Chip Select 3 is only assigned to the Static Memory Controller and EBI_NCS3 behaves as defined by the SMC.

1: EBI Chip Select 3 is assigned to the Static Memory Controller and the SmartMedia Logic is activated.

- **EBI_CS4A: EBI Chip Select 4 Assignment**

0: EBI Chip Select 4 is only assigned to the Static Memory Controller and EBI_NCS4 behaves as defined by the SMC.

1: EBI Chip Select 4 is assigned to the Static Memory Controller and the CompactFlash Logic (first slot) is activated.

- **EBI_CS5A: EBI Chip Select 5 Assignment**

0: EBI Chip Select 5 is only assigned to the Static Memory Controller and EBI_NCS5 behaves as defined by the SMC.

1: EBI Chip Select 5 is assigned to the Static Memory Controller and the CompactFlash Logic (second slot) is activated.

- **EBI_DBPUC: EBI Data Bus Pull-Up Configuration**

0: EBI D0–D15 Data Bus bits are internally pulled up to the VDDIOM power supply.

1: EBI D0–D15 Data Bus bits are not internally pulled up.

18.5.5 USB Pad Pull-up Control Register

Name: USB_PUCR

Address: 0xFFFFFEE34

Access: Read/Write

| | | | | | | | |
|----------|------------|----|----|----|----|----|----|
| 31 | 30 | 29 | 28 | 27 | 26 | 25 | 24 |
| Reserved | UDP_PUP_ON | – | – | – | – | – | – |
| 23 | 22 | 21 | 20 | 19 | 18 | 17 | 16 |
| – | – | – | – | – | – | – | – |
| 15 | 14 | 13 | 12 | 11 | 10 | 9 | 8 |
| – | – | – | – | – | – | – | – |
| 7 | 6 | 5 | 4 | 3 | 2 | 1 | 0 |
| – | – | – | – | – | – | – | – |

- **UDP_PUP_ON: UDP Pad Pull-up Enable**

0: Pad pull-up disabled

1: Pad pull-up enabled

19. External Bus Interface (EBI)

19.1 Overview

The External Bus Interface (EBI) is designed to ensure the successful data transfer between several external devices and the embedded Memory Controller of an ARM-based device. The Static Memory and SDRAM Controllers are all featured external Memory Controllers on the EBI. These external Memory Controllers are capable of handling several types of external memory and peripheral devices, such as SRAM, PROM, EPROM, EEPROM, Flash, and SDRAM.

The EBI also supports the CompactFlash and the NAND Flash protocols via integrated circuitry that greatly reduces the requirements for external components. Furthermore, the EBI handles data transfers with up to eight external devices, each assigned to eight address spaces defined by the embedded Memory Controller. Data transfers are performed through a 16-bit or 32-bit data bus, an address bus of up to 26 bits, up to eight chip select lines (NCS[7:0]) and several control pins that are generally multiplexed between the different external Memory Controllers.

19.2 Block Diagram

Figure 19-1 shows the organization of the External Bus Interface.

Figure 19-1. Organization of the External Bus Interface

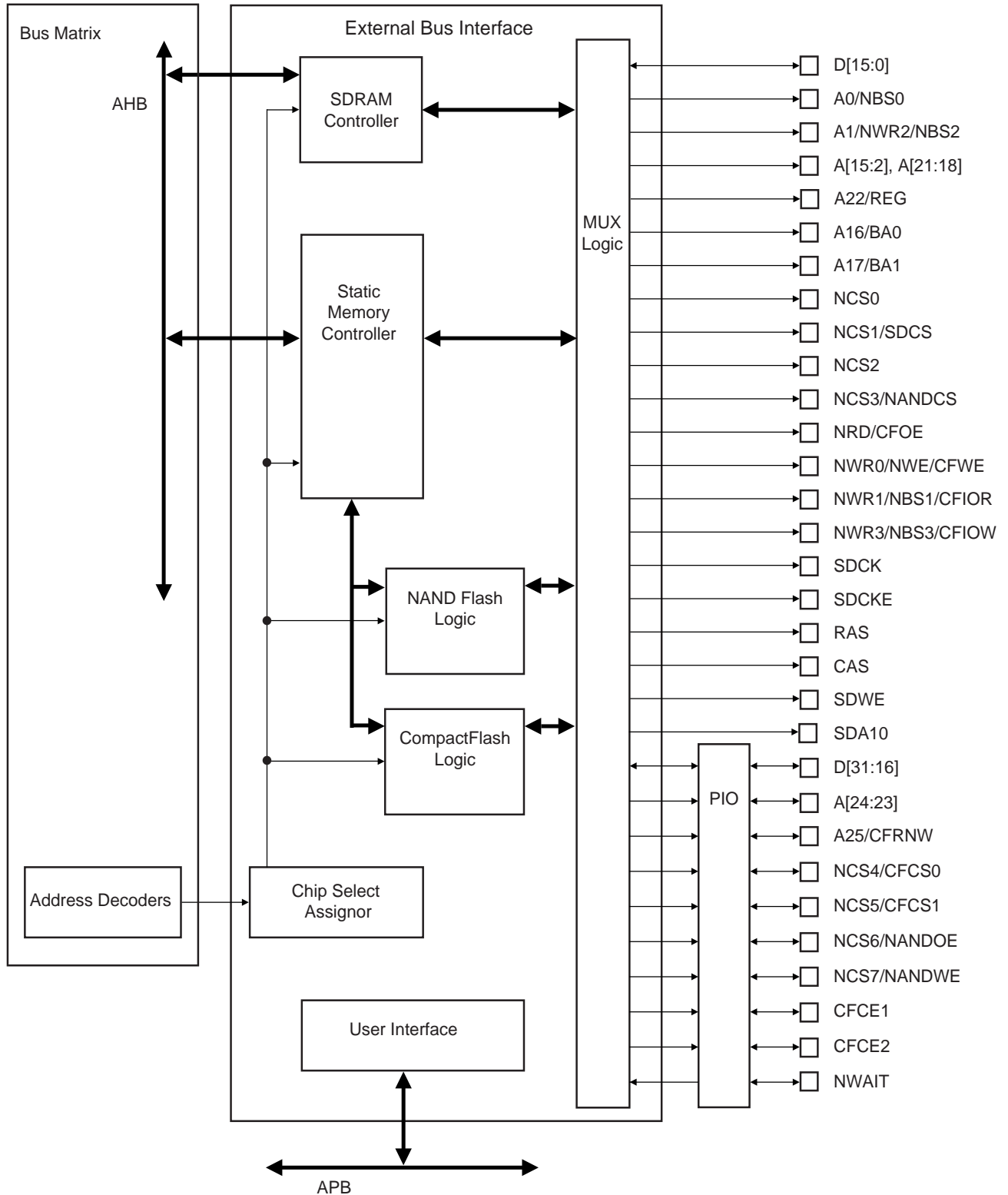

19.3 I/O Lines Description

Table 19-1. I/O Lines Description

| Name | Function | Type | Active Level |
|-------------------------------------|------------------------------------|--------|--------------|
| EBI | | | |
| D0–D31 | Data Bus | I/O | |
| A0–A25 | Address Bus | Output | |
| NWAIT | External Wait Signal | Input | Low |
| SMC | | | |
| NCS0–NCS7 | Chip Select Lines | Output | Low |
| NWR0–NWR3 | Write Signals | Output | Low |
| NRD | Read Signal | Output | Low |
| NWE | Write Enable | Output | Low |
| NBS0–NBS3 | Byte Mask Signals | Output | Low |
| EBI for CompactFlash Support | | | |
| CFCE1–CFCE2 | CompactFlash Chip Enable | Output | Low |
| CFOE | CompactFlash Output Enable | Output | Low |
| CFWE | CompactFlash Write Enable | Output | Low |
| CFIOR | CompactFlash I/O Read Signal | Output | Low |
| CFIOW | CompactFlash I/O Write Signal | Output | Low |
| CFRNW | CompactFlash Read Not Write Signal | Output | |
| CFCS0–CFCS1 | CompactFlash Chip Select Lines | Output | Low |
| EBI for NAND Flash Support | | | |
| NANDCS | NAND Flash Chip Select Line | Output | Low |
| NANDOE | NAND Flash Output Enable | Output | Low |
| NANDWE | NAND Flash Write Enable | Output | Low |
| SDRAM Controller | | | |
| SDCK | SDRAM Clock | Output | |
| SDCKE | SDRAM Clock Enable | Output | High |
| SDCS | SDRAM Controller Chip Select Line | Output | Low |
| BA0–BA1 | Bank Select | Output | |
| SDWE | SDRAM Write Enable | Output | Low |
| RAS - CAS | Row and Column Signal | Output | Low |
| NWR0–NWR3 | Write Signals | Output | Low |
| NBS0–NBS3 | Byte Mask Signals | Output | Low |
| SDA10 | SDRAM Address 10 Line | Output | |

The connection of some signals through the MUX logic is not direct and depends on the Memory Controller in use at the moment.

[Table 19-2 on page 134](#) details the connections between the two Memory Controllers and the EBI pins.

Table 19-2. EBI Pins and Memory Controllers I/O Lines Connections

| EBI Pins | SDRAMC I/O Lines | SMC I/O Lines |
|-----------------|------------------|---------------|
| NWR1/NBS1/CFIOR | NBS1 | NWR1/NUB |
| A0/NBS0 | Not Supported | SMC_A0/NLB |
| A1/NBS2/NWR2 | Not Supported | SMC_A1 |
| A[11:2] | SDRAMC_A[9:0] | SMC_A[11:2] |
| SDA10 | SDRAMC_A10 | Not Supported |
| A12 | Not Supported | SMC_A12 |
| A[14:13] | SDRAMC_A[12:11] | SMC_A[14:13] |
| A[25:15] | Not Supported | SMC_A[25:15] |
| D[31:16] | D[31:16] | D[31:16] |
| D[15:0] | D[15:0] | D[15:0] |

19.4 Application Example

19.4.1 Hardware Interface

Table 19-3 and Table 19-4 detail the connections to be applied between the EBI pins and the external devices for each Memory Controller.

Table 19-3. EBI Pins and External Static Devices Connections

| Pins | Pins of the SMC Interfaced Device | | | | | |
|--------------|-----------------------------------|--------------------------|----------------------|--------------------------|---------------------------|----------------------|
| | 8-bit Static Device | 2 x 8-bit Static Devices | 16-bit Static Device | 4 x 8-bit Static Devices | 2 x 16-bit Static Devices | 32-bit Static Device |
| D0–D7 | D0–D7 | D0–D7 | D0–D7 | D0–D7 | D0–D7 | D0–D7 |
| D8–D15 | – | D8–D15 | D8–D15 | D8–D15 | D8–15 | D8–15 |
| D16–D23 | – | – | – | D16–D23 | D16–D23 | D16–D23 |
| D24–D31 | – | – | – | D24–D31 | D24–D31 | D24–D31 |
| A0/NBS0 | A0 | – | NLB | – | NLB ⁽³⁾ | BE0 ⁽⁵⁾ |
| A1/NWR2/NBS2 | A1 | A0 | A0 | WE ⁽²⁾ | NLB ⁽⁴⁾ | BE2 ⁽⁵⁾ |
| A2–A25 | A[2:25] | A[1:24] | A[1:24] | A[0:23] | A[0:23] | A[0:23] |
| NCS0 | CS | CS | CS | CS | CS | CS |
| NCS1/SDCS | CS | CS | CS | CS | CS | CS |
| NCS2 | CS | CS | CS | CS | CS | CS |
| NCS3/NANDCS | CS | CS | CS | CS | CS | CS |
| NCS4/CFCS0 | CS | CS | CS | CS | CS | CS |
| NCS5/CFCS1 | CS | CS | CS | CS | CS | CS |
| NCS6/NANDOE | CS | CS | CS | CS | CS | CS |
| NCS7/NANDWE | CS | CS | CS | CS | CS | CS |
| NRD/CFOE | OE | OE | OE | OE | OE | OE |

Table 19-3. EBI Pins and External Static Devices Connections (Continued)

| Pins | Pins of the SMC Interfaced Device | | | | | |
|-----------|-----------------------------------|--------------------------|----------------------|--------------------------|---------------------------|----------------------|
| | 8-bit Static Device | 2 x 8-bit Static Devices | 16-bit Static Device | 4 x 8-bit Static Devices | 2 x 16-bit Static Devices | 32-bit Static Device |
| NWR0/NWE | WE | WE ⁽¹⁾ | WE | WE ⁽²⁾ | WE | WE |
| NWR1/NBS1 | – | WE ⁽¹⁾ | NUB | WE ⁽²⁾ | NUB ⁽³⁾ | BE1 ⁽⁵⁾ |
| NWR3/NBS3 | – | – | – | WE ⁽²⁾ | NUB ⁽⁴⁾ | BE3 ⁽⁵⁾ |

- Notes:
1. NWR1 enables upper byte writes. NWR0 enables lower byte writes.
 2. NWRx enables corresponding byte x writes. (x = 0, 1, 2 or 3)
 3. NBS0 and NBS1 enable respectively lower and upper bytes of the lower 16-bit word.
 4. NBS2 and NBS3 enable respectively lower and upper bytes of the upper 16-bit word.
 5. BEx: Byte x Enable (x = 0,1,2 or 3)

Table 19-4. EBI Pins and External Devices Connections

| Pins | Pins of the Interfaced Device | | | |
|--------------|-------------------------------|----------------------|----------------------------|-------------------|
| | SDRAMC | SMC | | |
| | SDRAM | CompactFlash | CompactFlash True IDE Mode | NAND Flash |
| D0–D7 | D0–D7 | D0–D7 | D0–D7 | I/O0-I/O7 |
| D8–D15 | D8–D15 | D8–15 | D8–15 | I/O8-I/O15 |
| D16–D31 | D16–D31 | – | – | – |
| A0/NBS0 | DQM0 | A0 | A0 | – |
| A1/NWR2/NBS2 | DQM2 | A1 | A1 | – |
| A2–A10 | A[0:8] | A[2:10] | A[2:10] | – |
| A11 | A9 | – | – | – |
| SDA10 | A10 | – | – | – |
| A12 | – | – | – | – |
| A13–A14 | A[11:12] | – | – | – |
| A15 | – | – | – | – |
| A16/BA0 | BA0 | – | – | – |
| A17/BA1 | BA1 | – | – | – |
| A18–A20 | – | – | – | – |
| A21 | – | – | – | CLE |
| A22 | – | REG | REG | ALE |
| A23–A24 | – | – | – | – |
| A25 | – | CFRNW ⁽¹⁾ | CFRNW ⁽¹⁾ | – |
| NCS0 | – | – | – | – |
| NCS1/SDCS | CS | – | – | – |
| NCS2 | – | – | – | – |
| NCS3/NANDCS | – | – | – | CE ⁽³⁾ |
| NCS4/CFCS0 | – | CFCS0 ⁽¹⁾ | CFCS0 ⁽¹⁾ | – |

Table 19-4. EBI Pins and External Devices Connections (Continued)

| Pins | Pins of the Interfaced Device | | | |
|--------------------|-------------------------------|----------------------|----------------------------|-------------------|
| | SDRAMC | SMC | | |
| | SDRAM | CompactFlash | CompactFlash True IDE Mode | NAND Flash |
| NCS5/CFCS1 | – | CFCS1 ⁽¹⁾ | CFCS1 ⁽¹⁾ | – |
| NCS6/NANDOE | – | – | – | RE |
| NCS7/NANDWE | – | – | – | WE |
| NRD/CFOE | – | OE | – | – |
| NWR0/NWE/CFWE | – | WE | WE | – |
| NWR1/NBS1/CFIOR | DQM1 | IOR | IOR | – |
| NWR3/NBS3/CFIOW | DQM3 | IOW | IOW | – |
| CFCE1 | – | CE1 | CS0 | – |
| CFCE2 | – | CE2 | CS1 | – |
| SDCK | CLK | – | – | – |
| SDCKE | CKE | – | – | – |
| RAS | RAS | – | – | – |
| CAS | CAS | – | – | – |
| SDWE | WE | – | – | – |
| NWAIT | – | WAIT | WAIT | – |
| Pxx ⁽²⁾ | – | CD1 or CD2 | CD1 or CD2 | – |
| Pxx ⁽²⁾ | – | – | – | CE ⁽³⁾ |
| Pxx ⁽²⁾ | – | – | – | RDY |

- Notes:
1. Not directly connected to the CompactFlash slot. Permits the control of the bidirectional buffer between the EBI data bus and the CompactFlash slot.
 2. Any PIO line.
 3. CE connection depends on the NAND Flash. For standard NAND Flash devices, it must be connected to any free PIO line. For "CE don't care" NAND Flash devices, it can be connected to either NCS3/NANDCS or to any free PIO line.

19.4.2 Connection Examples

Figure 19-2 shows an example of connections between the EBI and external devices.

Figure 19-2. EBI Connections to Memory Devices

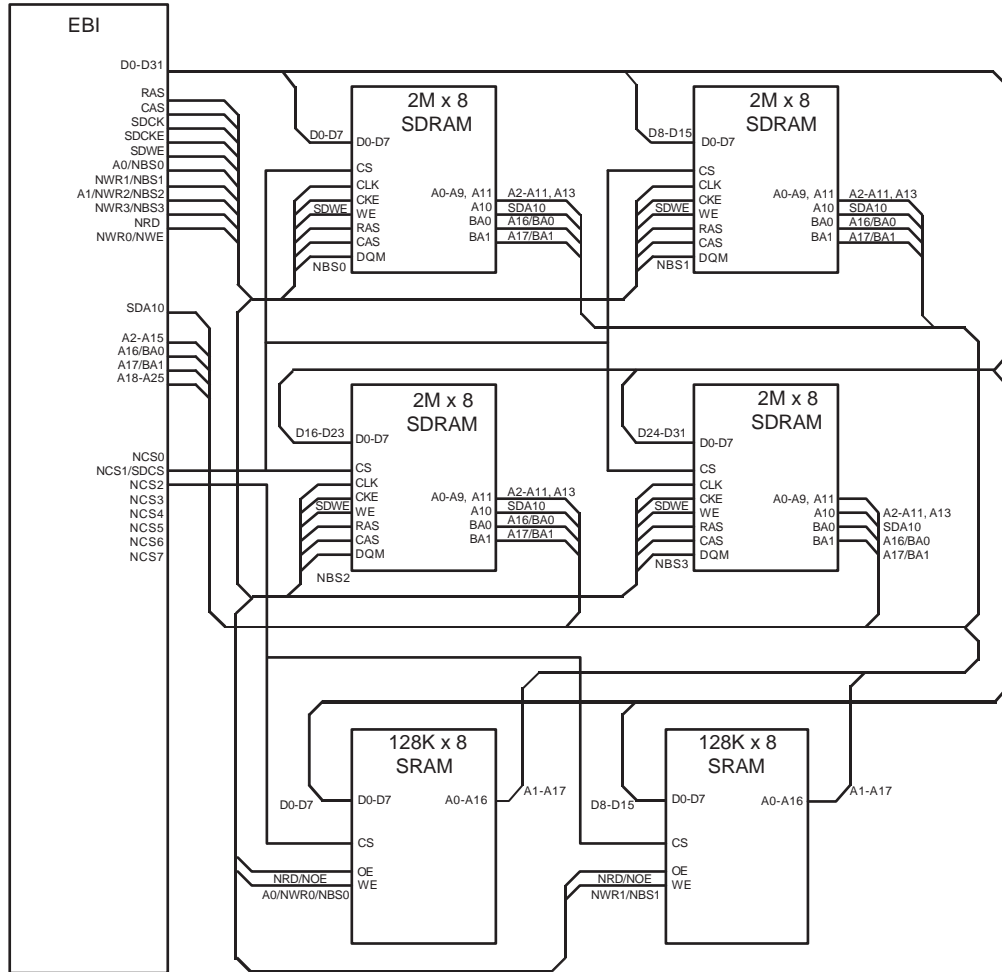

19.5 Product Dependencies

19.5.1 I/O Lines

The pins used for interfacing the External Bus Interface may be multiplexed with the PIO lines. The programmer must first program the PIO controller to assign the External Bus Interface pins to their peripheral function. If I/O lines of the External Bus Interface are not used by the application, they can be used for other purposes by the PIO Controller.

19.6 Functional Description

The EBI transfers data between the internal AHB Bus (handled by the Bus Matrix) and the external memories or peripheral devices. It controls the waveforms and the parameters of the external address, data and control busses and is composed of the following elements:

- Static Memory Controller (SMC)
- SDRAM Controller (SDRAMC)
- A chip select assignment feature that assigns an AHB address space to the external devices
- A multiplex controller circuit that shares the pins between the different Memory Controllers
- Programmable CompactFlash support logic
- Programmable NAND Flash support logic

19.6.1 Bus Multiplexing

The EBI offers a complete set of control signals that share the 32-bit data lines, the address lines of up to 26 bits and the control signals through a multiplex logic operating in function of the memory area requests.

Multiplexing is specifically organized in order to guarantee the maintenance of the address and output control lines at a stable state while no external access is being performed. Multiplexing is also designed to respect the data float times defined in the Memory Controllers. Furthermore, refresh cycles of the SDRAM are executed independently by the SDRAM Controller without delaying the other external Memory Controller accesses.

19.6.2 Pull-up Control

The [EBI Chip Select Assignment Register](#) (EBI_CSA) in the Bus Matrix User Interface permits enabling of on-chip pull-up resistors on the data bus lines not multiplexed with the PIO Controller lines. The pull-up resistors are enabled after reset. Setting the EBI_CSA.EBI_DBPUC bit disables the pull-up resistors on the lines D0–D15. Enabling the pull-up resistor on the lines D16–D31 can be performed by programming the appropriate PIO controller.

19.6.3 Static Memory Controller

For information on the Static Memory Controller, refer to [Section 20. “Static Memory Controller \(SMC\)”](#).

19.6.4 SDRAM Controller

For information on the SDRAM Controller, refer to [Section 21. “SDRAM Controller \(SDRAMC\)”](#).

19.6.5 CompactFlash Support

The External Bus Interface integrates circuitry that interfaces to CompactFlash devices.

The CompactFlash logic is driven by the Static Memory Controller (SMC) on the NCS4 and/or NCS5 address space. Programming the EBI_CS4A and/or EBI_CS5A bit(s) of the [EBI Chip Select Assignment Register](#) to the appropriate value enables this logic. Access to an external CompactFlash device is then made by accessing the address space reserved to NCS4 and/or NCS5 (i.e., between 0x5000 0000 and 0x5FFF FFFF for NCS4 and between 0x6000 0000 and 0x6FFF FFFF for NCS5).

All CompactFlash modes (Attribute Memory, Common Memory, I/O and True IDE) are supported but the signals `_IOIS16` (I/O and True IDE modes) and `_ATA SEL` (True IDE mode) are not handled.

19.6.5.1 I/O Mode, Common Memory Mode, Attribute Memory Mode and True IDE Mode

Within the NCS4 and/or NCS5 address space, the current transfer address is used to distinguish I/O mode, common memory mode, attribute memory mode and True IDE mode.

The different modes are accessed through a specific memory mapping as illustrated on [Figure 19-3](#). A[23:21] bits of the transfer address are used to select the desired mode as described in [Table 19-5 on page 139](#).

Figure 19-3. CompactFlash Memory Mapping

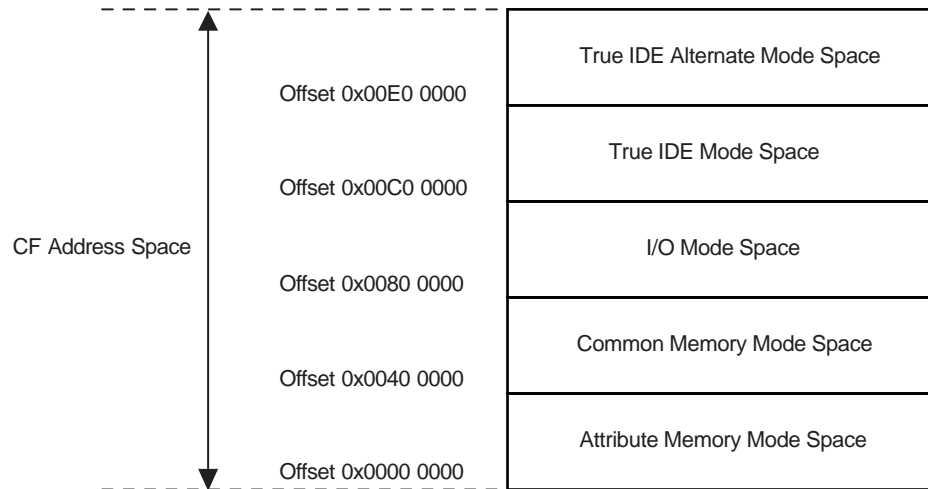

Note: The A22 pin of the EBI is used to drive the REG signal of the CompactFlash Device (except in True IDE mode).

Table 19-5. CompactFlash Mode Selection

| A[23:21] | Mode Base Address |
|----------|-------------------------|
| 000 | Attribute Memory |
| 010 | Common Memory |
| 100 | I/O Mode |
| 110 | True IDE Mode |
| 111 | Alternate True IDE Mode |

19.6.5.2 CFCE1 and CFCE2 Signals

To cover all types of access, the SMC must be alternatively set to drive 8-bit data bus or 16-bit data bus. The odd byte access on the D[7:0] bus is only possible when the SMC is configured to drive 8-bit memory devices on the corresponding NCS pin (NCS4 and or NCS5). The DBW field in the [SMC Mode Register](#) corresponding to the NCS4 and/or NCS5 address space must be set as shown in [Table 19-6](#) to enable the required access type.

NBS1 and NBS0 are the byte selection signals from SMC and are available when the SMC is set in Byte Select mode on the corresponding Chip Select.

The CFCE1 and CFCE2 waveforms are identical to the corresponding NCSx waveform. For details on these waveforms and timings, refer to [Section 20. "Static Memory Controller \(SMC\)"](#).

Table 19-6. CFCE1 and CFCE2 Truth Table

| Mode | CFCE2 | CFCE1 | DBW | Comment | SMC Access Mode |
|---|-------|-------|------------|--|-----------------|
| Attribute Memory | NBS1 | NBS0 | 16 bits | Access to Even Byte on D[7:0] | Byte Select |
| Common Memory | NBS1 | NBS0 | 16bits | Access to Even Byte on D[7:0] Access to Odd Byte on D[15:8] | Byte Select |
| | 1 | 0 | 8 bits | Access to Odd Byte on D[7:0] | Don't Care |
| I/O Mode | NBS1 | NBS0 | 16 bits | Access to Even Byte on D[7:0] Access to Odd Byte on D[15:8] | Byte Select |
| | 1 | 0 | 8 bits | Access to Odd Byte on D[7:0] | Don't Care |
| True IDE Mode | | | | | |
| Task File | 1 | 0 | 8 bits | Access to Even Byte on D[7:0] Access to Odd Byte on D[7:0] | Don't Care |
| Data Register | 1 | 0 | 16 bits | Access to Even Byte on D[7:0] Access to Odd Byte on D[15:8] | Byte Select |
| Alternate True IDE Mode | | | | | |
| Control Register Alternate Status Read | 0 | 1 | Don't Care | Access to Even Byte on D[7:0] | Don't Care |
| Drive Address | 0 | 1 | 8 bits | Access to Odd Byte on D[7:0] | Don't Care |
| True IDE Standby Mode or Address Space is not assigned to CF | 1 | 1 | Don't Care | Don't Care | Don't Care |

19.6.5.3 Read/Write Signals

In I/O mode and True IDE mode, the CompactFlash logic drives the read and write command signals of the SMC on CFIOR and CFIOW signals, while the CFOE and CFWE signals are deactivated. Likewise, in common memory mode and attribute memory mode, the SMC signals are driven on the CFOE and CFWE signals, while the CFIOR and CFIOW are deactivated. Figure 19-4 demonstrates a schematic representation of this logic.

Attribute memory mode, common memory mode and I/O mode are supported by setting the address setup and hold time on the NCS4 (and/or NCS5) chip select to the appropriate values.

Figure 19-4. CompactFlash Read/Write Control Signals

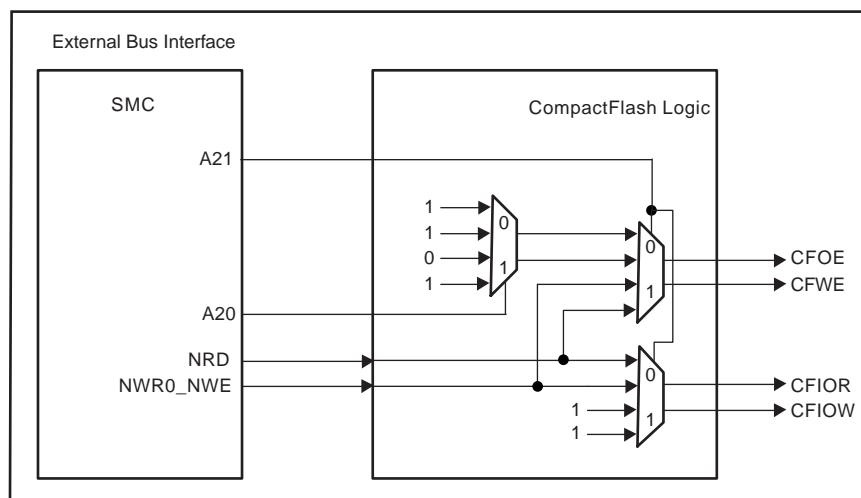

Table 19-7. CompactFlash Mode Selection

| Mode Base Address | CFOE | CFWE | CFIOR | CFIOW |
|-----------------------------------|------|----------|-------|----------|
| Attribute Memory Common Memory | NRD | NWR0_NWE | 1 | 1 |
| I/O Mode | 1 | 1 | NRD | NWR0_NWE |
| True IDE Mode | 0 | 1 | NRD | NWR0_NWE |

19.6.5.4 Multiplexing of CompactFlash Signals on EBI Pins

Table 19-8 and Table 19-9 illustrate the multiplexing of the CompactFlash logic signals with other EBI signals on the EBI pins. The EBI pins in Table 19-8 are strictly dedicated to the CompactFlash interface as soon as the EBI_CS4A and/or EBI_CS5A bit(s) of the [EBI Chip Select Assignment Register](#) is set. These pins must not be used to drive any other memory devices.

The EBI pins in Table 19-9 remain shared between all memory areas when the corresponding CompactFlash interface is enabled (CS4A = 1 and/or CS5A = 1).

Table 19-8. Dedicated CompactFlash Interface Multiplexing

| Pins | CompactFlash Signals | | EBI Signals | |
|------------|----------------------|----------|-------------|----------|
| | CS4A = 1 | CS5A = 1 | CS4A = 0 | CS5A = 0 |
| NCS4/CFCS0 | CFCS0 | | NCS4 | |
| NCS5/CFCS1 | | CFCS1 | | NCS5 |

Table 19-9. Shared CompactFlash Interface Multiplexing

| Pins | Access to CompactFlash Device | Access to Other EBI Devices |
|-----------------|-------------------------------|-----------------------------|
| | CompactFlash Signals | EBI Signals |
| NRD/CFOE | CFOE | NRD |
| NWR0/NWE/CFWE | CFWE | NWR0/NWE |
| NWR1/NBS1/CFIOR | CFIOR | NWR1/NBS1 |
| NWR3/NBS3/CFIOW | CFIOW | NWR3/NBS3 |
| A25/CFRNW | CFRNW | A25 |

19.6.5.5 Application Example

Figure 19-5 on page 142 illustrates an example of a CompactFlash application. CFCS0 and CFRNW signals are not directly connected to the CompactFlash slot 0, but do control the direction and the output enable of the buffers between the EBI and the CompactFlash Device. The timing of the CFCS0 signal is identical to the NCS4 signal. Moreover, the CFRNW signal remains valid throughout the transfer, as does the address bus. The CompactFlash _WAIT signal is connected to the NWAIT input of the Static Memory Controller. For details on these waveforms and timings, refer to [Section 20. "Static Memory Controller \(SMC\)"](#).

Figure 19-5. CompactFlash Application Example

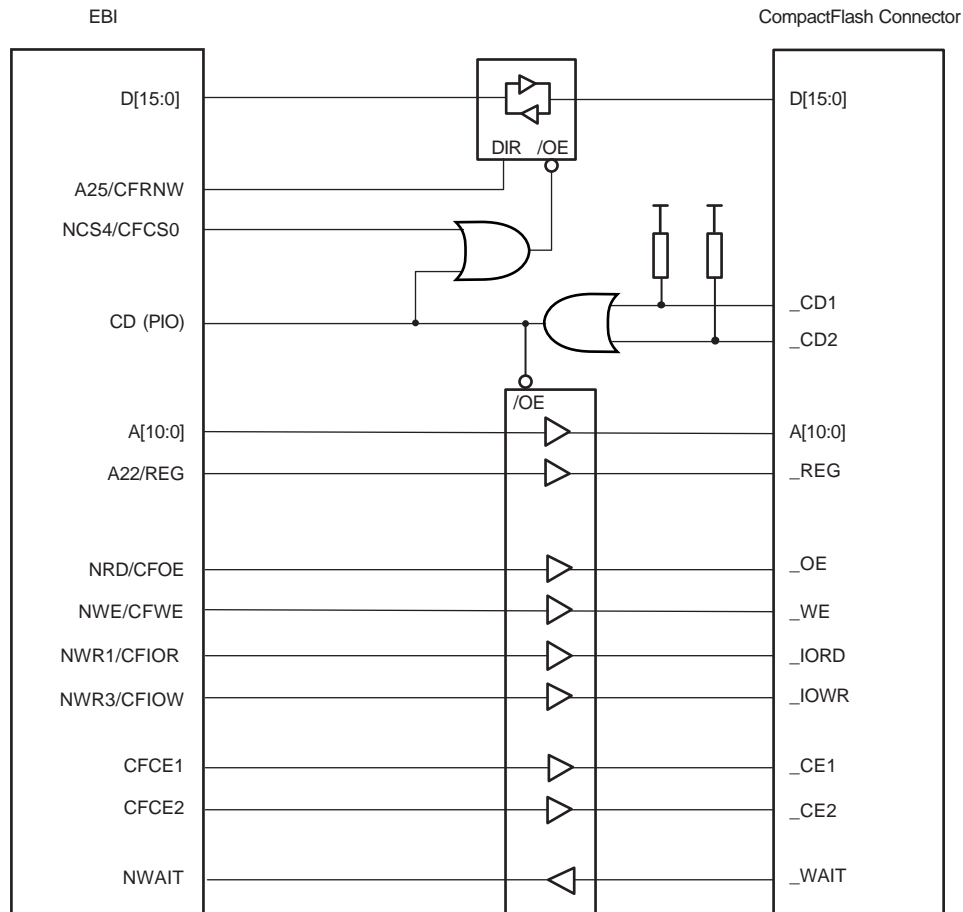

19.6.6 NAND Flash Support

The EBI integrates circuitry that interfaces to NAND Flash devices.

The NAND Flash logic is driven by the Static Memory Controller on the NCS3 address space. Programming the EBI_CS3A bit in the [EBI Chip Select Assignment Register](#) to the appropriate value enables the NAND Flash logic. Access to an external NAND Flash device is then made by accessing the address space reserved to NCS3 (i.e., between 0x40000000 and 0x4FFF FFFF).

The NAND Flash Logic drives the read and write command signals of the SMC on the NANDOE and NANDWE signals when the NCS3 signal is active. NANDOE and NANDWE are invalidated as soon as the transfer address fails to lie in the NCS3 address space. For details on these waveforms, refer to [Section 20. "Static Memory Controller \(SMC\)"](#).

The NANDOE and NANDWE signals are multiplexed with NCS6 and NCS7 signals of the Static Memory Controller. This multiplexing is controlled in the MUX logic part of the EBI by the EBI_CS3A bit in the [EBI Chip Select Assignment Register](#). NCS6 and NCS7 become unavailable. Performing an access within the address space reserved to NCS6 and NCS7 (i.e., between 0x70000000 and 0x8FFF FFFF) may lead to an unpredictable outcome.

Figure 19-6. NAND Flash Signal Multiplexing on EBI Pins

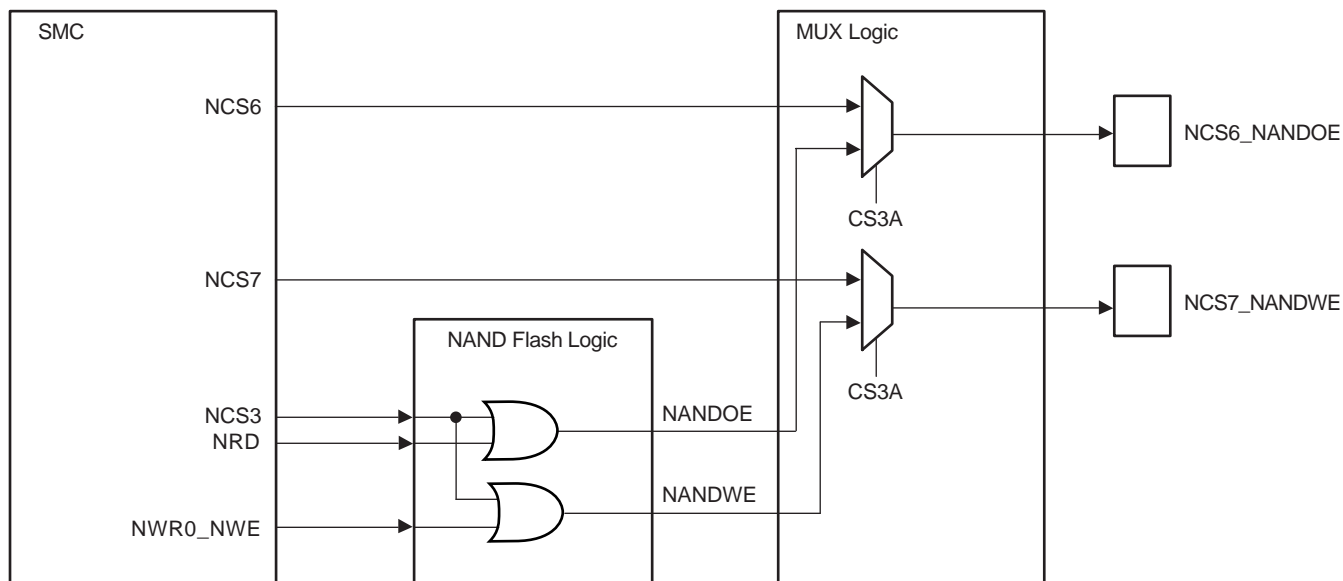

The address latch enable and command latch enable signals on the NAND Flash device are driven by address bits A22 and A21 of the EBI address bus. The user should note that any bit on the EBI address bus can also be used for this purpose. The command, address or data words on the data bus of the NAND Flash device are distinguished by using their address within the NCS3 address space. The chip enable (CE) signal of the device and the ready/busy (R/B) signals are connected to PIO lines. The CE signal then remains asserted even when NCS3 is not selected, preventing the device from returning to standby mode.

Figure 19-7. NAND Flash Application Example

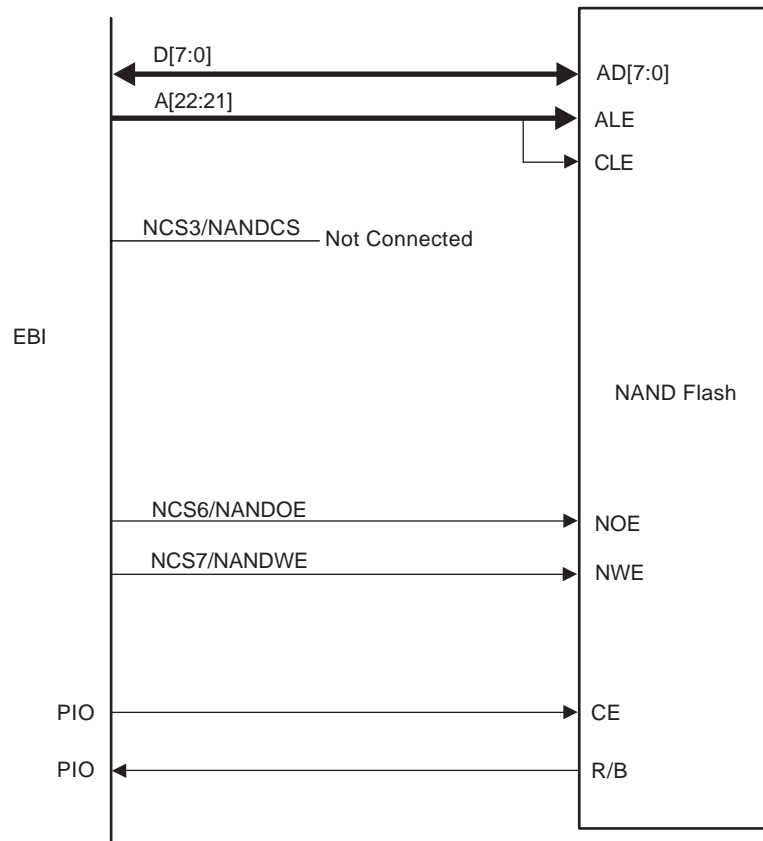

Note: The External Bus Interface is also able to support 16-bit devices.

19.7 Implementation Examples

All the hardware configurations are given for illustration only. The user should refer to the memory manufacturer web site to check the device availability.

19.7.1 16-bit SDRAM

19.7.1.1 Hardware Configuration

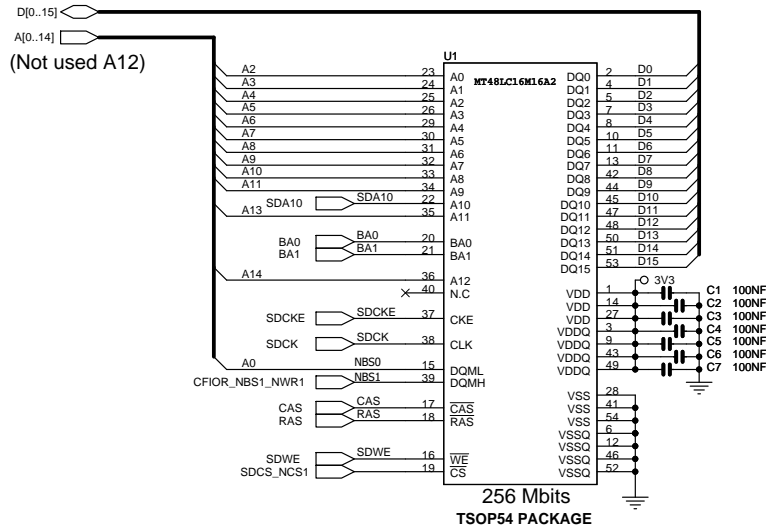

19.7.1.2 Software Configuration

The following configuration has to be performed:

- Assign the EBI CS1 to the SDRAM controller by setting the bit EBI_CS1A in the [EBI Chip Select Assignment Register](#) located in the bus matrix memory space.
- Initialize the SDRAM Controller depending on the SDRAM device and system bus frequency.

The Data Bus Width is to be programmed to 16 bits.

The SDRAM initialization sequence is described in [Section 21.4.1 "SDRAM Device Initialization"](#).

19.7.2 32-bit SDRAM

19.7.2.1 Hardware Configuration

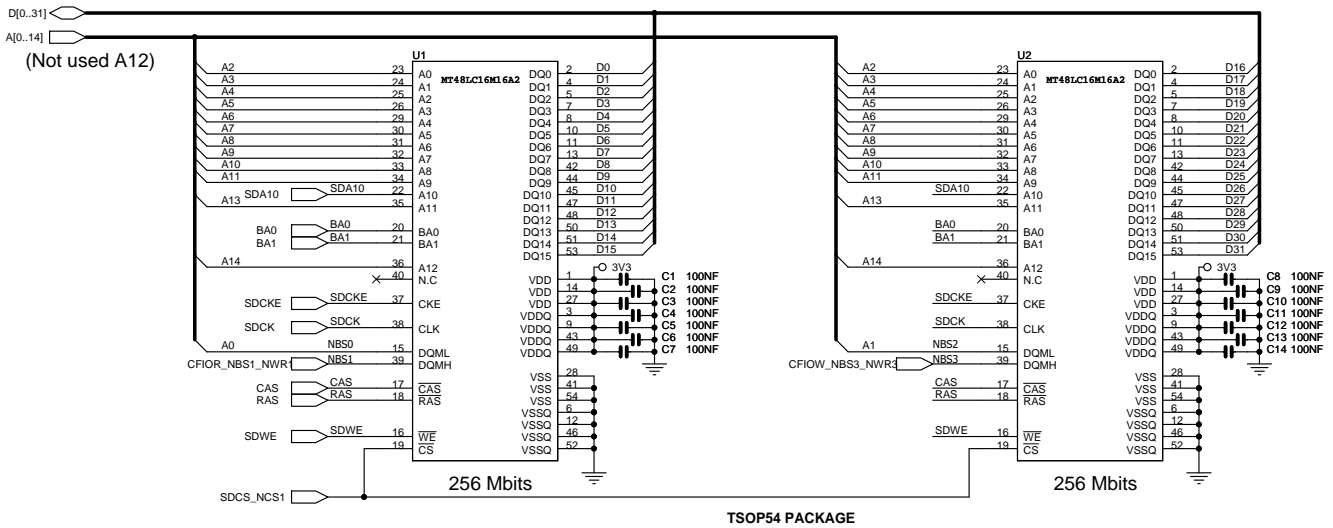

19.7.2.2 Software Configuration

The following configuration has to be performed:

- Assign the EBI CS1 to the SDRAM controller by setting the bit EBI_CS1A in the [EBI Chip Select Assignment Register](#) located in the bus matrix memory space.
- Initialize the SDRAM Controller depending on the SDRAM device and system bus frequency.

The Data Bus Width is to be programmed to 32 bits. The data lines D[16..31] are multiplexed with PIO lines and thus the dedicated PIOs must be programmed in peripheral mode in the PIO controller.

The SDRAM initialization sequence is described in [Section 21.4.1 "SDRAM Device Initialization"](#).

19.7.3 8-bit NAND Flash

19.7.3.1 Hardware Configuration

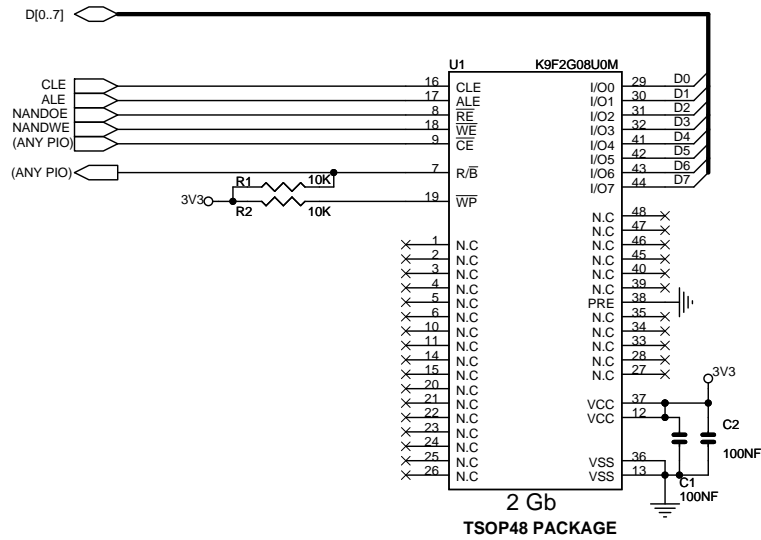

19.7.3.2 Software Configuration

The following configuration has to be performed:

- Assign the EBI CS3 to the NAND Flash by setting the bit EBI_CS3A in the [EBI Chip Select Assignment Register](#) located in the bus matrix memory space
- Reserve A21 / A22 for ALE / CLE functions. Address and Command Latches are controlled respectively by setting to 1 the address bit A21 and A22 during accesses.
- NANDOE and NANDWE signals are multiplexed with PIO lines and thus the dedicated PIOs must be programmed in peripheral mode in the PIO controller.
- Configure a PIO line as an input to manage the Ready/Busy signal.
- Configure Static Memory Controller CS3 Setup, Pulse, Cycle and Mode accordingly to NAND Flash timings, the data bus width and the system bus frequency.

19.7.4 16-bit NAND Flash

19.7.4.1 Hardware Configuration

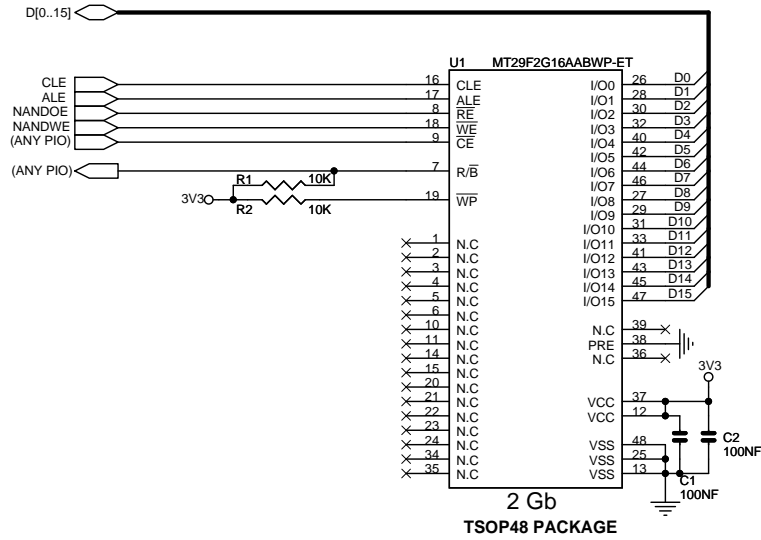

19.7.4.2 Software Configuration

The software configuration is the same as for an 8-bit NAND Flash except the data bus width programmed in the mode register of the Static Memory Controller.

19.7.5 NOR Flash on NCS0

19.7.5.1 Hardware Configuration

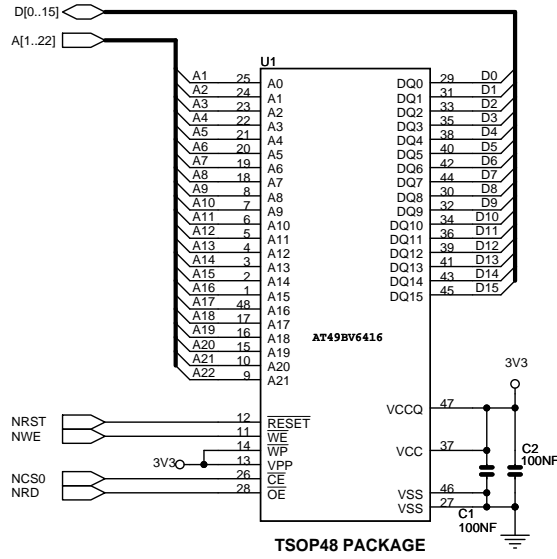

19.7.5.2 Software Configuration

The default configuration for the Static Memory Controller, byte select mode, 16-bit data bus, Read/Write controlled by Chip Select, allows boot on 16-bit non-volatile memory at slow clock.

For another configuration, configure the Static Memory Controller CS0 Setup, Pulse, Cycle and Mode depending on Flash timings and system bus frequency.

19.7.6.1 Software Configuration

The following configuration has to be performed:

- Assign the EBI CS4 and/or EBI CS5 to the CompactFlash Slot 0 or/and Slot 1 by setting the EBI_CS4A or/and EBI_CS5A bit(s) in the [EBI Chip Select Assignment Register](#) located in the bus matrix memory space.
- The address line A23 is to select I/O (A23=1) or Memory mode (A23=0) and the address line A22 for REG function.
- A23, CFRNW, CFS0, CFCS1, CFCE1 and CFCE2 signals are multiplexed with PIO lines and thus the dedicated PIOs must be programmed in peripheral mode in the PIO controller.
- Configure a PIO line as an output for CFRST and two others as an input for CFIRQ and CARD DETECT functions respectively.
- Configure SMC CS4 and/or SMC_CS5 (for Slot 0 or 1) Setup, Pulse, Cycle and Mode accordingly to Compact Flash timings and system bus frequency.

19.7.7 Compact Flash True IDE

Figure 19-9. Hardware Configuration

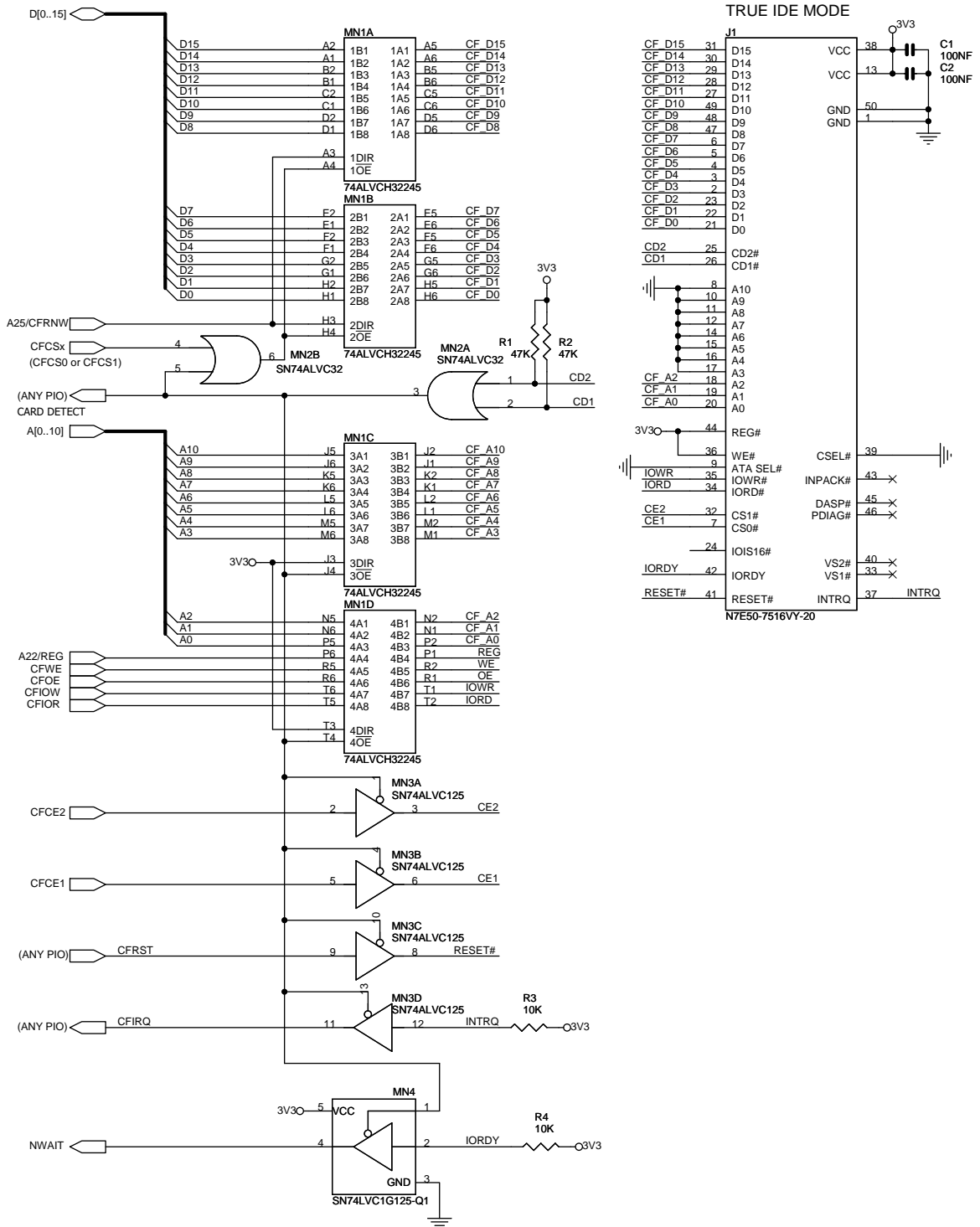

19.7.7.1 Software Configuration

The following configuration has to be performed:

- Assign the EBI CS4 and/or EBI CS5 to the CompactFlash Slot 0 or/and Slot 1 by setting the EBI_CS4A or/and EBI_CS5A bit(s) in the [EBI Chip Select Assignment Register](#) located in the bus matrix memory space.
- The address line A21 is to select Alternate True IDE (A21=1) or True IDE (A21=0) modes.
- CFRNW, CFS0, CFCS1, CFCE1 and CFCE2 signals are multiplexed with PIO lines and thus the dedicated PIOs must be programmed in peripheral mode in the PIO controller.
- Configure a PIO line as an output for CFRST and two others as an input for CFIRQ and CARD DETECT functions respectively.
- Configure SMC CS4 and/or SMC_CS5 (for Slot 0 or 1) Setup, Pulse, Cycle and Mode accordingly to Compact Flash timings and system bus frequency.

20. Static Memory Controller (SMC)

20.1 Overview

The Static Memory Controller (SMC) generates the signals that control the access to the external memory devices or peripheral devices. It has 8 Chip Selects and a 26-bit address bus. The 32-bit data bus can be configured to interface with 8-, 16-, or 32-bit external devices. Separate read and write control signals allow for direct memory and peripheral interfacing. Read and write signal waveforms are fully parametrizable.

The SMC can manage wait requests from external devices to extend the current access. The SMC is provided with an automatic slow clock mode. In slow clock mode, it switches from user-programmed waveforms to slow-rate specific waveforms on read and write signals. The SMC supports asynchronous burst read in page mode access for page size up to 32 bytes.

20.2 I/O Lines Description

Table 20-1. I/O Line Description

| Name | Description | Type | Active Level |
|--------------|--|--------|--------------|
| NCS[7:0] | Static Memory Controller Chip Select Lines | Output | Low |
| NRD | Read Signal | Output | Low |
| NWR0/NWE | Write 0/Write Enable Signal | Output | Low |
| A0/NBS0 | Address Bit 0/Byte 0 Select Signal | Output | Low |
| NWR1/NBS1 | Write 1/Byte 1 Select Signal | Output | Low |
| A1/NWR2/NBS2 | Address Bit 1/Write 2/Byte 2 Select Signal | Output | Low |
| NWR3/NBS3 | Write 3/Byte 3 Select Signal | Output | Low |
| A[25:2] | Address Bus | Output | – |
| D[31:0] | Data Bus | I/O | – |
| NWAIT | External Wait Signal | Input | Low |

20.3 Multiplexed Signals

Table 20-2. Static Memory Controller (SMC) Multiplexed Signals

| Multiplexed Signals | | | Related Function |
|---------------------|------|------|--|
| NWR0 | NWE | | Byte-write or byte-select access, see “Byte Write or Byte Select Access” on page 157 |
| A0 | NBS0 | | 8-bit or 16-/32-bit data bus, see “Data Bus Width” on page 157 |
| NWR1 | NBS1 | | Byte-write or byte-select access see “Byte Write or Byte Select Access” on page 157 |
| A1 | NWR2 | NBS2 | 8-/16-bit or 32-bit data bus, see “Data Bus Width” on page 157 . Byte-write or byte-select access, see “Byte Write or Byte Select Access” on page 157 |
| NWR3 | NBS3 | | Byte-write or byte-select access see “Byte Write or Byte Select Access” on page 157 |

20.4 Application Example

20.4.1 Hardware Interface

Figure 20-1. SMC Connections to Static Memory Devices

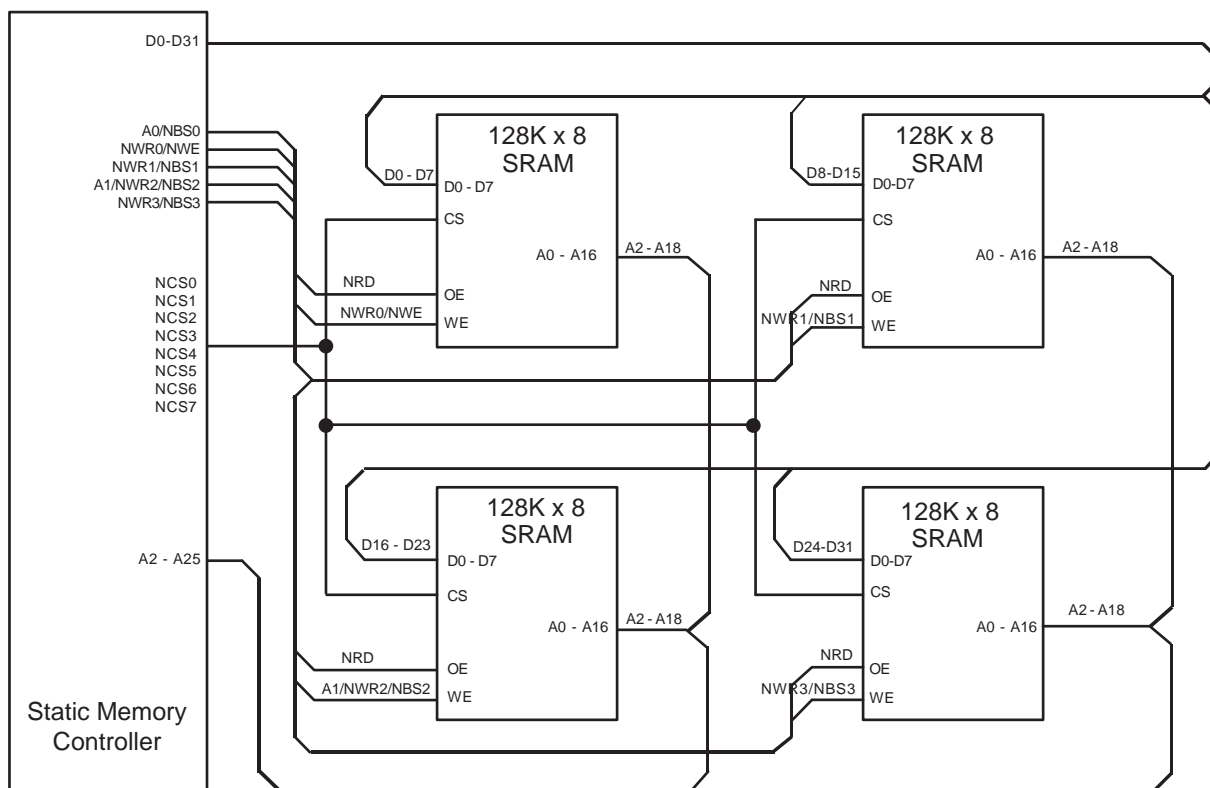

20.5 Product Dependencies

20.5.1 I/O Lines

The pins used for interfacing the Static Memory Controller may be multiplexed with the PIO lines. The programmer must first program the PIO controller to assign the Static Memory Controller pins to their peripheral function. If I/O Lines of the SMC are not used by the application, they can be used for other purposes by the PIO Controller.

20.6 External Memory Mapping

The SMC provides up to 26 address lines, A[25:0]. This allows each chip select line to address up to 64 Mbytes of memory.

If the physical memory device connected on one chip select is smaller than 64 Mbytes, it wraps around and appears to be repeated within this space. The SMC correctly handles any valid access to the memory device within the page (see [Figure 20-2](#)).

A[25:0] is only significant for 8-bit memory, A[25:1] is used for 16-bit memory, A[25:2] is used for 32-bit memory.

Figure 20-2. Memory Connections for Eight External Devices

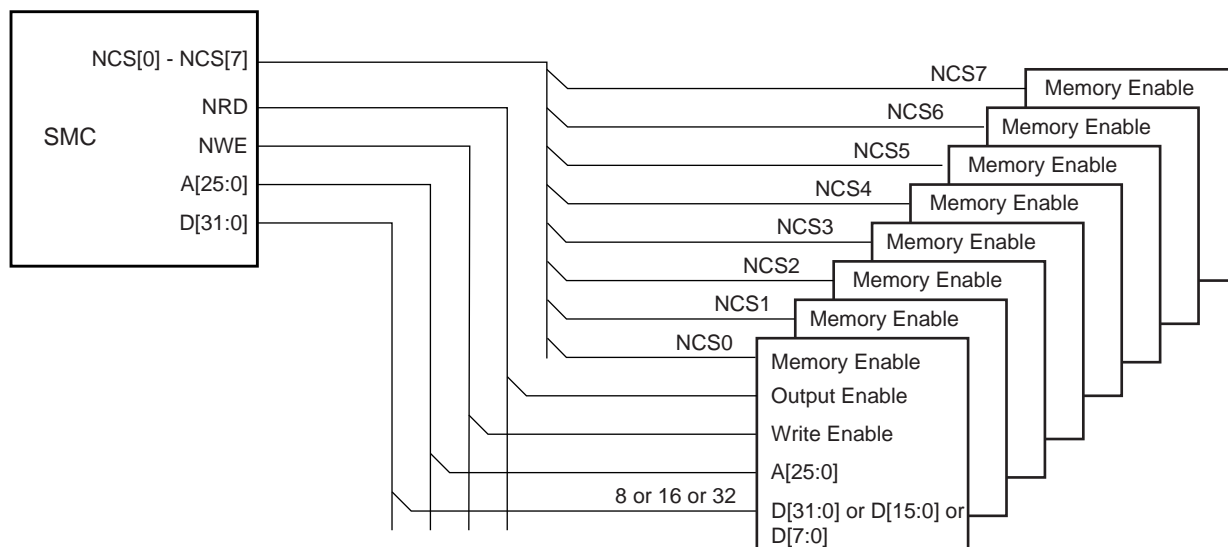

20.7 Connection to External Devices

20.7.1 Data Bus Width

A data bus width of 8, 16, or 32 bits can be selected for each chip select. This option is controlled by the field DBW in SMC_MODE (Mode Register) for the corresponding chip select.

Figure 20-3 shows how to connect a 512K x 8-bit memory on NCS2. Figure 20-4 shows how to connect a 512K x 16-bit memory on NCS2. Figure 20-5 shows two 16-bit memories connected as a single 32-bit memory

20.7.2 Byte Write or Byte Select Access

Each chip select with a 16-bit or 32-bit data bus can operate with one of two different types of write access: byte write or byte select access. This is controlled by the field SMC_MODE.BAT for the corresponding chip select.

Figure 20-3. Memory Connection for an 8-bit Data Bus

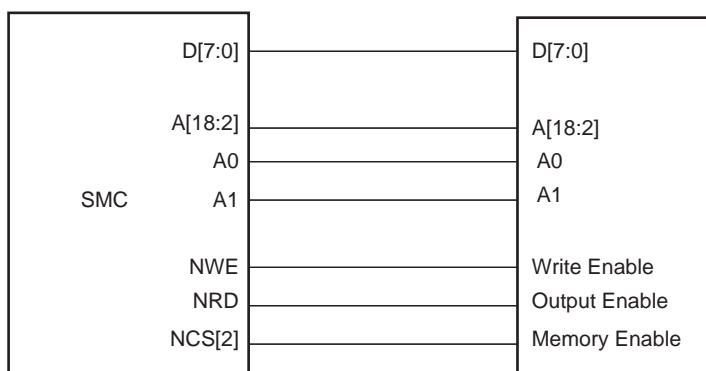

Figure 20-4. Memory Connection for a 16-bit Data Bus

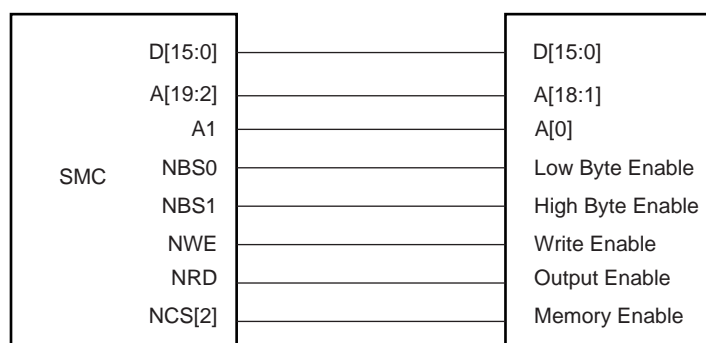
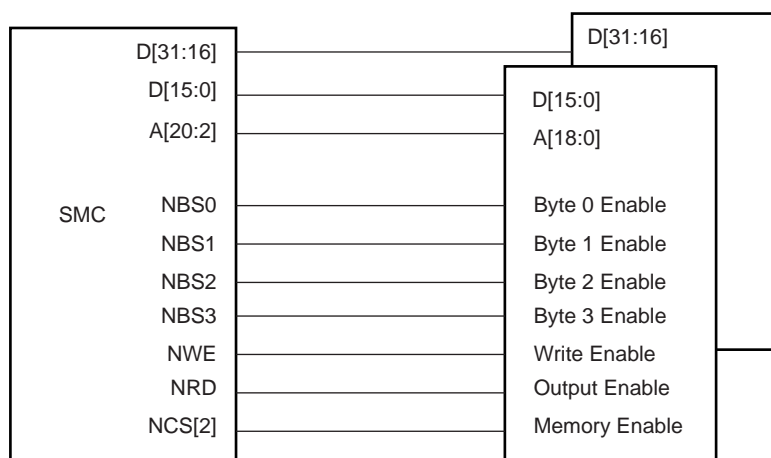

Figure 20-5. Memory Connection for a 32-bit Data Bus



20.7.2.1 Byte Write Access

Byte write access supports one byte write signal per byte of the data bus and a single read signal.

Note that the SMC does not allow boot in Byte Write Access mode.

- For 16-bit devices: the SMC provides NWR0 and NWR1 write signals for respectively byte0 (lower byte) and byte1 (upper byte) of a 16-bit bus. One single read signal (NRD) is provided.

Byte Write Access is used to connect 2 x 8-bit devices as a 16-bit memory.

- For 32-bit devices: NWR0, NWR1, NWR2 and NWR3, are the write signals of byte0 (lower byte), byte1, byte2 and byte 3 (upper byte) respectively. One single read signal (NRD) is provided.

Byte Write Access is used to connect 4 x 8-bit devices as a 32-bit memory.

Byte Write option is illustrated on [Figure 20.7.2.3](#).

Figure 20-6. Connection of 2 x 8-bit Devices on a 16-bit Bus: Byte Write Option

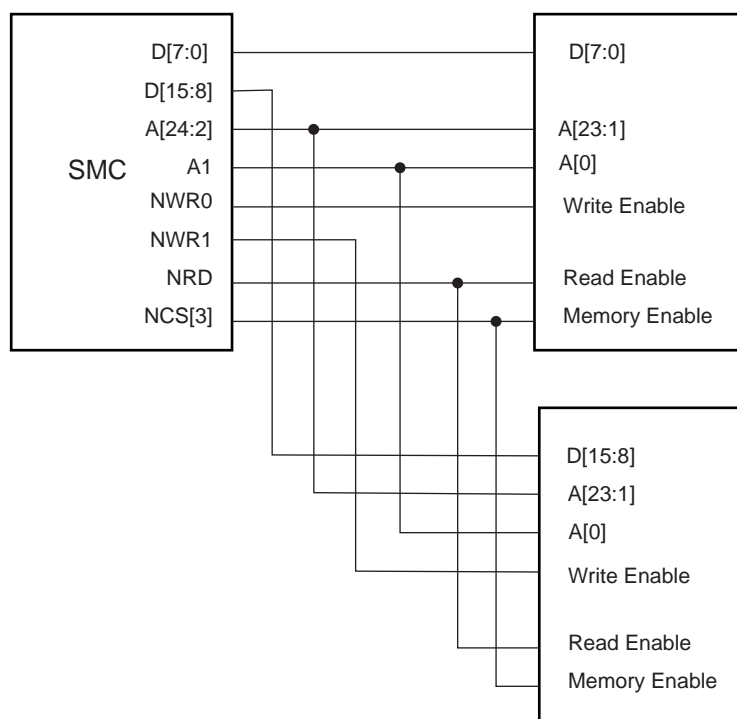

20.7.2.2 Byte Select Access

In this mode, read/write operations can be enabled/disabled at a byte level. One byte-select line per byte of the data bus is provided. One NRD and one NWE signal control read and write.

- For 16-bit devices: the SMC provides NBS0 and NBS1 selection signals for respectively byte0 (lower byte) and byte1 (upper byte) of a 16-bit bus.

Byte Select Access is used to connect one 16-bit device.

- For 32-bit devices: NBS0, NBS1, NBS2 and NBS3, are the selection signals of byte0 (lower byte), byte1, byte2 and byte 3 (upper byte) respectively. Byte Select Access is used to connect two 16-bit devices.

[Figure](#) shows how to connect two 16-bit devices on a 32-bit data bus in Byte Select Access mode, on NCS3 (BAT = Byte Select Access).

Figure 20-7. Connection of 2x16-bit Data Bus on a 32-bit Data Bus (Byte Select Option)

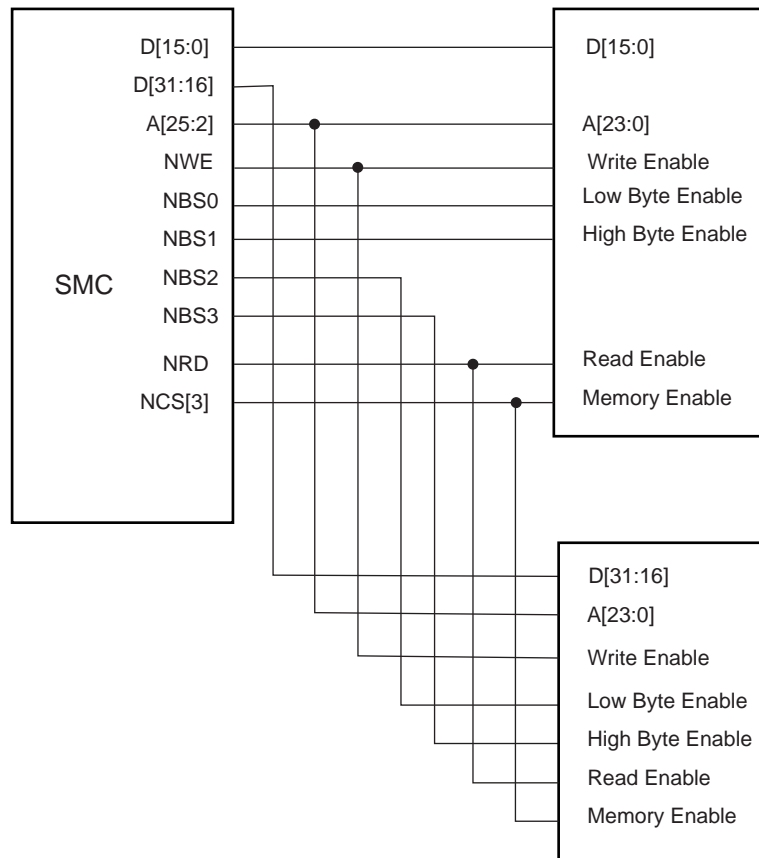

20.7.2.3 Signal Multiplexing

Depending on the BAT, only the write signals or the byte select signals are used. To save IOs at the external bus interface, control signals at the SMC interface are multiplexed. Table 20-3 shows signal multiplexing depending on the data bus width and the byte access type.

For 32-bit devices, bits A0 and A1 are unused. For 16-bit devices, bit A0 of address is unused. When Byte Select Option is selected, NWR1 to NWR3 are unused. When Byte Write option is selected, NBS0 to NBS3 are unused.

Table 20-3. SMC Multiplexed Signal Translation

| Signal Name | 32-bit Bus | | | 16-bit Bus | | 8-bit Bus |
|------------------------|-------------|-------------|------------|-------------|------------|-----------|
| | 1x32-bit | 2x16-bit | 4 x 8-bit | 1x16-bit | 2 x 8-bit | 1 x 8-bit |
| Byte Access Type (BAT) | Byte Select | Byte Select | Byte Write | Byte Select | Byte Write | |
| NBS0_A0 | NBS0 | NBS0 | | NBS0 | | A0 |
| NWE_NWR0 | NWE | NWE | NWR0 | NWE | NWR0 | NWE |
| NBS1_NWR1 | NBS1 | NBS1 | NWR1 | NBS1 | NWR1 | |
| NBS2_NWR2_A1 | NBS2 | NBS2 | NWR2 | A1 | A1 | A1 |
| NBS3_NWR3 | NBS3 | NBS3 | NWR3 | | | |

20.8 Standard Read and Write Protocols

In the following sections, the byte access type is not considered. Byte select lines (NBS0 to NBS3) always have the same timing as the A address bus. NWE represents either the NWE signal in byte select access type or one of the byte write lines (NWR0 to NWR3) in byte write access type. NWR0 to NWR3 have the same timings and protocol as NWE. In the same way, NCS represents one of the NCS[0..7] chip select lines.

20.8.1 Read Waveforms

The read cycle is shown on [Figure 20-8](#).

The read cycle starts with the address setting on the memory address bus, i.e.:

{A[25:2], A1, A0} for 8-bit devices

{A[25:2], A1} for 16-bit devices

A[25:2] for 32-bit devices.

Figure 20-8. Standard Read Cycle

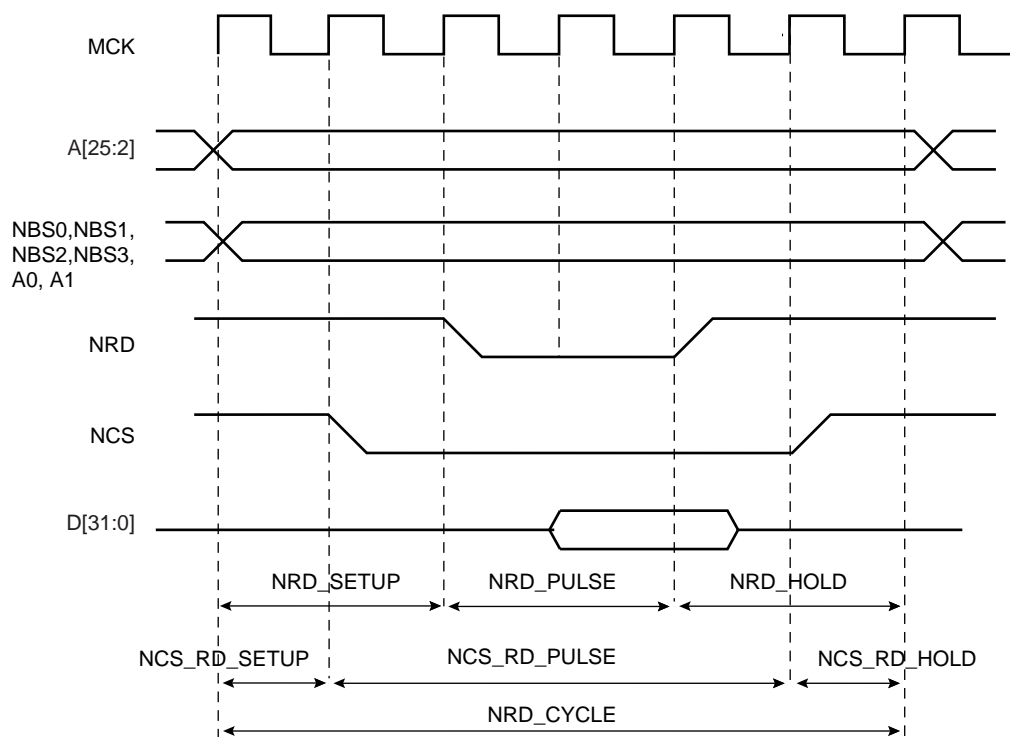

20.8.1.1 NRD Waveform

The NRD signal is characterized by a setup timing, a pulse width and a hold timing.

1. NRD_SETUP: the NRD setup time is defined as the setup of address before the NRD falling edge;
2. NRD_PULSE: the NRD pulse length is the time between NRD falling edge and NRD rising edge;
3. NRD_HOLD: the NRD hold time is defined as the hold time of address after the NRD rising edge.

20.8.1.2 NCS Waveform

Similarly, the NCS signal can be divided into a setup time, pulse length and hold time:

1. NCS_RD_SETUP: the NCS setup time is defined as the setup time of address before the NCS falling edge.
2. NCS_RD_PULSE: the NCS pulse length is the time between NCS falling edge and NCS rising edge;
3. NCS_RD_HOLD: the NCS hold time is defined as the hold time of address after the NCS rising edge.

20.8.1.3 Read Cycle

The NRD_CYCLE time is defined as the total duration of the read cycle, i.e., from the time where address is set on the address bus to the point where address may change. The total read cycle time is equal to:

$$\text{NRD_CYCLE} = \text{NRD_SETUP} + \text{NRD_PULSE} + \text{NRD_HOLD},$$

as well as

$$\text{NRD_CYCLE} = \text{NCS_RD_SETUP} + \text{NCS_RD_PULSE} + \text{NCS_RD_HOLD}$$

All NRD and NCS timings are defined separately for each chip select as an integer number of Master Clock cycles. The NRD_CYCLE field is common to both the NRD and NCS signals, thus the timing period is of the same duration.

NRD_CYCLE, NRD_SETUP, and NRD_PULSE implicitly define the NRD_HOLD value as:

$$\text{NRD_HOLD} = \text{NRD_CYCLE} - \text{NRD_SETUP} - \text{NRD_PULSE}$$

NRD_CYCLE, NCS_RD_SETUP, and NCS_RD_PULSE implicitly define the NCS_RD_HOLD value as:

$$\text{NCS_RD_HOLD} = \text{NRD_CYCLE} - \text{NCS_RD_SETUP} - \text{NCS_RD_PULSE}$$

20.8.1.4 Null Delay Setup and Hold

If null setup and hold parameters are programmed for NRD and/or NCS, NRD and NCS remain active continuously in case of consecutive read cycles in the same memory (see [Figure 20-9](#)).

Figure 20-9. No Setup, No Hold On NRD and NCS Read Signals

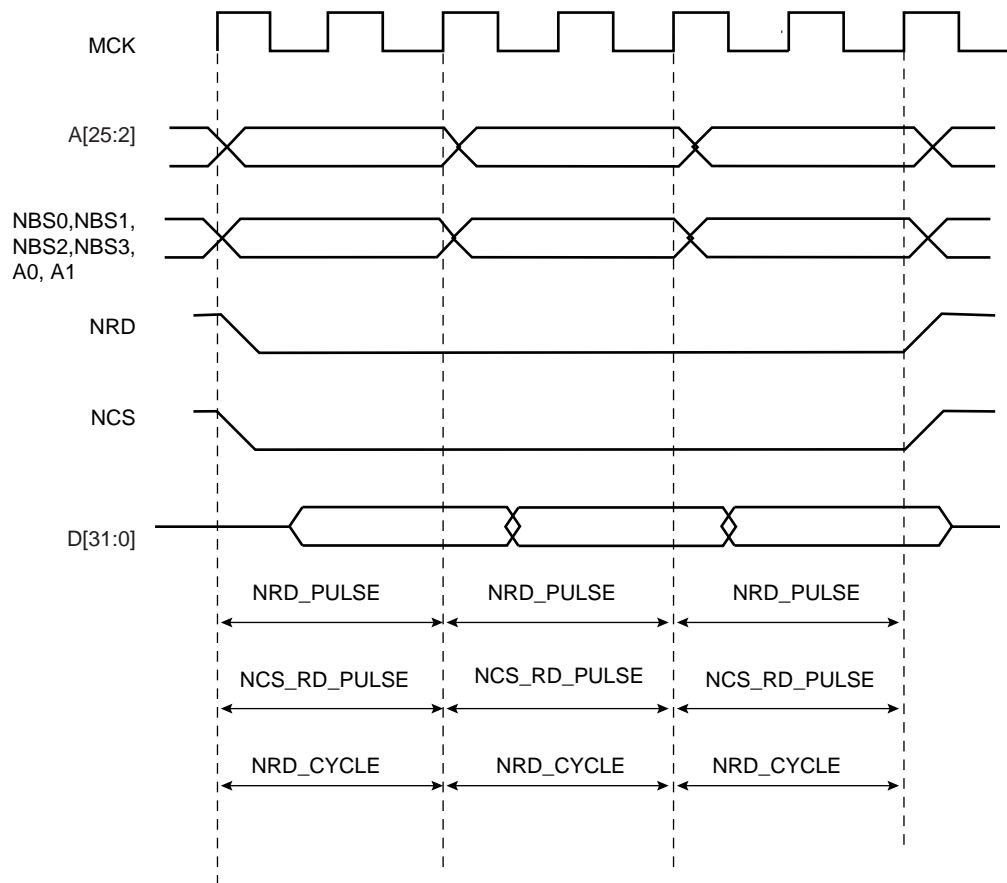

20.8.1.5 Null Pulse

Programming null pulse is not permitted. Pulse must be at least set to 1. A null value leads to unpredictable behavior.

20.8.2 Read Mode

As NCS and NRD waveforms are defined independently of one other, the SMC needs to know when the read data is available on the data bus. The SMC does not compare NCS and NRD timings to know which signal rises first. The READ_MODE parameter in the SMC_MODE register of the corresponding chip select indicates which signal of NRD and NCS controls the read operation.

20.8.2.1 Read is Controlled by NRD (READ_MODE = 1):

Figure 20-10 shows the waveforms of a read operation of a typical asynchronous RAM. The read data is available t_{PACC} after the falling edge of NRD, and turns to 'Z' after the rising edge of NRD. In this case, the READ_MODE must be set to 1 (read is controlled by NRD), to indicate that data is available with the rising edge of NRD. The SMC samples the read data internally on the rising edge of Master Clock that generates the rising edge of NRD, whatever the programmed waveform of NCS may be.

Figure 20-10. READ_MODE = 1: Data is sampled by SMC before the rising edge of NRD

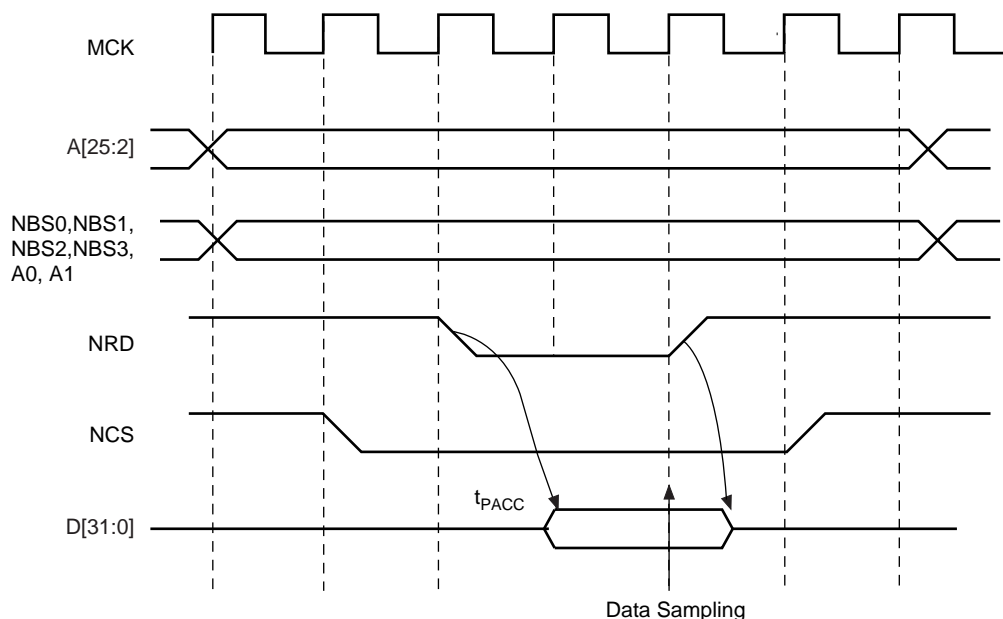

20.8.2.2 Read is Controlled by NCS (READ_MODE = 0)

Figure 20-11 shows the typical read cycle of an LCD module. The read data is valid t_{PACC} after the falling edge of the NCS signal and remains valid until the rising edge of NCS. Data must be sampled when NCS is raised. In that case, the READ_MODE must be set to 0 (read is controlled by NCS): the SMC internally samples the data on the rising edge of Master Clock that generates the rising edge of NCS, whatever the programmed waveform of NRD may be.

Figure 20-11. READ_MODE = 0: Data is sampled by SMC before the rising edge of NCS

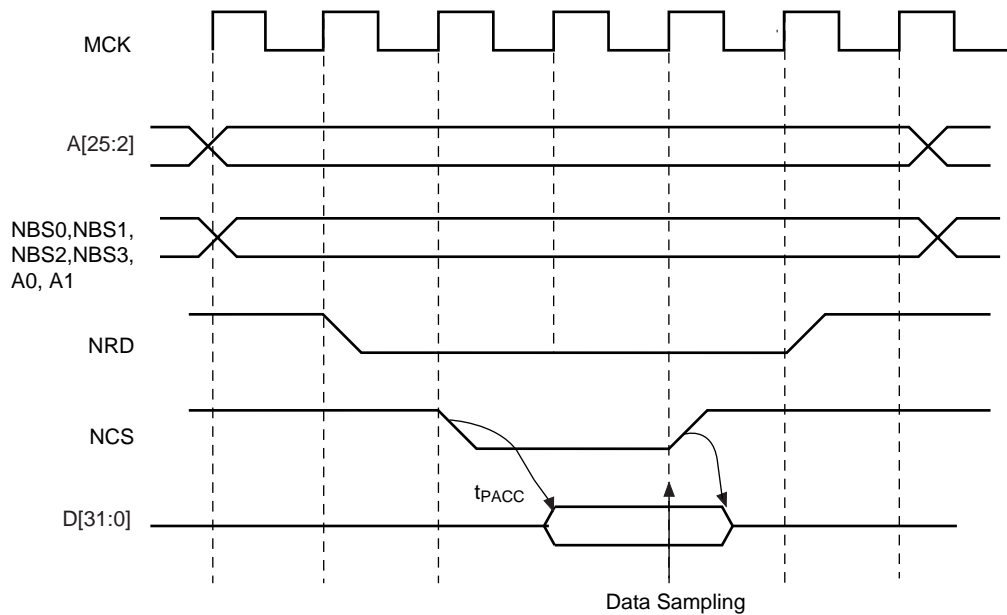

20.8.3 Write Waveforms

The write protocol is similar to the read protocol. It is depicted in [Figure 20-12](#). The write cycle starts with the address setting on the memory address bus.

20.8.3.1 NWE Waveforms

The NWE signal is characterized by a setup timing, a pulse width and a hold timing.

1. **NWE_SETUP:** the NWE setup time is defined as the setup of address and data before the NWE falling edge;
2. **NWE_PULSE:** The NWE pulse length is the time between NWE falling edge and NWE rising edge;
3. **NWE_HOLD:** The NWE hold time is defined as the hold time of address and data after the NWE rising edge.

The NWE waveforms apply to all byte-write lines in Byte Write access mode: NWR0 to NWR3.

20.8.3.2 NCS Waveforms

The NCS signal waveforms in write operation are not the same that those applied in read operations, but are separately defined:

1. **NCS_WR_SETUP:** the NCS setup time is defined as the setup time of address before the NCS falling edge.
2. **NCS_WR_PULSE:** the NCS pulse length is the time between NCS falling edge and NCS rising edge;
3. **NCS_WR_HOLD:** the NCS hold time is defined as the hold time of address after the NCS rising edge.

Figure 20-12. Write Cycle

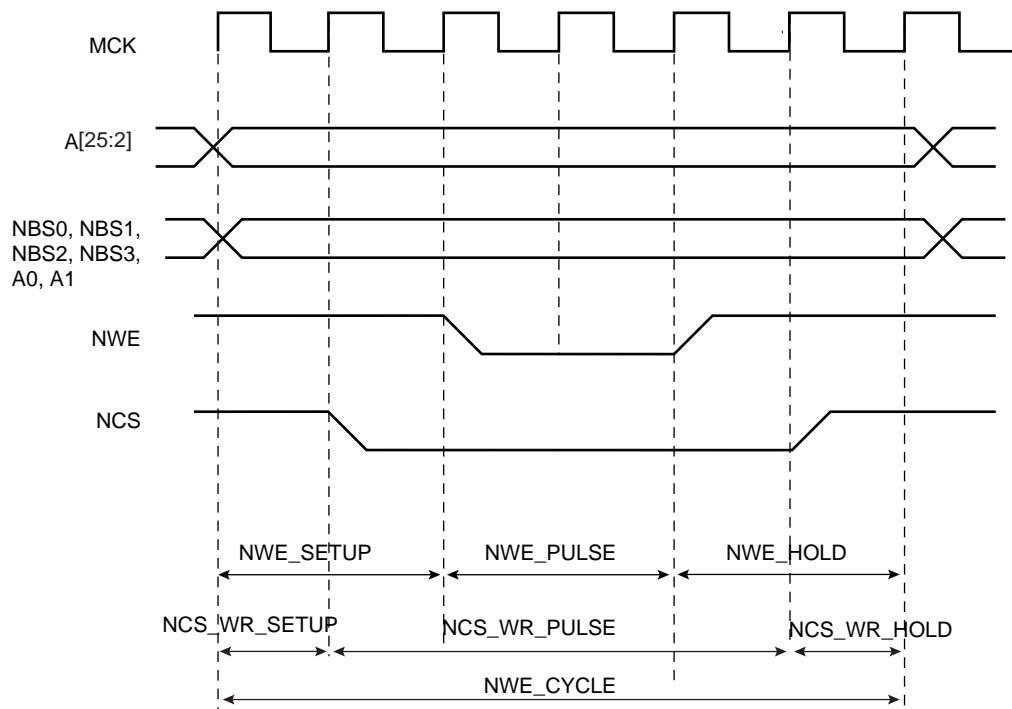

20.8.3.3 Write Cycle

The write cycle time is defined as the total duration of the write cycle, that is, from the time where address is set on the address bus to the point where address may change. The total write cycle time is equal to:

$$\text{NWE_CYCLE} = \text{NWE_SETUP} + \text{NWE_PULSE} + \text{NWE_HOLD},$$

as well as

$$\text{NWE_CYCLE} = \text{NCS_WR_SETUP} + \text{NCS_WR_PULSE} + \text{NCS_WR_HOLD}$$

All NWE and NCS (write) timings are defined separately for each chip select as an integer number of Master Clock cycles. The NWE_CYCLE field is common to both the NWE and NCS signals, thus the timing period is of the same duration.

NWE_CYCLE, NWE_SETUP, and NWE_PULSE implicitly define the NWE_HOLD value as:

$$\text{NWE_HOLD} = \text{NWE_CYCLE} - \text{NWE_SETUP} - \text{NWE_PULSE}$$

NWE_CYCLE, NCS_WR_SETUP, and NCS_WR_PULSE implicitly define the NCS_WR_HOLD value as:

$$\text{NCS_WR_HOLD} = \text{NWE_CYCLE} - \text{NCS_WR_SETUP} - \text{NCS_WR_PULSE}$$

20.8.3.4 Null Delay Setup and Hold

If null setup parameters are programmed for NWE and/or NCS, NWE and/or NCS remain active continuously in case of consecutive write cycles in the same memory (see [Figure 20-13](#)). However, for devices that perform write operations on the rising edge of NWE or NCS, such as SRAM, either a setup or a hold must be programmed.

Figure 20-13. Null Setup and Hold Values of NCS and NWE in Write Cycle

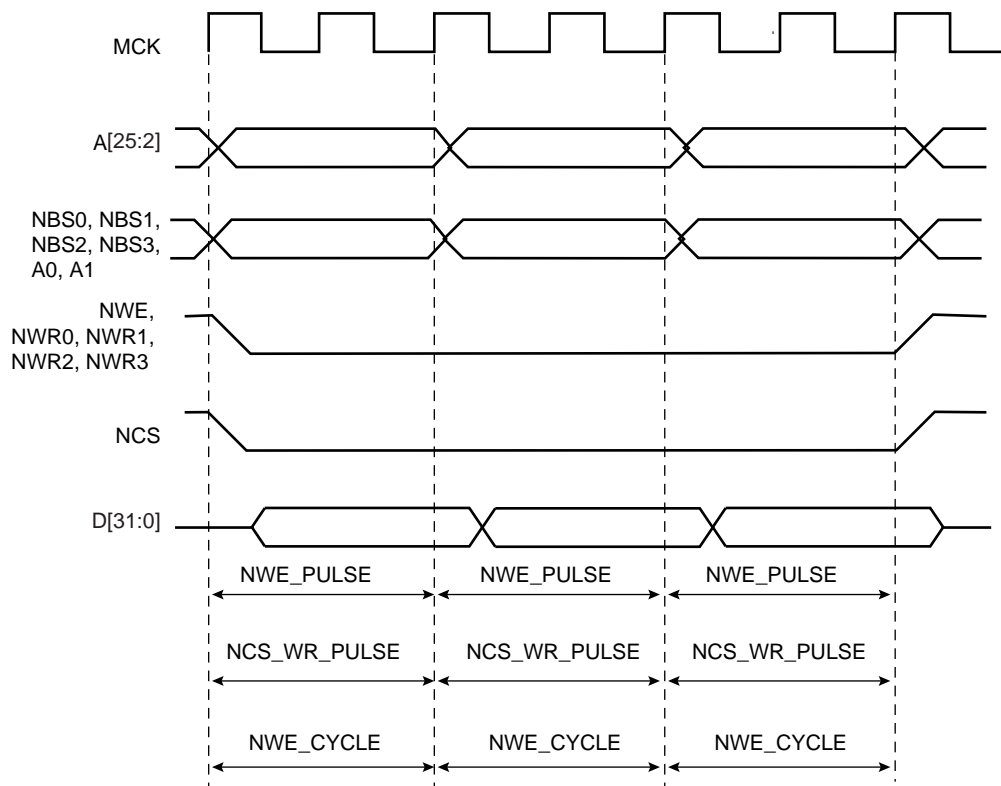

20.8.3.5 Null Pulse

Programming null pulse is not permitted. Pulse must be at least set to 1. A null value leads to unpredictable behavior.

20.8.4 Write Mode

The WRITE_MODE parameter in the SMC_MODE register of the corresponding chip select indicates which signal controls the write operation.

20.8.4.1 Write is Controlled by NWE (WRITE_MODE = 1):

Figure 20-14 shows the waveforms of a write operation with WRITE_MODE set to 1. The data is put on the bus during the pulse and hold steps of the NWE signal. The internal data buffers are turned out after the NWE_SETUP time, and until the end of the write cycle, regardless of the programmed waveform on NCS.

Figure 20-14. WRITE_MODE = 1. The write operation is controlled by NWE

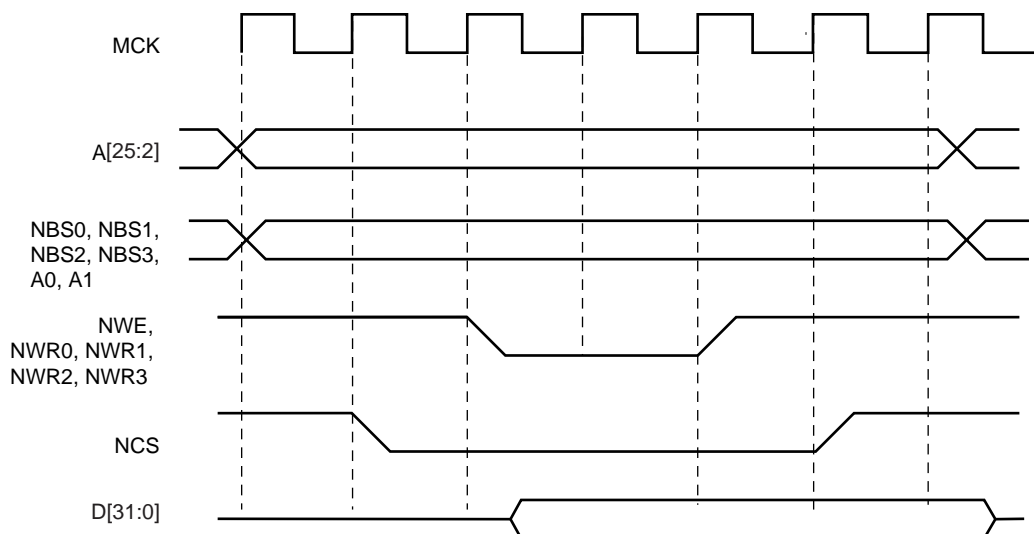

20.8.4.2 Write is Controlled by NCS (WRITE_MODE = 0)

Figure 20-15 shows the waveforms of a write operation with WRITE_MODE set to 0. The data is put on the bus during the pulse and hold steps of the NCS signal. The internal data buffers are turned out after the NCS_WR_SETUP time, and until the end of the write cycle, regardless of the programmed waveform on NWE.

Figure 20-15. WRITE_MODE = 0. The write operation is controlled by NCS

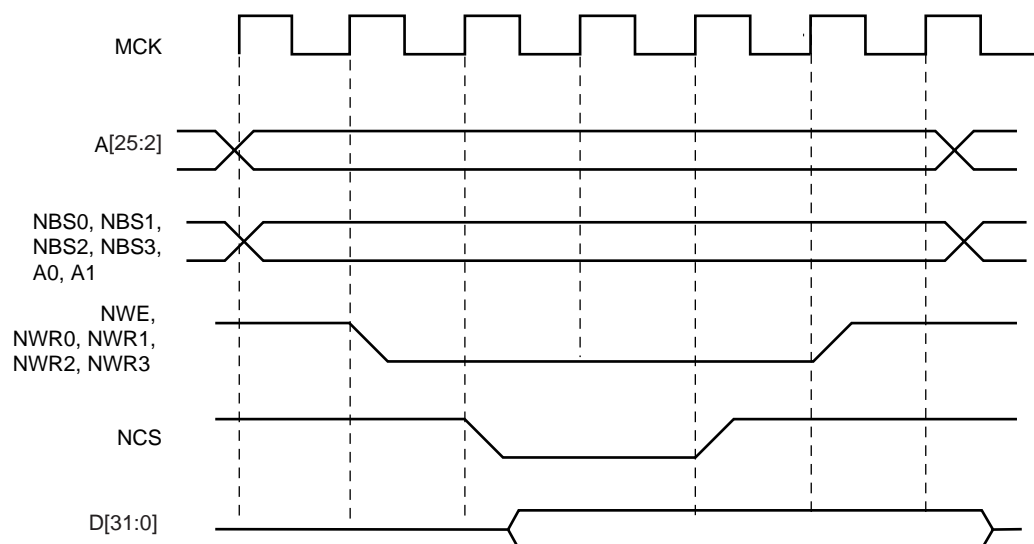

20.8.5 Coding Timing Parameters

All timing parameters are defined for one chip select and are grouped together in one SMC_REGISTER according to their type.

The SMC_SETUP register groups the definition of all setup parameters:

- NRD_SETUP, NCS_RD_SETUP, NWE_SETUP, NCS_WR_SETUP

The SMC_PULSE register groups the definition of all pulse parameters:

- NRD_PULSE, NCS_RD_PULSE, NWE_PULSE, NCS_WR_PULSE

The SMC_CYCLE register groups the definition of all cycle parameters:

- NRD_CYCLE, NWE_CYCLE

Table 20-4 shows how the timing parameters are coded and their permitted range.

Table 20-4. Coding and Range of Timing Parameters

| Coded Value | Number of Bits | Effective Value | Permitted Range | |
|-------------|----------------|--|-----------------|--|
| | | | Coded Value | Effective Value |
| setup [5:0] | 6 | $128 \times \text{setup}[5] + \text{setup}[4:0]$ | $0 \leq 31$ | $0 \leq 128 + 31$ |
| pulse [6:0] | 7 | $256 \times \text{pulse}[6] + \text{pulse}[5:0]$ | $0 \leq 63$ | $0 \leq 256 + 63$ |
| cycle [8:0] | 9 | $256 \times \text{cycle}[8:7] + \text{cycle}[6:0]$ | $0 \leq 127$ | $0 \leq 256 + 127$ $0 \leq 512 + 127$ $0 \leq 768 + 127$ |

20.8.6 Reset Values of Timing Parameters

Table 20-8, "Register Mapping," on page 187 gives the default value of timing parameters at reset.

20.8.7 Usage Restriction

The SMC does not check the validity of the user-programmed parameters. If the sum of SETUP and PULSE parameters is larger than the corresponding CYCLE parameter, this leads to unpredictable behavior of the SMC.

For read operations:

Null but positive setup and hold of address and NRD and/or NCS can not be guaranteed at the memory interface because of the propagation delay of these signals through external logic and pads. If positive setup and hold values must be verified, then it is strictly recommended to program non-null values so as to cover possible skews between address, NCS and NRD signals.

For write operations:

If a null hold value is programmed on NWE, the SMC can guarantee a positive hold of address, byte select lines, and NCS signal after the rising edge of NWE. This is true for WRITE_MODE = 1 only. See "Early Read Wait State" on page 169.

For read and write operations: a null value for pulse parameters is forbidden and may lead to unpredictable behavior.

In read and write cycles, the setup and hold time parameters are defined in reference to the address bus. For external devices that require setup and hold time between NCS and NRD signals (read), or between NCS and NWE signals (write), these setup and hold times must be converted into setup and hold times in reference to the address bus.

20.9 Automatic Wait States

Under certain circumstances, the SMC automatically inserts idle cycles between accesses to avoid bus contention or operation conflict.

20.9.1 Chip Select Wait States

The SMC always inserts an idle cycle between 2 transfers on separate chip selects. This idle cycle ensures that there is no bus contention between the de-activation of one device and the activation of the next one.

During chip select wait state, all control lines are turned inactive: NBS0 to NBS3, NWR0 to NWR3, NCS[0..7], NRD lines are all set to 1.

Figure 20-16 illustrates a chip select wait state between access on Chip Select 0 and Chip Select 2.

Figure 20-16. Chip Select Wait State between a Read Access on NCS0 and a Write Access on NCS2

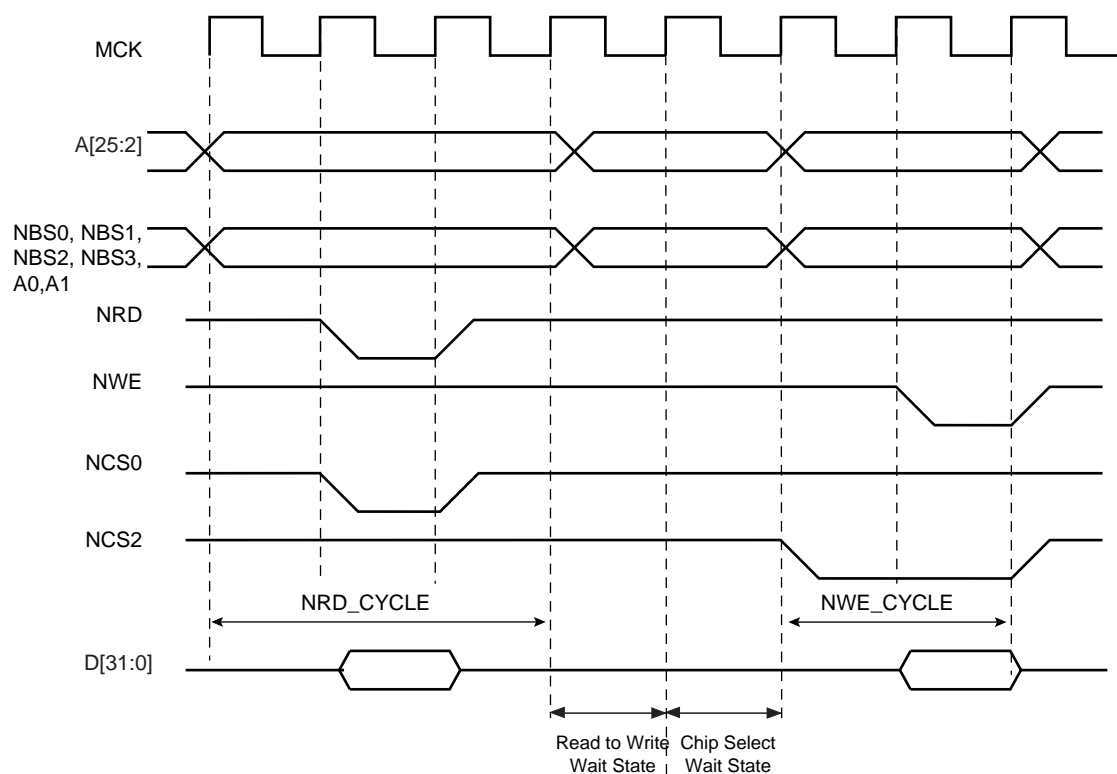

20.9.2 Early Read Wait State

In some cases, the SMC inserts a wait state cycle between a write access and a read access to allow time for the write cycle to end before the subsequent read cycle begins. This wait state is not generated in addition to a chip select wait state. The early read cycle thus only occurs between a write and read access to the same memory device (same chip select).

An early read wait state is automatically inserted if at least one of the following conditions is valid:

- if the write controlling signal has no hold time and the read controlling signal has no setup time (Figure 20-17).
- in NCS write controlled mode ($WRITE_MODE = 0$), if there is no hold timing on the NCS signal and the NCS_RD_SETUP parameter is set to 0, regardless of the read mode (Figure 20-18). The write operation must end with a NCS rising edge. Without an Early Read Wait State, the write operation could not complete properly.
- in NWE controlled mode ($WRITE_MODE = 1$) and if there is no hold timing ($NWE_HOLD = 0$), the feedback of the write control signal is used to control address, data, chip select and byte select lines. If the external write control signal is not inactivated as expected due to load capacitances, an Early Read Wait State is inserted and address, data and control signals are maintained one more cycle. See Figure 20-19.

Figure 20-17. Early Read Wait State: Write with No Hold Followed by Read with No Setup

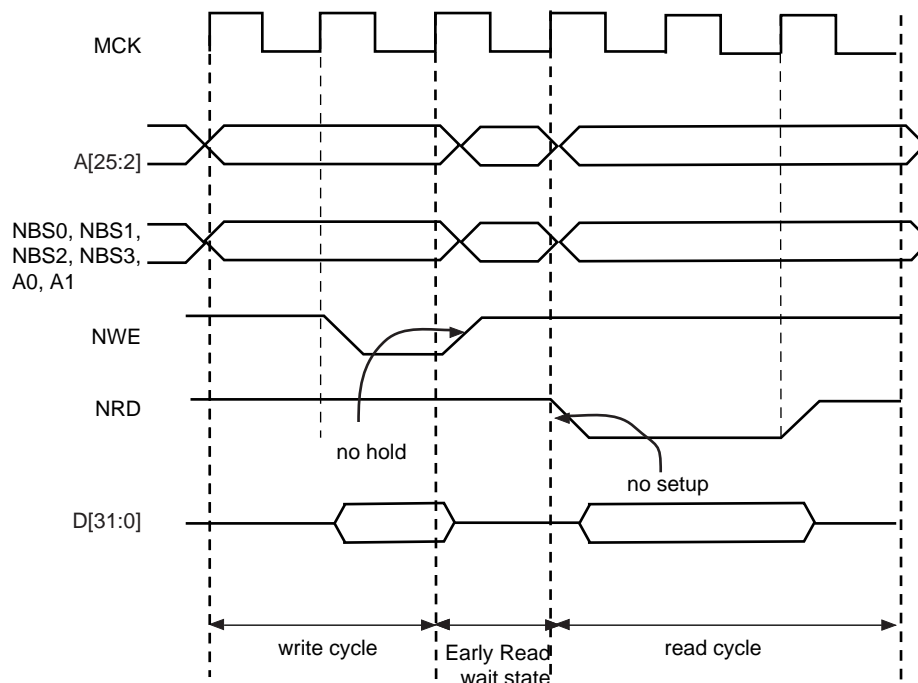

Figure 20-18. Early Read Wait State: NCS Controlled Write with No Hold Followed by a Read with No NCS Setup

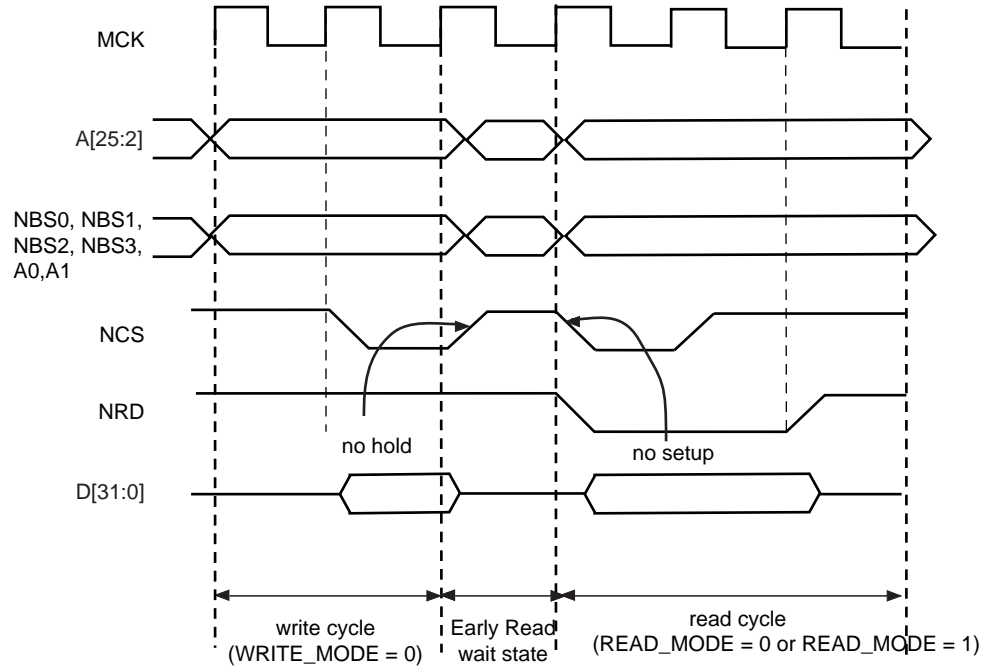
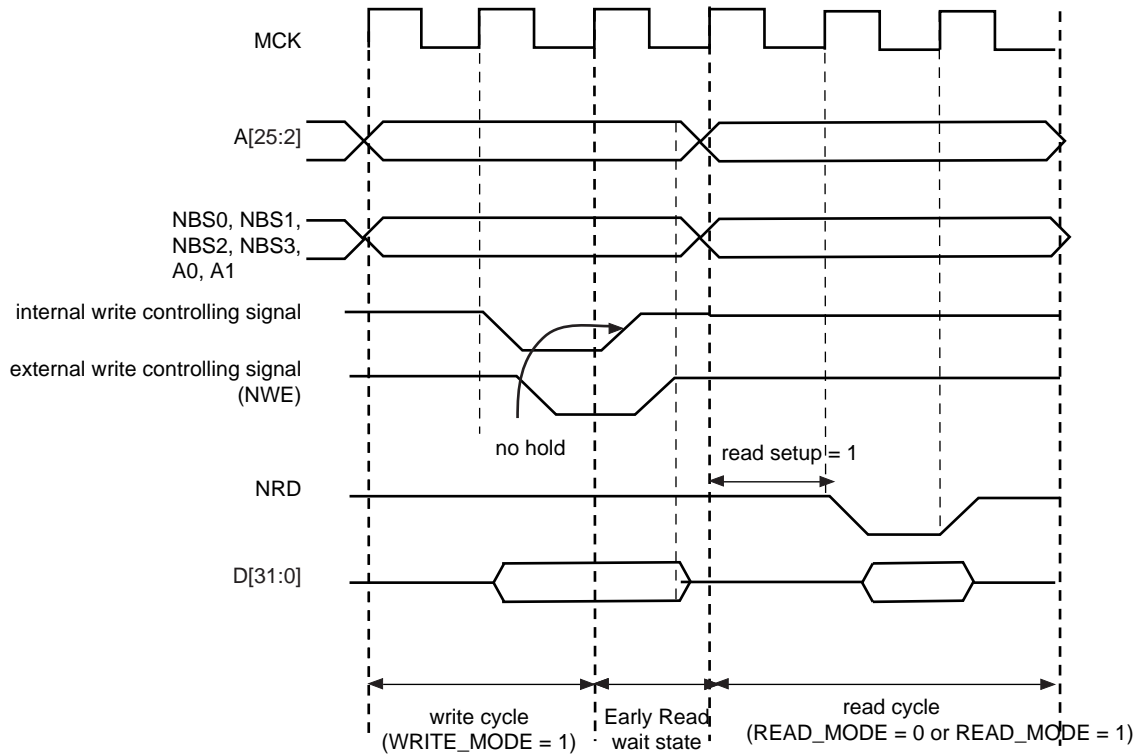

Figure 20-19. Early Read Wait State: NWE-controlled Write with No Hold Followed by a Read with one Setup Cycle



20.9.3 Reload User Configuration Wait State

The user may change any of the configuration parameters by writing the SMC user interface.

When detecting that a new user configuration has been written in the user interface, the SMC inserts a wait state before starting the next access. The so called “Reload User Configuration Wait State” is used by the SMC to load the new set of parameters to apply to next accesses.

The Reload Configuration Wait State is not applied in addition to the Chip Select Wait State. If accesses before and after re-programming the user interface are made to different devices (Chip Selects), then one single Chip Select Wait State is applied.

On the other hand, if accesses before and after writing the user interface are made to the same device, a Reload Configuration Wait State is inserted, even if the change does not concern the current Chip Select.

20.9.3.1 User Procedure

To insert a Reload Configuration Wait State, the SMC detects a write access to any SMC_MODE register of the user interface. If the user only modifies timing registers (SMC_SETUP, SMC_PULSE, SMC_CYCLE registers) in the user interface, he must validate the modification by writing the SMC_MODE, even if no change was made on the mode parameters.

The user must not change the configuration parameters of an SMC Chip Select (Setup, Pulse, Cycle, Mode) if accesses are performed on this CS during the modification. Any change of the Chip Select parameters, while fetching the code from a memory connected on this CS, may lead to unpredictable behavior. The instructions used to modify the parameters of an SMC Chip Select can be executed from the internal RAM or from a memory connected to another CS.

20.9.3.2 Slow Clock Mode Transition

A Reload Configuration Wait State is also inserted when the Slow Clock Mode is entered or exited, after the end of the current transfer (see “[Slow Clock Mode](#)” on page 182).

20.9.4 Read to Write Wait State

Due to an internal mechanism, a wait cycle is always inserted between consecutive read and write SMC accesses.

This wait cycle is referred to as a read to write wait state in this document.

This wait cycle is applied in addition to chip select and reload user configuration wait states when they are to be inserted. See [Figure 20-16 on page 168](#).

20.10 Data Float Wait States

Some memory devices are slow to release the external bus. For such devices, it is necessary to add wait states (data float wait states) after a read access:

- before starting a read access to a different external memory
- before starting a write access to the same device or to a different external one.

The Data Float Output Time (t_{DF}) for each external memory device is programmed in the TDF_CYCLES field of the SMC_MODE register for the corresponding chip select. The value of TDF_CYCLES indicates the number of data float wait cycles (between 0 and 15) before the external device releases the bus, and represents the time allowed for the data output to go to high impedance after the memory is disabled.

Data float wait states do not delay internal memory accesses. Hence, a single access to an external memory with long t_{DF} will not slow down the execution of a program from internal memory.

The data float wait states management depends on the READ_MODE and the TDF_MODE fields of the SMC_MODE register for the corresponding chip select.

20.10.1 READ_MODE

Setting the READ_MODE to 1 indicates to the SMC that the NRD signal is responsible for turning off the tri-state buffers of the external memory device. The Data Float Period then begins after the rising edge of the NRD signal and lasts TDF_CYCLES MCK cycles.

When the read operation is controlled by the NCS signal (READ_MODE = 0), the TDF field gives the number of MCK cycles during which the data bus remains busy after the rising edge of NCS.

Figure 20-20 illustrates the Data Float Period in NRD-controlled mode (READ_MODE = 1), assuming a data float period of 2 cycles (TDF_CYCLES = 2). Figure 20-21 shows the read operation when controlled by NCS (READ_MODE = 0) and the TDF_CYCLES parameter equals 3.

Figure 20-20. TDF Period in NRD Controlled Read Access (TDF = 2)

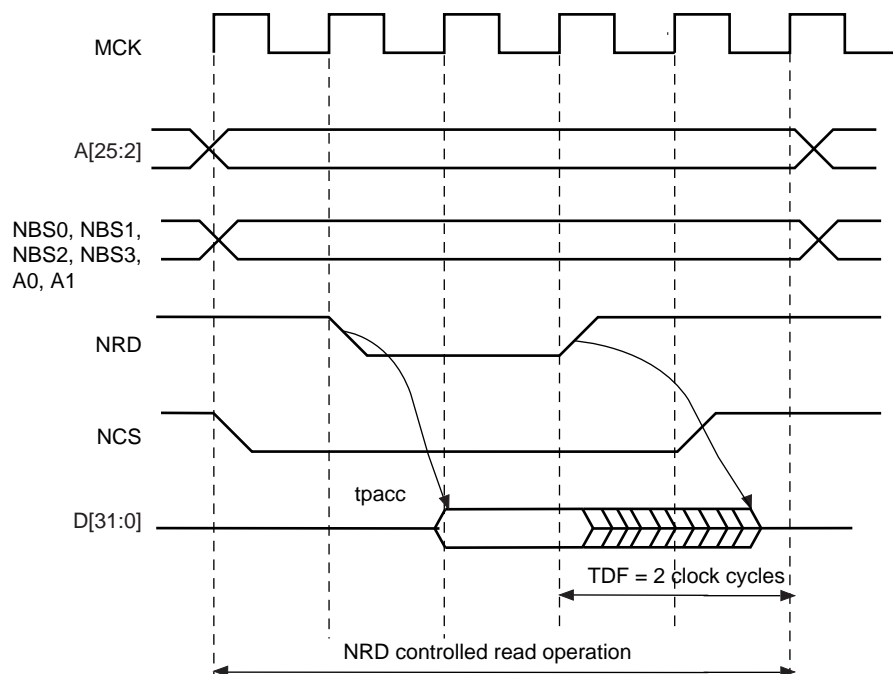
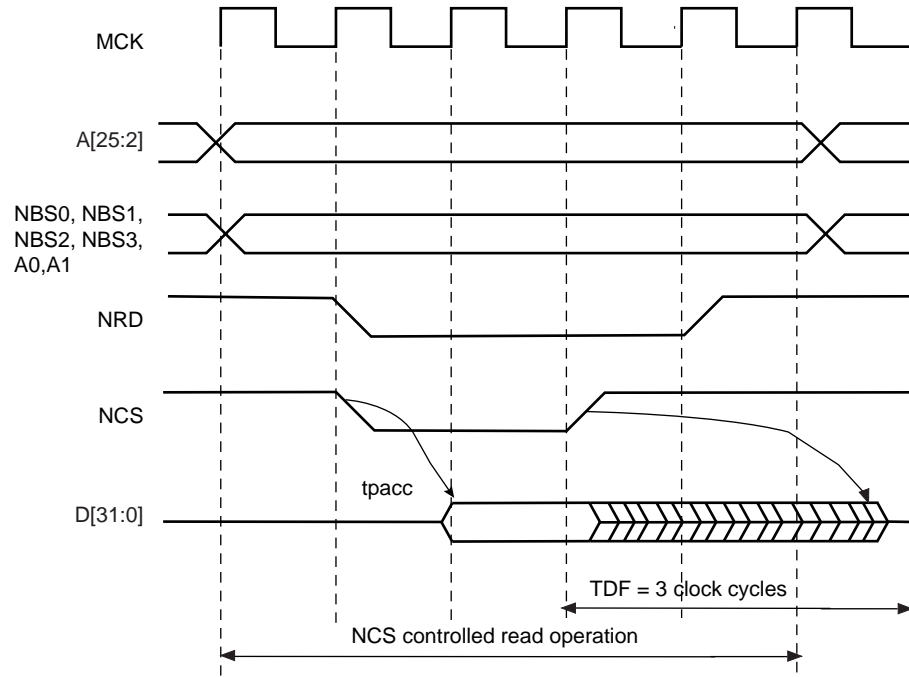

Figure 20-21. TDF Period in NCS Controlled Read Operation (TDF = 3)



20.10.2 TDF Optimization Enabled (TDF_MODE = 1)

When the TDF_MODE of the SMC_MODE register is set to 1 (TDF optimization is enabled), the SMC takes advantage of the setup period of the next access to optimize the number of wait states cycle to insert.

Figure 20-22 shows a read access controlled by NRD, followed by a write access controlled by NWE, on Chip Select 0. Chip Select 0 has been programmed with:

NRD_HOLD = 4; READ_MODE = 1 (NRD controlled)

NWE_SETUP = 3; WRITE_MODE = 1 (NWE controlled)

TDF_CYCLES = 6; TDF_MODE = 1 (optimization enabled).

Figure 20-22. TDF Optimization: No TDF wait states are inserted if the TDF period is over when the next access begins

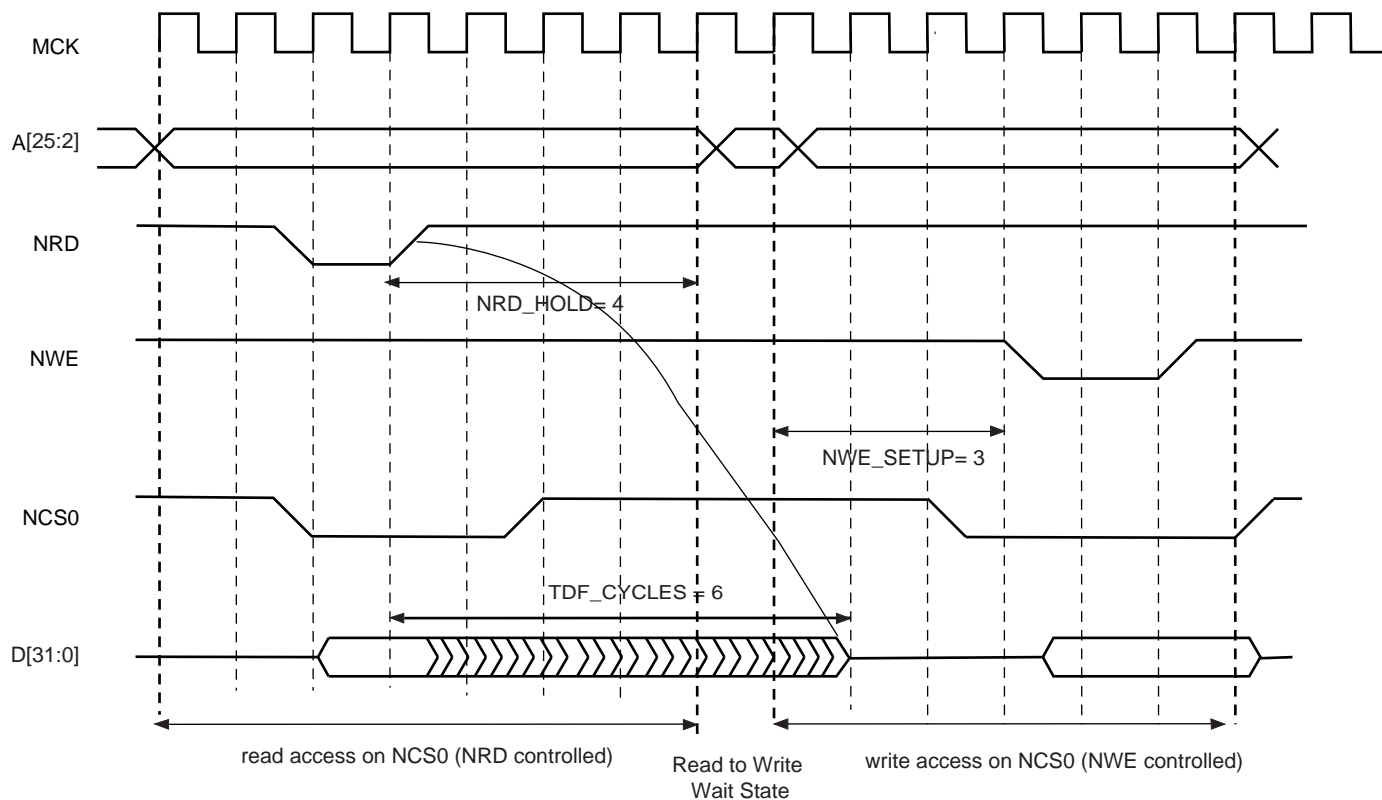

20.10.3 TDF Optimization Disabled (TDF_MODE = 0)

When optimization is disabled, tdf wait states are inserted at the end of the read transfer, so that the data float period is ended when the second access begins. If the hold period of the read1 controlling signal overlaps the data float period, no additional tdf wait states will be inserted.

Figure 20-23, Figure 20-24 and Figure 20-25 illustrate the cases:

- read access followed by a read access on another chip select,
- read access followed by a write access on another chip select,
- read access followed by a write access on the same chip select,

with no TDF optimization.

Figure 20-23. TDF Optimization Disabled (TDF Mode = 0). TDF wait states between 2 read accesses on different chip selects

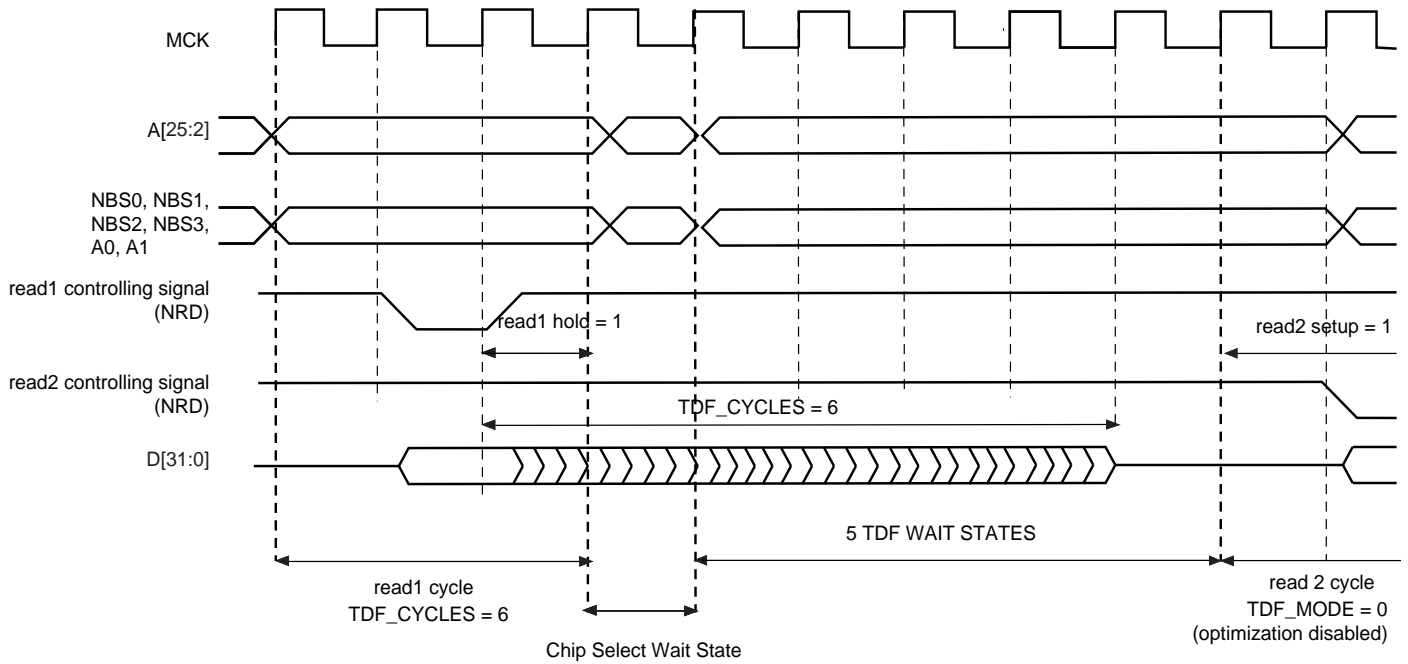

Figure 20-24. TDF Mode = 0: TDF wait states between a read and a write access on different chip selects

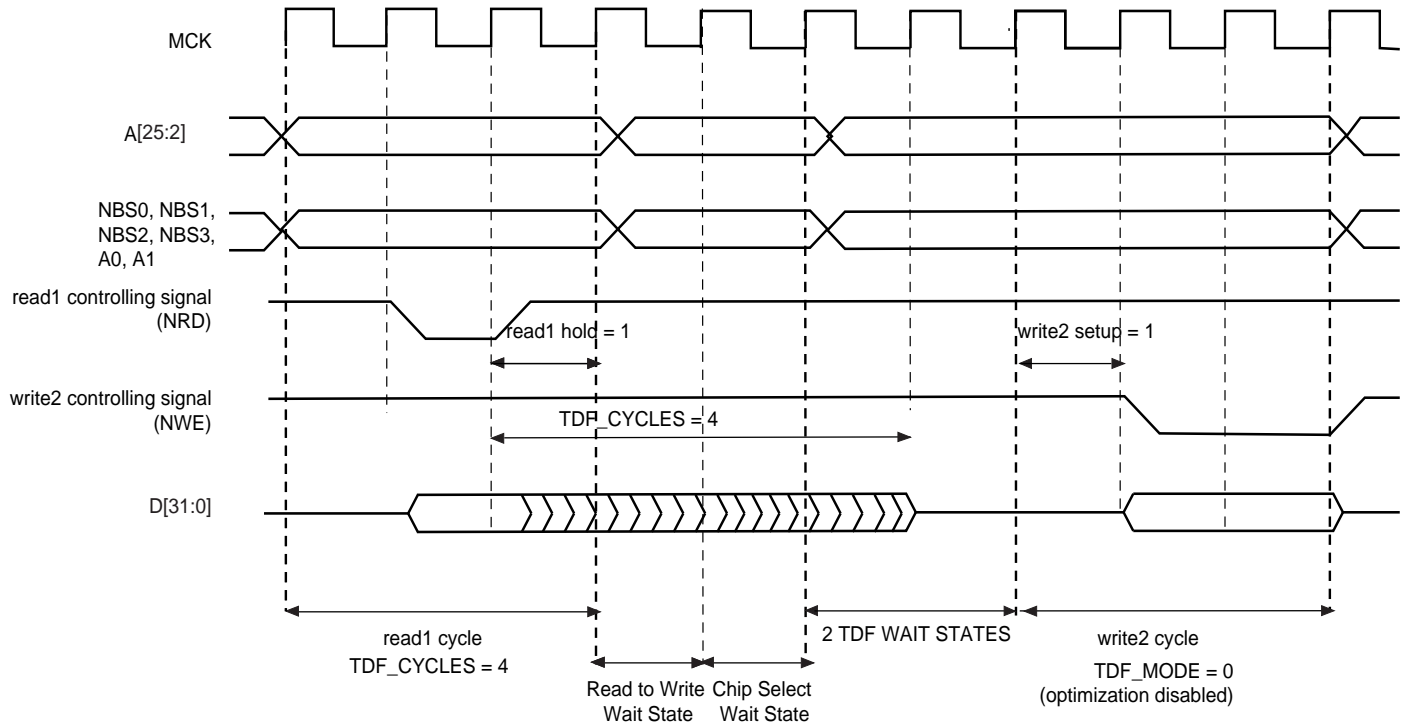
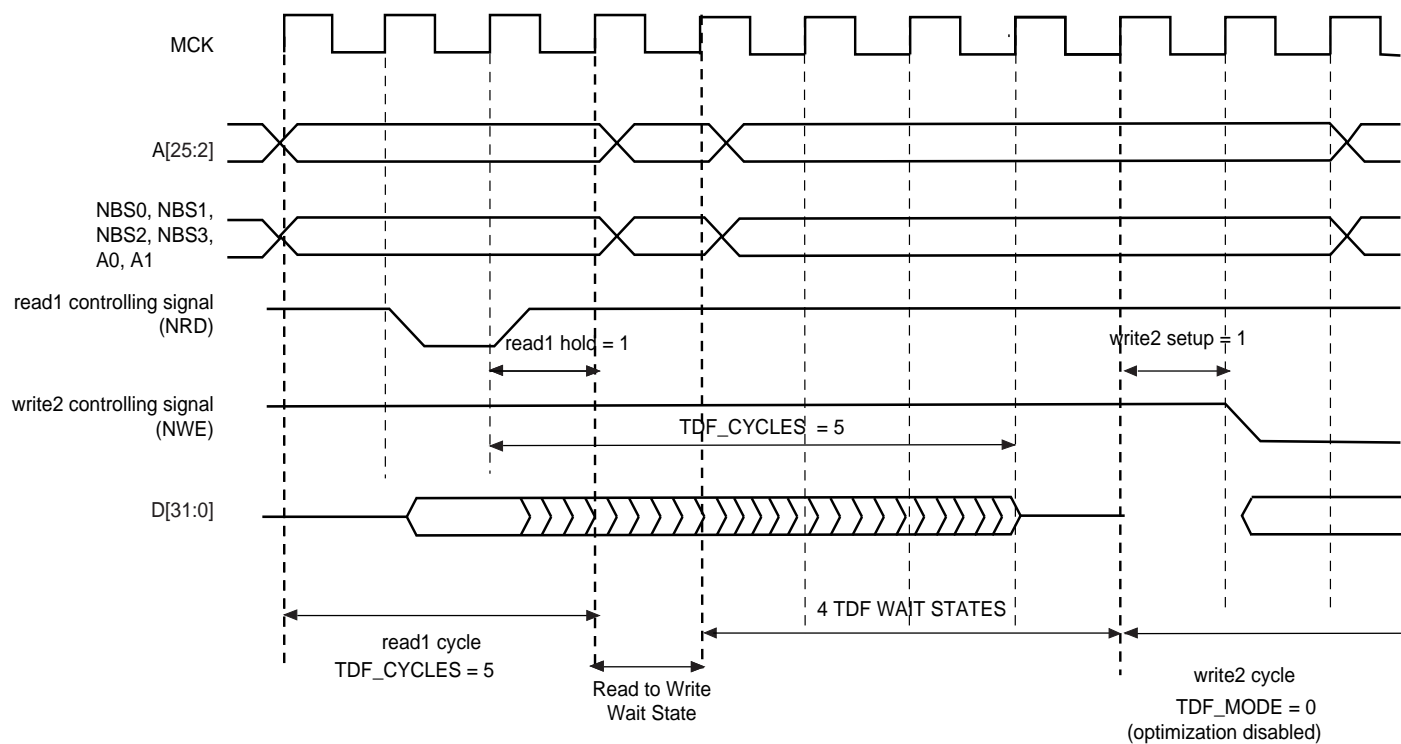

Figure 20-25. TDF Mode = 0: TDF wait states between read and write accesses on the same chip select



20.11 External Wait

Any access can be extended by an external device using the NWAIT input signal of the SMC. The EXNW_MODE field of the SMC_MODE register on the corresponding chip select must be set to either to “10” (frozen mode) or “11” (ready mode). When the EXNW_MODE is set to “00” (disabled), the NWAIT signal is simply ignored on the corresponding chip select. The NWAIT signal delays the read or write operation in regards to the read or write controlling signal, depending on the read and write modes of the corresponding chip select.

20.11.1 Restriction

When one of the EXNW_MODE is enabled, it is mandatory to program at least one hold cycle for the read/write controlling signal. For that reason, the NWAIT signal cannot be used in Page Mode ([“Asynchronous Page Mode” on page 184](#)), or in Slow Clock Mode ([“Slow Clock Mode” on page 182](#)).

The NWAIT signal is assumed to be a response of the external device to the read/write request of the SMC. Then NWAIT is examined by the SMC only in the pulse state of the read or write controlling signal. The assertion of the NWAIT signal outside the expected period has no impact on SMC behavior.

20.11.2 Frozen Mode

When the external device asserts the NWAIT signal (active low), and after internal synchronization of this signal, the SMC state is frozen, i.e., SMC internal counters are frozen, and all control signals remain unchanged. When the resynchronized NWAIT signal is deasserted, the SMC completes the access, resuming the access from the point where it was stopped. See [Figure 20-26](#). This mode must be selected when the external device uses the NWAIT signal to delay the access and to freeze the SMC.

The assertion of the NWAIT signal outside the expected period is ignored as illustrated in [Figure 20-27](#).

Figure 20-26. Write Access with NWAIT Assertion in Frozen Mode (EXNW_MODE = 10)

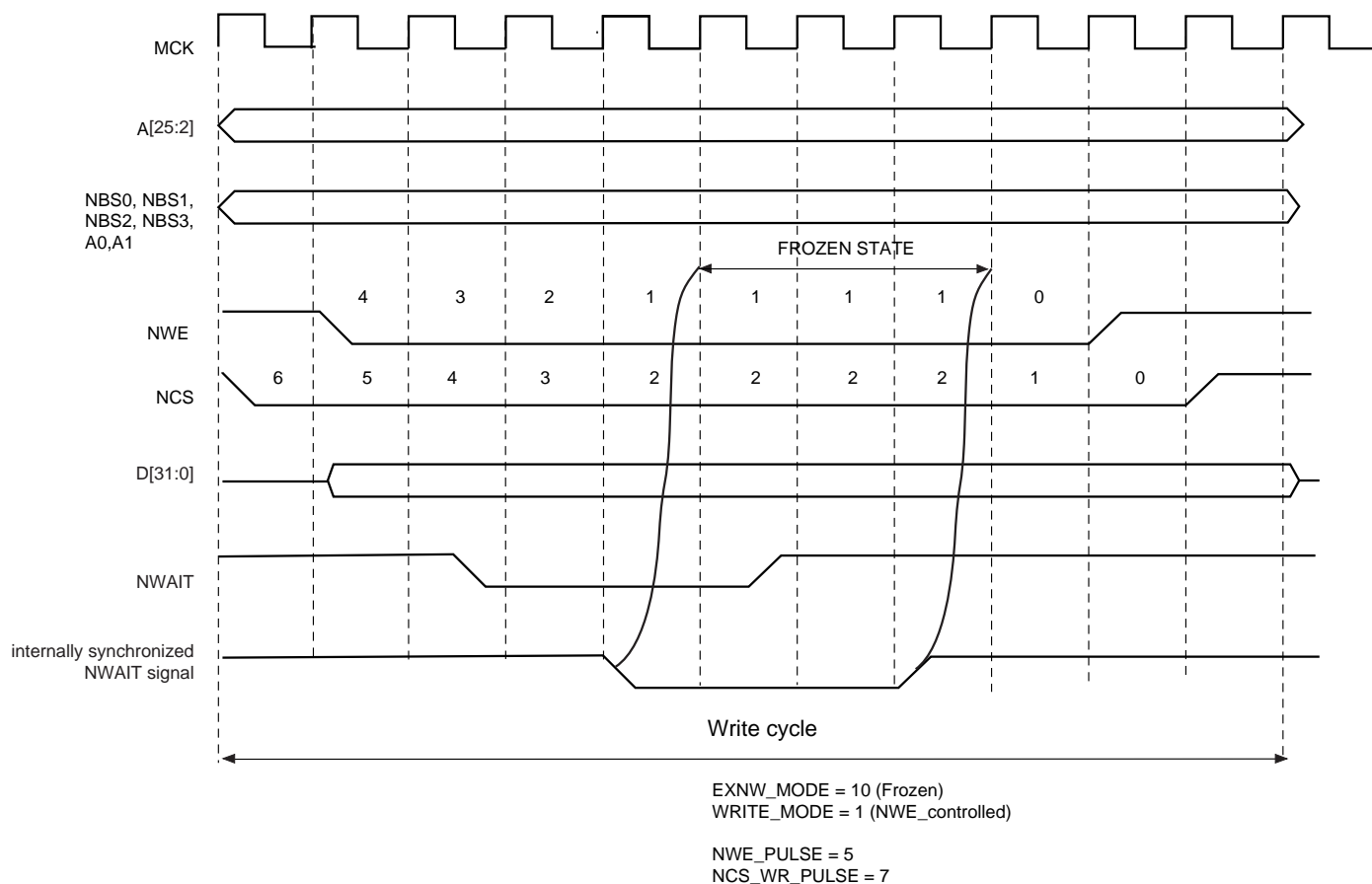
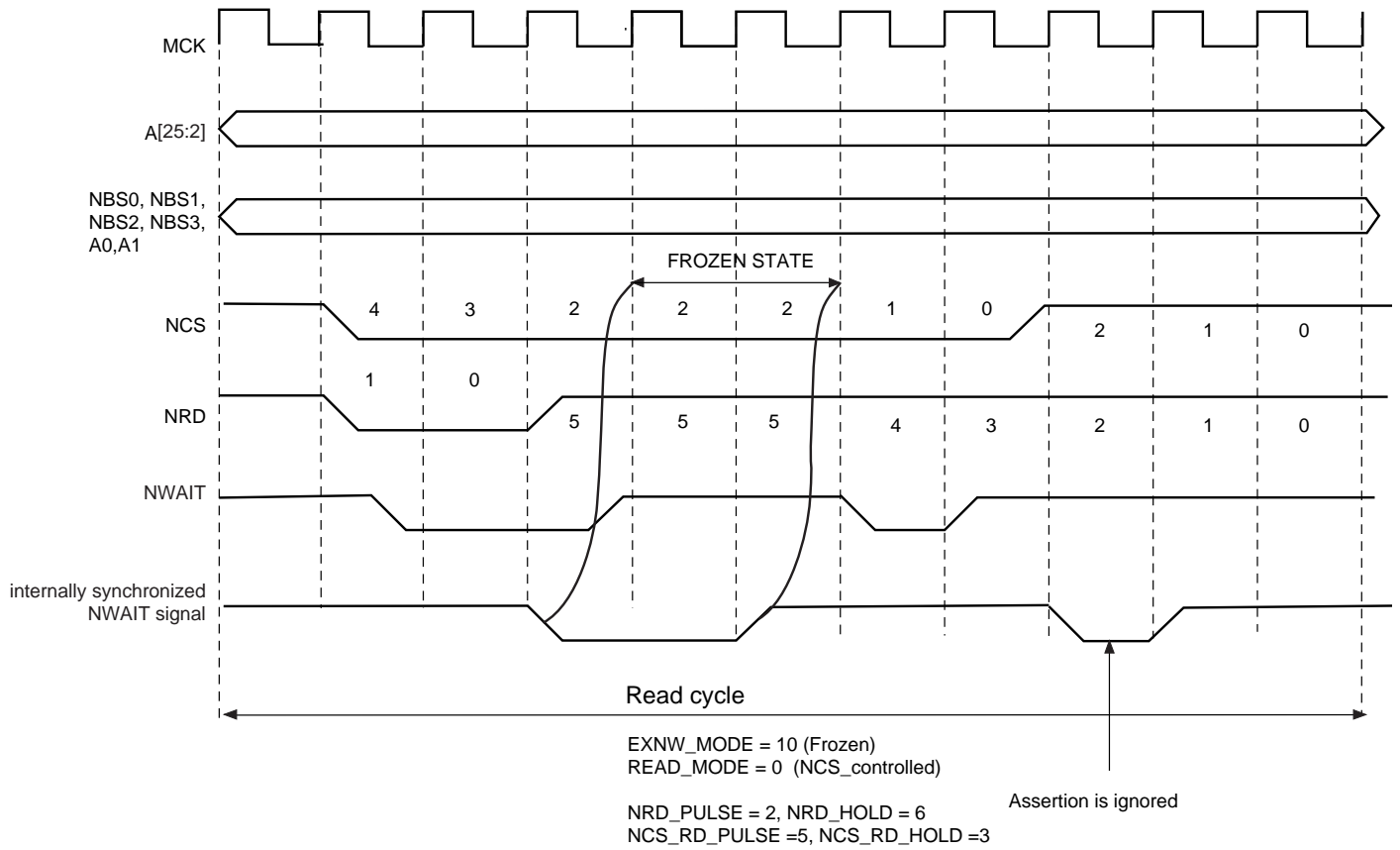

Figure 20-27. Read Access with NWAIT Assertion in Frozen Mode (EXNW_MODE = 10)



20.11.3 Ready Mode

In Ready mode (EXNW_MODE = 11), the SMC behaves differently. Normally, the SMC begins the access by down counting the setup and pulse counters of the read/write controlling signal. In the last cycle of the pulse phase, the resynchronized NWAIT signal is examined.

If asserted, the SMC suspends the access as shown in Figure 20-28 and Figure 20-29. After deassertion, the access is completed: the hold step of the access is performed.

This mode must be selected when the external device uses deassertion of the NWAIT signal to indicate its ability to complete the read or write operation.

If the NWAIT signal is deasserted before the end of the pulse, or asserted after the end of the pulse of the controlling read/write signal, it has no impact on the access length as shown in Figure 20-29.

Figure 20-28. NWAIT Assertion in Write Access: Ready Mode (EXNW_MODE = 11)

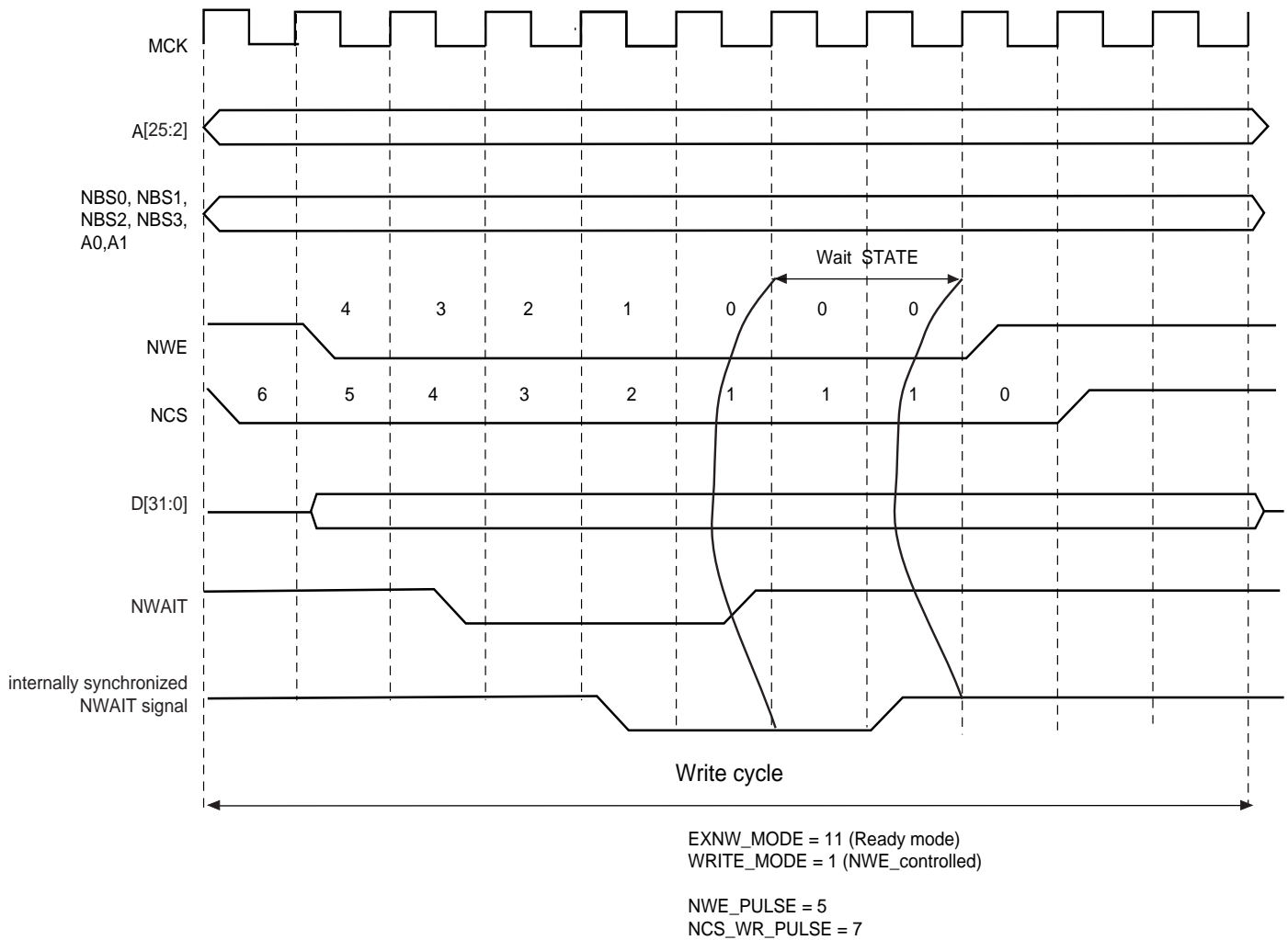
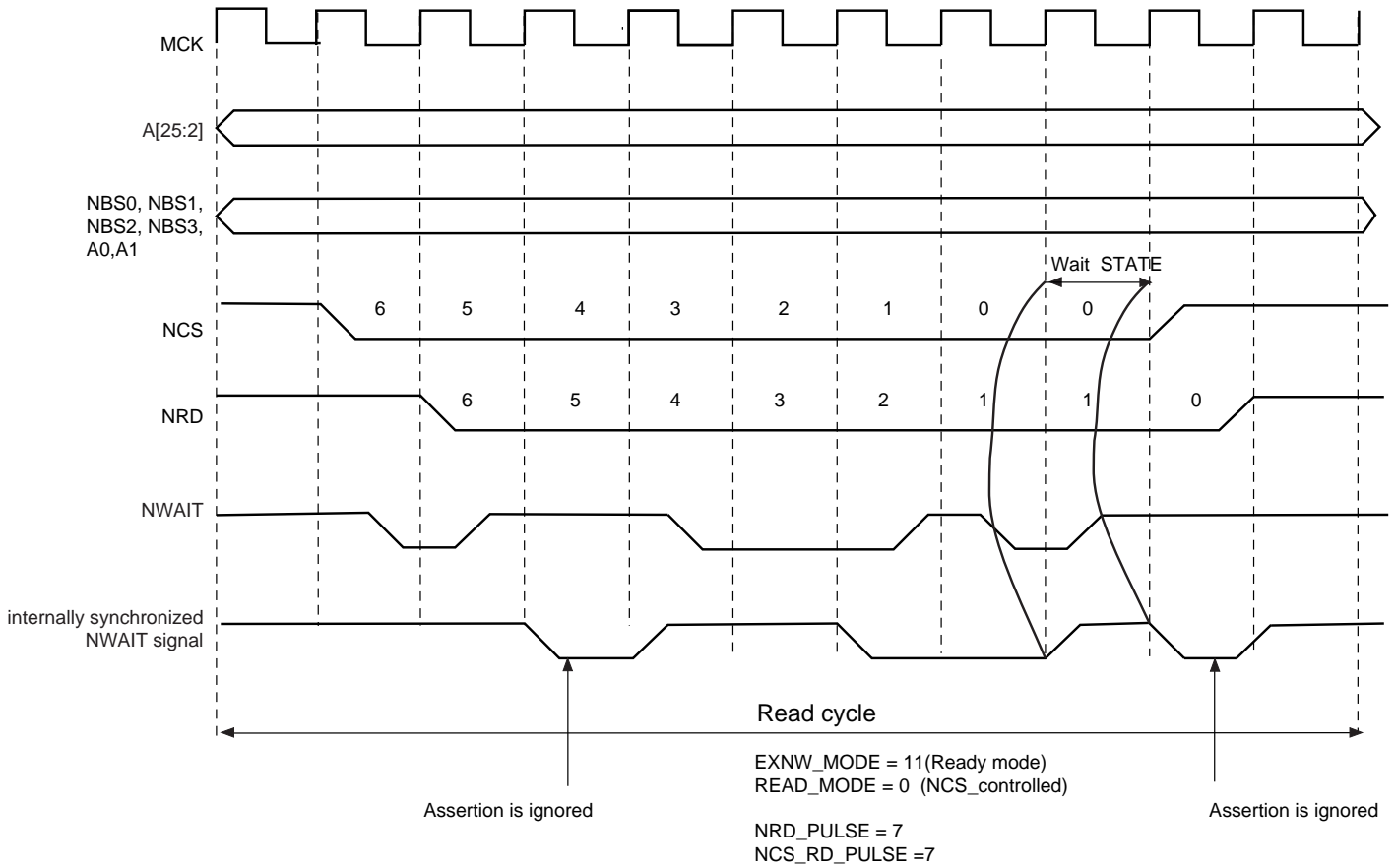

Figure 20-29. NWAIT Assertion in Read Access: Ready Mode (EXNW_MODE = 11)



20.11.4 NWAIT Latency and Read/Write Timings

There may be a latency between the assertion of the read/write controlling signal and the assertion of the NWAIT signal by the device. The programmed pulse length of the read/write controlling signal must be at least equal to this latency plus the 2 cycles of resynchronization + 1 cycle. Otherwise, the SMC may enter the hold state of the access without detecting the NWAIT signal assertion. This is true in frozen mode as well as in ready mode. This is illustrated on [Figure 20-30](#).

When EXNW_MODE is enabled (ready or frozen), the user must program a pulse length of the read and write controlling signal of at least:

minimal pulse length = NWAIT latency + 2 resynchronization cycles + 1 cycle

Figure 20-30. NWAIT Latency

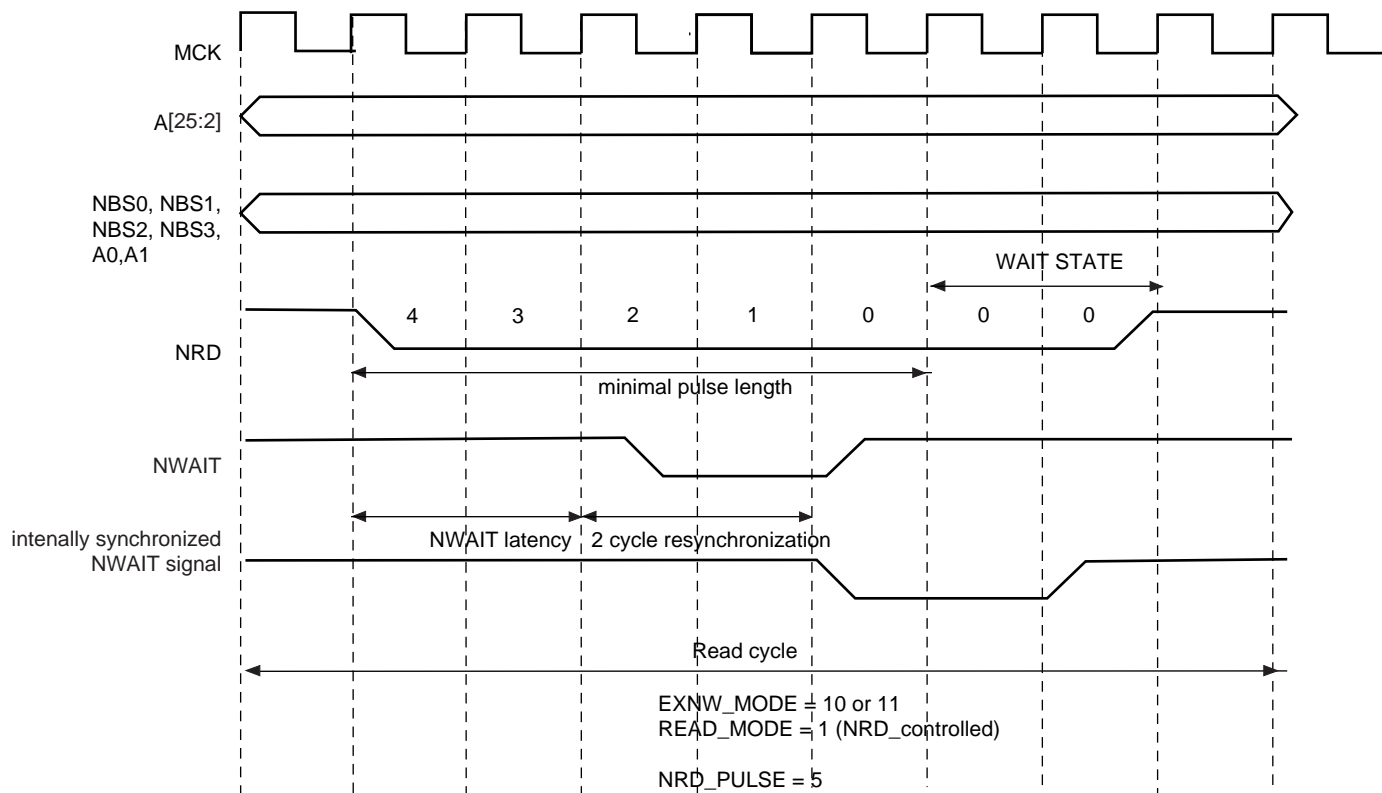

20.12 Slow Clock Mode

The SMC is able to automatically apply a set of “slow clock mode” read/write waveforms when an internal signal driven by the Power Management Controller is asserted because MCK has been turned to a very slow clock rate (typically 32kHz clock rate). In this mode, the user-programmed waveforms are ignored and the slow clock mode waveforms are applied. This mode is provided so as to avoid reprogramming the User Interface with appropriate waveforms at very slow clock rate. When activated, the slow mode is active on all chip selects.

20.12.1 Slow Clock Mode Waveforms

Figure 20-31 illustrates the read and write operations in slow clock mode. They are valid on all chip selects. Table 20-5 indicates the value of read and write parameters in slow clock mode.

Figure 20-31. Read/write Cycles in Slow Clock Mode

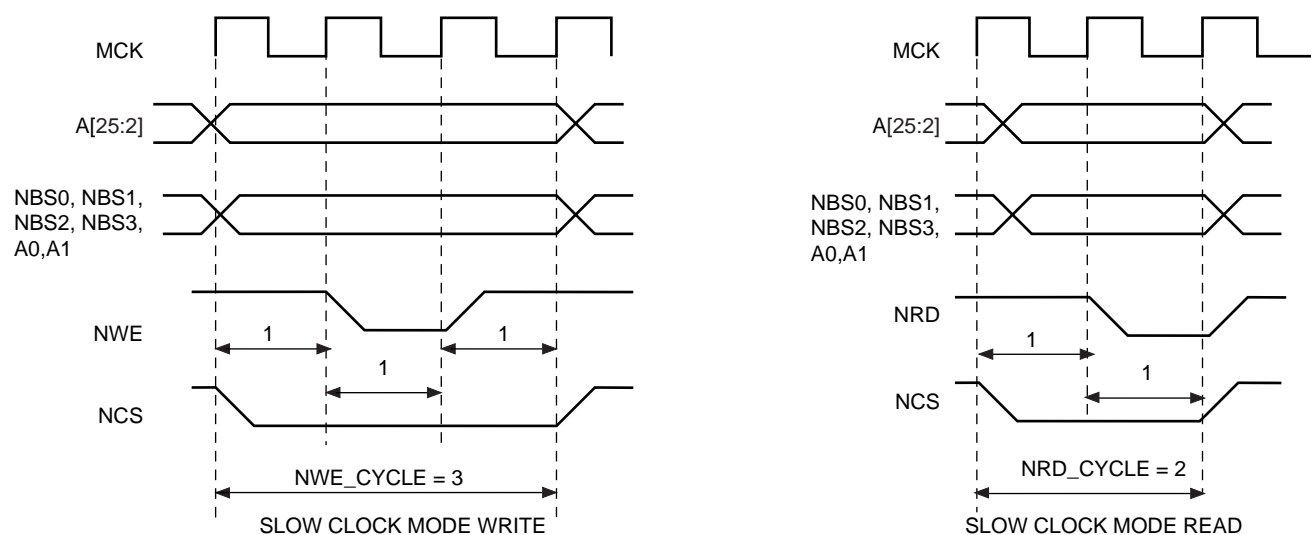

Table 20-5. Read and Write Timing Parameters in Slow Clock Mode

| Read Parameters | Duration (cycles) | Write Parameters | Duration (cycles) |
|-----------------|-------------------|------------------|-------------------|
| NRD_SETUP | 1 | NWE_SETUP | 1 |
| NRD_PULSE | 1 | NWE_PULSE | 1 |
| NCS_RD_SETUP | 0 | NCS_WR_SETUP | 0 |
| NCS_RD_PULSE | 2 | NCS_WR_PULSE | 3 |
| NRD_CYCLE | 2 | NWE_CYCLE | 3 |

20.12.2 Switching from (to) Slow Clock Mode to (from) Normal Mode

When switching from slow clock mode to the normal mode, the current slow clock mode transfer is completed at high clock rate, with the set of slow clock mode parameters. See Figure 20-32. The external device may not be fast enough to support such timings.

Figure 20-33 illustrates the recommended procedure to properly switch from one mode to the other.

Figure 20-32. Clock Rate Transition Occurs while the SMC is Performing a Write Operation

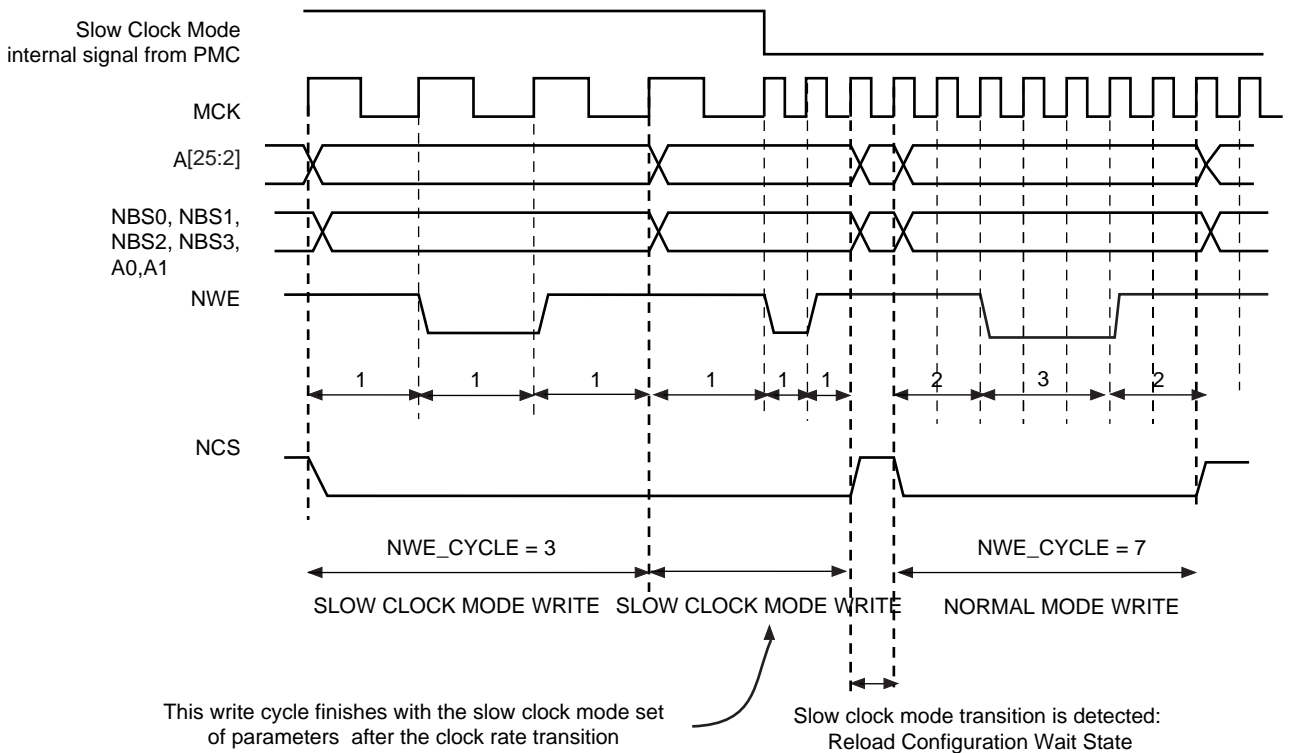
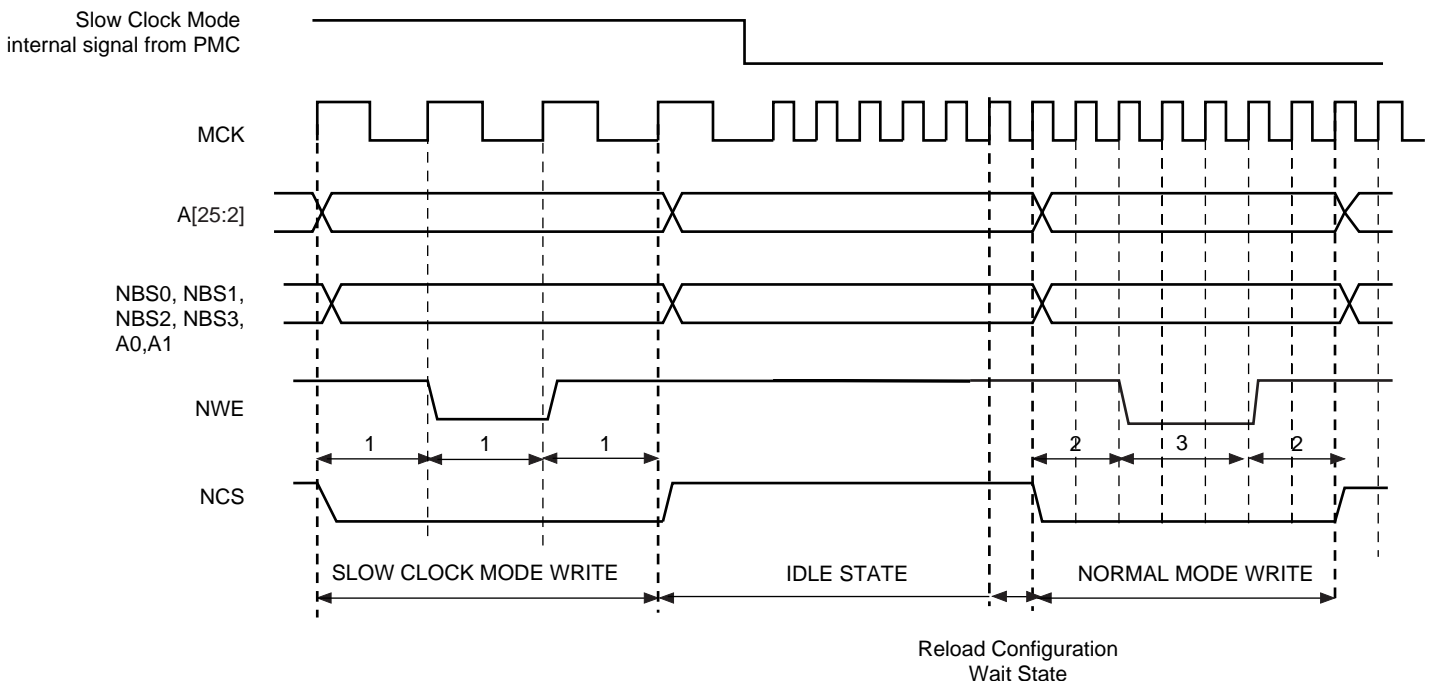

Figure 20-33. Recommended Procedure to Switch from Slow Clock Mode to Normal Mode or from Normal Mode to Slow Clock Mode



20.13 Asynchronous Page Mode

The SMC supports asynchronous burst reads in page mode, providing that the page mode is enabled in the SMC_MODE register (PMEN field). The page size must be configured in the SMC_MODE register (PS field) to 4, 8, 16 or 32 bytes.

The page defines a set of consecutive bytes into memory. A 4-byte page (resp. 8-, 16-, 32-byte page) is always aligned to 4-byte boundaries (resp. 8-, 16-, 32-byte boundaries) of memory. The MSB of data address defines the address of the page in memory, the LSB of address define the address of the data in the page as detailed in [Table 20-6](#).

With page mode memory devices, the first access to one page (t_{pa}) takes longer than the subsequent accesses to the page (t_{sa}) as shown in [Figure 20-34](#). When in page mode, the SMC enables the user to define different read timings for the first access within one page, and next accesses within the page.

Table 20-6. Page Address and Data Address within a Page

| Page Size | Page Address ⁽¹⁾ | Data Address in the Page ⁽²⁾ |
|-----------|-----------------------------|---|
| 4 bytes | A[25:2] | A[1:0] |
| 8 bytes | A[25:3] | A[2:0] |
| 16 bytes | A[25:4] | A[3:0] |
| 32 bytes | A[25:5] | A[4:0] |

- Notes: 1. A denotes the address bus of the memory device
 2. For 16-bit devices, the bit 0 of address is ignored. For 32-bit devices, bits [1:0] are ignored.

20.13.1 Protocol and Timings in Page Mode

[Figure 20-34](#) shows the NRD and NCS timings in page mode access.

Figure 20-34. Page Mode Read Protocol (Address MSB and LSB are defined in [Table 20-6](#))

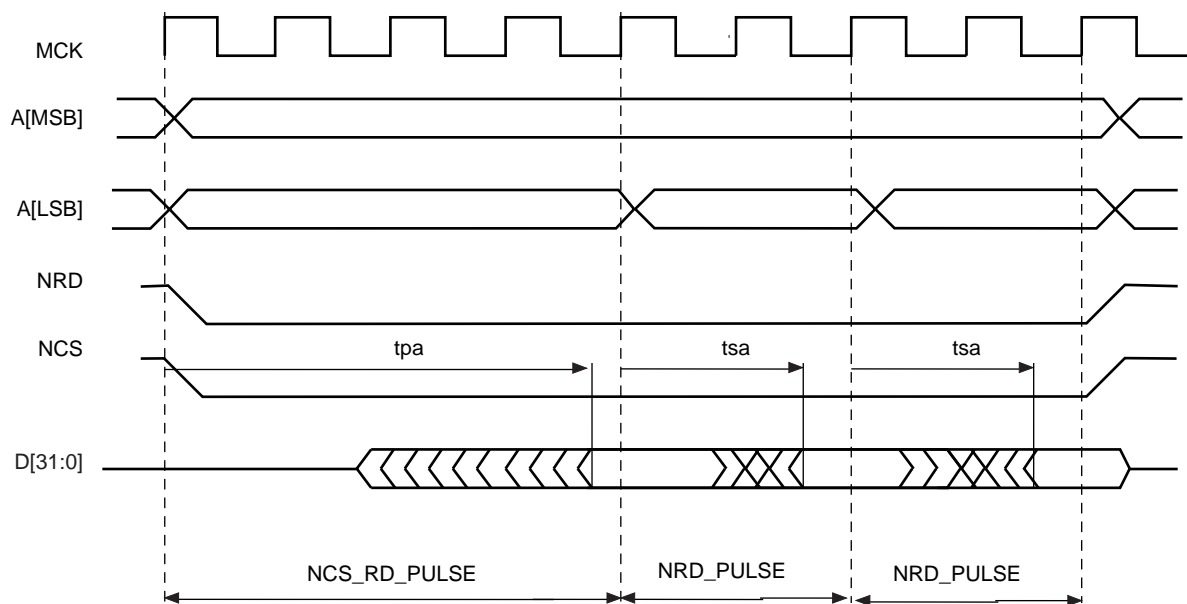

The NRD and NCS signals are held low during all read transfers, whatever the programmed values of the setup and hold timings in the User Interface may be. Moreover, the NRD and NCS timings are identical. The pulse length of the first access to the page is defined with the NCS_RD_PULSE field of the SMC_PULSE register. The pulse length of subsequent accesses within the page are defined using the NRD_PULSE parameter.

In page mode, the programming of the read timings is described in [Table 20-7](#).

Table 20-7. Programming of Read Timings in Page Mode

| Parameter | Value | Definition |
|--------------|----------|--|
| READ_MODE | 'x' | No impact |
| NCS_RD_SETUP | 'x' | No impact |
| NCS_RD_PULSE | t_{pa} | Access time of first access to the page |
| NRD_SETUP | 'x' | No impact |
| NRD_PULSE | t_{sa} | Access time of subsequent accesses in the page |
| NRD_CYCLE | 'x' | No impact |

The SMC does not check the coherency of timings. It will always apply the NCS_RD_PULSE timings as page access timing (t_{pa}) and the NRD_PULSE for accesses to the page (t_{sa}), even if the programmed value for t_{pa} is shorter than the programmed value for t_{sa} .

20.13.2 Byte Access Type in Page Mode

The Byte Access Type configuration remains active in page mode. For 16-bit or 32-bit page mode devices that require byte selection signals, configure the BAT field of the SMC Mode Register to 0 (byte select access type).

20.13.3 Page Mode Restriction

The page mode is not compatible with the use of the NWAIT signal. Using the page mode and the NWAIT signal may lead to unpredictable behavior.

20.13.4 Sequential and Non-sequential Accesses

If the chip select and the MSB of addresses as defined in [Table 20-6](#) are identical, then the current access lies in the same page as the previous one, and no page break occurs.

Using this information, all data within the same page, sequential or not sequential, are accessed with a minimum access time (t_{sa}). [Figure 20-35](#) illustrates access to an 8-bit memory device in page mode, with 8-byte pages. Access to D1 causes a page access with a long access time (t_{pa}). Accesses to D3 and D7, though they are not sequential accesses, only require a short access time (t_{sa}).

If the MSB of addresses are different, the SMC performs the access of a new page. In the same way, if the chip select is different from the previous access, a page break occurs. If two sequential accesses are made to the page mode memory, but separated by an other internal or external peripheral access, a page break occurs on the second access because the chip select of the device was deasserted between both accesses.

Figure 20-35. Access to Non-sequential Data within the Same Page

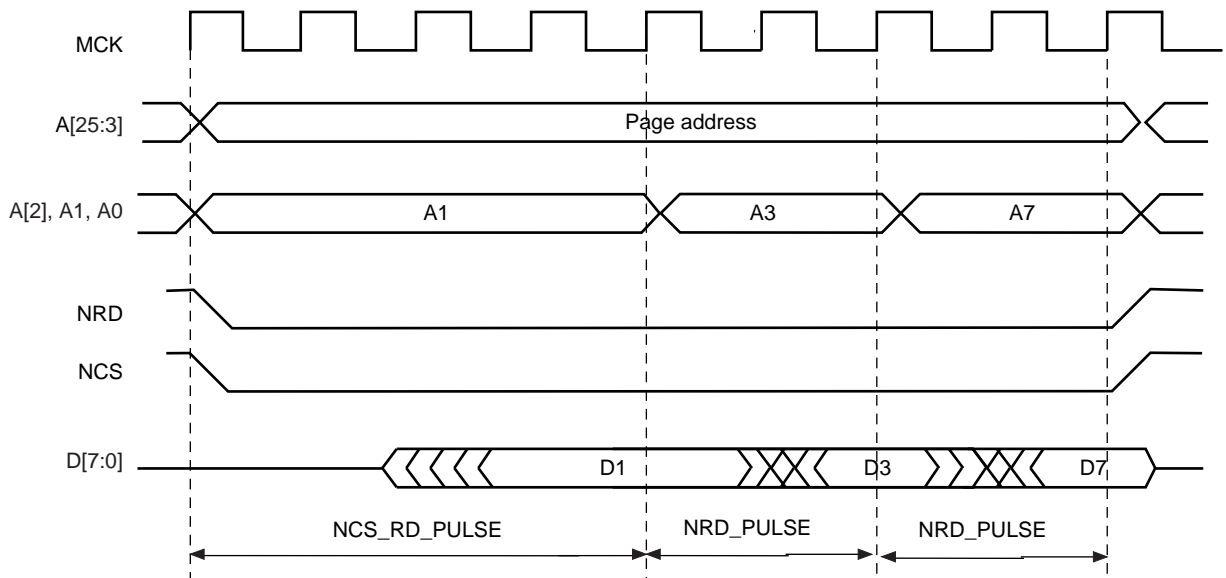

20.14 Static Memory Controller (SMC) User Interface

The SMC is programmed using the registers listed in [Table 20-8](#). For each chip select, a set of four registers is used to program the parameters of the external device connected on it. In [Table 20-8](#), “CS_number” denotes the chip select number. 16 bytes (0x10) are required per chip select.

The user must complete writing the configuration by writing any one of the SMC_MODE registers.

Table 20-8. Register Mapping

| Offset | Register | Name | Access | Reset |
|-------------------------|--------------------|-----------|------------|------------|
| 0x10 x CS_number + 0x00 | SMC Setup Register | SMC_SETUP | Read/Write | 0 |
| 0x10 x CS_number + 0x04 | SMC Pulse Register | SMC_PULSE | Read/Write | 0x01010101 |
| 0x10 x CS_number + 0x08 | SMC Cycle Register | SMC_CYCLE | Read/Write | 0x00010001 |
| 0x10 x CS_number + 0x0C | SMC Mode Register | SMC_MODE | Read/Write | 0x10001000 |
| 0xEC–0xFC | Reserved | – | – | – |

20.14.1 SMC Setup Register

Name: SMC_SETUP[0..7]

Address: 0xFFFFFEC0 [0], 0xFFFFFEC10 [1], 0xFFFFFEC20 [2], 0xFFFFFEC30 [3], 0xFFFFFEC40 [4], 0xFFFFFEC50 [5], 0xFFFFFEC60 [6], 0xFFFFFEC70 [7]

Access: Read/Write

| | | | | | | | |
|----|----|--------------|----|----|----|----|----|
| 31 | 30 | 29 | 28 | 27 | 26 | 25 | 24 |
| – | – | NCS_RD_SETUP | | | | | |
| 23 | 22 | 21 | 20 | 19 | 18 | 17 | 16 |
| – | – | NRD_SETUP | | | | | |
| 15 | 14 | 13 | 12 | 11 | 10 | 9 | 8 |
| – | – | NCS_WR_SETUP | | | | | |
| 7 | 6 | 5 | 4 | 3 | 2 | 1 | 0 |
| – | – | NWE_SETUP | | | | | |

- **NWE_SETUP: NWE Setup Length**

The NWE signal setup length is defined as:

$NWE\ setup\ length = (128 * NWE_SETUP[5] + NWE_SETUP[4:0])\ clock\ cycles$

- **NCS_WR_SETUP: NCS Setup Length in WRITE Access**

In write access, the NCS signal setup length is defined as:

$NCS\ setup\ length = (128 * NCS_WR_SETUP[5] + NCS_WR_SETUP[4:0])\ clock\ cycles$

- **NRD_SETUP: NRD Setup Length**

The NRD signal setup length is defined in clock cycles as:

$NRD\ setup\ length = (128 * NRD_SETUP[5] + NRD_SETUP[4:0])\ clock\ cycles$

- **NCS_RD_SETUP: NCS Setup Length in READ Access**

In read access, the NCS signal setup length is defined as:

$NCS\ setup\ length = (128 * NCS_RD_SETUP[5] + NCS_RD_SETUP[4:0])\ clock\ cycles$

20.14.2 SMC Pulse Register

Name: SMC_PULSE[0..7]

Address: 0xFFFFFEC04 [0], 0xFFFFFEC14 [1], 0xFFFFFEC24 [2], 0xFFFFFEC34 [3], 0xFFFFFEC44 [4], 0xFFFFFEC54 [5], 0xFFFFFEC64 [6], 0xFFFFFEC74 [7]

Access: Read/Write

| | | | | | | | |
|----|--------------|----|----|----|----|----|----|
| 31 | 30 | 29 | 28 | 27 | 26 | 25 | 24 |
| - | NCS_RD_PULSE | | | | | | |
| 23 | 22 | 21 | 20 | 19 | 18 | 17 | 16 |
| - | NRD_PULSE | | | | | | |
| 15 | 14 | 13 | 12 | 11 | 10 | 9 | 8 |
| - | NCS_WR_PULSE | | | | | | |
| 7 | 6 | 5 | 4 | 3 | 2 | 1 | 0 |
| - | NWE_PULSE | | | | | | |

- **NWE_PULSE: NWE Pulse Length**

The NWE signal pulse length is defined as:

$NWE \text{ pulse length} = (256 * NWE_PULSE[6] + NWE_PULSE[5:0]) \text{ clock cycles}$

The NWE pulse length must be at least 1 clock cycle.

- **NCS_WR_PULSE: NCS Pulse Length in WRITE Access**

In write access, the NCS signal pulse length is defined as:

$NCS \text{ pulse length} = (256 * NCS_WR_PULSE[6] + NCS_WR_PULSE[5:0]) \text{ clock cycles}$

The NCS pulse length must be at least 1 clock cycle.

- **NRD_PULSE: NRD Pulse Length**

In standard read access, the NRD signal pulse length is defined in clock cycles as:

$NRD \text{ pulse length} = (256 * NRD_PULSE[6] + NRD_PULSE[5:0]) \text{ clock cycles}$

The NRD pulse length must be at least 1 clock cycle.

In page mode read access, the NRD_PULSE parameter defines the duration of the subsequent accesses in the page.

- **NCS_RD_PULSE: NCS Pulse Length in READ Access**

In standard read access, the NCS signal pulse length is defined as:

$NCS \text{ pulse length} = (256 * NCS_RD_PULSE[6] + NCS_RD_PULSE[5:0]) \text{ clock cycles}$

The NCS pulse length must be at least 1 clock cycle.

In page mode read access, the NCS_RD_PULSE parameter defines the duration of the first access to one page.

20.14.3 SMC Cycle Register

Name: SMC_CYCLE[0..7]

Address: 0xFFFFFEC08 [0], 0xFFFFFEC18 [1], 0xFFFFFEC28 [2], 0xFFFFFEC38 [3], 0xFFFFFEC48 [4], 0xFFFFFEC58 [5], 0xFFFFFEC68 [6], 0xFFFFFEC78 [7]

Access: Read/Write

| | | | | | | | |
|-----------|----|----|----|----|----|----|-----------|
| 31 | 30 | 29 | 28 | 27 | 26 | 25 | 24 |
| – | – | – | – | – | – | – | NRD_CYCLE |
| 23 | 22 | 21 | 20 | 19 | 18 | 17 | 16 |
| NRD_CYCLE | | | | | | | |
| 15 | 14 | 13 | 12 | 11 | 10 | 9 | 8 |
| – | – | – | – | – | – | – | NWE_CYCLE |
| 7 | 6 | 5 | 4 | 3 | 2 | 1 | 0 |
| NWE_CYCLE | | | | | | | |

- **NWE_CYCLE: Total Write Cycle Length**

The total write cycle length is the total duration in clock cycles of the write cycle. It is equal to the sum of the setup, pulse and hold steps of the NWE and NCS signals. It is defined as:

Write cycle length = (NWE_CYCLE[8:7]*256 + NWE_CYCLE[6:0]) clock cycles

- **NRD_CYCLE: Total Read Cycle Length**

The total read cycle length is the total duration in clock cycles of the read cycle. It is equal to the sum of the setup, pulse and hold steps of the NRD and NCS signals. It is defined as:

Read cycle length = (NRD_CYCLE[8:7]*256 + NRD_CYCLE[6:0]) clock cycles

20.14.4 SMC Mode Register

Name: SMC_MODE[0..7]

Address: 0xFFFFFEC0C [0], 0xFFFFFEC1C [1], 0xFFFFFEC2C [2], 0xFFFFFEC3C [3], 0xFFFFFEC4C [4], 0xFFFFFEC5C [5], 0xFFFFFEC6C [6], 0xFFFFFEC7C [7]

Access: Read/Write

| | | | | | | | |
|----|----|-----------|----------|------------|----|------------|-----------|
| 31 | 30 | 29 | 28 | 27 | 26 | 25 | 24 |
| – | – | PS | | – | – | – | PMEN |
| 23 | 22 | 21 | 20 | 19 | 18 | 17 | 16 |
| – | – | – | TDF_MODE | TDF_CYCLES | | | |
| 15 | 14 | 13 | 12 | 11 | 10 | 9 | 8 |
| – | – | DBW | | – | – | – | BAT |
| 7 | 6 | 5 | 4 | 3 | 2 | 1 | 0 |
| – | – | EXNW_MODE | | – | – | WRITE_MODE | READ_MODE |

• READ_MODE:

1: The read operation is controlled by the NRD signal.

- If TDF cycles are programmed, the external bus is marked busy after the rising edge of NRD.
- If TDF optimization is enabled (TDF_MODE =1), TDF wait states are inserted after the setup of NRD.

0: The read operation is controlled by the NCS signal.

- If TDF cycles are programmed, the external bus is marked busy after the rising edge of NCS.
- If TDF optimization is enabled (TDF_MODE =1), TDF wait states are inserted after the setup of NCS.

• WRITE_MODE

1: The write operation is controlled by the NWE signal.

- If TDF optimization is enabled (TDF_MODE =1), TDF wait states will be inserted after the setup of NWE.

0: The write operation is controlled by the NCS signal.

- If TDF optimization is enabled (TDF_MODE =1), TDF wait states will be inserted after the setup of NCS.

• EXNW_MODE: NWAIT Mode

The NWAIT signal is used to extend the current read or write signal. It is only taken into account during the pulse phase of the read and write controlling signal. When the use of NWAIT is enabled, at least one cycle hold duration must be programmed for the read and write controlling signal.

| Value | NWAIT Mode |
|-------|-------------|
| 0 0 | Disabled |
| 0 1 | Reserved |
| 1 0 | Frozen Mode |
| 1 1 | Ready Mode |

- Disabled Mode: The NWAIT input signal is ignored on the corresponding Chip Select.
- Frozen Mode: If asserted, the NWAIT signal freezes the current read or write cycle. After deassertion, the read/write cycle is resumed from the point where it was stopped.

- **Ready Mode:** The NWAIT signal indicates the availability of the external device at the end of the pulse of the controlling read or write signal, to complete the access. If high, the access normally completes. If low, the access is extended until NWAIT returns high.

- **BAT: Byte Access Type**

This field is used only if DBW defines a 16- or 32-bit data bus.

- 1: Byte write access type:
 - Write operation is controlled using NCS, NWR0, NWR1, NWR2, NWR3.
 - Read operation is controlled using NCS and NRD.
- 0: Byte select access type:
 - Write operation is controlled using NCS, NWE, NBS0, NBS1, NBS2 and NBS3
 - Read operation is controlled using NCS, NRD, NBS0, NBS1, NBS2 and NBS3

- **DBW: Data Bus Width**

| Value | | Data Bus Width |
|-------|---|----------------|
| 0 | 0 | 8-bit bus |
| 0 | 1 | 16-bit bus |
| 1 | 0 | 32-bit bus |
| 1 | 1 | Reserved |

- **TDF_CYCLES: Data Float Time**

This field gives the integer number of clock cycles required by the external device to release the data after the rising edge of the read controlling signal. The SMC always provide one full cycle of bus turnaround after the TDF_CYCLES period. The external bus cannot be used by another chip select during TDF_CYCLES + 1 cycles. From 0 up to 15 TDF_CYCLES can be set.

- **TDF_MODE: TDF Optimization**

1: TDF optimization is enabled.

- The number of TDF wait states is optimized using the setup period of the next read/write access.

0: TDF optimization is disabled.

- The number of TDF wait states is inserted before the next access begins.

- **PMEN: Page Mode Enabled**

1: Asynchronous burst read in page mode is applied on the corresponding chip select.

0: Standard read is applied.

- **PS: Page Size**

If page mode is enabled, this field indicates the size of the page in bytes.

| Value | | Page Size |
|-------|---|--------------|
| 0 | 0 | 4-byte page |
| 0 | 1 | 8-byte page |
| 1 | 0 | 16-byte page |
| 1 | 1 | 32-byte page |

21. SDRAM Controller (SDRAMC)

21.1 Overview

The SDRAM Controller (SDRAMC) extends the memory capabilities of a chip by providing the interface to an external 16-bit or 32-bit SDRAM device. The page size supports ranges from 2048 to 8192 and the number of columns from 256 to 2048. It supports byte (8-bit), half-word (16-bit) and word (32-bit) accesses.

The SDRAM Controller supports a read or write burst length of one location. It keeps track of the active row in each bank, thus maximizing SDRAM performance, e.g., the application may be placed in one bank and data in the other banks. So as to optimize performance, it is advisable to avoid accessing different rows in the same bank.

The SDRAM controller supports a CAS latency of 1, 2 or 3 and optimizes the read access depending on the frequency.

The different modes available - self-refresh, powerdown and deep powerdown modes - minimize power consumption on the SDRAM device.

21.2 I/O Lines Description

Table 21-1. I/O Line Description

| Name | Description | Type | Active Level |
|----------------|------------------------------|--------|--------------|
| SDCK | SDRAM Clock | Output | |
| SDCKE | SDRAM Clock Enable | Output | High |
| SDCS | SDRAM Controller Chip Select | Output | Low |
| BA[1:0] | Bank Select Signals | Output | |
| RAS | Row Signal | Output | Low |
| CAS | Column Signal | Output | Low |
| SDWE | SDRAM Write Enable | Output | Low |
| NBS[3:0] | Data Mask Enable Signals | Output | Low |
| SDRAMC_A[12:0] | Address Bus | Output | |
| D[31:0] | Data Bus | I/O | |

21.3 Application Example

21.3.1 Software Interface

The SDRAM address space is organized into banks, rows, and columns. The SDRAM controller allows mapping different memory types according to the values set in the SDRAMC configuration register.

The SDRAM Controller's function is to make the SDRAM device access protocol transparent to the user. [Table 21-2](#) to [Table 21-7](#) illustrate the SDRAM device memory mapping seen by the user in correlation with the device structure. Various configurations are illustrated.

21.3.1.1 32-bit Memory Data Bus Width

Table 21-2. SDRAM Configuration Mapping: 2K Rows, 256/512/1024/2048 Columns

| CPU Address Line | | | | | | | | | | | | | | | | | | | | | | | | | | | |
|------------------|----|---------|---------|---------|---------|-----------|-----------|-----------|-----------|----|----|----|----|----|----|--------------|-------------|-------------|-------------|---|---|---|--------|--------|--------|--------|---|
| 27 | 26 | 25 | 24 | 23 | 22 | 21 | 20 | 19 | 18 | 17 | 16 | 15 | 14 | 13 | 12 | 11 | 10 | 9 | 8 | 7 | 6 | 5 | 4 | 3 | 2 | 1 | 0 |
| | | | | | Bk[1:0] | | | | Row[10:0] | | | | | | | | | | Column[7:0] | | | | | | | M[1:0] | |
| | | | | Bk[1:0] | | | | Row[10:0] | | | | | | | | | | Column[8:0] | | | | | | | M[1:0] | | |
| | | | Bk[1:0] | | | | Row[10:0] | | | | | | | | | | Column[9:0] | | | | | | | M[1:0] | | | |
| | | Bk[1:0] | | | | Row[10:0] | | | | | | | | | | Column[10:0] | | | | | | | M[1:0] | | | | |

Table 21-3. SDRAM Configuration Mapping: 4K Rows, 256/512/1024/2048 Columns

| CPU Address Line | | | | | | | | | | | | | | | | | | | | | | | | | | | |
|------------------|---------|---------|---------|---------|-----------|-----------|-----------|-----------|----|----|----|----|----|----|--------------|-------------|-------------|-------------|---|---|---|--------|--------|--------|--------|---|---|
| 27 | 26 | 25 | 24 | 23 | 22 | 21 | 20 | 19 | 18 | 17 | 16 | 15 | 14 | 13 | 12 | 11 | 10 | 9 | 8 | 7 | 6 | 5 | 4 | 3 | 2 | 1 | 0 |
| | | | | Bk[1:0] | | | | Row[11:0] | | | | | | | | | | Column[7:0] | | | | | | | M[1:0] | | |
| | | | Bk[1:0] | | | | Row[11:0] | | | | | | | | | | Column[8:0] | | | | | | | M[1:0] | | | |
| | | Bk[1:0] | | | | Row[11:0] | | | | | | | | | | Column[9:0] | | | | | | | M[1:0] | | | | |
| | Bk[1:0] | | | | Row[11:0] | | | | | | | | | | Column[10:0] | | | | | | | M[1:0] | | | | | |

Table 21-4. SDRAM Configuration Mapping: 8K Rows, 256/512/1024/2048 Columns

| CPU Address Line | | | | | | | | | | | | | | | | | | | | | | | | | | | |
|------------------|---------|---------|---------|-----------|-----------|-----------|-----------|----|----|----|----|----|----|--------------|-------------|-------------|-------------|---|---|---|--------|--------|--------|--------|---|---|---|
| 27 | 26 | 25 | 24 | 23 | 22 | 21 | 20 | 19 | 18 | 17 | 16 | 15 | 14 | 13 | 12 | 11 | 10 | 9 | 8 | 7 | 6 | 5 | 4 | 3 | 2 | 1 | 0 |
| | | | Bk[1:0] | | | | Row[12:0] | | | | | | | | | | Column[7:0] | | | | | | | M[1:0] | | | |
| | | Bk[1:0] | | | | Row[12:0] | | | | | | | | | | Column[8:0] | | | | | | | M[1:0] | | | | |
| | Bk[1:0] | | | | Row[12:0] | | | | | | | | | | Column[9:0] | | | | | | | M[1:0] | | | | | |
| Bk[1:0] | | | | Row[12:0] | | | | | | | | | | Column[10:0] | | | | | | | M[1:0] | | | | | | |

- Notes:
1. M[1:0] is the byte address inside a 32-bit word.
 3. Bk[1] = BA1, Bk[0] = BA0.

21.3.1.2 16-bit Memory Data Bus Width

Table 21-5. SDRAM Configuration Mapping: 2K Rows, 256/512/1024/2048 Columns

| CPU Address Line | | | | | | | | | | | | | | | | | | | | | | | | | | | |
|------------------|----|----|---------|---------|---------|---------|-----------|-----------|-----------|-----------|----|----|----|----|----|----|--------------|-------------|-------------|-------------|---|---|---|----|----|----|----|
| 27 | 26 | 25 | 24 | 23 | 22 | 21 | 20 | 19 | 18 | 17 | 16 | 15 | 14 | 13 | 12 | 11 | 10 | 9 | 8 | 7 | 6 | 5 | 4 | 3 | 2 | 1 | 0 |
| | | | | | | Bk[1:0] | | | | Row[10:0] | | | | | | | | | | Column[7:0] | | | | | | | M0 |
| | | | | | Bk[1:0] | | | | Row[10:0] | | | | | | | | | | Column[8:0] | | | | | | | M0 | |
| | | | | Bk[1:0] | | | | Row[10:0] | | | | | | | | | | Column[9:0] | | | | | | | M0 | | |
| | | | Bk[1:0] | | | | Row[10:0] | | | | | | | | | | Column[10:0] | | | | | | | M0 | | | |

Table 21-6. SDRAM Configuration Mapping: 4K Rows, 256/512/1024/2048 Columns

| CPU Address Line | | | | | | | | | | | | | | | | | | | | | | | | | | | |
|------------------|----|---------|---------|---------|---------|-----------|-----------|-----------|-----------|----|----|----|----|----|----|--------------|-------------|-------------|-------------|---|---|---|----|----|----|----|---|
| 27 | 26 | 25 | 24 | 23 | 22 | 21 | 20 | 19 | 18 | 17 | 16 | 15 | 14 | 13 | 12 | 11 | 10 | 9 | 8 | 7 | 6 | 5 | 4 | 3 | 2 | 1 | 0 |
| | | | | | Bk[1:0] | | | | Row[11:0] | | | | | | | | | | Column[7:0] | | | | | | | M0 | |
| | | | | Bk[1:0] | | | | Row[11:0] | | | | | | | | | | Column[8:0] | | | | | | | M0 | | |
| | | | Bk[1:0] | | | | Row[11:0] | | | | | | | | | | Column[9:0] | | | | | | | M0 | | | |
| | | Bk[1:0] | | | | Row[11:0] | | | | | | | | | | Column[10:0] | | | | | | | M0 | | | | |

Table 21-7. SDRAM Configuration Mapping: 8K Rows, 256/512/1024/2048 Columns

| CPU Address Line | | | | | | | | | | | | | | | | | | | | | | | | | | | |
|------------------|---------|---------|---------|---------|-----------|-----------|-----------|-----------|----|----|----|----|----|----|--------------|-------------|-------------|-------------|---|---|---|----|----|----|----|---|---|
| 27 | 26 | 25 | 24 | 23 | 22 | 21 | 20 | 19 | 18 | 17 | 16 | 15 | 14 | 13 | 12 | 11 | 10 | 9 | 8 | 7 | 6 | 5 | 4 | 3 | 2 | 1 | 0 |
| | | | | Bk[1:0] | | | | Row[12:0] | | | | | | | | | | Column[7:0] | | | | | | | M0 | | |
| | | | Bk[1:0] | | | | Row[12:0] | | | | | | | | | | Column[8:0] | | | | | | | M0 | | | |
| | | Bk[1:0] | | | | Row[12:0] | | | | | | | | | | Column[9:0] | | | | | | | M0 | | | | |
| | Bk[1:0] | | | | Row[12:0] | | | | | | | | | | Column[10:0] | | | | | | | M0 | | | | | |

- Notes: 1. M0 is the byte address inside a 16-bit half-word.
 4. Bk[1] = BA1, Bk[0] = BA0.

21.4 Product Dependencies

21.4.1 SDRAM Device Initialization

The initialization sequence is generated by software. The SDRAM devices are initialized by the following sequence:

1. SDRAM features must be set in the configuration register: asynchronous timings (TRC, TRAS, etc.), number of columns, rows, CAS latency, and the data bus width.
2. For mobile SDRAM, temperature-compensated self refresh (TCSR), drive strength (DS) and partial array self refresh (PASR) must be set in the Low Power Register.
3. The SDRAM memory type must be set in the Memory Device Register.
4. A minimum pause of 200 μ s is provided to precede any signal toggle.
5. ⁽¹⁾A NOP command is issued to the SDRAM devices. The application must set Mode to 1 in the Mode Register and perform a write access to any SDRAM address.
6. An All Banks Precharge command is issued to the SDRAM devices. The application must set Mode to 2 in the Mode Register and perform a write access to any SDRAM address.
7. Eight auto-refresh (CBR) cycles are provided. The application must set the Mode to 4 in the Mode Register and perform a write access to any SDRAM location eight times.
8. A Mode Register set (MRS) cycle is issued to program the parameters of the SDRAM devices, in particular CAS latency and burst length. The application must set Mode to 3 in the Mode Register and perform a write access to the SDRAM. The write address must be chosen so that BA[1:0] are set to 0. For example, with a 16-bit 128 MB SDRAM (12 rows, 9 columns, 4 banks) bank address, the SDRAM write access should be done at the address 0x20000000.
9. For mobile SDRAM initialization, an Extended Mode Register set (EMRS) cycle is issued to program the SDRAM parameters (TCSR, PASR, DS). The application must set Mode to 5 in the Mode Register and perform a write access to the SDRAM. The write address must be chosen so that BA[1] or BA[0] are set to 1. For example, with a 16-bit 128 MB SDRAM, (12 rows, 9 columns, 4 banks) bank address the SDRAM write access should be done at the address 0x20800000 or 0x20400000.
10. The application must go into Normal Mode, setting Mode to 0 in the Mode Register and performing a write access at any location in the SDRAM.
11. Write the refresh rate into the count field in the SDRAMC Refresh Timer register. (Refresh rate = delay between refresh cycles). The SDRAM device requires a refresh every 15.625 μ s or 7.81 μ s. With a 100 MHz frequency, the Refresh Timer Counter Register must be set with the value 1562(15.652 μ s x 100 MHz) or 781(7.81 μ s x 100 MHz).

After initialization, the SDRAM devices are fully functional.

Note: 1. It is strongly recommended to respect the instructions stated in [Step 5](#) of the initialization process in order to be certain that the subsequent commands issued by the SDRAMC will be taken into account.

Figure 21-1. SDRAM Device Initialization Sequence

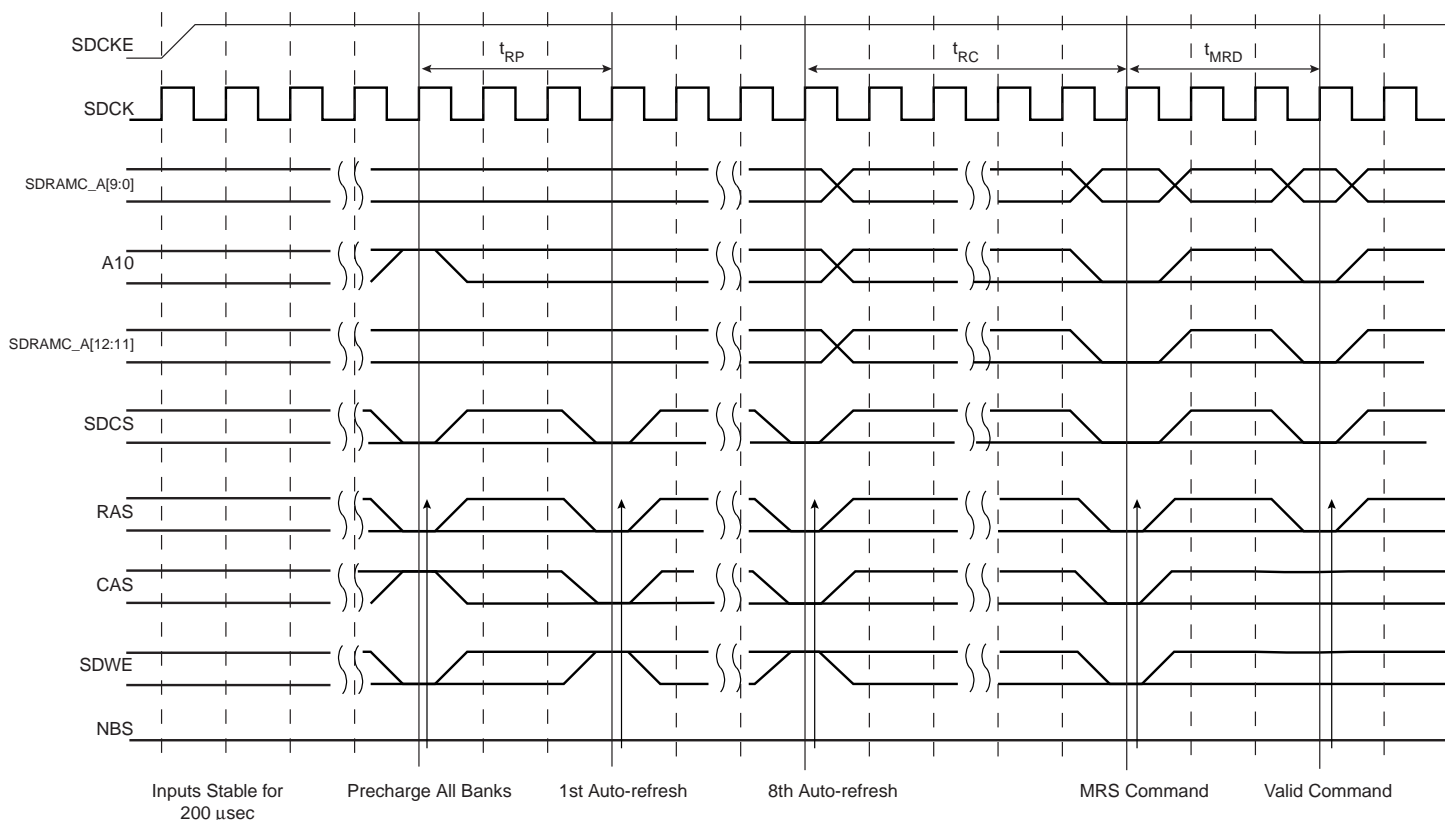

21.4.2 I/O Lines

The pins used for interfacing the SDRAM Controller may be multiplexed with the PIO lines. The programmer must first program the PIO controller to assign the SDRAM Controller pins to their peripheral function. If I/O lines of the SDRAM Controller are not used by the application, they can be used for other purposes by the PIO Controller.

21.4.3 Interrupt

The SDRAM Controller interrupt (Refresh Error notification) is connected to the Memory Controller. This interrupt may be ORed with other System Peripheral interrupt lines and is finally provided as the System Interrupt Source (Source 1) to the AIC (Advanced Interrupt Controller).

Using the SDRAM Controller interrupt requires the AIC to be programmed first.

21.5 Functional Description

21.5.1 SDRAM Controller Write Cycle

The SDRAM Controller allows burst access or single access. In both cases, the SDRAM controller keeps track of the active row in each bank, thus maximizing performance. To initiate a burst access, the SDRAM Controller uses the transfer type signal provided by the master requesting the access. If the next access is a sequential write access, writing to the SDRAM device is carried out. If the next access is a write-sequential access, but the current access is to a boundary page, or if the next access is in another row, then the SDRAM Controller generates a precharge command, activates the new row and initiates a write command. To comply with SDRAM timing parameters, additional clock cycles are inserted between precharge/active (t_{RP}) commands and active/write (t_{RCD}) commands. For definition of these timing parameters, refer to the “[SDRAMC Configuration Register](#)” on page 208. This is described in [Figure 21-2](#) below.

Figure 21-2. Write Burst, 32-bit SDRAM Access

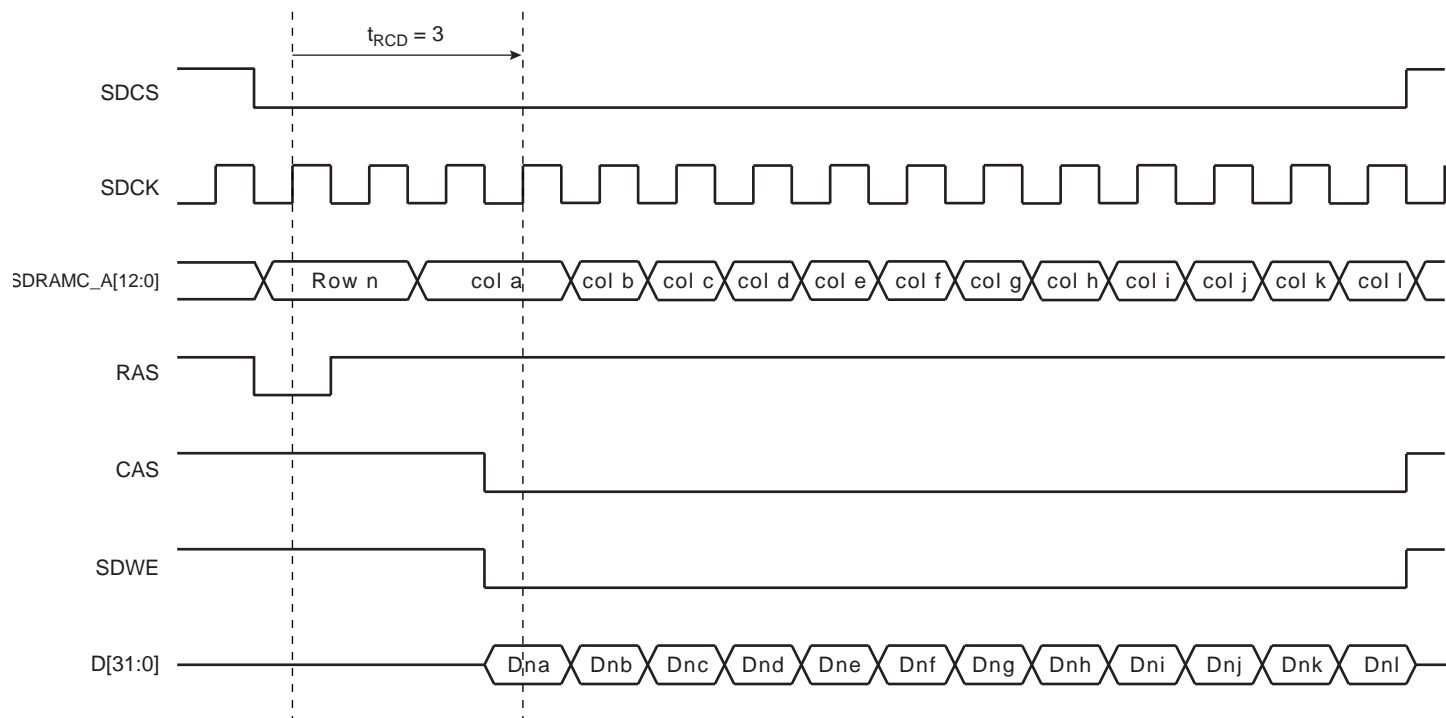

21.5.2 SDRAM Controller Read Cycle

The SDRAM Controller allows burst access, incremental burst of unspecified length or single access. In all cases, the SDRAM Controller keeps track of the active row in each bank, thus maximizing performance of the SDRAM. If row and bank addresses do not match the previous row/bank address, then the SDRAM controller automatically generates a precharge command, activates the new row and starts the read command. To comply with the SDRAM timing parameters, additional clock cycles on SDCK are inserted between precharge and active commands (t_{RP}) and between active and read command (t_{RCD}). These two parameters are set in the configuration register of the SDRAM Controller. After a read command, additional wait states are generated to comply with the CAS latency (1, 2 or 3 clock delays specified in the configuration register).

For a single access or an incremented burst of unspecified length, the SDRAM Controller anticipates the next access. While the last value of the column is returned by the SDRAM Controller on the bus, the SDRAM Controller anticipates the read to the next column and thus anticipates the CAS latency. This reduces the effect of the CAS latency on the internal bus.

For burst access of specified length (4, 8, 16 words), access is not anticipated. This case leads to the best performance. If the burst is broken (border, busy mode, etc.), the next access is handled as an incrementing burst of unspecified length.

Figure 21-3. Read Burst, 32-bit SDRAM Access

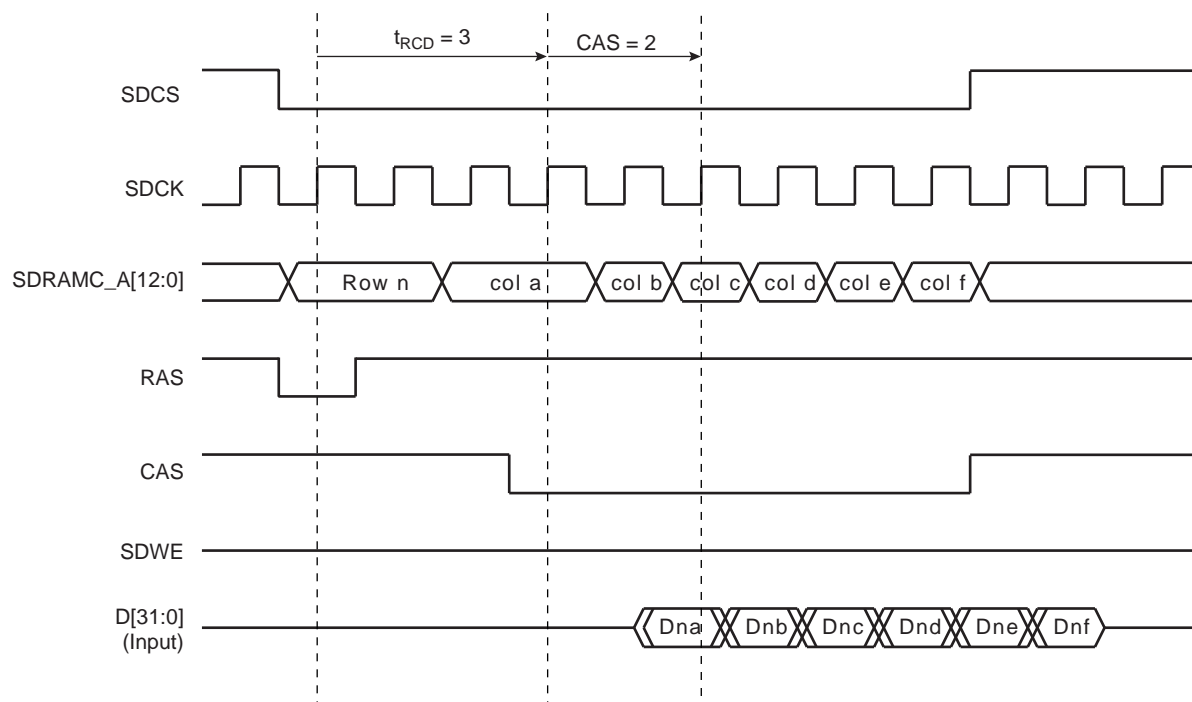

21.5.3 Border Management

When the memory row boundary has been reached, an automatic page break is inserted. In this case, the SDRAM controller generates a precharge command, activates the new row and initiates a read or write command. To comply with SDRAM timing parameters, an additional clock cycle is inserted between the precharge/active (t_{RP}) command and the active/read (t_{RCD}) command. This is described in Figure 21-4 below.

Figure 21-4. Read Burst with Boundary Row Access

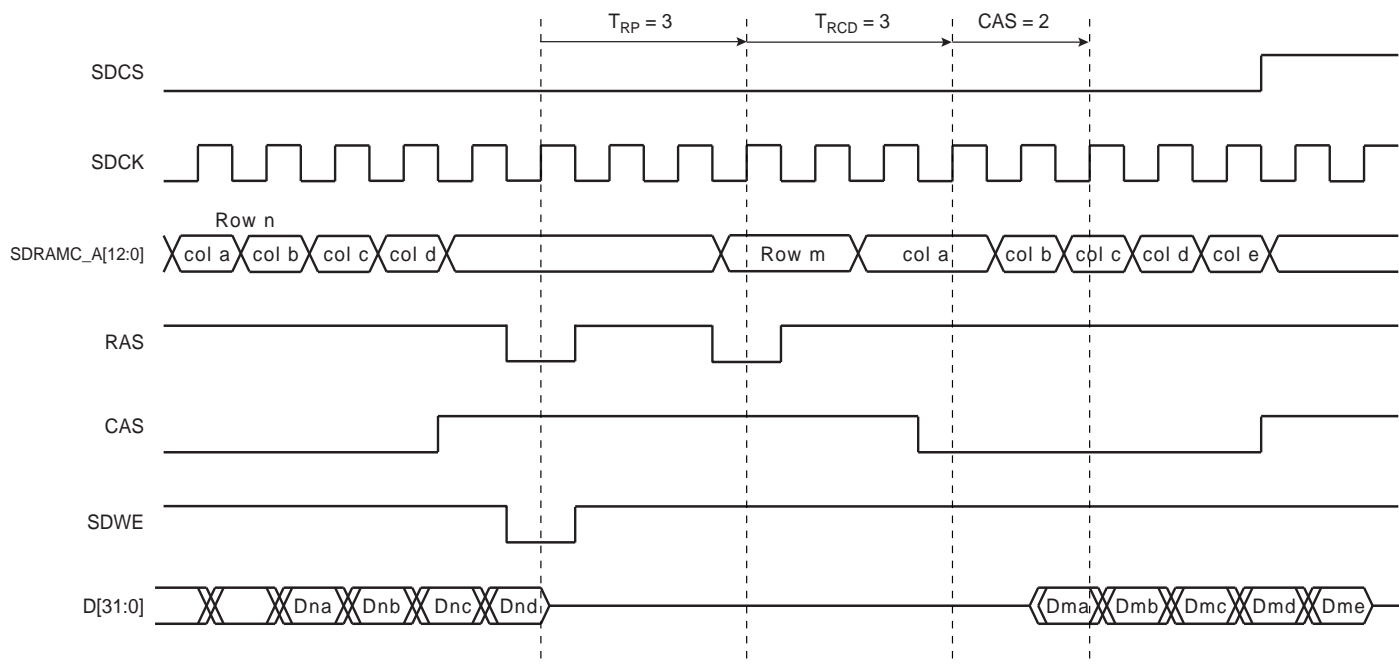

21.5.4 SDRAM Controller Refresh Cycles

An auto-refresh command is used to refresh the SDRAM device. Refresh addresses are generated internally by the SDRAM device and incremented after each auto-refresh automatically. The SDRAM Controller generates these auto-refresh commands periodically. An internal timer is loaded with the value in the register SDRAMC_TR that indicates the number of clock cycles between refresh cycles.

A refresh error interrupt is generated when the previous auto-refresh command did not perform. It is acknowledged by reading the Interrupt Status Register (SDRAMC_ISR).

When the SDRAM Controller initiates a refresh of the SDRAM device, internal memory accesses are not delayed. However, if the CPU tries to access the SDRAM, the slave indicates that the device is busy and the master is held by a wait signal. See [Figure 21-5](#).

Figure 21-5. Refresh Cycle Followed by a Read Access

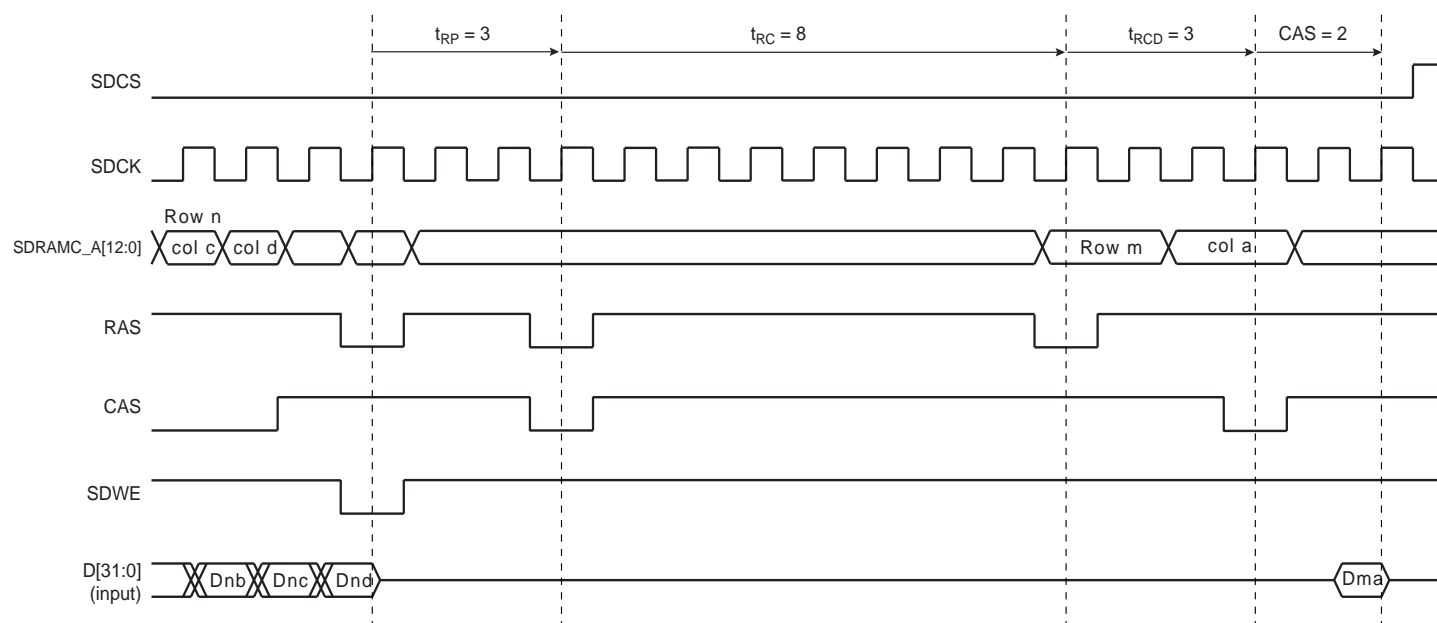

21.5.5 Power Management

Three low-power modes are available:

- Self-refresh Mode: The SDRAM executes its own Auto-refresh cycle without control of the SDRAM Controller. Current drained by the SDRAM is very low.
- Powerdown Mode: Auto-refresh cycles are controlled by the SDRAM Controller. Between auto-refresh cycles, the SDRAM is in powerdown. Current drained in Powerdown mode is higher than in Self-refresh Mode.
- Deep Powerdown Mode: (Only available with Mobile SDRAM) The SDRAM contents are lost, but the SDRAM does not drain any current.

The SDRAM Controller activates one low-power mode as soon as the SDRAM device is not selected. It is possible to delay the entry in self-refresh and powerdown mode after the last access by programming a timeout value in the Low Power Register.

21.5.5.1 Self-refresh Mode

This mode is selected by programming the LPCB field to 1 in the SDRAMC Low Power Register. In self-refresh mode, the SDRAM device retains data without external clocking and provides its own internal clocking, thus performing its own auto-refresh cycles. All the inputs to the SDRAM device become “don't care” except SDCKE, which remains low. As soon as the SDRAM device is selected, the SDRAM Controller provides a sequence of commands and exits self-refresh mode.

Some low-power SDRAMs (e.g., mobile SDRAM) can refresh only one quarter or a half quarter or all banks of the SDRAM array. This feature reduces the self-refresh current. To configure this feature, Temperature Compensated Self Refresh (TCSR), Partial Array Self Refresh (PASR) and Drive Strength (DS) parameters must be set in the Low Power Register and transmitted to the low-power SDRAM during initialization.

The SDRAM device must remain in self-refresh mode for a minimum period of t_{RAS} and may remain in self-refresh mode for an indefinite period. This is described in [Figure 21-6](#).

Figure 21-6. Self-refresh Mode Behavior

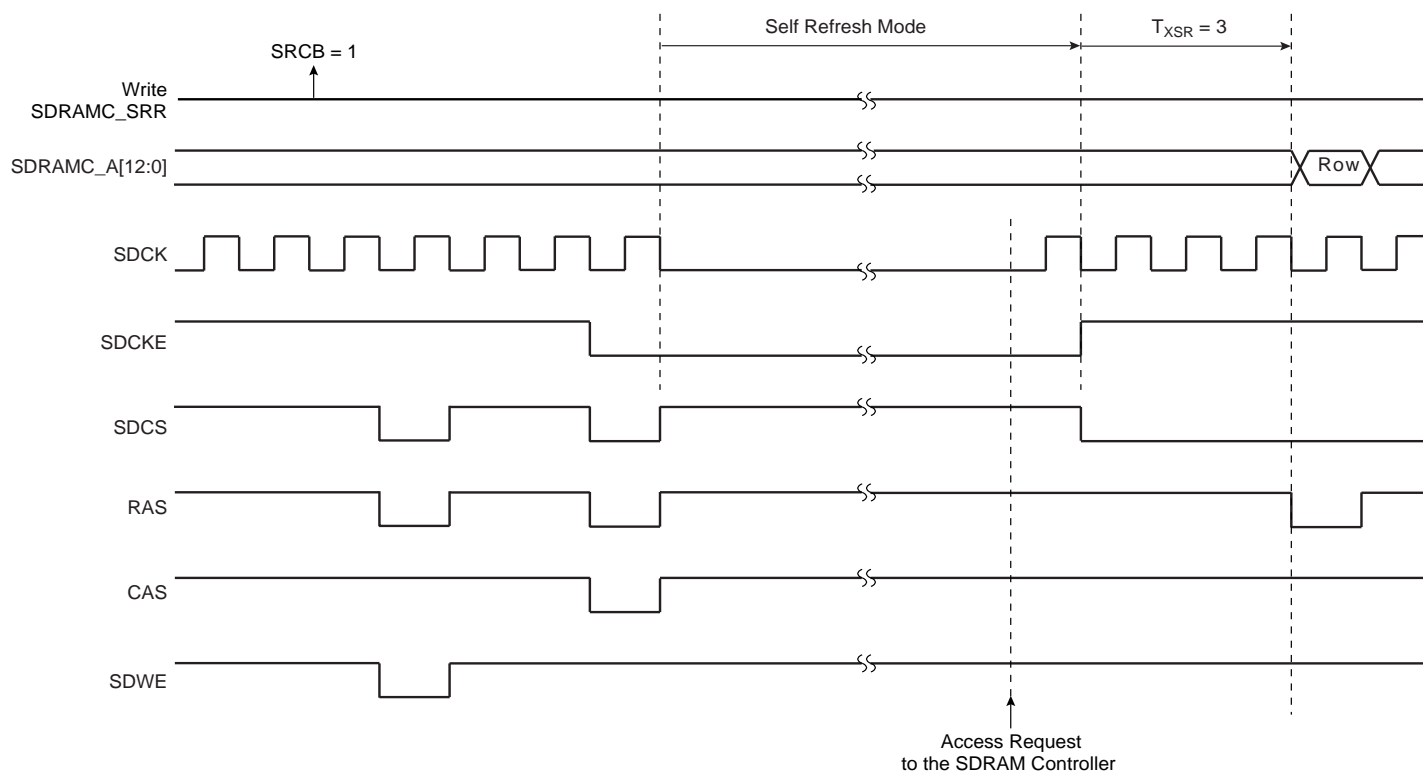

21.5.5.2 Low-power Mode

This mode is selected by programming the LPCB field to 2 in the SDRAMC Low Power Register. Power consumption is greater than in self-refresh mode. All the input and output buffers of the SDRAM device are deactivated except SDCKE, which remains low. In contrast to self-refresh mode, the SDRAM device cannot remain in low-power mode longer than the refresh period (64 ms for a whole device refresh operation). As no auto-refresh operations are performed by the SDRAM itself, the SDRAM Controller carries out the refresh operation. The exit procedure is faster than in self-refresh mode.

This is described in [Figure 21-7](#).

Figure 21-7. Low-power Mode Behavior

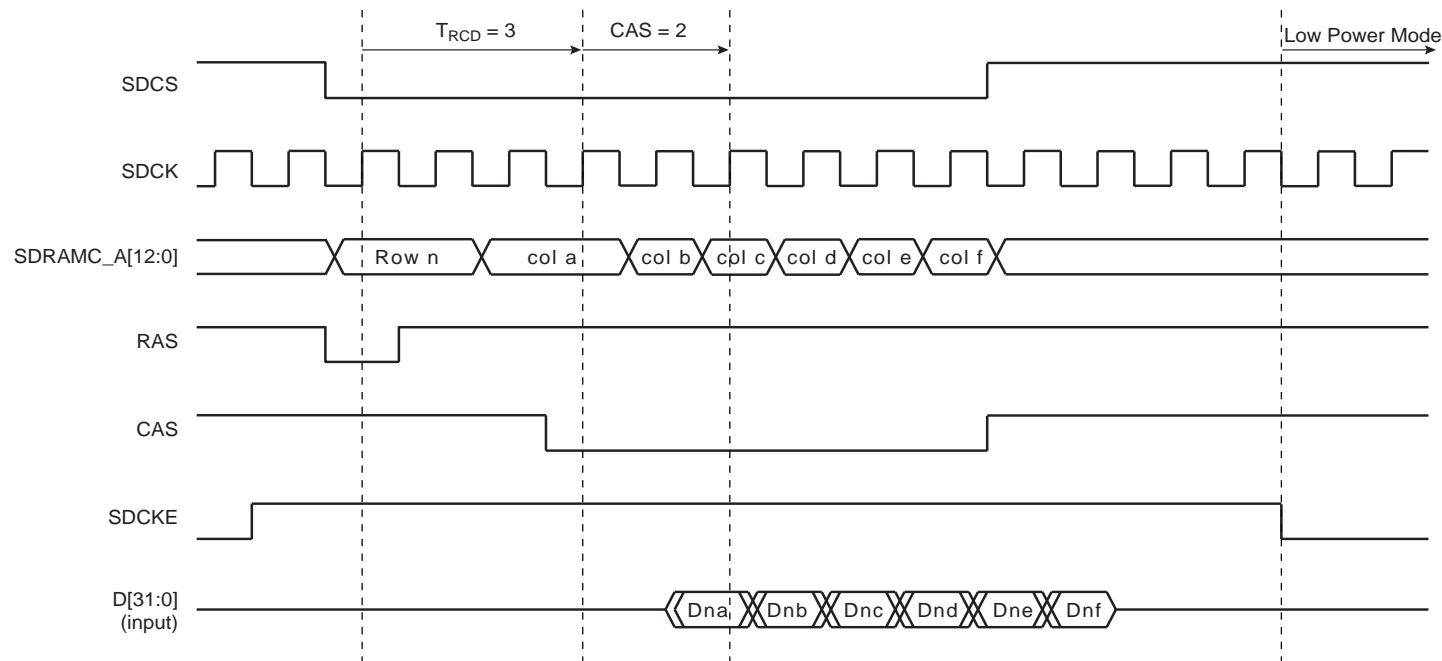

21.5.5.3 Deep Powerdown Mode

This mode is selected by programming the LPCB field to 3 in the SDRAMC Low Power Register. When this mode is activated, all internal voltage generators inside the SDRAM are stopped and all data is lost.

When this mode is enabled, the application must not access to the SDRAM until a new initialization sequence is done (See “[SDRAM Device Initialization](#)” on page 196).

This is described in [Figure 21-8](#).

Figure 21-8. Deep Powerdown Mode Behavior

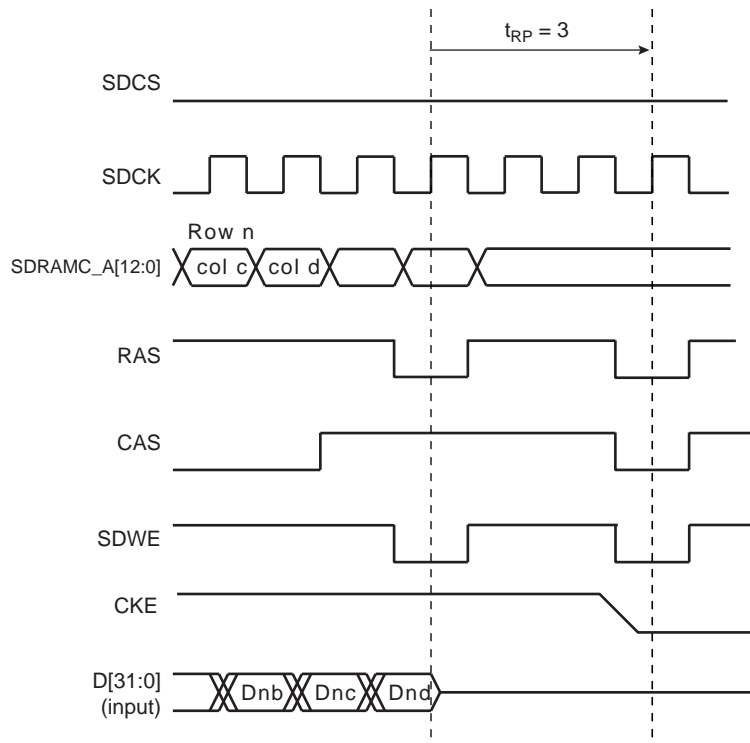

21.6 SDRAM Controller (SDRAMC) User Interface

Table 21-8. Register Mapping

| Offset | Register | Name | Access | Reset |
|-----------|-----------------------------------|------------|------------|------------|
| 0x00 | SDRAMC Mode Register | SDRAMC_MR | Read/Write | 0x00000000 |
| 0x04 | SDRAMC Refresh Timer Register | SDRAMC_TR | Read/Write | 0x00000000 |
| 0x08 | SDRAMC Configuration Register | SDRAMC_CR | Read/Write | 0x852372C0 |
| 0x10 | SDRAMC Low Power Register | SDRAMC_LPR | Read/Write | 0x0 |
| 0x14 | SDRAMC Interrupt Enable Register | SDRAMC_IER | Write-only | – |
| 0x18 | SDRAMC Interrupt Disable Register | SDRAMC_IDR | Write-only | – |
| 0x1C | SDRAMC Interrupt Mask Register | SDRAMC_IMR | Read-only | 0x0 |
| 0x20 | SDRAMC Interrupt Status Register | SDRAMC_ISR | Read-only | 0x0 |
| 0x24 | SDRAMC Memory Device Register | SDRAMC_MDR | Read/Write | 0x0 |
| 0x28–0xFC | Reserved | – | – | – |

21.6.1 SDRAMC Mode Register

Register SDRAMC_MR

Address: 0xFFFFEA00

Access: Read/Write

| | | | | | | | |
|----|----|----|----|----|------|----|----|
| 31 | 30 | 29 | 28 | 27 | 26 | 25 | 24 |
| – | – | – | – | – | – | – | – |
| 23 | 22 | 21 | 20 | 19 | 18 | 17 | 16 |
| – | – | – | – | – | – | – | – |
| 15 | 14 | 13 | 12 | 11 | 10 | 9 | 8 |
| – | – | – | – | – | – | – | – |
| 7 | 6 | 5 | 4 | 3 | 2 | 1 | 0 |
| – | – | – | – | – | MODE | | |

• MODE: SDRAMC Command Mode

This field defines the command issued by the SDRAM Controller when the SDRAM device is accessed.

| Value | | | Description |
|-------|---|---|--|
| 0 | 0 | 0 | Normal mode. Any access to the SDRAM is decoded normally. To activate this mode, command must be followed by a write to the SDRAM. |
| 0 | 0 | 1 | The SDRAM Controller issues a NOP command when the SDRAM device is accessed regardless of the cycle. To activate this mode, command must be followed by a write to the SDRAM. |
| 0 | 1 | 0 | The SDRAM Controller issues an “All Banks Precharge” command when the SDRAM device is accessed regardless of the cycle. To activate this mode, command must be followed by a write to the SDRAM. |
| 0 | 1 | 1 | The SDRAM Controller issues a “Load Mode Register” command when the SDRAM device is accessed regardless of the cycle. To activate this mode, command must be followed by a write to the SDRAM. |
| 1 | 0 | 0 | The SDRAM Controller issues an “Auto-Refresh” Command when the SDRAM device is accessed regardless of the cycle. Previously, an “All Banks Precharge” command must be issued. To activate this mode, command must be followed by a write to the SDRAM. |
| 1 | 0 | 1 | The SDRAM Controller issues an “Extended Load Mode Register” command when the SDRAM device is accessed regardless of the cycle. To activate this mode, the “Extended Load Mode Register” command must be followed by a write to the SDRAM. The write in the SDRAM must be done in the appropriate bank; most low-power SDRAM devices use the bank 1. |
| 1 | 1 | 0 | Deep powerdown mode. Enters deep powerdown mode. |

21.6.2 SDRAMC Refresh Timer Register

Register: SDRAMC_TR

Address: 0xFFFFEA04

Access: Read/Write

| | | | | | | | |
|-------|----|----|----|-------|----|----|----|
| 31 | 30 | 29 | 28 | 27 | 26 | 25 | 24 |
| – | – | – | – | – | – | – | – |
| 23 | 22 | 21 | 20 | 19 | 18 | 17 | 16 |
| – | – | – | – | – | – | – | – |
| 15 | 14 | 13 | 12 | 11 | 10 | 9 | 8 |
| – | – | – | – | COUNT | | | |
| 7 | 6 | 5 | 4 | 3 | 2 | 1 | 0 |
| COUNT | | | | | | | |

- **COUNT: SDRAMC Refresh Timer Count**

This 12-bit field is loaded into a timer that generates the refresh pulse. Each time the refresh pulse is generated, a refresh burst is initiated. The value to be loaded depends on the SDRAMC clock frequency (MCK: Master Clock), the refresh rate of the SDRAM device and the refresh burst length where 15.6 μ s per row is a typical value for a burst of length one.

To refresh the SDRAM device, this 12-bit field must be written. If this condition is not satisfied, no refresh command is issued and no refresh of the SDRAM device is carried out.

21.6.3 SDRAMC Configuration Register

Register: SDRAMC_CR

Address: 0xFFFFEA08

Access: Read/Write

| | | | | | | | |
|------|-----|----|----|------|----|----|----|
| 31 | 30 | 29 | 28 | 27 | 26 | 25 | 24 |
| TXSR | | | | TRAS | | | |
| 23 | 22 | 21 | 20 | 19 | 18 | 17 | 16 |
| TRCD | | | | TRP | | | |
| 15 | 14 | 13 | 12 | 11 | 10 | 9 | 8 |
| TRC | | | | TWR | | | |
| 7 | 6 | 5 | 4 | 3 | 2 | 1 | 0 |
| DBW | CAS | | NB | NR | | NC | |

- NC: Number of Column Bits**

Reset value is 8 column bits.

| Value | | Column Bits |
|-------|---|-------------|
| 0 | 0 | 8 |
| 0 | 1 | 9 |
| 1 | 0 | 10 |
| 1 | 1 | 11 |

- NR: Number of Row Bits**

Reset value is 11 row bits.

| Value | | Row Bits |
|-------|---|----------|
| 0 | 0 | 11 |
| 0 | 1 | 12 |
| 1 | 0 | 13 |
| 1 | 1 | Reserved |

- NB: Number of Banks**

Reset value is two banks.

| Value | | Number of Banks |
|-------|--|-----------------|
| 0 | | 2 |
| 1 | | 4 |

- **CAS: CAS Latency**

Reset value is two cycles.

In the SDRAMC, only a CAS latency of one, two and three cycles is managed.

| Value | | CAS Latency (Cycles) |
|-------|---|----------------------|
| 0 | 0 | Reserved |
| 0 | 1 | 1 |
| 1 | 0 | 2 |
| 1 | 1 | 3 |

- **DBW: Data Bus Width**

Reset value is 16 bits

0: Data bus width is 32 bits.

1: Data bus width is 16 bits.

- **TWR: Write Recovery Delay**

Reset value is two cycles.

This field defines the Write Recovery Time in number of cycles. Number of cycles is between 0 and 15.

- **TRC: Row Cycle Delay**

Reset value is seven cycles.

This field defines the delay between a Refresh and an Activate Command in number of cycles. Number of cycles is between 0 and 15.

- **TRP: Row Precharge Delay**

Reset value is three cycles.

This field defines the delay between a Precharge Command and another Command in number of cycles. Number of cycles is between 0 and 15.

- **TRCD: Row to Column Delay**

Reset value is two cycles.

This field defines the delay between an Activate Command and a Read/Write Command in number of cycles. Number of cycles is between 0 and 15.

- **TRAS: Active to Precharge Delay**

Reset value is five cycles.

This field defines the delay between an Activate Command and a Precharge Command in number of cycles. Number of cycles is between 0 and 15.

- **TXSR: Exit Self Refresh to Active Delay**

Reset value is eight cycles.

This field defines the delay between SCKE set high and an Activate Command in number of cycles. Number of cycles is between 0 and 15

21.6.4 SDRAMC Low Power Register

Register: SDRAMC_LPR

Address: 0xFFFFEA10

Access: Read/Write

| | | | | | | | |
|----|------|---------|----|----|----|------|----|
| 31 | 30 | 29 | 28 | 27 | 26 | 25 | 24 |
| – | – | – | – | – | – | – | – |
| 23 | 22 | 21 | 20 | 19 | 18 | 17 | 16 |
| – | – | – | – | – | – | – | – |
| 15 | 14 | 13 | 12 | 11 | 10 | 9 | 8 |
| – | – | TIMEOUT | | DS | | TCSR | |
| 7 | 6 | 5 | 4 | 3 | 2 | 1 | 0 |
| – | PASR | | | – | – | LPCB | |

• LPCB: Low-power Configuration Bits

| Value | Description |
|-------|---|
| 00 | Low Power Feature is inhibited: no Powerdown, Self-refresh or Deep Powerdown command is issued to the SDRAM device. |
| 01 | The SDRAM Controller issues a Self-refresh command to the SDRAM device, the SDCLK clock is deactivated and the SDCKE signal is set low. The SDRAM device leaves the Self Refresh Mode when accessed and enters it after the access. |
| 10 | The SDRAM Controller issues a Powerdown Command to the SDRAM device after each access, the SDCKE signal is set to low. The SDRAM device leaves the Powerdown Mode when accessed and enters it after the access. |
| 11 | The SDRAM Controller issues a Deep Powerdown command to the SDRAM device. This mode is unique to low-power SDRAM. |

• PASR: Partial Array Self-refresh (only for low-power SDRAM)

PASR parameter is transmitted to the SDRAM during initialization to specify whether only one quarter, one half or all banks of the SDRAM array are enabled. Disabled banks are not refreshed in self-refresh mode. This parameter must be set according to the SDRAM device specification.

• TCSR: Temperature Compensated Self-Refresh (only for low-power SDRAM)

TCSR parameter is transmitted to the SDRAM during initialization to set the refresh interval during self-refresh mode depending on the temperature of the low-power SDRAM. This parameter must be set according to the SDRAM device specification.

• DS: Drive Strength (only for low-power SDRAM)

DS parameter is transmitted to the SDRAM during initialization to select the SDRAM strength of data output. This parameter must be set according to the SDRAM device specification.

• TIMEOUT: Time to define when low-power mode is enabled

| Value | Description |
|-------|--|
| 00 | The SDRAM controller activates the SDRAM low-power mode immediately after the end of the last transfer. |
| 01 | The SDRAM controller activates the SDRAM low-power mode 64 clock cycles after the end of the last transfer. |
| 10 | The SDRAM controller activates the SDRAM low-power mode 128 clock cycles after the end of the last transfer. |
| 11 | Reserved. |

21.6.5 SDRAMC Interrupt Enable Register

Register: SDRAMC_IER

Address: 0xFFFFEA14

Access: Write-only

| | | | | | | | |
|----|----|----|----|----|----|----|-----|
| 31 | 30 | 29 | 28 | 27 | 26 | 25 | 24 |
| – | – | – | – | – | – | – | – |
| 23 | 22 | 21 | 20 | 19 | 18 | 17 | 16 |
| – | – | – | – | – | – | – | – |
| 15 | 14 | 13 | 12 | 11 | 10 | 9 | 8 |
| – | – | – | – | – | – | – | – |
| 7 | 6 | 5 | 4 | 3 | 2 | 1 | 0 |
| – | – | – | – | – | – | – | RES |

- **RES: Refresh Error Status**

0: No effect.

1: Enables the refresh error interrupt.

21.6.6 SDRAMC Interrupt Disable Register

Register: SDRAMC_IDR

Address: 0xFFFFEA18

Access: Write-only

| | | | | | | | |
|----|----|----|----|----|----|----|-----|
| 31 | 30 | 29 | 28 | 27 | 26 | 25 | 24 |
| – | – | – | – | – | – | – | – |
| 23 | 22 | 21 | 20 | 19 | 18 | 17 | 16 |
| – | – | – | – | – | – | – | – |
| 15 | 14 | 13 | 12 | 11 | 10 | 9 | 8 |
| – | – | – | – | – | – | – | – |
| 7 | 6 | 5 | 4 | 3 | 2 | 1 | 0 |
| – | – | – | – | – | – | – | RES |

- **RES: Refresh Error Status**

0: No effect.

1: Disables the refresh error interrupt.

21.6.7 SDRAMC Interrupt Mask Register

Register: SDRAMC_IMR

Address: 0xFFFFEA1C

Access: Read-only

| | | | | | | | |
|----|----|----|----|----|----|----|-----|
| 31 | 30 | 29 | 28 | 27 | 26 | 25 | 24 |
| – | – | – | – | – | – | – | – |
| 23 | 22 | 21 | 20 | 19 | 18 | 17 | 16 |
| – | – | – | – | – | – | – | – |
| 15 | 14 | 13 | 12 | 11 | 10 | 9 | 8 |
| – | – | – | – | – | – | – | – |
| 7 | 6 | 5 | 4 | 3 | 2 | 1 | 0 |
| – | – | – | – | – | – | – | RES |

- **RES: Refresh Error Status**

0: The refresh error interrupt is disabled.

1: The refresh error interrupt is enabled.

21.6.8 SDRAMC Interrupt Status Register

Register: SDRAMC_ISR

Address: 0xFFFFEA20

Access: Read-only

| | | | | | | | |
|----|----|----|----|----|----|----|-----|
| 31 | 30 | 29 | 28 | 27 | 26 | 25 | 24 |
| – | – | – | – | – | – | – | – |
| 23 | 22 | 21 | 20 | 19 | 18 | 17 | 16 |
| – | – | – | – | – | – | – | – |
| 15 | 14 | 13 | 12 | 11 | 10 | 9 | 8 |
| – | – | – | – | – | – | – | – |
| 7 | 6 | 5 | 4 | 3 | 2 | 1 | 0 |
| – | – | – | – | – | – | – | RES |

- **RES: Refresh Error Status**

0: No refresh error has been detected since the register was last read.

1: A refresh error has been detected since the register was last read.

21.6.9 SDRAMC Memory Device Register

Register: SDRAMC_MDR

Address: 0xFFFFEA24

Access: Read/Write

| | | | | | | | |
|----|----|----|----|----|----|----|----|
| 31 | 30 | 29 | 28 | 27 | 26 | 25 | 24 |
| – | – | – | – | – | – | – | – |
| 23 | 22 | 21 | 20 | 19 | 18 | 17 | 16 |
| – | – | – | – | – | – | – | – |
| 15 | 14 | 13 | 12 | 11 | 10 | 9 | 8 |
| – | – | – | – | – | – | – | – |
| 7 | 6 | 5 | 4 | 3 | 2 | 1 | 0 |
| – | – | – | – | – | – | MD | |

• **MD: Memory Device Type**

| Value | Description |
|-------|-----------------|
| 00 | SDRAM |
| 01 | Low-power SDRAM |
| 10 | Reserved |
| 11 | Reserved. |

22. Peripheral DMA Controller (PDC)

22.1 Overview

The Peripheral DMA Controller (PDC) transfers data between on-chip serial peripherals and the on- and/or off-chip memories. The link between the PDC and a serial peripheral is operated by the AHB to ABP bridge.

The PDC contains 19 channels. The full-duplex peripherals feature 18 mono directional channels used in pairs (transmit only or receive only). The half-duplex peripherals feature 1 bi-directional channels.

The user interface of each PDC channel is integrated into the user interface of the peripheral it serves. The user interface of mono directional channels (receive only or transmit only), contains two 32-bit memory pointers and two 16-bit counters, one set (pointer, counter) for current transfer and one set (pointer, counter) for next transfer. The bi-directional channel user interface contains four 32-bit memory pointers and four 16-bit counters. Each set (pointer, counter) is used by current transmit, next transmit, current receive and next receive.

Using the PDC removes processor overhead by reducing its intervention during the transfer. This significantly reduces the number of clock cycles required for a data transfer, which improves microcontroller performance.

To launch a transfer, the peripheral triggers its associated PDC channels by using transmit and receive signals. When the programmed data is transferred, an end of transfer interrupt is generated by the peripheral itself.

22.2 Block Diagram

Figure 22-1. Block Diagram

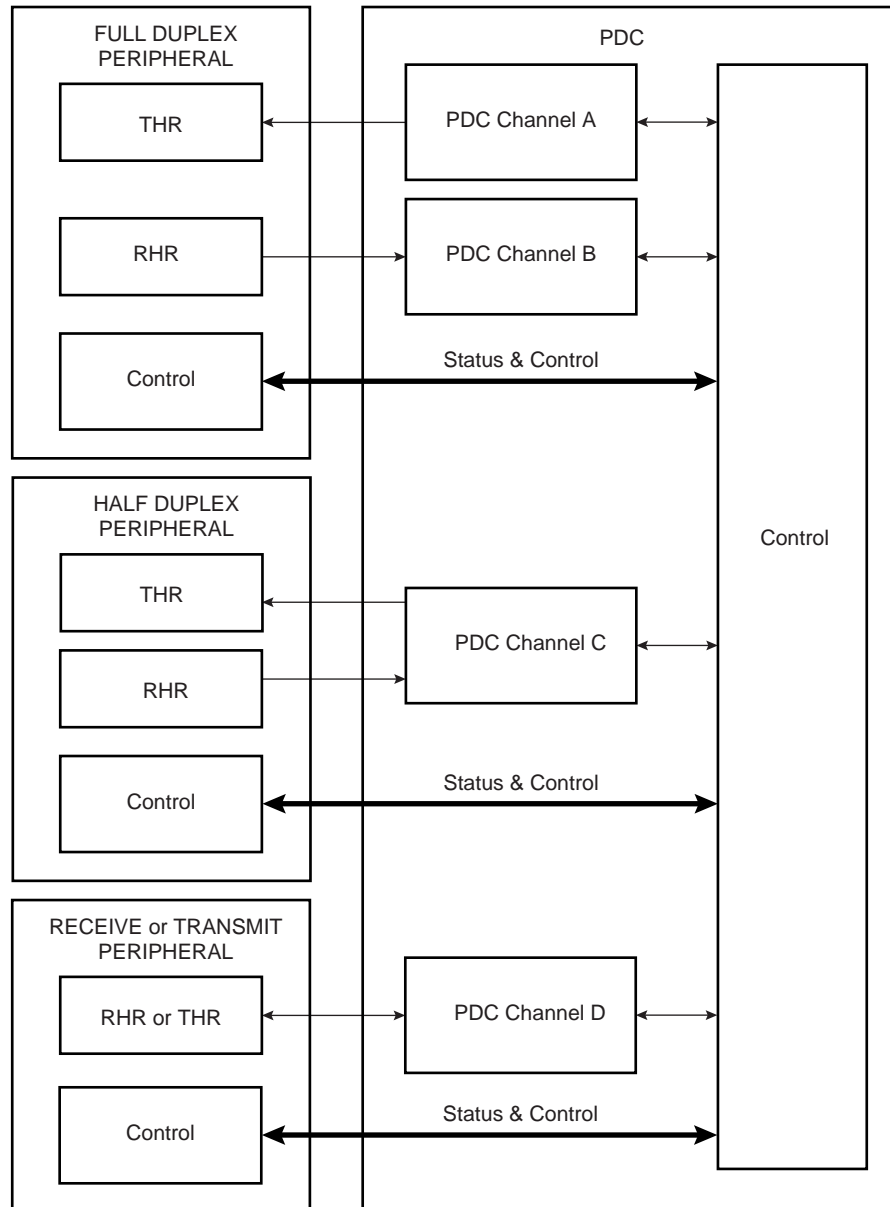

22.3 Functional Description

22.3.1 Configuration

The PDC channel user interface enables the user to configure and control data transfers for each channel. The user interface of each PDC channel is integrated into the associated peripheral user interface.

The user interface of a serial peripheral, whether it is full or half duplex, contains four 32-bit pointers (RPR, RNPR, TPR, TNPR) and four 16-bit counter registers (RCR, RNCR, TCR, TNCR). However, the transmit and receive parts of each type are programmed differently: the transmit and receive parts of a full duplex peripheral can be programmed at the same time, whereas only one part (transmit or receive) of a half duplex peripheral can be programmed at a time.

32-bit pointers define the access location in memory for current and next transfer, whether it is for read (transmit) or write (receive). 16-bit counters define the size of current and next transfers. It is possible, at any moment, to read the number of transfers left for each channel.

The PDC has dedicated status registers which indicate if the transfer is enabled or disabled for each channel. The status for each channel is located in the associated peripheral status register. Transfers can be enabled and/or disabled by setting TXTEN/TXTDIS and RXTEN/RXTDIS in the peripheral's Transfer Control Register.

At the end of a transfer, the PDC channel sends status flags to its associated peripheral. These flags are visible in the peripheral status register (ENDRX, ENDTX, RXBUFF, and TXBUFE). Refer to [Section 22.3.3](#) and to the associated peripheral user interface.

22.3.2 Memory Pointers

Each full duplex peripheral is connected to the PDC by a receive channel and a transmit channel. Both channels have 32-bit memory pointers that point respectively to a receive area and to a transmit area in on- and/or off-chip memory.

Each half duplex peripheral is connected to the PDC by a bidirectional channel. This channel has two 32-bit memory pointers, one for current transfer and the other for next transfer. These pointers point to transmit or receive data depending on the operating mode of the peripheral.

Depending on the type of transfer (byte, half-word or word), the memory pointer is incremented respectively by 1, 2 or 4 bytes.

If a memory pointer address changes in the middle of a transfer, the PDC channel continues operating using the new address.

22.3.3 Transfer Counters

Each channel has two 16-bit counters, one for current transfer and the other one for next transfer. These counters define the size of data to be transferred by the channel. The current transfer counter is decremented first as the data addressed by current memory pointer starts to be transferred. When the current transfer counter reaches zero, the channel checks its next transfer counter. If the value of next counter is zero, the channel stops transferring data and sets the appropriate flag. But if the next counter value is greater than zero, the values of the next pointer/next counter are copied into the current pointer/current counter and the channel resumes the transfer whereas next pointer/next counter get zero/zero as values. At the end of this transfer the PDC channel sets the appropriate flags in the Peripheral Status Register.

The following list gives an overview of how status register flags behave depending on the counters' values:

- ENDRX flag is set when the PERIPH_RCR reaches zero.
- RXBUFF flag is set when both PERIPH_RCR and PERIPH_RNCR reach zero.
- ENDTX flag is set when the PERIPH_TCR reaches zero.
- TXBUFE flag is set when both PERIPH_TCR and PERIPH_TNCR reach zero.

These status flags are described in the Peripheral Status Register.

22.3.4 Data Transfers

The serial peripheral triggers its associated PDC channels' transfers using transmit enable (TXEN) and receive enable (RXEN) flags in the transfer control register integrated in the peripheral's user interface.

When the peripheral receives an external data, it sends a Receive Ready signal to its PDC receive channel which then requests access to the Matrix. When access is granted, the PDC receive channel starts reading the peripheral Receive Holding Register (RHR). The read data are stored in an internal buffer and then written to memory.

When the peripheral is about to send data, it sends a Transmit Ready to its PDC transmit channel which then requests access to the Matrix. When access is granted, the PDC transmit channel reads data from memory and puts them to Transmit Holding Register (THR) of its associated peripheral. The same peripheral sends data according to its mechanism.

22.3.5 PDC Flags and Peripheral Status Register

Each peripheral connected to the PDC sends out receive ready and transmit ready flags and the PDC sends back flags to the peripheral. All these flags are only visible in the Peripheral Status Register.

Depending on the type of peripheral, half or full duplex, the flags belong to either one single channel or two different channels.

22.3.5.1 Receive Transfer End

This flag is set when PERIPH_RCR reaches zero and the last data has been transferred to memory.

It is reset by writing a non zero value in PERIPH_RCR or PERIPH_RNCR.

22.3.5.2 Transmit Transfer End

This flag is set when PERIPH_TCR reaches zero and the last data has been written into peripheral THR.

It is reset by writing a non zero value in PERIPH_TCR or PERIPH_TNCR.

22.3.5.3 Receive Buffer Full

This flag is set when PERIPH_RCR reaches zero with PERIPH_RNCR also set to zero and the last data has been transferred to memory.

It is reset by writing a non zero value in PERIPH_TCR or PERIPH_TNCR.

22.3.5.4 Transmit Buffer Empty

This flag is set when PERIPH_TCR reaches zero with PERIPH_TNCR also set to zero and the last data has been written into peripheral THR.

It is reset by writing a non zero value in PERIPH_TCR or PERIPH_TNCR.

22.4 Peripheral DMA Controller (PDC) User Interface

Table 22-1. Register Mapping

| Offset | Register | Name ⁽¹⁾ | Access | Reset |
|--------|--------------------------------|---------------------|------------|-------|
| 0x100 | Receive Pointer Register | PERIPH_RPR | Read/Write | 0 |
| 0x104 | Receive Counter Register | PERIPH_RCR | Read/Write | 0 |
| 0x108 | Transmit Pointer Register | PERIPH_TPR | Read/Write | 0 |
| 0x10C | Transmit Counter Register | PERIPH_TCR | Read/Write | 0 |
| 0x110 | Receive Next Pointer Register | PERIPH_RNPR | Read/Write | 0 |
| 0x114 | Receive Next Counter Register | PERIPH_RNCR | Read/Write | 0 |
| 0x118 | Transmit Next Pointer Register | PERIPH_TNPR | Read/Write | 0 |
| 0x11C | Transmit Next Counter Register | PERIPH_TNCR | Read/Write | 0 |
| 0x120 | Transfer Control Register | PERIPH_PTCR | Write-only | – |
| 0x124 | Transfer Status Register | PERIPH_PTSR | Read-only | 0 |

Note: 1. PERIPH: Ten registers are mapped in the peripheral memory space at the same offset. These can be defined by the user according to the function and the peripheral desired (DBGU, USART, SSC, SPI, MCI, etc.)

22.4.1 Receive Pointer Register

Name: PERIPH_RPR

Access: Read/Write

| | | | | | | | |
|-------|----|----|----|----|----|----|----|
| 31 | 30 | 29 | 28 | 27 | 26 | 25 | 24 |
| RXPTR | | | | | | | |
| 23 | 22 | 21 | 20 | 19 | 18 | 17 | 16 |
| RXPTR | | | | | | | |
| 15 | 14 | 13 | 12 | 11 | 10 | 9 | 8 |
| RXPTR | | | | | | | |
| 7 | 6 | 5 | 4 | 3 | 2 | 1 | 0 |
| RXPTR | | | | | | | |

- **RXPTR: Receive Pointer Register**

RXPTR must be set to receive buffer address.

When a half duplex peripheral is connected to the PDC, RXPTR = TXPTR.

22.4.2 Receive Counter Register

Name: PERIPH_RCR

Access: Read/Write

| | | | | | | | |
|-------|----|----|----|----|----|----|----|
| 31 | 30 | 29 | 28 | 27 | 26 | 25 | 24 |
| – | – | – | – | – | – | – | – |
| 23 | 22 | 21 | 20 | 19 | 18 | 17 | 16 |
| – | – | – | – | – | – | – | – |
| 15 | 14 | 13 | 12 | 11 | 10 | 9 | 8 |
| RXCTR | | | | | | | |
| 7 | 6 | 5 | 4 | 3 | 2 | 1 | 0 |
| RXCTR | | | | | | | |

- **RXCTR: Receive Counter Register**

RXCTR must be set to receive buffer size.

When a half duplex peripheral is connected to the PDC, RXCTR = TXCTR.

0: Stops peripheral data transfer to the receiver

1–65535 = Starts peripheral data transfer if corresponding channel is active

22.4.3 Transmit Pointer Register

Name: PERIPH_TPR

Access: Read/Write

| | | | | | | | |
|-------|----|----|----|----|----|----|----|
| 31 | 30 | 29 | 28 | 27 | 26 | 25 | 24 |
| TXPTR | | | | | | | |
| 23 | 22 | 21 | 20 | 19 | 18 | 17 | 16 |
| TXPTR | | | | | | | |
| 15 | 14 | 13 | 12 | 11 | 10 | 9 | 8 |
| TXPTR | | | | | | | |
| 7 | 6 | 5 | 4 | 3 | 2 | 1 | 0 |
| TXPTR | | | | | | | |

- **TXPTR: Transmit Counter Register**

TXPTR must be set to transmit buffer address.

When a half duplex peripheral is connected to the PDC, RXPTR = TXPTR.

22.4.4 Transmit Counter Register

Name: PERIPH_TCR

Access: Read/Write

| | | | | | | | |
|-------|----|----|----|----|----|----|----|
| 31 | 30 | 29 | 28 | 27 | 26 | 25 | 24 |
| – | – | – | – | – | – | – | – |
| 23 | 22 | 21 | 20 | 19 | 18 | 17 | 16 |
| – | – | – | – | – | – | – | – |
| 15 | 14 | 13 | 12 | 11 | 10 | 9 | 8 |
| TXCTR | | | | | | | |
| 7 | 6 | 5 | 4 | 3 | 2 | 1 | 0 |
| TXCTR | | | | | | | |

- **TXCTR: Transmit Counter Register**

TXCTR must be set to transmit buffer size.

When a half duplex peripheral is connected to the PDC, RXCTR = TXCTR.

0: Stops peripheral data transfer to the transmitter

1- 65535 = Starts peripheral data transfer if corresponding channel is active

22.4.5 Receive Next Pointer Register

Name: PERIPH_RNPR

Access: Read/Write

| | | | | | | | |
|--------|----|----|----|----|----|----|----|
| 31 | 30 | 29 | 28 | 27 | 26 | 25 | 24 |
| RXNPTR | | | | | | | |
| 23 | 22 | 21 | 20 | 19 | 18 | 17 | 16 |
| RXNPTR | | | | | | | |
| 15 | 14 | 13 | 12 | 11 | 10 | 9 | 8 |
| RXNPTR | | | | | | | |
| 7 | 6 | 5 | 4 | 3 | 2 | 1 | 0 |
| RXNPTR | | | | | | | |

- **RXNPTR: Receive Next Pointer**

RXNPTR contains next receive buffer address.

When a half duplex peripheral is connected to the PDC, RXNPTR = TXNPTR.

22.4.6 Receive Next Counter Register

Name: PERIPH_RNCR

Access: Read/Write

| | | | | | | | |
|--------|----|----|----|----|----|----|----|
| 31 | 30 | 29 | 28 | 27 | 26 | 25 | 24 |
| – | – | – | – | – | – | – | – |
| 23 | 22 | 21 | 20 | 19 | 18 | 17 | 16 |
| – | – | – | – | – | – | – | – |
| 15 | 14 | 13 | 12 | 11 | 10 | 9 | 8 |
| RXNCTR | | | | | | | |
| 7 | 6 | 5 | 4 | 3 | 2 | 1 | 0 |
| RXNCTR | | | | | | | |

- **RXNCTR: Receive Next Counter**

RXNCTR contains next receive buffer size.

When a half duplex peripheral is connected to the PDC, RXNCTR = TXNCTR.

22.4.7 Transmit Next Pointer Register

Name: PERIPH_TNPR

Access: Read/Write

| | | | | | | | |
|--------|----|----|----|----|----|----|----|
| 31 | 30 | 29 | 28 | 27 | 26 | 25 | 24 |
| TXNPTR | | | | | | | |
| 23 | 22 | 21 | 20 | 19 | 18 | 17 | 16 |
| TXNPTR | | | | | | | |
| 15 | 14 | 13 | 12 | 11 | 10 | 9 | 8 |
| TXNPTR | | | | | | | |
| 7 | 6 | 5 | 4 | 3 | 2 | 1 | 0 |
| TXNPTR | | | | | | | |

- **TXNPTR: Transmit Next Pointer**

TXNPTR contains next transmit buffer address.

When a half duplex peripheral is connected to the PDC, RXNPTR = TXNPTR.

22.4.8 Transmit Next Counter Register

Name: PERIPH_TNCR

Access: Read/Write

| | | | | | | | |
|--------|----|----|----|----|----|----|----|
| 31 | 30 | 29 | 28 | 27 | 26 | 25 | 24 |
| – | – | – | – | – | – | – | – |
| 23 | 22 | 21 | 20 | 19 | 18 | 17 | 16 |
| – | – | – | – | – | – | – | – |
| 15 | 14 | 13 | 12 | 11 | 10 | 9 | 8 |
| TXNCTR | | | | | | | |
| 7 | 6 | 5 | 4 | 3 | 2 | 1 | 0 |
| TXNCTR | | | | | | | |

- **TXNCTR: Transmit Counter Next**

TXNCTR contains next transmit buffer size.

When a half duplex peripheral is connected to the PDC, RXNCTR = TXNCTR.

22.4.9 Transfer Control Register

Name: PERIPH_PTCR

Access: Write-only

| | | | | | | | |
|----|----|----|----|----|----|--------|-------|
| 31 | 30 | 29 | 28 | 27 | 26 | 25 | 24 |
| – | – | – | – | – | – | – | – |
| 23 | 22 | 21 | 20 | 19 | 18 | 17 | 16 |
| – | – | – | – | – | – | – | – |
| 15 | 14 | 13 | 12 | 11 | 10 | 9 | 8 |
| – | – | – | – | – | – | TXTDIS | TXTEN |
| 7 | 6 | 5 | 4 | 3 | 2 | 1 | 0 |
| – | – | – | – | – | – | RXTDIS | RXTEN |

- **RXTEN: Receiver Transfer Enable**

0: No effect.

1: Enables PDC receiver channel requests if RXTDIS is not set.

When a half duplex peripheral is connected to the PDC, enabling the receiver channel requests automatically disables the transmitter channel requests. It is forbidden to set both TXTEN and RXTEN for a half duplex peripheral.

- **RXTDIS: Receiver Transfer Disable**

0: No effect.

1: Disables the PDC receiver channel requests.

When a half duplex peripheral is connected to the PDC, disabling the receiver channel requests also disables the transmitter channel requests.

- **TXTEN: Transmitter Transfer Enable**

0: No effect.

1: Enables the PDC transmitter channel requests.

When a half duplex peripheral is connected to the PDC, it enables the transmitter channel requests only if RXTEN is not set. It is forbidden to set both TXTEN and RXTEN for a half duplex peripheral.

- **TXTDIS: Transmitter Transfer Disable**

0: No effect.

1: Disables the PDC transmitter channel requests.

When a half duplex peripheral is connected to the PDC, disabling the transmitter channel requests disables the receiver channel requests.

22.4.10 Transfer Status Register

Name: PERIPH_PTSR

Access: Read-only

| | | | | | | | |
|----|----|----|----|----|----|----|-------|
| 31 | 30 | 29 | 28 | 27 | 26 | 25 | 24 |
| – | – | – | – | – | – | – | – |
| 23 | 22 | 21 | 20 | 19 | 18 | 17 | 16 |
| – | – | – | – | – | – | – | – |
| 15 | 14 | 13 | 12 | 11 | 10 | 9 | 8 |
| – | – | – | – | – | – | – | TXTEN |
| 7 | 6 | 5 | 4 | 3 | 2 | 1 | 0 |
| – | – | – | – | – | – | – | RXTEN |

- **RXTEN: Receiver Transfer Enable**

0: PDC Receiver channel requests are disabled.

1: PDC Receiver channel requests are enabled.

- **TXTEN: Transmitter Transfer Enable**

0: PDC Transmitter channel requests are disabled.

1: PDC Transmitter channel requests are enabled.

23. Clock Generator (CKGR)

23.1 Overview

The Clock Generator is made up of 2 PLL, a Main Oscillator, and a 32.768 kHz low-power Oscillator.

It provides the following clocks:

- SLCK, the Slow Clock, which is the only permanent clock within the system
- MAINCK is the output of the Main Oscillator

The Clock Generator User Interface is embedded within the Power Management Controller one and is described in [Section 24.9](#). However, the Clock Generator registers are named CKGR_.

- PLLACK is the output of the Divider and PLL A block
- PLLBCK is the output of the Divider and PLL B block

23.2 Slow Clock Crystal Oscillator

The Clock Generator integrates a 32.768 kHz low-power oscillator. The XIN32 and XOUT32 pins must be connected to a 32.768 kHz crystal. Two external capacitors must be wired as shown in [Figure 23-1](#).

Figure 23-1. Typical Slow Clock Crystal Oscillator Connection

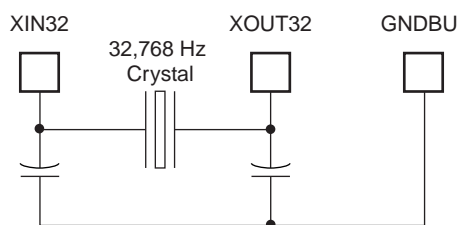

23.3 Main Oscillator

[Figure 23-2](#) shows the Main Oscillator block diagram.

Figure 23-2. Main Oscillator Block Diagram

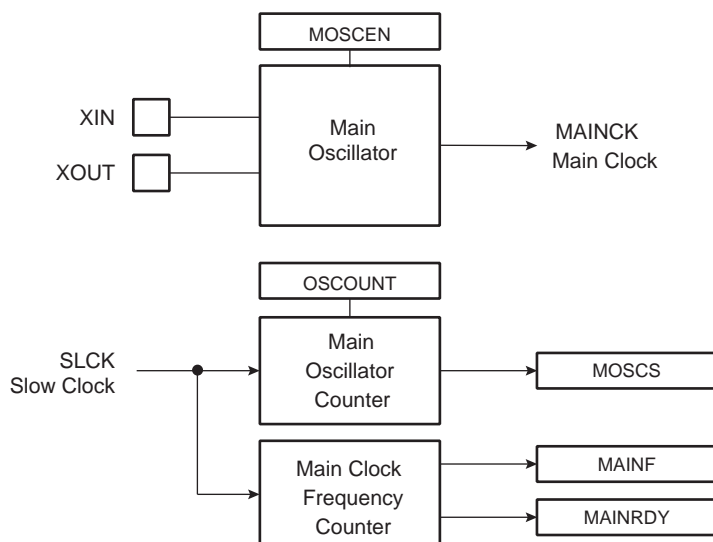

23.3.1 Main Oscillator Connections

The Clock Generator integrates a Main Oscillator that is designed for a 3 to 20 MHz fundamental crystal. The typical crystal connection is illustrated in Figure 23-3. The 1 k Ω resistor is only required for crystals with frequencies lower than 8 MHz. For further details on the electrical characteristics of the Main Oscillator, see the section “DC Characteristics” of the product datasheet.

Figure 23-3. Typical Crystal Connection

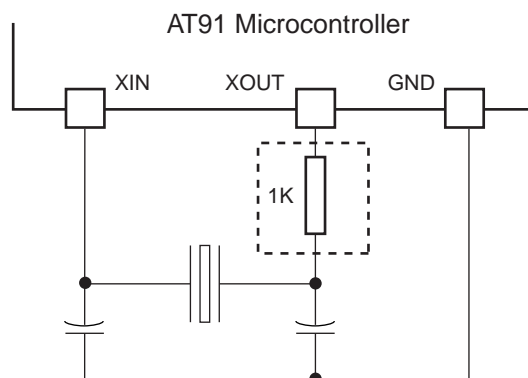

23.3.2 Main Oscillator Startup Time

The startup time of the Main Oscillator is given in the DC Characteristics section of the product datasheet. The startup time depends on the crystal frequency and decreases when the frequency rises.

23.3.3 Main Oscillator Control

To minimize the power required to start up the system, the main oscillator is disabled after reset and slow clock is selected.

The software enables or disables the main oscillator so as to reduce power consumption by clearing the MOSCEN bit in the Main Oscillator Register (CKGR_MOR).

When disabling the main oscillator by clearing the MOSCEN bit in CKGR_MOR, the MOSCS bit in PMC_SR is automatically cleared, indicating the main clock is off.

When enabling the main oscillator, the user must initiate the main oscillator counter with a value corresponding to the startup time of the oscillator. This startup time depends on the crystal frequency connected to the main oscillator.

When the MOSCEN bit and the OSCOUNT are written in CKGR_MOR to enable the main oscillator, the MOSCS bit in PMC_SR (Status Register) is cleared and the counter starts counting down on the slow clock divided by 8 from the OSCOUNT value. Since the OSCOUNT value is coded with 8 bits, the maximum startup time is about 62 ms.

When the counter reaches 0, the MOSCS bit is set, indicating that the main clock is valid. Setting the MOSCS bit in PMC_IMR can trigger an interrupt to the processor.

23.3.4 Main Clock Frequency Counter

The Main Oscillator features a Main Clock frequency counter that provides the quartz frequency connected to the Main Oscillator. Generally, this value is known by the system designer; however, it is useful for the boot program to configure the device with the correct clock speed, independently of the application.

The Main Clock frequency counter starts incrementing at the Main Clock speed after the next rising edge of the Slow Clock as soon as the Main Oscillator is stable, i.e., as soon as the MOSCS bit is set. Then, at the 16th falling edge of Slow Clock, the MAINRDY bit in CKGR_MCFR (Main Clock Frequency Register) is set and the counter

stops counting. Its value can be read in the MAINF field of CKGR_MCFR and gives the number of Main Clock cycles during 16 periods of Slow Clock, so that the frequency of the crystal connected on the Main Oscillator can be determined.

23.3.5 Main Oscillator Bypass

The user can input a clock on the device instead of connecting a crystal. In this case, the user has to provide the external clock signal on the XIN pin. The input characteristics of the XIN pin under these conditions are given in the product electrical characteristics section. The programmer has to be sure to set the OSCBYPASS bit to 1 and the MOSCEN bit to 0 in the Main OSC register (CKGR_MOR) for the external clock to operate properly.

23.4 Divider and PLL Block

The PLL embeds an input divider to increase the accuracy of the resulting clock signals. However, the user must respect the PLL minimum input frequency when programming the divider.

Figure 23-4 shows the block diagram of the divider and PLL blocks.

Figure 23-4. Divider and PLL Block Diagram

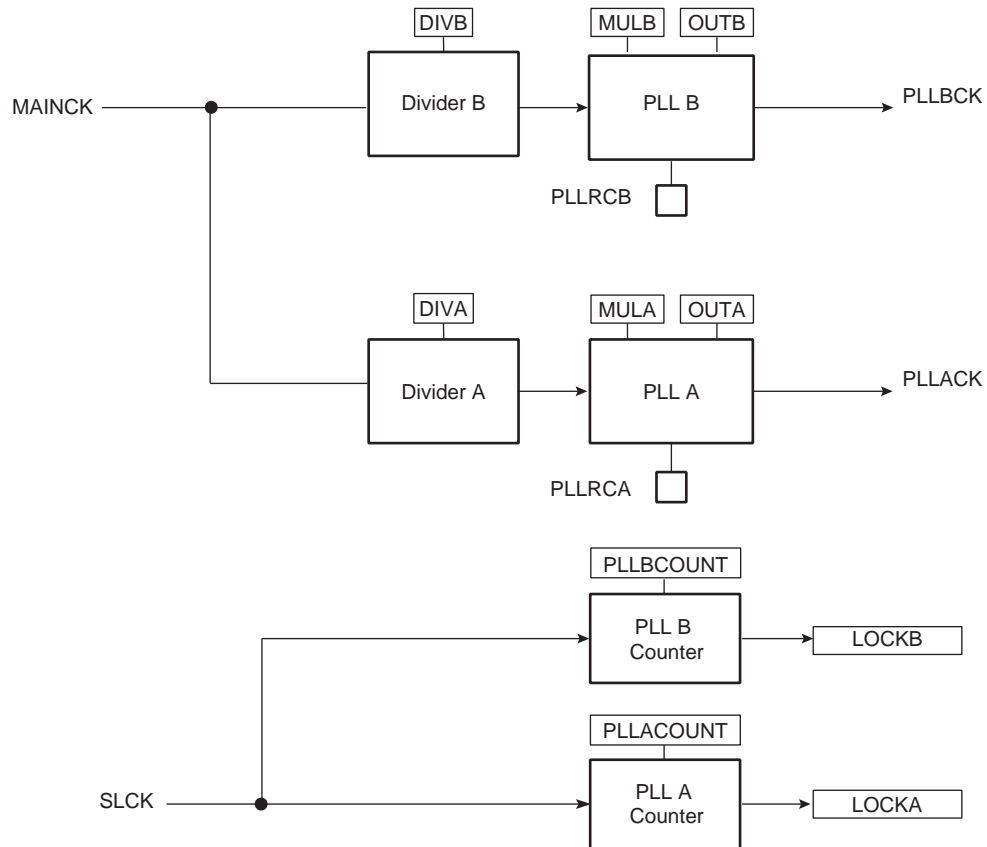

23.4.1 PLL Filter

The PLL requires connection to an external second-order filter through the PLLRCA and/or PLLRCB pin. [Figure 23-5](#) shows a schematic of these filters.

Figure 23-5. PLL Capacitors and Resistors

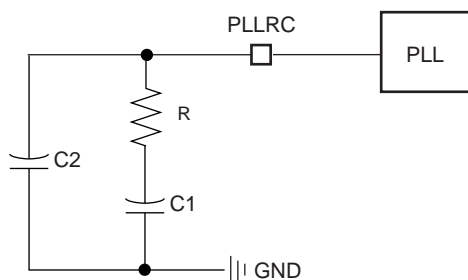

Values of R, C1 and C2 to be connected to the PLLRC pin must be calculated as a function of the PLL input frequency, the PLL output frequency and the phase margin. A trade-off has to be found between output signal overshoot and startup time.

23.4.2 Divider and Phase Lock Loop Programming

The divider can be set between 1 and 255 in steps of 1. When a divider field (DIV) is set to 0, the output of the corresponding divider and the PLL output is a continuous signal at level 0. On reset, each DIV field is set to 0, thus the corresponding PLL input clock is set to 0.

The PLL allows multiplication of the divider's outputs. The PLL clock signal has a frequency that depends on the respective source signal frequency and on the parameters DIV and MUL. The factor applied to the source signal frequency is $(MUL + 1)/DIV$. When MUL is written to 0, the corresponding PLL is disabled and its power consumption is saved. Re-enabling the PLL can be performed by writing a value higher than 0 in the MUL field.

Whenever the PLL is re-enabled or one of its parameters is changed, the LOCK bit (LOCKA or LOCKB) in PMC_SR is automatically cleared. The values written in the PLLCOUNT field (PLLACOUNT or PLLBCOUNT) in CKGR_PLLR (CKGR_PLLAR or CKGR_PLLBR), are loaded in the PLL counter. The PLL counter then decrements at the speed of the Slow Clock until it reaches 0. At this time, the LOCK bit is set in PMC_SR and can trigger an interrupt to the processor. The user has to load the number of Slow Clock cycles required to cover the PLL transient time into the PLLCOUNT field. The transient time depends on the PLL filter. The initial state of the PLL and its target frequency can be calculated using a specific tool provided by Atmel.

During the PLLA or PLLB initialization, the PMC_PLLICPR must be programmed correctly.

24. Power Management Controller (PMC)

24.1 Overview

The Power Management Controller (PMC) optimizes power consumption by controlling all system and user peripheral clocks. The PMC enables/disables the clock inputs to many of the peripherals and the ARM Processor.

The Power Management Controller provides the following clocks:

- MCK, the Master Clock, programmable from a few hundred Hz to the maximum operating frequency of the device. It is available to the modules running permanently, such as the AIC and the Memory Controller.
- Processor Clock (PCK), must be switched off when entering processor in Idle Mode.
- Peripheral Clocks, typically MCK, provided to the embedded peripherals (USART, SSC, SPI, TWI, TC, MCI, etc.) and independently controllable. In order to reduce the number of clock names in a product, the Peripheral Clocks are named MCK in the product datasheet.
- UDP Clock (UDPCK), required by USB Device Port operations.
- Programmable Clock Outputs can be selected from the clocks provided by the clock generator and driven on the PCKx pins.

24.2 Master Clock Controller

The Master Clock Controller provides selection and division of the Master Clock (MCK). MCK is the clock provided to all the peripherals and the memory controller.

The Master Clock is selected from one of the clocks provided by the Clock Generator. Selecting the Slow Clock provides a Slow Clock signal to the whole device. Selecting the Main Clock saves power consumption of the PLLs.

The Master Clock Controller is made up of a clock selector and a prescaler. It also contains a Master Clock divider which allows the processor clock to be faster than the Master Clock.

The Master Clock selection is made by writing the CSS field (Clock Source Selection) in PMC_MCKR (Master Clock Register). The prescaler supports the division by a power of 2 of the selected clock between 1 and 64. The PRES field in PMC_MCKR programs the prescaler. The Master Clock divider can be programmed through the MDIV field in PMC_MCKR.

Each time PMC_MCKR is written to define a new Master Clock, the MCKRDY bit is cleared in PMC_SR. It reads 0 until the Master Clock is established. Then, the MCKRDY bit is set and can trigger an interrupt to the processor. This feature is useful when switching from a high-speed clock to a lower one to inform the software when the change is actually done.

Figure 24-1. Master Clock Controller

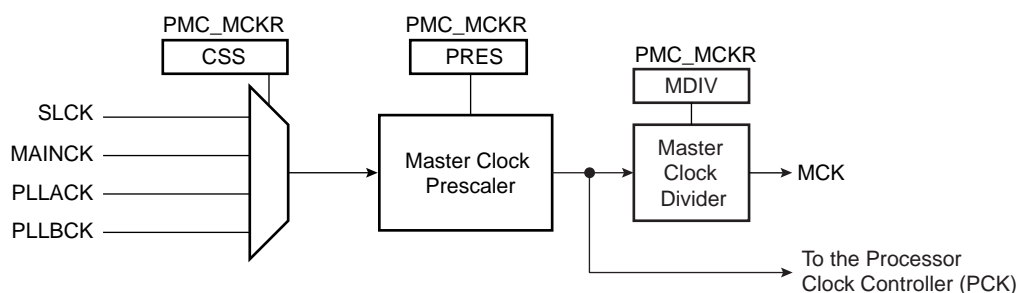

24.3 Processor Clock Controller

The PMC features a Processor Clock Controller (PCK) that implements the Processor Idle Mode. The Processor Clock can be disabled by writing the System Clock Disable Register (PMC_SCDR). The status of this clock (at least for debug purposes) can be read in the System Clock Status Register (PMC_SCSR).

The Processor Clock PCK is enabled after a reset and is automatically re-enabled by any enabled interrupt. The Processor Idle Mode is achieved by disabling the Processor Clock and entering Wait for Interrupt Mode. The Processor Clock is automatically re-enabled by any enabled fast or normal interrupt, or by the reset of the product.

Note: The ARM Wait for Interrupt mode is entered with CP15 coprocessor operation. Refer to the Atmel application note *Optimizing Power Consumption of AT91SAM9261-based Systems*, literature number 6217.

When the Processor Clock is disabled, the current instruction is finished before the clock is stopped, but this does not prevent data transfers from other masters of the system bus.

24.4 USB Clock Controller

The USB Source Clock is always generated from the PLL B output. If using the USB, the user must program the PLL to generate a 48 MHz, a 96 MHz or a 192 MHz signal with an accuracy of $\pm 0.25\%$ depending on the USBDIV bit in CKGR_PLLBR (see [Figure 24-2](#)).

When the PLL B output is stable, i.e., the LOCKB is set:

- The USB device clock can be enabled by setting the UDP bit in PMC_SCER. To save power on this peripheral when it is not used, the user can set the UDP bit in PMC_SCDR. The UDP bit in PMC_SCSR gives the activity of this clock. The USB device port require both the 48 MHz signal and the Master Clock. The Master Clock may be controlled via the Master Clock Controller.

Figure 24-2. USB Clock Controller

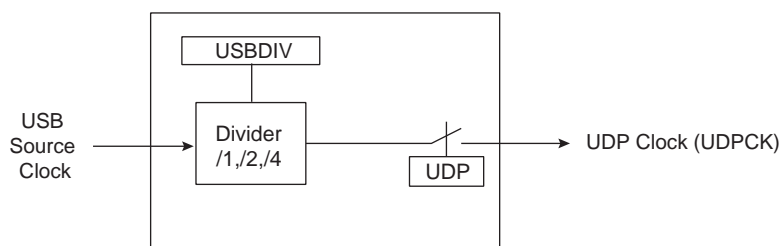

24.5 Peripheral Clock Controller

The Power Management Controller controls the clocks of each embedded peripheral by the way of the Peripheral Clock Controller. The user can individually enable and disable the Master Clock on the peripherals by writing into the Peripheral Clock Enable (PMC_PCER) and Peripheral Clock Disable (PMC_PCDR) registers. The status of the peripheral clock activity can be read in the Peripheral Clock Status Register (PMC_PCSR).

When a peripheral clock is disabled, the clock is immediately stopped. The peripheral clocks are automatically disabled after a reset.

In order to stop a peripheral, it is recommended that the system software wait until the peripheral has executed its last programmed operation before disabling the clock. This is to avoid data corruption or erroneous behavior of the system.

The bit number within the Peripheral Clock Control registers (PMC_PCER, PMC_PCDR, and PMC_PCSR) is the Peripheral Identifier defined at the product level. Generally, the bit number corresponds to the interrupt source number assigned to the peripheral.

24.6 Programmable Clock Output Controller

The PMC controls 4 signals to be output on external pins PCKx. Each signal can be independently programmed via the PMC_PCKx registers.

PCKx can be independently selected between the Slow clock, the PLL A output, the PLL B output and the main clock by writing the CSS field in PMC_PCKx. Each output signal can also be divided by a power of 2 between 1 and 64 by writing the PRES (Prescaler) field in PMC_PCKx.

Each output signal can be enabled and disabled by writing 1 in the corresponding bit, PCKx of PMC_SCER and PMC_SCDR, respectively. Status of the active programmable output clocks are given in the PCKx bits of PMC_SCSR (System Clock Status Register).

Moreover, like the PCK, a status bit in PMC_SR indicates that the Programmable Clock is actually what has been programmed in the Programmable Clock registers.

As the Programmable Clock Controller does not manage with glitch prevention when switching clocks, it is strongly recommended to disable the Programmable Clock before any configuration change and to re-enable it after the change is actually performed.

24.7 Programming Sequence

1. Enabling the Main Oscillator:

The main oscillator is enabled by setting the MOSCEN field in the CKGR_MOR. In some cases it may be advantageous to define a startup time. This can be achieved by writing a value in the OSCOUNT field in the CKGR_MOR.

Once this register has been correctly configured, the user must wait for MOSCS field in the PMC_SR to be set. This can be done either by polling the status register or by waiting the interrupt line to be raised if the associated interrupt to MOSCS has been enabled in the PMC_IER.

Code Example:

```
write_register(CKGR_MOR, 0x00000701)
```

Start Up Time = $8 * OSCOUNT / SLCK = 56$ Slow Clock Cycles.

So, the main oscillator will be enabled (MOSCS bit set) after 56 Slow Clock Cycles.

2. Checking the Main Oscillator Frequency (Optional):

In some situations the user may need an accurate measure of the main oscillator frequency. This measure can be accomplished via the CKGR_MCFR.

Once the MAINRDY field is set in CKGR_MCFR, the user may read the MAINF field in CKGR_MCFR. This provides the number of main clock cycles within sixteen slow clock cycles.

3. Setting PLL A and divider A:

All parameters necessary to configure PLL A and divider A are located in the CKGR_PLLAR. ICPPLLA in PMC_PLLICPR must be set to 1 before configuring the CKGR_PLLAR.

It is important to note that Bit 29 must always be set to 1 when programming the CKGR_PLLAR.

The DIVA field is used to control the divider A itself. The user can program a value between 0 and 255.

Divider A output is divider A input divided by DIVA. By default, DIVA parameter is set to 0 which means that divider A is turned off.

The OUTA field is used to select the PLL A output frequency range.

The MULA field is the PLL A multiplier factor. This parameter can be programmed between 0 and 2047. If MULA is set to 0, PLL A will be turned off. Otherwise PLL A output frequency is PLL A input frequency multiplied by (MULA + 1).

The PLLACOUNT field specifies the number of slow clock cycles before LOCKA bit is set in the PMC_SR after CKGR_PLLAR has been written.

Once CKGR_PLLAR has been written, the user is obliged to wait for the LOCKA bit to be set in the PMC_SR. This can be done either by polling the status register or by waiting the interrupt line to be raised if the associated interrupt to LOCKA has been enabled in the PMC_IER.

All parameters in CKGR_PLLAR can be programmed in a single write operation. If at some stage one of the following parameters, SRCA, MULA, DIVA is modified, LOCKA bit will go low to indicate that PLL A is not ready yet. When PLL A is locked, LOCKA will be set again. User has to wait for LOCKA bit to be set before using the PLL A output clock.

Code Example:

```
write_register(CKGR_PLLAR, 0x20030605)
```

PLL A and divider A are enabled. PLL A input clock is main clock divided by 5. PLL A output clock is PLL A input clock multiplied by 4. Once CKGR_PLLAR has been written, LOCKA bit will be set after six slow clock cycles.

4. Setting PLL B and divider B:

All parameters needed to configure PLL B and divider B are located in the CKGR_PLLBR. ICPPLLBR in PMC_PLLICPR must be set to 1 before configuring the CKGR_PLLBR.

The DIVB field is used to control divider B itself. A value between 0 and 255 can be programmed. Divider B output is divider B input divided by DIVB parameter. By default DIVB parameter is set to 0 which means that divider B is turned off.

The OUTB field is used to select the PLL B output frequency range.

The MULB field is the PLL B multiplier factor. This parameter can be programmed between 0 and 2047. If MULB is set to 0, PLL B will be turned off, otherwise the PLL B output frequency is PLL B input frequency multiplied by (MULB + 1).

The PLLBCOUNT field specifies the number of slow clock cycles before LOCKB bit is set in the PMC_SR after CKGR_PLLBR has been written.

Once the PMC_PLLB register has been written, the user must wait for the LOCKB bit to be set in the PMC_SR. This can be done either by polling the status register or by waiting the interrupt line to be raised if the associated interrupt to LOCKB has been enabled in the PMC_IER. All parameters in CKGR_PLLBR can be programmed in a single write operation. If at some stage one of the following parameters, MULB, DIVB is modified, LOCKB bit will go low to indicate that PLL B is not ready yet. When PLL B is locked, LOCKB will be set again. The user is constrained to wait for LOCKB bit to be set before using the PLL A output clock.

The USBDIV field is used to control the additional divider by 1, 2 or 4, which generates the USB clock(s).

Code Example:

```
write_register(CKGR_PLLBR, 0x00040805)
```

If PLL B and divider B are enabled, the PLL B input clock is the main clock. PLL B output clock is PLL B input clock multiplied by 5. Once CKGR_PLLBR has been written, LOCKB bit will be set after eight slow clock cycles.

5. Selection of Master Clock and Processor Clock

The Master Clock and the Processor Clock are configurable via the PMC_MCKR.

The CSS field is used to select the Master Clock divider source. By default, the selected clock source is slow clock.

The PRES field is used to control the Master Clock prescaler. The user can choose between different values (1, 2, 4, 8, 16, 32, 64). Master Clock output is prescaler input divided by PRES parameter. By default, PRES parameter is set to 0 which means that master clock is equal to slow clock.

The MDIV field is used to control the Master Clock divider. It is possible to choose between different values (0, 1, 2). The Master Clock output is Processor Clock divided by 1, 2 or 4, depending on the value programmed in MDIV. By default, MDIV is set to 0, which indicates that the Processor Clock is equal to the Master Clock.

Once the PMC_MCKR has been written, the user must wait for the MCKRDY bit to be set in the PMC_SR. This can be done either by polling the status register or by waiting for the interrupt line to be raised if the associated interrupt to MCKRDY has been enabled in the PMC_IER.

The PMC_MCKR must not be programmed in a single write operation. For each clock switching, the user must take care to:

- change one by one the CSS, MDIV, and PRES fields
- wait till the MCKRDY bit is set in PMC_SR before changing the PMC_MCKR
- ensure that each transitory frequency value is in the operational range for PCK and MCK.

If at some stage one of the following parameters, CSS or PRES, is modified, the MCKRDY bit will go low to indicate that the Master Clock and the Processor Clock are not ready yet. The user must wait for MCKRDY bit to be set again before using the Master and Processor Clocks.

Note: IF PLLx clock was selected as the Master Clock and the user decides to modify it by writing in CKGR_PLLR (CKGR_PLLAR or CKGR_PLLBR), the MCKRDY flag will go low while PLL is unlocked. Once PLL is locked again, LOCK (LOCKA or LOCKB) goes high and MCKRDY is set. While PLLA is unlocked, the Master Clock selection is automatically changed to Slow Clock. While PLLB is unlocked, the Master Clock selection is automatically changed to Main Clock. For further information, see [Section 24.8.2. "Clock Switching Waveforms" on page 242.](#)

Code Example:

```
write_register(PMC_MCKR, 0x00000001)
wait (MCKRDY=1)

write_register(PMC_MCKR, 0x00000011)
wait (MCKRDY=1)
```

The Master Clock is main clock divided by 16.

The Processor Clock is the Master Clock.

6. Selection of Programmable clocks

Programmable clocks are controlled via registers; PMC_SCER, PMC_SCDR and PMC_SCSR.

Programmable clocks can be enabled and/or disabled via the PMC_SCER and PMC_SCDRs. Depending on the system used, 4 Programmable clocks can be enabled or disabled. The PMC_SCSR provides a clear indication as to which Programmable clock is enabled. By default all Programmable clocks are disabled.

PMC_PCKx registers are used to configure Programmable clocks.

The CSS field is used to select the Programmable clock divider source. Four clock options are available: main clock, slow clock, PLLACK, PLLBCK. By default, the clock source selected is slow clock.

The PRES field is used to control the Programmable clock prescaler. It is possible to choose between different values (1, 2, 4, 8, 16, 32, 64). Programmable clock output is prescaler input divided by PRES parameter. By default, the PRES parameter is set to 0 which means that master clock is equal to slow clock.

Once the PMC_PCKx register has been programmed, The corresponding Programmable clock must be enabled and the user is constrained to wait for the PCKRDYx bit to be set in the PMC_SR. This can be done either by polling the status register or by waiting the interrupt line to be raised if the associated interrupt to

PCKRDYx has been enabled in the PMC_IER. All parameters in PMC_PCKx can be programmed in a single write operation.

If the CSS and PRES parameters are to be modified, the corresponding Programmable clock must be disabled first. The parameters can then be modified. Once this has been done, the user must re-enable the Programmable clock and wait for the PCKRDYx bit to be set.

Code Example:

```
write_register(PMC_PCK0, 0x00000015)
```

Programmable clock 0 is main clock divided by 32.

7. Enabling Peripheral Clocks

Once all of the previous steps have been completed, the peripheral clocks can be enabled and/or disabled via registers PMC_PCER and PMC_PCDR.

Depending on the system used, 17 peripheral clocks can be enabled or disabled. The PMC_PCSR provides a clear view as to which peripheral clock is enabled.

Note: Each enabled peripheral clock corresponds to Master Clock.

Code Examples:

```
write_register(PMC_PCER, 0x00000110)
```

Peripheral clocks 4 and 8 are enabled.

```
write_register(PMC_PCDR, 0x00000010)
```

Peripheral clock 4 is disabled.

24.8 Clock Switching Details

24.8.1 Master Clock Switching Timings

Table 24-1 and Table 24-2 give the worst case timings required for the Master Clock to switch from one selected clock to another one. This is in the event that the prescaler is de-activated. When the prescaler is activated, an additional time of 64 clock cycles of the new selected clock has to be added.

Table 24-1. Clock Switching Timings (Worst Case)

| From To | Main Clock | SLCK | PLL Clock |
|------------|---|--|--|
| Main Clock | – | 4 x SLCK + 2.5 x Main Clock | 3 x PLL Clock + 4 x SLCK + 1 x Main Clock |
| SLCK | 0.5 x Main Clock + 4.5 x SLCK | – | 3 x PLL Clock + 5 x SLCK |
| PLL Clock | 0.5 x Main Clock + 4 x SLCK + PLLCOUNT x SLCK + 2.5 x PLLx Clock | 2.5 x PLL Clock + 5 x SLCK + PLLCOUNT x SLCK | 2.5 x PLL Clock + 4 x SLCK + PLLCOUNT x SLCK |

- Notes:
1. PLL designates either the PLL A or the PLL B Clock.
 2. PLLCOUNT designates either PLLACOUNT or PLLBCOUNT.

Table 24-2. Clock Switching Timings Between Two PLLs (Worst Case)

| From To | PLLA Clock | PLL B Clock |
|-------------|--|--|
| PLLA Clock | 2.5 x PLLA Clock + 4 x SLCK + PLLACOUNT x SLCK | 3 x PLLA Clock + 4 x SLCK + 1.5 x PLLA Clock |
| PLL B Clock | 3 x PLLB Clock + 4 x SLCK + 1.5 x PLLB Clock | 2.5 x PLLB Clock + 4 x SLCK + PLLBCOUNT x SLCK |

24.8.2 Clock Switching Waveforms

Figure 24-3. Switch Master Clock from Slow Clock to PLL Clock

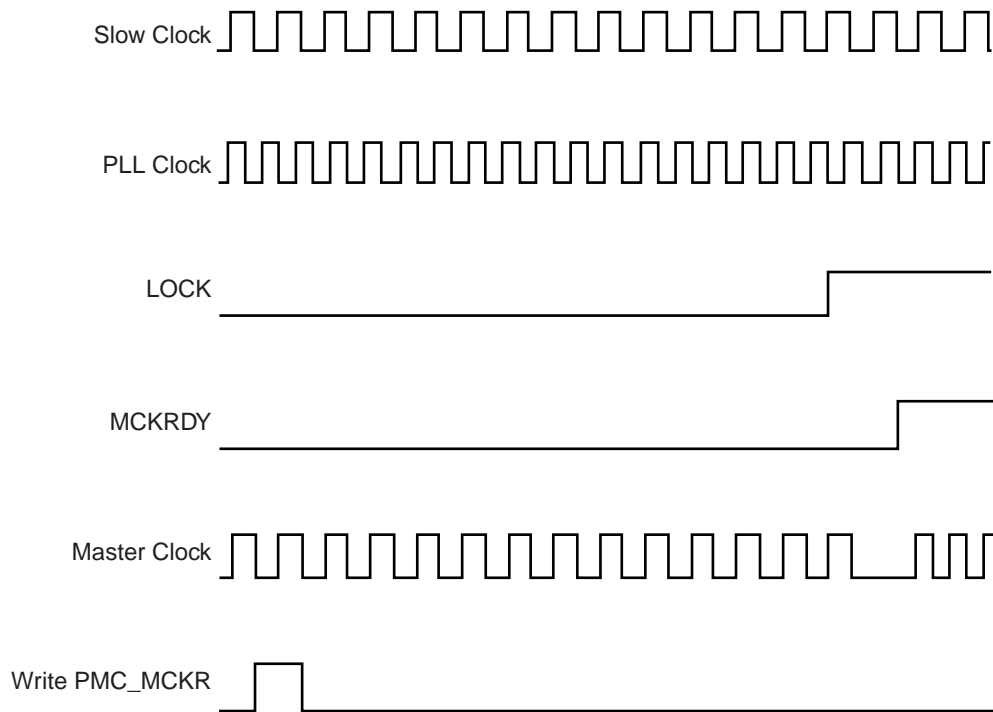

Figure 24-4. Switch Master Clock from Main Clock to Slow Clock

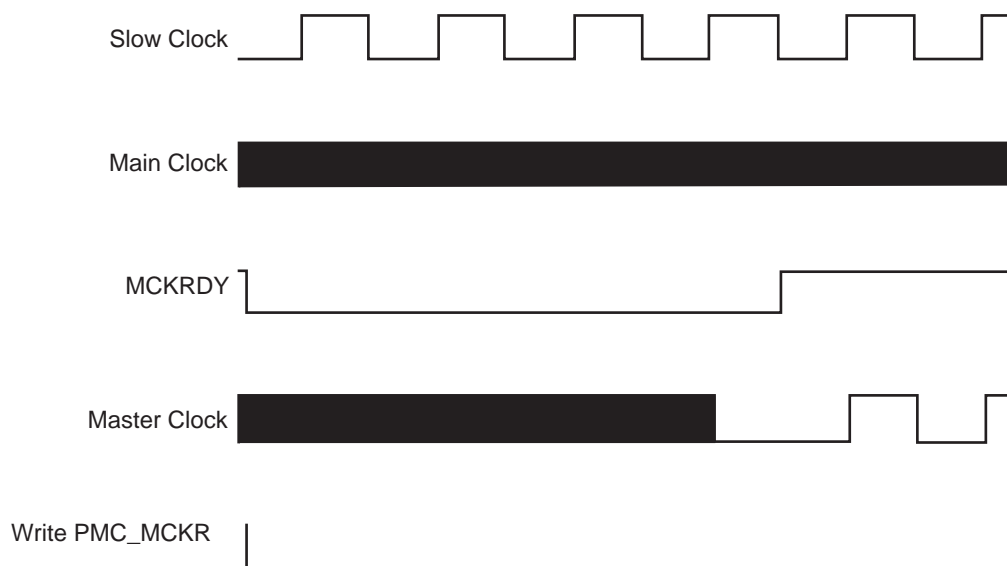

Figure 24-5. Change PLLA Programming

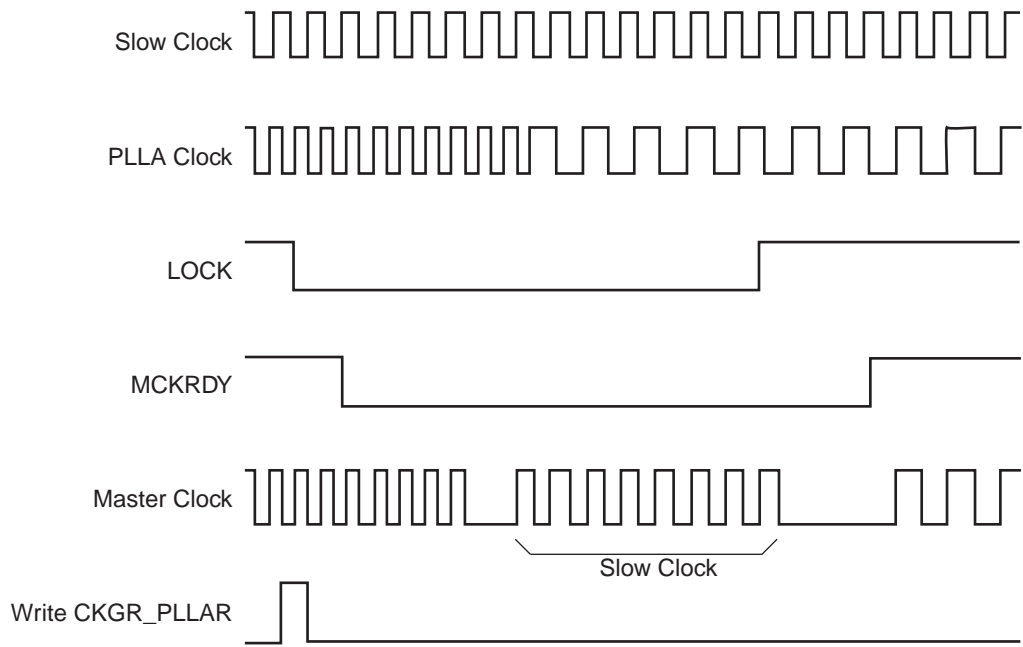

Figure 24-6. Change PLLB Programming

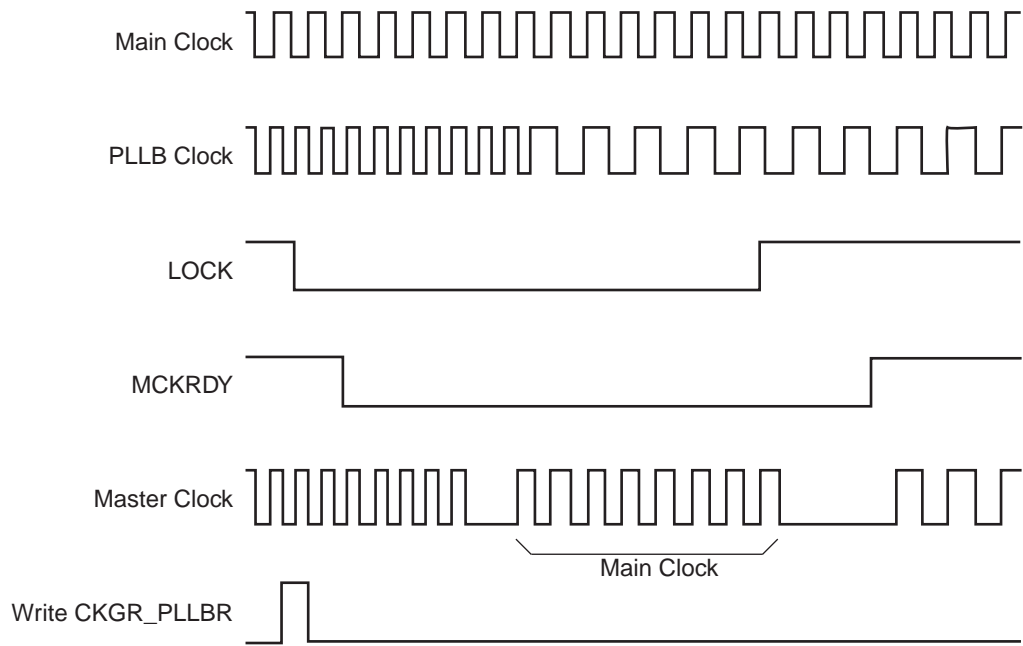
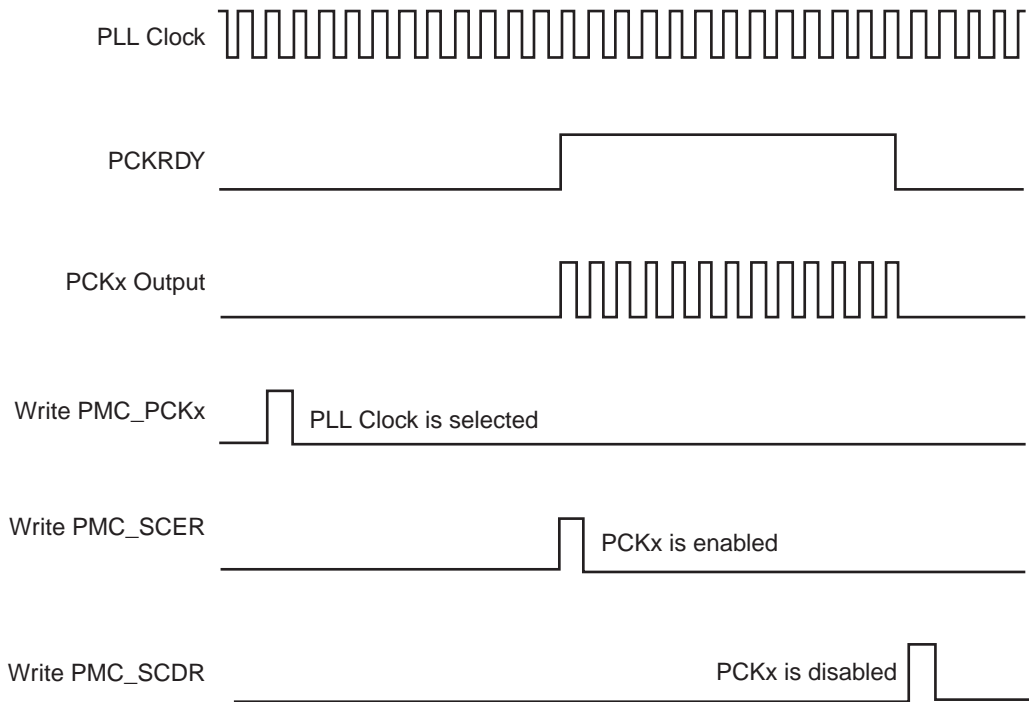

Figure 24-7. Programmable Clock Output Programming



24.9 Power Management Controller (PMC) User Interface

Table 24-3. Register Mapping

| Offset | Register | Name | Access | Reset Value |
|---------------|-----------------------------------|-------------|------------|-------------|
| 0x0000 | System Clock Enable Register | PMC_SCER | Write-only | – |
| 0x0004 | System Clock Disable Register | PMC_SCDR | Write-only | – |
| 0x0008 | System Clock Status Register | PMC_SCSR | Read-only | 0x03 |
| 0x000C | Reserved | – | – | – |
| 0x0010 | Peripheral Clock Enable Register | PMC_PCER | Write-only | – |
| 0x0014 | Peripheral Clock Disable Register | PMC_PCDR | Write-only | – |
| 0x0018 | Peripheral Clock Status Register | PMC_PCSR | Read-only | 0x0 |
| 0x001C | Reserved | – | – | – |
| 0x0020 | Main Oscillator Register | CKGR_MOR | Read/Write | 0x0 |
| 0x0024 | Main Clock Frequency Register | CKGR_MCFR | Read-only | 0x0 |
| 0x0028 | PLL A Register | CKGR_PLLAR | Read/Write | 0x3F00 |
| 0x002C | PLL B Register | CKGR_PLLBR | Read/Write | 0x3F00 |
| 0x0030 | Master Clock Register | PMC_MCKR | Read/Write | 0x0 |
| 0x0038 | Reserved | – | – | – |
| 0x003C | Reserved | – | – | – |
| 0x0040 | Programmable Clock 0 Register | PMC_PCK0 | Read/Write | 0x0 |
| 0x0044 | Programmable Clock 1 Register | PMC_PCK1 | Read/Write | 0x0 |
| ... | ... | ... | ... | ... |
| 0x0060 | Interrupt Enable Register | PMC_IER | Write-only | – |
| 0x0064 | Interrupt Disable Register | PMC_IDR | Write-only | – |
| 0x0068 | Status Register | PMC_SR | Read-only | 0x08 |
| 0x006C | Interrupt Mask Register | PMC_IMR | Read-only | 0x0 |
| 0x0070–0x007C | Reserved | – | – | – |
| 0x0080 | Charge Pump Current Register | PMC_PLLICPR | Read/Write | – |
| 0x0084–0x00FC | Reserved | – | – | – |

24.9.1 PMC System Clock Enable Register

Name: PMC_SCER

Address: 0xFFFFFC00

Access: Write-only

| | | | | | | | |
|-----|-----|----|----|------|------|------|------|
| 31 | 30 | 29 | 28 | 27 | 26 | 25 | 24 |
| – | – | – | – | – | – | – | – |
| 23 | 22 | 21 | 20 | 19 | 18 | 17 | 16 |
| – | – | – | – | – | – | HCK1 | HCK0 |
| 15 | 14 | 13 | 12 | 11 | 10 | 9 | 8 |
| – | – | – | – | PCK3 | PCK2 | PCK1 | PCK0 |
| 7 | 6 | 5 | 4 | 3 | 2 | 1 | 0 |
| UDP | UHP | – | – | – | – | – | – |

- **UDP: USB Device Port Clock Enable**

0: No effect.

1: Enables the 48 MHz clock of the USB Device Port.

- **PCKx: Programmable Clock x Output Enable**

0: No effect.

1: Enables the corresponding Programmable Clock output.

24.9.2 PMC System Clock Disable Register

Name: PMC_SCDR

Address: 0xFFFFFC04

Access: Write-only

| | | | | | | | |
|-----|-----|----|----|------|------|------|------|
| 31 | 30 | 29 | 28 | 27 | 26 | 25 | 24 |
| – | – | – | – | – | – | – | – |
| 23 | 22 | 21 | 20 | 19 | 18 | 17 | 16 |
| – | – | – | – | – | – | HCK1 | HCK0 |
| 15 | 14 | 13 | 12 | 11 | 10 | 9 | 8 |
| – | – | – | – | PCK3 | PCK2 | PCK1 | PCK0 |
| 7 | 6 | 5 | 4 | 3 | 2 | 1 | 0 |
| UDP | UHP | – | – | – | – | – | PCK |

- **PCK: Processor Clock Disable**

0: No effect.

1: Disables the Processor clock. This is used to enter the processor in Idle Mode.

- **UDP: USB Device Port Clock Disable**

0: No effect.

1: Disables the 48 MHz clock of the USB Device Port.

- **PCKx: Programmable Clock x Output Disable**

0: No effect.

1: Disables the corresponding Programmable Clock output.

24.9.3 PMC System Clock Status Register

Name: PMC_SCSR

Address: 0xFFFFFC08

Access: Read-only

| | | | | | | | |
|-----|-----|----|----|------|------|------|------|
| 31 | 30 | 29 | 28 | 27 | 26 | 25 | 24 |
| – | – | – | – | – | – | – | – |
| 23 | 22 | 21 | 20 | 19 | 18 | 17 | 16 |
| – | – | – | – | – | – | HCK1 | HCK0 |
| 15 | 14 | 13 | 12 | 11 | 10 | 9 | 8 |
| – | – | – | – | PCK3 | PCK2 | PCK1 | PCK0 |
| 7 | 6 | 5 | 4 | 3 | 2 | 1 | 0 |
| UDP | UHP | – | – | – | – | – | PCK |

- **PCK: Processor Clock Status**

0: The Processor clock is disabled.

1: The Processor clock is enabled.

- **UDP: USB Device Port Clock Status**

0: The 48 MHz clock (UDPCK) of the USB Device Port is disabled.

1: The 48 MHz clock (UDPCK) of the USB Device Port is enabled.

- **PCKx: Programmable Clock x Output Status**

0: The corresponding Programmable Clock output is disabled.

1: The corresponding Programmable Clock output is enabled.

24.9.4 PMC Peripheral Clock Enable Register

Name: PMC_PCER
Address: 0xFFFFFC10
Access: Write-only

| | | | | | | | |
|-------|-------|-------|-------|-------|-------|-------|-------|
| 31 | 30 | 29 | 28 | 27 | 26 | 25 | 24 |
| PID31 | PID30 | PID29 | PID28 | PID27 | PID26 | PID25 | PID24 |
| 23 | 22 | 21 | 20 | 19 | 18 | 17 | 16 |
| PID23 | PID22 | PID21 | PID20 | PID19 | PID18 | PID17 | PID16 |
| 15 | 14 | 13 | 12 | 11 | 10 | 9 | 8 |
| PID15 | PID14 | PID13 | PID12 | PID11 | PID10 | PID9 | PID8 |
| 7 | 6 | 5 | 4 | 3 | 2 | 1 | 0 |
| PID7 | PID6 | PID5 | PID4 | PID3 | PID2 | - | - |

- **PIDx: Peripheral Clock x Enable**

0: No effect.

1: Enables the corresponding peripheral clock.

Note: PID2 to PID31 refer to identifiers as defined in the section “Peripheral Identifiers” in the product datasheet.

Note: Programming the control bits of the Peripheral ID that are not implemented has no effect on the behavior of the PMC.

24.9.5 PMC Peripheral Clock Disable Register

Name: PMC_PCDR

Address: 0xFFFFFC14

Access: Write-only

| | | | | | | | |
|-------|-------|-------|-------|-------|-------|-------|-------|
| 31 | 30 | 29 | 28 | 27 | 26 | 25 | 24 |
| PID31 | PID30 | PID29 | PID28 | PID27 | PID26 | PID25 | PID24 |
| 23 | 22 | 21 | 20 | 19 | 18 | 17 | 16 |
| PID23 | PID22 | PID21 | PID20 | PID19 | PID18 | PID17 | PID16 |
| 15 | 14 | 13 | 12 | 11 | 10 | 9 | 8 |
| PID15 | PID14 | PID13 | PID12 | PID11 | PID10 | PID9 | PID8 |
| 7 | 6 | 5 | 4 | 3 | 2 | 1 | 0 |
| PID7 | PID6 | PID5 | PID4 | PID3 | PID2 | - | - |

- **PIDx: Peripheral Clock x Disable**

0: No effect.

1: Disables the corresponding peripheral clock.

Note: PID2 to PID31 refer to identifiers as defined in the section "Peripheral Identifiers" in the product datasheet.

24.9.6 PMC Peripheral Clock Status Register

Name: PMC_PCSR

Address: 0xFFFFFC18

Access: Read-only

| | | | | | | | |
|-------|-------|-------|-------|-------|-------|-------|-------|
| 31 | 30 | 29 | 28 | 27 | 26 | 25 | 24 |
| PID31 | PID30 | PID29 | PID28 | PID27 | PID26 | PID25 | PID24 |
| 23 | 22 | 21 | 20 | 19 | 18 | 17 | 16 |
| PID23 | PID22 | PID21 | PID20 | PID19 | PID18 | PID17 | PID16 |
| 15 | 14 | 13 | 12 | 11 | 10 | 9 | 8 |
| PID15 | PID14 | PID13 | PID12 | PID11 | PID10 | PID9 | PID8 |
| 7 | 6 | 5 | 4 | 3 | 2 | 1 | 0 |
| PID7 | PID6 | PID5 | PID4 | PID3 | PID2 | – | – |

- **PIDx: Peripheral Clock x Status**

0: The corresponding peripheral clock is disabled.

1: The corresponding peripheral clock is enabled.

Note: PID2 to PID31 refer to identifiers as defined in the section “Peripheral Identifiers” in the product datasheet.

24.9.7 PMC Clock Generator Main Oscillator Register

Name: CKGR_MOR

Address: 0xFFFFFC20

Access: Read/Write

| | | | | | | | |
|-----------|----|----|----|----|----|-----------|--------|
| 31 | 30 | 29 | 28 | 27 | 26 | 25 | 24 |
| – | – | – | – | – | – | – | – |
| 23 | 22 | 21 | 20 | 19 | 18 | 17 | 16 |
| – | – | – | – | – | – | – | – |
| 15 | 14 | 13 | 12 | 11 | 10 | 9 | 8 |
| OSCOUNTER | | | | | | | |
| 7 | 6 | 5 | 4 | 3 | 2 | 1 | 0 |
| – | – | – | – | – | – | OSCBYPASS | MOSCEN |

- **MOSCEN: Main Oscillator Enable**

A crystal must be connected between XIN and XOUT.

0: The Main Oscillator is disabled.

1: The Main Oscillator is enabled. OSCBYPASS must be set to 0.

When MOSCEN is set, the MOSCS flag is set once the Main Oscillator startup time is achieved.

- **OSCBYPASS: Oscillator Bypass**

0: No effect.

1: The Main Oscillator is bypassed. MOSCEN must be set to 0. An external clock must be connected on XIN.

When OSCBYPASS is set, the MOSCS flag in PMC_SR is automatically set.

Clearing MOSCEN and OSCBYPASS bits allows resetting the MOSCS flag.

- **OSCOUNTER: Main Oscillator Startup Time**

Specifies the number of Slow Clock cycles multiplied by 8 for the Main Oscillator startup time.

24.9.8 PMC Clock Generator Main Clock Frequency Register

Name: CKGR_MCFR

Address: 0xFFFFFC24

Access: Read-only

| | | | | | | | |
|-------|----|----|----|----|----|----|---------|
| 31 | 30 | 29 | 28 | 27 | 26 | 25 | 24 |
| – | – | – | – | – | – | – | – |
| 23 | 22 | 21 | 20 | 19 | 18 | 17 | 16 |
| – | – | – | – | – | – | – | MAINRDY |
| 15 | 14 | 13 | 12 | 11 | 10 | 9 | 8 |
| MAINF | | | | | | | |
| 7 | 6 | 5 | 4 | 3 | 2 | 1 | 0 |
| MAINF | | | | | | | |

- **MAINF: Main Clock Frequency**

Gives the number of Main Clock cycles within 16 Slow Clock periods.

- **MAINRDY: Main Clock Ready**

0: MAINF value is not valid or the Main Oscillator is disabled.

1: The Main Oscillator has been enabled previously and MAINF value is available.

24.9.9 PMC Clock Generator PLL A Register

Name: CKGR_PLLAR

Address: 0xFFFFFC28

Access: Read/Write

| | | | | | | | |
|------|----|-----------|----|----|------|----|----|
| 31 | 30 | 29 | 28 | 27 | 26 | 25 | 24 |
| – | – | 1 | – | – | MULA | | |
| 23 | 22 | 21 | 20 | 19 | 18 | 17 | 16 |
| MULA | | | | | | | |
| 15 | 14 | 13 | 12 | 11 | 10 | 9 | 8 |
| OUTA | | PLLACOUNT | | | | | |
| 7 | 6 | 5 | 4 | 3 | 2 | 1 | 0 |
| DIVA | | | | | | | |

Possible limitations on PLL A input frequencies and multiplier factors should be checked before using the PMC.

Warning: Bit 29 must always be set to 1 when programming the CKGR_PLLAR.

- **DIVA: Divider A**

| Value | Divider Selected |
|-------|---|
| 0 | Divider output is 0 |
| 1 | Divider is bypassed |
| 2–255 | Divider output is the Main Clock divided by DIVA. |

- **PLLACOUNT: PLL A Counter**

Specifies the number of Slow Clock cycles before the LOCKA bit is set in PMC_SR after CKGR_PLLAR is written.

- **OUTA: PLL A Clock Frequency Range**

To optimize clock performance, this field must be programmed as specified in “PLL Characteristics” in the Electrical Characteristics section of the product datasheet.

- **MULA: PLL A Multiplier**

0: The PLL A is deactivated.

1 up to 2047 = The PLL A Clock frequency is the PLL A input frequency multiplied by MULA + 1.

24.9.10 PMC Clock Generator PLL B Register

Name: CKGR_PLLBR

Address: 0xFFFFFC2C

Access: Read/Write

| | | | | | | | |
|------|----|-----------|----|----|------|----|----|
| 31 | 30 | 29 | 28 | 27 | 26 | 25 | 24 |
| – | – | USBDIV | | – | MULB | | |
| 23 | 22 | 21 | 20 | 19 | 18 | 17 | 16 |
| MULB | | | | | | | |
| 15 | 14 | 13 | 12 | 11 | 10 | 9 | 8 |
| OUTB | | PLLBCOUNT | | | | | |
| 7 | 6 | 5 | 4 | 3 | 2 | 1 | 0 |
| DIVB | | | | | | | |

Possible limitations on PLL B input frequencies and multiplier factors should be checked before using the PMC.

• DIVB: Divider B

| Value | Divider Selected |
|-------|---|
| 0 | Divider output is 0 |
| 1 | Divider is bypassed |
| 2–255 | Divider output is the selected clock divided by DIVB. |

• PLLBCOUNT: PLL B Counter

Specifies the number of slow clock cycles before the LOCKB bit is set in PMC_SR after CKGR_PLLBR is written.

• OUTB: PLLB Clock Frequency Range

To optimize clock performance, this field must be programmed as specified in “PLL Characteristics” in the Electrical Characteristics section of the product datasheet.

• MULB: PLL Multiplier

0: The PLL B is deactivated.

1 up to 2047 = The PLL B Clock frequency is the PLL B input frequency multiplied by MULB + 1.

• USBDIV: Divider for USB Clock

| Value | Divider for USB Clock(s) |
|-------|--|
| 0 0 | Divider output is PLL B clock output. |
| 0 1 | Divider output is PLL B clock output divided by 2. |
| 1 0 | Divider output is PLL B clock output divided by 4. |
| 1 1 | Reserved. |

24.9.11 PMC Master Clock Register

Name: PMC_MCKR

Address: 0xFFFFFC30

Access: Read/Write

| | | | | | | | |
|----|----|----|------|----|----|------|----|
| 31 | 30 | 29 | 28 | 27 | 26 | 25 | 24 |
| – | – | – | – | – | – | – | – |
| 23 | 22 | 21 | 20 | 19 | 18 | 17 | 16 |
| – | – | – | – | – | – | – | – |
| 15 | 14 | 13 | 12 | 11 | 10 | 9 | 8 |
| – | – | – | – | – | – | MDIV | |
| 7 | 6 | 5 | 4 | 3 | 2 | 1 | 0 |
| – | – | – | PRES | | | CSS | |

• CSS: Master Clock Selection

| Value | Clock Source Selection |
|-------|-------------------------|
| 0 0 | Slow Clock is selected |
| 0 1 | Main Clock is selected |
| 1 0 | PLL A Clock is selected |
| 1 1 | PLL B Clock is selected |

• PRES: Processor Clock Prescaler

| Value | Processor Clock |
|-------|------------------------------|
| 0 0 0 | Selected clock |
| 0 0 1 | Selected clock divided by 2 |
| 0 1 0 | Selected clock divided by 4 |
| 0 1 1 | Selected clock divided by 8 |
| 1 0 0 | Selected clock divided by 16 |
| 1 0 1 | Selected clock divided by 32 |
| 1 1 0 | Selected clock divided by 64 |
| 1 1 1 | Reserved |

• MDIV: Master Clock Division

| Value | Master Clock Division |
|-------|---|
| 0 0 | Master Clock is Processor Clock. |
| 0 1 | Master Clock is Processor Clock divided by 2. |
| 1 0 | Master Clock is Processor Clock divided by 4. |
| 1 1 | Reserved. |

24.9.12 PMC Programmable Clock Register

Name: PMC_PCKx
Address: 0xFFFFFC40
Access: Read/Write

| | | | | | | | |
|----|----|----|------|----|----|-----|----|
| 31 | 30 | 29 | 28 | 27 | 26 | 25 | 24 |
| – | – | – | – | – | – | – | – |
| 23 | 22 | 21 | 20 | 19 | 18 | 17 | 16 |
| – | – | – | – | – | – | – | – |
| 15 | 14 | 13 | 12 | 11 | 10 | 9 | 8 |
| – | – | – | – | – | – | – | – |
| 7 | 6 | 5 | 4 | 3 | 2 | 1 | 0 |
| – | – | – | PRES | | | CSS | |

• CSS: Master Clock Selection

| Value | Clock Source Selection |
|-------|-------------------------|
| 0 0 | Slow Clock is selected |
| 0 1 | Main Clock is selected |
| 1 0 | PLL A Clock is selected |
| 1 1 | PLL B Clock is selected |

• PRES: Programmable Clock Prescaler

| Value | Programmable Clock |
|-------|------------------------------|
| 0 0 0 | Selected clock |
| 0 0 1 | Selected clock divided by 2 |
| 0 1 0 | Selected clock divided by 4 |
| 0 1 1 | Selected clock divided by 8 |
| 1 0 0 | Selected clock divided by 16 |
| 1 0 1 | Selected clock divided by 32 |
| 1 1 0 | Selected clock divided by 64 |
| 1 1 1 | Reserved |

24.9.13 PMC Interrupt Enable Register

Name: PMC_IER

Address: 0xFFFFFC60

Access: Write-only

| | | | | | | | |
|----|----|----|----|---------|---------|---------|---------|
| 31 | 30 | 29 | 28 | 27 | 26 | 25 | 24 |
| – | – | – | – | – | – | – | – |
| 23 | 22 | 21 | 20 | 19 | 18 | 17 | 16 |
| – | – | – | – | – | – | – | – |
| 15 | 14 | 13 | 12 | 11 | 10 | 9 | 8 |
| – | – | – | – | PCKRDY3 | PCKRDY2 | PCKRDY1 | PCKRDY0 |
| 7 | 6 | 5 | 4 | 3 | 2 | 1 | 0 |
| – | – | – | – | MCKRDY | LOCKB | LOCKA | MOSCS |

- **MOSCS: Main Oscillator Status Interrupt Enable**
- **LOCKA: PLL A Lock Interrupt Enable**
- **LOCKB: PLL B Lock Interrupt Enable**
- **MCKRDY: Master Clock Ready Interrupt Enable**
- **PCKRDYx: Programmable Clock Ready x Interrupt Enable**

0: No effect.

1: Enables the corresponding interrupt.

24.9.14 PMC Interrupt Disable Register

Name: PMC_IDR

Address: 0xFFFFFC64

Access: Write-only

| | | | | | | | |
|----|----|----|----|---------|---------|---------|---------|
| 31 | 30 | 29 | 28 | 27 | 26 | 25 | 24 |
| – | – | – | – | – | – | – | – |
| 23 | 22 | 21 | 20 | 19 | 18 | 17 | 16 |
| – | – | – | – | – | – | – | – |
| 15 | 14 | 13 | 12 | 11 | 10 | 9 | 8 |
| – | – | – | – | PCKRDY3 | PCKRDY2 | PCKRDY1 | PCKRDY0 |
| 7 | 6 | 5 | 4 | 3 | 2 | 1 | 0 |
| – | – | – | – | MCKRDY | LOCKB | LOCKA | MOSCS |

- **MOSCS: Main Oscillator Status Interrupt Disable**
- **LOCKA: PLL A Lock Interrupt Disable**
- **LOCKB: PLL B Lock Interrupt Disable**
- **MCKRDY: Master Clock Ready Interrupt Disable**
- **PCKRDYx: Programmable Clock Ready x Interrupt Disable**

0: No effect.

1: Disables the corresponding interrupt.

24.9.15 PMC Status Register

Name: PMC_SR

Address: 0xFFFFFC68

Access: Read-only

| | | | | | | | |
|----|----|----|----|---------|---------|---------|---------|
| 31 | 30 | 29 | 28 | 27 | 26 | 25 | 24 |
| – | – | – | – | – | – | – | – |
| 23 | 22 | 21 | 20 | 19 | 18 | 17 | 16 |
| – | – | – | – | – | – | – | – |
| 15 | 14 | 13 | 12 | 11 | 10 | 9 | 8 |
| – | – | – | – | PCKRDY3 | PCKRDY2 | PCKRDY1 | PCKRDY0 |
| 7 | 6 | 5 | 4 | 3 | 2 | 1 | 0 |
| – | – | – | – | MCKRDY | LOCKB | LOCKA | MOSCS |

- **MOSCS: MOSCS Flag Status**

0: Main oscillator is not stabilized.

1: Main oscillator is stabilized.

- **LOCKA: PLL A Lock Status**

0: PLL A is not locked

1: PLL A is locked.

- **LOCKB: PLL B Lock Status**

0: PLL B is not locked.

1: PLL B is locked.

- **MCKRDY: Master Clock Status**

0: Master Clock is not ready.

1: Master Clock is ready.

- **PCKRDYx: Programmable Clock Ready Status**

0: Programmable Clock x is not ready.

1: Programmable Clock x is ready.

24.9.16 PMC Interrupt Mask Register

Name: PMC_IMR

Address: 0xFFFFFC6C

Access: Read-only

| | | | | | | | |
|----|----|----|----|---------|---------|---------|---------|
| 31 | 30 | 29 | 28 | 27 | 26 | 25 | 24 |
| – | – | – | – | – | – | – | – |
| 23 | 22 | 21 | 20 | 19 | 18 | 17 | 16 |
| – | – | – | – | – | – | – | – |
| 15 | 14 | 13 | 12 | 11 | 10 | 9 | 8 |
| – | – | – | – | PCKRDY3 | PCKRDY2 | PCKRDY1 | PCKRDY0 |
| 7 | 6 | 5 | 4 | 3 | 2 | 1 | 0 |
| – | – | – | – | MCKRDY | LOCKB | LOCKA | MOSCS |

- **MOSCS: Main Oscillator Status Interrupt Mask**
- **LOCKA: PLL A Lock Interrupt Mask**
- **LOCKB: PLL B Lock Interrupt Mask**
- **MCKRDY: Master Clock Ready Interrupt Mask**
- **PCKRDYx: Programmable Clock Ready x Interrupt Mask**

0: The corresponding interrupt is enabled.

1: The corresponding interrupt is disabled.

24.9.17 PLL Charge Pump Current Register

Name: PMC_PLLICPR

Address: 0xFFFFFC80

Access: Read/Write

| | | | | | | | |
|----|----|----|----|----|----|----|----------|
| 31 | 30 | 29 | 28 | 27 | 26 | 25 | 24 |
| – | – | – | – | – | – | – | – |
| 23 | 22 | 21 | 20 | 19 | 18 | 17 | 16 |
| – | – | – | – | – | – | – | ICPPLL B |
| 15 | 14 | 13 | 12 | 11 | 10 | 9 | 8 |
| – | – | – | – | – | – | – | – |
| 7 | 6 | 5 | 4 | 3 | 2 | 1 | 0 |
| – | – | – | – | – | – | – | ICPPLL A |

- **ICPPLLA: Charge pump current**

Must be set to 1.

- **ICPPLLB: Charge pump current**

Must be set to 1.

25.4 Functional Description

The Watchdog Timer can be used to prevent system lock-up if the software becomes trapped in a deadlock. It is supplied with VDDCORE. It restarts with initial values on processor reset.

The Watchdog is built around a 12-bit down counter, which is loaded with the value defined in the field WDV of the Mode Register (WDT_MR). The Watchdog Timer uses the Slow Clock divided by 128 to establish the maximum Watchdog period to be 16 seconds (with a typical Slow Clock of 32.768 kHz).

After a Processor Reset, the value of WDV is 0xFFF, corresponding to the maximum value of the counter with the external reset generation enabled (field WDRSTEN at 1 after a Backup Reset). This means that a default Watchdog is running at reset, i.e., at powerup. The user must either disable it (by setting the WDDIS bit in WDT_MR) if he does not expect to use it or must reprogram it to meet the maximum Watchdog period the application requires.

The Watchdog Mode Register (WDT_MR) can be written only once. Only a processor reset resets it. Writing the WDT_MR reloads the timer with the newly programmed mode parameters.

In normal operation, the user reloads the Watchdog at regular intervals before the timer underflow occurs, by writing the Control Register (WDT_CR) with the bit WDRSTT to 1. The Watchdog counter is then immediately reloaded from WDT_MR and restarted, and the Slow Clock 128 divider is reset and restarted. The WDT_CR is write-protected. As a result, writing WDT_CR without the correct hard-coded key has no effect. If an underflow does occur, the “wdt_fault” signal to the Reset Controller is asserted if the bit WDRSTEN is set in the Mode Register (WDT_MR). Moreover, the bit WDUNF is set in the Watchdog Status Register (WDT_SR).

To prevent a software deadlock that continuously triggers the Watchdog, the reload of the Watchdog must occur while the Watchdog counter is within a window between 0 and WDD, WDD is defined in the WatchDog Mode Register WDT_MR.

Any attempt to restart the Watchdog while the Watchdog counter is between WDV and WDD results in a Watchdog error, even if the Watchdog is disabled. The bit WDERR is updated in the WDT_SR and the “wdt_fault” signal to the Reset Controller is asserted.

Note that this feature can be disabled by programming a WDD value greater than or equal to the WDV value. In such a configuration, restarting the Watchdog Timer is permitted in the whole range [0; WDV] and does not generate an error. This is the default configuration on reset (the WDD and WDV values are equal).

The status bits WDUNF (Watchdog Underflow) and WDERR (Watchdog Error) trigger an interrupt, provided the bit WDFIEN is set in the mode register. The signal “wdt_fault” to the reset controller causes a Watchdog reset if the WDRSTEN bit is set as already explained in the reset controller programmer Datasheet. In that case, the processor and the Watchdog Timer are reset, and the WDERR and WDUNF flags are reset.

If a reset is generated or if WDT_SR is read, the status bits are reset, the interrupt is cleared, and the “wdt_fault” signal to the reset controller is deasserted.

Writing the WDT_MR reloads and restarts the down counter.

While the processor is in debug state or in idle mode, the counter may be stopped depending on the value programmed for the bits WDIDLEHLT and WDBGHLT in the WDT_MR.

Figure 25-2. Watchdog Behavior

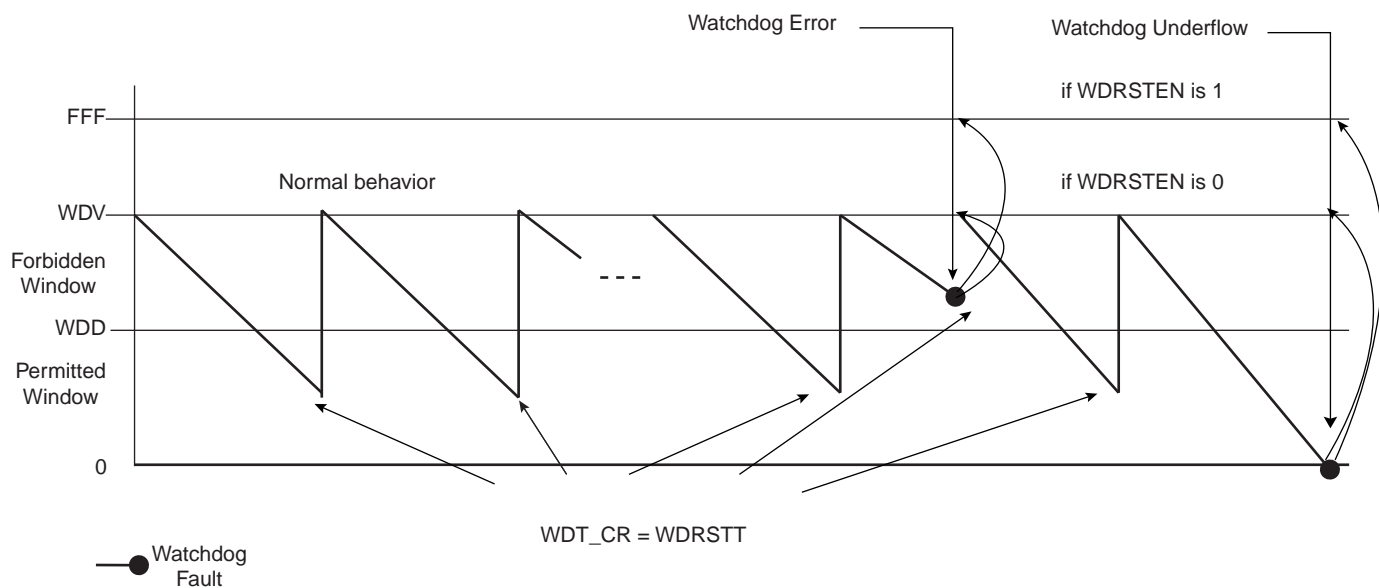

25.5 Watchdog Timer (WDT) User Interface

Table 25-1. Register Mapping

| Offset | Register | Name | Access | Reset |
|--------|------------------|--------|-----------------|-------------|
| 0x00 | Control Register | WDT_CR | Write-only | – |
| 0x04 | Mode Register | WDT_MR | Read-write Once | 0x3FFF_2FFF |
| 0x08 | Status Register | WDT_SR | Read-only | 0x0000_0000 |

25.5.1 Watchdog Timer Control Register

Name: WDT_CR

Address: 0xFFFFFD40

Access: Write-only

| | | | | | | | |
|-----|----|----|----|----|----|----|--------|
| 31 | 30 | 29 | 28 | 27 | 26 | 25 | 24 |
| KEY | | | | | | | |
| 23 | 22 | 21 | 20 | 19 | 18 | 17 | 16 |
| - | - | - | - | - | - | - | - |
| 15 | 14 | 13 | 12 | 11 | 10 | 9 | 8 |
| - | - | - | - | - | - | - | - |
| 7 | 6 | 5 | 4 | 3 | 2 | 1 | 0 |
| - | - | - | - | - | - | - | WDRSTT |

- **WDRSTT: Watchdog Restart**

0: No effect.

1: Restarts the Watchdog.

- **KEY: Password**

Should be written at value 0xA5. Writing any other value in this field aborts the write operation.

25.5.2 Watchdog Timer Mode Register

Name: WDT_MR

Address: 0xFFFFFD44

Access: Read-write Once

| | | | | | | | |
|-------|---------|-----------|----------|-----|----|----|----|
| 31 | 30 | 29 | 28 | 27 | 26 | 25 | 24 |
| | | WDIDLEHLT | WDDBGHLT | WDD | | | |
| 23 | 22 | 21 | 20 | 19 | 18 | 17 | 16 |
| WDD | | | | | | | |
| 15 | 14 | 13 | 12 | 11 | 10 | 9 | 8 |
| WDDIS | WDRPROC | WDRSTEN | WDFIEN | WDV | | | |
| 7 | 6 | 5 | 4 | 3 | 2 | 1 | 0 |
| WDV | | | | | | | |

- **WDV: Watchdog Counter Value**

Defines the value loaded in the 12-bit Watchdog Counter.

- **WDFIEN: Watchdog Fault Interrupt Enable**

0: A Watchdog fault (underflow or error) has no effect on interrupt.

1: A Watchdog fault (underflow or error) asserts interrupt.

- **WDRSTEN: Watchdog Reset Enable**

0: A Watchdog fault (underflow or error) has no effect on the resets.

1: A Watchdog fault (underflow or error) triggers a Watchdog reset.

- **WDRPROC: Watchdog Reset Processor**

0: If WDRSTEN is 1, a Watchdog fault (underflow or error) activates all resets.

1: If WDRSTEN is 1, a Watchdog fault (underflow or error) activates the processor reset.

- **WDD: Watchdog Delta Value**

Defines the permitted range for reloading the Watchdog Timer.

If the Watchdog Timer value is less than or equal to WDD, writing WDT_CR with WDRSTT = 1 restarts the timer.

If the Watchdog Timer value is greater than WDD, writing WDT_CR with WDRSTT = 1 causes a Watchdog error.

- **WDDBGHLT: Watchdog Debug Halt**

0: The Watchdog runs when the processor is in debug state.

1: The Watchdog stops when the processor is in debug state.

- **WDIDLEHLT: Watchdog Idle Halt**

0: The Watchdog runs when the system is in idle mode.

1: The Watchdog stops when the system is in idle state.

- **WDDIS: Watchdog Disable**

0: Enables the Watchdog Timer.

1: Disables the Watchdog Timer.

25.5.3 Watchdog Timer Status Register

Name: WDT_SR

Address: 0xFFFFFD48

Access: Read-only

| | | | | | | | |
|----|----|----|----|----|----|-------|-------|
| 31 | 30 | 29 | 28 | 27 | 26 | 25 | 24 |
| – | – | – | – | – | – | – | – |
| 23 | 22 | 21 | 20 | 19 | 18 | 17 | 16 |
| – | – | – | – | – | – | – | – |
| 15 | 14 | 13 | 12 | 11 | 10 | 9 | 8 |
| – | – | – | – | – | – | – | – |
| 7 | 6 | 5 | 4 | 3 | 2 | 1 | 0 |
| – | – | – | – | – | – | WDERR | WDUNF |

- **WDUNF: Watchdog Underflow**

0: No Watchdog underflow occurred since the last read of WDT_SR.

1: At least one Watchdog underflow occurred since the last read of WDT_SR.

- **WDERR: Watchdog Error**

0: No Watchdog error occurred since the last read of WDT_SR.

1: At least one Watchdog error occurred since the last read of WDT_SR.

26. Advanced Interrupt Controller (AIC)

26.1 Overview

The Advanced Interrupt Controller (AIC) is an 8-level priority, individually maskable, vectored interrupt controller, providing handling of up to thirty-two interrupt sources. It is designed to substantially reduce the software and real-time overhead in handling internal and external interrupts.

The AIC drives the nFIQ (fast interrupt request) and the nIRQ (standard interrupt request) inputs of an ARM processor. Inputs of the AIC are either internal peripheral interrupts or external interrupts coming from the product's pins.

The 8-level Priority Controller allows the user to define the priority for each interrupt source, thus permitting higher priority interrupts to be serviced even if a lower priority interrupt is being treated.

Internal interrupt sources can be programmed to be level sensitive or edge triggered. External interrupt sources can be programmed to be positive-edge or negative-edge triggered or high-level or low-level sensitive.

The fast forcing feature redirects any internal or external interrupt source to provide a fast interrupt rather than a normal interrupt.

26.2 Block Diagram

Figure 26-1. Block Diagram

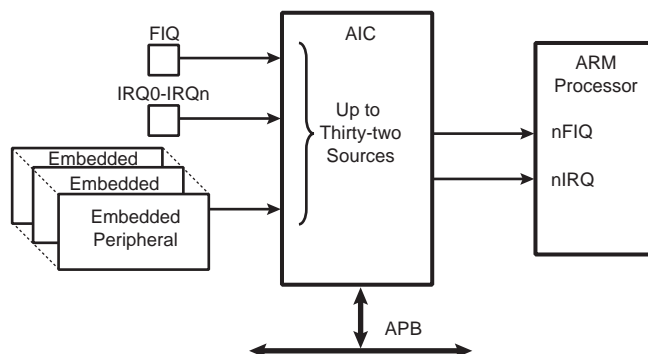

26.3 Application Block Diagram

Figure 26-2. Description of the Application Block

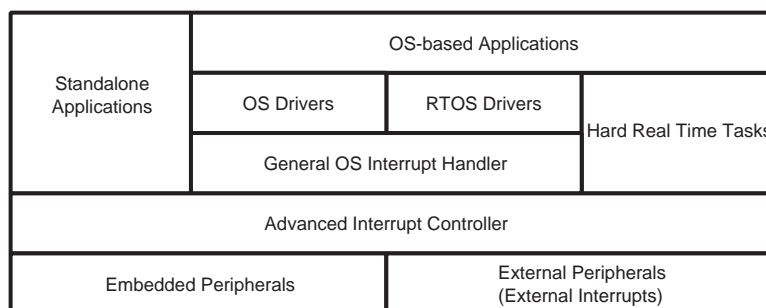

26.4 AIC Detailed Block Diagram

Figure 26-3. AIC Detailed Block Diagram

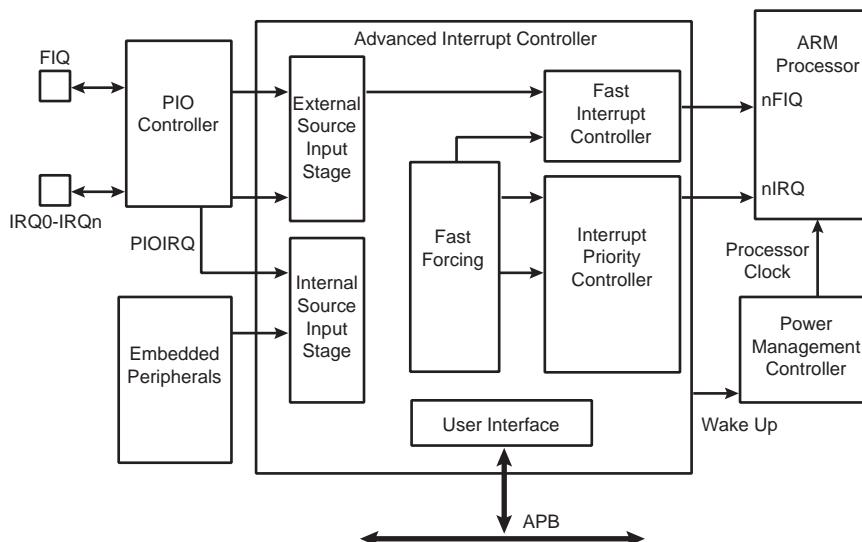

26.5 I/O Line Description

Table 26-1. I/O Line Description

| Pin Name | Pin Description | Type |
|-----------|-------------------------|-------|
| FIQ | Fast Interrupt | Input |
| IRQ0-IRQn | Interrupt 0-Interrupt n | Input |

26.6 Product Dependencies

26.6.1 I/O Lines

The interrupt signals FIQ and IRQ0 to IRQn are normally multiplexed through the PIO controllers. Depending on the features of the PIO controller used in the product, the pins must be programmed in accordance with their assigned interrupt function. This is not applicable when the PIO controller used in the product is transparent on the input path.

26.6.2 Power Management

The Advanced Interrupt Controller is continuously clocked. The Power Management Controller has no effect on the Advanced Interrupt Controller behavior.

The assertion of the Advanced Interrupt Controller outputs, either nIRQ or nFIQ, wakes up the ARM processor while it is in Idle Mode. The General Interrupt Mask feature enables the AIC to wake up the processor without asserting the interrupt line of the processor, thus providing synchronization of the processor on an event.

26.6.3 Interrupt Sources

The Interrupt Source 0 is always located at FIQ. If the product does not feature an FIQ pin, the Interrupt Source 0 cannot be used.

The Interrupt Source 1 is always located at System Interrupt. This is the result of the OR-wiring of the system peripheral interrupt lines. When a system interrupt occurs, the service routine must first distinguish the cause of

the interrupt. This is performed by reading successively the status registers of the above mentioned system peripherals.

The interrupt sources 2 to 31 can either be connected to the interrupt outputs of an embedded user peripheral or to external interrupt lines. The external interrupt lines can be connected directly, or through the PIO Controller.

The PIO Controllers are considered as user peripherals in the scope of interrupt handling. Accordingly, the PIO Controller interrupt lines are connected to the Interrupt Sources 2 to 31.

The peripheral identification defined at the product level corresponds to the interrupt source number (as well as the bit number controlling the clock of the peripheral). Consequently, to simplify the description of the functional operations and the user interface, the interrupt sources are named FIQ, SYS, and PID2 to PID31.

26.7 Functional Description

26.7.1 Interrupt Source Control

26.7.1.1 Interrupt Source Mode

The Advanced Interrupt Controller independently programs each interrupt source. The SRCTYPE field of the corresponding AIC_SMR (Source Mode Register) selects the interrupt condition of each source.

The internal interrupt sources wired on the interrupt outputs of the embedded peripherals can be programmed either in level-sensitive mode or in edge-triggered mode. The active level of the internal interrupts is not important for the user.

The external interrupt sources can be programmed either in high level-sensitive or low level-sensitive modes, or in positive edge-triggered or negative edge-triggered modes.

26.7.1.2 Interrupt Source Enabling

Each interrupt source, including the FIQ in source 0, can be enabled or disabled by using the command registers; AIC_I ECR (Interrupt Enable Command Register) and AIC_IDCR (Interrupt Disable Command Register). This set of registers conducts enabling or disabling in one instruction. The interrupt mask can be read in the AIC_IMR. A disabled interrupt does not affect servicing of other interrupts.

26.7.1.3 Interrupt Clearing and Setting

All interrupt sources programmed to be edge-triggered (including the FIQ in source 0) can be individually set or cleared by writing respectively the AIC_ISCR and AIC_ICCRs. Clearing or setting interrupt sources programmed in level-sensitive mode has no effect.

The clear operation is perfunctory, as the software must perform an action to reinitialize the “memorization” circuitry activated when the source is programmed in edge-triggered mode. However, the set operation is available for auto-test or software debug purposes. It can also be used to execute an AIC-implementation of a software interrupt.

The AIC features an automatic clear of the current interrupt when the AIC_IVR (Interrupt Vector Register) is read. Only the interrupt source being detected by the AIC as the current interrupt is affected by this operation. (See [“Priority Controller” on page 276.](#)) The automatic clear reduces the operations required by the interrupt service routine entry code to reading the AIC_IVR. Note that the automatic interrupt clear is disabled if the interrupt source has the Fast Forcing feature enabled as it is considered uniquely as a FIQ source. (For further details, See [“Fast Forcing” on page 279.](#))

The automatic clear of the interrupt source 0 is performed when AIC_FVR is read.

26.7.1.4 Interrupt Status

For each interrupt, the AIC operation originates in AIC_IPR (Interrupt Pending Register) and its mask in AIC_IMR (Interrupt Mask Register). AIC_IPR enables the actual activity of the sources, whether masked or not.

The AIC_ISR reads the number of the current interrupt (see “Priority Controller” on page 276) and the register AIC_CISR gives an image of the signals nIRQ and nFIQ driven on the processor.

Each status referred to above can be used to optimize the interrupt handling of the systems.

26.7.1.5 Internal Interrupt Source Input Stage

Figure 26-4. Internal Interrupt Source Input Stage

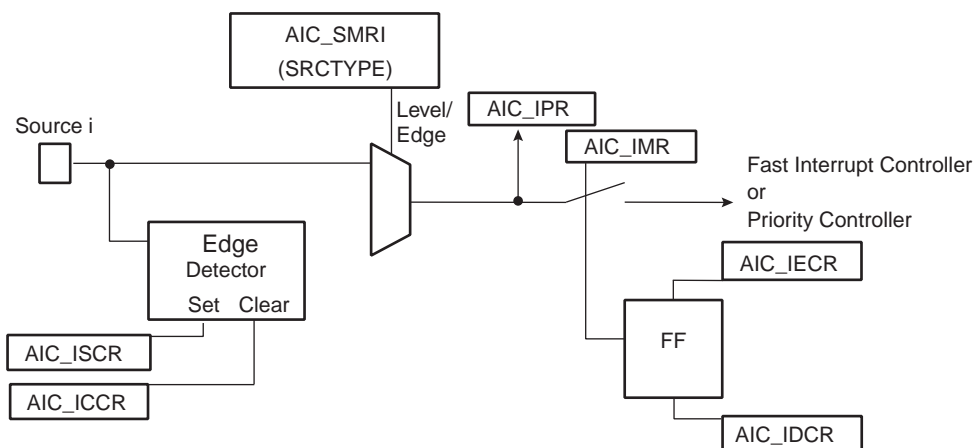

26.7.1.6 External Interrupt Source Input Stage

Figure 26-5. External Interrupt Source Input Stage

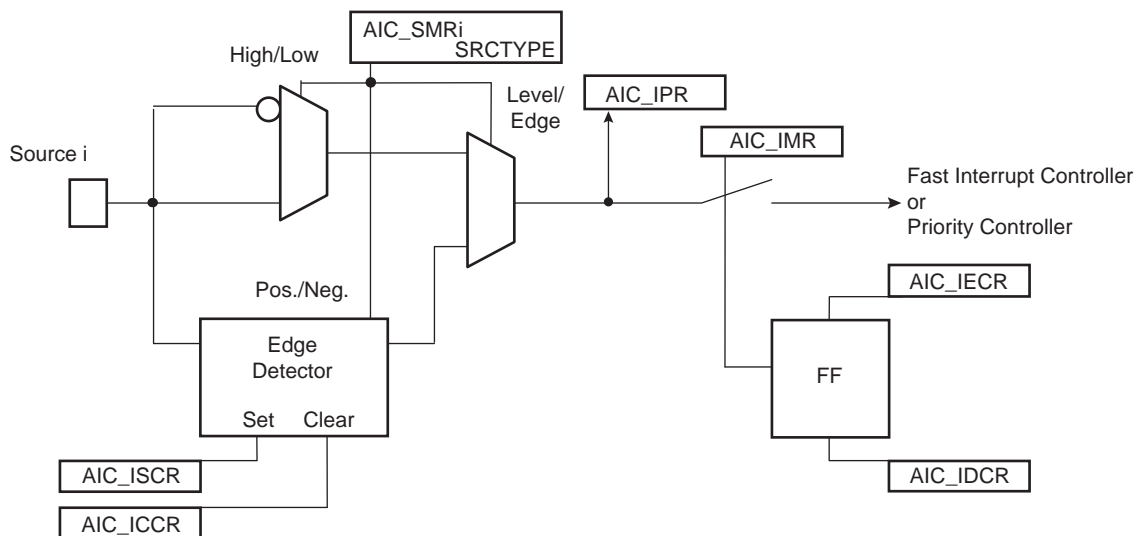

26.7.2 Interrupt Latencies

Global interrupt latencies depend on several parameters, including:

- The time the software masks the interrupts.
- Occurrence, either at the processor level or at the AIC level.
- The execution time of the instruction in progress when the interrupt occurs.
- The treatment of higher priority interrupts and the resynchronization of the hardware signals.

This section addresses only the hardware resynchronizations. It gives details of the latency times between the event on an external interrupt leading in a valid interrupt (edge or level) or the assertion of an internal interrupt source and the assertion of the nIRQ or nFIQ line on the processor. The resynchronization time depends on the programming of the interrupt source and on its type (internal or external). For the standard interrupt, resynchronization times are given assuming there is no higher priority in progress.

The PIO Controller multiplexing has no effect on the interrupt latencies of the external interrupt sources.

26.7.2.1 External Interrupt Edge Triggered Source

Figure 26-6. External Interrupt Edge Triggered Source

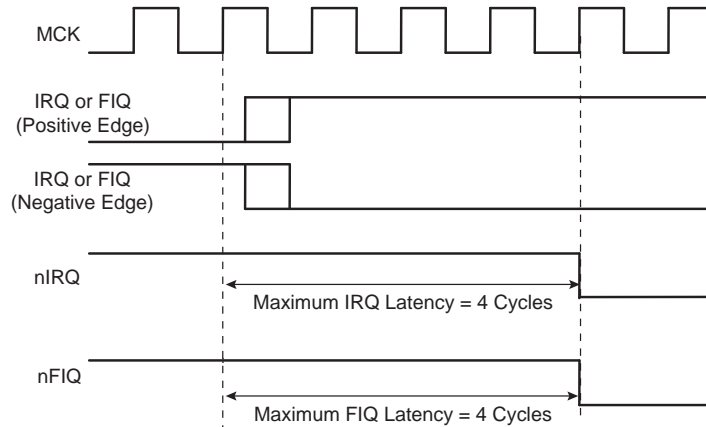

26.7.2.2 External Interrupt Level Sensitive Source

Figure 26-7. External Interrupt Level Sensitive Source

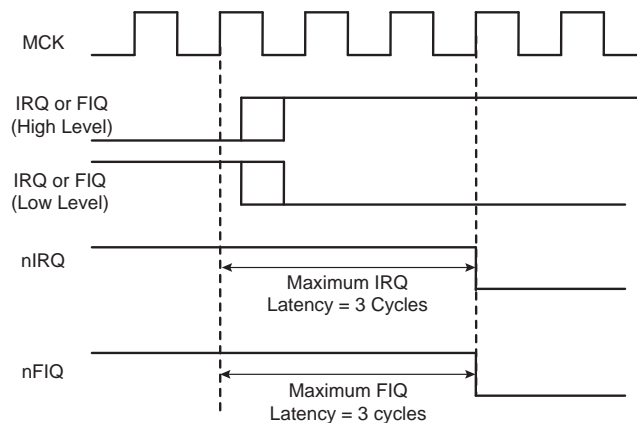

26.7.2.3 Internal Interrupt Edge Triggered Source

Figure 26-8. Internal Interrupt Edge Triggered Source

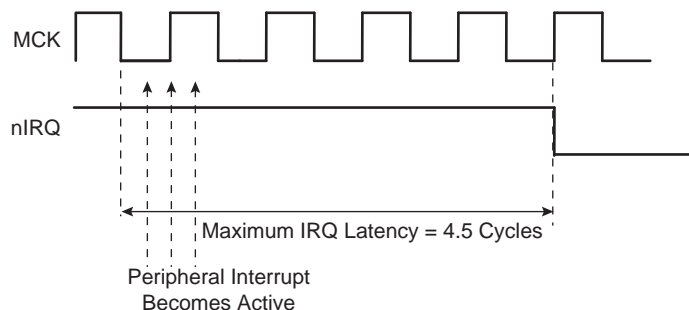

26.7.2.4 Internal Interrupt Level Sensitive Source

Figure 26-9. Internal Interrupt Level Sensitive Source

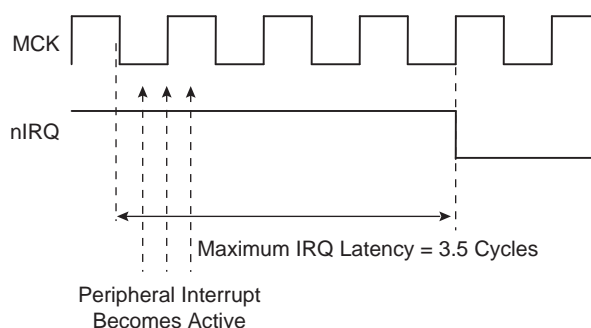

26.7.3 Normal Interrupt

26.7.3.1 Priority Controller

An 8-level priority controller drives the nIRQ line of the processor, depending on the interrupt conditions occurring on the interrupt sources 1 to 31 (except for those programmed in Fast Forcing).

Each interrupt source has a programmable priority level of 7 to 0, which is user-definable by writing the PRIOR field of the corresponding AIC_SMR (Source Mode Register). Level 7 is the highest priority and level 0 the lowest.

As soon as an interrupt condition occurs, as defined by the SRCTYPE field of the AIC_SMR (Source Mode Register), the nIRQ line is asserted. As a new interrupt condition might have happened on other interrupt sources since the nIRQ has been asserted, the priority controller determines the current interrupt at the time the AIC_IVR (Interrupt Vector Register) is read. **The read of AIC_IVR is the entry point of the interrupt handling** which allows the AIC to consider that the interrupt has been taken into account by the software.

The current priority level is defined as the priority level of the current interrupt.

If several interrupt sources of equal priority are pending and enabled when the AIC_IVR is read, the interrupt with the lowest interrupt source number is serviced first.

The nIRQ line can be asserted only if an interrupt condition occurs on an interrupt source with a higher priority. If an interrupt condition happens (or is pending) during the interrupt treatment in progress, it is delayed until the software indicates to the AIC the end of the current service by writing the AIC_EOICR (End of Interrupt Command Register). **The write of AIC_EOICR is the exit point of the interrupt handling.**

26.7.3.2 Interrupt Nesting

The priority controller utilizes interrupt nesting in order for the high priority interrupt to be handled during the service of lower priority interrupts. This requires the interrupt service routines of the lower interrupts to re-enable the interrupt at the processor level.

When an interrupt of a higher priority happens during an already occurring interrupt service routine, the nIRQ line is re-asserted. If the interrupt is enabled at the core level, the current execution is interrupted and the new interrupt service routine should read the AIC_IVR. At this time, the current interrupt number and its priority level are pushed into an embedded hardware stack, so that they are saved and restored when the higher priority interrupt servicing is finished and the AIC_EOICR is written.

The AIC is equipped with an 8-level wide hardware stack in order to support up to eight interrupt nestings pursuant to having eight priority levels.

26.7.3.3 Interrupt Vectoring

The interrupt handler addresses corresponding to each interrupt source can be stored in the registers AIC_SVR1 to AIC_SVR31 (Source Vector Register 1 to 31). When the processor reads AIC_IVR (Interrupt Vector Register), the value written into AIC_SVR corresponding to the current interrupt is returned.

This feature offers a way to branch in one single instruction to the handler corresponding to the current interrupt, as AIC_IVR is mapped at the absolute address 0xFFFF F100 and thus accessible from the ARM interrupt vector at address 0x0000 0018 through the following instruction:

```
LDR PC, [PC, # -&F20]
```

When the processor executes this instruction, it loads the read value in AIC_IVR in its program counter, thus branching the execution on the correct interrupt handler.

This feature is often not used when the application is based on an operating system (either real time or not). Operating systems often have a single entry point for all the interrupts and the first task performed is to discern the source of the interrupt.

However, it is strongly recommended to port the operating system on AT91 products by supporting the interrupt vectoring. This can be performed by defining all the AIC_SVR of the interrupt source to be handled by the operating system at the address of its interrupt handler. When doing so, the interrupt vectoring permits a critical interrupt to transfer the execution on a specific very fast handler and not onto the operating system's general interrupt handler. This facilitates the support of hard real-time tasks (input/outputs of voice/audio buffers and software peripheral handling) to be handled efficiently and independently of the application running under an operating system.

26.7.3.4 Interrupt Handlers

This section gives an overview of the fast interrupt handling sequence when using the AIC. It is assumed that the programmer understands the architecture of the ARM processor, and especially the processor interrupt modes and the associated status bits.

It is assumed that:

1. The Advanced Interrupt Controller has been programmed, AIC_SVRs are loaded with corresponding interrupt service routine addresses and interrupts are enabled.
2. The instruction at the ARM interrupt exception vector address is required to work with the vectoring

```
LDR PC, [PC, # -&F20]
```

When nIRQ is asserted, if the bit "I" of CPSR is 0, the sequence is as follows:

1. The CPSR is stored in SPSR_irq, the current value of the Program Counter is loaded in the Interrupt link register (R14_irq) and the Program Counter (R15) is loaded with 0x18. In the following cycle during fetch at address 0x1C, the ARM core adjusts R14_irq, decrementing it by four.
2. The ARM core enters Interrupt mode, if it has not already done so.
3. When the instruction loaded at address 0x18 is executed, the program counter is loaded with the value read in AIC_IVR. Reading the AIC_IVR has the following effects:
 - Sets the current interrupt to be the pending and enabled interrupt with the highest priority. The current level is the priority level of the current interrupt.
 - De-asserts the nIRQ line on the processor. Even if vectoring is not used, AIC_IVR must be read in order to de-assert nIRQ.
 - Automatically clears the interrupt, if it has been programmed to be edge-triggered.
 - Pushes the current level and the current interrupt number on to the stack.
 - Returns the value written in the AIC_SVR corresponding to the current interrupt.
4. The previous step has the effect of branching to the corresponding interrupt service routine. This should start by saving the link register (R14_irq) and SPSR_IRQ. The link register must be decremented by four when it

is saved if it is to be restored directly into the program counter at the end of the interrupt. For example, the instruction `SUB PC, LR, #4` may be used.

5. Further interrupts can then be unmasked by clearing the “I” bit in CPSR, allowing re-assertion of the nIRQ to be taken into account by the core. This can happen if an interrupt with a higher priority than the current interrupt occurs.
6. The interrupt handler can then proceed as required, saving the registers that will be used and restoring them at the end. During this phase, an interrupt of higher priority than the current level will restart the sequence from step 1.

Note: If the interrupt is programmed to be level sensitive, the source of the interrupt must be cleared during this phase.

7. The “I” bit in CPSR must be set in order to mask interrupts before exiting to ensure that the interrupt is completed in an orderly manner.
8. The End of Interrupt Command Register (AIC_EOICR) must be written in order to indicate to the AIC that the current interrupt is finished. This causes the current level to be popped from the stack, restoring the previous current level if one exists on the stack. If another interrupt is pending, with lower or equal priority than the old current level but with higher priority than the new current level, the nIRQ line is re-asserted, but the interrupt sequence does not immediately start because the “I” bit is set in the core. SPSR_irq is restored. Finally, the saved value of the link register is restored directly into the PC. This has the effect of returning from the interrupt to whatever was being executed before, and of loading the CPSR with the stored SPSR, masking or unmasking the interrupts depending on the state saved in SPSR_irq.

Note: The “I” bit in SPSR is significant. If it is set, it indicates that the ARM core was on the verge of masking an interrupt when the mask instruction was interrupted. Hence, when SPSR is restored, the mask instruction is completed (interrupt is masked).

26.7.4 Fast Interrupt

26.7.4.1 Fast Interrupt Source

The interrupt source 0 is the only source which can raise a fast interrupt request to the processor except if fast forcing is used. The interrupt source 0 is generally connected to a FIQ pin of the product, either directly or through a PIO Controller.

26.7.4.2 Fast Interrupt Control

The fast interrupt logic of the AIC has no priority controller. The mode of interrupt source 0 is programmed with the AIC_SMR0 and the field PRIOR of this register is not used even if it reads what has been written. The field SRCTYPE of AIC_SMR0 enables programming the fast interrupt source to be positive-edge triggered or negative-edge triggered or high-level sensitive or low-level sensitive

Writing 0x1 in the AIC_IECR (Interrupt Enable Command Register) and AIC_IDCR (Interrupt Disable Command Register) respectively enables and disables the fast interrupt. The bit 0 of AIC_IMR (Interrupt Mask Register) indicates whether the fast interrupt is enabled or disabled.

26.7.4.3 Fast Interrupt Vectoring

The fast interrupt handler address can be stored in AIC_SVR0 (Source Vector Register 0). The value written into this register is returned when the processor reads AIC_FVR (Fast Vector Register). This offers a way to branch in one single instruction to the interrupt handler, as AIC_FVR is mapped at the absolute address 0xFFFF F104 and thus accessible from the ARM fast interrupt vector at address 0x0000 001C through the following instruction:

```
LDR          PC, [PC, # -&F20]
```

When the processor executes this instruction it loads the value read in AIC_FVR in its program counter, thus branching the execution on the fast interrupt handler. It also automatically performs the clear of the fast interrupt source if it is programmed in edge-triggered mode.

26.7.4.4 Fast Interrupt Handlers

This section gives an overview of the fast interrupt handling sequence when using the AIC. It is assumed that the programmer understands the architecture of the ARM processor, and especially the processor interrupt modes and associated status bits.

Assuming that:

1. The Advanced Interrupt Controller has been programmed, AIC_SVR0 is loaded with the fast interrupt service routine address, and the interrupt source 0 is enabled.
2. The Instruction at address 0x1C (FIQ exception vector address) is required to vector the fast interrupt:

```
LDR PC, [PC, # -&F20]
```
3. The user does not need nested fast interrupts.

When nFIQ is asserted, if the bit “F” of CPSR is 0, the sequence is:

1. The CPSR is stored in SPSR_fiq, the current value of the program counter is loaded in the FIQ link register (R14_FIQ) and the program counter (R15) is loaded with 0x1C. In the following cycle, during fetch at address 0x20, the ARM core adjusts R14_fiq, decrementing it by four.
2. The ARM core enters FIQ mode.
3. When the instruction loaded at address 0x1C is executed, the program counter is loaded with the value read in AIC_FVR. Reading the AIC_FVR has effect of automatically clearing the fast interrupt, if it has been programmed to be edge triggered. In this case only, it de-asserts the nFIQ line on the processor.
4. The previous step enables branching to the corresponding interrupt service routine. It is not necessary to save the link register R14_fiq and SPSR_fiq if nested fast interrupts are not needed.
5. The Interrupt Handler can then proceed as required. It is not necessary to save registers R8 to R13 because FIQ mode has its own dedicated registers and the user R8 to R13 are banked. The other registers, R0 to R7, must be saved before being used, and restored at the end (before the next step). Note that if the fast interrupt is programmed to be level sensitive, the source of the interrupt must be cleared during this phase in order to de-assert the interrupt source 0.
6. Finally, the Link Register R14_fiq is restored into the PC after decrementing it by four (with instruction `SUB PC, LR, #4` for example). This has the effect of returning from the interrupt to whatever was being executed before, loading the CPSR with the SPSR and masking or unmasking the fast interrupt depending on the state saved in the SPSR.

Note: The “F” bit in SPSR is significant. If it is set, it indicates that the ARM core was just about to mask FIQ interrupts when the mask instruction was interrupted. Hence when the SPSR is restored, the interrupted instruction is completed (FIQ is masked).

Another way to handle the fast interrupt is to map the interrupt service routine at the address of the ARM vector 0x1C. This method does not use the vectoring, so that reading AIC_FVR must be performed at the very beginning of the handler operation. However, this method saves the execution of a branch instruction.

26.7.4.5 Fast Forcing

The Fast Forcing feature of the advanced interrupt controller provides redirection of any normal Interrupt source on the fast interrupt controller.

Fast Forcing is enabled or disabled by writing to the Fast Forcing Enable Register (AIC_FFER) and the Fast Forcing Disable Register (AIC_FFDR). Writing to these registers results in an update of the Fast Forcing Status Register (AIC_FFSR) that controls the feature for each internal or external interrupt source.

When Fast Forcing is disabled, the interrupt sources are handled as described in the previous pages.

When Fast Forcing is enabled, the edge/level programming and, in certain cases, edge detection of the interrupt source is still active but the source cannot trigger a normal interrupt to the processor and is not seen by the priority handler.

If the interrupt source is programmed in level-sensitive mode and an active level is sampled, Fast Forcing results in the assertion of the nFIQ line to the core.

If the interrupt source is programmed in edge-triggered mode and an active edge is detected, Fast Forcing results in the assertion of the nFIQ line to the core.

The Fast Forcing feature does not affect the Source 0 pending bit in the Interrupt Pending Register (AIC_IPR).

The FIQ Vector Register (AIC_FVR) reads the contents of the Source Vector Register 0 (AIC_SVR0), whatever the source of the fast interrupt may be. The read of the FVR does not clear the Source 0 when the fast forcing feature is used and the interrupt source should be cleared by writing to the Interrupt Clear Command Register (AIC_ICCR).

All enabled and pending interrupt sources that have the fast forcing feature enabled and that are programmed in edge-triggered mode must be cleared by writing to the Interrupt Clear Command Register. In doing so, they are cleared independently and thus lost interrupts are prevented.

The read of AIC_IVR does not clear the source that has the fast forcing feature enabled.

The source 0, reserved to the fast interrupt, continues operating normally and becomes one of the Fast Interrupt sources.

Figure 26-10. Fast Forcing

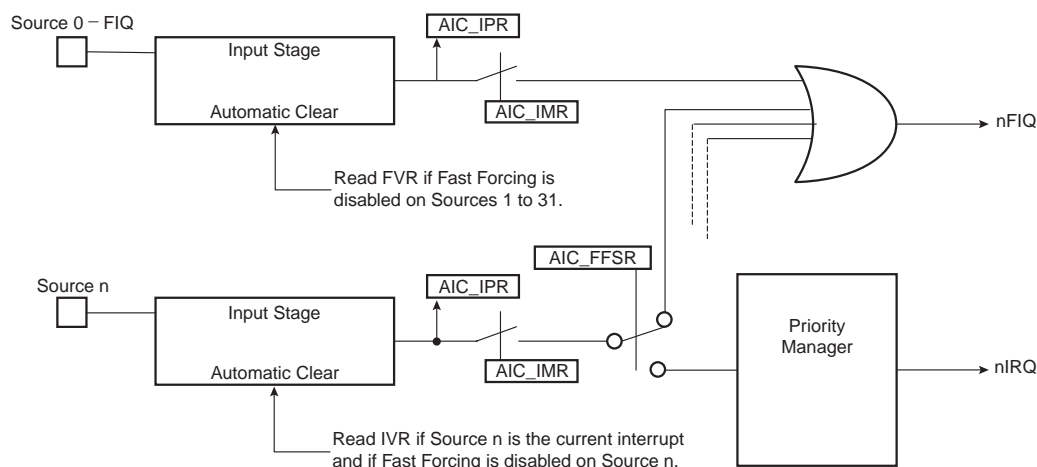

26.7.5 Protect Mode

The Protect Mode permits reading the Interrupt Vector Register without performing the associated automatic operations. This is necessary when working with a debug system. When a debugger, working either with a Debug Monitor or the ARM processor's ICE, stops the applications and updates the opened windows, it might read the AIC User Interface and thus the IVR. This has undesirable consequences:

- If an enabled interrupt with a higher priority than the current one is pending, it is stacked.
- If there is no enabled pending interrupt, the spurious vector is returned.

In either case, an End of Interrupt command is necessary to acknowledge and to restore the context of the AIC. This operation is generally not performed by the debug system as the debug system would become strongly intrusive and cause the application to enter an undesired state.

This is avoided by using the Protect Mode. Writing PROT in AIC_DCR (Debug Control Register) at 0x1 enables the Protect Mode.

When the Protect Mode is enabled, the AIC performs interrupt stacking only when a write access is performed on the AIC_IVR. Therefore, the Interrupt Service Routines must write (arbitrary data) to the AIC_IVR just after reading it. The new context of the AIC, including the value of the Interrupt Status Register (AIC_ISR), is updated with the current interrupt only when AIC_IVR is written.

An AIC_IVR read on its own (e.g., by a debugger), modifies neither the AIC context nor the AIC_ISR. Extra AIC_IVR reads perform the same operations. However, it is recommended to not stop the processor between the read and the write of AIC_IVR of the interrupt service routine to make sure the debugger does not modify the AIC context.

To summarize, in normal operating mode, the read of AIC_IVR performs the following operations within the AIC:

1. Calculates active interrupt (higher than current or spurious).
2. Determines and returns the vector of the active interrupt.
3. Memorizes the interrupt.
4. Pushes the current priority level onto the internal stack.
5. Acknowledges the interrupt.

However, while the Protect Mode is activated, only operations 1 to 3 are performed when AIC_IVR is read. Operations 4 and 5 are only performed by the AIC when AIC_IVR is written.

Software that has been written and debugged using the Protect Mode runs correctly in Normal Mode without modification. However, in Normal Mode the AIC_IVR write has no effect and can be removed to optimize the code.

26.7.6 Spurious Interrupt

The Advanced Interrupt Controller features protection against spurious interrupts. A spurious interrupt is defined as being the assertion of an interrupt source long enough for the AIC to assert the nIRQ, but no longer present when AIC_IVR is read. This is most prone to occur when:

- An external interrupt source is programmed in level-sensitive mode and an active level occurs for only a short time.
- An internal interrupt source is programmed in level sensitive and the output signal of the corresponding embedded peripheral is activated for a short time. (As in the case for the Watchdog.)
- An interrupt occurs just a few cycles before the software begins to mask it, thus resulting in a pulse on the interrupt source.

The AIC detects a spurious interrupt at the time the AIC_IVR is read while no enabled interrupt source is pending. When this happens, the AIC returns the value stored by the programmer in AIC_SPU (Spurious Vector Register). The programmer must store the address of a spurious interrupt handler in AIC_SPU as part of the application, to enable an as fast as possible return to the normal execution flow. This handler writes in AIC_EOICR and performs a return from interrupt.

26.7.7 General Interrupt Mask

The AIC features a General Interrupt Mask bit to prevent interrupts from reaching the processor. Both the nIRQ and the nFIQ lines are driven to their inactive state if the bit GMSK in AIC_DCR (Debug Control Register) is set. However, this mask does not prevent waking up the processor if it has entered Idle Mode. This function facilitates synchronizing the processor on a next event and, as soon as the event occurs, performs subsequent operations without having to handle an interrupt. It is strongly recommended to use this mask with caution.

26.8 Advanced Interrupt Controller (AIC) User Interface

26.8.1 Base Address

The AIC is mapped at the address 0xFFFF F000. It has a total 4-Kbyte addressing space. This permits the vectoring feature, as the PC-relative load/store instructions of the ARM processor support only a \pm 4-Kbyte offset.

Table 26-2. Register Mapping

| Offset | Register | Name | Access | Reset |
|-------------|---|-----------|------------|--------------------|
| 0x00 | Source Mode Register 0 | AIC_SMR0 | Read/Write | 0x0 |
| 0x04 | Source Mode Register 1 | AIC_SMR1 | Read/Write | 0x0 |
| ... | ... | ... | ... | ... |
| 0x7C | Source Mode Register 31 | AIC_SMR31 | Read/Write | 0x0 |
| 0x80 | Source Vector Register 0 | AIC_SVR0 | Read/Write | 0x0 |
| 0x84 | Source Vector Register 1 | AIC_SVR1 | Read/Write | 0x0 |
| ... | ... | ... | ... | ... |
| 0xFC | Source Vector Register 31 | AIC_SVR31 | Read/Write | 0x0 |
| 0x100 | Interrupt Vector Register | AIC_IVR | Read-only | 0x0 |
| 0x104 | FIQ Interrupt Vector Register | AIC_FVR | Read-only | 0x0 |
| 0x108 | Interrupt Status Register | AIC_ISR | Read-only | 0x0 |
| 0x10C | Interrupt Pending Register ⁽²⁾ | AIC_IPR | Read-only | 0x0 ⁽¹⁾ |
| 0x110 | Interrupt Mask Register ⁽²⁾ | AIC_IMR | Read-only | 0x0 |
| 0x114 | Core Interrupt Status Register | AIC_CISR | Read-only | 0x0 |
| 0x118–0x11C | Reserved | – | – | – |
| 0x120 | Interrupt Enable Command Register ⁽²⁾ | AIC_IECR | Write-only | – |
| 0x124 | Interrupt Disable Command Register ⁽²⁾ | AIC_IDCR | Write-only | – |
| 0x128 | Interrupt Clear Command Register ⁽²⁾ | AIC_ICCR | Write-only | – |
| 0x12C | Interrupt Set Command Register ⁽²⁾ | AIC_ISCR | Write-only | – |
| 0x130 | End of Interrupt Command Register | AIC_EOICR | Write-only | – |
| 0x134 | Spurious Interrupt Vector Register | AIC_SPU | Read/Write | 0x0 |
| 0x138 | Debug Control Register | AIC_DCR | Read/Write | 0x0 |
| 0x13C | Reserved | – | – | – |
| 0x140 | Fast Forcing Enable Register ⁽²⁾ | AIC_FFER | Write-only | – |
| 0x144 | Fast Forcing Disable Register ⁽²⁾ | AIC_FFDR | Write-only | – |
| 0x148 | Fast Forcing Status Register ⁽²⁾ | AIC_FFSR | Read-only | 0x0 |
| 0x14C–0x1E0 | Reserved | – | – | – |
| 0x1EC–0x1FC | Reserved | – | – | – |

- Notes:
1. The reset value of this register depends on the level of the external interrupt source. All other sources are cleared at reset, thus not pending.
 2. PID2...PID31 bit fields refer to the identifiers as defined in the Peripheral Identifiers section of the product datasheet.

26.8.2 AIC Source Mode Register

Name: AIC_SMR0..AIC_SMR31

Address: 0xFFFFF000

Access: Read/Write

| | | | | | | | |
|----|---------|----|----|----|-------|----|----|
| 31 | 30 | 29 | 28 | 27 | 26 | 25 | 24 |
| – | – | – | – | – | – | – | – |
| 23 | 22 | 21 | 20 | 19 | 18 | 17 | 16 |
| – | – | – | – | – | – | – | – |
| 15 | 14 | 13 | 12 | 11 | 10 | 9 | 8 |
| – | – | – | – | – | – | – | – |
| 7 | 6 | 5 | 4 | 3 | 2 | 1 | 0 |
| – | SRCTYPE | | – | – | PRIOR | | |

- **PRIOR: Priority Level**

Programs the priority level for all sources except FIQ source (source 0).

The priority level can be between 0 (lowest) and 7 (highest).

The priority level is not used for the FIQ in the related SMR register AIC_SMRx.

- **SRCTYPE: Interrupt Source Type**

The active level or edge is not programmable for the internal interrupt sources.

| Value | | Internal Interrupt Sources | External Interrupt Sources |
|-------|---|----------------------------|----------------------------|
| 0 | 0 | High level Sensitive | Low level Sensitive |
| 0 | 1 | Positive edge triggered | Negative edge triggered |
| 1 | 0 | High level Sensitive | High level Sensitive |
| 1 | 1 | Positive edge triggered | Positive edge triggered |

26.8.3 AIC Source Vector Register

Name: AIC_SVR0..AIC_SVR31

Address: 0xFFFFF080

Access: Read/Write

| | | | | | | | |
|--------|----|----|----|----|----|----|----|
| 31 | 30 | 29 | 28 | 27 | 26 | 25 | 24 |
| VECTOR | | | | | | | |
| 23 | 22 | 21 | 20 | 19 | 18 | 17 | 16 |
| VECTOR | | | | | | | |
| 15 | 14 | 13 | 12 | 11 | 10 | 9 | 8 |
| VECTOR | | | | | | | |
| 7 | 6 | 5 | 4 | 3 | 2 | 1 | 0 |
| VECTOR | | | | | | | |

- **VECTOR: Source Vector**

The user may store in these registers the addresses of the corresponding handler for each interrupt source.

26.8.4 AIC Interrupt Vector Register

Name: AIC_IVR

Address: 0xFFFFF100

Access: Read-only

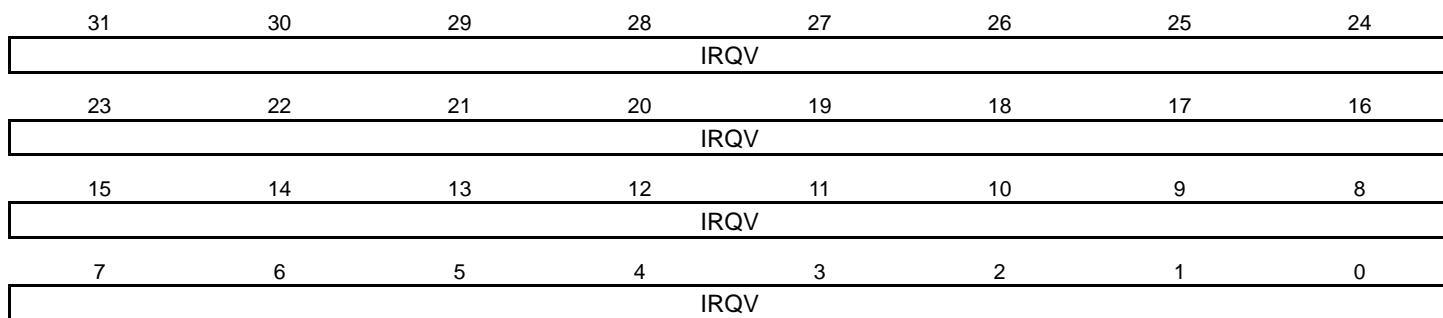

- **IRQV: Interrupt Vector Register**

The Interrupt Vector Register contains the vector programmed by the user in the Source Vector Register corresponding to the current interrupt.

The Source Vector Register is indexed using the current interrupt number when the Interrupt Vector Register is read.

When there is no current interrupt, the Interrupt Vector Register reads the value stored in AIC_SPU.

26.8.5 AIC FIQ Vector Register

Name: AIC_FVR

Address: 0xFFFFF104

Access: Read-only

| | | | | | | | |
|------|----|----|----|----|----|----|----|
| 31 | 30 | 29 | 28 | 27 | 26 | 25 | 24 |
| FIQV | | | | | | | |
| 23 | 22 | 21 | 20 | 19 | 18 | 17 | 16 |
| FIQV | | | | | | | |
| 15 | 14 | 13 | 12 | 11 | 10 | 9 | 8 |
| FIQV | | | | | | | |
| 7 | 6 | 5 | 4 | 3 | 2 | 1 | 0 |
| FIQV | | | | | | | |

- **FIQV: FIQ Vector Register**

The FIQ Vector Register contains the vector programmed by the user in the Source Vector Register 0. When there is no fast interrupt, the FIQ Vector Register reads the value stored in AIC_SPU.

26.8.6 AIC Interrupt Status Register

Name: AIC_ISR

Address: 0xFFFFF108

Access: Read-only

| | | | | | | | | |
|----|----|----|-------|----|----|----|----|--|
| 31 | 30 | 29 | 28 | 27 | 26 | 25 | 24 | |
| – | – | – | – | – | – | – | – | |
| 23 | 22 | 21 | 20 | 19 | 18 | 17 | 16 | |
| – | – | – | – | – | – | – | – | |
| 15 | 14 | 13 | 12 | 11 | 10 | 9 | 8 | |
| – | – | – | – | – | – | – | – | |
| 7 | 6 | 5 | 4 | 3 | 2 | 1 | 0 | |
| – | – | – | IRQID | | | | | |

- **IRQID: Current Interrupt Identifier**

The Interrupt Status Register returns the current interrupt source number.

26.8.7 AIC Interrupt Pending Register

Name: AIC_IPR

Address: 0xFFFFF10C

Access: Read-only

| | | | | | | | |
|-------|-------|-------|-------|-------|-------|-------|-------|
| 31 | 30 | 29 | 28 | 27 | 26 | 25 | 24 |
| PID31 | PID30 | PID29 | PID28 | PID27 | PID26 | PID25 | PID24 |
| 23 | 22 | 21 | 20 | 19 | 18 | 17 | 16 |
| PID23 | PID22 | PID21 | PID20 | PID19 | PID18 | PID17 | PID16 |
| 15 | 14 | 13 | 12 | 11 | 10 | 9 | 8 |
| PID15 | PID14 | PID13 | PID12 | PID11 | PID10 | PID9 | PID8 |
| 7 | 6 | 5 | 4 | 3 | 2 | 1 | 0 |
| PID7 | PID6 | PID5 | PID4 | PID3 | PID2 | SYS | FIQ |

- **FIQ, SYS, PID2-PID31: Interrupt Pending**

0: Corresponding interrupt is not pending.

1: Corresponding interrupt is pending.

26.8.8 AIC Interrupt Mask Register

Name: AIC_IMR

Address: 0xFFFFF110

Access: Read-only

| | | | | | | | |
|-------|-------|-------|-------|-------|-------|-------|-------|
| 31 | 30 | 29 | 28 | 27 | 26 | 25 | 24 |
| PID31 | PID30 | PID29 | PID28 | PID27 | PID26 | PID25 | PID24 |
| 23 | 22 | 21 | 20 | 19 | 18 | 17 | 16 |
| PID23 | PID22 | PID21 | PID20 | PID19 | PID18 | PID17 | PID16 |
| 15 | 14 | 13 | 12 | 11 | 10 | 9 | 8 |
| PID15 | PID14 | PID13 | PID12 | PID11 | PID10 | PID9 | PID8 |
| 7 | 6 | 5 | 4 | 3 | 2 | 1 | 0 |
| PID7 | PID6 | PID5 | PID4 | PID3 | PID2 | SYS | FIQ |

- **FIQ, SYS, PID2-PID31: Interrupt Mask**

0: Corresponding interrupt is disabled.

1: Corresponding interrupt is enabled.

26.8.9 AIC Core Interrupt Status Register

Name: AIC_CISR

Address: 0xFFFFF114

Access: Read-only

| | | | | | | | |
|----|----|----|----|----|----|------|------|
| 31 | 30 | 29 | 28 | 27 | 26 | 25 | 24 |
| – | – | – | – | – | – | – | – |
| 23 | 22 | 21 | 20 | 19 | 18 | 17 | 16 |
| – | – | – | – | – | – | – | – |
| 15 | 14 | 13 | 12 | 11 | 10 | 9 | 8 |
| – | – | – | – | – | – | – | – |
| 7 | 6 | 5 | 4 | 3 | 2 | 1 | 0 |
| – | – | – | – | – | – | NIRQ | NFIQ |

- **NFIQ: NFIQ Status**

0: nFIQ line is deactivated.

1: nFIQ line is active.

- **NIRQ: NIRQ Status**

0: nIRQ line is deactivated.

1: nIRQ line is active.

26.8.10 AIC Interrupt Enable Command Register

Name: AIC_IOCR

Address: 0xFFFFF120

Access: Write-only

| | | | | | | | |
|-------|-------|-------|-------|-------|-------|-------|-------|
| 31 | 30 | 29 | 28 | 27 | 26 | 25 | 24 |
| PID31 | PID30 | PID29 | PID28 | PID27 | PID26 | PID25 | PID24 |
| 23 | 22 | 21 | 20 | 19 | 18 | 17 | 16 |
| PID23 | PID22 | PID21 | PID20 | PID19 | PID18 | PID17 | PID16 |
| 15 | 14 | 13 | 12 | 11 | 10 | 9 | 8 |
| PID15 | PID14 | PID13 | PID12 | PID11 | PID10 | PID9 | PID8 |
| 7 | 6 | 5 | 4 | 3 | 2 | 1 | 0 |
| PID7 | PID6 | PID5 | PID4 | PID3 | PID2 | SYS | FIQ |

- **FIQ, SYS, PID2-PID31: Interrupt Enable**

0: No effect.

1: Enables corresponding interrupt.

26.8.11 AIC Interrupt Disable Command Register

Name: AIC_IDCR

Address: 0xFFFFF124

Access: Write-only

| | | | | | | | |
|-------|-------|-------|-------|-------|-------|-------|-------|
| 31 | 30 | 29 | 28 | 27 | 26 | 25 | 24 |
| PID31 | PID30 | PID29 | PID28 | PID27 | PID26 | PID25 | PID24 |
| 23 | 22 | 21 | 20 | 19 | 18 | 17 | 16 |
| PID23 | PID22 | PID21 | PID20 | PID19 | PID18 | PID17 | PID16 |
| 15 | 14 | 13 | 12 | 11 | 10 | 9 | 8 |
| PID15 | PID14 | PID13 | PID12 | PID11 | PID10 | PID9 | PID8 |
| 7 | 6 | 5 | 4 | 3 | 2 | 1 | 0 |
| PID7 | PID6 | PID5 | PID4 | PID3 | PID2 | SYS | FIQ |

- **FIQ, SYS, PID2-PID31: Interrupt Disable**

0: No effect.

1: Disables corresponding interrupt.

26.8.12 AIC Interrupt Clear Command Register

Name: AIC_ICCR

Address: 0xFFFFF128

Access: Write-only

| | | | | | | | |
|-------|-------|-------|-------|-------|-------|-------|-------|
| 31 | 30 | 29 | 28 | 27 | 26 | 25 | 24 |
| PID31 | PID30 | PID29 | PID28 | PID27 | PID26 | PID25 | PID24 |
| 23 | 22 | 21 | 20 | 19 | 18 | 17 | 16 |
| PID23 | PID22 | PID21 | PID20 | PID19 | PID18 | PID17 | PID16 |
| 15 | 14 | 13 | 12 | 11 | 10 | 9 | 8 |
| PID15 | PID14 | PID13 | PID12 | PID11 | PID10 | PID9 | PID8 |
| 7 | 6 | 5 | 4 | 3 | 2 | 1 | 0 |
| PID7 | PID6 | PID5 | PID4 | PID3 | PID2 | SYS | FIQ |

- **FIQ, SYS, PID2-PID31: Interrupt Clear**

0: No effect.

1: Clears corresponding interrupt.

26.8.13 AIC Interrupt Set Command Register

Name: AIC_ISCR

Address: 0xFFFFF12C

Access: Write-only

| | | | | | | | |
|-------|-------|-------|-------|-------|-------|-------|-------|
| 31 | 30 | 29 | 28 | 27 | 26 | 25 | 24 |
| PID31 | PID30 | PID29 | PID28 | PID27 | PID26 | PID25 | PID24 |
| 23 | 22 | 21 | 20 | 19 | 18 | 17 | 16 |
| PID23 | PID22 | PID21 | PID20 | PID19 | PID18 | PID17 | PID16 |
| 15 | 14 | 13 | 12 | 11 | 10 | 9 | 8 |
| PID15 | PID14 | PID13 | PID12 | PID11 | PID10 | PID9 | PID8 |
| 7 | 6 | 5 | 4 | 3 | 2 | 1 | 0 |
| PID7 | PID6 | PID5 | PID4 | PID3 | PID2 | SYS | FIQ |

- **FIQ, SYS, PID2-PID31: Interrupt Set**

0: No effect.

1: Sets corresponding interrupt.

26.8.14 AIC End of Interrupt Command Register

Name: AIC_EOICR
Address: 0xFFFFF130
Access: Write-only

| | | | | | | | |
|----|----|----|----|----|----|----|----|
| 31 | 30 | 29 | 28 | 27 | 26 | 25 | 24 |
| – | – | – | – | – | – | – | – |
| 23 | 22 | 21 | 20 | 19 | 18 | 17 | 16 |
| – | – | – | – | – | – | – | – |
| 15 | 14 | 13 | 12 | 11 | 10 | 9 | 8 |
| – | – | – | – | – | – | – | – |
| 7 | 6 | 5 | 4 | 3 | 2 | 1 | 0 |
| – | – | – | – | – | – | – | – |

The End of Interrupt Command Register is used by the interrupt routine to indicate that the interrupt treatment is complete. Any value can be written because it is only necessary to make a write to this register location to signal the end of interrupt treatment.

26.8.15 AIC Spurious Interrupt Vector Register

Name: AIC_SPU

Address: 0xFFFFF134

Access: Read/Write

| | | | | | | | |
|------|----|----|----|----|----|----|----|
| 31 | 30 | 29 | 28 | 27 | 26 | 25 | 24 |
| SIVR | | | | | | | |
| 23 | 22 | 21 | 20 | 19 | 18 | 17 | 16 |
| SIVR | | | | | | | |
| 15 | 14 | 13 | 12 | 11 | 10 | 9 | 8 |
| SIVR | | | | | | | |
| 7 | 6 | 5 | 4 | 3 | 2 | 1 | 0 |
| SIVR | | | | | | | |

- **SIVR: Spurious Interrupt Vector Register**

The user may store the address of a spurious interrupt handler in this register. The written value is returned in AIC_IVR in case of a spurious interrupt and in AIC_FVR in case of a spurious fast interrupt.

26.8.16 AIC Debug Control Register

Name: AIC_DCR

Address: 0xFFFFF138

Access: Read/Write

| | | | | | | | |
|----|----|----|----|----|----|------|------|
| 31 | 30 | 29 | 28 | 27 | 26 | 25 | 24 |
| – | – | – | – | – | – | – | – |
| 23 | 22 | 21 | 20 | 19 | 18 | 17 | 16 |
| – | – | – | – | – | – | – | – |
| 15 | 14 | 13 | 12 | 11 | 10 | 9 | 8 |
| – | – | – | – | – | – | – | – |
| 7 | 6 | 5 | 4 | 3 | 2 | 1 | 0 |
| – | – | – | – | – | – | GMSK | PROT |

- **PROT: Protection Mode**

0: The Protection Mode is disabled.

1: The Protection Mode is enabled.

- **GMSK: General Mask**

0: The nIRQ and nFIQ lines are normally controlled by the AIC.

1: The nIRQ and nFIQ lines are tied to their inactive state.

26.8.17 AIC Fast Forcing Enable Register

Name: AIC_FFER

Address: 0xFFFFF140

Access: Write-only

| | | | | | | | |
|-------|-------|-------|-------|-------|-------|-------|-------|
| 31 | 30 | 29 | 28 | 27 | 26 | 25 | 24 |
| PID31 | PID30 | PID29 | PID28 | PID27 | PID26 | PID25 | PID24 |
| 23 | 22 | 21 | 20 | 19 | 18 | 17 | 16 |
| PID23 | PID22 | PID21 | PID20 | PID19 | PID18 | PID17 | PID16 |
| 15 | 14 | 13 | 12 | 11 | 10 | 9 | 8 |
| PID15 | PID14 | PID13 | PID12 | PID11 | PID10 | PID9 | PID8 |
| 7 | 6 | 5 | 4 | 3 | 2 | 1 | 0 |
| PID7 | PID6 | PID5 | PID4 | PID3 | PID2 | SYS | – |

- **SYS, PID2-PID31: Fast Forcing Enable**

0: No effect.

1: Enables the fast forcing feature on the corresponding interrupt.

26.8.18 AIC Fast Forcing Disable Register

Name: AIC_FFDR

Address: 0xFFFFF144

Access: Write-only

| | | | | | | | |
|-------|-------|-------|-------|-------|-------|-------|-------|
| 31 | 30 | 29 | 28 | 27 | 26 | 25 | 24 |
| PID31 | PID30 | PID29 | PID28 | PID27 | PID26 | PID25 | PID24 |
| 23 | 22 | 21 | 20 | 19 | 18 | 17 | 16 |
| PID23 | PID22 | PID21 | PID20 | PID19 | PID18 | PID17 | PID16 |
| 15 | 14 | 13 | 12 | 11 | 10 | 9 | 8 |
| PID15 | PID14 | PID13 | PID12 | PID11 | PID10 | PID9 | PID8 |
| 7 | 6 | 5 | 4 | 3 | 2 | 1 | 0 |
| PID7 | PID6 | PID5 | PID4 | PID3 | PID2 | SYS | – |

- **SYS, PID2-PID31: Fast Forcing Disable**

0: No effect.

1: Disables the Fast Forcing feature on the corresponding interrupt.

26.8.19 AIC Fast Forcing Status Register

Name: AIC_FFSR

Address: 0xFFFFF148

Access: Read-only

| | | | | | | | |
|-------|-------|-------|-------|-------|-------|-------|-------|
| 31 | 30 | 29 | 28 | 27 | 26 | 25 | 24 |
| PID31 | PID30 | PID29 | PID28 | PID27 | PID26 | PID25 | PID24 |
| 23 | 22 | 21 | 20 | 19 | 18 | 17 | 16 |
| PID23 | PID22 | PID21 | PID20 | PID19 | PID18 | PID17 | PID16 |
| 15 | 14 | 13 | 12 | 11 | 10 | 9 | 8 |
| PID15 | PID14 | PID13 | PID12 | PID11 | PID10 | PID9 | PID8 |
| 7 | 6 | 5 | 4 | 3 | 2 | 1 | 0 |
| PID7 | PID6 | PID5 | PID4 | PID3 | PID2 | SYS | – |

- **SYS, PID2-PID31: Fast Forcing Status**

0: The Fast Forcing feature is disabled on the corresponding interrupt.

1: The Fast Forcing feature is enabled on the corresponding interrupt.

27. Debug Unit (DBGU)

27.1 Overview

The Debug Unit provides a single entry point from the processor for access to all the debug capabilities of Atmel's ARM-based systems.

The Debug Unit features a two-pin UART that can be used for several debug and trace purposes and offers an ideal medium for in-situ programming solutions and debug monitor communications. The Debug Unit two-pin UART can be used stand-alone for general purpose serial communication. Moreover, the association with two peripheral data controller channels permits packet handling for these tasks with processor time reduced to a minimum.

The Debug Unit also makes the Debug Communication Channel (DCC) signals provided by the In-circuit Emulator of the ARM processor visible to the software. These signals indicate the status of the DCC read and write registers and generate an interrupt to the ARM processor, making possible the handling of the DCC under interrupt control.

Chip Identifier registers permit recognition of the device and its revision. These registers inform as to the sizes and types of the on-chip memories, as well as the set of embedded peripherals.

Finally, the Debug Unit features a Force NTRST capability that enables the software to decide whether to prevent access to the system via the In-circuit Emulator. This permits protection of the code, stored in ROM.

27.2 Embedded Characteristics

- Composed of four functions
 - Two-pin UART
 - Debug Communication Channel (DCC) support
 - Chip ID Registers
 - ICE Access Prevention
- Two-pin UART
 - Implemented features are 100% compatible with the standard Atmel USART
 - Independent receiver and transmitter with a common programmable Baud Rate Generator
 - Even, Odd, Mark or Space Parity Generation
 - Parity, Framing and Overrun Error Detection
 - Automatic Echo, Local Loopback and Remote Loopback Channel Modes
 - Support for two PDC channels with connection to receiver and transmitter
- Debug Communication Channel Support
 - Offers visibility of COMMRX and COMMTX signals from the ARM Processor
- Chip ID Registers
 - Identification of the device revision, sizes of the embedded memories, set of peripherals
- ICE Access prevention
 - Enables software to prevent system access through the ARM Processor's ICE
 - Prevention is made by asserting the NTRST line of the ARM Processor's ICE

27.3 Block Diagram

Figure 27-1. Debug Unit Functional Block Diagram

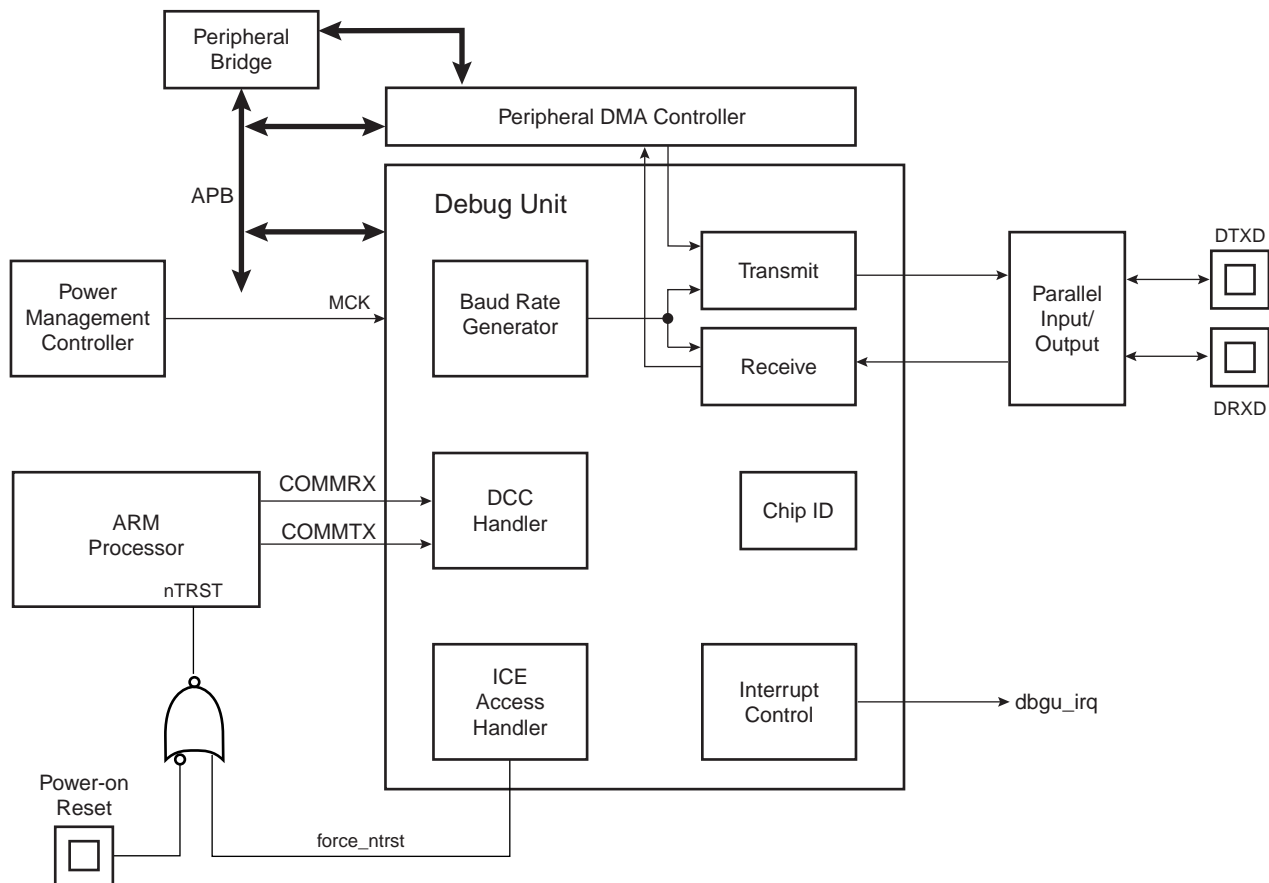
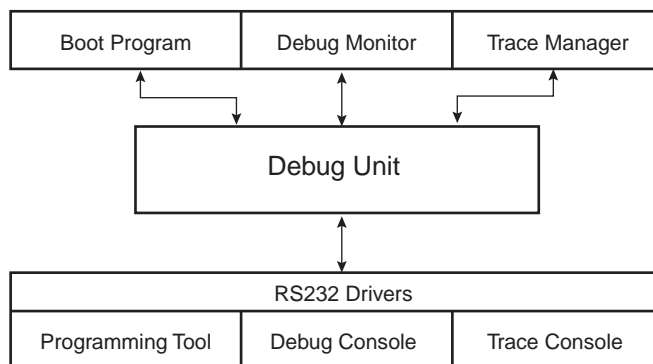

Table 27-1. Debug Unit Pin Description

| Pin Name | Description | Type |
|----------|---------------------|--------|
| DRXD | Debug Receive Data | Input |
| DTXD | Debug Transmit Data | Output |

Figure 27-2. Debug Unit Application Example



27.4 Product Dependencies

27.4.1 I/O Lines

Depending on product integration, the Debug Unit pins may be multiplexed with PIO lines. In this case, the programmer must first configure the corresponding PIO Controller to enable I/O lines operations of the Debug Unit.

27.4.2 Power Management

Depending on product integration, the Debug Unit clock may be controllable through the Power Management Controller. In this case, the programmer must first configure the PMC to enable the Debug Unit clock. Usually, the peripheral identifier used for this purpose is 1.

27.4.3 Interrupt Source

Depending on product integration, the Debug Unit interrupt line is connected to one of the interrupt sources of the Advanced Interrupt Controller. Interrupt handling requires programming of the AIC before configuring the Debug Unit. Usually, the Debug Unit interrupt line connects to the interrupt source 1 of the AIC, which may be shared with the real-time clock, the system timer interrupt lines and other system peripheral interrupts, as shown in [Figure 27-1](#). This sharing requires the programmer to determine the source of the interrupt when the source 1 is triggered.

27.5 UART Operations

The Debug Unit operates as a UART, (asynchronous mode only) and supports only 8-bit character handling (with parity). It has no clock pin.

The Debug Unit's UART is made up of a receiver and a transmitter that operate independently, and a common baud rate generator. Receiver timeout and transmitter time guard are not implemented. However, all the implemented features are compatible with those of a standard USART.

27.5.1 Baud Rate Generator

The baud rate generator provides the bit period clock named baud rate clock to both the receiver and the transmitter.

The baud rate clock is the master clock divided by 16 times the value (CD) written in DBGU_BRGR (Baud Rate Generator Register). If DBGU_BRGR is set to 0, the baud rate clock is disabled and the Debug Unit's UART remains inactive. The maximum allowable baud rate is Master Clock divided by 16. The minimum allowable baud rate is Master Clock divided by (16 x 65536).

$$\text{Baud Rate} = \frac{\text{MCK}}{16 \times \text{CD}}$$

Figure 27-3. Baud Rate Generator

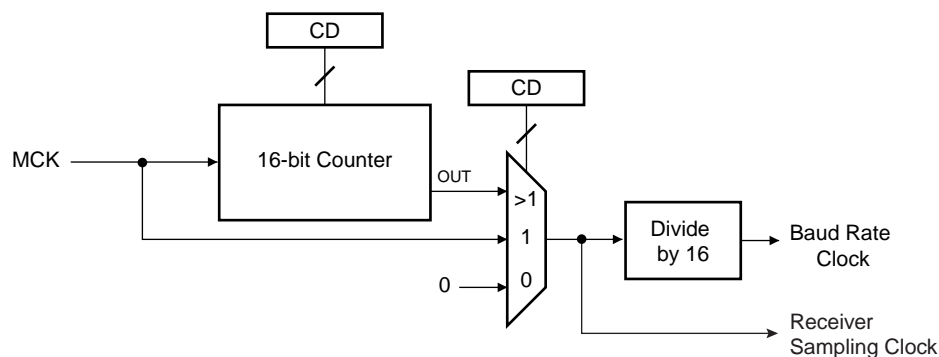

27.5.2 Receiver

27.5.2.1 Receiver Reset, Enable and Disable

After device reset, the Debug Unit receiver is disabled and must be enabled before being used. The receiver can be enabled by writing the control register `DBGU_CR` with the bit `RXEN` at 1. At this command, the receiver starts looking for a start bit.

The programmer can disable the receiver by writing `DBGU_CR` with the bit `RXDIS` at 1. If the receiver is waiting for a start bit, it is immediately stopped. However, if the receiver has already detected a start bit and is receiving the data, it waits for the stop bit before actually stopping its operation.

The programmer can also put the receiver in its reset state by writing `DBGU_CR` with the bit `RSTRX` at 1. In doing so, the receiver immediately stops its current operations and is disabled, whatever its current state. If `RSTRX` is applied when data is being processed, this data is lost.

27.5.2.2 Start Detection and Data Sampling

The Debug Unit only supports asynchronous operations, and this affects only its receiver. The Debug Unit receiver detects the start of a received character by sampling the `DRXD` signal until it detects a valid start bit. A low level (space) on `DRXD` is interpreted as a valid start bit if it is detected for more than 7 cycles of the sampling clock, which is 16 times the baud rate. Hence, a space that is longer than $7/16$ of the bit period is detected as a valid start bit. A space which is $7/16$ of a bit period or shorter is ignored and the receiver continues to wait for a valid start bit.

When a valid start bit has been detected, the receiver samples the `DRXD` at the theoretical midpoint of each bit. It is assumed that each bit lasts 16 cycles of the sampling clock (1-bit period) so the bit sampling point is eight cycles (0.5-bit period) after the start of the bit. The first sampling point is therefore 24 cycles (1.5-bit periods) after the falling edge of the start bit was detected.

Each subsequent bit is sampled 16 cycles (1-bit period) after the previous one.

Figure 27-4. Start Bit Detection

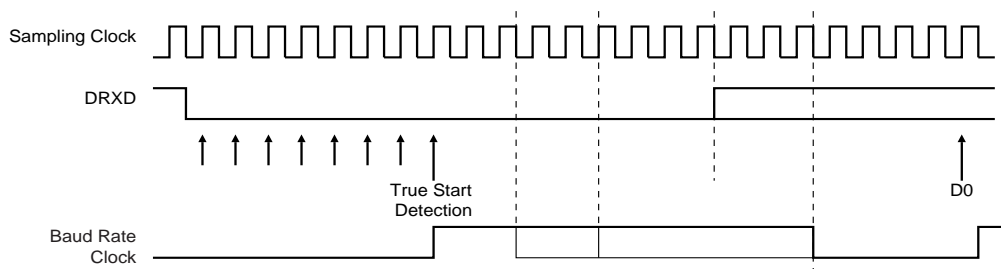
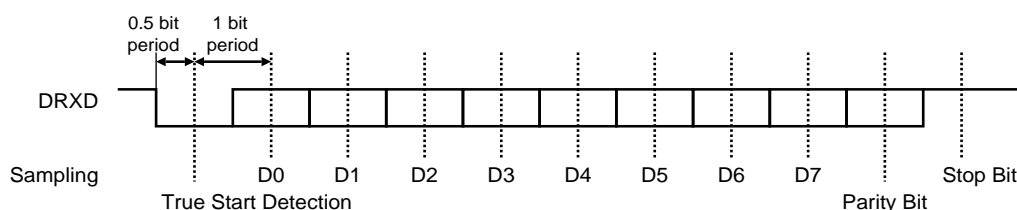

Figure 27-5. Character Reception

Example: 8-bit, parity enabled 1 stop



27.5.2.3 Receiver Ready

When a complete character is received, it is transferred to the `DBGU_RHR` and the `RXRDY` status bit in `DBGU_SR` (Status Register) is set. The bit `RXRDY` is automatically cleared when the receive holding register `DBGU_RHR` is read.

Figure 27-6. Receiver Ready

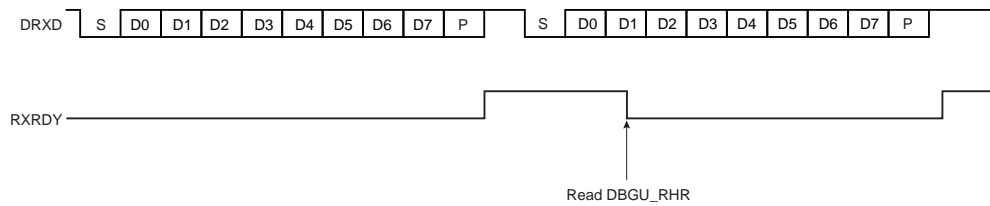

27.5.2.4 Receiver Overrun

If DBGU_RHR has not been read by the software (or the Peripheral Data Controller) since the last transfer, the RXRDY bit is still set and a new character is received, the OVRE status bit in DBGU_SR is set. OVRE is cleared when the software writes the control register DBGU_CR with the bit RSTSTA (Reset Status) at 1.

Figure 27-7. Receiver Overrun

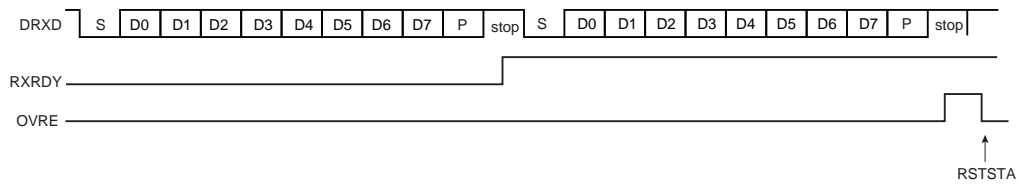

27.5.2.5 Parity Error

Each time a character is received, the receiver calculates the parity of the received data bits, in accordance with the field PAR in DBGU_MR. It then compares the result with the received parity bit. If different, the parity error bit PARE in DBGU_SR is set at the same time the RXRDY is set. The parity bit is cleared when the control register DBGU_CR is written with the bit RSTSTA (Reset Status) at 1. If a new character is received before the reset status command is written, the PARE bit remains at 1.

Figure 27-8. Parity Error

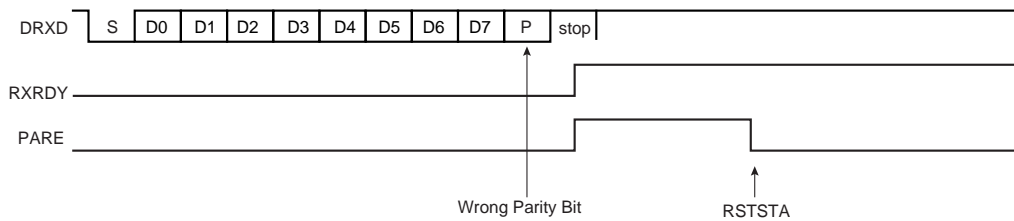

27.5.2.6 Receiver Framing Error

When a start bit is detected, it generates a character reception when all the data bits have been sampled. The stop bit is also sampled and when it is detected at 0, the FRAME (Framing Error) bit in DBGU_SR is set at the same time the RXRDY bit is set. The bit FRAME remains high until the control register DBGU_CR is written with the bit RSTSTA at 1.

Figure 27-9. Receiver Framing Error

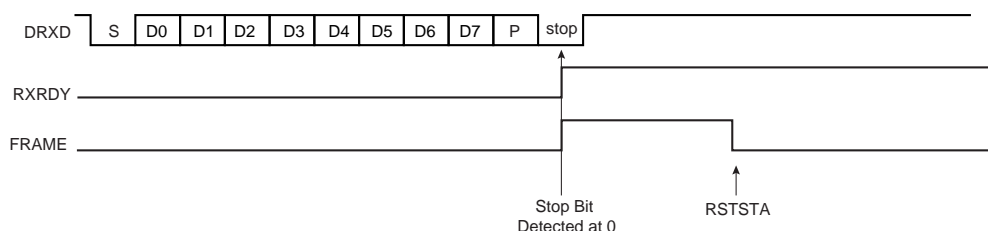

27.5.3 Transmitter

27.5.3.1 Transmitter Reset, Enable and Disable

After device reset, the Debug Unit transmitter is disabled and it must be enabled before being used. The transmitter is enabled by writing the control register `DBGU_CR` with the bit `TXEN` at 1. From this command, the transmitter waits for a character to be written in the Transmit Holding Register `DBGU_THR` before actually starting the transmission.

The programmer can disable the transmitter by writing `DBGU_CR` with the bit `TXDIS` at 1. If the transmitter is not operating, it is immediately stopped. However, if a character is being processed into the Shift Register and/or a character has been written in the Transmit Holding Register, the characters are completed before the transmitter is actually stopped.

The programmer can also put the transmitter in its reset state by writing the `DBGU_CR` with the bit `RSTTX` at 1. This immediately stops the transmitter, whether or not it is processing characters.

27.5.3.2 Transmit Format

The Debug Unit transmitter drives the pin `DTXD` at the baud rate clock speed. The line is driven depending on the format defined in the Mode Register and the data stored in the Shift Register. One start bit at level 0, then the 8 data bits, from the lowest to the highest bit, one optional parity bit and one stop bit at 1 are consecutively shifted out as shown on the following figure. The field `PARE` in the mode register `DBGU_MR` defines whether or not a parity bit is shifted out. When a parity bit is enabled, it can be selected between an odd parity, an even parity, or a fixed space or mark bit.

Figure 27-10. Character Transmission

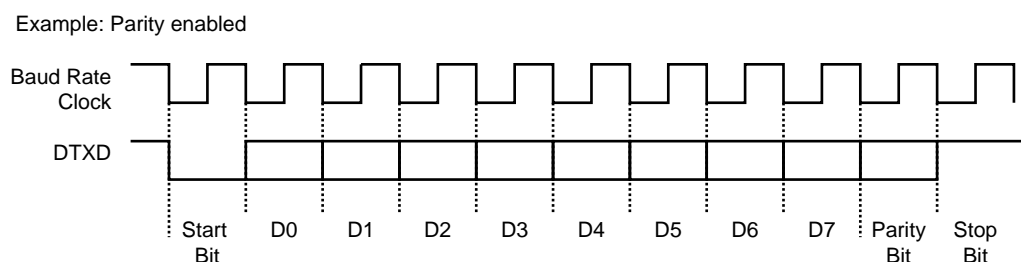

27.5.3.3 Transmitter Control

When the transmitter is enabled, the bit `TXRDY` (Transmitter Ready) is set in the status register `DBGU_SR`. The transmission starts when the programmer writes in the Transmit Holding Register `DBGU_THR`, and after the written character is transferred from `DBGU_THR` to the Shift Register. The bit `TXRDY` remains high until a second character is written in `DBGU_THR`. As soon as the first character is completed, the last character written in `DBGU_THR` is transferred into the shift register and `TXRDY` rises again, showing that the holding register is empty.

When both the Shift Register and the `DBGU_THR` are empty, i.e., all the characters written in `DBGU_THR` have been processed, the bit `TXEMPTY` rises after the last stop bit has been completed.

Figure 27-11. Transmitter Control

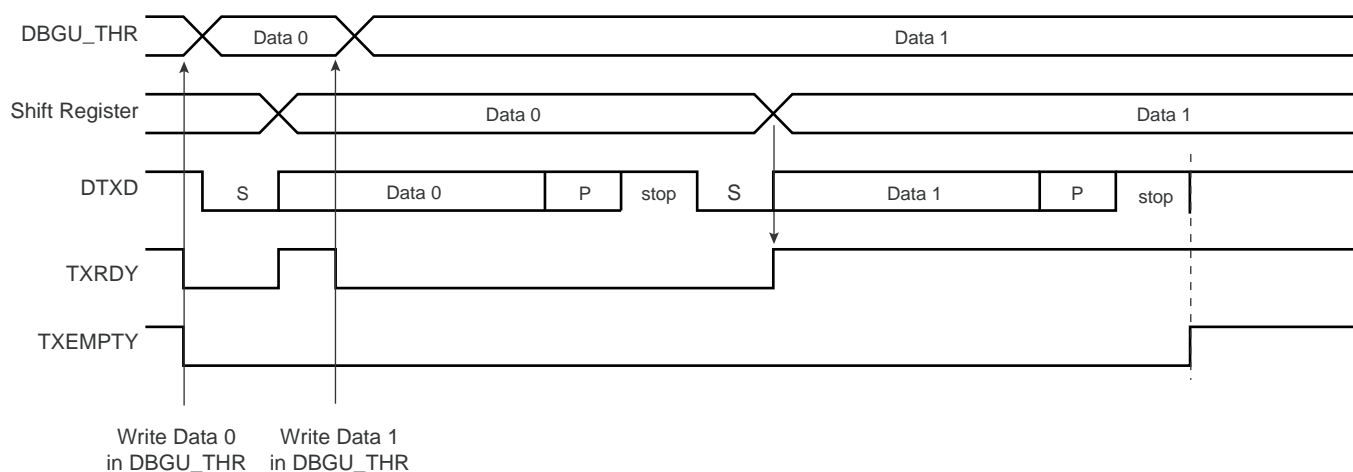

27.5.4 Peripheral Data Controller

Both the receiver and the transmitter of the Debug Unit's UART are generally connected to a Peripheral Data Controller (PDC) channel.

The peripheral data controller channels are programmed via registers that are mapped within the Debug Unit user interface from the offset 0x100. The status bits are reported in the Debug Unit status register DBGU_SR and can generate an interrupt.

The RXRDY bit triggers the PDC channel data transfer of the receiver. This results in a read of the data in DBGU_RHR. The TXRDY bit triggers the PDC channel data transfer of the transmitter. This results in a write of a data in DBGU_THR.

27.5.5 Test Modes

The Debug Unit supports three test modes. These modes of operation are programmed by using the field CHMODE (Channel Mode) in the mode register DBGU_MR.

The Automatic Echo mode allows bit-by-bit retransmission. When a bit is received on the DRXD line, it is sent to the DTXD line. The transmitter operates normally, but has no effect on the DTXD line.

The Local Loopback mode allows the transmitted characters to be received. DTXD and DRXD pins are not used and the output of the transmitter is internally connected to the input of the receiver. The DRXD pin level has no effect and the DTXD line is held high, as in idle state.

The Remote Loopback mode directly connects the DRXD pin to the DTXD line. The transmitter and the receiver are disabled and have no effect. This mode allows a bit-by-bit retransmission.

Figure 27-12. Test Modes

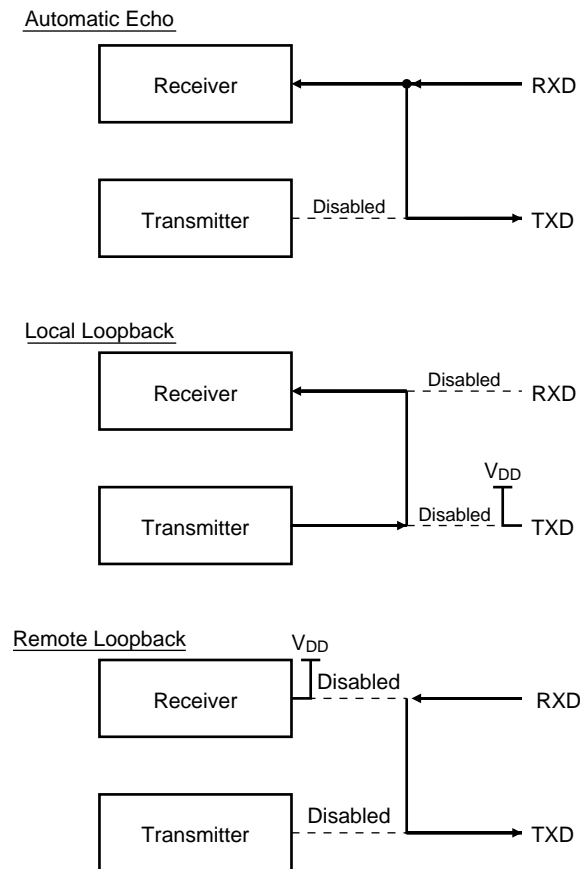

27.5.6 Debug Communication Channel Support

The Debug Unit handles the signals COMMRX and COMMTX that come from the Debug Communication Channel of the ARM Processor and are driven by the In-circuit Emulator.

The Debug Communication Channel contains two registers that are accessible through the ICE Breaker on the JTAG side and through the coprocessor 0 on the ARM Processor side.

As a reminder, the following instructions are used to read and write the Debug Communication Channel:

```
MRC                                p14, 0, Rd, c1, c0, 0
```

Returns the debug communication data read register into Rd

```
MCR                                p14, 0, Rd, c1, c0, 0
```

Writes the value in Rd to the debug communication data write register.

The bits COMMRX and COMMTX, which indicate, respectively, that the read register has been written by the debugger but not yet read by the processor, and that the write register has been written by the processor and not yet read by the debugger, are wired on the two highest bits of the status register DBGU_SR. These bits can generate an interrupt. This feature permits handling under interrupt a debug link between a debug monitor running on the target system and a debugger.

27.5.7 Chip Identifier

The Debug Unit features two chip identifier registers, DBGU_CIDR (Chip ID Register) and DBGU_EXID (Extension ID). Both registers contain a hard-wired value that is read-only. The first register contains the following fields:

- EXT - shows the use of the extension identifier register
- NVPTYP and NVPSIZ - identifies the type of embedded non-volatile memory and its size
- ARCH - identifies the set of embedded peripherals
- SRAMSIZ - indicates the size of the embedded SRAM
- EPROC - indicates the embedded ARM processor
- VERSION - gives the revision of the silicon

The second register is device-dependent and reads 0 if the bit EXT is 0.

27.5.8 ICE Access Prevention

The Debug Unit allows blockage of access to the system through the ARM processor's ICE interface. This feature is implemented via the register Force NTRST (DBGU_FNR), that allows assertion of the NTRST signal of the ICE Interface. Writing the bit FNTRST (Force NTRST) to 1 in this register prevents any activity on the TAP controller.

On standard devices, the bit FNTRST resets to 0 and thus does not prevent ICE access.

This feature is especially useful on custom ROM devices for customers who do not want their on-chip code to be visible.

27.6 Debug Unit (DBGU) User Interface

Table 27-2. Register Mapping

| Offset | Register | Name | Access | Reset |
|---------------|------------------------------|-----------|------------|------------|
| 0x0000 | Control Register | DBGU_CR | Write-only | – |
| 0x0004 | Mode Register | DBGU_MR | Read/Write | 0x0 |
| 0x0008 | Interrupt Enable Register | DBGU_IER | Write-only | – |
| 0x000C | Interrupt Disable Register | DBGU_IDR | Write-only | – |
| 0x0010 | Interrupt Mask Register | DBGU_IMR | Read-only | 0x0 |
| 0x0014 | Status Register | DBGU_SR | Read-only | 0x00181800 |
| 0x0018 | Receive Holding Register | DBGU_RHR | Read-only | 0x0 |
| 0x001C | Transmit Holding Register | DBGU_THR | Write-only | – |
| 0x0020 | Baud Rate Generator Register | DBGU_BRGR | Read/Write | 0x0 |
| 0x0024–0x003C | Reserved | – | – | – |
| 0x0040 | Chip ID Register | DBGU_CIDR | Read-only | 0x019703A0 |
| 0x0044 | Chip ID Extension Register | DBGU_EXID | Read-only | – |
| 0x0048 | Force NTRST Register | DBGU_FNR | Read/Write | 0x0 |
| 0x004C–0x00FC | Reserved | – | – | – |
| 0x0100–0x0124 | PDC Area | – | – | – |

27.6.1 Debug Unit Control Register

Name: DBGU_CR
Address: 0xFFFFF200
Access: Write-only

| | | | | | | | |
|-------|------|-------|------|-------|-------|----|--------|
| 31 | 30 | 29 | 28 | 27 | 26 | 25 | 24 |
| – | – | – | – | – | – | – | – |
| 23 | 22 | 21 | 20 | 19 | 18 | 17 | 16 |
| – | – | – | – | – | – | – | – |
| 15 | 14 | 13 | 12 | 11 | 10 | 9 | 8 |
| – | – | – | – | – | – | – | RSTSTA |
| 7 | 6 | 5 | 4 | 3 | 2 | 1 | 0 |
| TXDIS | TXEN | RXDIS | RXEN | RSTTX | RSTRX | – | – |

- **RSTRX: Reset Receiver**

0: No effect.

1: The receiver logic is reset and disabled. If a character is being received, the reception is aborted.

- **RSTTX: Reset Transmitter**

0: No effect.

1: The transmitter logic is reset and disabled. If a character is being transmitted, the transmission is aborted.

- **RXEN: Receiver Enable**

0: No effect.

1: The receiver is enabled if RXDIS is 0.

- **RXDIS: Receiver Disable**

0: No effect.

1: The receiver is disabled. If a character is being processed and RSTRX is not set, the character is completed before the receiver is stopped.

- **TXEN: Transmitter Enable**

0: No effect.

1: The transmitter is enabled if TXDIS is 0.

- **TXDIS: Transmitter Disable**

0: No effect.

1: The transmitter is disabled. If a character is being processed and a character has been written the DBGU_THR and RSTTX is not set, both characters are completed before the transmitter is stopped.

- **RSTSTA: Reset Status Bits**

0: No effect.

1: Resets the status bits PARE, FRAME and OVRE in the DBGU_SR.

27.6.2 Debug Unit Mode Register

Name: DBGU_MR
Address: 0xFFFFF204
Access: Read/Write

| | | | | | | | |
|--------|----|----|----|-----|----|----|----|
| 31 | 30 | 29 | 28 | 27 | 26 | 25 | 24 |
| – | – | – | – | – | – | – | – |
| 23 | 22 | 21 | 20 | 19 | 18 | 17 | 16 |
| – | – | – | – | – | – | – | – |
| 15 | 14 | 13 | 12 | 11 | 10 | 9 | 8 |
| CHMODE | | – | – | PAR | | – | |
| 7 | 6 | 5 | 4 | 3 | 2 | 1 | 0 |
| – | – | – | – | – | – | – | – |

• PAR: Parity Type

| Value | | | Parity Type |
|-------|---|---|---------------------------|
| 0 | 0 | 0 | Even parity |
| 0 | 0 | 1 | Odd parity |
| 0 | 1 | 0 | Space: parity forced to 0 |
| 0 | 1 | 1 | Mark: parity forced to 1 |
| 1 | x | x | No parity |

• CHMODE: Channel Mode

| Value | | Mode Description |
|-------|---|------------------|
| 0 | 0 | Normal Mode |
| 0 | 1 | Automatic Echo |
| 1 | 0 | Local Loopback |
| 1 | 1 | Remote Loopback |

27.6.3 Debug Unit Interrupt Enable Register

Name: DBGU_IER

Address: 0xFFFFF208

Access: Write-only

| | | | | | | | |
|--------|--------|------|--------|--------|----|---------|-------|
| 31 | 30 | 29 | 28 | 27 | 26 | 25 | 24 |
| COMMRX | COMMTX | – | – | – | – | – | – |
| 23 | 22 | 21 | 20 | 19 | 18 | 17 | 16 |
| – | – | – | – | – | – | – | – |
| 15 | 14 | 13 | 12 | 11 | 10 | 9 | 8 |
| – | – | – | RXBUFF | TXBUFE | – | TXEMPTY | – |
| 7 | 6 | 5 | 4 | 3 | 2 | 1 | 0 |
| PARE | FRAME | OVRE | ENDTX | ENDRX | – | TXRDY | RXRDY |

- **RXRDY: Enable RXRDY Interrupt**
- **TXRDY: Enable TXRDY Interrupt**
- **ENDRX: Enable End of Receive Transfer Interrupt**
- **ENDTX: Enable End of Transmit Interrupt**
- **OVRE: Enable Overrun Error Interrupt**
- **FRAME: Enable Framing Error Interrupt**
- **PARE: Enable Parity Error Interrupt**
- **TXEMPTY: Enable TXEMPTY Interrupt**
- **TXBUFE: Enable Buffer Empty Interrupt**
- **RXBUFF: Enable Buffer Full Interrupt**
- **COMMTX: Enable COMMTX (from ARM) Interrupt**
- **COMMRX: Enable COMMRX (from ARM) Interrupt**

0: No effect.

1: Enables the corresponding interrupt.

27.6.4 Debug Unit Interrupt Disable Register

Name: DBGU_IDR

Address: 0xFFFFF20C

Access: Write-only

| | | | | | | | |
|--------|--------|------|--------|--------|----|---------|-------|
| 31 | 30 | 29 | 28 | 27 | 26 | 25 | 24 |
| COMMRX | COMMTX | – | – | – | – | – | – |
| 23 | 22 | 21 | 20 | 19 | 18 | 17 | 16 |
| – | – | – | – | – | – | – | – |
| 15 | 14 | 13 | 12 | 11 | 10 | 9 | 8 |
| – | – | – | RXBUFF | TXBUFE | – | TXEMPTY | – |
| 7 | 6 | 5 | 4 | 3 | 2 | 1 | 0 |
| PARE | FRAME | OVRE | ENDTX | ENDRX | – | TXRDY | RXRDY |

- **RXRDY: Disable RXRDY Interrupt**
- **TXRDY: Disable TXRDY Interrupt**
- **ENDRX: Disable End of Receive Transfer Interrupt**
- **ENDTX: Disable End of Transmit Interrupt**
- **OVRE: Disable Overrun Error Interrupt**
- **FRAME: Disable Framing Error Interrupt**
- **PARE: Disable Parity Error Interrupt**
- **TXEMPTY: Disable TXEMPTY Interrupt**
- **TXBUFE: Disable Buffer Empty Interrupt**
- **RXBUFF: Disable Buffer Full Interrupt**
- **COMMTX: Disable COMMTX (from ARM) Interrupt**
- **COMMRX: Disable COMMRX (from ARM) Interrupt**

0: No effect.

1: Disables the corresponding interrupt.

27.6.5 Debug Unit Interrupt Mask Register

Name: DBGU_IMR

Address: 0xFFFFF210

Access: Read-only

| | | | | | | | |
|--------|--------|------|--------|--------|----|---------|-------|
| 31 | 30 | 29 | 28 | 27 | 26 | 25 | 24 |
| COMMRX | COMMTX | – | – | – | – | – | – |
| 23 | 22 | 21 | 20 | 19 | 18 | 17 | 16 |
| – | – | – | – | – | – | – | – |
| 15 | 14 | 13 | 12 | 11 | 10 | 9 | 8 |
| – | – | – | RXBUFF | TXBUFE | – | TXEMPTY | – |
| 7 | 6 | 5 | 4 | 3 | 2 | 1 | 0 |
| PARE | FRAME | OVRE | ENDTX | ENDRX | – | TXRDY | RXRDY |

- **RXRDY: Mask RXRDY Interrupt**
- **TXRDY: Disable TXRDY Interrupt**
- **ENDRX: Mask End of Receive Transfer Interrupt**
- **ENDTX: Mask End of Transmit Interrupt**
- **OVRE: Mask Overrun Error Interrupt**
- **FRAME: Mask Framing Error Interrupt**
- **PARE: Mask Parity Error Interrupt**
- **TXEMPTY: Mask TXEMPTY Interrupt**
- **TXBUFE: Mask TXBUFE Interrupt**
- **RXBUFF: Mask RXBUFF Interrupt**
- **COMMTX: Mask COMMTX Interrupt**
- **COMMRX: Mask COMMRX Interrupt**

0: The corresponding interrupt is disabled.

1: The corresponding interrupt is enabled.

27.6.6 Debug Unit Status Register

Name: DBGU_SR

Address: 0xFFFFF214

Access: Read-only

| | | | | | | | |
|--------|--------|------|--------|--------|----|---------|-------|
| 31 | 30 | 29 | 28 | 27 | 26 | 25 | 24 |
| COMMRX | COMMTX | – | – | – | – | – | – |
| 23 | 22 | 21 | 20 | 19 | 18 | 17 | 16 |
| – | – | – | – | – | – | – | – |
| 15 | 14 | 13 | 12 | 11 | 10 | 9 | 8 |
| – | – | – | RXBUFF | TXBUFE | – | TXEMPTY | – |
| 7 | 6 | 5 | 4 | 3 | 2 | 1 | 0 |
| PARE | FRAME | OVRE | ENDTX | ENDRX | – | TXRDY | RXRDY |

- **RXRDY: Receiver Ready**

0: No character has been received since the last read of the DBGU_RHR or the receiver is disabled.

1: At least one complete character has been received, transferred to DBGU_RHR and not yet read.

- **TXRDY: Transmitter Ready**

0: A character has been written to DBGU_THR and not yet transferred to the Shift Register, or the transmitter is disabled.

1: There is no character written to DBGU_THR not yet transferred to the Shift Register.

- **ENDRX: End of Receiver Transfer**

0: The End of Transfer signal from the receiver Peripheral Data Controller channel is inactive.

1: The End of Transfer signal from the receiver Peripheral Data Controller channel is active.

- **ENDTX: End of Transmitter Transfer**

0: The End of Transfer signal from the transmitter Peripheral Data Controller channel is inactive.

1: The End of Transfer signal from the transmitter Peripheral Data Controller channel is active.

- **OVRE: Overrun Error**

0: No overrun error has occurred since the last RSTSTA.

1: At least one overrun error has occurred since the last RSTSTA.

- **FRAME: Framing Error**

0: No framing error has occurred since the last RSTSTA.

1: At least one framing error has occurred since the last RSTSTA.

- **PARE: Parity Error**

0: No parity error has occurred since the last RSTSTA.

1: At least one parity error has occurred since the last RSTSTA.

- **TXEMPTY: Transmitter Empty**

0: There are characters in DBGU_THR, or characters being processed by the transmitter, or the transmitter is disabled.

1: There are no characters in DBGU_THR and there are no characters being processed by the transmitter.

- **TXBUFE: Transmission Buffer Empty**

0: The buffer empty signal from the transmitter PDC channel is inactive.

1: The buffer empty signal from the transmitter PDC channel is active.

- **RXBUFF: Receive Buffer Full**

0: The buffer full signal from the receiver PDC channel is inactive.

1: The buffer full signal from the receiver PDC channel is active.

- **COMMTX: Debug Communication Channel Write Status**

0: COMMTX from the ARM processor is inactive.

1: COMMTX from the ARM processor is active.

- **COMMRX: Debug Communication Channel Read Status**

0: COMMRX from the ARM processor is inactive.

1: COMMRX from the ARM processor is active.

27.6.7 Debug Unit Receiver Holding Register

Name: DBGU_RHR

Address: 0xFFFFF218

Access: Read-only

| | | | | | | | |
|-------|----|----|----|----|----|----|----|
| 31 | 30 | 29 | 28 | 27 | 26 | 25 | 24 |
| – | – | – | – | – | – | – | – |
| 23 | 22 | 21 | 20 | 19 | 18 | 17 | 16 |
| – | – | – | – | – | – | – | – |
| 15 | 14 | 13 | 12 | 11 | 10 | 9 | 8 |
| – | – | – | – | – | – | – | – |
| 7 | 6 | 5 | 4 | 3 | 2 | 1 | 0 |
| RXCHR | | | | | | | |

- **RXCHR: Received Character**

Last received character if RXRDY is set.

27.6.8 Debug Unit Transmit Holding Register

Name: DBGU_THR

Address: 0xFFFFF21C

Access: Write-only

| | | | | | | | |
|-------|----|----|----|----|----|----|----|
| 31 | 30 | 29 | 28 | 27 | 26 | 25 | 24 |
| – | – | – | – | – | – | – | – |
| 23 | 22 | 21 | 20 | 19 | 18 | 17 | 16 |
| – | – | – | – | – | – | – | – |
| 15 | 14 | 13 | 12 | 11 | 10 | 9 | 8 |
| – | – | – | – | – | – | – | – |
| 7 | 6 | 5 | 4 | 3 | 2 | 1 | 0 |
| TXCHR | | | | | | | |

- **TXCHR: Character to be Transmitted**

Next character to be transmitted after the current character if TXRDY is not set.

27.6.9 Debug Unit Baud Rate Generator Register

Name: DBGU_BRGR

Address: 0xFFFFF220

Access: Read/Write

| | | | | | | | |
|----|----|----|----|----|----|----|----|
| 31 | 30 | 29 | 28 | 27 | 26 | 25 | 24 |
| – | – | – | – | – | – | – | – |
| 23 | 22 | 21 | 20 | 19 | 18 | 17 | 16 |
| – | – | – | – | – | – | – | – |
| 15 | 14 | 13 | 12 | 11 | 10 | 9 | 8 |
| CD | | | | | | | |
| 7 | 6 | 5 | 4 | 3 | 2 | 1 | 0 |
| CD | | | | | | | |

• CD: Clock Divisor

| Value | Baud Rate Clock |
|------------|-----------------|
| 0 | Disabled |
| 1 | MCK |
| 2 to 65535 | MCK / (CD x 16) |

27.6.10 Debug Unit Chip ID Register

Name: DBGU_CIDR

Address: 0xFFFFF240

Access: Read-only

| | | | | | | | |
|---------|--------|----|---------|---------|----|----|----|
| 31 | 30 | 29 | 28 | 27 | 26 | 25 | 24 |
| EXT | NVPTYP | | | ARCH | | | |
| 23 | 22 | 21 | 20 | 19 | 18 | 17 | 16 |
| ARCH | | | | SRAMSIZ | | | |
| 15 | 14 | 13 | 12 | 11 | 10 | 9 | 8 |
| NVPSIZ2 | | | | NVPSIZ | | | |
| 7 | 6 | 5 | 4 | 3 | 2 | 1 | 0 |
| EPROC | | | VERSION | | | | |

- **VERSION: Version of the Device**

Current version of the device.

- **EPROC: Embedded Processor**

| Value | | | Processor |
|-------|---|---|-----------|
| 0 | 0 | 1 | ARM946ES |
| 0 | 1 | 0 | ARM7TDMI |
| 1 | 0 | 0 | ARM920T |
| 1 | 0 | 1 | ARM926EJS |

- **NVPSIZ: Nonvolatile Program Memory Size**

| Value | | | | Size |
|-------|---|---|---|-------------|
| 0 | 0 | 0 | 0 | None |
| 0 | 0 | 0 | 1 | 8 Kbytes |
| 0 | 0 | 1 | 0 | 16 Kbytes |
| 0 | 0 | 1 | 1 | 32 Kbytes |
| 0 | 1 | 0 | 0 | Reserved |
| 0 | 1 | 0 | 1 | 64 Kbytes |
| 0 | 1 | 1 | 0 | Reserved |
| 0 | 1 | 1 | 1 | 128 Kbytes |
| 1 | 0 | 0 | 0 | Reserved |
| 1 | 0 | 0 | 1 | 256 Kbytes |
| 1 | 0 | 1 | 0 | 512 Kbytes |
| 1 | 0 | 1 | 1 | Reserved |
| 1 | 1 | 0 | 0 | 1024 Kbytes |
| 1 | 1 | 0 | 1 | Reserved |
| 1 | 1 | 1 | 0 | 2048 Kbytes |
| 1 | 1 | 1 | 1 | Reserved |

• **NVPSIZ2 Second Nonvolatile Program Memory Size**

| Value | | | | Size |
|-------|---|---|---|-------------|
| 0 | 0 | 0 | 0 | None |
| 0 | 0 | 0 | 1 | 8 Kbytes |
| 0 | 0 | 1 | 0 | 16 Kbytes |
| 0 | 0 | 1 | 1 | 32 Kbytes |
| 0 | 1 | 0 | 0 | Reserved |
| 0 | 1 | 0 | 1 | 64 Kbytes |
| 0 | 1 | 1 | 0 | Reserved |
| 0 | 1 | 1 | 1 | 128 Kbytes |
| 1 | 0 | 0 | 0 | Reserved |
| 1 | 0 | 0 | 1 | 256 Kbytes |
| 1 | 0 | 1 | 0 | 512 Kbytes |
| 1 | 0 | 1 | 1 | Reserved |
| 1 | 1 | 0 | 0 | 1024 Kbytes |
| 1 | 1 | 0 | 1 | Reserved |
| 1 | 1 | 1 | 0 | 2048 Kbytes |
| 1 | 1 | 1 | 1 | Reserved |

• **SRAMSIZ: Internal SRAM Size**

| Value | | | | Size |
|-------|---|---|---|------------|
| 0 | 0 | 0 | 0 | Reserved |
| 0 | 0 | 0 | 1 | 1 Kbytes |
| 0 | 0 | 1 | 0 | 2 Kbytes |
| 0 | 0 | 1 | 1 | 6 Kbytes |
| 0 | 1 | 0 | 0 | 112 Kbytes |
| 0 | 1 | 0 | 1 | 4 Kbytes |
| 0 | 1 | 1 | 0 | 80 Kbytes |
| 0 | 1 | 1 | 1 | 160 Kbytes |
| 1 | 0 | 0 | 0 | 8 Kbytes |
| 1 | 0 | 0 | 1 | 16 Kbytes |
| 1 | 0 | 1 | 0 | 32 Kbytes |
| 1 | 0 | 1 | 1 | 64 Kbytes |
| 1 | 1 | 0 | 0 | 128 Kbytes |
| 1 | 1 | 0 | 1 | 256 Kbytes |
| 1 | 1 | 1 | 0 | 96 Kbytes |
| 1 | 1 | 1 | 1 | 512 Kbytes |

- **ARCH: Architecture Identifier**

| Value | | Architecture |
|-------|-----------|---------------------|
| Hex | Bin | |
| 0x19 | 0001 1001 | AT91SAM9xx Series |
| 0x29 | 0010 1001 | AT91SAM9XExx Series |
| 0x34 | 0011 0100 | AT91x34 Series |
| 0x37 | 0011 0111 | CAP7 Series |
| 0x39 | 0011 1001 | CAP9 Series |
| 0x3B | 0011 1011 | CAP11 Series |
| 0x40 | 0100 0000 | AT91x40 Series |
| 0x42 | 0100 0010 | AT91x42 Series |
| 0x55 | 0101 0101 | AT91x55 Series |
| 0x60 | 0110 0000 | AT91SAM7Axx Series |
| 0x61 | 0110 0001 | AT91SAM7AQxx Series |
| 0x63 | 0110 0011 | AT91x63 Series |
| 0x70 | 0111 0000 | AT91SAM7Sxx Series |
| 0x71 | 0111 0001 | AT91SAM7XCxx Series |
| 0x72 | 0111 0010 | AT91SAM7SExx Series |
| 0x73 | 0111 0011 | AT91SAM7Lxx Series |
| 0x75 | 0111 0101 | AT91SAM7Xxx Series |
| 0x92 | 1001 0010 | AT91x92 Series |
| 0xF0 | 1111 0000 | AT75Cxx Series |

- **NVPTYP: Nonvolatile Program Memory Type**

| Value | | | Memory |
|-------|---|---|--|
| 0 | 0 | 0 | ROM |
| 0 | 0 | 1 | ROMless or on-chip Flash |
| 1 | 0 | 0 | SRAM emulating ROM |
| 0 | 1 | 0 | Embedded Flash Memory |
| 0 | 1 | 1 | ROM and Embedded Flash Memory NVPSIZ is ROM size NVPSIZ2 is Flash size |

- **EXT: Extension Flag**

0: Chip ID has a single register definition without extension

1: An extended Chip ID exists.

27.6.11 Debug Unit Chip ID Extension Register

Name: DBGU_EXID

Address: 0xFFFFF244

Access: Read-only

| | | | | | | | |
|------|----|----|----|----|----|----|----|
| 31 | 30 | 29 | 28 | 27 | 26 | 25 | 24 |
| EXID | | | | | | | |
| 23 | 22 | 21 | 20 | 19 | 18 | 17 | 16 |
| EXID | | | | | | | |
| 15 | 14 | 13 | 12 | 11 | 10 | 9 | 8 |
| EXID | | | | | | | |
| 7 | 6 | 5 | 4 | 3 | 2 | 1 | 0 |
| EXID | | | | | | | |

- **EXID: Chip ID Extension**

Reads 0 if the bit EXT in DBGU_CIDR is 0.

27.6.12 Debug Unit Force NTRST Register

Name: DBGU_FNR

Address: 0xFFFFF248

Access: Read/Write

| | | | | | | | |
|----|----|----|----|----|----|----|--------|
| 31 | 30 | 29 | 28 | 27 | 26 | 25 | 24 |
| – | – | – | – | – | – | – | – |
| 23 | 22 | 21 | 20 | 19 | 18 | 17 | 16 |
| – | – | – | – | – | – | – | – |
| 15 | 14 | 13 | 12 | 11 | 10 | 9 | 8 |
| – | – | – | – | – | – | – | – |
| 7 | 6 | 5 | 4 | 3 | 2 | 1 | 0 |
| – | – | – | – | – | – | – | FNTRST |

- **FNTRST: Force NTRST**

0: NTRST of the ARM processor's TAP controller is driven by the power_on_reset signal.

1: NTRST of the ARM processor's TAP controller is held low.

28. Peripheral Input/Output Controller (PIO)

28.1 Overview

The Parallel Input/Output Controller (PIO) manages up to 32 fully programmable input/output lines. Each I/O line may be dedicated as a general-purpose I/O or be assigned to a function of an embedded peripheral. This assures effective optimization of the pins of a product.

Each I/O line is associated with a bit number in all of the 32-bit registers of the 32-bit wide User Interface.

Each I/O line of the PIO Controller features:

- An input change interrupt enabling level change detection on any I/O line.
- A glitch filter providing rejection of pulses lower than one-half of clock cycle.
- Multi-drive capability similar to an open drain I/O line.
- Control of the pull-up of the I/O line.
- Input visibility and output control.

The PIO Controller also features a synchronous output providing up to 32 bits of data output in a single write operation.

28.2 Block Diagram

Figure 28-1. Block Diagram

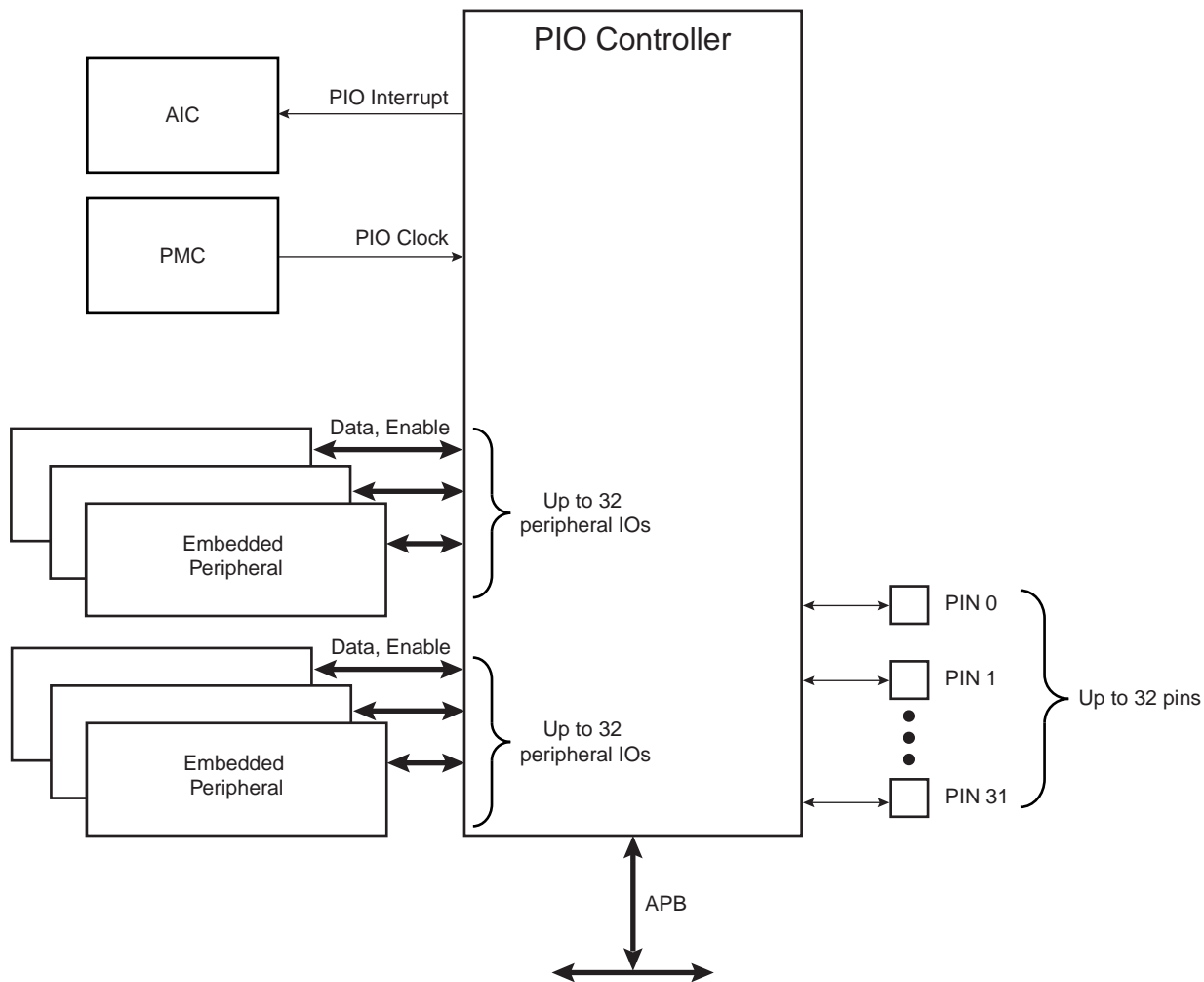
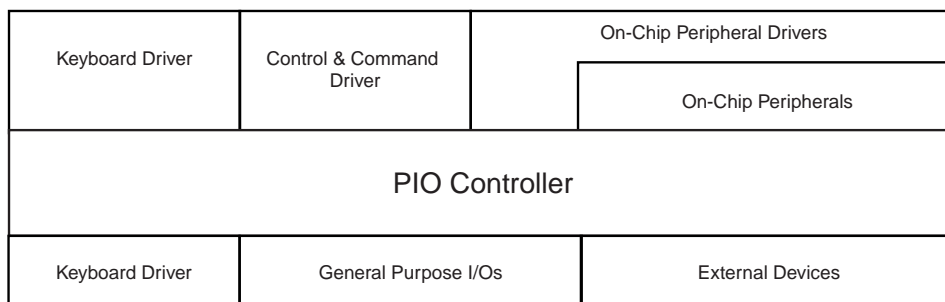

Figure 28-2. Application Block Diagram



28.3 Product Dependencies

28.3.1 Pin Multiplexing

Each pin is configurable, according to product definition as either a general-purpose I/O line only, or as an I/O line multiplexed with one or two peripheral I/Os. As the multiplexing is hardware-defined and thus product-dependent, the hardware designer and programmer must carefully determine the configuration of the PIO controllers required by their application. When an I/O line is general-purpose only, i.e. not multiplexed with any peripheral I/O, programming of the PIO Controller regarding the assignment to a peripheral has no effect and only the PIO Controller can control how the pin is driven by the product.

28.3.2 External Interrupt Lines

The interrupt signals FIQ and IRQ0 to IRQn are most generally multiplexed through the PIO Controllers. However, it is not necessary to assign the I/O line to the interrupt function as the PIO Controller has no effect on inputs and the interrupt lines (FIQ or IRQs) are used only as inputs.

28.3.3 Power Management

The Power Management Controller controls the PIO Controller clock in order to save power. Writing any of the registers of the user interface does not require the PIO Controller clock to be enabled. This means that the configuration of the I/O lines does not require the PIO Controller clock to be enabled.

However, when the clock is disabled, not all of the features of the PIO Controller are available. Note that the Input Change Interrupt and the read of the pin level require the clock to be validated.

After a hardware reset, the PIO clock is disabled by default.

The user must configure the Power Management Controller before any access to the input line information.

28.3.4 Interrupt Generation

For interrupt handling, the PIO Controllers are considered as user peripherals. This means that the PIO Controller interrupt lines are connected among the interrupt sources 2 to 31. Refer to the PIO Controller peripheral identifier in the product description to identify the interrupt sources dedicated to the PIO Controllers.

The PIO Controller interrupt can be generated only if the PIO Controller clock is enabled.

28.4 Functional Description

The PIO Controller features up to 32 fully-programmable I/O lines. Most of the control logic associated to each I/O is represented in [Figure 28-3](#). In this description each signal shown represents but one of up to 32 possible indexes.

Figure 28-3. I/O Line Control Logic

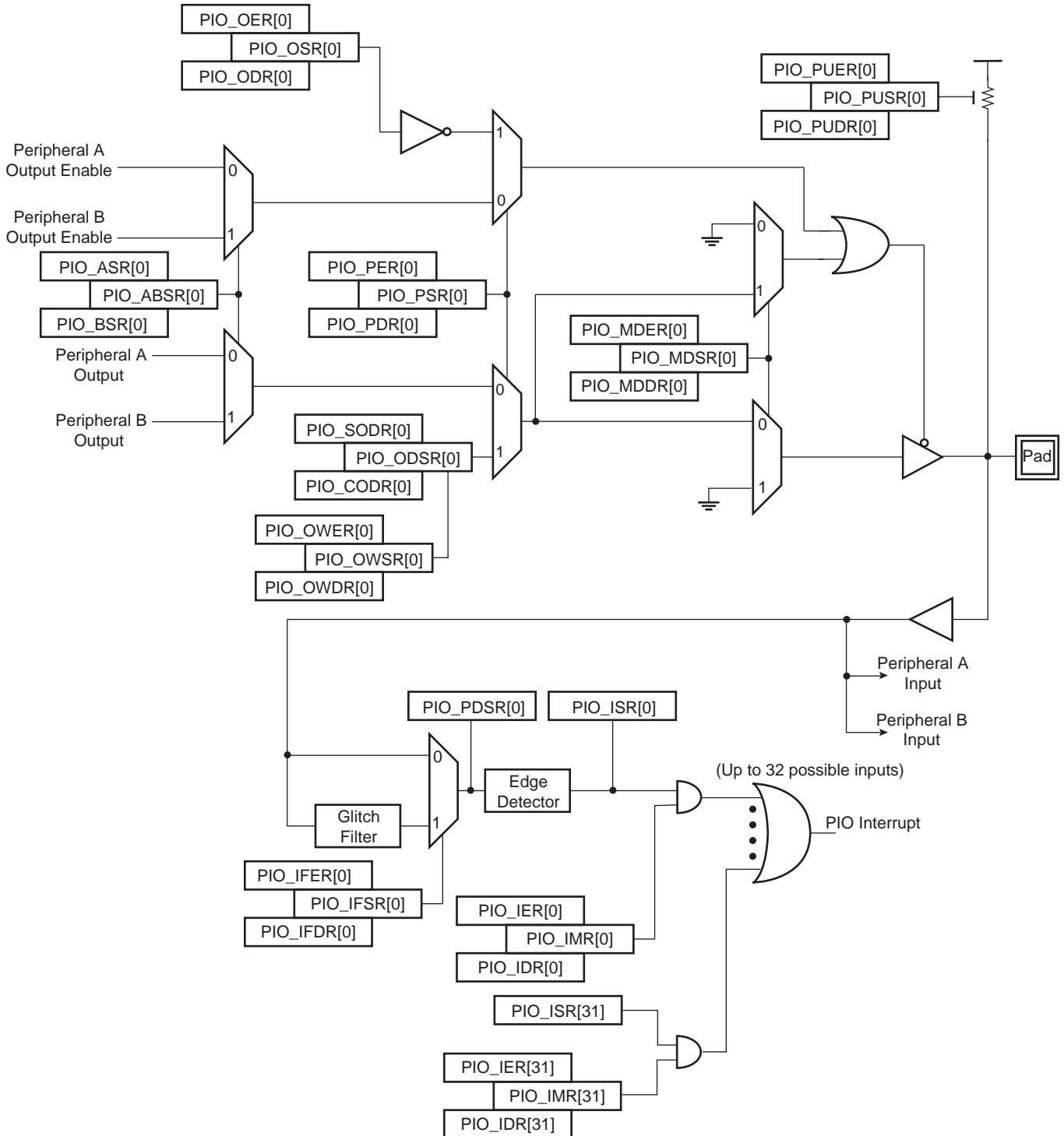

28.4.1 Pull-up Resistor Control

Each I/O line is designed with an embedded pull-up resistor. The pull-up resistor can be enabled or disabled by writing respectively PIO_PUER (Pull-up Enable Register) and PIO_PUDR (Pull-up Disable Register). Writing in these registers results in setting or clearing the corresponding bit in PIO_PUSR (Pull-up Status Register). Reading a 1 in PIO_PUSR means the pull-up is disabled and reading a 0 means the pull-up is enabled.

Control of the pull-up resistor is possible regardless of the configuration of the I/O line.

After reset, all of the pull-ups are enabled, i.e. PIO_PUSR resets at the value 0x0.

28.4.2 I/O Line or Peripheral Function Selection

When a pin is multiplexed with one or two peripheral functions, the selection is controlled with the registers PIO_PER (PIO Enable Register) and PIO_PDR (PIO Disable Register). The register PIO_PSR (PIO Status Register) is the result of the set and clear registers and indicates whether the pin is controlled by the corresponding peripheral or by the PIO Controller. A value of 0 indicates that the pin is controlled by the corresponding on-chip peripheral selected in the PIO_ABSR (AB Select Status Register). A value of 1 indicates the pin is controlled by the PIO controller.

If a pin is used as a general purpose I/O line (not multiplexed with an on-chip peripheral), PIO_PER and PIO_PDR have no effect and PIO_PSR returns 1 for the corresponding bit.

After reset, most generally, the I/O lines are controlled by the PIO controller, i.e. PIO_PSR resets at 1. However, in some events, it is important that PIO lines are controlled by the peripheral (as in the case of memory chip select lines that must be driven inactive after reset or for address lines that must be driven low for booting out of an external memory). Thus, the reset value of PIO_PSR is defined at the product level, depending on the multiplexing of the device.

28.4.3 Peripheral A or B Selection

The PIO Controller provides multiplexing of up to two peripheral functions on a single pin. The selection is performed by writing PIO_ASR (A Select Register) and PIO_BSR (Select B Register). PIO_ABSR (AB Select Status Register) indicates which peripheral line is currently selected. For each pin, the corresponding bit at level 0 means peripheral A is selected whereas the corresponding bit at level 1 indicates that peripheral B is selected.

Note that multiplexing of peripheral lines A and B only affects the output line. The peripheral input lines are always connected to the pin input.

After reset, PIO_ABSR is 0, thus indicating that all the PIO lines are configured on peripheral A. However, peripheral A generally does not drive the pin as the PIO Controller resets in I/O line mode.

Writing in PIO_ASR and PIO_BSR manages PIO_ABSR regardless of the configuration of the pin. However, assignment of a pin to a peripheral function requires a write in the corresponding peripheral selection register (PIO_ASR or PIO_BSR) in addition to a write in PIO_PDR.

28.4.4 Output Control

When the I/O line is assigned to a peripheral function, i.e. the corresponding bit in PIO_PSR is at 0, the drive of the I/O line is controlled by the peripheral. Peripheral A or B, depending on the value in PIO_ABSR, determines whether the pin is driven or not.

When the I/O line is controlled by the PIO controller, the pin can be configured to be driven. This is done by writing PIO_OER (Output Enable Register) and PIO_ODR (Output Disable Register). The results of these write operations are detected in PIO_OSR (Output Status Register). When a bit in this register is at 0, the corresponding I/O line is used as an input only. When the bit is at 1, the corresponding I/O line is driven by the PIO controller.

The level driven on an I/O line can be determined by writing in PIO_SODR (Set Output Data Register) and PIO_CODR (Clear Output Data Register). These write operations respectively set and clear PIO_ODSR (Output Data Status Register), which represents the data driven on the I/O lines. Writing in PIO_OER and PIO_ODR

manages PIO_OSR whether the pin is configured to be controlled by the PIO controller or assigned to a peripheral function. This enables configuration of the I/O line prior to setting it to be managed by the PIO Controller.

Similarly, writing in PIO_SODR and PIO_CODR effects PIO_ODSR. This is important as it defines the first level driven on the I/O line.

28.4.5 Synchronous Data Output

Controlling all parallel busses using several PIOs requires two successive write operations in the PIO_SODR and PIO_CODR. This may lead to unexpected transient values. The PIO controller offers a direct control of PIO outputs by single write access to PIO_ODSR (Output Data Status Register). Only bits unmasked by PIO_OWSR (Output Write Status Register) are written. The mask bits in the PIO_OWSR are set by writing to PIO_OWER (Output Write Enable Register) and cleared by writing to PIO_OWDR (Output Write Disable Register).

After reset, the synchronous data output is disabled on all the I/O lines as PIO_OWSR resets at 0x0.

28.4.6 Multi Drive Control (Open Drain)

Each I/O can be independently programmed in Open Drain by using the Multi Drive feature. This feature permits several drivers to be connected on the I/O line which is driven low only by each device. An external pull-up resistor (or enabling of the internal one) is generally required to guarantee a high level on the line.

The Multi Drive feature is controlled by PIO_MDER (Multi-driver Enable Register) and PIO_MDDR (Multi-driver Disable Register). The Multi Drive can be selected whether the I/O line is controlled by the PIO controller or assigned to a peripheral function. PIO_MDSR (Multi-driver Status Register) indicates the pins that are configured to support external drivers.

After reset, the Multi Drive feature is disabled on all pins, i.e. PIO_MDSR resets at value 0x0.

28.4.7 Output Line Timings

Figure 28-4 shows how the outputs are driven either by writing PIO_SODR or PIO_CODR, or by directly writing PIO_ODSR. This last case is valid only if the corresponding bit in PIO_OWSR is set. Figure 28-4 also shows when the feedback in PIO_PDSR is available.

Figure 28-4. Output Line Timings

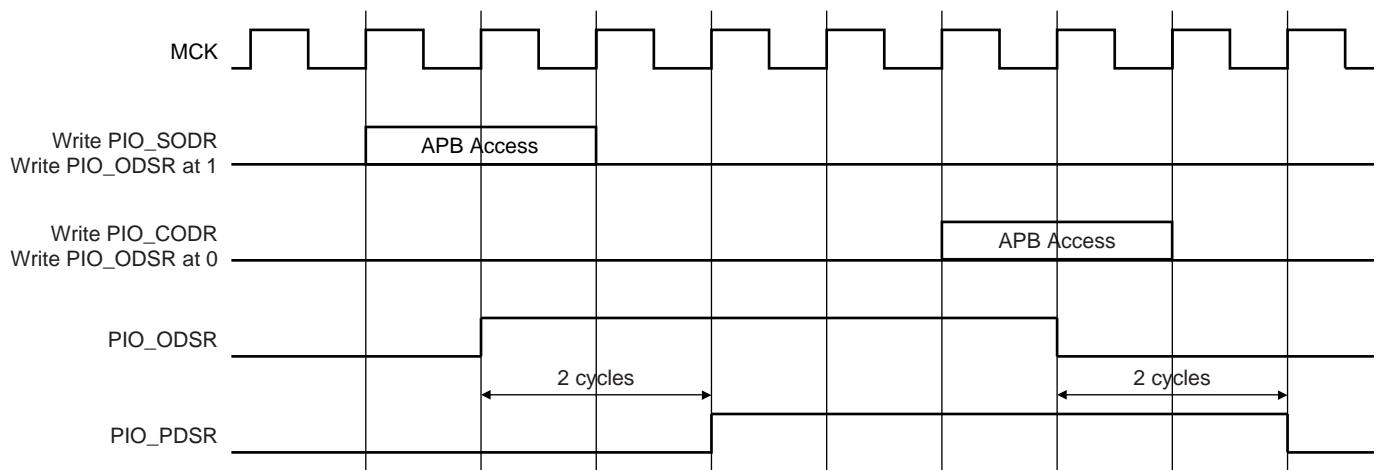

28.4.8 Inputs

The level on each I/O line can be read through PIO_PDSR (Pin Data Status Register). This register indicates the level of the I/O lines regardless of their configuration, whether uniquely as an input or driven by the PIO controller or driven by a peripheral.

Reading the I/O line levels requires the clock of the PIO controller to be enabled, otherwise PIO_PDSR reads the levels present on the I/O line at the time the clock was disabled.

28.4.9 Input Glitch Filtering

Optional input glitch filters are independently programmable on each I/O line. When the glitch filter is enabled, a glitch with a duration of less than 1/2 Master Clock (MCK) cycle is automatically rejected, while a pulse with a duration of 1 Master Clock cycle or more is accepted. For pulse durations between 1/2 Master Clock cycle and 1 Master Clock cycle the pulse may or may not be taken into account, depending on the precise timing of its occurrence. Thus for a pulse to be visible it must exceed 1 Master Clock cycle, whereas for a glitch to be reliably filtered out, its duration must not exceed 1/2 Master Clock cycle. The filter introduces one Master Clock cycle latency if the pin level change occurs before a rising edge. However, this latency does not appear if the pin level change occurs before a falling edge. This is illustrated in Figure 28-5.

The glitch filters are controlled by the register set; PIO_IFER (Input Filter Enable Register), PIO_IFDR (Input Filter Disable Register) and PIO_IFSR (Input Filter Status Register). Writing PIO_IFER and PIO_IFDR respectively sets and clears bits in PIO_IFSR. This last register enables the glitch filter on the I/O lines.

When the glitch filter is enabled, it does not modify the behavior of the inputs on the peripherals. It acts only on the value read in PIO_PDSR and on the input change interrupt detection. The glitch filters require that the PIO Controller clock is enabled.

Figure 28-5. Input Glitch Filter Timing

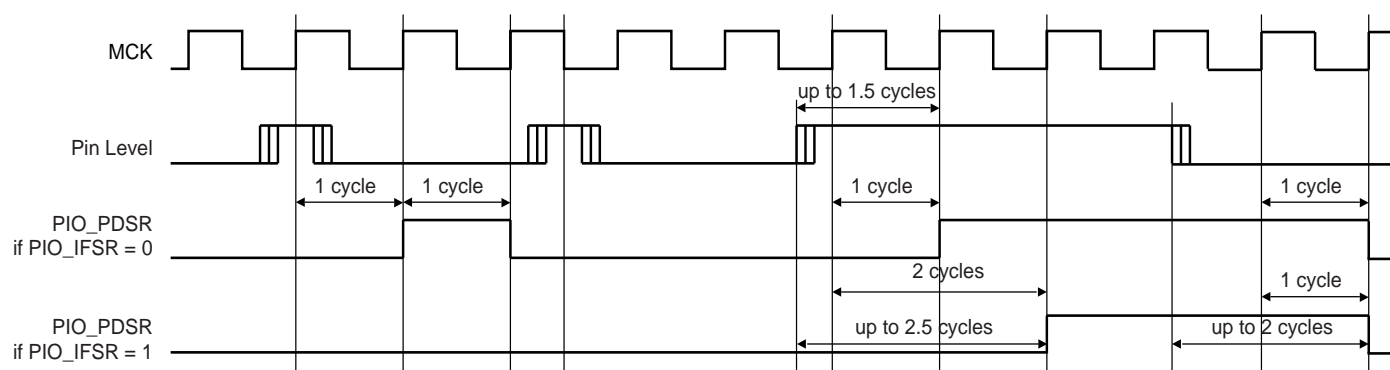

28.4.10 Input Change Interrupt

The PIO Controller can be programmed to generate an interrupt when it detects an input change on an I/O line. The Input Change Interrupt is controlled by writing PIO_IER (Interrupt Enable Register) and PIO_IDR (Interrupt Disable Register), which respectively enable and disable the input change interrupt by setting and clearing the corresponding bit in PIO_IMR (Interrupt Mask Register). As Input change detection is possible only by comparing two successive samplings of the input of the I/O line, the PIO Controller clock must be enabled. The Input Change Interrupt is available, regardless of the configuration of the I/O line, i.e. configured as an input only, controlled by the PIO Controller or assigned to a peripheral function.

When an input change is detected on an I/O line, the corresponding bit in PIO_ISR (Interrupt Status Register) is set. If the corresponding bit in PIO_IMR is set, the PIO Controller interrupt line is asserted. The interrupt signals of the thirty-two channels are ORed-wired together to generate a single interrupt signal to the Advanced Interrupt Controller.

When the software reads PIO_ISR, all the interrupts are automatically cleared. This signifies that all the interrupts that are pending when PIO_ISR is read must be handled.

Figure 28-6. Input Change Interrupt Timings

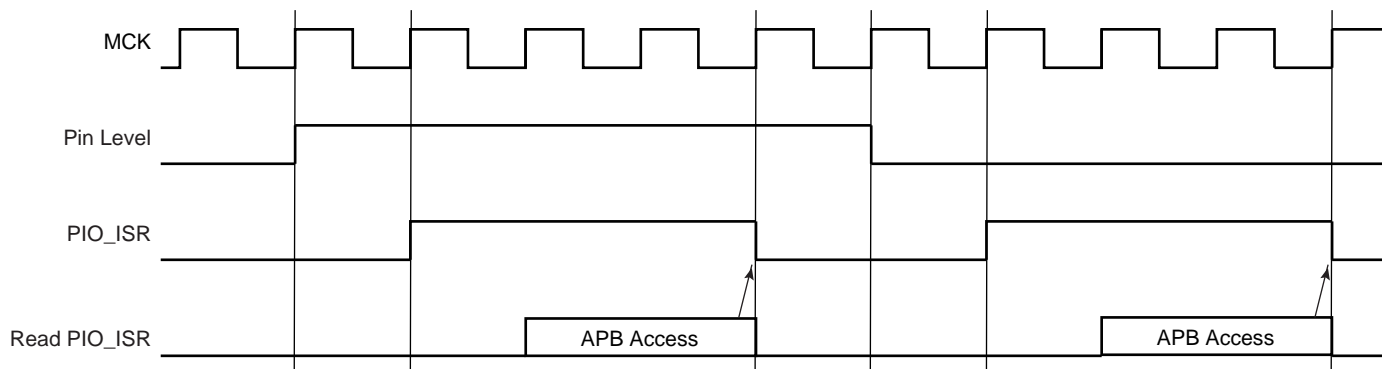

28.5 I/O Lines Programming Example

The programming example as shown in [Table 28-1](#) below is used to define the following configuration.

- 4-bit output port on I/O lines 0 to 3, (should be written in a single write operation), open-drain, with pull-up resistor
- Four output signals on I/O lines 4 to 7 (to drive LEDs for example), driven high and low, no pull-up resistor
- Four input signals on I/O lines 8 to 11 (to read push-button states for example), with pull-up resistors, glitch filters and input change interrupts
- Four input signals on I/O line 12 to 15 to read an external device status (polled, thus no input change interrupt), no pull-up resistor, no glitch filter
- I/O lines 16 to 19 assigned to peripheral A functions with pull-up resistor
- I/O lines 20 to 23 assigned to peripheral B functions, no pull-up resistor
- I/O line 24 to 27 assigned to peripheral A with Input Change Interrupt and pull-up resistor

Table 28-1. Programming Example

| Register | Value to be Written |
|----------|---------------------|
| PIO_PER | 0x0000 FFFF |
| PIO_PDR | 0x0FFF 0000 |
| PIO_OER | 0x0000 00FF |
| PIO_ODR | 0x0FFF FF00 |
| PIO_IFER | 0x0000 0F00 |
| PIO_IFDR | 0x0FFF F0FF |
| PIO_SODR | 0x0000 0000 |
| PIO_CODR | 0x0FFF FFFF |
| PIO_IER | 0x0F00 0F00 |
| PIO_IDR | 0x00FF F0FF |
| PIO_MDER | 0x0000 000F |
| PIO_MDDR | 0x0FFF FFF0 |
| PIO_PUDR | 0x00F0 00F0 |
| PIO_PUER | 0x0F0F FF0F |
| PIO_ASR | 0x0F0F 0000 |
| PIO_BSR | 0x00F0 0000 |
| PIO_OWER | 0x0000 000F |
| PIO_OWDR | 0x0FFF FFF0 |

28.6 Parallel Input/Output Controller (PIO) User Interface

Each I/O line controlled by the PIO Controller is associated with a bit in each of the PIO Controller User Interface registers. Each register is 32 bits wide. If a parallel I/O line is not defined, writing to the corresponding bits has no effect. Undefined bits read zero. If the I/O line is not multiplexed with any peripheral, the I/O line is controlled by the PIO Controller and PIO_PSR returns 1 systematically.

Table 28-2. Register Mapping

| Offset | Register | Name | Access | Reset |
|--------|---|----------|--|-------------|
| 0x0000 | PIO Enable Register | PIO_PER | Write-only | – |
| 0x0004 | PIO Disable Register | PIO_PDR | Write-only | – |
| 0x0008 | PIO Status Register | PIO_PSR | Read-only | (1) |
| 0x000C | Reserved | – | – | – |
| 0x0010 | Output Enable Register | PIO_OER | Write-only | – |
| 0x0014 | Output Disable Register | PIO_ODR | Write-only | – |
| 0x0018 | Output Status Register | PIO_OSR | Read-only | 0x0000 0000 |
| 0x001C | Reserved | – | – | – |
| 0x0020 | Glitch Input Filter Enable Register | PIO_IFER | Write-only | – |
| 0x0024 | Glitch Input Filter Disable Register | PIO_IFDR | Write-only | – |
| 0x0028 | Glitch Input Filter Status Register | PIO_IFSR | Read-only | 0x0000 0000 |
| 0x002C | Reserved | – | – | – |
| 0x0030 | Set Output Data Register | PIO_SODR | Write-only | – |
| 0x0034 | Clear Output Data Register | PIO_CODR | Write-only | – |
| 0x0038 | Output Data Status Register | PIO_ODSR | Read-only or ⁽²⁾ Read/Write | – |
| 0x003C | Pin Data Status Register | PIO_PDSR | Read-only | (3) |
| 0x0040 | Interrupt Enable Register | PIO_IER | Write-only | – |
| 0x0044 | Interrupt Disable Register | PIO_IDR | Write-only | – |
| 0x0048 | Interrupt Mask Register | PIO_IMR | Read-only | 0x00000000 |
| 0x004C | Interrupt Status Register ⁽⁴⁾ | PIO_ISR | Read-only | 0x00000000 |
| 0x0050 | Multi-driver Enable Register | PIO_MDER | Write-only | – |
| 0x0054 | Multi-driver Disable Register | PIO_MDDR | Write-only | – |
| 0x0058 | Multi-driver Status Register | PIO_MDSR | Read-only | 0x00000000 |
| 0x005C | Reserved | – | – | – |
| 0x0060 | Pull-up Disable Register | PIO_PUDR | Write-only | – |
| 0x0064 | Pull-up Enable Register | PIO_PUER | Write-only | – |
| 0x0068 | Pad Pull-up Status Register | PIO_PUSR | Read-only | 0x00000000 |
| 0x006C | Reserved | – | – | – |
| 0x0070 | Peripheral A Select Register ⁽⁵⁾ | PIO_ASR | Write-only | – |
| 0x0074 | Peripheral B Select Register ⁽⁵⁾ | PIO_BSR | Write-only | – |
| 0x0078 | AB Status Register ⁽⁵⁾ | PIO_ABSR | Read-only | 0x00000000 |

Table 28-2. Register Mapping (Continued)

| Offset | Register | Name | Access | Reset |
|---------------|------------------------------|----------|------------|------------|
| 0x007C–0x009C | Reserved | – | – | – |
| 0x00A0 | Output Write Enable | PIO_OWER | Write-only | – |
| 0x00A4 | Output Write Disable | PIO_OWDR | Write-only | – |
| 0x00A8 | Output Write Status Register | PIO_OWSR | Read-only | 0x00000000 |
| 0x00AC | Reserved | – | – | – |

- Notes:
1. Reset value of PIO_PSR depends on the product implementation.
 2. PIO_ODSR is Read-only or Read/Write depending on PIO_OWSR I/O lines.
 3. Reset value of PIO_PDSR depends on the level of the I/O lines. Reading the I/O line levels requires the clock of the PIO Controller to be enabled, otherwise PIO_PDSR reads the levels present on the I/O line at the time the clock was disabled.
 4. PIO_ISR is reset at 0x0. However, the first read of the register may read a different value as input changes may have occurred.
 5. Only this set of registers clears the status by writing 1 in the first register and sets the status by writing 1 in the second register.

28.6.1 PIO Controller PIO Enable Register

Name: PIO_PER

Address: 0xFFFFF400 (PIOA), 0xFFFFF600 (PIOB), 0xFFFFF800 (PIOC)

Access: Write-only

| | | | | | | | |
|-----|-----|-----|-----|-----|-----|-----|-----|
| 31 | 30 | 29 | 28 | 27 | 26 | 25 | 24 |
| P31 | P30 | P29 | P28 | P27 | P26 | P25 | P24 |
| 23 | 22 | 21 | 20 | 19 | 18 | 17 | 16 |
| P23 | P22 | P21 | P20 | P19 | P18 | P17 | P16 |
| 15 | 14 | 13 | 12 | 11 | 10 | 9 | 8 |
| P15 | P14 | P13 | P12 | P11 | P10 | P9 | P8 |
| 7 | 6 | 5 | 4 | 3 | 2 | 1 | 0 |
| P7 | P6 | P5 | P4 | P3 | P2 | P1 | P0 |

- **P0-P31: PIO Enable**

0: No effect.

1: Enables the PIO to control the corresponding pin (disables peripheral control of the pin).

28.6.2 PIO Controller PIO Disable Register

Name: PIO_PDR

Address: 0xFFFFF404 (PIOA), 0xFFFFF604 (PIOB), 0xFFFFF804 (PIOC)

Access: Write-only

| | | | | | | | |
|-----|-----|-----|-----|-----|-----|-----|-----|
| 31 | 30 | 29 | 28 | 27 | 26 | 25 | 24 |
| P31 | P30 | P29 | P28 | P27 | P26 | P25 | P24 |
| 23 | 22 | 21 | 20 | 19 | 18 | 17 | 16 |
| P23 | P22 | P21 | P20 | P19 | P18 | P17 | P16 |
| 15 | 14 | 13 | 12 | 11 | 10 | 9 | 8 |
| P15 | P14 | P13 | P12 | P11 | P10 | P9 | P8 |
| 7 | 6 | 5 | 4 | 3 | 2 | 1 | 0 |
| P7 | P6 | P5 | P4 | P3 | P2 | P1 | P0 |

- **P0-P31: PIO Disable**

0: No effect.

1: Disables the PIO from controlling the corresponding pin (enables peripheral control of the pin).

28.6.3 PIO Controller PIO Status Register

Name: PIO_PSR

Address: 0xFFFFF408 (PIOA), 0xFFFFF608 (PIOB), 0xFFFFF808 (PIOC)

Access: Read-only

| | | | | | | | |
|-----|-----|-----|-----|-----|-----|-----|-----|
| 31 | 30 | 29 | 28 | 27 | 26 | 25 | 24 |
| P31 | P30 | P29 | P28 | P27 | P26 | P25 | P24 |
| 23 | 22 | 21 | 20 | 19 | 18 | 17 | 16 |
| P23 | P22 | P21 | P20 | P19 | P18 | P17 | P16 |
| 15 | 14 | 13 | 12 | 11 | 10 | 9 | 8 |
| P15 | P14 | P13 | P12 | P11 | P10 | P9 | P8 |
| 7 | 6 | 5 | 4 | 3 | 2 | 1 | 0 |
| P7 | P6 | P5 | P4 | P3 | P2 | P1 | P0 |

- **P0-P31: PIO Status**

0: PIO is inactive on the corresponding I/O line (peripheral is active).

1: PIO is active on the corresponding I/O line (peripheral is inactive).

28.6.4 PIO Controller Output Enable Register

Name: PIO_OER

Address: 0xFFFFF410 (PIOA), 0xFFFFF610 (PIOB), 0xFFFFF810 (PIOC)

Access: Write-only

| | | | | | | | |
|-----|-----|-----|-----|-----|-----|-----|-----|
| 31 | 30 | 29 | 28 | 27 | 26 | 25 | 24 |
| P31 | P30 | P29 | P28 | P27 | P26 | P25 | P24 |
| 23 | 22 | 21 | 20 | 19 | 18 | 17 | 16 |
| P23 | P22 | P21 | P20 | P19 | P18 | P17 | P16 |
| 15 | 14 | 13 | 12 | 11 | 10 | 9 | 8 |
| P15 | P14 | P13 | P12 | P11 | P10 | P9 | P8 |
| 7 | 6 | 5 | 4 | 3 | 2 | 1 | 0 |
| P7 | P6 | P5 | P4 | P3 | P2 | P1 | P0 |

- **P0-P31: Output Enable**

0: No effect.

1: Enables the output on the I/O line.

28.6.5 PIO Controller Output Disable Register

Name: PIO_ODR

Address: 0xFFFFF414 (PIOA), 0xFFFFF614 (PIOB), 0xFFFFF814 (PIOC)

Access: Write-only

| | | | | | | | |
|-----|-----|-----|-----|-----|-----|-----|-----|
| 31 | 30 | 29 | 28 | 27 | 26 | 25 | 24 |
| P31 | P30 | P29 | P28 | P27 | P26 | P25 | P24 |
| 23 | 22 | 21 | 20 | 19 | 18 | 17 | 16 |
| P23 | P22 | P21 | P20 | P19 | P18 | P17 | P16 |
| 15 | 14 | 13 | 12 | 11 | 10 | 9 | 8 |
| P15 | P14 | P13 | P12 | P11 | P10 | P9 | P8 |
| 7 | 6 | 5 | 4 | 3 | 2 | 1 | 0 |
| P7 | P6 | P5 | P4 | P3 | P2 | P1 | P0 |

- **P0-P31: Output Disable**

0: No effect.

1: Disables the output on the I/O line.

28.6.6 PIO Controller Output Status Register

Name: PIO_OSR

Address: 0xFFFFF418 (PIOA), 0xFFFFF618 (PIOB), 0xFFFFF818 (PIOC)

Access: Read-only

| | | | | | | | |
|-----|-----|-----|-----|-----|-----|-----|-----|
| 31 | 30 | 29 | 28 | 27 | 26 | 25 | 24 |
| P31 | P30 | P29 | P28 | P27 | P26 | P25 | P24 |
| 23 | 22 | 21 | 20 | 19 | 18 | 17 | 16 |
| P23 | P22 | P21 | P20 | P19 | P18 | P17 | P16 |
| 15 | 14 | 13 | 12 | 11 | 10 | 9 | 8 |
| P15 | P14 | P13 | P12 | P11 | P10 | P9 | P8 |
| 7 | 6 | 5 | 4 | 3 | 2 | 1 | 0 |
| P7 | P6 | P5 | P4 | P3 | P2 | P1 | P0 |

- **P0-P31: Output Status**

0: The I/O line is a pure input.

1: The I/O line is enabled in output.

28.6.7 PIO Controller Input Filter Enable Register

Name: PIO_IFER

Address: 0xFFFFF420 (PIOA), 0xFFFFF620 (PIOB), 0xFFFFF820 (PIOC)

Access: Write-only

| | | | | | | | |
|-----|-----|-----|-----|-----|-----|-----|-----|
| 31 | 30 | 29 | 28 | 27 | 26 | 25 | 24 |
| P31 | P30 | P29 | P28 | P27 | P26 | P25 | P24 |
| 23 | 22 | 21 | 20 | 19 | 18 | 17 | 16 |
| P23 | P22 | P21 | P20 | P19 | P18 | P17 | P16 |
| 15 | 14 | 13 | 12 | 11 | 10 | 9 | 8 |
| P15 | P14 | P13 | P12 | P11 | P10 | P9 | P8 |
| 7 | 6 | 5 | 4 | 3 | 2 | 1 | 0 |
| P7 | P6 | P5 | P4 | P3 | P2 | P1 | P0 |

- **P0-P31: Input Filter Enable**

0: No effect.

1: Enables the input glitch filter on the I/O line.

28.6.8 PIO Controller Input Filter Disable Register

Name: PIO_IFDR

Address: 0xFFFFF424 (PIOA), 0xFFFFF624 (PIOB), 0xFFFFF824 (PIOC)

Access: Write-only

| | | | | | | | |
|-----|-----|-----|-----|-----|-----|-----|-----|
| 31 | 30 | 29 | 28 | 27 | 26 | 25 | 24 |
| P31 | P30 | P29 | P28 | P27 | P26 | P25 | P24 |
| 23 | 22 | 21 | 20 | 19 | 18 | 17 | 16 |
| P23 | P22 | P21 | P20 | P19 | P18 | P17 | P16 |
| 15 | 14 | 13 | 12 | 11 | 10 | 9 | 8 |
| P15 | P14 | P13 | P12 | P11 | P10 | P9 | P8 |
| 7 | 6 | 5 | 4 | 3 | 2 | 1 | 0 |
| P7 | P6 | P5 | P4 | P3 | P2 | P1 | P0 |

- **P0-P31: Input Filter Disable**

0: No effect.

1: Disables the input glitch filter on the I/O line.

28.6.9 PIO Controller Input Filter Status Register

Name: PIO_IFSR

Address: 0xFFFFF428 (PIOA), 0xFFFFF628 (PIOB), 0xFFFFF828 (PIOC)

Access: Read-only

| | | | | | | | |
|-----|-----|-----|-----|-----|-----|-----|-----|
| 31 | 30 | 29 | 28 | 27 | 26 | 25 | 24 |
| P31 | P30 | P29 | P28 | P27 | P26 | P25 | P24 |
| 23 | 22 | 21 | 20 | 19 | 18 | 17 | 16 |
| P23 | P22 | P21 | P20 | P19 | P18 | P17 | P16 |
| 15 | 14 | 13 | 12 | 11 | 10 | 9 | 8 |
| P15 | P14 | P13 | P12 | P11 | P10 | P9 | P8 |
| 7 | 6 | 5 | 4 | 3 | 2 | 1 | 0 |
| P7 | P6 | P5 | P4 | P3 | P2 | P1 | P0 |

- **P0-P31: Input Filter Status**

0: The input glitch filter is disabled on the I/O line.

1: The input glitch filter is enabled on the I/O line.

28.6.10 PIO Controller Set Output Data Register

Name: PIO_SODR

Address: 0xFFFFF430 (PIOA), 0xFFFFF630 (PIOB), 0xFFFFF830 (PIOC)

Access: Write-only

| | | | | | | | |
|-----|-----|-----|-----|-----|-----|-----|-----|
| 31 | 30 | 29 | 28 | 27 | 26 | 25 | 24 |
| P31 | P30 | P29 | P28 | P27 | P26 | P25 | P24 |
| 23 | 22 | 21 | 20 | 19 | 18 | 17 | 16 |
| P23 | P22 | P21 | P20 | P19 | P18 | P17 | P16 |
| 15 | 14 | 13 | 12 | 11 | 10 | 9 | 8 |
| P15 | P14 | P13 | P12 | P11 | P10 | P9 | P8 |
| 7 | 6 | 5 | 4 | 3 | 2 | 1 | 0 |
| P7 | P6 | P5 | P4 | P3 | P2 | P1 | P0 |

- **P0-P31: Set Output Data**

0: No effect.

1: Sets the data to be driven on the I/O line.

28.6.11 PIO Controller Clear Output Data Register

Name: PIO_CODR

Address: 0xFFFFF434 (PIOA), 0xFFFFF634 (PIOB), 0xFFFFF834 (PIOC)

Access: Write-only

| | | | | | | | |
|-----|-----|-----|-----|-----|-----|-----|-----|
| 31 | 30 | 29 | 28 | 27 | 26 | 25 | 24 |
| P31 | P30 | P29 | P28 | P27 | P26 | P25 | P24 |
| 23 | 22 | 21 | 20 | 19 | 18 | 17 | 16 |
| P23 | P22 | P21 | P20 | P19 | P18 | P17 | P16 |
| 15 | 14 | 13 | 12 | 11 | 10 | 9 | 8 |
| P15 | P14 | P13 | P12 | P11 | P10 | P9 | P8 |
| 7 | 6 | 5 | 4 | 3 | 2 | 1 | 0 |
| P7 | P6 | P5 | P4 | P3 | P2 | P1 | P0 |

- **P0-P31: Set Output Data**

0: No effect.

1: Clears the data to be driven on the I/O line.

28.6.12 PIO Controller Output Data Status Register

Name: PIO_ODSR

Address: 0xFFFFF438 (PIOA), 0xFFFFF638 (PIOB), 0xFFFFF838 (PIOC)

Access: Read-only or Read/Write

| | | | | | | | |
|-----|-----|-----|-----|-----|-----|-----|-----|
| 31 | 30 | 29 | 28 | 27 | 26 | 25 | 24 |
| P31 | P30 | P29 | P28 | P27 | P26 | P25 | P24 |
| 23 | 22 | 21 | 20 | 19 | 18 | 17 | 16 |
| P23 | P22 | P21 | P20 | P19 | P18 | P17 | P16 |
| 15 | 14 | 13 | 12 | 11 | 10 | 9 | 8 |
| P15 | P14 | P13 | P12 | P11 | P10 | P9 | P8 |
| 7 | 6 | 5 | 4 | 3 | 2 | 1 | 0 |
| P7 | P6 | P5 | P4 | P3 | P2 | P1 | P0 |

- **P0-P31: Output Data Status**

0: The data to be driven on the I/O line is 0.

1: The data to be driven on the I/O line is 1.

28.6.13 PIO Controller Pin Data Status Register

Name: PIO_PDSR

Address: 0xFFFFF43C (PIOA), 0xFFFFF63C (PIOB), 0xFFFFF83C (PIOC)

Access: Read-only

| | | | | | | | |
|-----|-----|-----|-----|-----|-----|-----|-----|
| 31 | 30 | 29 | 28 | 27 | 26 | 25 | 24 |
| P31 | P30 | P29 | P28 | P27 | P26 | P25 | P24 |
| 23 | 22 | 21 | 20 | 19 | 18 | 17 | 16 |
| P23 | P22 | P21 | P20 | P19 | P18 | P17 | P16 |
| 15 | 14 | 13 | 12 | 11 | 10 | 9 | 8 |
| P15 | P14 | P13 | P12 | P11 | P10 | P9 | P8 |
| 7 | 6 | 5 | 4 | 3 | 2 | 1 | 0 |
| P7 | P6 | P5 | P4 | P3 | P2 | P1 | P0 |

- **P0-P31: Output Data Status**

0: The I/O line is at level 0.

1: The I/O line is at level 1.

28.6.14 PIO Controller Interrupt Enable Register

Name: PIO_IER

Address: 0xFFFFF440 (PIOA), 0xFFFFF640 (PIOB), 0xFFFFF840 (PIOC)

Access: Write-only

| | | | | | | | |
|-----|-----|-----|-----|-----|-----|-----|-----|
| 31 | 30 | 29 | 28 | 27 | 26 | 25 | 24 |
| P31 | P30 | P29 | P28 | P27 | P26 | P25 | P24 |
| 23 | 22 | 21 | 20 | 19 | 18 | 17 | 16 |
| P23 | P22 | P21 | P20 | P19 | P18 | P17 | P16 |
| 15 | 14 | 13 | 12 | 11 | 10 | 9 | 8 |
| P15 | P14 | P13 | P12 | P11 | P10 | P9 | P8 |
| 7 | 6 | 5 | 4 | 3 | 2 | 1 | 0 |
| P7 | P6 | P5 | P4 | P3 | P2 | P1 | P0 |

- **P0-P31: Input Change Interrupt Enable**

0: No effect.

1: Enables the Input Change Interrupt on the I/O line.

28.6.15 PIO Controller Interrupt Disable Register

Name: PIO_IDR

Address: 0xFFFFF444 (PIOA), 0xFFFFF644 (PIOB), 0xFFFFF844 (PIOC)

Access: Write-only

| | | | | | | | |
|-----|-----|-----|-----|-----|-----|-----|-----|
| 31 | 30 | 29 | 28 | 27 | 26 | 25 | 24 |
| P31 | P30 | P29 | P28 | P27 | P26 | P25 | P24 |
| 23 | 22 | 21 | 20 | 19 | 18 | 17 | 16 |
| P23 | P22 | P21 | P20 | P19 | P18 | P17 | P16 |
| 15 | 14 | 13 | 12 | 11 | 10 | 9 | 8 |
| P15 | P14 | P13 | P12 | P11 | P10 | P9 | P8 |
| 7 | 6 | 5 | 4 | 3 | 2 | 1 | 0 |
| P7 | P6 | P5 | P4 | P3 | P2 | P1 | P0 |

- **P0-P31: Input Change Interrupt Disable**

0: No effect.

1: Disables the Input Change Interrupt on the I/O line.

28.6.16 PIO Controller Interrupt Mask Register

Name: PIO_IMR

Address: 0xFFFFF448 (PIOA), 0xFFFFF648 (PIOB), 0xFFFFF848 (PIOC)

Access: Read-only

| | | | | | | | |
|-----|-----|-----|-----|-----|-----|-----|-----|
| 31 | 30 | 29 | 28 | 27 | 26 | 25 | 24 |
| P31 | P30 | P29 | P28 | P27 | P26 | P25 | P24 |
| 23 | 22 | 21 | 20 | 19 | 18 | 17 | 16 |
| P23 | P22 | P21 | P20 | P19 | P18 | P17 | P16 |
| 15 | 14 | 13 | 12 | 11 | 10 | 9 | 8 |
| P15 | P14 | P13 | P12 | P11 | P10 | P9 | P8 |
| 7 | 6 | 5 | 4 | 3 | 2 | 1 | 0 |
| P7 | P6 | P5 | P4 | P3 | P2 | P1 | P0 |

- **P0-P31: Input Change Interrupt Mask**

0: Input Change Interrupt is disabled on the I/O line.

1: Input Change Interrupt is enabled on the I/O line.

28.6.17 PIO Controller Interrupt Status Register

Name: PIO_ISR

Address: 0xFFFFF44C (PIOA), 0xFFFFF64C (PIOB), 0xFFFFF84C (PIOC)

Access: Read-only

| | | | | | | | |
|-----|-----|-----|-----|-----|-----|-----|-----|
| 31 | 30 | 29 | 28 | 27 | 26 | 25 | 24 |
| P31 | P30 | P29 | P28 | P27 | P26 | P25 | P24 |
| 23 | 22 | 21 | 20 | 19 | 18 | 17 | 16 |
| P23 | P22 | P21 | P20 | P19 | P18 | P17 | P16 |
| 15 | 14 | 13 | 12 | 11 | 10 | 9 | 8 |
| P15 | P14 | P13 | P12 | P11 | P10 | P9 | P8 |
| 7 | 6 | 5 | 4 | 3 | 2 | 1 | 0 |
| P7 | P6 | P5 | P4 | P3 | P2 | P1 | P0 |

- **P0-P31: Input Change Interrupt Status**

0: No Input Change has been detected on the I/O line since PIO_ISR was last read or since reset.

1: At least one Input Change has been detected on the I/O line since PIO_ISR was last read or since reset.

28.6.18 PIO Multi-driver Enable Register

Name: PIO_MDER

Address: 0xFFFFF450 (PIOA), 0xFFFFF650 (PIOB), 0xFFFFF850 (PIOC)

Access: Write-only

| | | | | | | | |
|-----|-----|-----|-----|-----|-----|-----|-----|
| 31 | 30 | 29 | 28 | 27 | 26 | 25 | 24 |
| P31 | P30 | P29 | P28 | P27 | P26 | P25 | P24 |
| 23 | 22 | 21 | 20 | 19 | 18 | 17 | 16 |
| P23 | P22 | P21 | P20 | P19 | P18 | P17 | P16 |
| 15 | 14 | 13 | 12 | 11 | 10 | 9 | 8 |
| P15 | P14 | P13 | P12 | P11 | P10 | P9 | P8 |
| 7 | 6 | 5 | 4 | 3 | 2 | 1 | 0 |
| P7 | P6 | P5 | P4 | P3 | P2 | P1 | P0 |

- **P0-P31: Multi Drive Enable**

0: No effect.

1: Enables Multi Drive on the I/O line.

28.6.19 PIO Multi-driver Disable Register

Name: PIO_MDDR

Address: 0xFFFFF454 (PIOA), 0xFFFFF654 (PIOB), 0xFFFFF854 (PIOC)

Access: Write-only

| | | | | | | | |
|-----|-----|-----|-----|-----|-----|-----|-----|
| 31 | 30 | 29 | 28 | 27 | 26 | 25 | 24 |
| P31 | P30 | P29 | P28 | P27 | P26 | P25 | P24 |
| 23 | 22 | 21 | 20 | 19 | 18 | 17 | 16 |
| P23 | P22 | P21 | P20 | P19 | P18 | P17 | P16 |
| 15 | 14 | 13 | 12 | 11 | 10 | 9 | 8 |
| P15 | P14 | P13 | P12 | P11 | P10 | P9 | P8 |
| 7 | 6 | 5 | 4 | 3 | 2 | 1 | 0 |
| P7 | P6 | P5 | P4 | P3 | P2 | P1 | P0 |

- **P0-P31: Multi Drive Disable**

0: No effect.

1: Disables Multi Drive on the I/O line.

28.6.20 PIO Multi-driver Status Register

Name: PIO_MDSR

Address: 0xFFFFF458 (PIOA), 0xFFFFF658 (PIOB), 0xFFFFF858 (PIOC)

Access: Read-only

| | | | | | | | |
|-----|-----|-----|-----|-----|-----|-----|-----|
| 31 | 30 | 29 | 28 | 27 | 26 | 25 | 24 |
| P31 | P30 | P29 | P28 | P27 | P26 | P25 | P24 |
| 23 | 22 | 21 | 20 | 19 | 18 | 17 | 16 |
| P23 | P22 | P21 | P20 | P19 | P18 | P17 | P16 |
| 15 | 14 | 13 | 12 | 11 | 10 | 9 | 8 |
| P15 | P14 | P13 | P12 | P11 | P10 | P9 | P8 |
| 7 | 6 | 5 | 4 | 3 | 2 | 1 | 0 |
| P7 | P6 | P5 | P4 | P3 | P2 | P1 | P0 |

- **P0-P31: Multi Drive Status**

0: The Multi Drive is disabled on the I/O line. The pin is driven at high and low level.

1: The Multi Drive is enabled on the I/O line. The pin is driven at low level only.

28.6.21 PIO Pull Up Disable Register

Name: PIO_PUDR

Address: 0xFFFFF460 (PIOA), 0xFFFFF660 (PIOB), 0xFFFFF860 (PIOC)

Access: Write-only

| | | | | | | | |
|-----|-----|-----|-----|-----|-----|-----|-----|
| 31 | 30 | 29 | 28 | 27 | 26 | 25 | 24 |
| P31 | P30 | P29 | P28 | P27 | P26 | P25 | P24 |
| 23 | 22 | 21 | 20 | 19 | 18 | 17 | 16 |
| P23 | P22 | P21 | P20 | P19 | P18 | P17 | P16 |
| 15 | 14 | 13 | 12 | 11 | 10 | 9 | 8 |
| P15 | P14 | P13 | P12 | P11 | P10 | P9 | P8 |
| 7 | 6 | 5 | 4 | 3 | 2 | 1 | 0 |
| P7 | P6 | P5 | P4 | P3 | P2 | P1 | P0 |

- **P0-P31: Pull Up Disable**

0: No effect.

1: Disables the pull up resistor on the I/O line.

28.6.22 PIO Pull Up Enable Register

Name: PIO_PUER

Address: 0xFFFFF464 (PIOA), 0xFFFFF664 (PIOB), 0xFFFFF864 (PIOC)

Access: Write-only

| | | | | | | | |
|-----|-----|-----|-----|-----|-----|-----|-----|
| 31 | 30 | 29 | 28 | 27 | 26 | 25 | 24 |
| P31 | P30 | P29 | P28 | P27 | P26 | P25 | P24 |
| 23 | 22 | 21 | 20 | 19 | 18 | 17 | 16 |
| P23 | P22 | P21 | P20 | P19 | P18 | P17 | P16 |
| 15 | 14 | 13 | 12 | 11 | 10 | 9 | 8 |
| P15 | P14 | P13 | P12 | P11 | P10 | P9 | P8 |
| 7 | 6 | 5 | 4 | 3 | 2 | 1 | 0 |
| P7 | P6 | P5 | P4 | P3 | P2 | P1 | P0 |

- **P0-P31: Pull Up Enable**

0: No effect.

1: Enables the pull up resistor on the I/O line.

28.6.23 PIO Pull Up Status Register

Name: PIO_PUSR

Address: 0xFFFFF468 (PIOA), 0xFFFFF668 (PIOB), 0xFFFFF868 (PIOC)

Access: Read-only

| | | | | | | | |
|-----|-----|-----|-----|-----|-----|-----|-----|
| 31 | 30 | 29 | 28 | 27 | 26 | 25 | 24 |
| P31 | P30 | P29 | P28 | P27 | P26 | P25 | P24 |
| 23 | 22 | 21 | 20 | 19 | 18 | 17 | 16 |
| P23 | P22 | P21 | P20 | P19 | P18 | P17 | P16 |
| 15 | 14 | 13 | 12 | 11 | 10 | 9 | 8 |
| P15 | P14 | P13 | P12 | P11 | P10 | P9 | P8 |
| 7 | 6 | 5 | 4 | 3 | 2 | 1 | 0 |
| P7 | P6 | P5 | P4 | P3 | P2 | P1 | P0 |

- **P0-P31: Pull Up Status**

0: Pull Up resistor is enabled on the I/O line.

1: Pull Up resistor is disabled on the I/O line.

28.6.24 PIO Peripheral A Select Register

Name: PIO_ASR

Address: 0xFFFFF470 (PIOA), 0xFFFFF670 (PIOB), 0xFFFFF870 (PIOC)

Access: Write-only

| | | | | | | | |
|-----|-----|-----|-----|-----|-----|-----|-----|
| 31 | 30 | 29 | 28 | 27 | 26 | 25 | 24 |
| P31 | P30 | P29 | P28 | P27 | P26 | P25 | P24 |
| 23 | 22 | 21 | 20 | 19 | 18 | 17 | 16 |
| P23 | P22 | P21 | P20 | P19 | P18 | P17 | P16 |
| 15 | 14 | 13 | 12 | 11 | 10 | 9 | 8 |
| P15 | P14 | P13 | P12 | P11 | P10 | P9 | P8 |
| 7 | 6 | 5 | 4 | 3 | 2 | 1 | 0 |
| P7 | P6 | P5 | P4 | P3 | P2 | P1 | P0 |

- **P0-P31: Peripheral A Select**

0: No effect.

1: Assigns the I/O line to the Peripheral A function.

28.6.25 PIO Peripheral B Select Register

Name: PIO_BSR

Address: 0xFFFFF474 (PIOA), 0xFFFFF674 (PIOB), 0xFFFFF874 (PIOC)

Access: Write-only

| | | | | | | | |
|-----|-----|-----|-----|-----|-----|-----|-----|
| 31 | 30 | 29 | 28 | 27 | 26 | 25 | 24 |
| P31 | P30 | P29 | P28 | P27 | P26 | P25 | P24 |
| 23 | 22 | 21 | 20 | 19 | 18 | 17 | 16 |
| P23 | P22 | P21 | P20 | P19 | P18 | P17 | P16 |
| 15 | 14 | 13 | 12 | 11 | 10 | 9 | 8 |
| P15 | P14 | P13 | P12 | P11 | P10 | P9 | P8 |
| 7 | 6 | 5 | 4 | 3 | 2 | 1 | 0 |
| P7 | P6 | P5 | P4 | P3 | P2 | P1 | P0 |

- **P0-P31: Peripheral B Select**

0: No effect.

1: Assigns the I/O line to the peripheral B function.

28.6.26 PIO Peripheral A B Status Register

Name: PIO_ABSR

Address: 0xFFFFF478 (PIOA), 0xFFFFF678 (PIOB), 0xFFFFF878 (PIOC)

Access: Read-only

| | | | | | | | |
|-----|-----|-----|-----|-----|-----|-----|-----|
| 31 | 30 | 29 | 28 | 27 | 26 | 25 | 24 |
| P31 | P30 | P29 | P28 | P27 | P26 | P25 | P24 |
| 23 | 22 | 21 | 20 | 19 | 18 | 17 | 16 |
| P23 | P22 | P21 | P20 | P19 | P18 | P17 | P16 |
| 15 | 14 | 13 | 12 | 11 | 10 | 9 | 8 |
| P15 | P14 | P13 | P12 | P11 | P10 | P9 | P8 |
| 7 | 6 | 5 | 4 | 3 | 2 | 1 | 0 |
| P7 | P6 | P5 | P4 | P3 | P2 | P1 | P0 |

- **P0-P31: Peripheral A B Status**

0: The I/O line is assigned to the Peripheral A.

1: The I/O line is assigned to the Peripheral B.

28.6.27 PIO Output Write Enable Register

Name: PIO_OWER

Address: 0xFFFFF4A0 (PIOA), 0xFFFFF6A0 (PIOB), 0xFFFFF8A0 (PIOC)

Access: Write-only

| | | | | | | | |
|-----|-----|-----|-----|-----|-----|-----|-----|
| 31 | 30 | 29 | 28 | 27 | 26 | 25 | 24 |
| P31 | P30 | P29 | P28 | P27 | P26 | P25 | P24 |
| 23 | 22 | 21 | 20 | 19 | 18 | 17 | 16 |
| P23 | P22 | P21 | P20 | P19 | P18 | P17 | P16 |
| 15 | 14 | 13 | 12 | 11 | 10 | 9 | 8 |
| P15 | P14 | P13 | P12 | P11 | P10 | P9 | P8 |
| 7 | 6 | 5 | 4 | 3 | 2 | 1 | 0 |
| P7 | P6 | P5 | P4 | P3 | P2 | P1 | P0 |

- **P0-P31: Output Write Enable**

0: No effect.

1: Enables writing PIO_ODSR for the I/O line.

28.6.28 PIO Output Write Disable Register

Name: PIO_OWDR

Address: 0xFFFFF4A4 (PIOA), 0xFFFFF6A4 (PIOB), 0xFFFFF8A4 (PIOC)

Access: Write-only

| | | | | | | | |
|-----|-----|-----|-----|-----|-----|-----|-----|
| 31 | 30 | 29 | 28 | 27 | 26 | 25 | 24 |
| P31 | P30 | P29 | P28 | P27 | P26 | P25 | P24 |
| 23 | 22 | 21 | 20 | 19 | 18 | 17 | 16 |
| P23 | P22 | P21 | P20 | P19 | P18 | P17 | P16 |
| 15 | 14 | 13 | 12 | 11 | 10 | 9 | 8 |
| P15 | P14 | P13 | P12 | P11 | P10 | P9 | P8 |
| 7 | 6 | 5 | 4 | 3 | 2 | 1 | 0 |
| P7 | P6 | P5 | P4 | P3 | P2 | P1 | P0 |

- **P0-P31: Output Write Disable**

0: No effect.

1: Disables writing PIO_ODSR for the I/O line.

28.6.29 PIO Output Write Status Register

Name: PIO_OWSR

Address: 0xFFFFF4A8 (PIOA), 0xFFFFF6A8 (PIOB), 0xFFFFF8A8 (PIOC)

Access: Read-only

| | | | | | | | |
|-----|-----|-----|-----|-----|-----|-----|-----|
| 31 | 30 | 29 | 28 | 27 | 26 | 25 | 24 |
| P31 | P30 | P29 | P28 | P27 | P26 | P25 | P24 |
| 23 | 22 | 21 | 20 | 19 | 18 | 17 | 16 |
| P23 | P22 | P21 | P20 | P19 | P18 | P17 | P16 |
| 15 | 14 | 13 | 12 | 11 | 10 | 9 | 8 |
| P15 | P14 | P13 | P12 | P11 | P10 | P9 | P8 |
| 7 | 6 | 5 | 4 | 3 | 2 | 1 | 0 |
| P7 | P6 | P5 | P4 | P3 | P2 | P1 | P0 |

- **P0-P31: Output Write Status**

0: Writing PIO_ODSR does not affect the I/O line.

1: Writing PIO_ODSR affects the I/O line.

29. Serial Peripheral Interface (SPI)

29.1 Overview

The Serial Peripheral Interface (SPI) circuit is a synchronous serial data link that provides communication with external devices in Master or Slave Mode. It also enables communication between processors if an external processor is connected to the system.

The Serial Peripheral Interface is essentially a shift register that serially transmits data bits to other SPIs. During a data transfer, one SPI system acts as the “master” which controls the data flow, while the other devices act as “slaves” which have data shifted into and out by the master. Different CPUs can take turn being masters (Multiple Master Protocol opposite to Single Master Protocol where one CPU is always the master while all of the others are always slaves) and one master may simultaneously shift data into multiple slaves. However, only one slave may drive its output to write data back to the master at any given time.

A slave device is selected when the master asserts its NSS signal. If multiple slave devices exist, the master generates a separate slave select signal for each slave (NPCS).

The SPI system consists of two data lines and two control lines:

- Master Out Slave In (MOSI): This data line supplies the output data from the master shifted into the input(s) of the slave(s).
- Master In Slave Out (MISO): This data line supplies the output data from a slave to the input of the master. There may be no more than one slave transmitting data during any particular transfer.
- Serial Clock (SPCK): This control line is driven by the master and regulates the flow of the data bits. The master may transmit data at a variety of baud rates; the SPCK line cycles once for each bit that is transmitted.
- Slave Select (NSS): This control line allows slaves to be turned on and off by hardware.

29.2 Block Diagram

Figure 29-1. Block Diagram

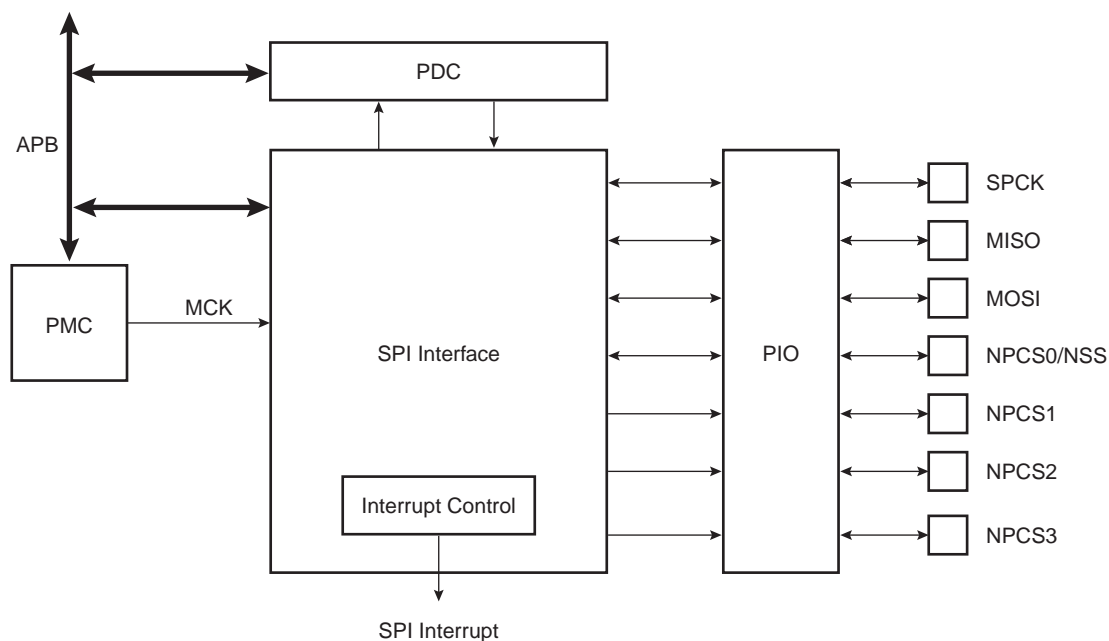

29.3 Application Block Diagram

Figure 29-2. Application Block Diagram: Single Master/Multiple Slave Implementation

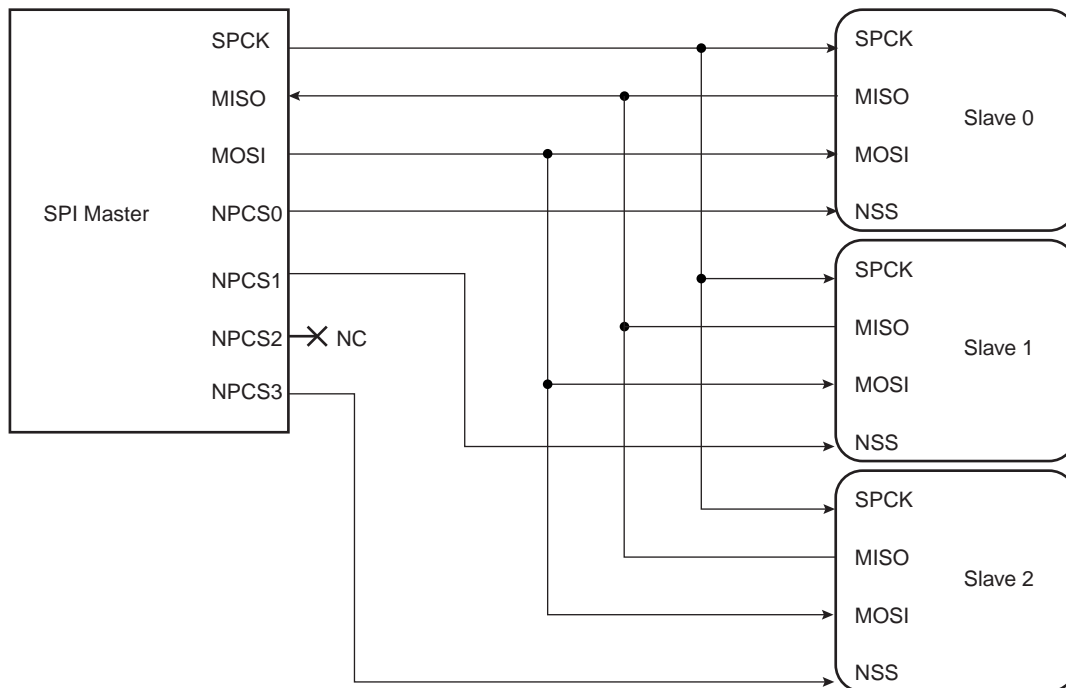

29.4 Signal Description

Table 29-1. Signal Description

| Pin Name | Pin Description | Type | |
|-------------|-------------------------------------|--------|--------|
| | | Master | Slave |
| MISO | Master In Slave Out | Input | Output |
| MOSI | Master Out Slave In | Output | Input |
| SPCK | Serial Clock | Output | Input |
| NPCS1-NPCS3 | Peripheral Chip Selects | Output | Unused |
| NPCS0/NSS | Peripheral Chip Select/Slave Select | Output | Input |

29.5 Product Dependencies

29.5.1 I/O Lines

The pins used for interfacing the compliant external devices may be multiplexed with PIO lines. The programmer must first program the PIO controllers to assign the SPI pins to their peripheral functions.

29.5.2 Power Management

The SPI may be clocked through the Power Management Controller (PMC), thus the programmer must first configure the PMC to enable the SPI clock.

29.5.3 Interrupt

The SPI interface has an interrupt line connected to the Advanced Interrupt Controller (AIC). Handling the SPI interrupt requires programming the AIC before configuring the SPI.

29.6 Functional Description

29.6.1 Modes of Operation

The SPI operates in Master Mode or in Slave Mode.

Operation in Master Mode is programmed by writing at 1 the MSTR bit in the Mode Register. The pins NPCS0 to NPCS3 are all configured as outputs, the SPCK pin is driven, the MISO line is wired on the receiver input and the MOSI line driven as an output by the transmitter.

If the MSTR bit is written at 0, the SPI operates in Slave Mode. The MISO line is driven by the transmitter output, the MOSI line is wired on the receiver input, the SPCK pin is driven by the transmitter to synchronize the receiver. The NPCS0 pin becomes an input, and is used as a Slave Select signal (NSS). The pins NPCS1 to NPCS3 are not driven and can be used for other purposes.

The data transfers are identically programmable for both modes of operations. The baud rate generator is activated only in Master Mode.

29.6.2 Data Transfer

Four combinations of polarity and phase are available for data transfers. The clock polarity is programmed with the CPOL bit in the Chip Select Register. The clock phase is programmed with the NCPHA bit. These two parameters determine the edges of the clock signal on which data is driven and sampled. Each of the two parameters has two possible states, resulting in four possible combinations that are incompatible with one another. Thus, a master/slave pair must use the same parameter pair values to communicate. If multiple slaves are used and fixed in different configurations, the master must reconfigure itself each time it needs to communicate with a different slave.

[Table 29-2](#) shows the four modes and corresponding parameter settings.

Table 29-2. SPI Bus Protocol Mode

| SPI Mode | CPOL | NCPHA |
|----------|------|-------|
| 0 | 0 | 1 |
| 1 | 0 | 0 |
| 2 | 1 | 1 |
| 3 | 1 | 0 |

[Figure 29-3](#) and [Figure 29-4](#) show examples of data transfers.

Figure 29-3. SPI Transfer Format (NCPHA = 1, 8 bits per transfer)

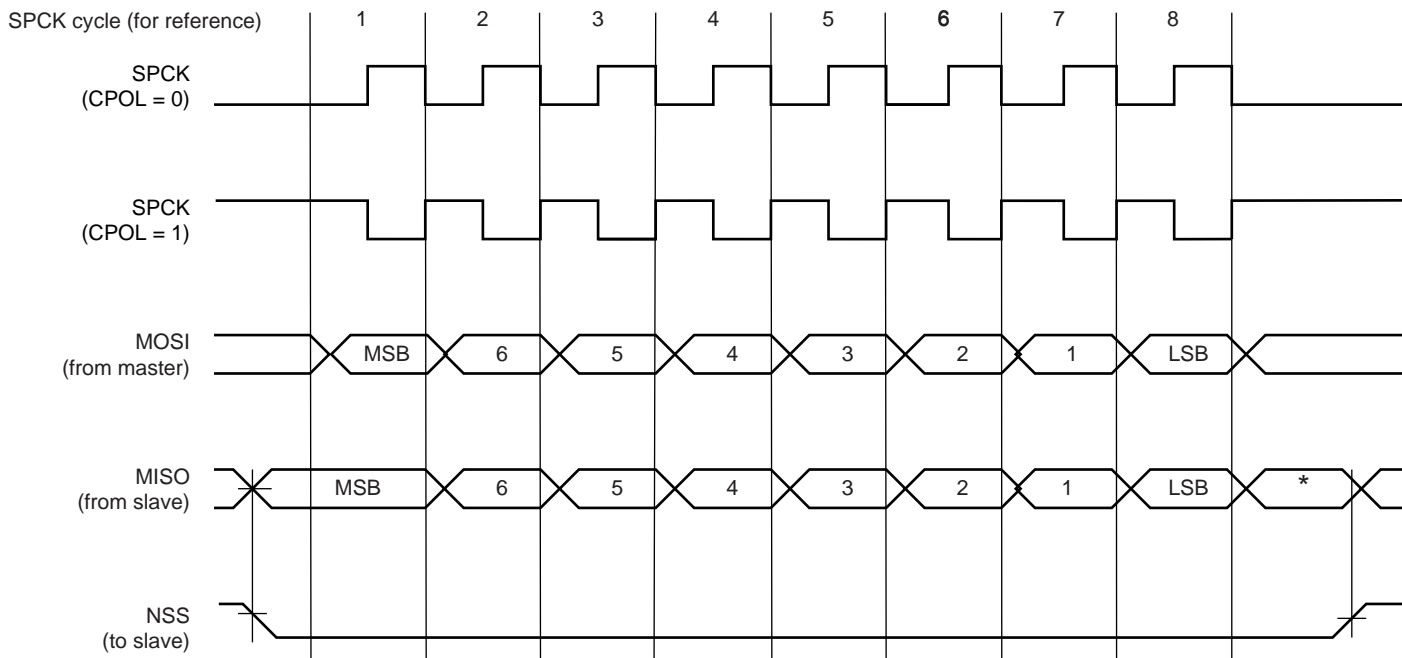

* Not defined, but normally MSB of previous character received.

Figure 29-4. SPI Transfer Format (NCPHA = 0, 8 bits per transfer)

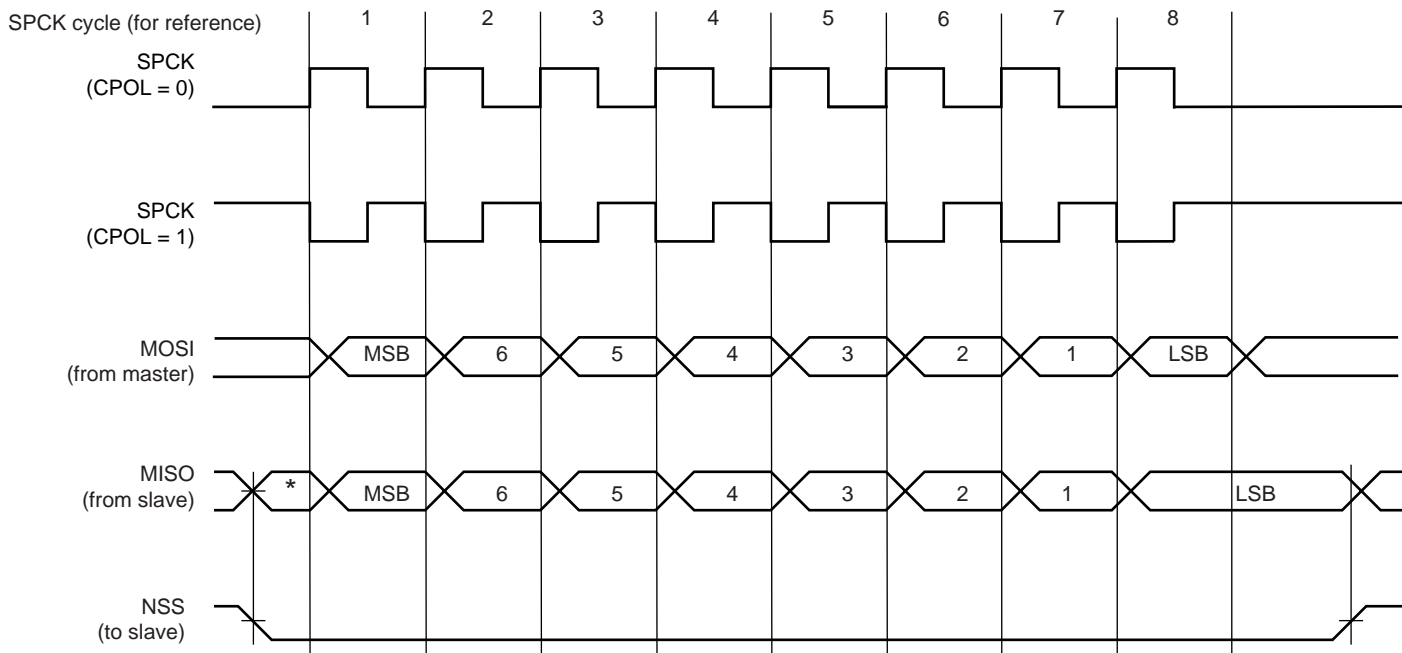

* Not defined but normally LSB of previous character transmitted.

29.6.3 Master Mode Operations

When configured in Master Mode, the SPI operates on the clock generated by the internal programmable baud rate generator. It fully controls the data transfers to and from the slave(s) connected to the SPI bus. The SPI drives the chip select line to the slave and the serial clock signal (SPCK).

The SPI features two holding registers, the Transmit Data Register and the Receive Data Register, and a single Shift Register. The holding registers maintain the data flow at a constant rate.

After enabling the SPI, a data transfer begins when the processor writes to the SPI_TDR (Transmit Data Register). The written data is immediately transferred in the Shift Register and transfer on the SPI bus starts. While the data in the Shift Register is shifted on the MOSI line, the MISO line is sampled and shifted in the Shift Register. Transmission cannot occur without reception.

Before writing the TDR, the PCS field must be set in order to select a slave.

If new data is written in SPI_TDR during the transfer, it stays in it until the current transfer is completed. Then, the received data is transferred from the Shift Register to SPI_RDR, the data in SPI_TDR is loaded in the Shift Register and a new transfer starts.

The transfer of a data written in SPI_TDR in the Shift Register is indicated by the TDRE bit (Transmit Data Register Empty) in the Status Register (SPI_SR). When new data is written in SPI_TDR, this bit is cleared. The TDRE bit is used to trigger the Transmit PDC channel.

The end of transfer is indicated by the TXEMPTY flag in the SPI_SR. If a transfer delay (DLYBCT) is greater than 0 for the last transfer, TXEMPTY is set after the completion of said delay. The master clock (MCK) can be switched off at this time.

The transfer of received data from the Shift Register in SPI_RDR is indicated by the RDRF bit (Receive Data Register Full) in the Status Register (SPI_SR). When the received data is read, the RDRF bit is cleared.

If the SPI_RDR (Receive Data Register) has not been read before new data is received, the Overrun Error bit (OVRES) in SPI_SR is set. As long as this flag is set, data is loaded in SPI_RDR. The user has to read the status register to clear the OVRES bit.

[Figure 29-5](#) shows a block diagram of the SPI when operating in Master Mode. [Figure 29-6 on page 372](#) shows a flow chart describing how transfers are handled.

29.6.3.1 Master Mode Block Diagram

Figure 29-5. Master Mode Block Diagram

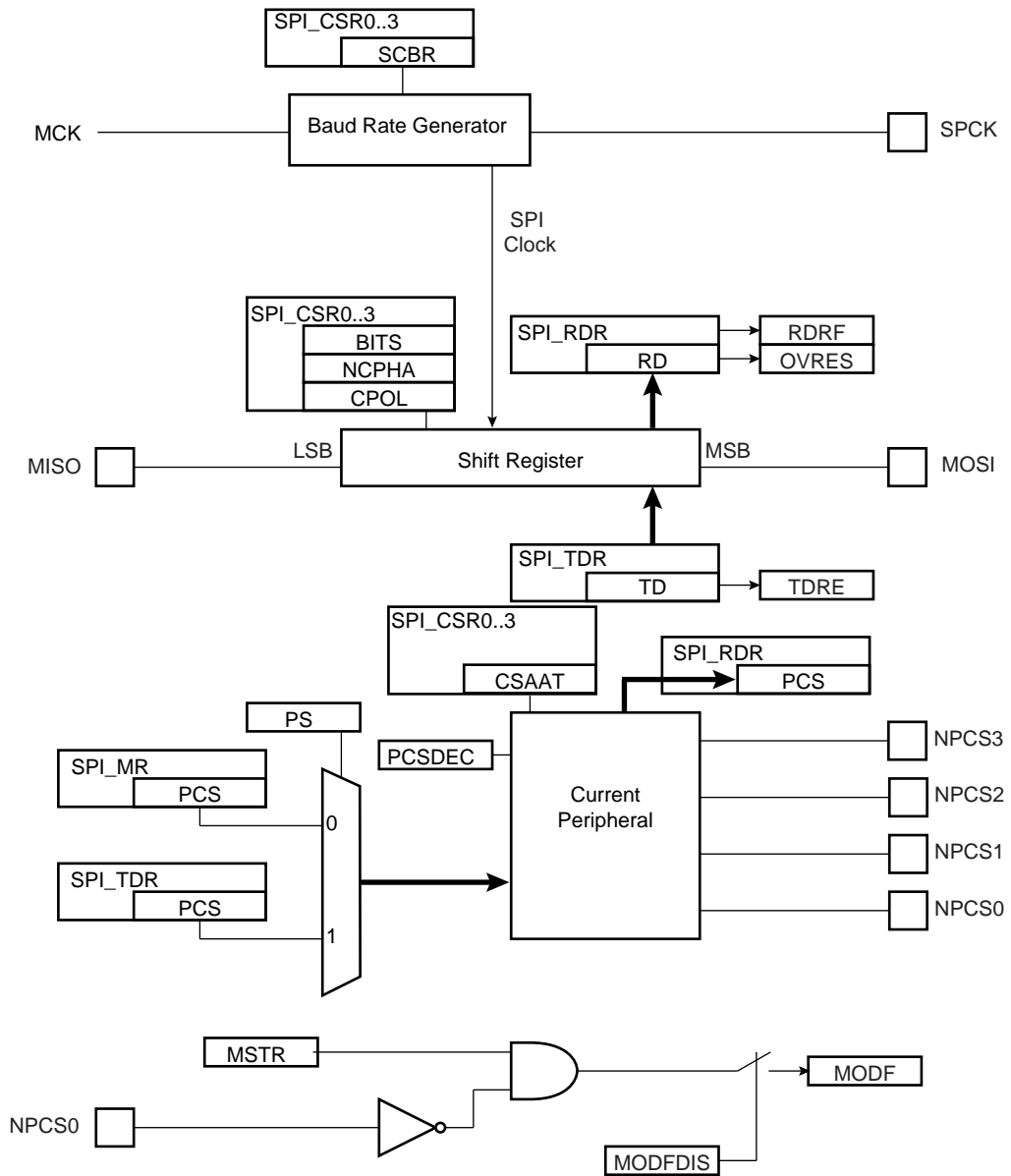

29.6.3.2 Master Mode Flow Diagram

Figure 29-6. Master Mode Flow Diagram

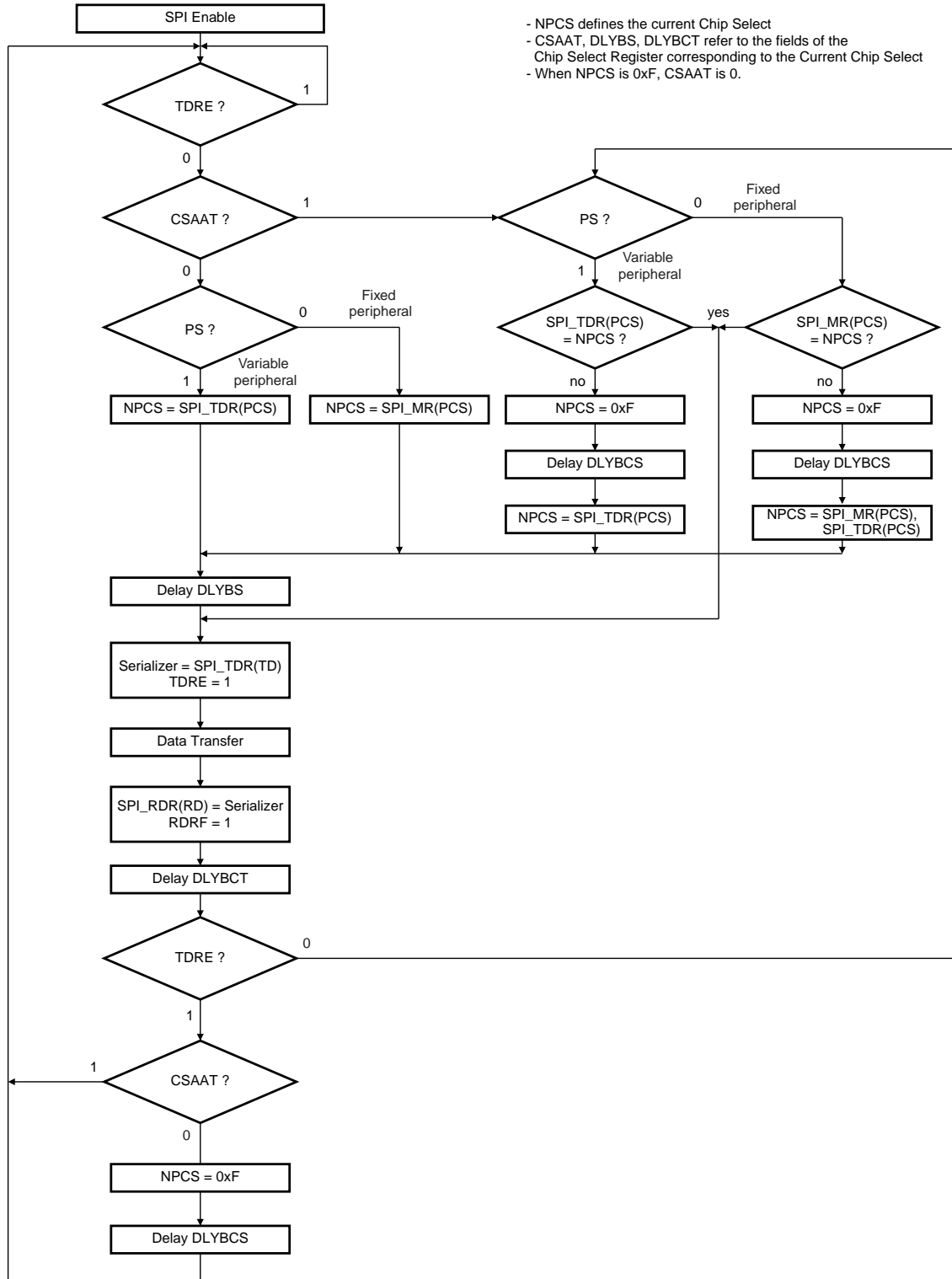

29.6.3.3 Clock Generation

The SPI baud rate clock is generated by dividing the Master Clock (MCK), by a value between 1 and 255.

This allows a maximum operating baud rate at up to Master Clock and a minimum operating baud rate of MCK divided by 255.

Programming the SCBR field at 0 is forbidden. Triggering a transfer while SCBR is at 0 can lead to unpredictable results.

At reset, SCBR is 0 and the user has to program it at a valid value before performing the first transfer.

The divisor can be defined independently for each chip select, as it has to be programmed in the SCBR field of the Chip Select Registers. This allows the SPI to automatically adapt the baud rate for each interfaced peripheral without reprogramming.

29.6.3.4 Transfer Delays

Figure 29-7 shows a chip select transfer change and consecutive transfers on the same chip select. Three delays can be programmed to modify the transfer waveforms:

- The delay between chip selects, programmable only once for all the chip selects by writing the DLYBCS field in the Mode Register. Allows insertion of a delay between release of one chip select and before assertion of a new one.
- The delay before SPCK, independently programmable for each chip select by writing the field DLYBS. Allows the start of SPCK to be delayed after the chip select has been asserted.
- The delay between consecutive transfers, independently programmable for each chip select by writing the DLYBCT field. Allows insertion of a delay between two transfers occurring on the same chip select

These delays allow the SPI to be adapted to the interfaced peripherals and their speed and bus release time.

Figure 29-7. Programmable Delays

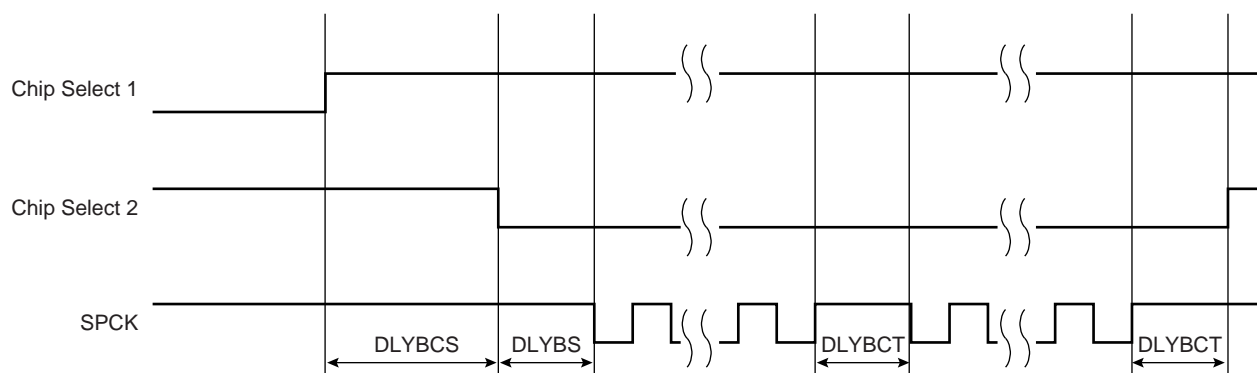

29.6.3.5 Peripheral Selection

The serial peripherals are selected through the assertion of the NPCS0 to NPCS3 signals. By default, all the NPCS signals are high before and after each transfer.

The peripheral selection can be performed in two different ways:

- Fixed Peripheral Select: SPI exchanges data with only one peripheral
- Variable Peripheral Select: Data can be exchanged with more than one peripheral

Fixed Peripheral Select is activated by writing the PS bit to zero in SPI_MR (Mode Register). In this case, the current peripheral is defined by the PCS field in SPI_MR and the PCS field in the SPI_TDR has no effect.

Variable Peripheral Select is activated by setting PS bit to one. The PCS field in SPI_TDR is used to select the current peripheral. This means that the peripheral selection can be defined for each new data.

The Fixed Peripheral Selection allows buffer transfers with a single peripheral. Using the PDC is an optimal means, as the size of the data transfer between the memory and the SPI is either 8 bits or 16 bits. However, changing the peripheral selection requires the Mode Register to be reprogrammed.

The Variable Peripheral Selection allows buffer transfers with multiple peripherals without reprogramming the Mode Register. Data written in SPI_TDR is 32 bits wide and defines the real data to be transmitted and the peripheral it is destined to. Using the PDC in this mode requires 32-bit wide buffers, with the data in the Lisps and the PCS and LASTXFER fields in the MSBs, however the SPI still controls the number of bits (8 to 16) to be transferred through MISO and MOSI lines with the chip select configuration registers. This is not the optimal means in terms of memory size for the buffers, but it provides a very effective means to exchange data with several peripherals without any intervention of the processor.

29.6.3.6 Peripheral Chip Select Decoding

The user can program the SPI to operate with up to 15 peripherals by decoding the four Chip Select lines, NPCS0 to NPCS3 with an external logic. This can be enabled by writing the PCSDEC bit at 1 in the Mode Register (SPI_MR).

When operating without decoding, the SPI makes sure that in any case only one chip select line is activated, i.e. driven low at a time. If two bits are defined low in a PCS field, only the lowest numbered chip select is driven low.

When operating with decoding, the SPI directly outputs the value defined by the PCS field of either the Mode Register or the Transmit Data Register (depending on PS).

As the SPI sets a default value of 0xF on the chip select lines (i.e. all chip select lines at 1) when not processing any transfer, only 15 peripherals can be decoded.

The SPI has only four Chip Select Registers, not 15. As a result, when decoding is activated, each chip select defines the characteristics of up to four peripherals. As an example, SPI_CR0 defines the characteristics of the externally decoded peripherals 0 to 3, corresponding to the PCS values 0x0 to 0x3. Thus, the user has to make sure to connect compatible peripherals on the decoded chip select lines 0 to 3, 4 to 7, 8 to 11 and 12 to 14.

29.6.3.7 Peripheral Deselection

When operating normally, as soon as the transfer of the last data written in SPI_TDR is completed, the NPCS lines all rise. This might lead to runtime error if the processor is too long in responding to an interrupt, and thus might lead to difficulties for interfacing with some serial peripherals requiring the chip select line to remain active during a full set of transfers.

To facilitate interfacing with such devices, the Chip Select Register can be programmed with the CSAAT bit (Chip Select Active After Transfer) at 1. This allows the chip select lines to remain in their current state (low = active) until transfer to another peripheral is required.

[Figure 29-8](#) shows different peripheral deselection cases and the effect of the CSAAT bit.

Figure 29-8. Peripheral Deselection

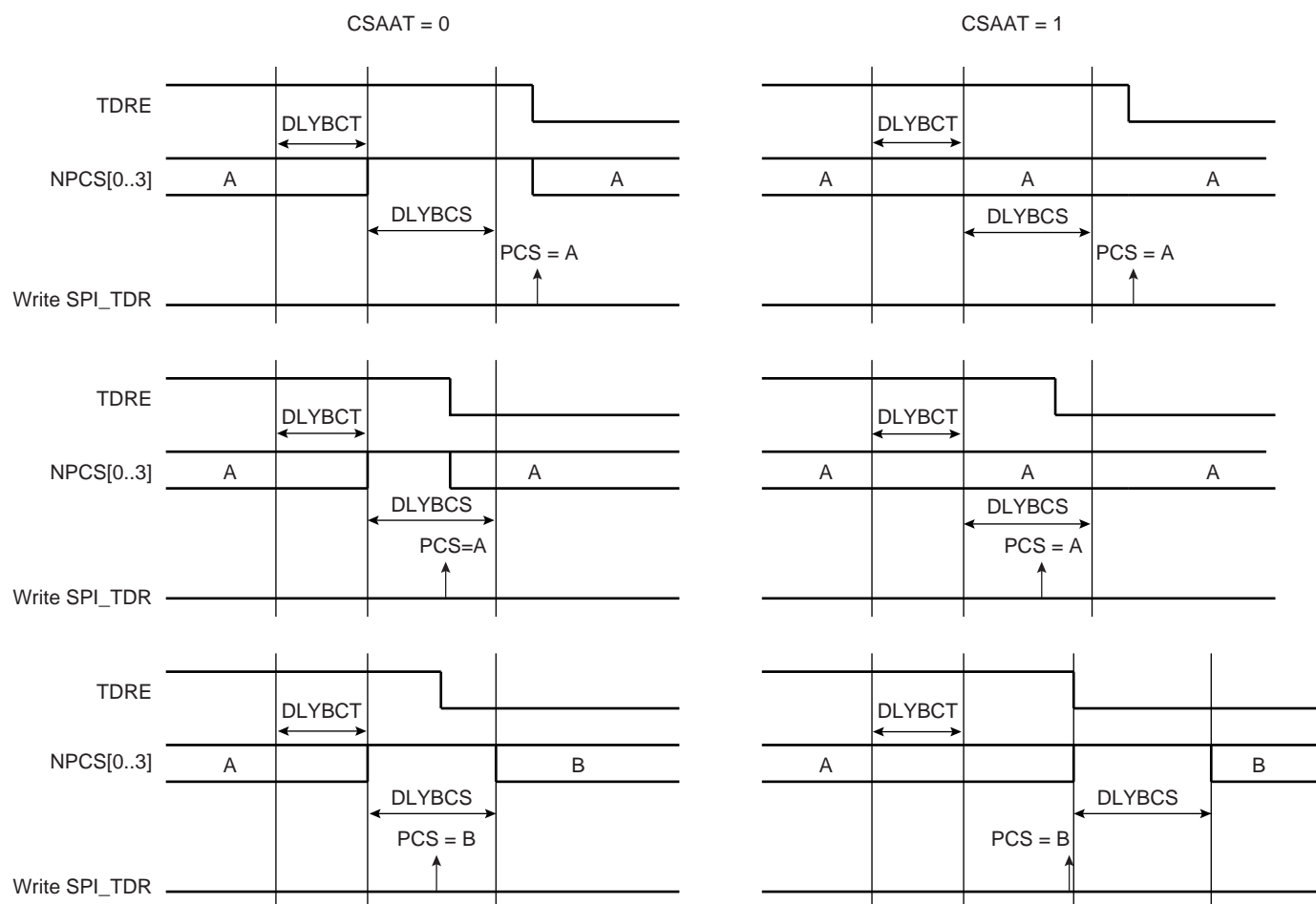

29.6.3.8 Mode Fault Detection

A mode fault is detected when the SPI is programmed in Master Mode and a low level is driven by an external master on the NPCS0/NSS signal. NPCS0, MOSI, MISO and SPCK must be configured in open drain through the PIO controller, so that external pull up resistors are needed to guarantee high level.

When a mode fault is detected, the MODF bit in the SPI_SR is set until the SPI_SR is read and the SPI is automatically disabled until re-enabled by writing the SPIEN bit in the SPI_CR (Control Register) at 1.

By default, the Mode Fault detection circuitry is enabled. The user can disable Mode Fault detection by setting the MODFDIS bit in the SPI Mode Register (SPI_MR).

29.6.4 SPI Slave Mode

When operating in Slave Mode, the SPI processes data bits on the clock provided on the SPI clock pin (SPCK).

The SPI waits for NSS to go active before receiving the serial clock from an external master. When NSS falls, the clock is validated on the serializer, which processes the number of bits defined by the BITS field of the Chip Select Register 0 (SPI_CSR0). These bits are processed following a phase and a polarity defined respectively by the NCPHA and CPOL bits of the SPI_CSR0. Note that BITS, CPOL and NCPHA of the other Chip Select Registers have no effect when the SPI is programmed in Slave Mode.

The bits are shifted out on the MISO line and sampled on the MOSI line.

(For more information on the BITS field, see also the note below the SPI_CSRx bitmap ([Section 29.7.9 "SPI Chip Select Register"](#))).

When all the bits are processed, the received data is transferred in the Receive Data Register and the RDRF bit rises. If the SPI_RDR (Receive Data Register) has not been read before new data is received, the Overrun Error bit (OVRES) in SPI_SR is set. As long as this flag is set, data is loaded in SPI_RDR. The user has to read the status register to clear the OVRES bit.

When a transfer starts, the data shifted out is the data present in the Shift Register. If no data has been written in the Transmit Data Register (SPI_TDR), the last data received is transferred. If no data has been received since the last reset, all bits are transmitted low, as the Shift Register resets at 0.

When a first data is written in SPI_TDR, it is transferred immediately in the Shift Register and the TDRE bit rises. If new data is written, it remains in SPI_TDR until a transfer occurs, i.e. NSS falls and there is a valid clock on the SPCK pin. When the transfer occurs, the last data written in SPI_TDR is transferred in the Shift Register and the TDRE bit rises. This enables frequent updates of critical variables with single transfers.

Then, a new data is loaded in the Shift Register from the Transmit Data Register. In case no character is ready to be transmitted, i.e. no character has been written in SPI_TDR since the last load from SPI_TDR to the Shift Register, the Shift Register is not modified and the last received character is retransmitted.

Figure 29-9 shows a block diagram of the SPI when operating in Slave Mode.

Figure 29-9. Slave Mode Functional Bloc Diagram

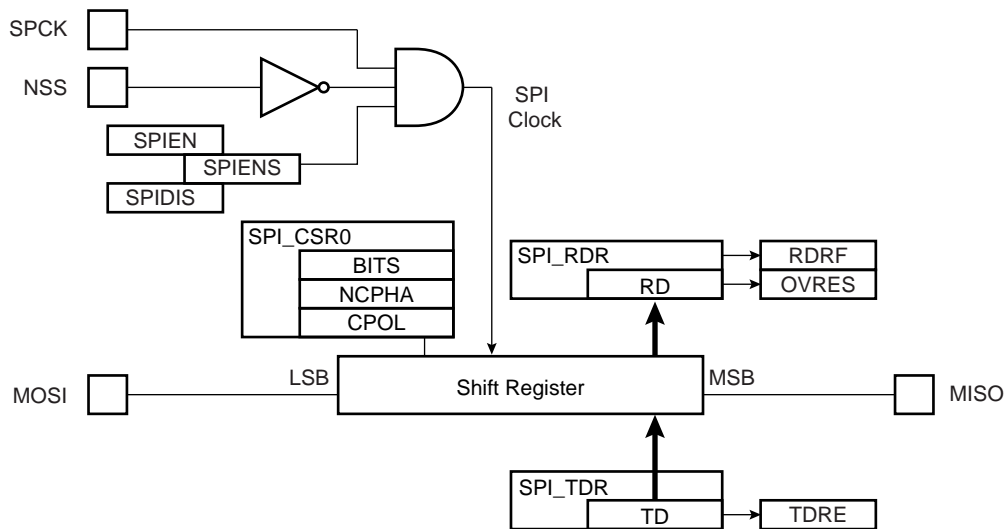

29.7 Serial Peripheral Interface (SPI) User Interface

Table 29-3. Register Mapping

| Offset | Register | Name | Access | Reset |
|---------------|----------------------------|----------|------------|------------|
| 0x00 | Control Register | SPI_CR | Write-only | – |
| 0x04 | Mode Register | SPI_MR | Read/Write | 0x0 |
| 0x08 | Receive Data Register | SPI_RDR | Read-only | 0x0 |
| 0x0C | Transmit Data Register | SPI_TDR | Write-only | – |
| 0x10 | Status Register | SPI_SR | Read-only | 0x000000F0 |
| 0x14 | Interrupt Enable Register | SPI_IER | Write-only | – |
| 0x18 | Interrupt Disable Register | SPI_IDR | Write-only | – |
| 0x1C | Interrupt Mask Register | SPI_IMR | Read-only | 0x0 |
| 0x20–0x2C | Reserved | – | – | – |
| 0x30 | Chip Select Register 0 | SPI_CSR0 | Read/Write | 0x0 |
| 0x34 | Chip Select Register 1 | SPI_CSR1 | Read/Write | 0x0 |
| 0x38 | Chip Select Register 2 | SPI_CSR2 | Read/Write | 0x0 |
| 0x3C | Chip Select Register 3 | SPI_CSR3 | Read/Write | 0x0 |
| 0x004C–0x00F8 | Reserved | – | – | – |
| 0x004C–0x00FC | Reserved | – | – | – |
| 0x100–0x124 | Reserved for the PDC | – | – | – |

29.7.1 SPI Control Register

Name: SPI_CR

Address: 0xFFFFC8000 (0), 0xFFFFCC000 (1)

Access: Write-only

| | | | | | | | |
|-------|----|----|----|----|----|--------|----------|
| 31 | 30 | 29 | 28 | 27 | 26 | 25 | 24 |
| – | – | – | – | – | – | – | LASTXFER |
| 23 | 22 | 21 | 20 | 19 | 18 | 17 | 16 |
| – | – | – | – | – | – | – | – |
| 15 | 14 | 13 | 12 | 11 | 10 | 9 | 8 |
| – | – | – | – | – | – | – | – |
| 7 | 6 | 5 | 4 | 3 | 2 | 1 | 0 |
| SWRST | – | – | – | – | – | SPIDIS | SPIEN |

- **SPIEN: SPI Enable**

0: No effect.

1: Enables the SPI to transfer and receive data.

- **SPIDIS: SPI Disable**

0: No effect.

1: Disables the SPI.

As soon as SPIDIS is set, SPI finishes its transfer.

All pins are set in input mode and no data is received or transmitted.

If a transfer is in progress, the transfer is finished before the SPI is disabled.

If both SPIEN and SPIDIS are equal to one when the control register is written, the SPI is disabled.

- **SWRST: SPI Software Reset**

0: No effect.

1: Reset the SPI. A software-triggered hardware reset of the SPI interface is performed.

The SPI is in slave mode after software reset.

PDC channels are not affected by software reset.

- **LASTXFER: Last Transfer**

0: No effect.

1: The current NPCS will be deasserted after the character written in TD has been transferred. When CSAAT is set, this allows to close the communication with the current serial peripheral by raising the corresponding NPCS line as soon as TD transfer has completed.

29.7.2 SPI Mode Register

Name: SPI_MR

Address: 0xFFFC8004 (0), 0xFFFC004 (1)

Access: Read/Write

| | | | | | | | |
|--------|----|----|---------|-----|--------|----|------|
| 31 | 30 | 29 | 28 | 27 | 26 | 25 | 24 |
| DLYBCS | | | | | | | |
| 23 | 22 | 21 | 20 | 19 | 18 | 17 | 16 |
| – | – | – | – | PCS | | | |
| 15 | 14 | 13 | 12 | 11 | 10 | 9 | 8 |
| – | – | – | – | – | – | – | – |
| 7 | 6 | 5 | 4 | 3 | 2 | 1 | 0 |
| LLB | – | – | MODFDIS | – | PCSDEC | PS | MSTR |

- **MSTR: Master/Slave Mode**

0: SPI is in Slave mode.

1: SPI is in Master mode.

- **PS: Peripheral Select**

0: Fixed Peripheral Select.

1: Variable Peripheral Select.

- **PCSDEC: Chip Select Decode**

0: The chip selects are directly connected to a peripheral device.

1: The four chip select lines are connected to a 4- to 16-bit decoder.

When PCSDEC equals one, up to 15 Chip Select signals can be generated with the four lines using an external 4- to 16-bit decoder. The Chip Select Registers define the characteristics of the 15 chip selects according to the following rules:

SPI_CSR0 defines peripheral chip select signals 0 to 3.

SPI_CSR1 defines peripheral chip select signals 4 to 7.

SPI_CSR2 defines peripheral chip select signals 8 to 11.

SPI_CSR3 defines peripheral chip select signals 12 to 14.

- **MODFDIS: Mode Fault Detection**

0: Mode fault detection is enabled.

1: Mode fault detection is disabled.

- **LLB: Local Loopback Enable**

0: Local loopback path disabled.

1: Local loopback path enabled

LLB controls the local loopback on the data serializer for testing in Master Mode only. (MISO is internally connected on MOSI.)

- **PCS: Peripheral Chip Select**

This field is only used if Fixed Peripheral Select is active (PS = 0).

If PCSDEC = 0:

| | |
|------------------|---------------------------------------|
| PCS = xxx0 | NPCS[3:0] = 1110 |
| PCS = xx01 | NPCS[3:0] = 1101 |
| PCS = x011 | NPCS[3:0] = 1011 |
| PCS = 0111 | NPCS[3:0] = 0111 |
| PCS = 1111 | forbidden (no peripheral is selected) |
| (x = don't care) | |

If PCSDEC = 1:

NPCS[3:0] output signals = PCS.

- **DLYBCS: Delay Between Chip Selects**

This field defines the delay from NPCS inactive to the activation of another NPCS. The DLYBCS time guarantees non-overlapping chip selects and solves bus contentions in case of peripherals having long data float times.

If DLYBCS is less than or equal to six, six MCK periods will be inserted by default.

Otherwise, the following equation determines the delay:

$$\text{Delay Between Chip Selects} = \frac{DLYBCS}{MCK}$$

29.7.3 SPI Receive Data Register

Name: SPI_RDR

Address: 0xFFFC8008 (0), 0xFFFC008 (1)

Access: Read-only

| | | | | | | | |
|----|----|----|----|-----|----|----|----|
| 31 | 30 | 29 | 28 | 27 | 26 | 25 | 24 |
| – | – | – | – | – | – | – | – |
| 23 | 22 | 21 | 20 | 19 | 18 | 17 | 16 |
| – | – | – | – | PCS | | | |
| 15 | 14 | 13 | 12 | 11 | 10 | 9 | 8 |
| RD | | | | | | | |
| 7 | 6 | 5 | 4 | 3 | 2 | 1 | 0 |
| RD | | | | | | | |

- **RD: Receive Data**

Data received by the SPI Interface is stored in this register right-justified. Unused bits read zero.

- **PCS: Peripheral Chip Select**

In Master Mode only, these bits indicate the value on the NPCS pins at the end of a transfer. Otherwise, these bits read zero.

29.7.4 SPI Transmit Data Register

Name: SPI_TDR

Address: 0xFFFC800C (0), 0xFFFC00C (1)

Access: Write-only

| | | | | | | | | |
|----|----|----|----|-----|----|----|----------|--|
| 31 | 30 | 29 | 28 | 27 | 26 | 25 | 24 | |
| – | – | – | – | – | – | – | LASTXFER | |
| 23 | 22 | 21 | 20 | 19 | 18 | 17 | 16 | |
| – | – | – | – | PCS | | | | |
| 15 | 14 | 13 | 12 | 11 | 10 | 9 | 8 | |
| TD | | | | | | | | |
| 7 | 6 | 5 | 4 | 3 | 2 | 1 | 0 | |
| TD | | | | | | | | |

- **TD: Transmit Data**

Data to be transmitted by the SPI Interface is stored in this register. Information to be transmitted must be written to the transmit data register in a right-justified format.

- **PCS: Peripheral Chip Select**

This field is only used if Variable Peripheral Select is active (PS = 1).

If PCSDEC = 0:

| | |
|------------------|---------------------------------------|
| PCS = xxx0 | NPCS[3:0] = 1110 |
| PCS = xx01 | NPCS[3:0] = 1101 |
| PCS = x011 | NPCS[3:0] = 1011 |
| PCS = 0111 | NPCS[3:0] = 0111 |
| PCS = 1111 | forbidden (no peripheral is selected) |
| (x = don't care) | |

If PCSDEC = 1:

NPCS[3:0] output signals = PCS

- **LASTXFER: Last Transfer**

0: No effect.

1: The current NPCS will be deasserted after the character written in TD has been transferred. When CSAAT is set, this allows to close the communication with the current serial peripheral by raising the corresponding NPCS line as soon as TD transfer has completed.

This field is only used if Variable Peripheral Select is active (PS = 1).

29.7.5 SPI Status Register

Name: SPI_SR

Address: 0xFFFC8010 (0), 0xFFFC010 (1)

Access: Read-only

| | | | | | | | |
|--------|--------|-------|-------|-------|------|---------|--------|
| 31 | 30 | 29 | 28 | 27 | 26 | 25 | 24 |
| – | – | – | – | – | – | – | – |
| 23 | 22 | 21 | 20 | 19 | 18 | 17 | 16 |
| – | – | – | – | – | – | – | SPIENS |
| 15 | 14 | 13 | 12 | 11 | 10 | 9 | 8 |
| – | – | – | – | – | – | TXEMPTY | NSSR |
| 7 | 6 | 5 | 4 | 3 | 2 | 1 | 0 |
| TXBUFE | RXBUFF | ENDTX | ENDRX | OVRES | MODF | TDRE | RDRF |

- **RDRF: Receive Data Register Full**

0: No data has been received since the last read of SPI_RDR

1: Data has been received and the received data has been transferred from the serializer to SPI_RDR since the last read of SPI_RDR.

- **TDRE: Transmit Data Register Empty**

0: Data has been written to SPI_TDR and not yet transferred to the serializer.

1: The last data written in the Transmit Data Register has been transferred to the serializer.

TDRE equals zero when the SPI is disabled or at reset. The SPI enable command sets this bit to one.

- **MODF: Mode Fault Error**

0: No Mode Fault has been detected since the last read of SPI_SR.

1: A Mode Fault occurred since the last read of the SPI_SR.

- **OVRES: Overrun Error Status**

0: No overrun has been detected since the last read of SPI_SR.

1: An overrun has occurred since the last read of SPI_SR.

An overrun occurs when SPI_RDR is loaded at least twice from the serializer since the last read of the SPI_RDR.

- **ENDRX: End of RX buffer**

0: The Receive Counter Register has not reached 0 since the last write in SPI_RCR⁽¹⁾ or SPI_RNCR⁽¹⁾.

1: The Receive Counter Register has reached 0 since the last write in SPI_RCR⁽¹⁾ or SPI_RNCR⁽¹⁾.

- **ENDTX: End of TX buffer**

0: The Transmit Counter Register has not reached 0 since the last write in SPI_TCR⁽¹⁾ or SPI_TNCR⁽¹⁾.

1: The Transmit Counter Register has reached 0 since the last write in SPI_TCR⁽¹⁾ or SPI_TNCR⁽¹⁾.

- **RXBUFF: RX Buffer Full**

0: SPI_RCR⁽¹⁾ or SPI_RNCR⁽¹⁾ has a value other than 0.

1: Both SPI_RCR⁽¹⁾ and SPI_RNCR⁽¹⁾ have a value of 0.

- **TXBUFE: TX Buffer Empty**

0: SPI_TCR⁽¹⁾ or SPI_TNCR⁽¹⁾ has a value other than 0.

1: Both SPI_TCR⁽¹⁾ and SPI_TNCR⁽¹⁾ have a value of 0.

- **NSSR: NSS Rising**

0: No rising edge detected on NSS pin since last read.

1: A rising edge occurred on NSS pin since last read.

- **TXEMPTY: Transmission Registers Empty**

0: As soon as data is written in SPI_TDR.

1: SPI_TDR and internal shifter are empty. If a transfer delay has been defined, TXEMPTY is set after the completion of such delay.

- **SPIENS: SPI Enable Status**

0: SPI is disabled.

1: SPI is enabled.

Note: 1. SPI_RCR, SPI_RNCR, SPI_TCR, SPI_TNCR are physically located in the PDC.

29.7.6 SPI Interrupt Enable Register

Name: SPI_IER

Address: 0xFFFC8014 (0), 0xFFCC014 (1)

Access: Write-only

| | | | | | | | |
|--------|--------|-------|-------|-------|------|---------|------|
| 31 | 30 | 29 | 28 | 27 | 26 | 25 | 24 |
| – | – | – | – | – | – | – | – |
| 23 | 22 | 21 | 20 | 19 | 18 | 17 | 16 |
| – | – | – | – | – | – | – | – |
| 15 | 14 | 13 | 12 | 11 | 10 | 9 | 8 |
| – | – | – | – | – | – | TXEMPTY | NSSR |
| 7 | 6 | 5 | 4 | 3 | 2 | 1 | 0 |
| TXBUFE | RXBUFF | ENDTX | ENDRX | OVRES | MODF | TDRE | RDRF |

0: No effect.

1: Enables the corresponding interrupt.

- **RDRF: Receive Data Register Full Interrupt Enable**
- **TDRE: SPI Transmit Data Register Empty Interrupt Enable**
- **MODF: Mode Fault Error Interrupt Enable**
- **OVRES: Overrun Error Interrupt Enable**
- **ENDRX: End of Receive Buffer Interrupt Enable**
- **ENDTX: End of Transmit Buffer Interrupt Enable**
- **RXBUFF: Receive Buffer Full Interrupt Enable**
- **TXBUFE: Transmit Buffer Empty Interrupt Enable**
- **NSSR: NSS Rising Interrupt Enable**
- **TXEMPTY: Transmission Registers Empty Enable**

29.7.7 SPI Interrupt Disable Register

Name: SPI_IDR

Address: 0xFFFFC8018 (0), 0xFFFFCC018 (1)

Access: Write-only

| | | | | | | | |
|--------|--------|-------|-------|-------|------|---------|------|
| 31 | 30 | 29 | 28 | 27 | 26 | 25 | 24 |
| – | – | – | – | – | – | – | – |
| 23 | 22 | 21 | 20 | 19 | 18 | 17 | 16 |
| – | – | – | – | – | – | – | – |
| 15 | 14 | 13 | 12 | 11 | 10 | 9 | 8 |
| – | – | – | – | – | – | TXEMPTY | NSSR |
| 7 | 6 | 5 | 4 | 3 | 2 | 1 | 0 |
| TXBUFE | RXBUFF | ENDTX | ENDRX | OVRES | MODF | TDRE | RDRF |

0: No effect.

1: Disables the corresponding interrupt.

- **RDRF: Receive Data Register Full Interrupt Disable**
- **TDRE: SPI Transmit Data Register Empty Interrupt Disable**
- **MODF: Mode Fault Error Interrupt Disable**
- **OVRES: Overrun Error Interrupt Disable**
- **ENDRX: End of Receive Buffer Interrupt Disable**
- **ENDTX: End of Transmit Buffer Interrupt Disable**
- **RXBUFF: Receive Buffer Full Interrupt Disable**
- **TXBUFE: Transmit Buffer Empty Interrupt Disable**
- **NSSR: NSS Rising Interrupt Disable**
- **TXEMPTY: Transmission Registers Empty Disable**

29.7.8 SPI Interrupt Mask Register

Name: SPI_IMR

Address: 0xFFFFC801C (0), 0xFFFFCC01C (1)

Access: Read-only

| | | | | | | | |
|--------|----------|-------|-------|-------|------|---------|------|
| 31 | 30 | 29 | 28 | 27 | 26 | 25 | 24 |
| – | – | – | – | – | – | – | – |
| 23 | 22 | 21 | 20 | 19 | 18 | 17 | 16 |
| – | – | – | – | – | – | – | – |
| 15 | 14 | 13 | 12 | 11 | 10 | 9 | 8 |
| – | – | – | – | – | – | TXEMPTY | NSSR |
| 7 | 6 | 5 | 4 | 3 | 2 | 1 | 0 |
| TXBUFE | RXBUFFER | ENDTX | ENDRX | OVRES | MODF | TDRE | RDRF |

0: The corresponding interrupt is not enabled.

1: The corresponding interrupt is enabled.

- **RDRF: Receive Data Register Full Interrupt Mask**
- **TDRE: SPI Transmit Data Register Empty Interrupt Mask**
- **MODF: Mode Fault Error Interrupt Mask**
- **OVRES: Overrun Error Interrupt Mask**
- **ENDRX: End of Receive Buffer Interrupt Mask**
- **ENDTX: End of Transmit Buffer Interrupt Mask**
- **RXBUFFER: Receive Buffer Full Interrupt Mask**
- **TXBUFE: Transmit Buffer Empty Interrupt Mask**
- **NSSR: NSS Rising Interrupt Mask**
- **TXEMPTY: Transmission Registers Empty Mask**

29.7.9 SPI Chip Select Register

Name: SPI_CSR0... SPI_CSR3

Address: 0xFFFFC8030 (0), 0xFFFFCC030 (1)

Access: Read/Write

| | | | | | | | |
|--------|----|----|----|-------|----|-------|------|
| 31 | 30 | 29 | 28 | 27 | 26 | 25 | 24 |
| DLYBCT | | | | | | | |
| 23 | 22 | 21 | 20 | 19 | 18 | 17 | 16 |
| DLYBS | | | | | | | |
| 15 | 14 | 13 | 12 | 11 | 10 | 9 | 8 |
| SCBR | | | | | | | |
| 7 | 6 | 5 | 4 | 3 | 2 | 1 | 0 |
| BITS | | | | CSAAT | – | NCPHA | CPOL |

Note: SPI_CSRx must be written even if the user wants to use the defaults. The BITS field will not be updated with the translated value unless the register is written.

• CPOL: Clock Polarity

0: The inactive state value of SPCK is logic level zero.

1: The inactive state value of SPCK is logic level one.

CPOL is used to determine the inactive state value of the serial clock (SPCK). It is used with NCPHA to produce the required clock/data relationship between master and slave devices.

• NCPHA: Clock Phase

0: Data is changed on the leading edge of SPCK and captured on the following edge of SPCK.

1: Data is captured on the leading edge of SPCK and changed on the following edge of SPCK.

NCPHA determines which edge of SPCK causes data to change and which edge causes data to be captured. NCPHA is used with CPOL to produce the required clock/data relationship between master and slave devices.

• CSAAT: Chip Select Active After Transfer

0: The Peripheral Chip Select Line rises as soon as the last transfer is achieved.

1: The Peripheral Chip Select does not rise after the last transfer is achieved. It remains active until a new transfer is requested on a different chip select.

- **BITS: Bits Per Transfer**

(See the note below the SPI_CSR bitmap.)

The BITS field determines the number of data bits transferred. Reserved values should not be used.

| Value | Bits Per Transfer |
|-------|-------------------|
| 0000 | 8 |
| 0001 | 9 |
| 0010 | 10 |
| 0011 | 11 |
| 0100 | 12 |
| 0101 | 13 |
| 0110 | 14 |
| 0111 | 15 |
| 1000 | 16 |
| 1001 | Reserved |
| 1010 | Reserved |
| 1011 | Reserved |
| 1100 | Reserved |
| 1101 | Reserved |
| 1110 | Reserved |
| 1111 | Reserved |

- **SCBR: Serial Clock Baud Rate**

In Master Mode, the SPI Interface uses a modulus counter to derive the SPCK baud rate from the Master Clock MCK. The baud rate is selected by writing a value from 1 to 255 in the SCBR field. The following equations determine the SPCK baud rate:

$$\text{SPCK Baudrate} = \frac{MCK}{SCBR}$$

Programming the SCBR field at 0 is forbidden. Triggering a transfer while SCBR is at 0 can lead to unpredictable results. At reset, SCBR is 0 and the user has to program it at a valid value before performing the first transfer.

- **DLYBS: Delay Before SPCK**

This field defines the delay from NPCS valid to the first valid SPCK transition.

When DLYBS equals zero, the NPCS valid to SPCK transition is 1/2 the SPCK clock period.

Otherwise, the following equations determine the delay:

$$\text{Delay Before SPCK} = \frac{DLYBS}{MCK}$$

- **DLYBCT: Delay Between Consecutive Transfers**

This field defines the delay between two consecutive transfers with the same peripheral without removing the chip select. The delay is always inserted after each transfer and before removing the chip select if needed.

When DLYBCT equals zero, no delay between consecutive transfers is inserted and the clock keeps its duty cycle over the character transfers.

Otherwise, the following equation determines the delay:

$$\text{Delay Between Consecutive Transfers} = \frac{32 \times DLYBCT}{MCK}$$

30. Two Wire Interface (TWI)

30.1 Overview

The Atmel Two-wire Interface (TWI) interconnects components on a unique two-wire bus, made up of one clock line and one data line with speeds of up to 400 Kbits per second, based on a byte-oriented transfer format. It can be used with any Atmel Two-wire Interface bus Serial EEPROM and I²C compatible device such as Real Time Clock (RTC), Dot Matrix/Graphic LCD Controllers and Temperature Sensor, to name but a few. The TWI is programmable as a master or a slave with sequential or single-byte access. Multiple master capability is supported. Arbitration of the bus is performed internally and puts the TWI in slave mode automatically if the bus arbitration is lost.

A configurable baud rate generator permits the output data rate to be adapted to a wide range of core clock frequencies. [Table 30-1](#) below lists the compatibility level of the Atmel Two-wire Interface in Master Mode and a full I²C compatible device.

Table 30-1. Atmel TWI compatibility with i2C Standard

| I2C Standard | Atmel TWI |
|---|---------------|
| Standard Mode Speed (100 KHz) | Supported |
| Fast Mode Speed (400 KHz) | Supported |
| 7 or 10 bits Slave Addressing | Supported |
| START BYTE ⁽¹⁾ | Not Supported |
| Repeated Start (Sr) Condition | Supported |
| ACK and NACK Management | Supported |
| Slope control and input filtering (Fast mode) | Not Supported |
| Clock stretching | Supported |

Note: 1. START + b000000001 + Ack + Sr

30.2 Embedded Characteristics

- Compatibility with standard two-wire serial memory
- One, two or three bytes for slave address
- Sequential read/write operations

30.3 List of Abbreviations

Table 30-2. Abbreviations

| Abbreviation | Description |
|--------------|-------------------------|
| TWI | Two-wire Interface |
| A | Acknowledge |
| NA | Non Acknowledge |
| P | Stop |
| S | Start |
| Sr | Repeated Start |
| SADR | Slave Address |
| ADR | Any address except SADR |
| R | Read |
| W | Write |

30.4 Block Diagram

Figure 30-1. Block Diagram

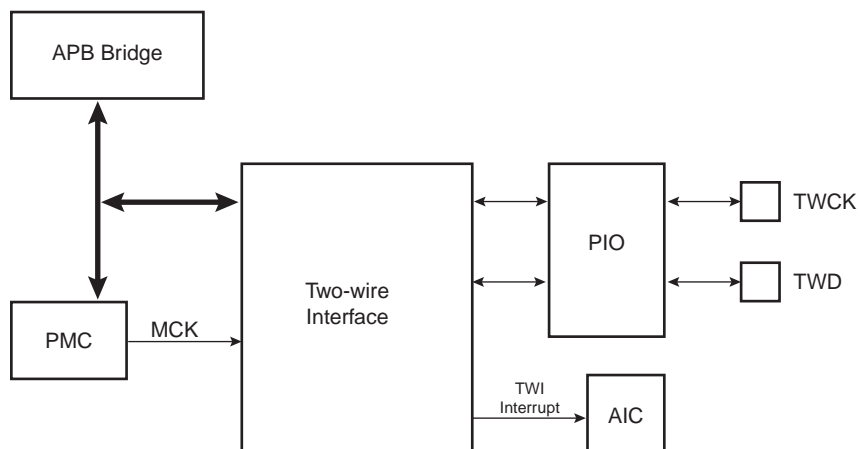

30.5 Application Block Diagram

Figure 30-2. Application Block Diagram

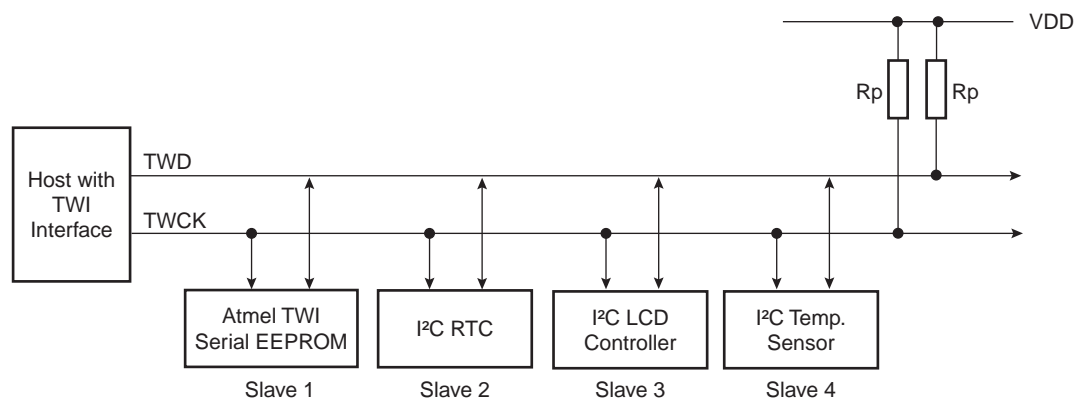

Rp: Pull up value as given by the I²C Standard

30.5.1 I/O Lines Description

Table 30-3. I/O Lines Description

| Pin Name | Pin Description | Type |
|----------|-----------------------|--------------|
| TWD | Two-wire Serial Data | Input/Output |
| TWCK | Two-wire Serial Clock | Input/Output |

30.6 Product Dependencies

30.6.1 I/O Lines

Both TWD and TWCK are bidirectional lines, connected to a positive supply voltage via a current source or pull-up resistor (see Figure 30-2). When the bus is free, both lines are high. The output stages of devices connected to the bus must have an open-drain or open-collector to perform the wired-AND function.

TWD and TWCK pins may be multiplexed with PIO lines. To enable the TWI, the programmer must perform the following step:

- Program the PIO controller to dedicate TWD and TWCK as peripheral lines.

The user must not program TWD and TWCK as open-drain. It is already done by the hardware.

30.6.2 Power Management

- Enable the peripheral clock.

The TWI interface may be clocked through the Power Management Controller (PMC), thus the programmer must first configure the PMC to enable the TWI clock.

30.6.3 Interrupt

The TWI interface has an interrupt line connected to the Advanced Interrupt Controller (AIC). In order to handle interrupts, the AIC must be programmed before configuring the TWI.

30.7 Functional Description

30.7.1 Transfer Format

The data put on the TWD line must be 8 bits long. Data is transferred MSB first; each byte must be followed by an acknowledgement. The number of bytes per transfer is unlimited (see [Figure 30-4](#)).

Each transfer begins with a START condition and terminates with a STOP condition (see [Figure 30-3](#)).

- A high-to-low transition on the TWD line while TWCK is high defines the START condition.
- A low-to-high transition on the TWD line while TWCK is high defines a STOP condition.

Figure 30-3. START and STOP Conditions

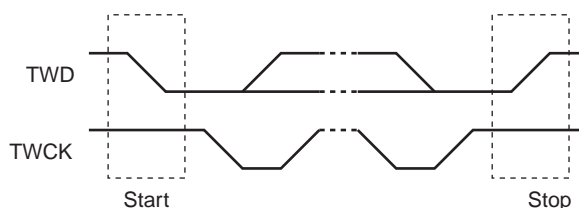
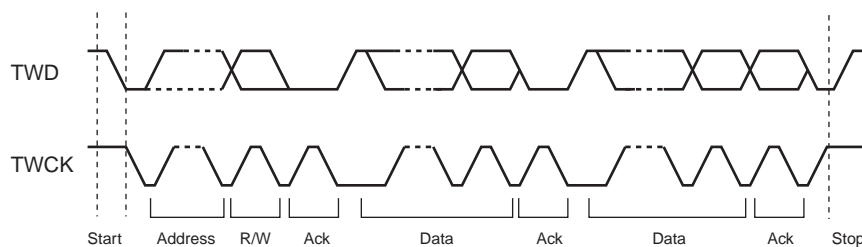

Figure 30-4. Transfer Format



30.7.2 Modes of Operation

The TWI has six modes of operations:

- Master transmitter mode
- Master receiver mode
- Multi-master transmitter mode
- Multi-master receiver mode
- Slave transmitter mode
- Slave receiver mode

These modes are described in the following chapters.

30.8 Master Mode

30.8.1 Definition

The Master is the device that starts a transfer, generates a clock and stops it.

30.8.2 Application Block Diagram

Figure 30-5. Master Mode Typical Application Block Diagram

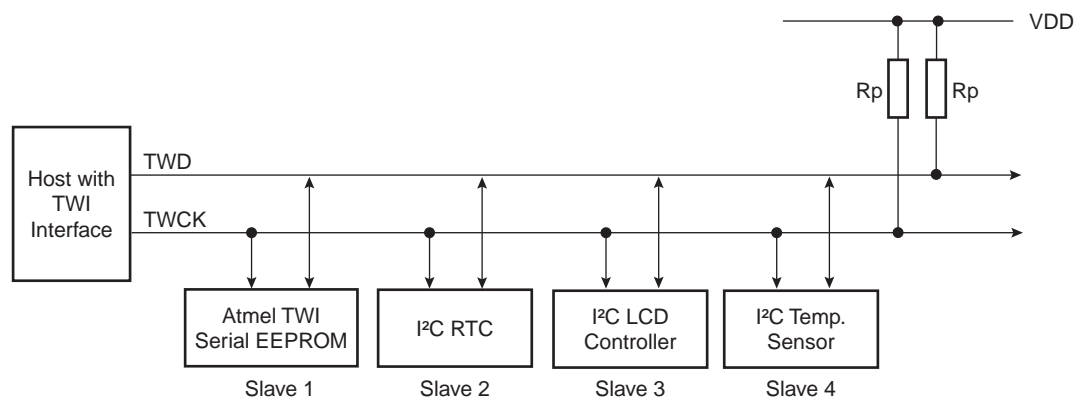

Rp: Pull up value as given by the I²C Standard

30.8.3 Programming Master Mode

The following registers have to be programmed before entering Master mode:

1. DADR (+ IADRSZ + IADR if a 10 bit device is addressed): The device address is used to access slave devices in read or write mode.
2. CKDIV + CHDIV + CLDIV: Clock Waveform.
3. SVDIS: Disable the slave mode.
4. MSEN: Enable the master mode.

30.8.4 Master Transmitter Mode

After the master initiates a Start condition when writing into the Transmit Holding Register, TWI_THR, it sends a 7-bit slave address, configured in the Master Mode register (DADR in TWI_MMR), to notify the slave device. The bit following the slave address indicates the transfer direction, 0 in this case (MREAD = 0 in TWI_MMR).

The TWI transfers require the slave to acknowledge each received byte. During the acknowledge clock pulse (9th pulse), the master releases the data line (HIGH), enabling the slave to pull it down in order to generate the acknowledge. The master polls the data line during this clock pulse and sets the Not Acknowledge bit (**NACK**) in the status register if the slave does not acknowledge the byte. As with the other status bits, an interrupt can be generated if enabled in the interrupt enable register (TWI_IER). If the slave acknowledges the byte, the data written in the TWI_THR, is then shifted in the internal shifter and transferred. When an acknowledge is detected, the TXRDY bit is set until a new write in the TWI_THR.

While no new data is written in the TWI_THR, the Serial Clock Line is tied low. When new data is written in the TWI_THR, the SCL is released and the data is sent. To generate a STOP event, the STOP command must be performed by writing in the STOP field of TWI_CR.

After a Master Write transfer, the Serial Clock line is stretched (tied low) while no new data is written in the TWI_THR or until a STOP command is performed.

See [Figure 30-6](#), [Figure 30-7](#), and [Figure 30-8](#).

Figure 30-6. Master Write with One Data Byte

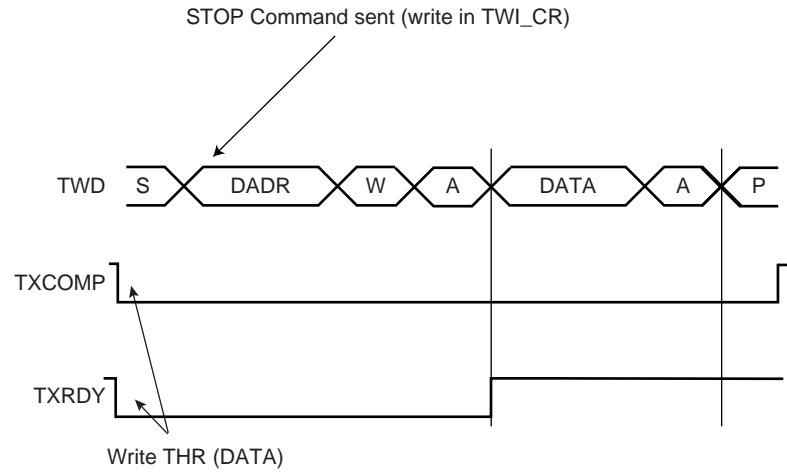

Figure 30-7. Master Write with Multiple Data Bytes

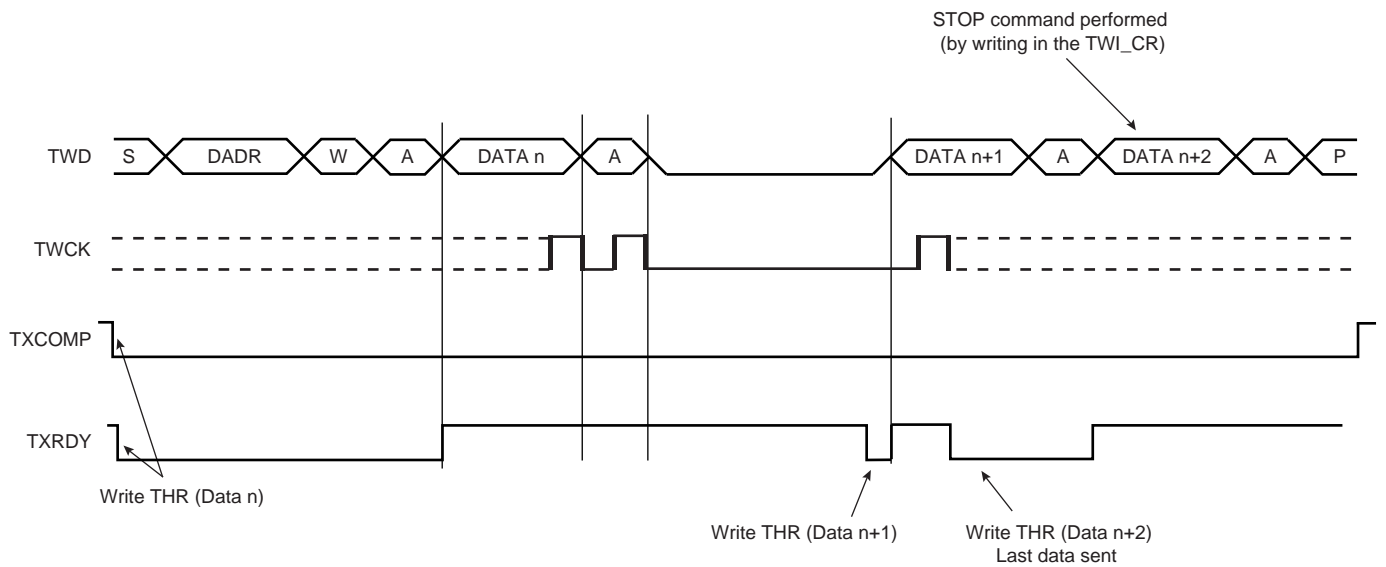
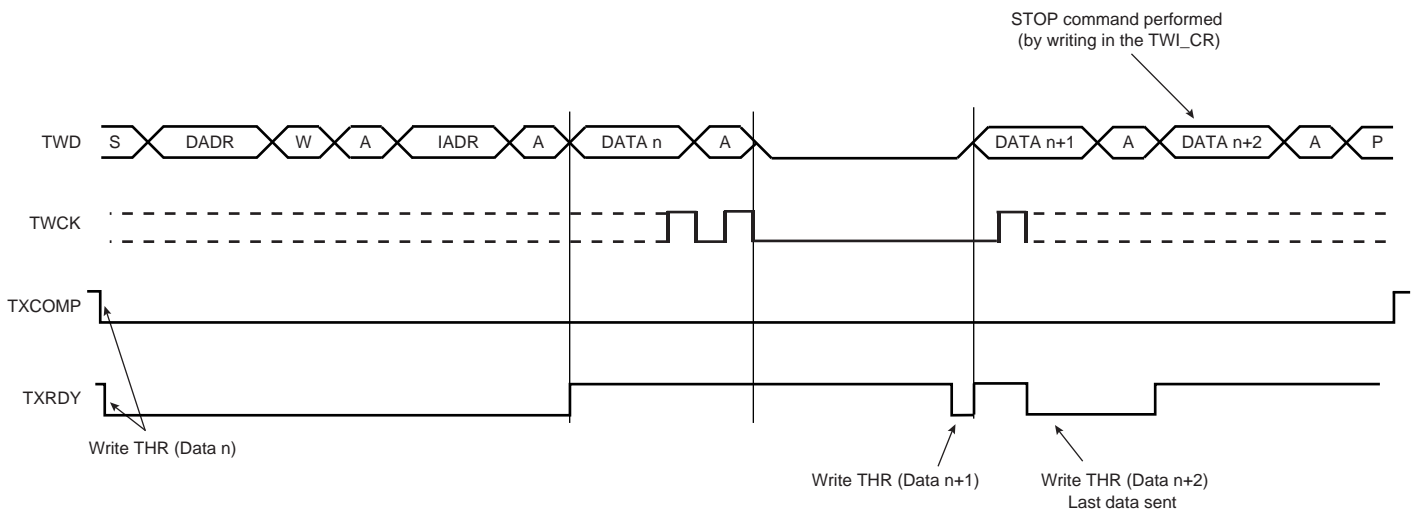

Figure 30-8. Master Write with One Byte Internal Address and Multiple Data Bytes



30.8.5 Master Receiver Mode

The read sequence begins by setting the START bit. After the start condition has been sent, the master sends a 7-bit slave address to notify the slave device. The bit following the slave address indicates the transfer direction, 1 in this case (MREAD = 1 in TWI_MMR). During the acknowledge clock pulse (9th pulse), the master releases the data line (HIGH), enabling the slave to pull it down in order to generate the acknowledge. The master polls the data line during this clock pulse and sets the **NACK** bit in the status register if the slave does not acknowledge the byte.

If an acknowledge is received, the master is then ready to receive data from the slave. After data has been received, the master sends an acknowledge condition to notify the slave that the data has been received except for the last data, after the stop condition. See Figure 30-9. When the RXRDY bit is set in the status register, a character has been received in the receive-holding register (TWI_RHR). The RXRDY bit is reset when reading the TWI_RHR.

When a single data byte read is performed, with or without internal address (**IADR**), the START and STOP bits must be set at the same time. See Figure 30-9. When a multiple data byte read is performed, with or without internal address (**IADR**), the STOP bit must be set after the next-to-last data received. See Figure 30-10. For Internal Address usage see Section 30.8.6.

Figure 30-9. Master Read with One Data Byte

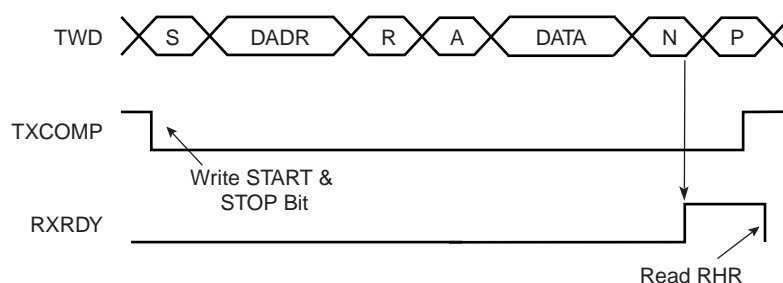
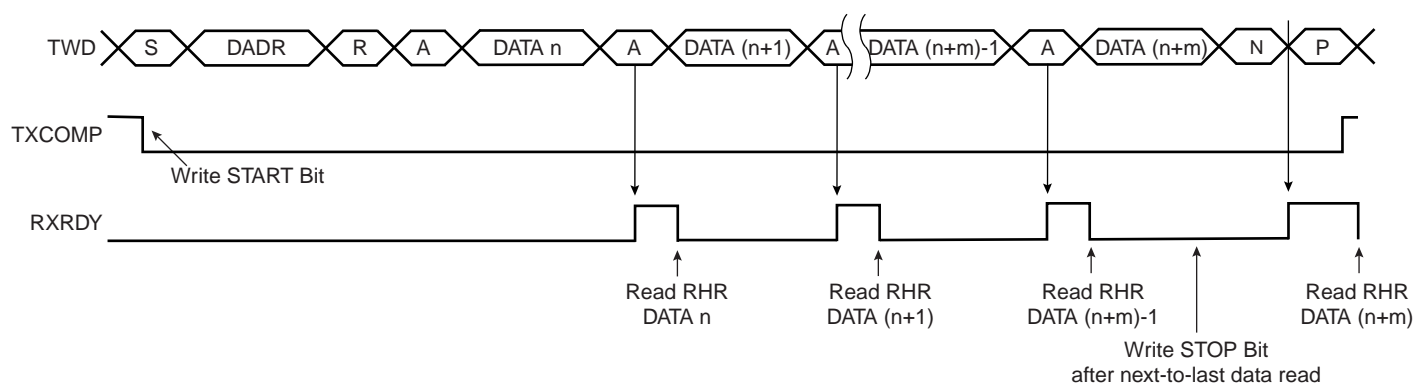

Figure 30-10. Master Read with Multiple Data Bytes



30.8.6 Internal Address

The TWI interface can perform various transfer formats: Transfers with 7-bit slave address devices and 10-bit slave address devices.

30.8.6.1 7-bit Slave Addressing

When Addressing 7-bit slave devices, the internal address bytes are used to perform random address (read or write) accesses to reach one or more data bytes, within a memory page location in a serial memory, for example. When performing read operations with an internal address, the TWI performs a write operation to set the internal address into the slave device, and then switch to Master Receiver mode. Note that the second start condition (after sending the IADR) is sometimes called “repeated start” (Sr) in I2C fully-compatible devices. See [Figure 30-12](#). See [Figure 30-11](#) and [Figure 30-13](#) for Master Write operation with internal address.

The three internal address bytes are configurable through the Master Mode register (TWI_MMR).

If the slave device supports only a 7-bit address, i.e. no internal address, **IADRSZ** must be set to 0.

In the figures below the following abbreviations are used:

- S Start
- Sr Repeated Start
- P Stop
- W Write
- R Read
- A Acknowledge
- N Not Acknowledge
- ~~DADR~~ Device Address
- ~~IADR~~ Internal Address

Figure 30-11. Master Write with One, Two or Three Bytes Internal Address and One Data Byte

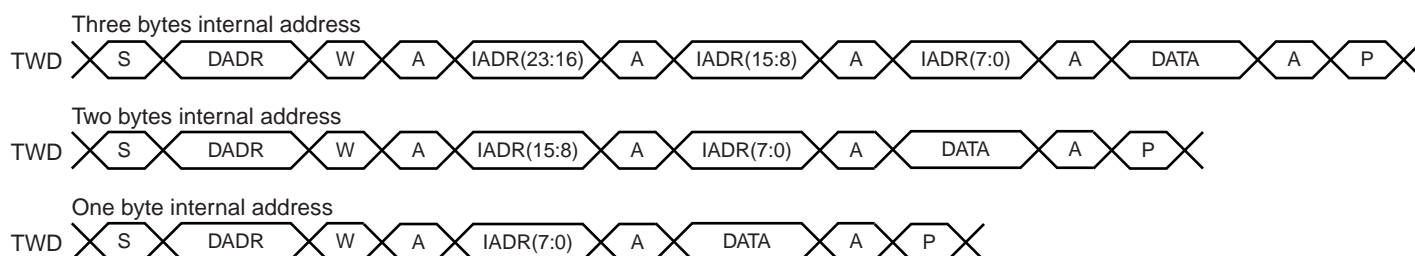
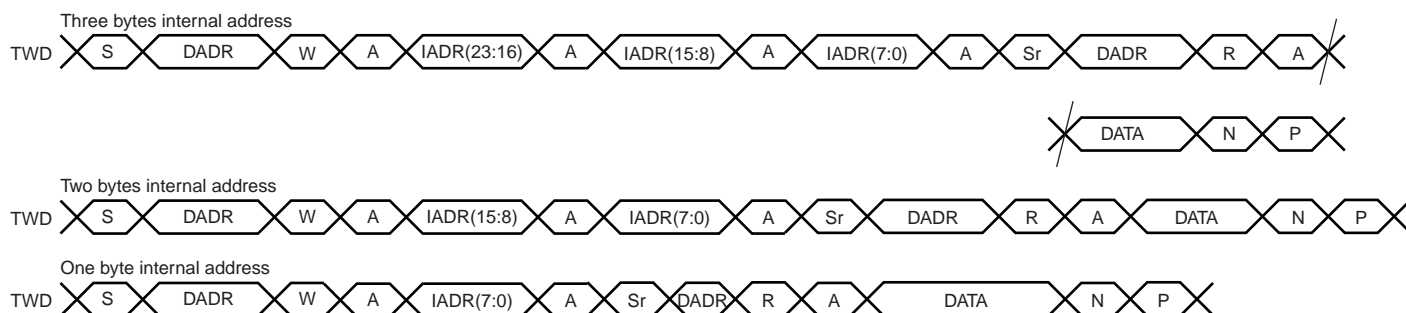

Figure 30-12. Master Read with One, Two or Three Bytes Internal Address and One Data Byte



30.8.6.2 10-bit Slave Addressing

For a slave address higher than 7 bits, the user must configure the address size (**IADRSZ**) and set the other slave address bits in the internal address register (TWI_IADR). The two remaining Internal address bytes, IADR[15:8] and IADR[23:16] can be used the same as in 7-bit Slave Addressing.

Example: Address a 10-bit device (10-bit device address is b1 b2 b3 b4 b5 b6 b7 b8 b9 b10)

1. Program IADRSZ = 1,
2. Program DADR with 1 1 1 1 0 b1 b2 (b1 is the MSB of the 10-bit address, b2, etc.)
3. Program TWI_IADR with b3 b4 b5 b6 b7 b8 b9 b10 (b10 is the LSB of the 10-bit address)

Figure 30-13 below shows a byte write to an Atmel AT24LC512 EEPROM. This demonstrates the use of internal addresses to access the device.

Figure 30-13. Internal Address Usage

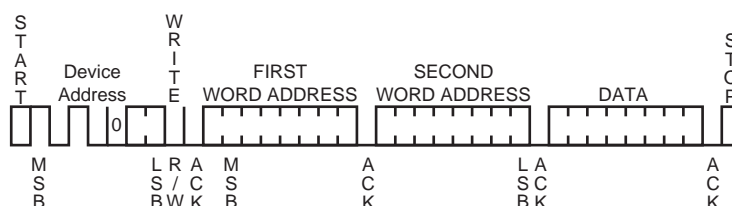

30.8.7 SMBUS Quick Command (Master Mode Only)

The TWI interface can perform a Quick Command:

1. Configure the master mode (DADR, CKDIV, etc.).
2. Write the MREAD bit in the TWI_MMR at the value of the one-bit command to be sent.
3. Start the transfer by setting the QUICK bit in the TWI_CR.

Figure 30-14. SMBUS Quick Command

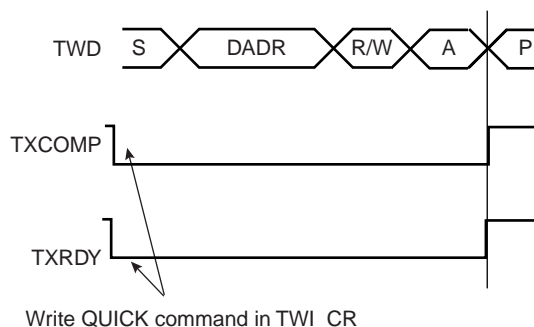

30.8.8 Read/Write Flowcharts

The flowcharts in the following figures provide examples of read and write operations. A polling or interrupt method can be used to check the status bits. The interrupt method requires that the interrupt enable register (TWI_IER) be configured first.

Figure 30-15. TWI Write Operation with Single Data Byte without Internal Address

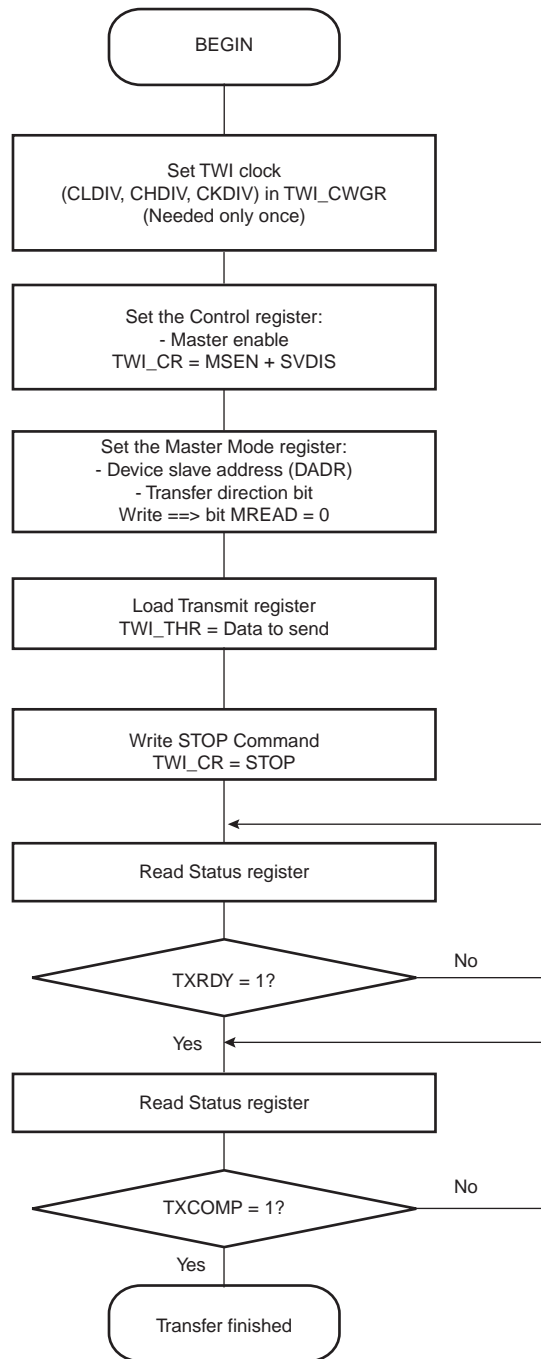

Figure 30-16. TWI Write Operation with Single Data Byte and Internal Address

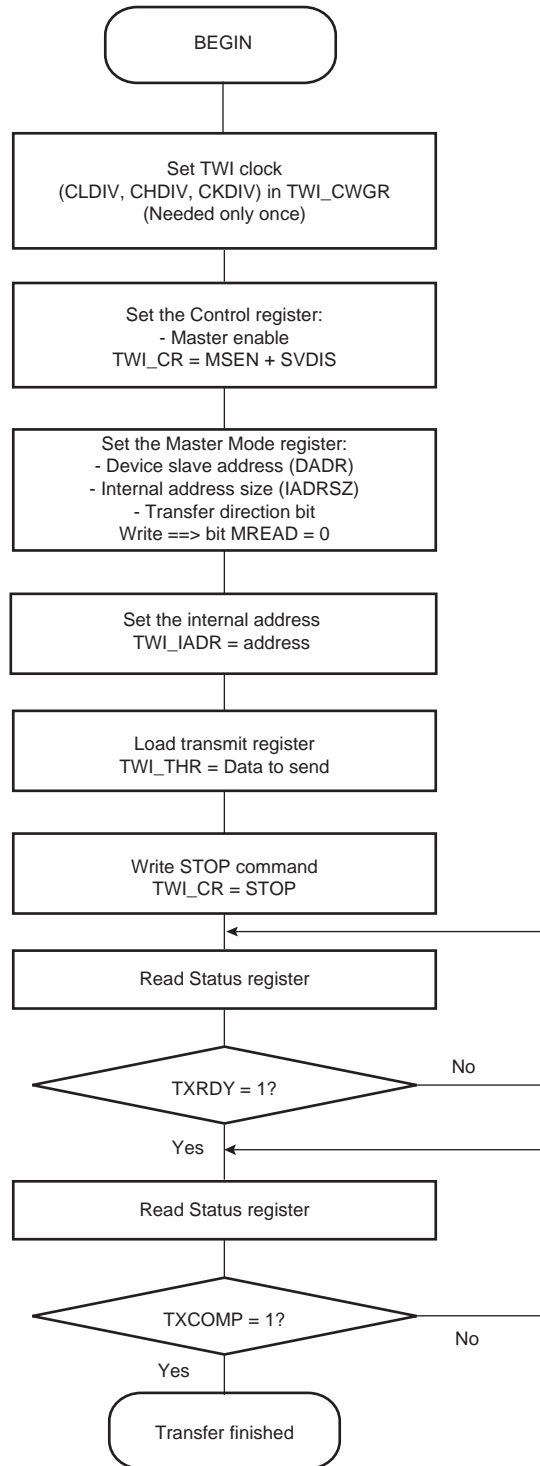

Figure 30-17. TWI Write Operation with Multiple Data Bytes with or without Internal Address

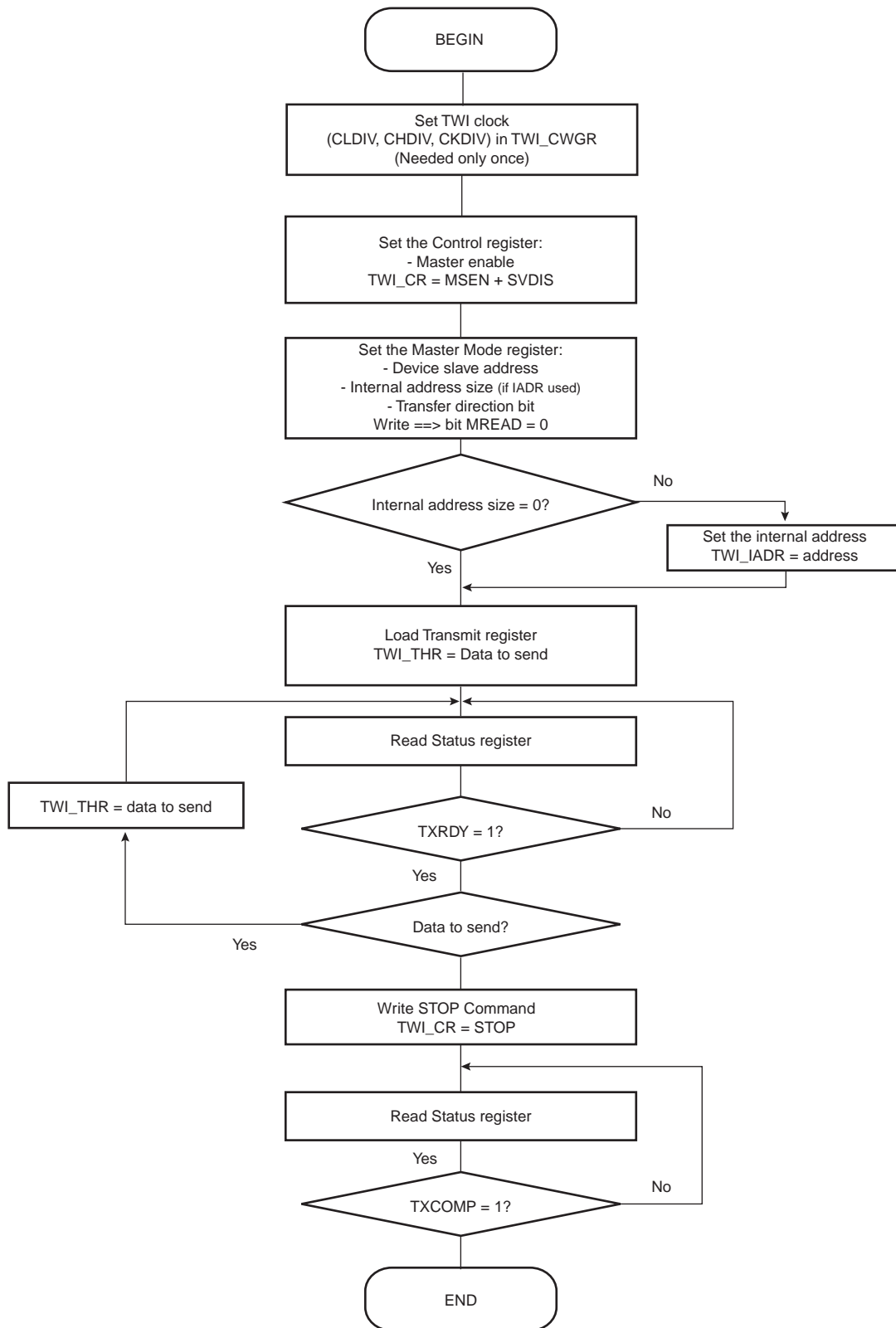

Figure 30-18. TWI Read Operation with Single Data Byte without Internal Address

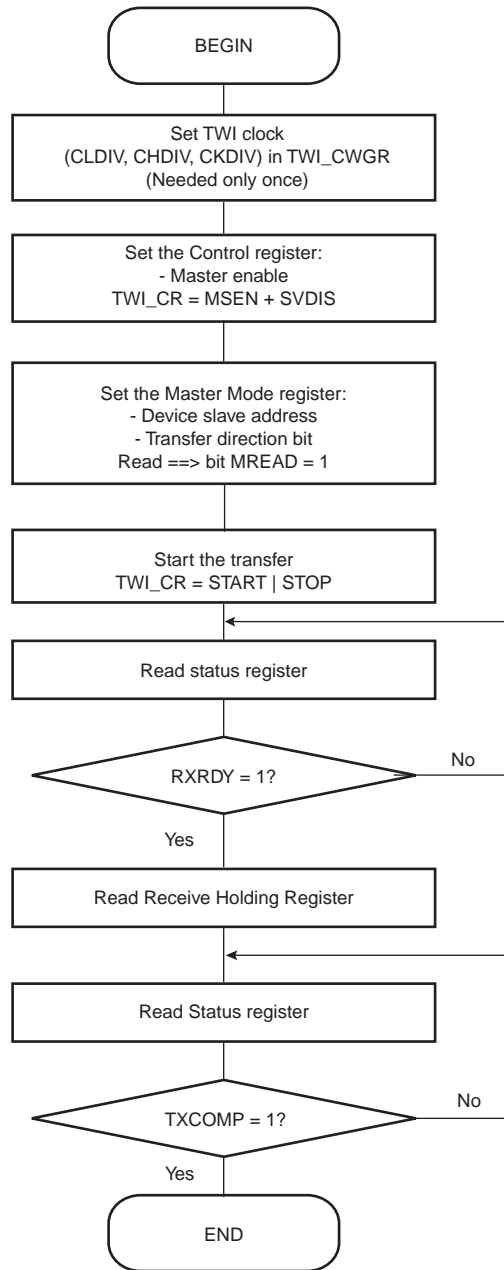

Figure 30-19. TWI Read Operation with Single Data Byte and Internal Address

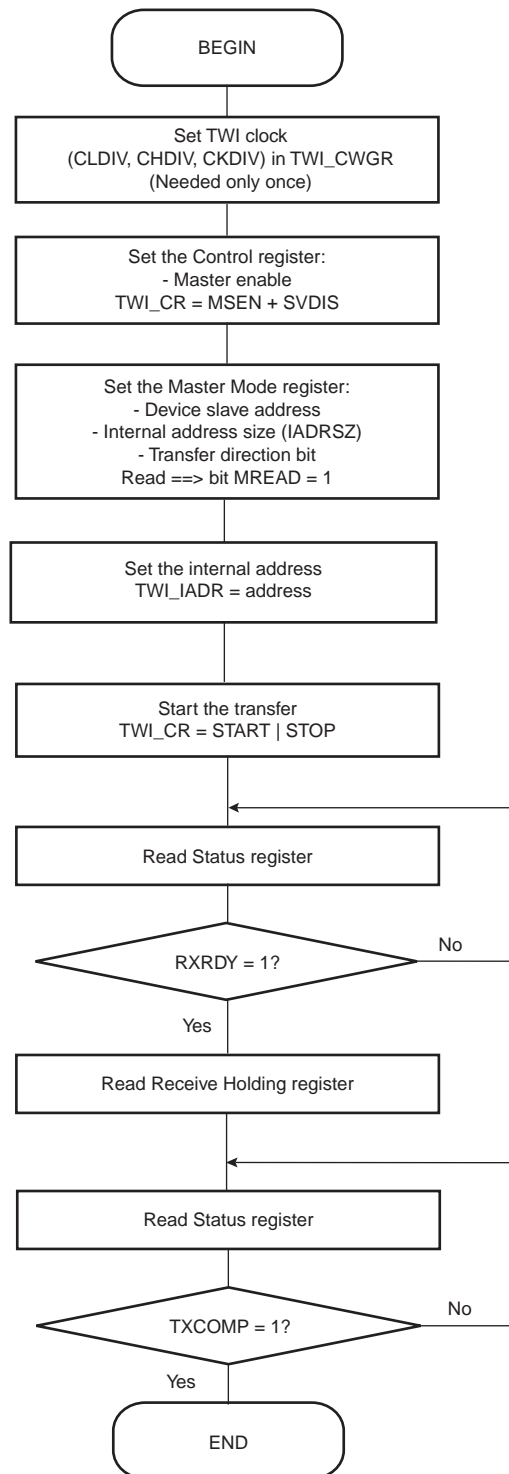
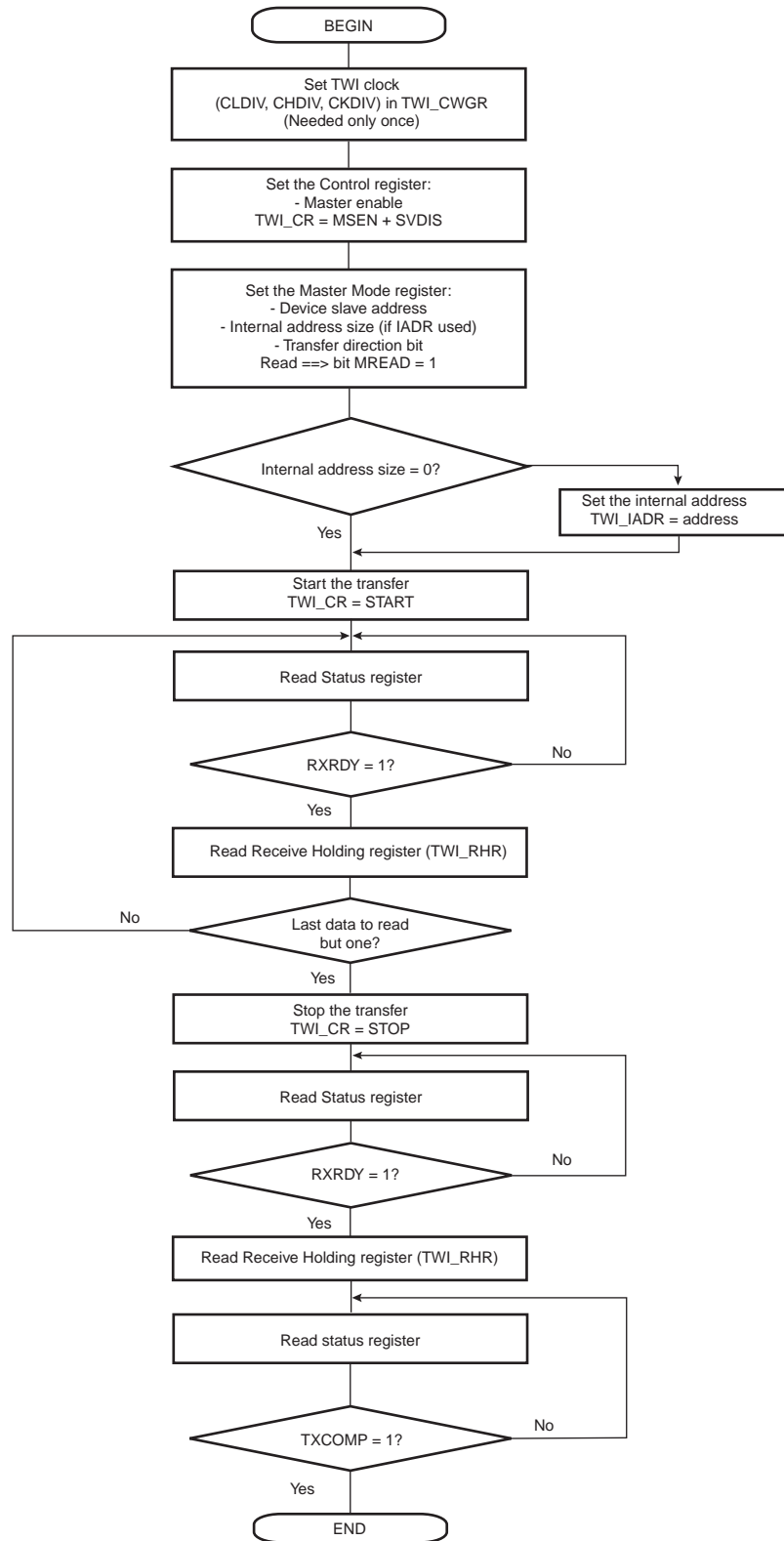

Figure 30-20. TWI Read Operation with Multiple Data Bytes with or without Internal Address



30.9 Multi-master Mode

30.9.1 Definition

More than one master may handle the bus at the same time without data corruption by using arbitration.

Arbitration starts as soon as two or more masters place information on the bus at the same time, and stops (arbitration is lost) for the master that intends to send a logical one while the other master sends a logical zero.

As soon as arbitration is lost by a master, it stops sending data and listens to the bus in order to detect a stop. When the stop is detected, the master who has lost arbitration may put its data on the bus by respecting arbitration.

Arbitration is illustrated in [Figure 30-22 on page 407](#).

30.9.2 Different Multi-master Modes

Two multi-master modes may be distinguished:

1. TWI is considered as a Master only and will never be addressed.
2. TWI may be either a Master or a Slave and may be addressed.

Note: In both Multi-master modes arbitration is supported.

30.9.2.1 TWI as Master Only

In this mode, TWI is considered as a Master only (MSEN is always at one) and must be driven like a Master with the ARBLST (ARBitration Lost) flag in addition.

If arbitration is lost (ARBLST = 1), the programmer must reinitiate the data transfer.

If the user starts a transfer (ex.: DADR + START + W + Write in THR) and if the bus is busy, the TWI automatically waits for a STOP condition on the bus to initiate the transfer (see [Figure 30-21 on page 407](#)).

Note: The state of the bus (busy or free) is not indicated in the user interface.

30.9.2.2 TWI as Master or Slave

The automatic reversal from Master to Slave is not supported in case of a lost arbitration.

Then, in the case where TWI may be either a Master or a Slave, the programmer must manage the pseudo Multi-master mode described in the steps below.

1. Program TWI in Slave mode (SADR + MSDIS + SVEN) and perform Slave Access (if TWI is addressed).
2. If TWI has to be set in Master mode, wait until TXCOMP flag is at 1.
3. Program Master mode (DADR + SVDIS + MSEN) and start the transfer (ex: START + Write in THR).
4. As soon as the Master mode is enabled, TWI scans the bus in order to detect if it is busy or free. When the bus is considered as free, TWI initiates the transfer.
5. As soon as the transfer is initiated and until a STOP condition is sent, the arbitration becomes relevant and the user must monitor the ARBLST flag.
6. If the arbitration is lost (ARBLST is set to 1), the user must program the TWI in Slave mode in the case where the Master that won the arbitration wanted to access the TWI.
7. If TWI has to be set in Slave mode, wait until TXCOMP flag is at 1 and then program the Slave mode.

Note: In the case where the arbitration is lost and TWI is addressed, TWI will not acknowledge even if it is programmed in Slave mode as soon as ARBLST is set to 1. Then, the Master must repeat SADR.

Figure 30-21. Programmer Sends Data While the Bus is Busy

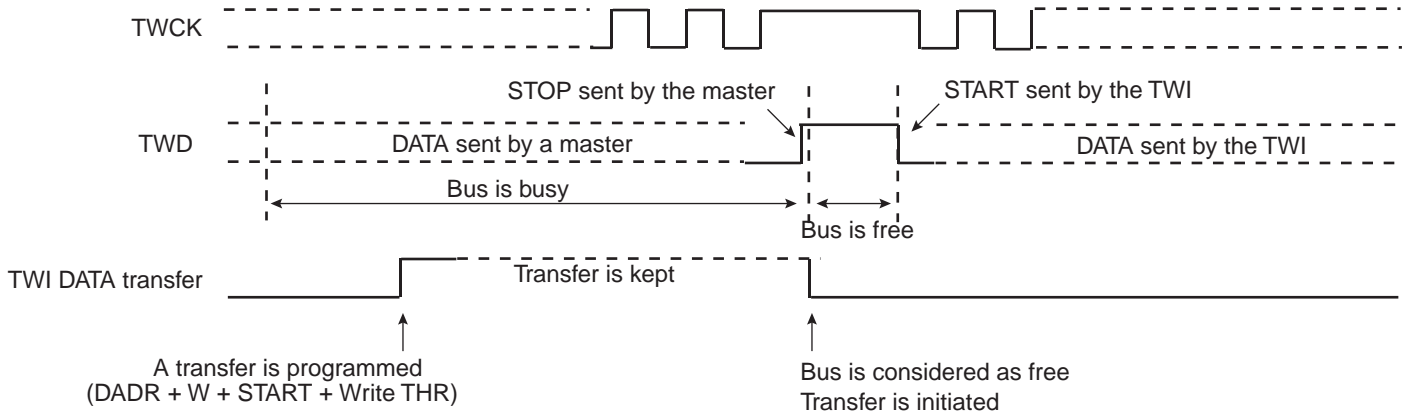
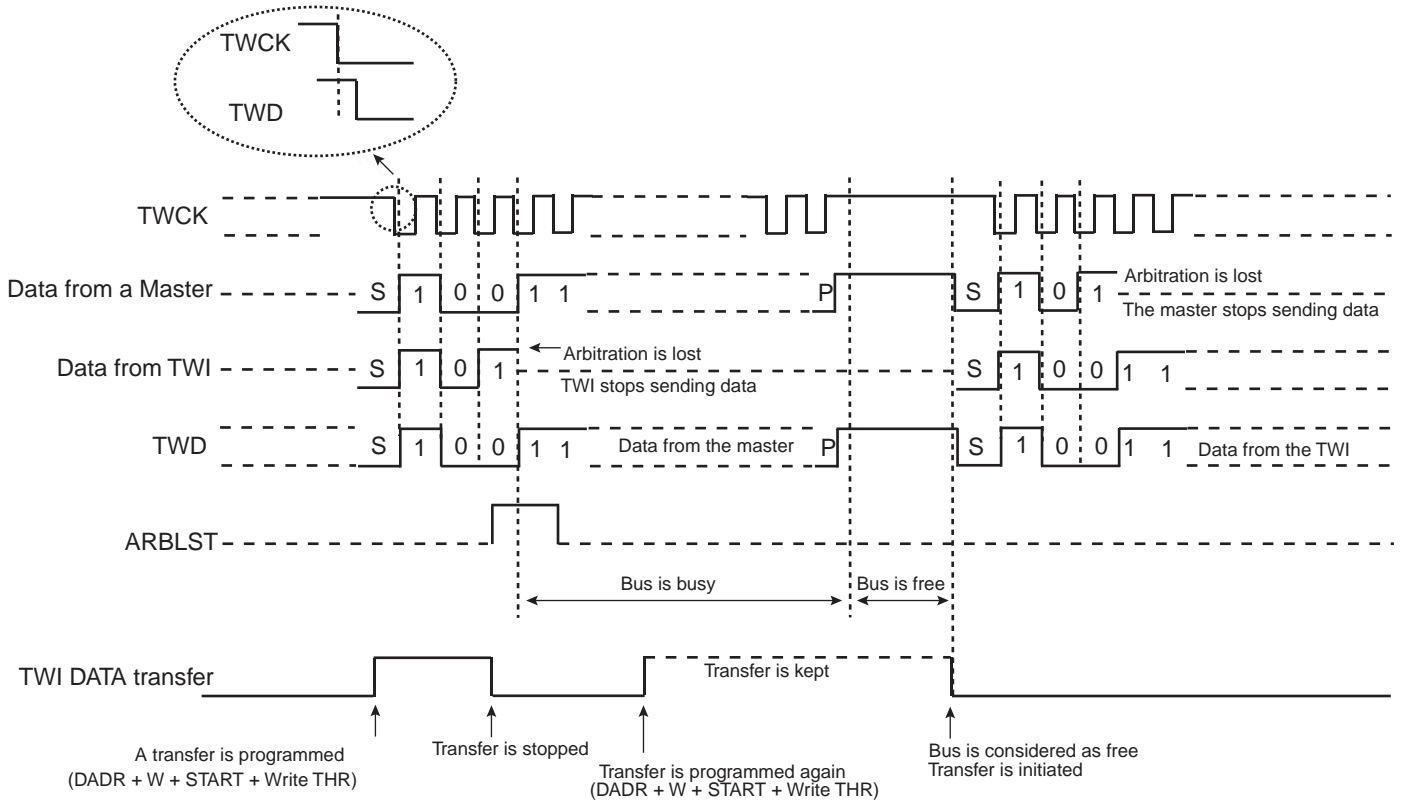
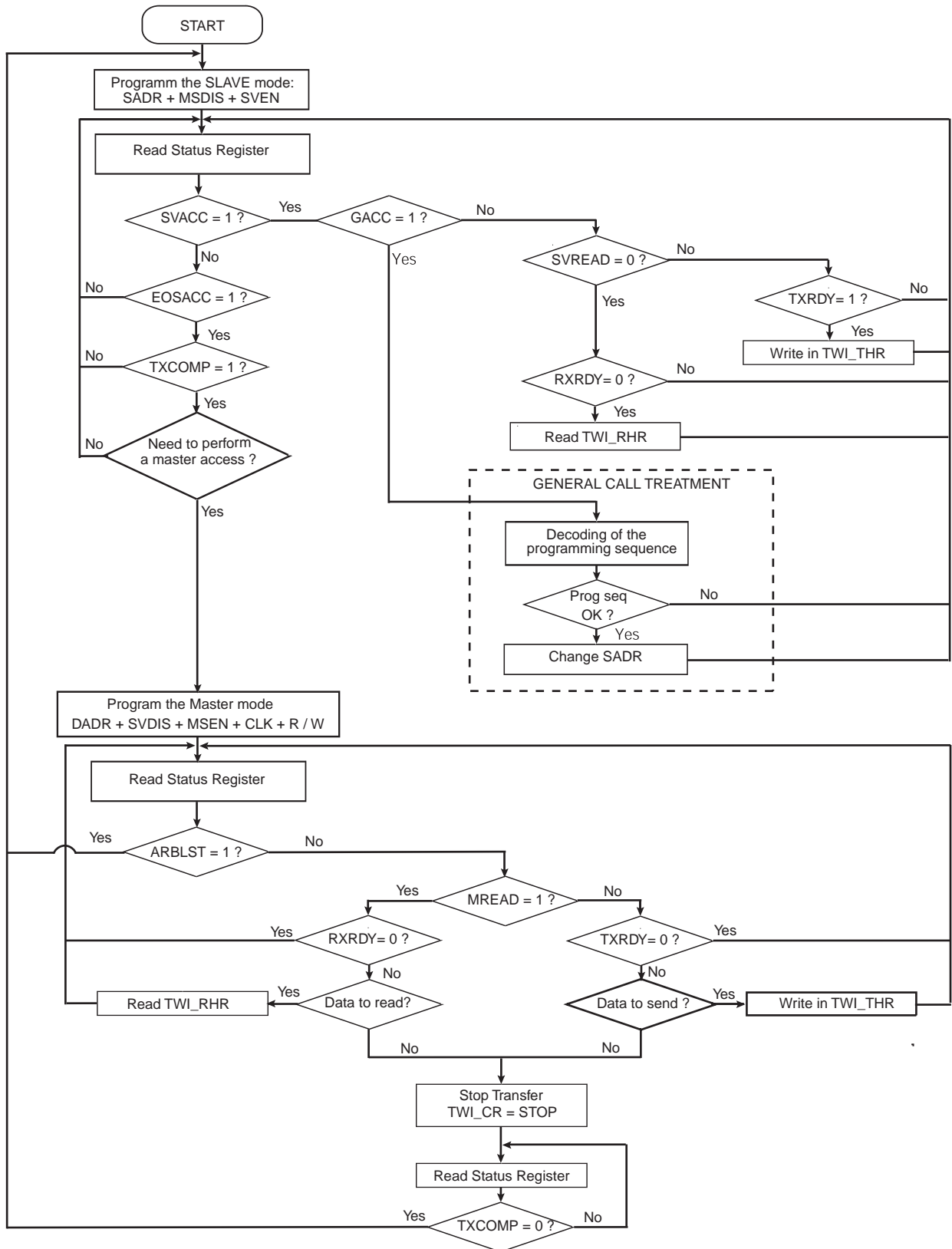

Figure 30-22. Arbitration Cases



The flowchart shown in [Figure 30-23 on page 408](#) gives an example of read and write operations in Multi-master mode.

Figure 30-23. Multi-master Flowchart



30.10 Slave Mode

30.10.1 Definition

The Slave Mode is defined as a mode where the device receives the clock and the address from another device called the master.

In this mode, the device never initiates and never completes the transmission (START, REPEATED_START and STOP conditions are always provided by the master).

30.10.2 Application Block Diagram

Figure 30-24. Slave Mode Typical Application Block Diagram

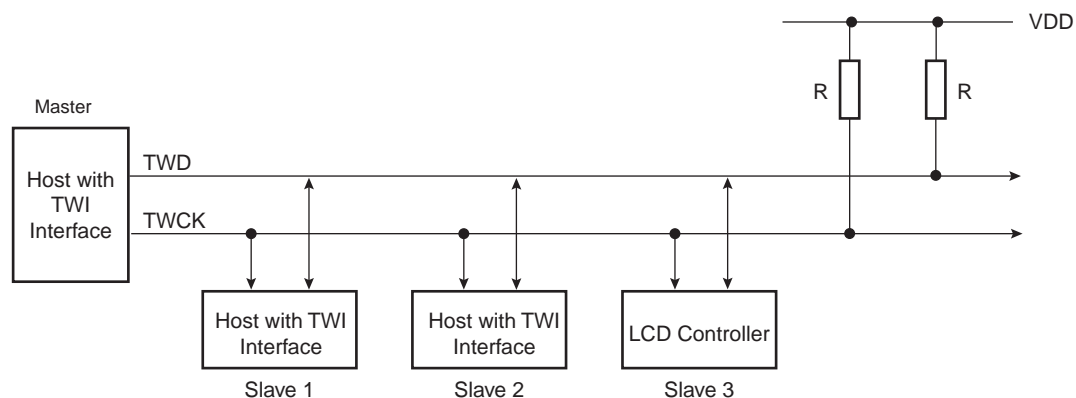

30.10.3 Programming Slave Mode

The following fields must be programmed before entering Slave mode:

1. SADR (TWI_SMR): The slave device address is used in order to be accessed by master devices in read or write mode.
2. MSDIS (TWI_CR): Disable the master mode.
3. SVEN (TWI_CR): Enable the slave mode.

As the device receives the clock, values written in TWI_CWGR are not taken into account.

30.10.4 Receiving Data

After a Start or Repeated Start condition is detected and if the address sent by the Master matches with the Slave address programmed in the SADR (Slave Address) field, SVACC (Slave ACCESS) flag is set and SVREAD (Slave READ) indicates the direction of the transfer.

SVACC remains high until a STOP condition or a repeated START is detected. When such a condition is detected, EOSACC (End Of Slave ACCESS) flag is set.

30.10.4.1 Read Sequence

In the case of a Read sequence (SVREAD is high), TWI transfers data written in the TWI_THR (TWI Transmit Holding Register) until a STOP condition or a REPEATED_START + an address different from SADR is detected. Note that at the end of the read sequence TXCOMP (Transmission Complete) flag is set and SVACC reset.

As soon as data is written in the TWI_THR, TXRDY (Transmit Holding Register Ready) flag is reset, and it is set when the shift register is empty and the sent data acknowledged or not. If the data is not acknowledged, the NACK flag is set.

Note that a STOP or a repeated START always follows a NACK.

See [Figure 30-25 on page 410](#).

30.10.4.2 Write Sequence

In the case of a Write sequence (SVREAD is low), the RXRDY (Receive Holding Register Ready) flag is set as soon as a character has been received in the TWI_RHR (TWI Receive Holding Register). RXRDY is reset when reading the TWI_RHR.

TWI continues receiving data until a STOP condition or a REPEATED_START + an address different from SADR is detected. Note that at the end of the write sequence TXCOMP flag is set and SVACC reset.

See [Figure 30-26 on page 411](#).

30.10.4.3 Clock Synchronization Sequence

In the case where TWI_THR or TWI_RHR is not written/read in time, TWI performs a clock synchronization.

Clock stretching information is given by the SCLWS (Clock Wait state) bit.

See [Figure 30-28 on page 412](#) and [Figure 30-29 on page 413](#).

30.10.4.4 General Call

In the case where a GENERAL CALL is performed, GACC (General Call ACCESS) flag is set.

After GACC is set, it is up to the programmer to interpret the meaning of the GENERAL CALL and to decode the new address programming sequence.

See [Figure 30-27 on page 411](#).

30.10.5 Data Transfer

30.10.5.1 Read Operation

The read mode is defined as a data requirement from the master.

After a START or a REPEATED START condition is detected, the decoding of the address starts. If the slave address (SADR) is decoded, SVACC is set and SVREAD indicates the direction of the transfer.

Until a STOP or REPEATED START condition is detected, TWI continues sending data loaded in the TWI_THR.

If a STOP condition or a REPEATED START + an address different from SADR is detected, SVACC is reset.

[Figure 30-25](#) describes the write operation.

Figure 30-25. Read Access Ordered by a MASTER

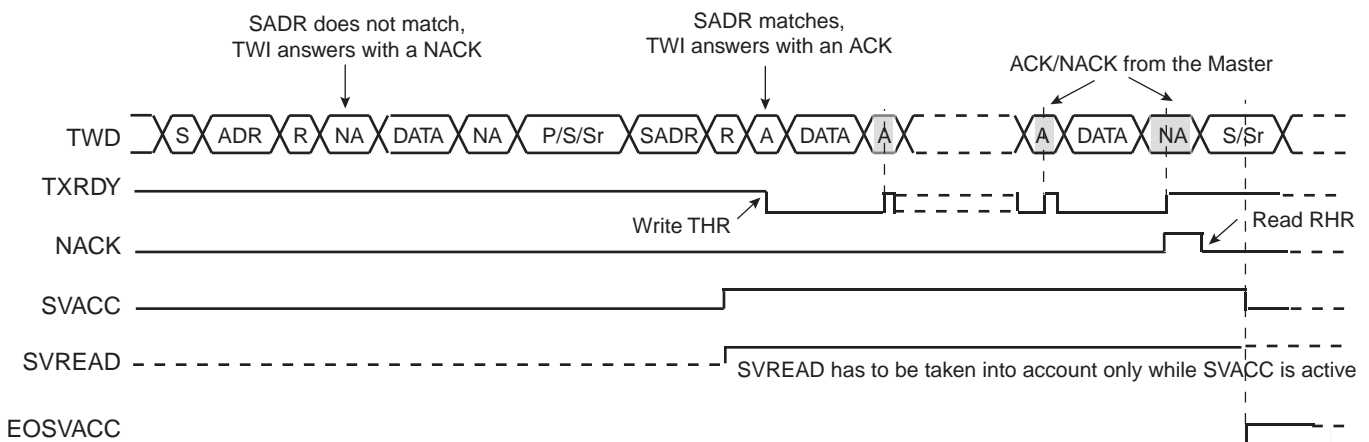

- Notes:
1. When SVACC is low, the state of SVREAD becomes irrelevant.
 2. TXRDY is reset when data has been transmitted from TWI_THR to the shift register and set when this data has been acknowledged or non acknowledged.

30.10.5.2 Write Operation

The write mode is defined as a data transmission from the master.

After a START or a REPEATED START, the decoding of the address starts. If the slave address is decoded, SVACC is set and SVREAD indicates the direction of the transfer (SVREAD is low in this case).

Until a STOP or REPEATED START condition is detected, TWI stores the received data in the TWI_RHR.

If a STOP condition or a REPEATED START + an address different from SADR is detected, SVACC is reset.

Figure 30-26 describes the Write operation.

Figure 30-26. Write Access Ordered by a Master

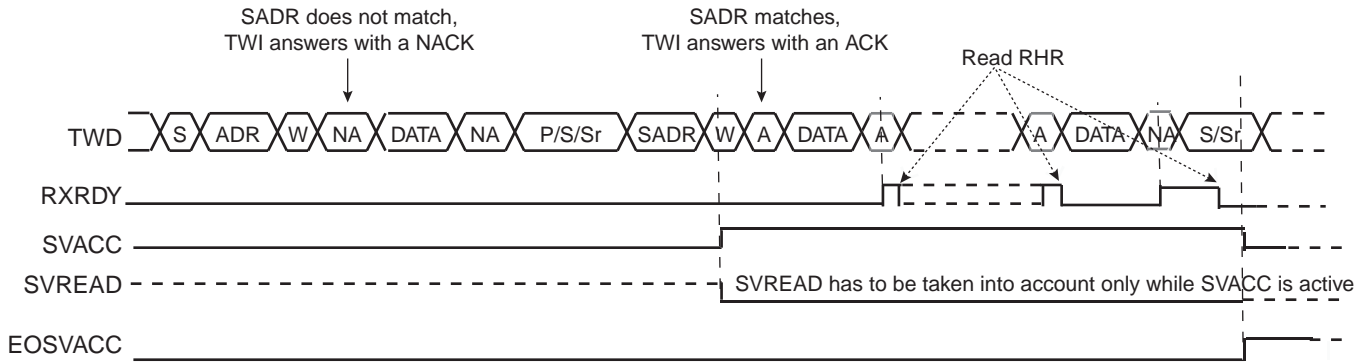

- Notes:
1. When SVACC is low, the state of SVREAD becomes irrelevant.
 2. RXRDY is set when data has been transmitted from the shift register to the TWI_RHR and reset when this data is read.

30.10.5.3 General Call

The general call is performed in order to change the address of the slave.

If a GENERAL CALL is detected, GACC is set.

After the detection of General Call, it is up to the programmer to decode the commands which come afterwards.

In case of a WRITE command, the programmer has to decode the programming sequence and program a new SADR if the programming sequence matches.

Figure 30-27 describes the General Call access.

Figure 30-27. Master Performs a General Call

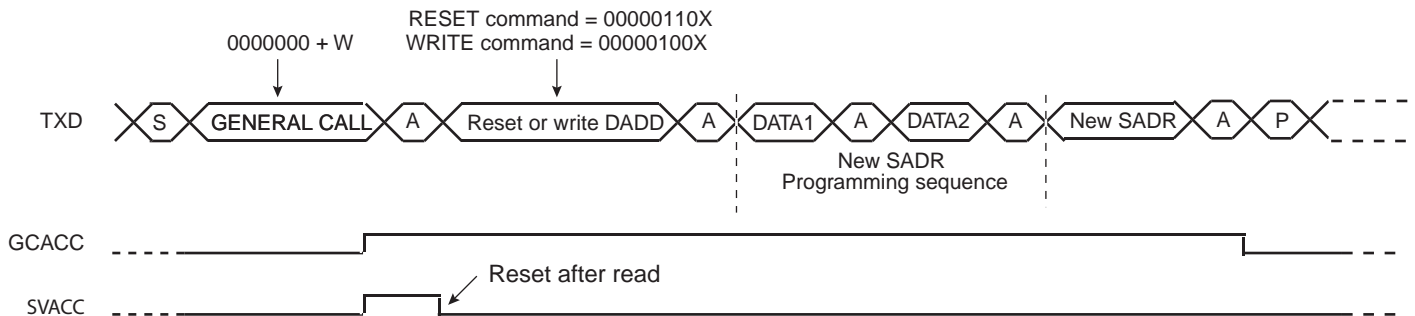

- Note: This method allows the user to create an own programming sequence by choosing the programming bytes and the number of them. The programming sequence has to be provided to the master.

30.10.5.4 Clock Synchronization

In both read and write modes, it may happen that TWI_THR/TWI_RHR buffer is not filled /emptied before the emission/reception of a new character. In this case, to avoid sending/receiving undesired data, a clock stretching mechanism is implemented.

Clock Synchronization in Read Mode

The clock is tied low if the shift register is empty and if a STOP or REPEATED START condition was not detected. It is tied low until the shift register is loaded.

Figure 30-28 describes the clock synchronization in Read mode.

Figure 30-28. Clock Synchronization in Read Mode

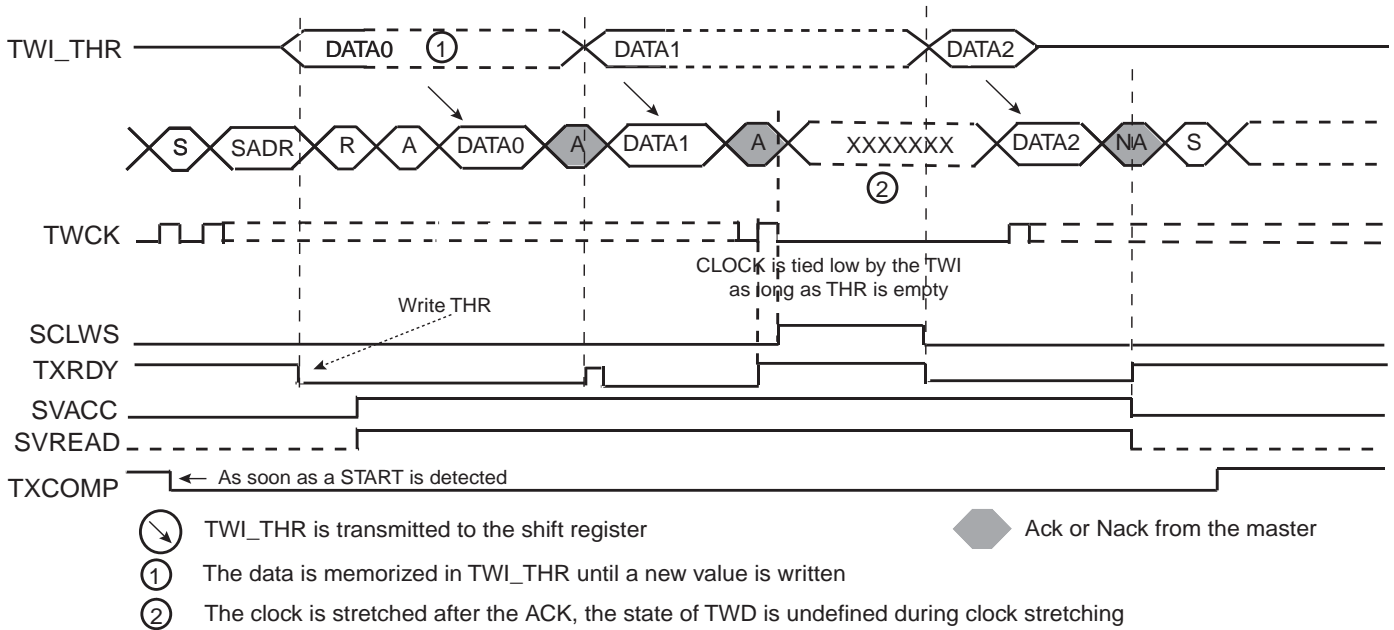

- Notes:
1. TXRDY is reset when data has been written in the TWI_THR to the shift register and set when this data has been acknowledged or non acknowledged.
 2. At the end of the read sequence, TXCOMP is set after a STOP or after a REPEATED_START + an address different from SADR.
 3. SCLWS is automatically set when the clock synchronization mechanism is started.

Clock Synchronization in Write Mode

The clock is tied low if the shift register and the TWI_RHR is full. If a STOP or REPEATED_START condition was not detected, it is tied low until TWI_RHR is read.

Figure 30-29 describes the clock synchronization in Read mode.

Figure 30-29. Clock Synchronization in Write Mode

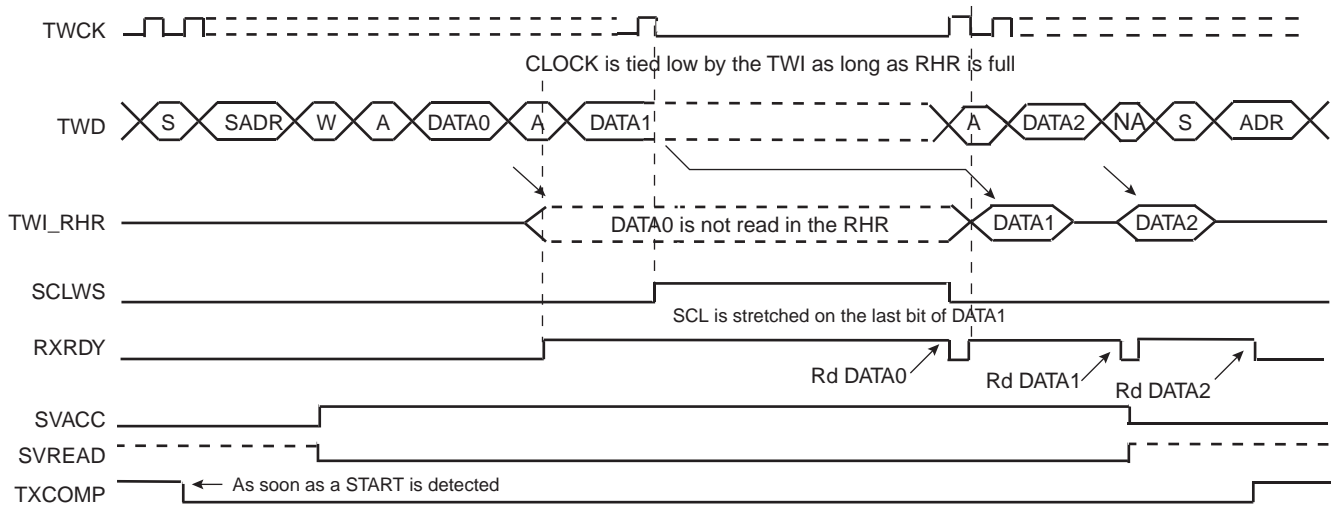

- Notes:
1. At the end of the read sequence, TXCOMP is set after a STOP or after a REPEATED_START + an address different from SADR.
 2. SCLWS is automatically set when the clock synchronization mechanism is started and automatically reset when the mechanism is finished.

30.10.5.5 Reversal after a Repeated Start

Reversal of Read to Write

The master initiates the communication by a read command and finishes it by a write command.

Figure 30-30 describes the repeated start + reversal from Read to Write mode.

Figure 30-30. Repeated Start + Reversal from Read to Write Mode

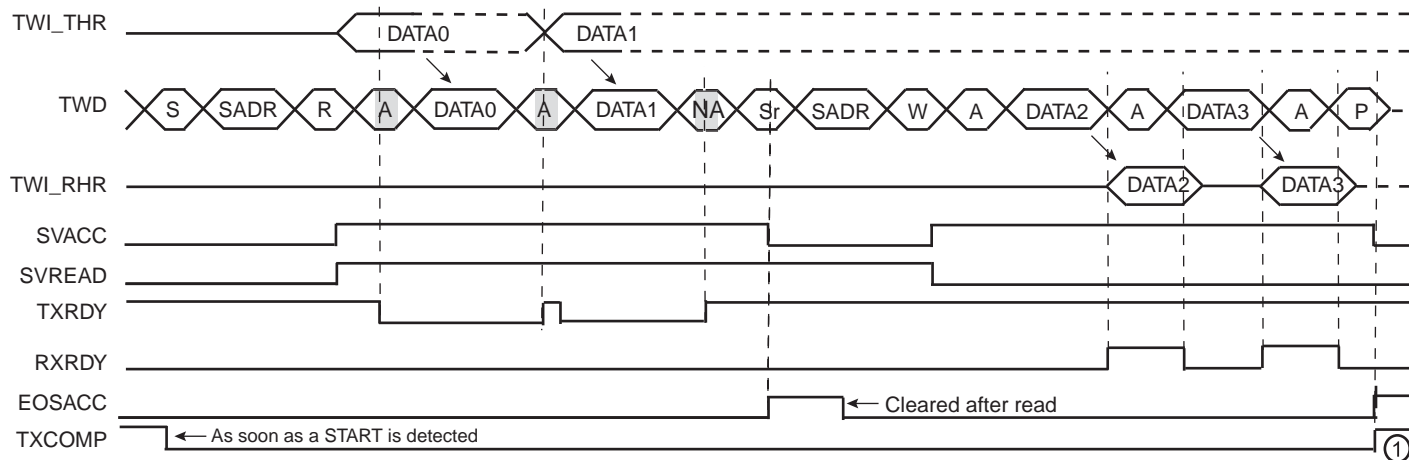

Note: 1. TXCOMP is only set at the end of the transmission because after the repeated start, SADR is detected again.

Reversal of Write to Read

The master initiates the communication by a write command and finishes it by a read command. Figure 30-31 describes the repeated start + reversal from Write to Read mode.

Figure 30-31. Repeated Start + Reversal from Write to Read Mode

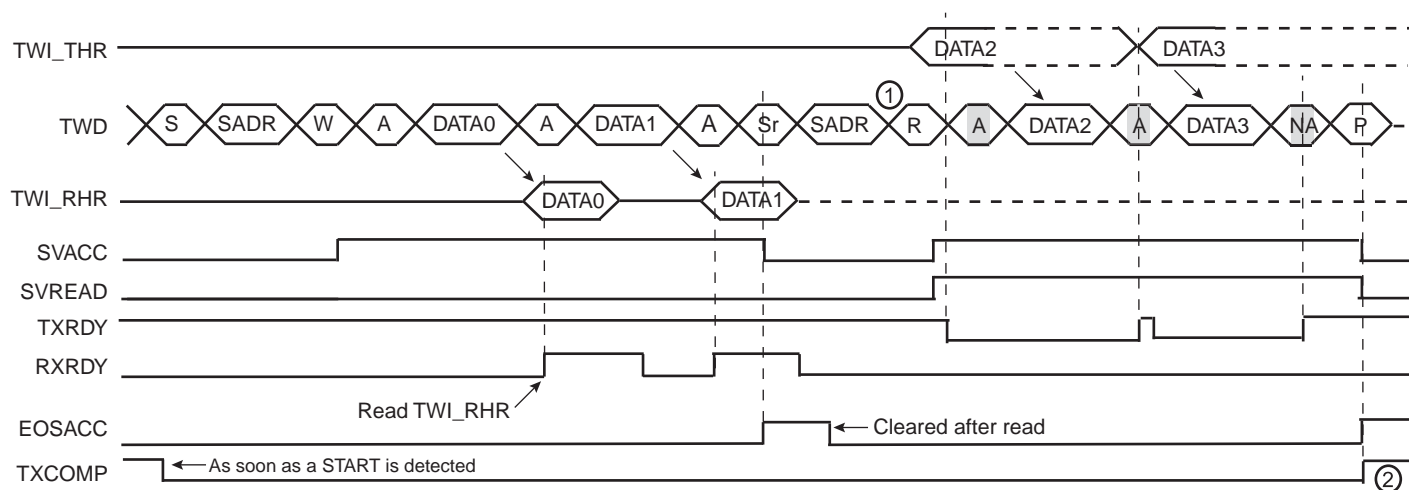

Notes: 1. In this case, if TWI_THR has not been written at the end of the read command, the clock is automatically stretched before the ACK.

2. TXCOMP is only set at the end of the transmission because after the repeated start, SADR is detected again.

30.10.6 Read Write Flowcharts

The flowchart shown in Figure 30-32 gives an example of read and write operations in Slave mode. A polling or interrupt method can be used to check the status bits. The interrupt method requires that the interrupt enable register (TWI_IER) be configured first.

Figure 30-32. Read Write Flowchart in Slave Mode

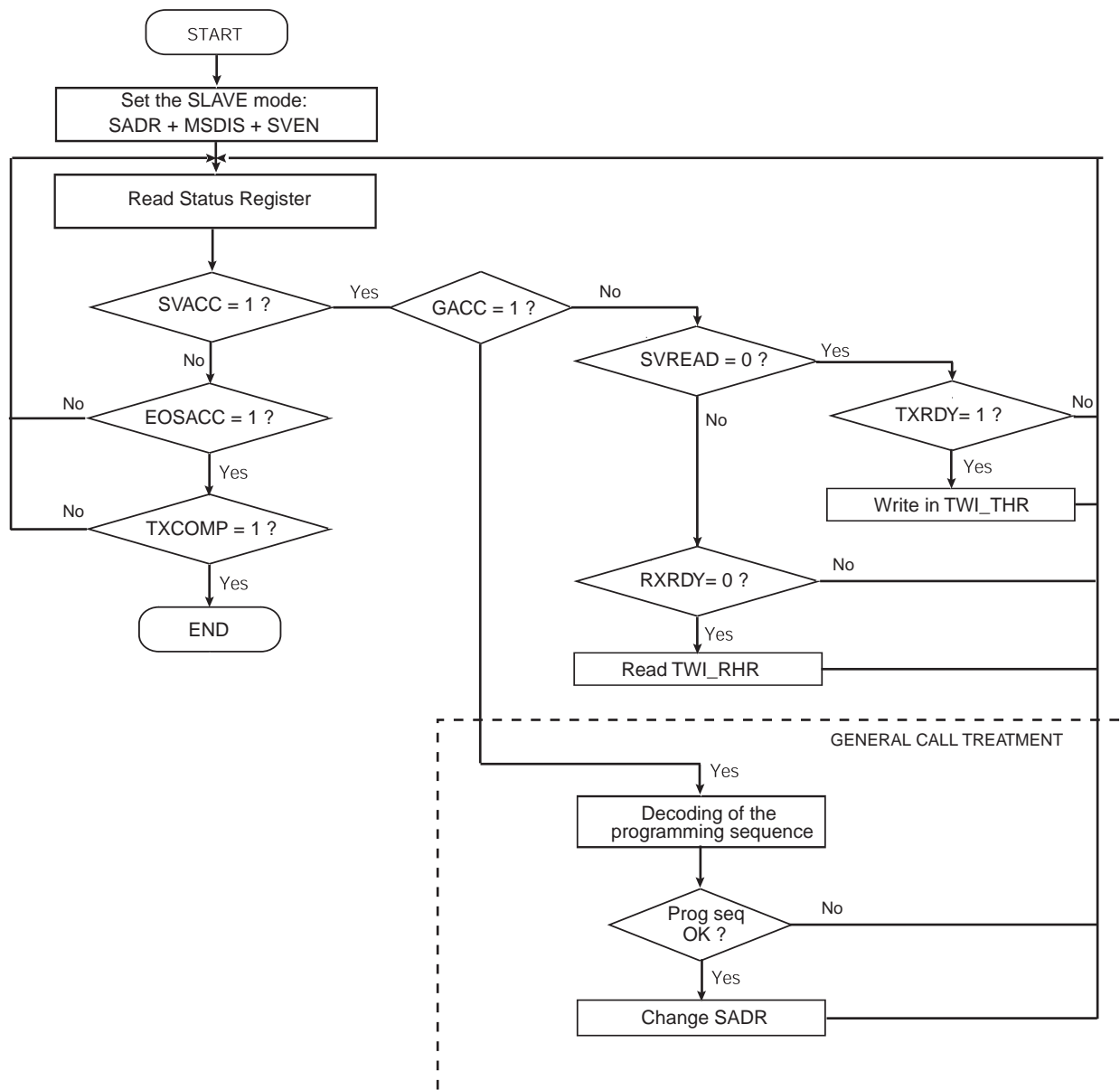

30.11 Two-wire Interface (TWI) User Interface

Table 30-4. Register Mapping

| Offset | Register | Name | Access | Reset |
|-----------|-----------------------------------|----------|------------|------------|
| 0x00 | Control Register | TWI_CR | Write-only | – |
| 0x04 | Master Mode Register | TWI_MMR | Read/Write | 0x00000000 |
| 0x08 | Slave Mode Register | TWI_SMR | Read/Write | 0x00000000 |
| 0x0C | Internal Address Register | TWI_IADR | Read/Write | 0x00000000 |
| 0x10 | Clock Waveform Generator Register | TWI_CWGR | Read/Write | 0x00000000 |
| 0x20 | Status Register | TWI_SR | Read-only | 0x0000F009 |
| 0x24 | Interrupt Enable Register | TWI_IER | Write-only | – |
| 0x28 | Interrupt Disable Register | TWI_IDR | Write-only | – |
| 0x2C | Interrupt Mask Register | TWI_IMR | Read-only | 0x00000000 |
| 0x30 | Receive Holding Register | TWI_RHR | Read-only | 0x00000000 |
| 0x34 | Transmit Holding Register | TWI_THR | Write-only | – |
| 0x38–0xFC | Reserved | – | – | – |

30.11.1 TWI Control Register

Name: TWI_CR

Address: 0xFFFFAC000

Access: Write-only

| | | | | | | | |
|-------|-------|-------|------|-------|------|------|-------|
| 31 | 30 | 29 | 28 | 27 | 26 | 25 | 24 |
| – | – | – | – | – | – | – | – |
| 23 | 22 | 21 | 20 | 19 | 18 | 17 | 16 |
| – | – | – | – | – | – | – | – |
| 15 | 14 | 13 | 12 | 11 | 10 | 9 | 8 |
| – | – | – | – | – | – | – | – |
| 7 | 6 | 5 | 4 | 3 | 2 | 1 | 0 |
| SWRST | QUICK | SVDIS | SVEN | MSDIS | MSEN | STOP | START |

- **START: Send a START Condition**

0: No effect.

1: A frame beginning with a START bit is transmitted according to the features defined in the mode register.

This action is necessary when the TWI peripheral wants to read data from a slave. When configured in Master Mode with a write operation, a frame is sent as soon as the user writes a character in the Transmit Holding Register (TWI_THR).

- **STOP: Send a STOP Condition**

0: No effect.

1: STOP Condition is sent just after completing the current byte transmission in master read mode.

- In single data byte master read, the START and STOP must both be set.
- In multiple data bytes master read, the STOP must be set after the last data received but one.
- In master read mode, if a NACK bit is received, the STOP is automatically performed.
- In master data write operation, a STOP condition will be sent after the transmission of the current data is finished.

- **MSEN: TWI Master Mode Enabled**

0: No effect.

1: If MSDIS = 0, the master mode is enabled.

Note: Switching from Slave to Master mode is only permitted when TXCOMP = 1.

- **MSDIS: TWI Master Mode Disabled**

0: No effect.

1: The master mode is disabled, all pending data is transmitted. The shifter and holding characters (if it contains data) are transmitted in case of write operation. In read operation, the character being transferred must be completely received before disabling.

- **SVEN: TWI Slave Mode Enabled**

0: No effect.

1: If SVDIS = 0, the slave mode is enabled.

Note: Switching from Master to Slave mode is only permitted when TXCOMP = 1.

- **SVDIS: TWI Slave Mode Disabled**

0: No effect.

1: The slave mode is disabled. The shifter and holding characters (if it contains data) are transmitted in case of read operation. In write operation, the character being transferred must be completely received before disabling.

- **QUICK: SMBUS Quick Command**

0: No effect.

1: If Master mode is enabled, a SMBUS Quick Command is sent.

- **SWRST: Software Reset**

0: No effect.

1: Equivalent to a system reset.

30.11.2 TWI Master Mode Register

Name: TWI_MMR
Address: 0xFFFFAC004
Access: Read/Write

| | | | | | | | |
|----|------|----|-------|----|----|--------|----|
| 31 | 30 | 29 | 28 | 27 | 26 | 25 | 24 |
| – | – | – | – | – | – | – | – |
| 23 | 22 | 21 | 20 | 19 | 18 | 17 | 16 |
| – | DADR | | | | | | |
| 15 | 14 | 13 | 12 | 11 | 10 | 9 | 8 |
| – | – | – | MREAD | – | – | IADRSZ | |
| 7 | 6 | 5 | 4 | 3 | 2 | 1 | 0 |
| – | – | – | – | – | – | – | – |

- **IADRSZ: Internal Device Address Size**

| Value | | Description |
|-------|---|------------------------------------|
| 0 | 0 | No internal device address |
| 0 | 1 | One-byte internal device address |
| 1 | 0 | Two-byte internal device address |
| 1 | 1 | Three-byte internal device address |

- **MREAD: Master Read Direction**

0: Master write direction.
1: Master read direction.

- **DADR: Device Address**

The device address is used to access slave devices in read or write mode. Those bits are only used in Master mode.

30.11.3 TWI Slave Mode Register

Name: TWI_SMR

Address: 0xFFFFAC008

Access: Read/Write

| | | | | | | | |
|----|------|----|----|----|----|----|----|
| 31 | 30 | 29 | 28 | 27 | 26 | 25 | 24 |
| – | – | – | – | – | – | – | – |
| 23 | 22 | 21 | 20 | 19 | 18 | 17 | 16 |
| – | SADR | | | | | | |
| 15 | 14 | 13 | 12 | 11 | 10 | 9 | 8 |
| – | – | – | – | – | – | – | – |
| 7 | 6 | 5 | 4 | 3 | 2 | 1 | 0 |
| – | – | – | – | – | – | – | – |

- **SADR: Slave Address**

The slave device address is used in Slave mode in order to be accessed by master devices in read or write mode.

SADR must be programmed before enabling the Slave mode or after a general call. Writes at other times have no effect.

30.11.4 TWI Internal Address Register

Name: TWI_IADR

Address: 0xFFFFAC00C

Access: Read/Write

| | | | | | | | |
|------|----|----|----|----|----|----|----|
| 31 | 30 | 29 | 28 | 27 | 26 | 25 | 24 |
| – | – | – | – | – | – | – | – |
| 23 | 22 | 21 | 20 | 19 | 18 | 17 | 16 |
| IADR | | | | | | | |
| 15 | 14 | 13 | 12 | 11 | 10 | 9 | 8 |
| IADR | | | | | | | |
| 7 | 6 | 5 | 4 | 3 | 2 | 1 | 0 |
| IADR | | | | | | | |

- **IADR: Internal Address**

0, 1, 2 or 3 bytes depending on IADRSZ.

30.11.5 TWI Clock Waveform Generator Register

Name: TWI_CWGR
 Address: 0xFFFFAC010
 Access: Read/Write

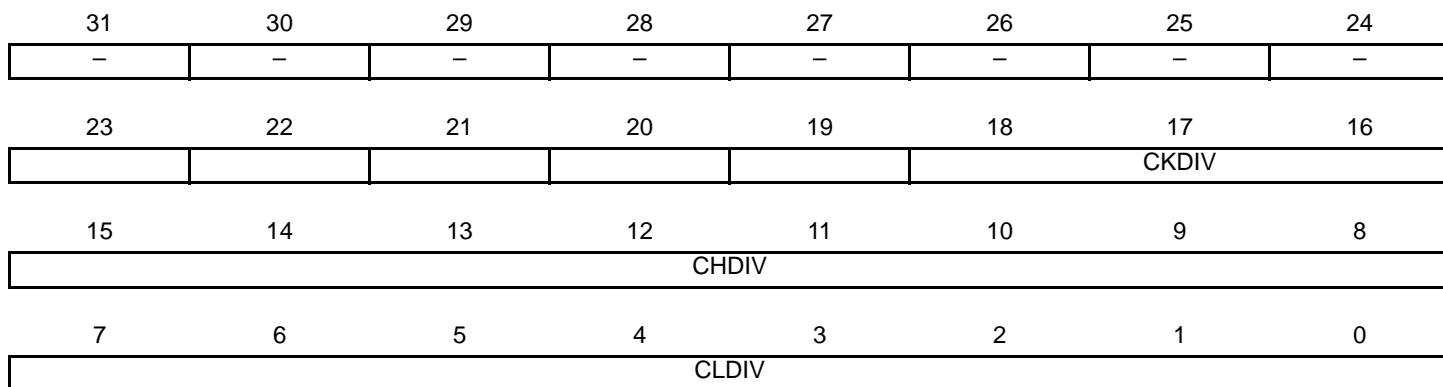

TWI_CWGR is only used in Master mode.

- **CLDIV: Clock Low Divider**

The SCL low period is defined as follows:

$$T_{low} = ((CLDIV \times 2^{CKDIV}) + 4) \times T_{MCK}$$

- **CHDIV: Clock High Divider**

The SCL high period is defined as follows:

$$T_{high} = ((CHDIV \times 2^{CKDIV}) + 4) \times T_{MCK}$$

- **CKDIV: Clock Divider**

The CKDIV is used to increase both SCL high and low periods.

30.11.6 TWI Status Register

Name: TWI_SR

Address: 0xFFFFAC020

Access: Read-only

| | | | | | | | |
|----|------|------|-------|--------|-------|--------|--------|
| 31 | 30 | 29 | 28 | 27 | 26 | 25 | 24 |
| – | – | – | – | – | – | – | – |
| 23 | 22 | 21 | 20 | 19 | 18 | 17 | 16 |
| – | – | – | – | – | – | – | – |
| 15 | 14 | 13 | 12 | 11 | 10 | 9 | 8 |
| | | | | EOSACC | SCLWS | ARBLST | NACK |
| 7 | 6 | 5 | 4 | 3 | 2 | 1 | 0 |
| – | OVRE | GACC | SVACC | SVREAD | TXRDY | RXRDY | TXCOMP |

- **TXCOMP: Transmission Completed (automatically set / reset)**

TXCOMP used in Master mode:

0: During the length of the current frame.

1: When both holding and shifter registers are empty and STOP condition has been sent.

TXCOMP behavior in Master mode can be seen in [Figure 30-8 on page 396](#) and in [Figure 30-10 on page 397](#).

TXCOMP used in Slave mode:

0: As soon as a Start is detected.

1: After a Stop or a Repeated Start + an address different from SADR is detected.

TXCOMP behavior in Slave mode can be seen in [Figure 30-28 on page 412](#), [Figure 30-29 on page 413](#), [Figure 30-30 on page 414](#) and [Figure 30-31 on page 414](#).

- **RXRDY: Receive Holding Register Ready (automatically set / reset)**

0: No character has been received since the last TWI_RHR read operation.

1: A byte has been received in the TWI_RHR since the last read.

RXRDY behavior in Master mode can be seen in [Figure 30-10 on page 397](#).

RXRDY behavior in Slave mode can be seen in [Figure 30-26 on page 411](#), [Figure 30-29 on page 413](#), [Figure 30-30 on page 414](#) and [Figure 30-31 on page 414](#).

- **TXRDY: Transmit Holding Register Ready (automatically set / reset)**

TXRDY used in Master mode:

0: The transmit holding register has not been transferred into shift register. Set to 0 when writing into TWI_THR.

1: As soon as a data byte is transferred from TWI_THR to internal shifter or if a NACK error is detected, TXRDY is set at the same time as TXCOMP and NACK. TXRDY is also set when MSEN is set (enable TWI).

TXRDY behavior in Master mode can be seen in [Figure 30-8 on page 396](#).

TXRDY used in Slave mode:

0: As soon as data is written in the TWI_THR, until this data has been transmitted and acknowledged (ACK or NACK).

1: It indicates that the TWI_THR is empty and that data has been transmitted and acknowledged.

If TXRDY is high and if a NACK has been detected, the transmission will be stopped. Thus when TRDY = NACK = 1, the programmer must not fill TWI_THR to avoid losing it.

TXRDY behavior in Slave mode can be seen in [Figure 30-25 on page 410](#), [Figure 30-28 on page 412](#), [Figure 30-30 on page 414](#) and [Figure 30-31 on page 414](#).

- **SVREAD: Slave Read (automatically set / reset)**

This bit is only used in Slave mode. When SVACC is low (no Slave access has been detected) SVREAD is irrelevant.

0: Indicates that a write access is performed by a Master.

1: Indicates that a read access is performed by a Master.

SVREAD behavior can be seen in [Figure 30-25 on page 410](#), [Figure 30-26 on page 411](#), [Figure 30-30 on page 414](#) and [Figure 30-31 on page 414](#).

- **SVACC: Slave Access (automatically set / reset)**

This bit is only used in Slave mode.

0: TWI is not addressed. SVACC is automatically cleared after a NACK or a STOP condition is detected.

1: Indicates that the address decoding sequence has matched (A Master has sent SADR). SVACC remains high until a NACK or a STOP condition is detected.

SVACC behavior can be seen in [Figure 30-25 on page 410](#), [Figure 30-26 on page 411](#), [Figure 30-30 on page 414](#) and [Figure 30-31 on page 414](#).

- **GACC: General Call Access (clear on read)**

This bit is only used in Slave mode.

0: No General Call has been detected.

1: A General Call has been detected. After the detection of General Call, if need be, the programmer may acknowledge this access and decode the following bytes and respond according to the value of the bytes.

GACC behavior can be seen in [Figure 30-27 on page 411](#).

- **OVRE: Overrun Error (clear on read)**

This bit is only used in Master mode.

0: TWI_RHR has not been loaded while RXRDY was set

1: TWI_RHR has been loaded while RXRDY was set. Reset by read in TWI_SR when TXCOMP is set.

- **NACK: Not Acknowledged (clear on read)**

NACK used in Master mode:

0: Each data byte has been correctly received by the far-end side TWI slave component.

1: A data byte has not been acknowledged by the slave component. Set at the same time as TXCOMP.

NACK used in Slave Read mode:

0: Each data byte has been correctly received by the Master.

1: In read mode, a data byte has not been acknowledged by the Master. When NACK is set the programmer must not fill TWI_THR even if TXRDY is set, because it means that the Master will stop the data transfer or re initiate it.

Note that in Slave Write mode all data are acknowledged by the TWI.

- **ARBLST: Arbitration Lost (clear on read)**

This bit is only used in Master mode.

0: Arbitration won.

1: Arbitration lost. Another master of the TWI bus has won the multi-master arbitration. TXCOMP is set at the same time.

- **SCLWS: Clock Wait State (automatically set / reset)**

This bit is only used in Slave mode.

0: The clock is not stretched.

1: The clock is stretched. TWI_THR / TWI_RHR buffer is not filled / emptied before the emission / reception of a new character.

SCLWS behavior can be seen in [Figure 30-28 on page 412](#) and [Figure 30-29 on page 413](#).

- **EOSACC: End Of Slave Access (clear on read)**

This bit is only used in Slave mode.

0: A slave access is being performing.

1: The Slave Access is finished. End Of Slave Access is automatically set as soon as SVACC is reset.

EOSACC behavior can be seen in [Figure 30-30 on page 414](#) and [Figure 30-31 on page 414](#)

30.11.7 TWI Interrupt Enable Register

Name: TWI_IER

Address: 0xFFFFAC024

Access: Write-only

| | | | | | | | |
|----|------|------|-------|--------|--------|--------|--------|
| 31 | 30 | 29 | 28 | 27 | 26 | 25 | 24 |
| – | – | – | – | – | – | – | – |
| 23 | 22 | 21 | 20 | 19 | 18 | 17 | 16 |
| – | – | – | – | – | – | – | – |
| 15 | 14 | 13 | 12 | 11 | 10 | 9 | 8 |
| | | | | EOSACC | SCL_WS | ARBLST | NACK |
| 7 | 6 | 5 | 4 | 3 | 2 | 1 | 0 |
| – | OVRE | GACC | SVACC | – | TXRDY | RXRDY | TXCOMP |

- **TXCOMP:** Transmission Completed Interrupt Enable
- **RXRDY:** Receive Holding Register Ready Interrupt Enable
- **TXRDY:** Transmit Holding Register Ready Interrupt Enable
- **SVACC:** Slave Access Interrupt Enable
- **GACC:** General Call Access Interrupt Enable
- **OVRE:** Overrun Error Interrupt Enable
- **NACK:** Not Acknowledge Interrupt Enable
- **ARBLST:** Arbitration Lost Interrupt Enable
- **SCL_WS:** Clock Wait State Interrupt Enable
- **EOSACC:** End Of Slave Access Interrupt Enable

0: No effect.

1: Enables the corresponding interrupt.

30.11.8 TWI Interrupt Disable Register

Name: TWI_IDR

Address: 0xFFFFAC028

Access: Write-only

| | | | | | | | |
|----|------|------|-------|--------|--------|--------|--------|
| 31 | 30 | 29 | 28 | 27 | 26 | 25 | 24 |
| – | – | – | – | – | – | – | – |
| 23 | 22 | 21 | 20 | 19 | 18 | 17 | 16 |
| – | – | – | – | – | – | – | – |
| 15 | 14 | 13 | 12 | 11 | 10 | 9 | 8 |
| | | | | EOSACC | SCL_WS | ARBLST | NACK |
| 7 | 6 | 5 | 4 | 3 | 2 | 1 | 0 |
| – | OVRE | GACC | SVACC | – | TXRDY | RXRDY | TXCOMP |

- **TXCOMP:** Transmission Completed Interrupt Disable
- **RXRDY:** Receive Holding Register Ready Interrupt Disable
- **TXRDY:** Transmit Holding Register Ready Interrupt Disable
- **SVACC:** Slave Access Interrupt Disable
- **GACC:** General Call Access Interrupt Disable
- **OVRE:** Overrun Error Interrupt Disable
- **NACK:** Not Acknowledge Interrupt Disable
- **ARBLST:** Arbitration Lost Interrupt Disable
- **SCL_WS:** Clock Wait State Interrupt Disable
- **EOSACC:** End Of Slave Access Interrupt Disable

0: No effect.

1: Disables the corresponding interrupt.

30.11.9 TWI Interrupt Mask Register

Name: TWI_IMR

Address: 0xFFFFAC02C

Access: Read-only

| | | | | | | | |
|----|------|------|-------|--------|--------|--------|--------|
| 31 | 30 | 29 | 28 | 27 | 26 | 25 | 24 |
| – | – | – | – | – | – | – | – |
| 23 | 22 | 21 | 20 | 19 | 18 | 17 | 16 |
| – | – | – | – | – | – | – | – |
| 15 | 14 | 13 | 12 | 11 | 10 | 9 | 8 |
| | | | | EOSACC | SCL_WS | ARBLST | NACK |
| 7 | 6 | 5 | 4 | 3 | 2 | 1 | 0 |
| – | OVRE | GACC | SVACC | – | TXRDY | RXRDY | TXCOMP |

- **TXCOMP: Transmission Completed Interrupt Mask**
- **RXRDY: Receive Holding Register Ready Interrupt Mask**
- **TXRDY: Transmit Holding Register Ready Interrupt Mask**
- **SVACC: Slave Access Interrupt Mask**
- **GACC: General Call Access Interrupt Mask**
- **OVRE: Overrun Error Interrupt Mask**
- **NACK: Not Acknowledge Interrupt Mask**
- **ARBLST: Arbitration Lost Interrupt Mask**
- **SCL_WS: Clock Wait State Interrupt Mask**
- **EOSACC: End Of Slave Access Interrupt Mask**

0: The corresponding interrupt is disabled.

1: The corresponding interrupt is enabled.

30.11.10TWI Receive Holding Register

Name: TWI_RHR

Address: 0xFFFFAC030

Access: Read-only

| | | | | | | | |
|--------|----|----|----|----|----|----|----|
| 31 | 30 | 29 | 28 | 27 | 26 | 25 | 24 |
| - | - | - | - | - | - | - | - |
| 23 | 22 | 21 | 20 | 19 | 18 | 17 | 16 |
| - | - | - | - | - | - | - | - |
| 15 | 14 | 13 | 12 | 11 | 10 | 9 | 8 |
| - | - | - | - | - | - | - | - |
| 7 | 6 | 5 | 4 | 3 | 2 | 1 | 0 |
| RXDATA | | | | | | | |

- **RXDATA: Master or Slave Receive Holding Data**

30.11.11TWI Transmit Holding Register

Name: TWI_THR

Address: 0xFFFFAC034

Access: Write-only

| | | | | | | | |
|--------|----|----|----|----|----|----|----|
| 31 | 30 | 29 | 28 | 27 | 26 | 25 | 24 |
| - | - | - | - | - | - | - | - |
| 23 | 22 | 21 | 20 | 19 | 18 | 17 | 16 |
| - | - | - | - | - | - | - | - |
| 15 | 14 | 13 | 12 | 11 | 10 | 9 | 8 |
| - | - | - | - | - | - | - | - |
| 7 | 6 | 5 | 4 | 3 | 2 | 1 | 0 |
| TXDATA | | | | | | | |

- TXDATA: Master or Slave Transmit Holding Data

31. Universal Synchronous Asynchronous Receiver Transmitter (USART)

31.1 Overview

The Universal Synchronous Asynchronous Receiver Transceiver (USART) provides one full duplex universal synchronous asynchronous serial link. Data frame format is widely programmable (data length, parity, number of stop bits) to support a maximum of standards. The receiver implements parity error, framing error and overrun error detection. The receiver time-out enables handling variable-length frames and the transmitter timeguard facilitates communications with slow remote devices. Multidrop communications are also supported through address bit handling in reception and transmission.

The USART features three test modes: remote loopback, local loopback and automatic echo.

The USART supports specific operating modes providing interfaces on RS485 buses, with ISO7816 T = 0 or T = 1 smart card slots and infrared transceivers. The hardware handshaking feature enables an out-of-band flow control by automatic management of the pins RTS and CTS.

The USART supports the connection to the Peripheral DMA Controller, which enables data transfers to the transmitter and from the receiver. The PDC provides chained buffer management without any intervention of the processor.

31.2 Block Diagram

Figure 31-1. USART Block Diagram

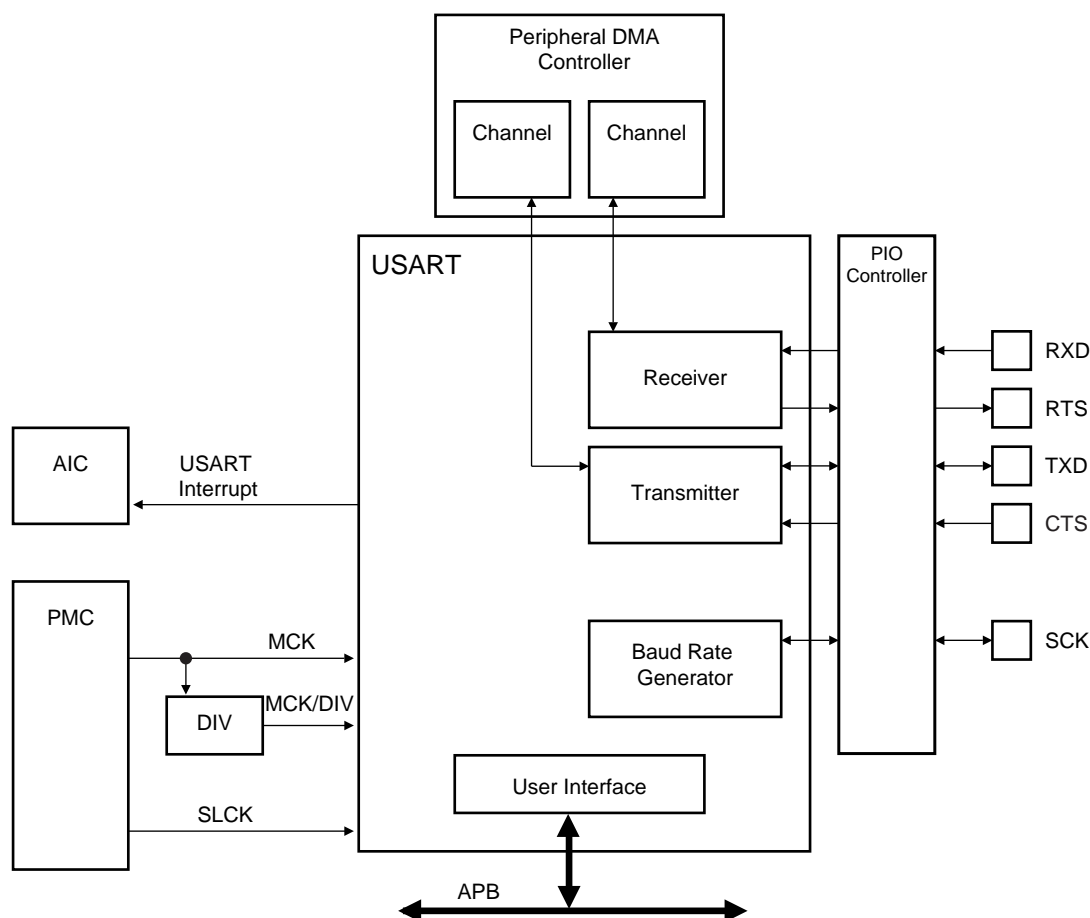

31.3 Application Block Diagram

Figure 31-2. Application Block Diagram

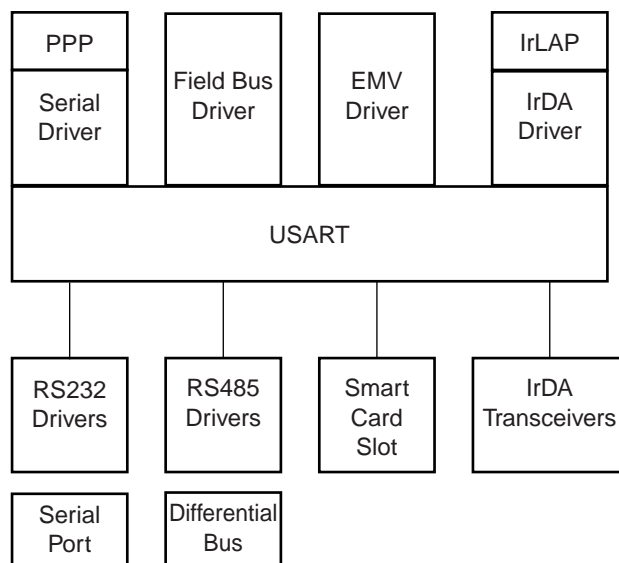

31.4 I/O Lines Description

Table 31-1. I/O Line Description

| Name | Description | Type | Active Level |
|------|----------------------|--------|--------------|
| SCK | Serial Clock | I/O | |
| TXD | Transmit Serial Data | I/O | |
| RXD | Receive Serial Data | Input | |
| CTS | Clear to Send | Input | Low |
| RTS | Request to Send | Output | Low |

31.5 Product Dependencies

31.5.1 I/O Lines

The pins used for interfacing the USART may be multiplexed with the PIO lines. The programmer must first program the PIO controller to assign the desired USART pins to their peripheral function. If I/O lines of the USART are not used by the application, they can be used for other purposes by the PIO Controller.

To prevent the TXD line from falling when the USART is disabled, the use of an internal pull up is mandatory. If the hardware handshaking feature is used, the internal pull up on TXD must also be enabled.

31.5.2 Power Management

The USART is not continuously clocked. The programmer must first enable the USART Clock in the Power Management Controller (PMC) before using the USART. However, if the application does not require USART operations, the USART clock can be stopped when not needed and be restarted later. In this case, the USART will resume its operations where it left off.

Configuring the USART does not require the USART clock to be enabled.

31.5.3 Interrupt

The USART interrupt line is connected on one of the internal sources of the Advanced Interrupt Controller. Using the USART interrupt requires the AIC to be programmed first. Note that it is not recommended to use the USART interrupt line in edge sensitive mode.

31.6 Functional Description

The USART is capable of managing several types of serial synchronous or asynchronous communications.

It supports the following communication modes:

- 5- to 9-bit full-duplex asynchronous serial communication
 - MSB- or LSB-first
 - 1, 1.5 or 2 stop bits
 - Parity even, odd, marked, space or none
 - By 8 or by 16 over-sampling receiver frequency
 - Optional hardware handshaking
 - Optional break management
 - Optional multidrop serial communication
- High-speed 5- to 9-bit full-duplex synchronous serial communication
 - MSB- or LSB-first
 - 1 or 2 stop bits
 - Parity even, odd, marked, space or none
 - By 8 or by 16 over-sampling frequency
 - Optional hardware handshaking
 - Optional break management
 - Optional multidrop serial communication
- RS485 with driver control signal
- ISO7816, T0 or T1 protocols for interfacing with smart cards
 - NACK handling, error counter with repetition and iteration limit
- InfraRed IrDA Modulation and Demodulation
- Test modes
 - Remote loopback, local loopback, automatic echo

31.6.1 Baud Rate Generator

The Baud Rate Generator provides the bit period clock named the Baud Rate Clock to both the receiver and the transmitter.

The Baud Rate Generator clock source can be selected by setting the USCLKS field in the Mode Register (US_MR) between:

- the Master Clock MCK
- a division of the Master Clock, the divider being product dependent, but generally set to 8
- the external clock, available on the SCK pin

The Baud Rate Generator is based upon a 16-bit divider, which is programmed with the CD field of the Baud Rate Generator Register (US_BRGR). If CD is programmed at 0, the Baud Rate Generator does not generate any clock. If CD is programmed at 1, the divider is bypassed and becomes inactive.

If the external SCK clock is selected, the duration of the low and high levels of the signal provided on the SCK pin must be longer than a Master Clock (MCK) period. The frequency of the signal provided on SCK must be at least 4.5 times lower than MCK.

Figure 31-3. Baud Rate Generator

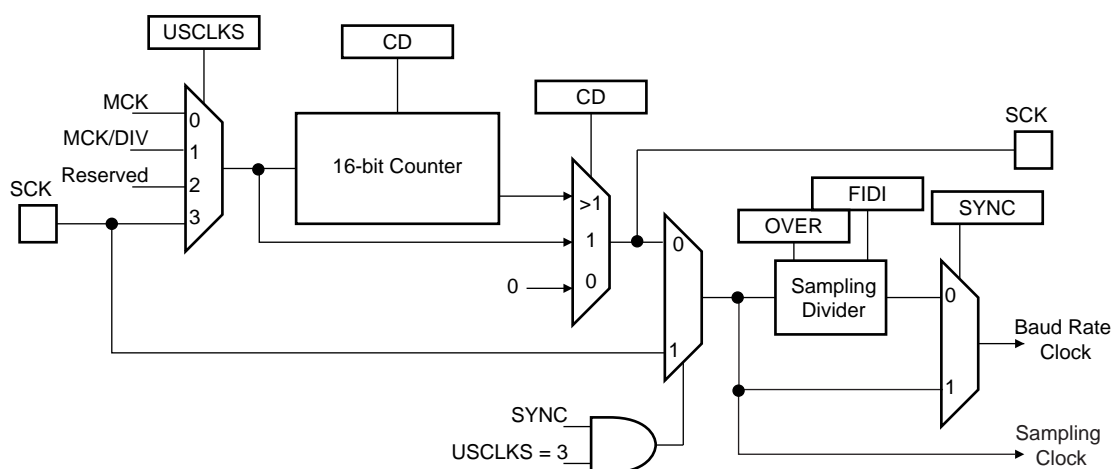

31.6.1.1 Baud Rate in Asynchronous Mode

If the USART is programmed to operate in asynchronous mode, the selected clock is first divided by CD, which is field programmed in the Baud Rate Generator Register (US_BRGR). The resulting clock is provided to the receiver as a sampling clock and then divided by 16 or 8, depending on the programming of the OVER bit in US_MR.

If OVER is set to 1, the receiver sampling is 8 times higher than the baud rate clock. If OVER is cleared, the sampling is performed at 16 times the baud rate clock.

The following formula performs the calculation of the Baud Rate.

$$\text{Baudrate} = \frac{\text{SelectedClock}}{(8(2 - \text{Over})CD)}$$

This gives a maximum baud rate of MCK divided by 8, assuming that MCK is the highest possible clock and that OVER is programmed at 1.

31.6.1.2 Baud Rate Calculation Example

Table 31-2 shows calculations of CD to obtain a baud rate at 38400 bauds for different source clock frequencies. This table also shows the actual resulting baud rate and the error.

Table 31-2. Baud Rate Example (OVER = 0)

| Source Clock (MHz) | Expected Baud Rate (bit/s) | Calculation Result | CD | Actual Baud Rate (bit/s) | Error |
|--------------------|----------------------------|--------------------|----|--------------------------|-------|
| 3 686 400 | 38 400 | 6.00 | 6 | 38 400.00 | 0.00% |
| 4 915 200 | 38 400 | 8.00 | 8 | 38 400.00 | 0.00% |
| 5 000 000 | 38 400 | 8.14 | 8 | 39 062.50 | 1.70% |
| 7 372 800 | 38 400 | 12.00 | 12 | 38 400.00 | 0.00% |
| 8 000 000 | 38 400 | 13.02 | 13 | 38 461.54 | 0.16% |
| 12 000 000 | 38 400 | 19.53 | 20 | 37 500.00 | 2.40% |
| 12 288 000 | 38 400 | 20.00 | 20 | 38 400.00 | 0.00% |
| 14 318 180 | 38 400 | 23.30 | 23 | 38 908.10 | 1.31% |
| 14 745 600 | 38 400 | 24.00 | 24 | 38 400.00 | 0.00% |
| 18 432 000 | 38 400 | 30.00 | 30 | 38 400.00 | 0.00% |
| 24 000 000 | 38 400 | 39.06 | 39 | 38 461.54 | 0.16% |
| 24 576 000 | 38 400 | 40.00 | 40 | 38 400.00 | 0.00% |
| 25 000 000 | 38 400 | 40.69 | 40 | 38 109.76 | 0.76% |
| 32 000 000 | 38 400 | 52.08 | 52 | 38 461.54 | 0.16% |
| 32 768 000 | 38 400 | 53.33 | 53 | 38 641.51 | 0.63% |
| 33 000 000 | 38 400 | 53.71 | 54 | 38 194.44 | 0.54% |
| 40 000 000 | 38 400 | 65.10 | 65 | 38 461.54 | 0.16% |
| 50 000 000 | 38 400 | 81.38 | 81 | 38 580.25 | 0.47% |

The baud rate is calculated with the following formula:

$$BaudRate = MCK / CD \times 16$$

The baud rate error is calculated with the following formula. It is not recommended to work with an error higher than 5%.

$$Error = 1 - \left(\frac{ExpectedBaudRate}{ActualBaudRate} \right)$$

31.6.1.3 Fractional Baud Rate in Asynchronous Mode

The Baud Rate generator previously defined is subject to the following limitation: the output frequency changes by only integer multiples of the reference frequency. An approach to this problem is to integrate a fractional N clock generator that has a high resolution. The generator architecture is modified to obtain Baud Rate changes by a fraction of the reference source clock. This fractional part is programmed with the FP field in the Baud Rate Generator Register (US_BRGR). If FP is not 0, the fractional part is activated. The resolution is one eighth of the clock divider. This feature is only available when using USART normal mode. The fractional Baud Rate is calculated using the following formula:

$$Baudrate = \frac{SelectedClock}{\left(8(2 - Over) \left(CD + \frac{FP}{8} \right) \right)}$$

The modified architecture is presented below:

Figure 31-4. Fractional Baud Rate Generator

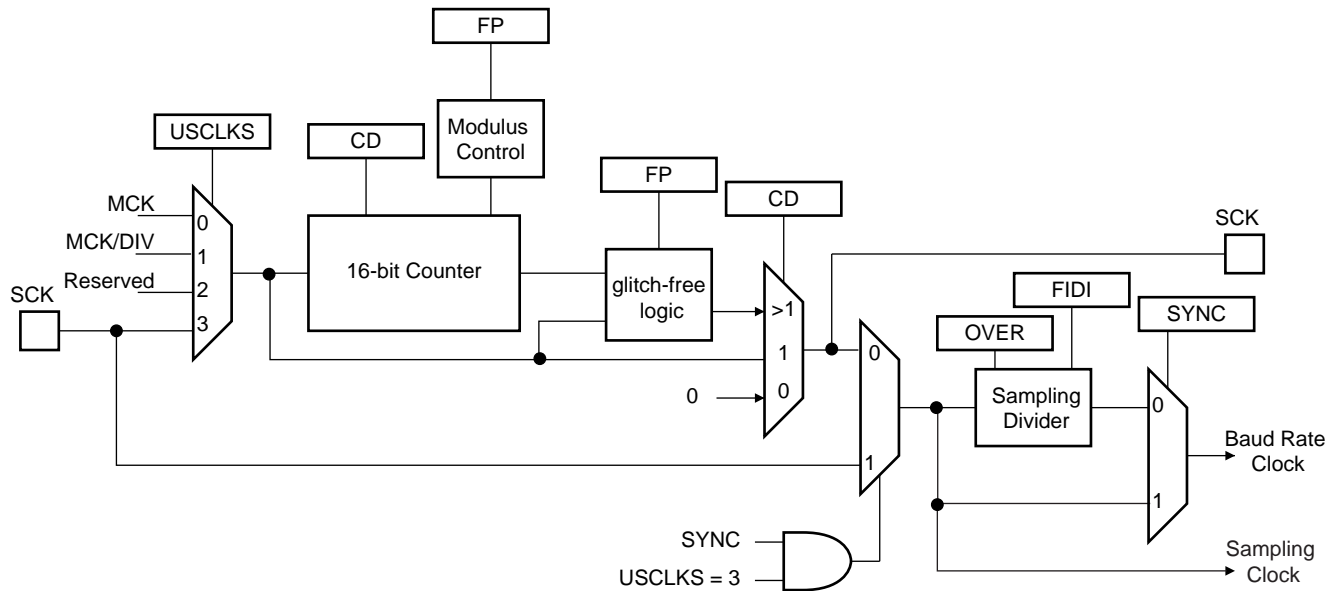

31.6.1.4 Baud Rate in Synchronous Mode

If the USART is programmed to operate in synchronous mode, the selected clock is simply divided by the field CD in US_BRGR.

$$BaudRate = \frac{SelectedClock}{CD}$$

In synchronous mode, if the external clock is selected (USCLKS = 3), the clock is provided directly by the signal on the USART SCK pin. No division is active. The value written in US_BRGR has no effect. The external clock frequency must be at least 4.5 times lower than the system clock.

When either the external clock SCK or the internal clock divided (MCK/DIV) is selected, the value programmed in CD must be even if the user has to ensure a 50:50 mark/space ratio on the SCK pin. If the internal clock MCK is selected, the Baud Rate Generator ensures a 50:50 duty cycle on the SCK pin, even if the value programmed in CD is odd.

31.6.1.5 Baud Rate in ISO 7816 Mode

The ISO7816 specification defines the bit rate with the following formula:

$$B = \frac{D_i}{F_i} \times f$$

where:

- B is the bit rate
- D_i is the bit-rate adjustment factor
- F_i is the clock frequency division factor
- f is the ISO7816 clock frequency (Hz)

D_i is a binary value encoded on a 4-bit field, named DI, as represented in [Table 31-3](#).

Table 31-3. Binary and Decimal Values for DI

| DI field | 0001 | 0010 | 0011 | 0100 | 0101 | 0110 | 1000 | 1001 |
|--------------|------|------|------|------|------|------|------|------|
| Di (decimal) | 1 | 2 | 4 | 8 | 16 | 32 | 12 | 20 |

Fi is a binary value encoded on a 4-bit field, named FI, as represented in [Table 31-4](#).

Table 31-4. Binary and Decimal Values for Fi

| | | | | | | | | | | | | |
|--------------|------|------|------|------|------|------|------|------|------|------|------|------|
| Fi field | 0000 | 0001 | 0010 | 0011 | 0100 | 0101 | 0110 | 1001 | 1010 | 1011 | 1100 | 1101 |
| Fi (decimal) | 372 | 372 | 558 | 744 | 1116 | 1488 | 1860 | 512 | 768 | 1024 | 1536 | 2048 |

[Table 31-5](#) shows the resulting Fi/Di Ratio, which is the ratio between the ISO7816 clock and the baud rate clock.

Table 31-5. Possible Values for the Fi/Di Ratio

| | | | | | | | | | | | |
|-------|-------|-------|-------|-------|------|-------|-------|------|-------|------|-------|
| Fi/Di | 372 | 558 | 744 | 1116 | 1488 | 1806 | 512 | 768 | 1024 | 1536 | 2048 |
| 1 | 372 | 558 | 744 | 1116 | 1488 | 1860 | 512 | 768 | 1024 | 1536 | 2048 |
| 2 | 186 | 279 | 372 | 558 | 744 | 930 | 256 | 384 | 512 | 768 | 1024 |
| 4 | 93 | 139.5 | 186 | 279 | 372 | 465 | 128 | 192 | 256 | 384 | 512 |
| 8 | 46.5 | 69.75 | 93 | 139.5 | 186 | 232.5 | 64 | 96 | 128 | 192 | 256 |
| 16 | 23.25 | 34.87 | 46.5 | 69.75 | 93 | 116.2 | 32 | 48 | 64 | 96 | 128 |
| 32 | 11.62 | 17.43 | 23.25 | 34.87 | 46.5 | 58.13 | 16 | 24 | 32 | 48 | 64 |
| 12 | 31 | 46.5 | 62 | 93 | 124 | 155 | 42.66 | 64 | 85.33 | 128 | 170.6 |
| 20 | 18.6 | 27.9 | 37.2 | 55.8 | 74.4 | 93 | 25.6 | 38.4 | 51.2 | 76.8 | 102.4 |

If the USART is configured in ISO7816 Mode, the clock selected by the USCLKS field in the Mode Register (US_MR) is first divided by the value programmed in the field CD in the Baud Rate Generator Register (US_BRGR). The resulting clock can be provided to the SCK pin to feed the smart card clock inputs. This means that the CLKO bit can be set in US_MR.

This clock is then divided by the value programmed in the FI_DI_RATIO field in the FI_DI_Ratio register (US_FIDI). This is performed by the Sampling Divider, which performs a division by up to 2047 in ISO7816 Mode. The non-integer values of the Fi/Di Ratio are not supported and the user must program the FI_DI_RATIO field to a value as close as possible to the expected value.

The FI_DI_RATIO field resets to the value 0x174 (372 in decimal) and is the most common divider between the ISO7816 clock and the bit rate (Fi = 372, Di = 1).

[Figure 31-5](#) shows the relation between the Elementary Time Unit, corresponding to a bit time, and the ISO 7816 clock.

Figure 31-5. Elementary Time Unit (ETU)

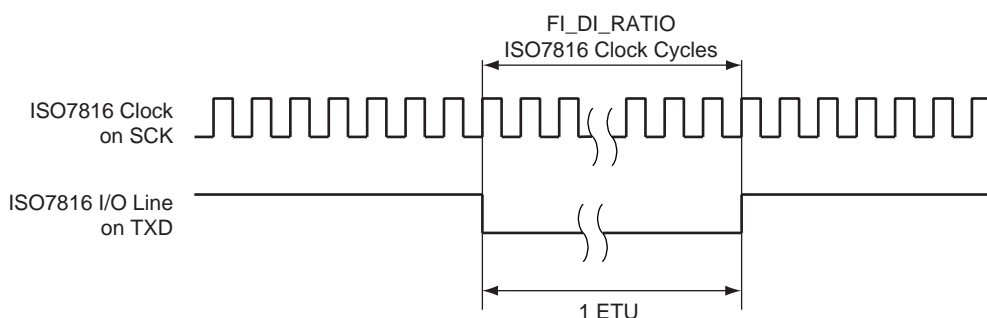

31.6.2 Receiver and Transmitter Control

After reset, the receiver is disabled. The user must enable the receiver by setting the RXEN bit in the Control Register (US_CR). However, the receiver registers can be programmed before the receiver clock is enabled.

After reset, the transmitter is disabled. The user must enable it by setting the TXEN bit in the Control Register (US_CR). However, the transmitter registers can be programmed before being enabled.

The Receiver and the Transmitter can be enabled together or independently.

At any time, the software can perform a reset on the receiver or the transmitter of the USART by setting the corresponding bit, RSTRX and RSTTX respectively, in the Control Register (US_CR). The software resets clear the status flag and reset internal state machines but the user interface configuration registers hold the value configured prior to software reset. Regardless of what the receiver or the transmitter is performing, the communication is immediately stopped.

The user can also independently disable the receiver or the transmitter by setting RXDIS and TXDIS respectively in US_CR. If the receiver is disabled during a character reception, the USART waits until the end of reception of the current character, then the reception is stopped. If the transmitter is disabled while it is operating, the USART waits the end of transmission of both the current character and character being stored in the Transmit Holding Register (US_THR). If a timeguard is programmed, it is handled normally.

31.6.3 Synchronous and Asynchronous Modes

31.6.3.1 Transmitter Operations

The transmitter performs the same in both synchronous and asynchronous operating modes (SYNC = 0 or SYNC = 1). One start bit, up to 9 data bits, one optional parity bit and up to two stop bits are successively shifted out on the TXD pin at each falling edge of the programmed serial clock.

The number of data bits is selected by the CHRL field and the MODE 9 bit in the Mode Register (US_MR). Nine bits are selected by setting the MODE 9 bit regardless of the CHRL field. The parity bit is set according to the PAR field in US_MR. The even, odd, space, marked or none parity bit can be configured. The MSBF field in US_MR configures which data bit is sent first. If written at 1, the most significant bit is sent first. At 0, the less significant bit is sent first. The number of stop bits is selected by the NBSTOP field in US_MR. The 1.5 stop bit is supported in asynchronous mode only.

Figure 31-6. Character Transmit

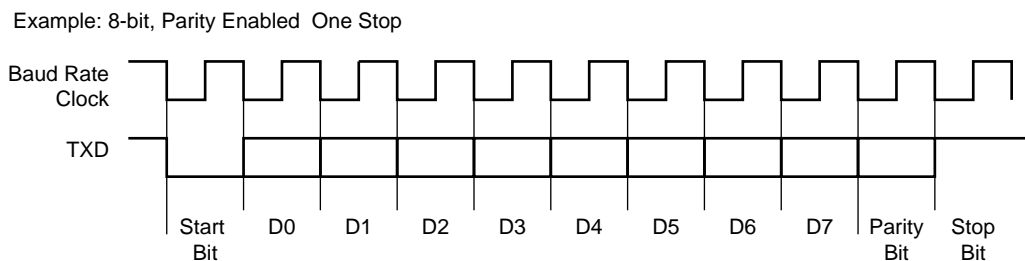

The characters are sent by writing in the Transmit Holding Register (US_THR). The transmitter reports two status bits in the Channel Status Register (US_CSR): TXRDY (Transmitter Ready), which indicates that US_THR is empty and TXEMPTY, which indicates that all the characters written in US_THR have been processed. When the current character processing is completed, the last character written in US_THR is transferred into the Shift Register of the transmitter and US_THR becomes empty, thus TXRDY rises.

Both TXRDY and TXEMPTY bits are low when the transmitter is disabled. Writing a character in US_THR while TXRDY is low has no effect and the written character is lost.

Figure 31-7. Transmitter Status

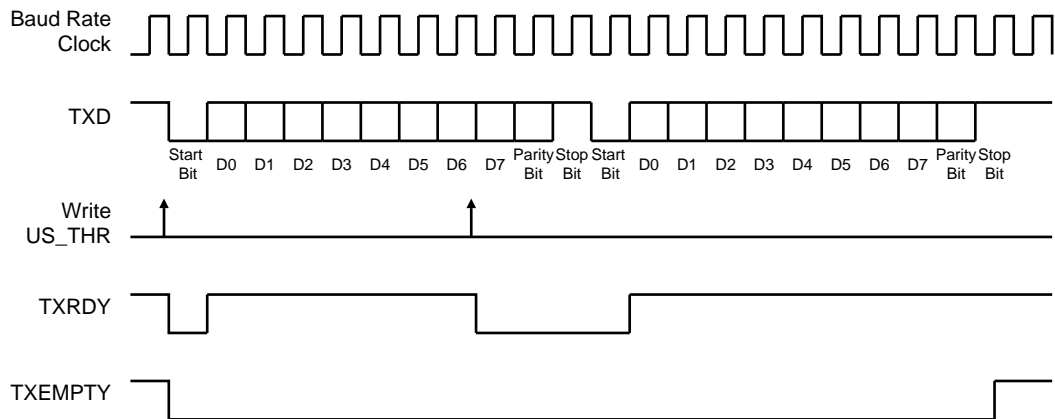

31.6.3.2 Asynchronous Receiver

If the USART is programmed in asynchronous operating mode ($SYNC = 0$), the receiver oversamples the RXD input line. The oversampling is either 16 or 8 times the Baud Rate clock, depending on the OVER bit in the Mode Register (US_MR).

The receiver samples the RXD line. If the line is sampled during one half of a bit time at 0, a start bit is detected and data, parity and stop bits are successively sampled on the bit rate clock.

If the oversampling is 16, (OVER at 0), a start is detected at the eighth sample at 0. Then, data bits, parity bit and stop bit are sampled on each 16 sampling clock cycle. If the oversampling is 8 (OVER at 1), a start bit is detected at the fourth sample at 0. Then, data bits, parity bit and stop bit are sampled on each 8 sampling clock cycle.

The number of data bits, first bit sent and parity mode are selected by the same fields and bits as the transmitter, i.e. respectively CHRL, MODE9, MSBF and PAR. For the synchronization mechanism **only**, the number of stop bits has no effect on the receiver as it considers only one stop bit, regardless of the field NBSTOP, so that resynchronization between the receiver and the transmitter can occur. Moreover, as soon as the stop bit is sampled, the receiver starts looking for a new start bit so that resynchronization can also be accomplished when the transmitter is operating with one stop bit.

Figure 31-8 and Figure 31-9 illustrate start detection and character reception when USART operates in asynchronous mode.

Figure 31-8. Asynchronous Start Detection

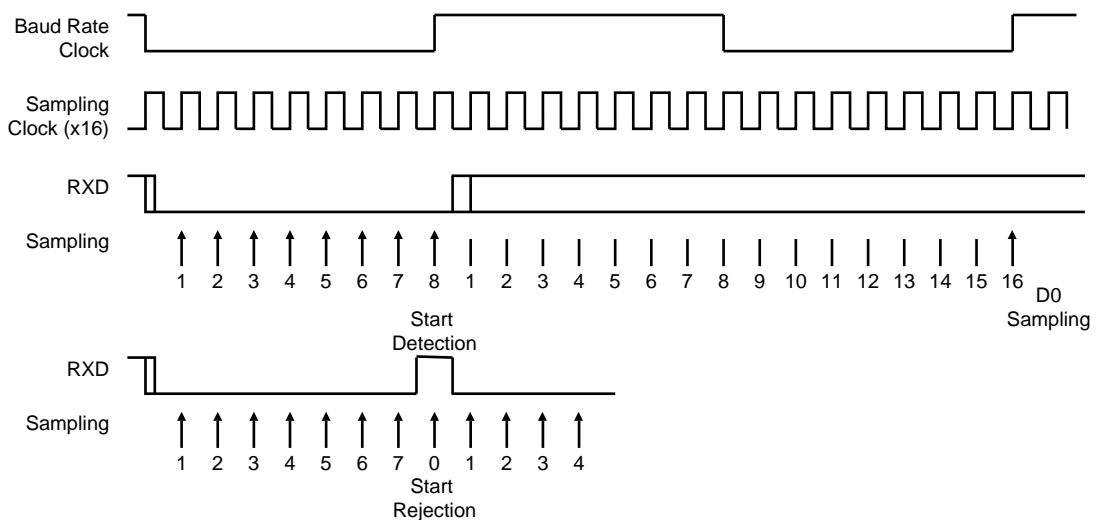
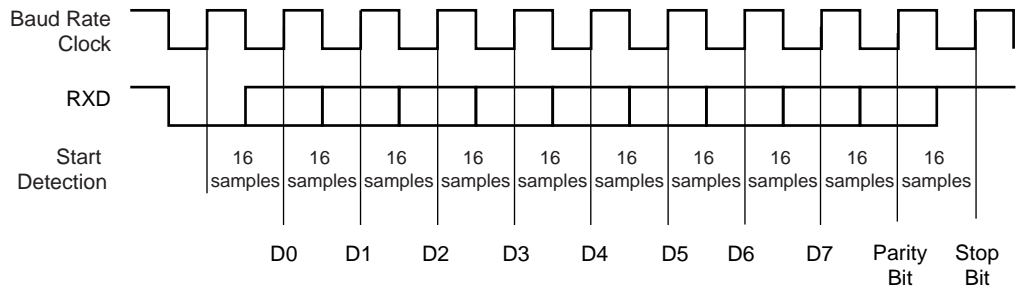

Figure 31-9. Asynchronous Character Reception

Example: 8-bit, Parity Enabled



31.6.3.3 Synchronous Receiver

In synchronous mode ($SYNC = 1$), the receiver samples the RXD signal on each rising edge of the Baud Rate Clock. If a low level is detected, it is considered as a start. All data bits, the parity bit and the stop bits are sampled and the receiver waits for the next start bit. Synchronous mode operations provide a high speed transfer capability. Configuration fields and bits are the same as in asynchronous mode. [Figure 31-10](#) illustrates a character reception in synchronous mode.

Figure 31-10. Synchronous Mode Character Reception

Example: 8-bit, Parity Enabled 1 Stop

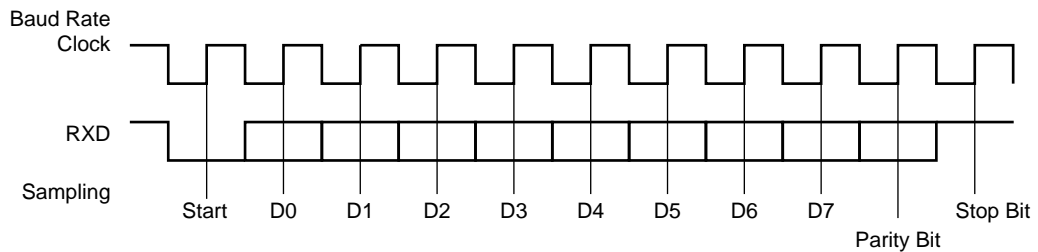

31.6.3.4 Receiver Operations

When a character reception is completed, it is transferred to the Receive Holding Register (US_RHR) and the RXRDY bit in the Status Register (US_CSR) rises. If a character is completed while the RXRDY is set, the OVRE (Overrun Error) bit is set. The last character is transferred into US_RHR and overwrites the previous one. The OVRE bit is cleared by writing the Control Register (US_CR) with the RSTSTA (Reset Status) bit at 1.

Figure 31-11. Receiver Status

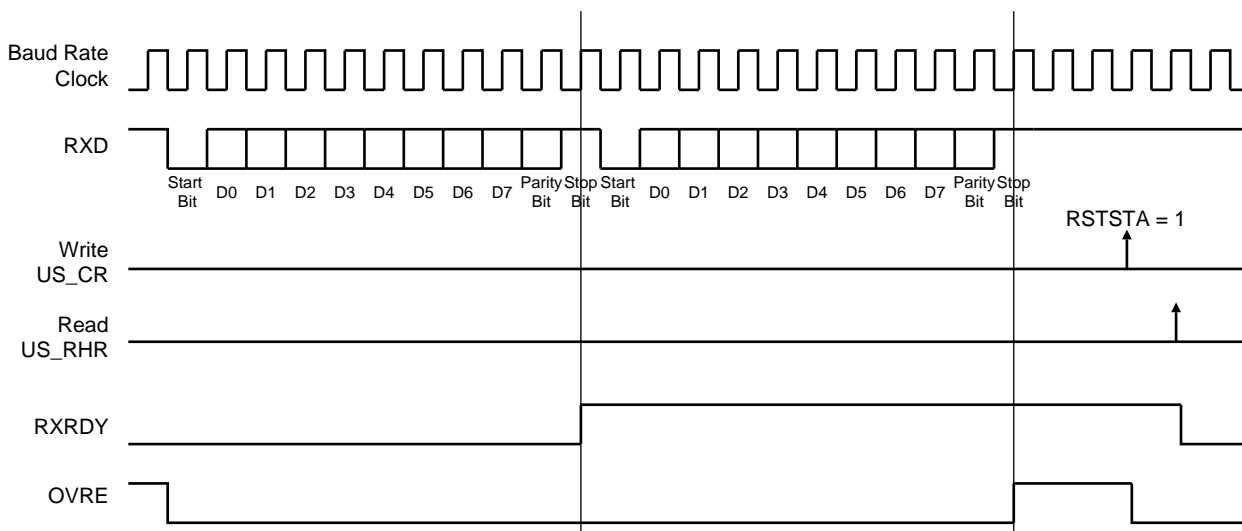

31.6.3.5 Parity

The USART supports five parity modes selected by programming the PAR field in the Mode Register (US_MR). The PAR field also enables the Multidrop mode, see “Multidrop Mode” on page 443. Even and odd parity bit generation and error detection are supported.

If even parity is selected, the parity generator of the transmitter drives the parity bit at 0 if a number of 1s in the character data bit is even, and at 1 if the number of 1s is odd. Accordingly, the receiver parity checker counts the number of received 1s and reports a parity error if the sampled parity bit does not correspond. If odd parity is selected, the parity generator of the transmitter drives the parity bit at 1 if a number of 1s in the character data bit is even, and at 0 if the number of 1s is odd. Accordingly, the receiver parity checker counts the number of received 1s and reports a parity error if the sampled parity bit does not correspond. If the mark parity is used, the parity generator of the transmitter drives the parity bit at 1 for all characters. The receiver parity checker reports an error if the parity bit is sampled at 0. If the space parity is used, the parity generator of the transmitter drives the parity bit at 0 for all characters. The receiver parity checker reports an error if the parity bit is sampled at 1. If parity is disabled, the transmitter does not generate any parity bit and the receiver does not report any parity error.

Table 31-6 shows an example of the parity bit for the character 0x41 (character ASCII “A”) depending on the configuration of the USART. Because there are two bits at 1, 1 bit is added when a parity is odd, or 0 is added when a parity is even.

Table 31-6. Parity Bit Examples

| Character | Hexadecimal | Binary | Parity Bit | Parity Mode |
|-----------|-------------|-----------|------------|-------------|
| A | 0x41 | 0100 0001 | 1 | Odd |
| A | 0x41 | 0100 0001 | 0 | Even |
| A | 0x41 | 0100 0001 | 1 | Mark |
| A | 0x41 | 0100 0001 | 0 | Space |
| A | 0x41 | 0100 0001 | None | None |

When the receiver detects a parity error, it sets the PARE (Parity Error) bit in the Channel Status Register (US_CSR). The PARE bit can be cleared by writing the Control Register (US_CR) with the RSTSTA bit at 1. Figure 31-12 illustrates the parity bit status setting and clearing.

Figure 31-12. Parity Error

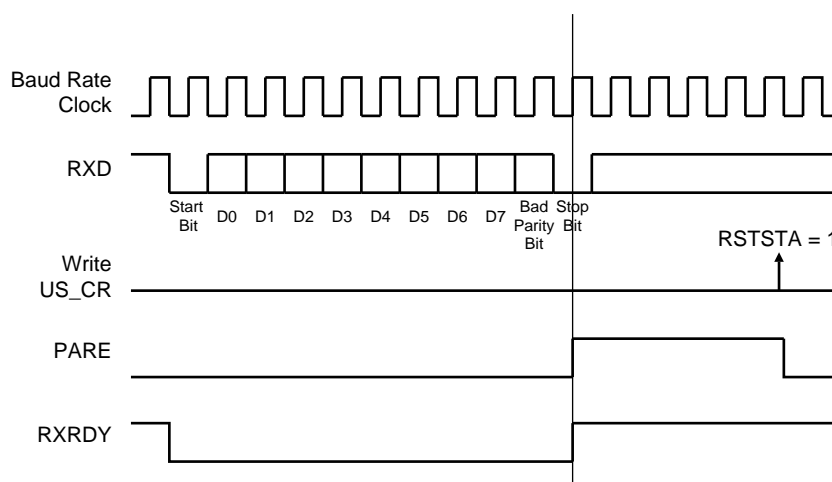

31.6.3.6 Multidrop Mode

If the PAR field in the Mode Register (US_MR) is programmed to the value 0x6 or 0x07, the USART runs in Multidrop Mode. This mode differentiates the data characters and the address characters. Data is transmitted with the parity bit at 0 and addresses are transmitted with the parity bit at 1.

If the USART is configured in multidrop mode, the receiver sets the PARE parity error bit when the parity bit is high and the transmitter is able to send a character with the parity bit high when the Control Register is written with the SENDA bit at 1.

To handle parity error, the PARE bit is cleared when the Control Register is written with the bit RSTSTA at 1.

The transmitter sends an address byte (parity bit set) when SENDA is written to US_CR. In this case, the next byte written to US_THR is transmitted as an address. Any character written in US_THR without having written the command SENDA is transmitted normally with the parity at 0.

31.6.3.7 Transmitter Timeguard

The timeguard feature enables the USART interface with slow remote devices.

The timeguard function enables the transmitter to insert an idle state on the TXD line between two characters. This idle state actually acts as a long stop bit.

The duration of the idle state is programmed in the TG field of the Transmitter Timeguard Register (US_TTGR). When this field is programmed at zero no timeguard is generated. Otherwise, the transmitter holds a high level on TXD after each transmitted byte during the number of bit periods programmed in TG in addition to the number of stop bits.

As illustrated in Figure 31-13, the behavior of TXRDY and TXEMPTY status bits is modified by the programming of a timeguard. TXRDY rises only when the start bit of the next character is sent, and thus remains at 0 during the timeguard transmission if a character has been written in US_THR. TXEMPTY remains low until the timeguard transmission is completed as the timeguard is part of the current character being transmitted.

Figure 31-13. Timeguard Operations

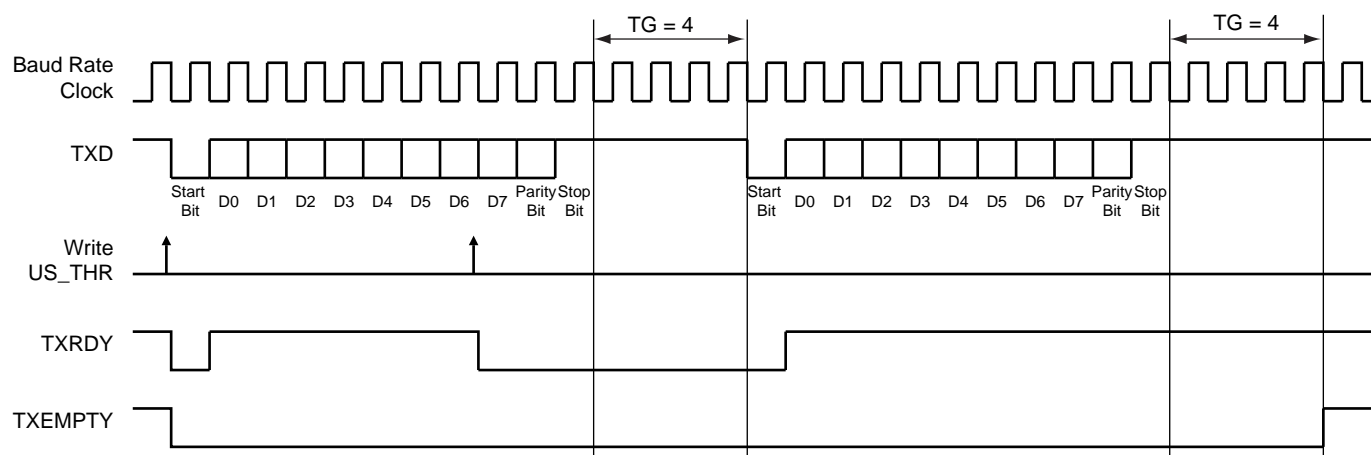

Table 31-7 indicates the maximum length of a timeguard period that the transmitter can handle in relation to the function of the Baud Rate.

Table 31-7. Maximum Timeguard Length Depending on Baud Rate

| Baud Rate (bit/s) | Bit Time (μ s) | Timeguard (ms) |
|-------------------|---------------------|----------------|
| 1 200 | 833 | 212.50 |
| 9 600 | 104 | 26.56 |
| 14400 | 69.4 | 17.71 |

Table 31-7. Maximum Timeguard Length Depending on Baud Rate (Continued)

| Baud Rate (bit/s) | Bit Time (μ s) | Timeguard (ms) |
|-------------------|---------------------|----------------|
| 19200 | 52.1 | 13.28 |
| 28800 | 34.7 | 8.85 |
| 33400 | 29.9 | 7.63 |
| 56000 | 17.9 | 4.55 |
| 57600 | 17.4 | 4.43 |
| 115200 | 8.7 | 2.21 |

31.6.3.8 Receiver Time-out

The Receiver Time-out provides support in handling variable-length frames. This feature detects an idle condition on the RXD line. When a time-out is detected, the bit TIMEOUT in the Channel Status Register (US_CSR) rises and can generate an interrupt, thus indicating to the driver an end of frame.

The time-out delay period (during which the receiver waits for a new character) is programmed in the TO field of the Receiver Time-out Register (US_RTOR). If the TO field is programmed at 0, the Receiver Time-out is disabled and no time-out is detected. The TIMEOUT bit in US_CSR remains at 0. Otherwise, the receiver loads a 16-bit counter with the value programmed in TO. This counter is decremented at each bit period and reloaded each time a new character is received. If the counter reaches 0, the TIMEOUT bit in the Status Register rises. Then, the user can either:

- Stop the counter clock until a new character is received. This is performed by writing the Control Register (US_CR) with the STTTO (Start Time-out) bit at 1. In this case, the idle state on RXD before a new character is received will not provide a time-out. This prevents having to handle an interrupt before a character is received and allows waiting for the next idle state on RXD after a frame is received.
- Obtain an interrupt while no character is received. This is performed by writing US_CR with the RETTO (Reload and Start Time-out) bit at 1. If RETTO is performed, the counter starts counting down immediately from the value TO. This enables generation of a periodic interrupt so that a user time-out can be handled, for example when no key is pressed on a keyboard.

If STTTO is performed, the counter clock is stopped until a first character is received. The idle state on RXD before the start of the frame does not provide a time-out. This prevents having to obtain a periodic interrupt and enables a wait of the end of frame when the idle state on RXD is detected.

If RETTO is performed, the counter starts counting down immediately from the value TO. This enables generation of a periodic interrupt so that a user time-out can be handled, for example when no key is pressed on a keyboard.

Figure 31-14 shows the block diagram of the Receiver Time-out feature.

Figure 31-14. Receiver Time-out Block Diagram

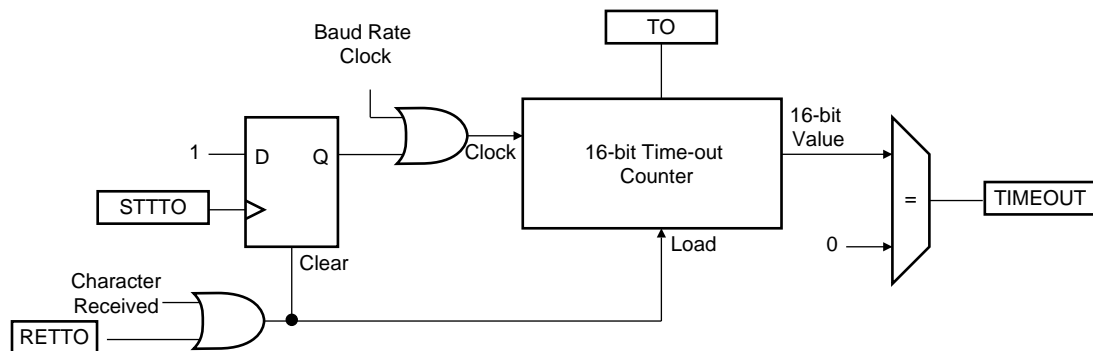

Table 31-8 gives the maximum time-out period for some standard baud rates.

Table 31-8. Maximum Time-out Period

| Baud Rate (bit/s) | Bit Time (μ s) | Time-out (ms) |
|-------------------|---------------------|---------------|
| 600 | 1 667 | 109 225 |
| 1 200 | 833 | 54 613 |
| 2 400 | 417 | 27 306 |
| 4 800 | 208 | 13 653 |
| 9 600 | 104 | 6 827 |
| 14400 | 69 | 4 551 |
| 19200 | 52 | 3 413 |
| 28800 | 35 | 2 276 |
| 33400 | 30 | 1 962 |
| 56000 | 18 | 1 170 |
| 57600 | 17 | 1 138 |
| 200000 | 5 | 328 |

31.6.3.9 Framing Error

The receiver is capable of detecting framing errors. A framing error happens when the stop bit of a received character is detected at level 0. This can occur if the receiver and the transmitter are fully desynchronized.

A framing error is reported on the FRAME bit of the Channel Status Register (US_CSR). The FRAME bit is asserted in the middle of the stop bit as soon as the framing error is detected. It is cleared by writing the Control Register (US_CR) with the RSTSTA bit at 1.

Figure 31-15. Framing Error Status

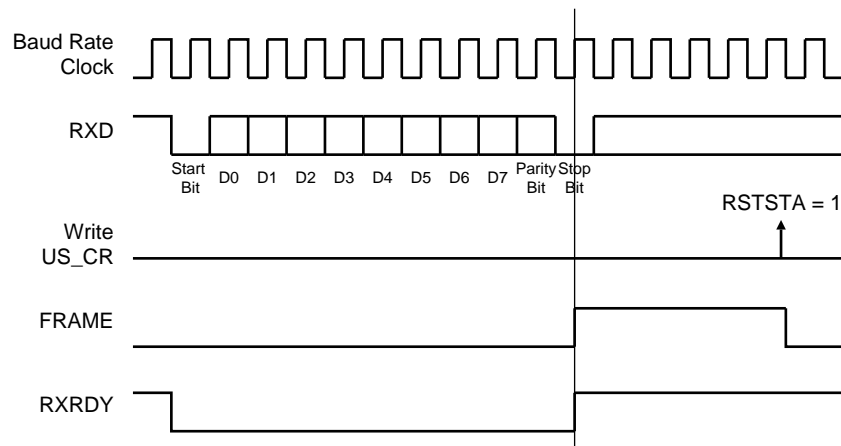

31.6.3.10 Transmit Break

The user can request the transmitter to generate a break condition on the TXD line. A break condition drives the TXD line low during at least one complete character. It appears the same as a 0x00 character sent with the parity and the stop bits at 0. However, the transmitter holds the TXD line at least during one character until the user requests the break condition to be removed.

A break is transmitted by writing the Control Register (US_CR) with the STTBRK bit at 1. This can be performed at any time, either while the transmitter is empty (no character in either the Shift Register or in US_THR) or when a

character is being transmitted. If a break is requested while a character is being shifted out, the character is first completed before the TXD line is held low.

Once STTBRK command is requested further STTBRK commands are ignored until the end of the break is completed.

The break condition is removed by writing US_CR with the STPBRK bit at 1. If the STPBRK is requested before the end of the minimum break duration (one character, including start, data, parity and stop bits), the transmitter ensures that the break condition completes.

The transmitter considers the break as though it is a character, i.e. the STTBRK and STPBRK commands are taken into account only if the TXRDY bit in US_CSR is at 1 and the start of the break condition clears the TXRDY and TXEMPTY bits as if a character is processed.

Writing US_CR with the both STTBRK and STPBRK bits at 1 can lead to an unpredictable result. All STPBRK commands requested without a previous STTBRK command are ignored. A byte written into the Transmit Holding Register while a break is pending, but not started, is ignored.

After the break condition, the transmitter returns the TXD line to 1 for a minimum of 12 bit times. Thus, the transmitter ensures that the remote receiver detects correctly the end of break and the start of the next character. If the timeguard is programmed with a value higher than 12, the TXD line is held high for the timeguard period.

After holding the TXD line for this period, the transmitter resumes normal operations.

Figure 31-16 illustrates the effect of both the Start Break (STTBRK) and Stop Break (STPBRK) commands on the TXD line.

Figure 31-16. Break Transmission

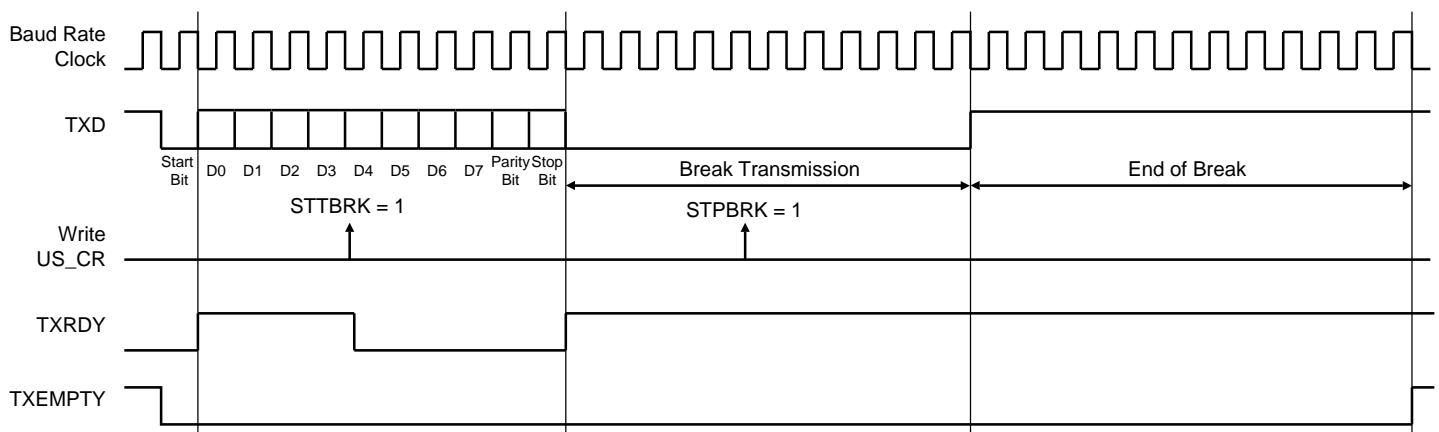

31.6.3.11 Receive Break

The receiver detects a break condition when all data, parity and stop bits are low. This corresponds to detecting a framing error with data at 0x00, but FRAME remains low.

When the low stop bit is detected, the receiver asserts the RXBRK bit in US_CSR. This bit may be cleared by writing the Control Register (US_CR) with the bit RSTSTA at 1.

An end of receive break is detected by a high level for at least 2/16 of a bit period in asynchronous operating mode or one sample at high level in synchronous operating mode. The end of break detection also asserts the RXBRK bit.

31.6.3.12 Hardware Handshaking

The USART features a hardware handshaking out-of-band flow control. The RTS and CTS pins are used to connect with the remote device, as shown in [Figure 31-17](#).

Figure 31-17. Connection with a Remote Device for Hardware Handshaking

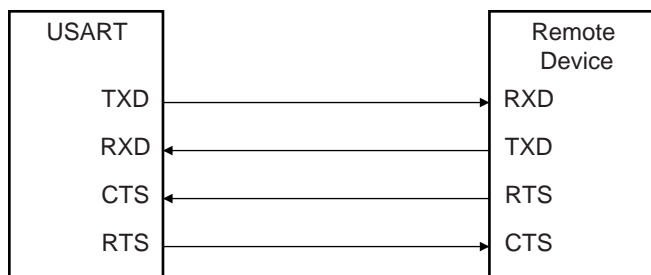

Setting the USART to operate with hardware handshaking is performed by writing the USART_MODE field in the Mode Register (US_MR) to the value 0x2.

The USART behavior when hardware handshaking is enabled is the same as the behavior in standard synchronous or asynchronous mode, except that the receiver drives the RTS pin as described below and the level on the CTS pin modifies the behavior of the transmitter as described below. Using this mode requires using the PDC channel for reception. The transmitter can handle hardware handshaking in any case.

[Figure 31-18](#) shows how the receiver operates if hardware handshaking is enabled. The RTS pin is driven high if the receiver is disabled and if the status RXBUFF (Receive Buffer Full) coming from the PDC channel is high. Normally, the remote device does not start transmitting while its CTS pin (driven by RTS) is high. As soon as the Receiver is enabled, the RTS falls, indicating to the remote device that it can start transmitting. Defining a new buffer to the PDC clears the status bit RXBUFF and, as a result, asserts the pin RTS low.

Figure 31-18. Receiver Behavior when Operating with Hardware Handshaking

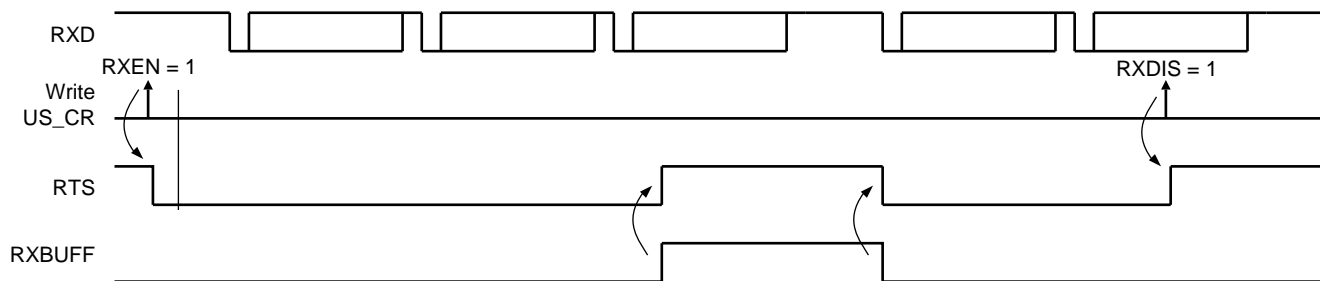

[Figure 31-19](#) shows how the transmitter operates if hardware handshaking is enabled. The CTS pin disables the transmitter. If a character is being processing, the transmitter is disabled only after the completion of the current character and transmission of the next character happens as soon as the pin CTS falls.

Figure 31-19. Transmitter Behavior when Operating with Hardware Handshaking



31.6.4 ISO7816 Mode

The USART features an ISO7816-compatible operating mode. This mode permits interfacing with smart cards and Security Access Modules (SAM) communicating through an ISO7816 link. Both T = 0 and T = 1 protocols defined by the ISO7816 specification are supported.

Setting the USART in ISO7816 mode is performed by writing the USART_MODE field in the Mode Register (US_MR) to the value 0x4 for protocol T = 0 and to the value 0x5 for protocol T = 1.

31.6.4.1 ISO7816 Mode Overview

The ISO7816 is a half duplex communication on only one bidirectional line. The baud rate is determined by a division of the clock provided to the remote device (see [“Baud Rate Generator” on page 434](#)).

The USART connects to a smart card as shown in [Figure 31-20](#). The TXD line becomes bidirectional and the Baud Rate Generator feeds the ISO7816 clock on the SCK pin. As the TXD pin becomes bidirectional, its output remains driven by the output of the transmitter but only when the transmitter is active while its input is directed to the input of the receiver. The USART is considered as the master of the communication as it generates the clock.

Figure 31-20. Connection of a Smart Card to the USART

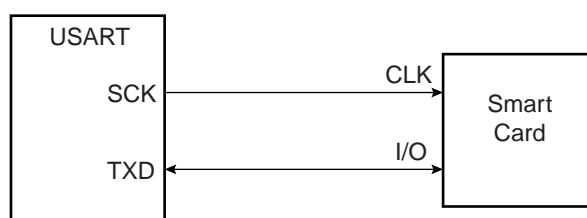

When operating in ISO7816, either in T = 0 or T = 1 modes, the character format is fixed. The configuration is 8 data bits, even parity and 1 or 2 stop bits, regardless of the values programmed in the CHRL, MODE9, PAR and CHMODE fields. MSBF can be used to transmit LSB or MSB first. Parity Bit (PAR) can be used to transmit in normal or inverse mode. Refer to [“USART Mode Register” on page 459](#) and [“PAR: Parity Type” on page 460](#).

The USART cannot operate concurrently in both receiver and transmitter modes as the communication is unidirectional at a time. It has to be configured according to the required mode by enabling or disabling either the receiver or the transmitter as desired. Enabling both the receiver and the transmitter at the same time in ISO7816 mode may lead to unpredictable results.

The ISO7816 specification defines an inverse transmission format. Data bits of the character must be transmitted on the I/O line at their negative value. The USART does not support this format and the user has to perform an exclusive OR on the data before writing it in the Transmit Holding Register (US_THR) or after reading it in the Receive Holding Register (US_RHR).

31.6.4.2 Protocol T = 0

In T = 0 protocol, a character is made up of one start bit, eight data bits, one parity bit and one guard time, which lasts two bit times. The transmitter shifts out the bits and does not drive the I/O line during the guard time.

If no parity error is detected, the I/O line remains at 1 during the guard time and the transmitter can continue with the transmission of the next character, as shown in [Figure 31-21](#).

If a parity error is detected by the receiver, it drives the I/O line at 0 during the guard time, as shown in [Figure 31-22](#). This error bit is also named NACK, for Non Acknowledge. In this case, the character lasts 1 bit time more, as the guard time length is the same and is added to the error bit time which lasts 1 bit time.

When the USART is the receiver and it detects an error, it does not load the erroneous character in the Receive Holding Register (US_RHR). It appropriately sets the PARE bit in the Status Register (US_SR) so that the software can handle the error.

Figure 31-21. T = 0 Protocol without Parity Error

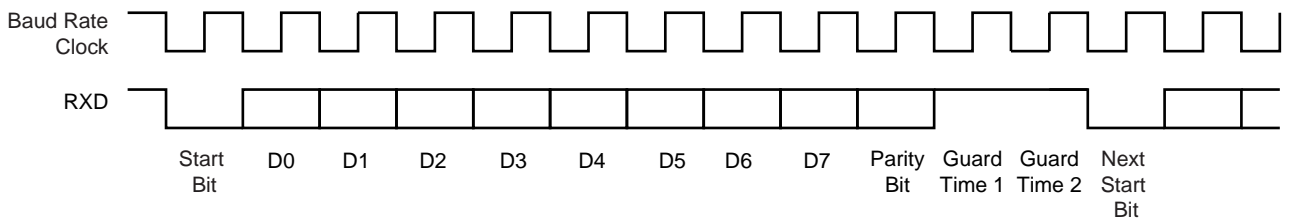
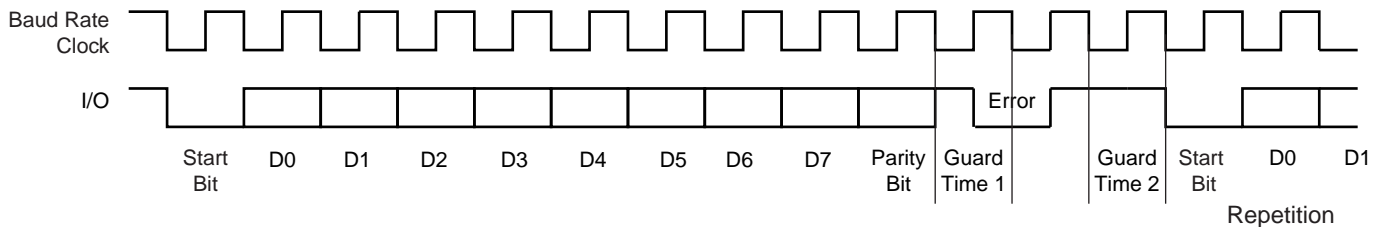

Figure 31-22. T = 0 Protocol with Parity Error



31.6.4.3 Receive Error Counter

The USART receiver also records the total number of errors. This can be read in the Number of Error (US_NER) register. The NB_ERRORS field can record up to 255 errors. Reading US_NER automatically clears the NB_ERRORS field.

31.6.4.4 Receive NACK Inhibit

The USART can also be configured to inhibit an error. This can be achieved by setting the INACK bit in the Mode Register (US_MR). If INACK is at 1, no error signal is driven on the I/O line even if a parity bit is detected, but the INACK bit is set in the Status Register (US_SR). The INACK bit can be cleared by writing the Control Register (US_CR) with the RSTNACK bit at 1.

Moreover, if INACK is set, the erroneous received character is stored in the Receive Holding Register, as if no error occurred. However, the RXRDY bit does not raise.

31.6.4.5 Transmit Character Repetition

When the USART is transmitting a character and gets a NACK, it can automatically repeat the character before moving on to the next one. Repetition is enabled by writing the MAX_ITERATION field in the Mode Register (US_MR) at a value higher than 0. Each character can be transmitted up to eight times; the first transmission plus seven repetitions.

If MAX_ITERATION does not equal zero, the USART repeats the character as many times as the value loaded in MAX_ITERATION.

When the USART repetition number reaches MAX_ITERATION, the ITERATION bit is set in the Channel Status Register (US_CSR). If the repetition of the character is acknowledged by the receiver, the repetitions are stopped and the iteration counter is cleared.

The ITERATION bit in US_CSR can be cleared by writing the Control Register with the RSIT bit at 1.

31.6.4.6 Disable Successive Receive NACK

The receiver can limit the number of successive NACKs sent back to the remote transmitter. This is programmed by setting the bit DSNACK in the Mode Register (US_MR). The maximum number of NACK transmitted is programmed in the MAX_ITERATION field. As soon as MAX_ITERATION is reached, the character is considered as correct, an acknowledge is sent on the line and the ITERATION bit in the Channel Status Register is set.

31.6.4.7 Protocol T = 1

When operating in ISO7816 protocol T = 1, the transmission is similar to an asynchronous format with only one stop bit. The parity is generated when transmitting and checked when receiving. Parity error detection sets the PARE bit in the Channel Status Register (US_CSR).

31.6.5 IrDA Mode

The USART features an IrDA mode supplying half-duplex point-to-point wireless communication. It embeds the modulator and demodulator which allows a glueless connection to the infrared transceivers, as shown in [Figure 31-23](#). The modulator and demodulator are compliant with the IrDA specification version 1.1 and support data transfer speeds ranging from 2.4 kbit/s to 115.2 kbit/s.

The USART IrDA mode is enabled by setting the USART_MODE field in the Mode Register (US_MR) to the value 0x8. The IrDA Filter Register (US_IF) allows configuring the demodulator filter. The USART transmitter and receiver operate in a normal asynchronous mode and all parameters are accessible. Note that the modulator and the demodulator are activated.

Figure 31-23. Connection to IrDA Transceivers

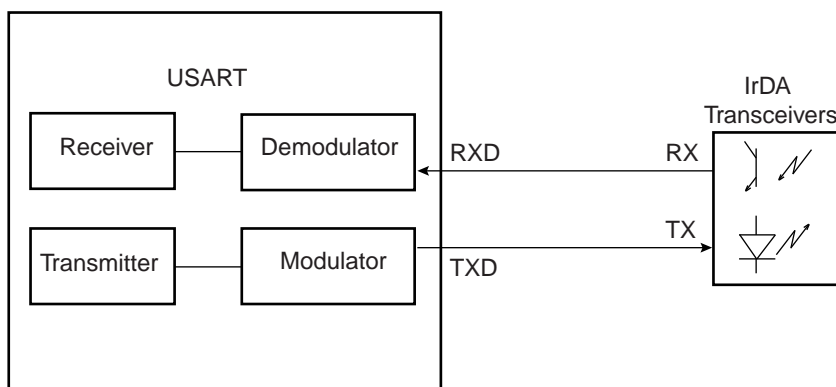

The receiver and the transmitter must be enabled or disabled according to the direction of the transmission to be managed.

To receive IrDA signals the following needs to be done:

- Disable TX and Enable RX
- Configure the TXD pin as PIO and set it as an output at 0 (to avoid LED emission). Disable the internal pull-up (better for power consumption).
- Receive data

31.6.5.1 IrDA Modulation

For baud rates up to and including 115.2 kbit/s, the RZI modulation scheme is used. “0” is represented by a light pulse of 3/16th of a bit time. Some examples of signal pulse duration are shown in [Table 31-9](#).

Table 31-9. IrDA Pulse Duration

| Baud Rate | Pulse Duration (3/16) |
|--------------|-----------------------|
| 2.4 kbit/s | 78.13 μ s |
| 9.6 kbit/s | 19.53 μ s |
| 19.2 kbit/s | 9.77 μ s |
| 38.4 kbit/s | 4.88 μ s |
| 57.6 kbit/s | 3.26 μ s |
| 115.2 kbit/s | 1.63 μ s |

[Figure 31-24](#) shows an example of character transmission.

Figure 31-24. IrDA Modulation

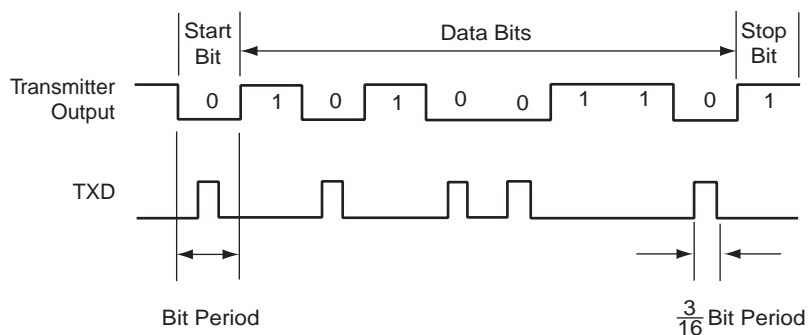

31.6.5.2 IrDA Baud Rate

Table 31-10 gives some examples of CD values, baud rate error and pulse duration. Note that the requirement on the maximum acceptable error of $\pm 1.87\%$ must be met.

Table 31-10. IrDA Baud Rate Error

| Peripheral Clock | Baud Rate (bit/s) | CD | Baud Rate Error | Pulse Time (μ s) |
|------------------|-------------------|-----|-----------------|-----------------------|
| 3 686 400 | 115 200 | 2 | 0.00% | 1.63 |
| 20 000 000 | 115 200 | 11 | 1.38% | 1.63 |
| 32 768 000 | 115 200 | 18 | 1.25% | 1.63 |
| 40 000 000 | 115 200 | 22 | 1.38% | 1.63 |
| 3 686 400 | 57 600 | 4 | 0.00% | 3.26 |
| 20 000 000 | 57 600 | 22 | 1.38% | 3.26 |
| 32 768 000 | 57 600 | 36 | 1.25% | 3.26 |
| 40 000 000 | 57 600 | 43 | 0.93% | 3.26 |
| 3 686 400 | 38 400 | 6 | 0.00% | 4.88 |
| 20 000 000 | 38 400 | 33 | 1.38% | 4.88 |
| 32 768 000 | 38 400 | 53 | 0.63% | 4.88 |
| 40 000 000 | 38 400 | 65 | 0.16% | 4.88 |
| 3 686 400 | 19 200 | 12 | 0.00% | 9.77 |
| 20 000 000 | 19 200 | 65 | 0.16% | 9.77 |
| 32 768 000 | 19 200 | 107 | 0.31% | 9.77 |
| 40 000 000 | 19 200 | 130 | 0.16% | 9.77 |
| 3 686 400 | 9 600 | 24 | 0.00% | 19.53 |
| 20 000 000 | 9 600 | 130 | 0.16% | 19.53 |
| 32 768 000 | 9 600 | 213 | 0.16% | 19.53 |
| 40 000 000 | 9 600 | 260 | 0.16% | 19.53 |
| 3 686 400 | 2 400 | 96 | 0.00% | 78.13 |
| 20 000 000 | 2 400 | 521 | 0.03% | 78.13 |
| 32 768 000 | 2 400 | 853 | 0.04% | 78.13 |

31.6.5.3 IrDA Demodulator

The demodulator is based on the IrDA Receive filter comprised of an 8-bit down counter which is loaded with the value programmed in US_IF. When a falling edge is detected on the RXD pin, the Filter Counter starts counting down at the Master Clock (MCK) speed. If a rising edge is detected on the RXD pin, the counter stops and is reloaded with US_IF. If no rising edge is detected when the counter reaches 0, the input of the receiver is driven low during one bit time.

Figure 31-25 illustrates the operations of the IrDA demodulator.

Figure 31-25. IrDA Demodulator Operations

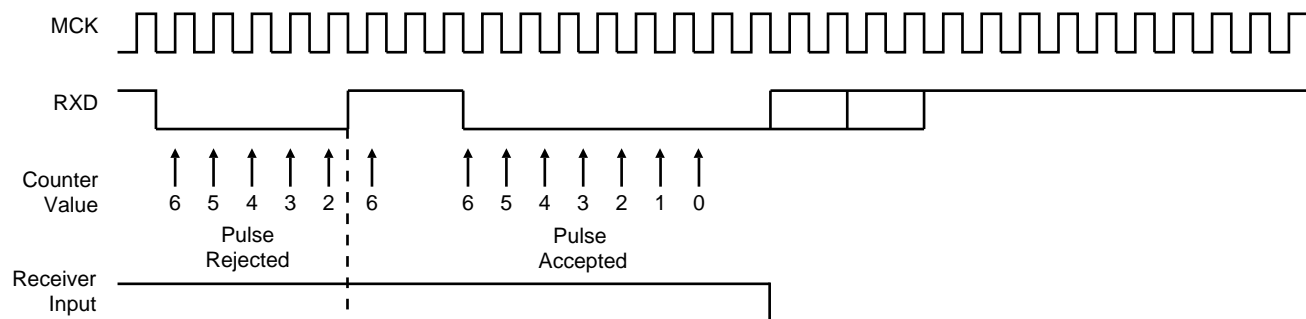

As the IrDA mode uses the same logic as the ISO7816, note that the FI_DI_RATIO field in US_FIDI must be set to a value higher than 0 in order to assure IrDA communications operate correctly.

31.6.6 RS485 Mode

The USART features the RS485 mode to enable line driver control. While operating in RS485 mode, the USART behaves as though in asynchronous or synchronous mode and configuration of all the parameters is possible. The difference is that the RTS pin is driven high when the transmitter is operating. The behavior of the RTS pin is controlled by the TXEMPTY bit. A typical connection of the USART to a RS485 bus is shown in Figure 31-26.

Figure 31-26. Typical Connection to a RS485 Bus

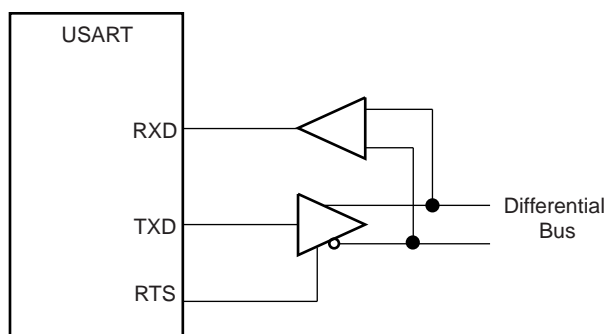

The USART is set in RS485 mode by programming the USART_MODE field in the Mode Register (US_MR) to the value 0x1.

The RTS pin is at a level inverse to the TXEMPTY bit. Significantly, the RTS pin remains high when a timeguard is programmed so that the line can remain driven after the last character completion. Figure 31-27 gives an example of the RTS waveform during a character transmission when the timeguard is enabled.

Figure 31-27. Example of RTS Drive with Timeguard

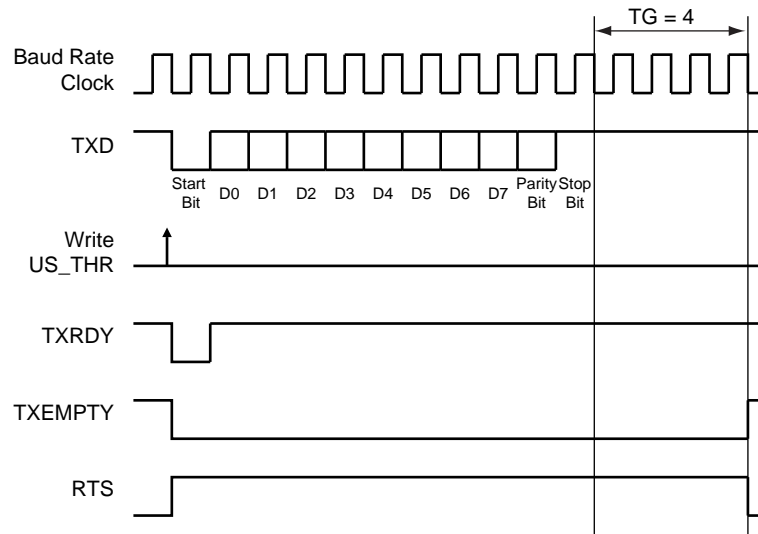

31.6.7 Test Modes

The USART can be programmed to operate in three different test modes. The internal loopback capability allows on-board diagnostics. In the loopback mode the USART interface pins are disconnected or not and reconfigured for loopback internally or externally.

31.6.7.1 Normal Mode

Normal mode connects the RXD pin on the receiver input and the transmitter output on the TXD pin.

Figure 31-28. Normal Mode Configuration

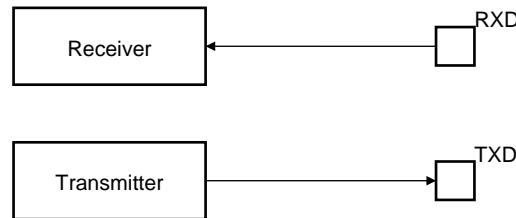

31.6.7.2 Automatic Echo Mode

Automatic echo mode allows bit-by-bit retransmission. When a bit is received on the RXD pin, it is sent to the TXD pin, as shown in [Figure 31-29](#). Programming the transmitter has no effect on the TXD pin. The RXD pin is still connected to the receiver input, thus the receiver remains active.

Figure 31-29. Automatic Echo Mode Configuration

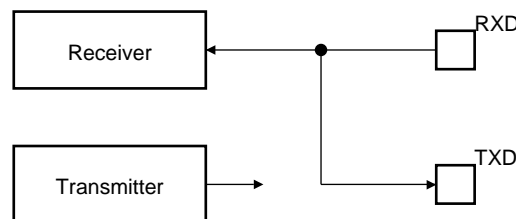

31.6.7.3 Local Loopback Mode

Local loopback mode connects the output of the transmitter directly to the input of the receiver, as shown in [Figure 31-30](#). The TXD and RXD pins are not used. The RXD pin has no effect on the receiver and the TXD pin is continuously driven high, as in idle state.

Figure 31-30. Local Loopback Mode Configuration

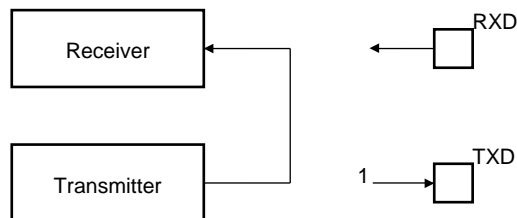

31.6.7.4 Remote Loopback Mode

Remote loopback mode directly connects the RXD pin to the TXD pin, as shown in [Figure 31-31](#). The transmitter and the receiver are disabled and have no effect. This mode allows bit-by-bit retransmission.

Figure 31-31. Remote Loopback Mode Configuration

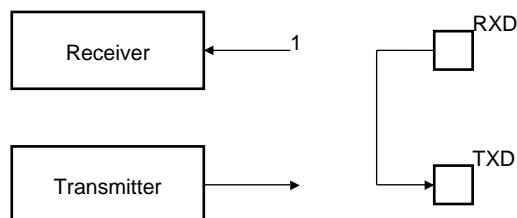

31.7 Universal Synchronous Asynchronous Receiver Transmitter (USART) User Interface

Table 31-11. Register Mapping

| Offset | Register | Name | Access | Reset |
|-------------|--------------------------------|---------|------------|-------|
| 0x0000 | Control Register | US_CR | Write-only | – |
| 0x0004 | Mode Register | US_MR | Read/Write | 0x0 |
| 0x0008 | Interrupt Enable Register | US_IER | Write-only | – |
| 0x000C | Interrupt Disable Register | US_IDR | Write-only | – |
| 0x0010 | Interrupt Mask Register | US_IMR | Read-only | 0x0 |
| 0x0014 | Channel Status Register | US_CSR | Read-only | 0x0 |
| 0x0018 | Receiver Holding Register | US_RHR | Read-only | 0x0 |
| 0x001C | Transmitter Holding Register | US_THR | Write-only | – |
| 0x0020 | Baud Rate Generator Register | US_BRGR | Read/Write | 0x0 |
| 0x0024 | Receiver Time-out Register | US_RTOR | Read/Write | 0x0 |
| 0x0028 | Transmitter Timeguard Register | US_TTGR | Read/Write | 0x0 |
| 0x2C–0x3C | Reserved | – | – | – |
| 0x0040 | FI DI Ratio Register | US_FIDI | Read/Write | 0x174 |
| 0x0044 | Number of Errors Register | US_NER | Read-only | 0x0 |
| 0x0048 | Reserved | – | – | – |
| 0x004C | IrDA Filter Register | US_IF | Read/Write | 0x0 |
| 0x5C–0xFC | Reserved | – | – | – |
| 0x100–0x128 | Reserved for PDC Registers | – | – | – |

31.7.1 USART Control Register

Name: US_CR

Address: 0xFFFFB0000 (0), 0xFFFFB4000 (1), 0xFFFFB8000 (2)

Access: Write-only

| | | | | | | | |
|-------|---------|-------|-------|--------|--------|--------|--------|
| 31 | 30 | 29 | 28 | 27 | 26 | 25 | 24 |
| – | – | – | – | – | – | – | – |
| 23 | 22 | 21 | 20 | 19 | 18 | 17 | 16 |
| – | – | – | – | RTSDIS | RTSEN | – | – |
| 15 | 14 | 13 | 12 | 11 | 10 | 9 | 8 |
| RETTO | RSTNACK | RSTIT | SENDA | STTTO | STPBRK | STTBRK | RSTSTA |
| 7 | 6 | 5 | 4 | 3 | 2 | 1 | 0 |
| TXDIS | TXEN | RXDIS | RXEN | RSTTX | RSTRX | – | – |

- **RSTRX: Reset Receiver**

0: No effect.

1: Resets the receiver.

- **RSTTX: Reset Transmitter**

0: No effect.

1: Resets the transmitter.

- **RXEN: Receiver Enable**

0: No effect.

1: Enables the receiver, if RXDIS is 0.

- **RXDIS: Receiver Disable**

0: No effect.

1: Disables the receiver.

- **TXEN: Transmitter Enable**

0: No effect.

1: Enables the transmitter if TXDIS is 0.

- **TXDIS: Transmitter Disable**

0: No effect.

1: Disables the transmitter.

- **RSTSTA: Reset Status Bits**

0: No effect.

1: Resets the status bits PARE, FRAME, OVRE and RXBRK in US_CSR.

- **STTBRK: Start Break**

0: No effect.

1: Starts transmission of a break after the characters present in US_THR and the Transmit Shift Register have been transmitted. No effect if a break is already being transmitted.

- **STPBRK: Stop Break**

0: No effect.

1: Stops transmission of the break after a minimum of one character length and transmits a high level during 12-bit periods. No effect if no break is being transmitted.

- **STTTO: Start Time-out**

0: No effect.

1: Starts waiting for a character before clocking the time-out counter. Resets the status bit TIMEOUT in US_CSR.

- **SENDA: Send Address**

0: No effect.

1: In Multidrop Mode only, the next character written to the US_THR is sent with the address bit set.

- **RSTIT: Reset Iterations**

0: No effect.

1: Resets ITERATION in US_CSR. No effect if the ISO7816 is not enabled.

- **RSTNACK: Reset Non Acknowledge**

0: No effect

1: Resets NACK in US_CSR.

- **RETTO: Rearm Time-out**

0: No effect

1: Restart Time-out

- **RTSEN: Request to Send Enable**

0: No effect.

1: Drives the pin RTS to 0.

- **RTSDIS: Request to Send Disable**

0: No effect.

1: Drives the pin RTS to 1.

31.7.2 USART Mode Register

Name: US_MR

Address: 0xFFFFB0004 (0), 0xFFFFB4004 (1), 0xFFFFB8004 (2)

Access: Read/Write

| | | | | | | | |
|--------|----|--------|--------|------------|---------------|-------|------|
| 31 | 30 | 29 | 28 | 27 | 26 | 25 | 24 |
| – | – | – | FILTER | – | MAX_ITERATION | | |
| 23 | 22 | 21 | 20 | 19 | 18 | 17 | 16 |
| – | – | DSNACK | INACK | OVER | CLKO | MODE9 | MSBF |
| 15 | 14 | 13 | 12 | 11 | 10 | 9 | 8 |
| CHMODE | | NBSTOP | | PAR | | | SYNC |
| 7 | 6 | 5 | 4 | 3 | 2 | 1 | 0 |
| CHRL | | USCLKS | | USART_MODE | | | |

• USART_MODE

| Value | | | | Mode of the USART |
|--------|---|---|---|-------------------------|
| 0 | 0 | 0 | 0 | Normal |
| 0 | 0 | 0 | 1 | RS485 |
| 0 | 0 | 1 | 0 | Hardware Handshaking |
| 0 | 1 | 0 | 0 | IS07816 Protocol: T = 0 |
| 0 | 1 | 1 | 0 | IS07816 Protocol: T = 1 |
| 1 | 0 | 0 | 0 | IrDA |
| Others | | | | Reserved |

• USCLKS: Clock Selection

| Value | | Selected Clock |
|-------|---|-------------------|
| 0 | 0 | MCK |
| 0 | 1 | MCK/DIV (DIV = 8) |
| 1 | 0 | Reserved |
| 1 | 1 | SCK |

• CHRL: Character Length.

| Value | | Character Length |
|-------|---|------------------|
| 0 | 0 | 5 bits |
| 0 | 1 | 6 bits |
| 1 | 0 | 7 bits |
| 1 | 1 | 8 bits |

• SYNC: Synchronous Mode Select

0: USART operates in Asynchronous Mode.

1: USART operates in Synchronous Mode.

- **PAR: Parity Type**

| Value | | | Parity Type |
|-------|---|---|----------------------------|
| 0 | 0 | 0 | Even parity |
| 0 | 0 | 1 | Odd parity |
| 0 | 1 | 0 | Parity forced to 0 (Space) |
| 0 | 1 | 1 | Parity forced to 1 (Mark) |
| 1 | 0 | x | No parity |
| 1 | 1 | x | Multidrop mode |

- **NBSTOP: Number of Stop Bits**

| Value | | Asynchronous (SYNC = 0) | Synchronous (SYNC = 1) |
|-------|---|-------------------------|------------------------|
| 0 | 0 | 1 stop bit | 1 stop bit |
| 0 | 1 | 1.5 stop bits | Reserved |
| 1 | 0 | 2 stop bits | 2 stop bits |
| 1 | 1 | Reserved | Reserved |

- **CHMODE: Channel Mode**

| Value | | Mode Description |
|-------|---|--|
| 0 | 0 | Normal Mode |
| 0 | 1 | Automatic Echo. Receiver input is connected to the TXD pin. |
| 1 | 0 | Local Loopback. Transmitter output is connected to the Receiver Input. |
| 1 | 1 | Remote Loopback. RXD pin is internally connected to the TXD pin. |

- **MSBF: Bit Order**

0: Least Significant Bit is sent/received first.

1: Most Significant Bit is sent/received first.

- **MODE9: 9-bit Character Length**

0: CHRL defines character length.

1: 9-bit character length.

- **CLKO: Clock Output Select**

0: The USART does not drive the SCK pin.

1: The USART drives the SCK pin if USCLKS does not select the external clock SCK.

- **OVER: Oversampling Mode**

0: 16x Oversampling.

1: 8x Oversampling.

- **INACK: Inhibit Non Acknowledge**

0: The NACK is generated.

1: The NACK is not generated.

- **DSNACK: Disable Successive NACK**

0: NACK is sent on the ISO line as soon as a parity error occurs in the received character (unless INACK is set).

1: Successive parity errors are counted up to the value specified in the MAX_ITERATION field. These parity errors generate a NACK on the ISO line. As soon as this value is reached, no additional NACK is sent on the ISO line. The flag ITERATION is asserted.

- **MAX_ITERATION**

Defines the maximum number of iterations in mode ISO7816, protocol T= 0.

- **FILTER: Infrared Receive Line Filter**

0: The USART does not filter the receive line.

1: The USART filters the receive line using a three-sample filter (1/16-bit clock) (2 over 3 majority).

31.7.3 USART Interrupt Enable Register

Name: US_IER

Address: 0xFFFFB0008 (0), 0xFFFFB4008 (1), 0xFFFFB8008 (2)

Access: Write-only

| | | | | | | | |
|------|-------|------|--------|--------|-------|---------|---------|
| 31 | 30 | 29 | 28 | 27 | 26 | 25 | 24 |
| – | – | – | – | – | – | – | – |
| 23 | 22 | 21 | 20 | 19 | 18 | 17 | 16 |
| – | – | – | – | CTSIC | – | – | – |
| 15 | 14 | 13 | 12 | 11 | 10 | 9 | 8 |
| – | – | NACK | RXBUFF | TXBUFE | ITER | TXEMPTY | TIMEOUT |
| 7 | 6 | 5 | 4 | 3 | 2 | 1 | 0 |
| PARE | FRAME | OVRE | ENDTX | ENDRX | RXBRK | TXRDY | RXRDY |

- **RXRDY: RXRDY Interrupt Enable**
- **TXRDY: TXRDY Interrupt Enable**
- **RXBRK: Receiver Break Interrupt Enable**
- **ENDRX: End of Receive Transfer Interrupt Enable**
- **ENDTX: End of Transmit Interrupt Enable**
- **OVRE: Overrun Error Interrupt Enable**
- **FRAME: Framing Error Interrupt Enable**
- **PARE: Parity Error Interrupt Enable**
- **TIMEOUT: Time-out Interrupt Enable**
- **TXEMPTY: TXEMPTY Interrupt Enable**
- **ITER: Iteration Interrupt Enable**
- **TXBUFE: Buffer Empty Interrupt Enable**
- **RXBUFF: Buffer Full Interrupt Enable**
- **NACK: Non Acknowledge Interrupt Enable**
- **CTSIC: Clear to Send Input Change Interrupt Enable**

31.7.4 USART Interrupt Disable Register

Name: US_IDR

Address: 0xFFFFB000C (0), 0xFFFFB400C (1), 0xFFFFB800C (2)

Access: Write-only

| | | | | | | | |
|------|-------|------|--------|--------|-------|---------|---------|
| 31 | 30 | 29 | 28 | 27 | 26 | 25 | 24 |
| – | – | – | – | – | – | – | – |
| 23 | 22 | 21 | 20 | 19 | 18 | 17 | 16 |
| – | – | – | – | CTSIC | – | – | – |
| 15 | 14 | 13 | 12 | 11 | 10 | 9 | 8 |
| – | – | NACK | RXBUFF | TXBUFE | ITER | TXEMPTY | TIMEOUT |
| 7 | 6 | 5 | 4 | 3 | 2 | 1 | 0 |
| PARE | FRAME | OVRE | ENDTX | ENDRX | RXBRK | TXRDY | RXRDY |

- **RXRDY: RXRDY Interrupt Disable**
- **TXRDY: TXRDY Interrupt Disable**
- **RXBRK: Receiver Break Interrupt Disable**
- **ENDRX: End of Receive Transfer Interrupt Disable**
- **ENDTX: End of Transmit Interrupt Disable**
- **OVRE: Overrun Error Interrupt Disable**
- **FRAME: Framing Error Interrupt Disable**
- **PARE: Parity Error Interrupt Disable**
- **TIMEOUT: Time-out Interrupt Disable**
- **TXEMPTY: TXEMPTY Interrupt Disable**
- **ITER: Iteration Interrupt Enable**
- **TXBUFE: Buffer Empty Interrupt Disable**
- **RXBUFF: Buffer Full Interrupt Disable**
- **NACK: Non Acknowledge Interrupt Disable**
- **CTSIC: Clear to Send Input Change Interrupt Disable**

31.7.5 USART Interrupt Mask Register

Name: US_IMR

Address: 0xFFFFB0010 (0), 0xFFFFB4010 (1), 0xFFFFB8010 (2)

Access: Read-only

| | | | | | | | |
|------|-------|------|--------|--------|-------|---------|---------|
| 31 | 30 | 29 | 28 | 27 | 26 | 25 | 24 |
| – | – | – | – | – | – | – | – |
| 23 | 22 | 21 | 20 | 19 | 18 | 17 | 16 |
| – | – | – | – | CTSIC | – | – | – |
| 15 | 14 | 13 | 12 | 11 | 10 | 9 | 8 |
| – | – | NACK | RXBUFF | TXBUFE | ITER | TXEMPTY | TIMEOUT |
| 7 | 6 | 5 | 4 | 3 | 2 | 1 | 0 |
| PARE | FRAME | OVRE | ENDTX | ENDRX | RXBRK | TXRDY | RXRDY |

- **RXRDY: RXRDY Interrupt Mask**
- **TXRDY: TXRDY Interrupt Mask**
- **RXBRK: Receiver Break Interrupt Mask**
- **ENDRX: End of Receive Transfer Interrupt Mask**
- **ENDTX: End of Transmit Interrupt Mask**
- **OVRE: Overrun Error Interrupt Mask**
- **FRAME: Framing Error Interrupt Mask**
- **PARE: Parity Error Interrupt Mask**
- **TIMEOUT: Time-out Interrupt Mask**
- **TXEMPTY: TXEMPTY Interrupt Mask**
- **ITER: Iteration Interrupt Enable**
- **TXBUFE: Buffer Empty Interrupt Mask**
- **RXBUFF: Buffer Full Interrupt Mask**
- **NACK: Non Acknowledge Interrupt Mask**
- **CTSIC: Clear to Send Input Change Interrupt Mask**

31.7.6 USART Channel Status Register

Name: US_CSR

Address: 0xFFFFB0014 (0), 0xFFFFB4014 (1), 0xFFFFB8014 (2)

Access: Read-only

| | | | | | | | |
|------|-------|------|--------|--------|-------|---------|---------|
| 31 | 30 | 29 | 28 | 27 | 26 | 25 | 24 |
| – | – | – | – | – | – | – | – |
| 23 | 22 | 21 | 20 | 19 | 18 | 17 | 16 |
| CTS | – | – | – | CTSIC | – | – | – |
| 15 | 14 | 13 | 12 | 11 | 10 | 9 | 8 |
| – | – | NACK | RXBUFF | TXBUFE | ITER | TXEMPTY | TIMEOUT |
| 7 | 6 | 5 | 4 | 3 | 2 | 1 | 0 |
| PARE | FRAME | OVRE | ENDTX | ENDRX | RXBRK | TXRDY | RXRDY |

- **RXRDY: Receiver Ready**

0: No complete character has been received since the last read of US_RHR or the receiver is disabled. If characters were being received when the receiver was disabled, RXRDY changes to 1 when the receiver is enabled.

1: At least one complete character has been received and US_RHR has not yet been read.

- **TXRDY: Transmitter Ready**

0: A character is in the US_THR waiting to be transferred to the Transmit Shift Register, or an STTBRK command has been requested, or the transmitter is disabled. As soon as the transmitter is enabled, TXRDY becomes 1.

1: There is no character in the US_THR.

- **RXBRK: Break Received/End of Break**

0: No Break received or End of Break detected since the last RSTSTA.

1: Break Received or End of Break detected since the last RSTSTA.

- **ENDRX: End of Receiver Transfer**

0: The End of Transfer signal from the Receive PDC channel is inactive.

1: The End of Transfer signal from the Receive PDC channel is active.

- **ENDTX: End of Transmitter Transfer**

0: The End of Transfer signal from the Transmit PDC channel is inactive.

1: The End of Transfer signal from the Transmit PDC channel is active.

- **OVRE: Overrun Error**

0: No overrun error has occurred since the last RSTSTA.

1: At least one overrun error has occurred since the last RSTSTA.

- **FRAME: Framing Error**

0: No stop bit has been detected low since the last RSTSTA.

1: At least one stop bit has been detected low since the last RSTSTA.

- **PARE: Parity Error**

0: No parity error has been detected since the last RSTSTA.

1: At least one parity error has been detected since the last RSTSTA.

- **TIMEOUT: Receiver Time-out**

0: There has not been a time-out since the last Start Time-out command (STTTO in US_CR) or the Time-out Register is 0.

1: There has been a time-out since the last Start Time-out command (STTTO in US_CR).

- **TXEMPTY: Transmitter Empty**

0: There are characters in either US_THR or the Transmit Shift Register, or the transmitter is disabled.

1: There are no characters in US_THR, nor in the Transmit Shift Register.

- **ITER: Max number of Repetitions Reached**

0: Maximum number of repetitions has not been reached since the last RSTSTA.

1: Maximum number of repetitions has been reached since the last RSTSTA.

- **TXBUFE: Transmission Buffer Empty**

0: The signal Buffer Empty from the Transmit PDC channel is inactive.

1: The signal Buffer Empty from the Transmit PDC channel is active.

- **RXBUFF: Reception Buffer Full**

0: The signal Buffer Full from the Receive PDC channel is inactive.

1: The signal Buffer Full from the Receive PDC channel is active.

- **NACK: Non Acknowledge**

0: No Non Acknowledge has not been detected since the last RSTNACK.

1: At least one Non Acknowledge has been detected since the last RSTNACK.

- **CTSIC: Clear to Send Input Change Flag**

0: No input change has been detected on the CTS pin since the last read of US_CSR.

1: At least one input change has been detected on the CTS pin since the last read of US_CSR.

- **CTS: Image of CTS Input**

0: CTS is at 0.

1: CTS is at 1.

31.7.7 USART Receive Holding Register

Name: US_RHR

Address: 0xFFFFB0018 (0), 0xFFFFB4018 (1), 0xFFFFB8018 (2)

Access: Read-only

| | | | | | | | |
|--------|----|----|----|----|----|----|-------|
| 31 | 30 | 29 | 28 | 27 | 26 | 25 | 24 |
| – | – | – | – | – | – | – | – |
| 23 | 22 | 21 | 20 | 19 | 18 | 17 | 16 |
| – | – | – | – | – | – | – | – |
| 15 | 14 | 13 | 12 | 11 | 10 | 9 | 8 |
| RXSYNH | – | – | – | – | – | – | RXCHR |
| 7 | 6 | 5 | 4 | 3 | 2 | 1 | 0 |
| RXCHR | | | | | | | |

- **RXCHR: Received Character**

Last character received if RXRDY is set.

- **RXSYNH: Received Sync**

0: Last Character received is a Data.

1: Last Character received is a Command.

31.7.8 USART Transmit Holding Register

Name: US_THR

Address: 0xFFFFB001C (0), 0xFFFFB401C (1), 0xFFFFB801C (2)

Access: Write-only

| | | | | | | | |
|--------|----|----|----|----|----|----|-------|
| 31 | 30 | 29 | 28 | 27 | 26 | 25 | 24 |
| – | – | – | – | – | – | – | – |
| 23 | 22 | 21 | 20 | 19 | 18 | 17 | 16 |
| – | – | – | – | – | – | – | – |
| 15 | 14 | 13 | 12 | 11 | 10 | 9 | 8 |
| TXSYNH | – | – | – | – | – | – | TXCHR |
| 7 | 6 | 5 | 4 | 3 | 2 | 1 | 0 |
| TXCHR | | | | | | | |

- **TXCHR: Character to be Transmitted**

Next character to be transmitted after the current character if TXRDY is not set.

- **TXSYNH: Sync Field to be transmitted**

0: The next character sent is encoded as a data. Start Frame Delimiter is DATA SYNC.

1: The next character sent is encoded as a command. Start Frame Delimiter is COMMAND SYNC.

31.7.9 USART Baud Rate Generator Register

Name: US_BRGR

Address: 0xFFFFB0020 (0), 0xFFFFB4020 (1), 0xFFFFB8020 (2)

Access: Read/Write

| | | | | | | | |
|----|----|----|----|----|-----|----|----|
| 31 | 30 | 29 | 28 | 27 | 26 | 25 | 24 |
| – | – | – | – | – | – | – | – |
| 23 | 22 | 21 | 20 | 19 | 18 | 17 | 16 |
| – | – | – | – | – | FP– | | |
| 15 | 14 | 13 | 12 | 11 | 10 | 9 | 8 |
| CD | | | | | | | |
| 7 | 6 | 5 | 4 | 3 | 2 | 1 | 0 |
| CD | | | | | | | |

• **CD: Clock Divider**

| Value | USART_MODE ≠ ISO7816 | | | USART_MODE = ISO7816 |
|------------|-------------------------------------|------------------------------------|-----------------------------------|--|
| | SYNC = 0 | | SYNC = 1 | |
| | OVER = 0 | OVER = 1 | | |
| 0 | Baud Rate Clock Disabled | | | |
| 1 to 65535 | Baud Rate = Selected Clock/16/CD | Baud Rate = Selected Clock/8/CD | Baud Rate = Selected Clock /CD | Baud Rate = Selected Clock/CD/FI_DI_RATIO |

• **FP: Fractional Part**

0: Fractional divider is disabled.

1–7: Baudrate resolution, defined by $FP \times 1/8$.

31.7.10 USART Receiver Time-out Register

Name: US_RTOR

Address: 0xFFFFB0024 (0), 0xFFFFB4024 (1), 0xFFFFB8024 (2)

Access: Read/Write

| | | | | | | | |
|----|----|----|----|----|----|----|----|
| 31 | 30 | 29 | 28 | 27 | 26 | 25 | 24 |
| – | – | – | – | – | – | – | – |
| 23 | 22 | 21 | 20 | 19 | 18 | 17 | 16 |
| – | – | – | – | – | – | – | – |
| 15 | 14 | 13 | 12 | 11 | 10 | 9 | 8 |
| TO | | | | | | | |
| 7 | 6 | 5 | 4 | 3 | 2 | 1 | 0 |
| TO | | | | | | | |

- **TO: Time-out Value**

0: The Receiver Time-out is disabled.

1–65535: The Receiver Time-out is enabled and the Time-out delay is TO x Bit Period.

31.7.11 USART Transmitter Timeguard Register

Name: US_TTGR

Address: 0xFFFFB0028 (0), 0xFFFFB4028 (1), 0xFFFFB8028 (2)

Access: Read/Write

| | | | | | | | |
|----|----|----|----|----|----|----|----|
| 31 | 30 | 29 | 28 | 27 | 26 | 25 | 24 |
| – | – | – | – | – | – | – | – |
| 23 | 22 | 21 | 20 | 19 | 18 | 17 | 16 |
| – | – | – | – | – | – | – | – |
| 15 | 14 | 13 | 12 | 11 | 10 | 9 | 8 |
| – | – | – | – | – | – | – | – |
| 7 | 6 | 5 | 4 | 3 | 2 | 1 | 0 |
| TG | | | | | | | |

- **TG: Timeguard Value**

0: The Transmitter Timeguard is disabled.

1–255: The Transmitter timeguard is enabled and the timeguard delay is TG x Bit Period.

31.7.12 USART FI DI RATIO Register

Name: US_FIDI

Address: 0xFFFFB0040 (0), 0xFFFFB4040 (1), 0xFFFFB8040 (2)

Access: Read/Write

Reset Value: 0x174

| | | | | | | | |
|-------------|----|----|----|----|-------------|----|----|
| 31 | 30 | 29 | 28 | 27 | 26 | 25 | 24 |
| – | – | – | – | – | – | – | – |
| 23 | 22 | 21 | 20 | 19 | 18 | 17 | 16 |
| – | – | – | – | – | – | – | – |
| 15 | 14 | 13 | 12 | 11 | 10 | 9 | 8 |
| – | – | – | – | – | FI_DI_RATIO | | |
| 7 | 6 | 5 | 4 | 3 | 2 | 1 | 0 |
| FI_DI_RATIO | | | | | | | |

- **FI_DI_RATIO: FI Over DI Ratio Value**

0: If ISO7816 mode is selected, the Baud Rate Generator generates no signal.

1–2047: If ISO7816 mode is selected, the Baud Rate is the clock provided on SCK divided by FI_DI_RATIO.

31.7.13 USART Number of Errors Register

Name: US_NER

Address: 0xFFFFB0044 (0), 0xFFFFB4044 (1), 0xFFFFB8044 (2)

Access: Read-only

| | | | | | | | |
|-----------|----|----|----|----|----|----|----|
| 31 | 30 | 29 | 28 | 27 | 26 | 25 | 24 |
| – | – | – | – | – | – | – | – |
| 23 | 22 | 21 | 20 | 19 | 18 | 17 | 16 |
| – | – | – | – | – | – | – | – |
| 15 | 14 | 13 | 12 | 11 | 10 | 9 | 8 |
| – | – | – | – | – | – | – | – |
| 7 | 6 | 5 | 4 | 3 | 2 | 1 | 0 |
| NB_ERRORS | | | | | | | |

- **NB_ERRORS: Number of Errors**

Total number of errors that occurred during an ISO7816 transfer. This register automatically clears when read.

31.7.14 USART IrDA FILTER Register

Name: US_IF

Address: 0xFFFFB004C (0), 0xFFFFB404C (1), 0xFFFFB804C (2)

Access: Read/Write

| | | | | | | | |
|-------------|----|----|----|----|----|----|----|
| 31 | 30 | 29 | 28 | 27 | 26 | 25 | 24 |
| – | – | – | – | – | – | – | – |
| 23 | 22 | 21 | 20 | 19 | 18 | 17 | 16 |
| – | – | – | – | – | – | – | – |
| 15 | 14 | 13 | 12 | 11 | 10 | 9 | 8 |
| – | – | – | – | – | – | – | – |
| 7 | 6 | 5 | 4 | 3 | 2 | 1 | 0 |
| IRDA_FILTER | | | | | | | |

- **IRDA_FILTER: IrDA Filter**

Sets the filter of the IrDA demodulator.

32. Synchronous Serial Controller (SSC)

32.1 Overview

The Atmel Synchronous Serial Controller (SSC) provides a synchronous communication link with external devices. It supports many serial synchronous communication protocols generally used in audio and telecom applications such as I2S, Short Frame Sync, Long Frame Sync, etc.

The SSC contains an independent receiver and transmitter and a common clock divider. The receiver and the transmitter each interface with three signals: the TD/RD signal for data, the TK/RK signal for the clock and the TF/RF signal for the Frame Sync. The transfers can be programmed to start automatically or on different events detected on the Frame Sync signal.

The SSC's high-level of programmability and its two dedicated PDC channels of up to 32 bits permit a continuous high bit rate data transfer without processor intervention.

Featuring connection to two PDC channels, the SSC permits interfacing with low processor overhead to the following:

- CODEC's in master or slave mode
- DAC through dedicated serial interface, particularly I2S
- Magnetic card reader

32.2 Block Diagram

Figure 32-1. Block Diagram

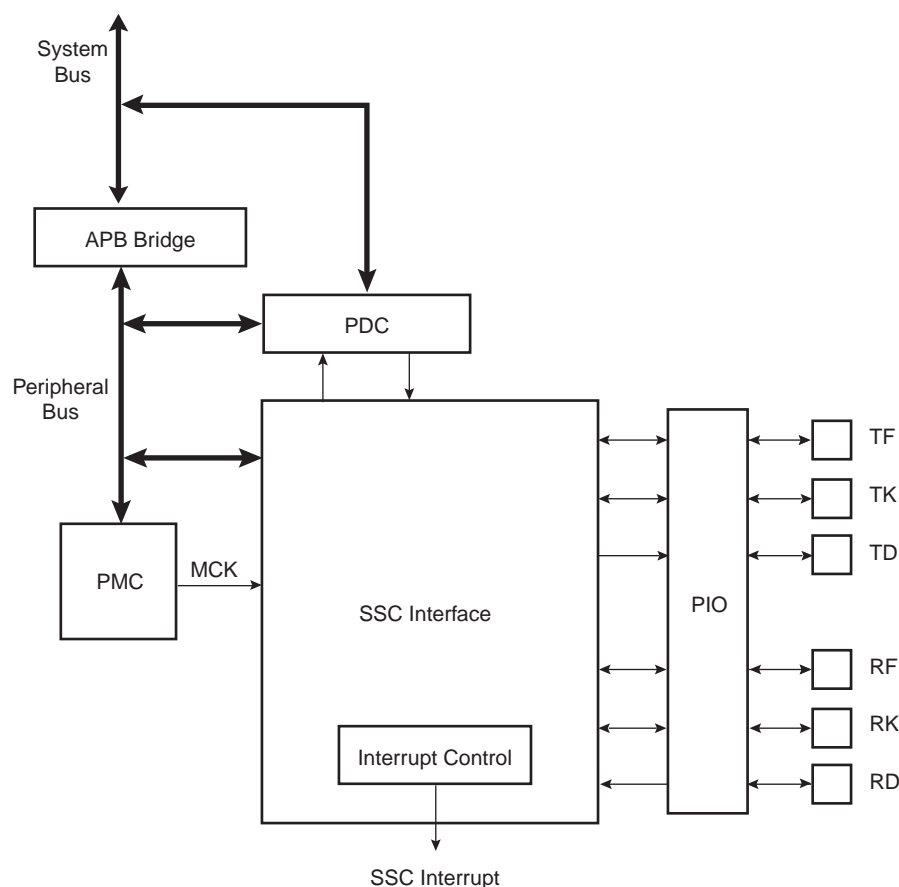

32.3 Application Block Diagram

Figure 32-2. Application Block Diagram

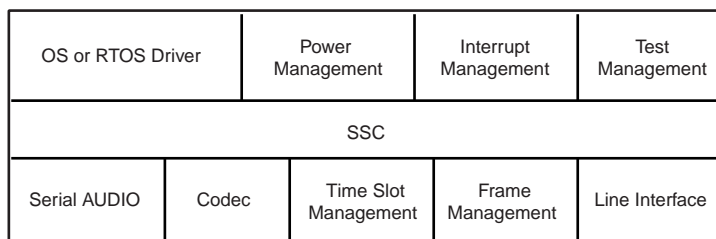

32.4 Pin Name List

Table 32-1. I/O Lines Description

| Pin Name | Pin Description | Type |
|----------|---------------------------|--------------|
| RF | Receiver Frame Synchro | Input/Output |
| RK | Receiver Clock | Input/Output |
| RD | Receiver Data | Input |
| TF | Transmitter Frame Synchro | Input/Output |
| TK | Transmitter Clock | Input/Output |
| TD | Transmitter Data | Output |

32.5 Product Dependencies

32.5.1 I/O Lines

The pins used for interfacing the compliant external devices may be multiplexed with PIO lines.

Before using the SSC receiver, the PIO controller must be configured to dedicate the SSC receiver I/O lines to the SSC peripheral mode.

Before using the SSC transmitter, the PIO controller must be configured to dedicate the SSC transmitter I/O lines to the SSC peripheral mode.

32.5.2 Power Management

The SSC is not continuously clocked. The SSC interface may be clocked through the Power Management Controller (PMC), therefore the programmer must first configure the PMC to enable the SSC clock.

32.5.3 Interrupt

The SSC interface has an interrupt line connected to the Advanced Interrupt Controller (AIC). Handling interrupts requires programming the AIC before configuring the SSC.

All SSC interrupts can be enabled/disabled configuring the SSC Interrupt mask register. Each pending and unmasked SSC interrupt will assert the SSC interrupt line. The SSC interrupt service routine can get the interrupt origin by reading the SSC interrupt status register.

32.6 Functional Description

This chapter contains the functional description of the following: SSC Functional Block, Clock Management, Data format, Start, Transmitter, Receiver and Frame Sync.

The receiver and transmitter operate separately. However, they can work synchronously by programming the receiver to use the transmit clock and/or to start a data transfer when transmission starts. Alternatively, this can be done by programming the transmitter to use the receive clock and/or to start a data transfer when reception starts. The transmitter and the receiver can be programmed to operate with the clock signals provided on either the TK or RK pins. This allows the SSC to support many slave-mode data transfers. The maximum clock speed allowed on the TK and RK pins is the master clock divided by 2.

Figure 32-3. SSC Functional Block Diagram

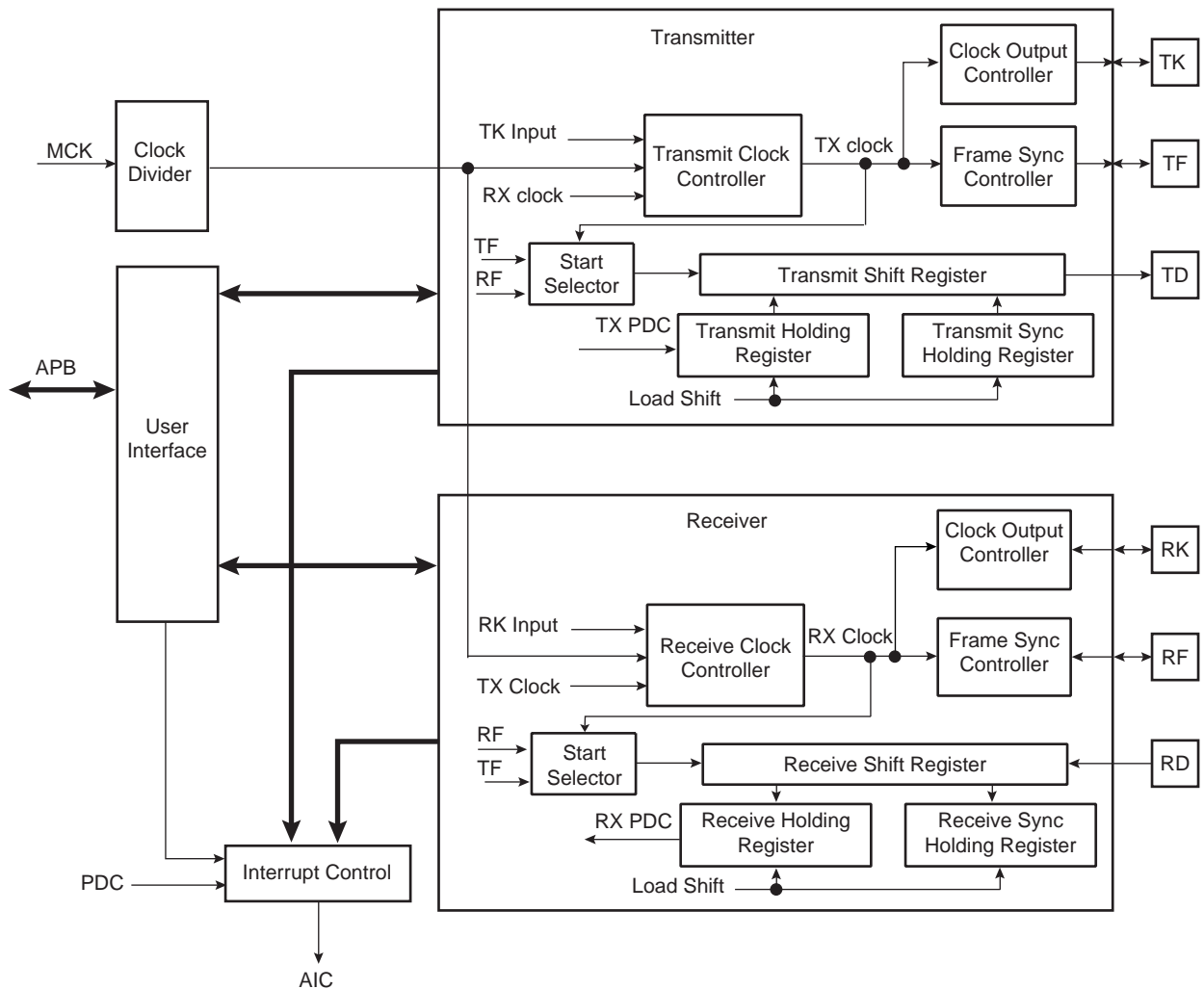

32.6.1 Clock Management

The transmitter clock can be generated by:

- an external clock received on the TK I/O pad
- the receiver clock
- the internal clock divider

The receiver clock can be generated by:

- an external clock received on the RK I/O pad
- the transmitter clock
- the internal clock divider

Furthermore, the transmitter block can generate an external clock on the TK I/O pad, and the receiver block can generate an external clock on the RK I/O pad.

This allows the SSC to support many Master and Slave Mode data transfers.

32.6.1.1 Clock Divider

Figure 32-4. Divided Clock Block Diagram

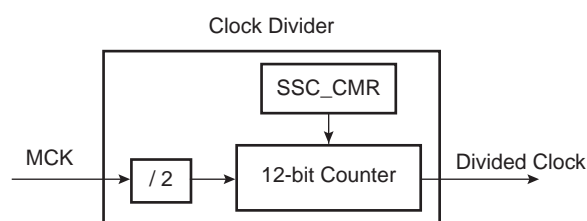

The Master Clock divider is determined by the 12-bit field DIV counter and comparator (so its maximal value is 4095) in the Clock Mode Register SSC_CMCR, allowing a Master Clock division by up to 8190. The Divided Clock is provided to both the Receiver and Transmitter. When this field is programmed to 0, the Clock Divider is not used and remains inactive.

When DIV is set to a value equal to or greater than 1, the Divided Clock has a frequency of Master Clock divided by 2 times DIV. Each level of the Divided Clock has a duration of the Master Clock multiplied by DIV. This ensures a 50% duty cycle for the Divided Clock regardless of whether the DIV value is even or odd.

Figure 32-5. Divided Clock Generation

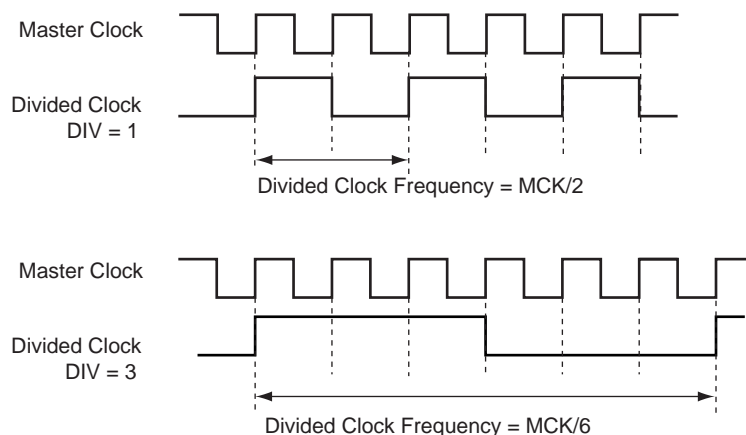

32.6.1.2 Transmitter Clock Management

The transmitter clock is generated from the receiver clock or the divider clock or an external clock scanned on the TK I/O pad. The transmitter clock is selected by the CKS field in SSC_TCMR (Transmit Clock Mode Register). Transmit Clock can be inverted independently by the CKI bits in SSC_TCMR.

The transmitter can also drive the TK I/O pad continuously or be limited to the actual data transfer. The clock output is configured by the SSC_TCMR. The Transmit Clock Inversion (CKI) bits have no effect on the clock outputs. Programming the TCMR to select TK pin (CKS field) and at the same time Continuous Transmit Clock (CKO field) might lead to unpredictable results.

Figure 32-6. Transmitter Clock Management

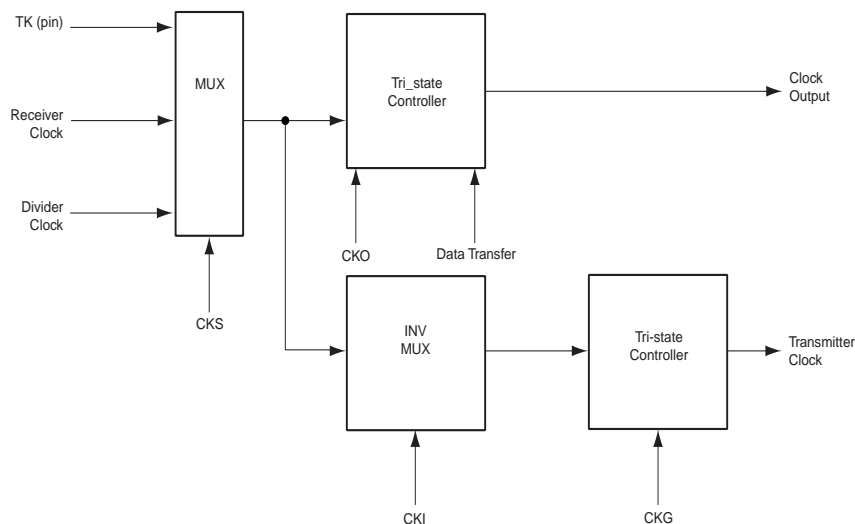

32.6.1.3 Receiver Clock Management

The receiver clock is generated from the transmitter clock or the divider clock or an external clock scanned on the RK I/O pad. The Receive Clock is selected by the CKS field in SSC_RCMR (Receive Clock Mode Register). Receive Clocks can be inverted independently by the CKI bits in SSC_RCMR.

The receiver can also drive the RK I/O pad continuously or be limited to the actual data transfer. The clock output is configured by the SSC_RCMR. The Receive Clock Inversion (CKI) bits have no effect on the clock outputs. Programming the RCMR to select RK pin (CKS field) and at the same time Continuous Receive Clock (CKO field) can lead to unpredictable results.

Figure 32-7. Receiver Clock Management

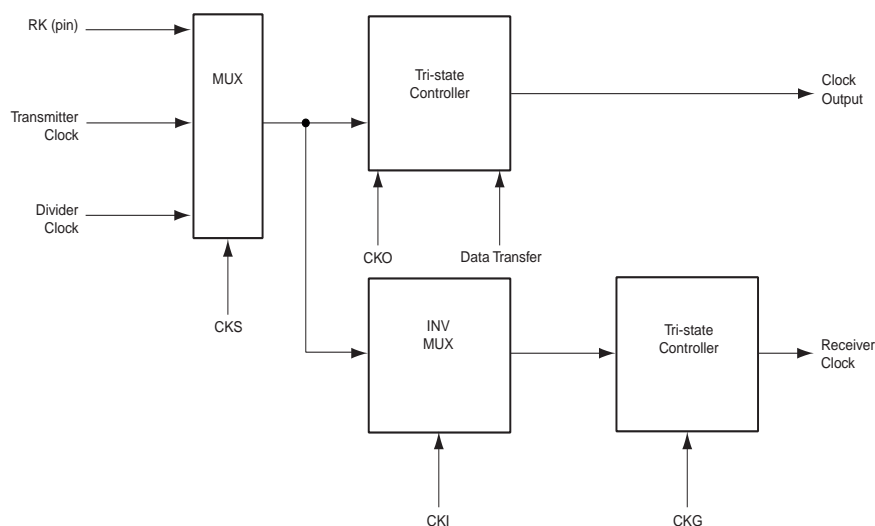

32.6.1.4 Serial Clock Ratio Considerations

The Transmitter and the Receiver can be programmed to operate with the clock signals provided on either the TK or RK pins. This allows the SSC to support many slave-mode data transfers. In this case, the maximum clock speed allowed on the RK pin is:

- Master Clock divided by 2 if Receiver Frame Synchro is input
- Master Clock divided by 3 if Receiver Frame Synchro is output

In addition, the maximum clock speed allowed on the TK pin is:

- Master Clock divided by 6 if Transmit Frame Synchro is input
- Master Clock divided by 2 if Transmit Frame Synchro is output

32.6.2 Transmitter Operations

A transmitted frame is triggered by a start event and can be followed by synchronization data before data transmission.

The start event is configured by setting the Transmit Clock Mode Register (SSC_TCMR). See “Start” on page 482. The frame synchronization is configured setting the Transmit Frame Mode Register (SSC_TFMR). See “Frame Sync” on page 484.

To transmit data, the transmitter uses a shift register clocked by the transmitter clock signal and the start mode selected in the SSC_TCMR. Data is written by the application to the SSC_THR then transferred to the shift register according to the data format selected.

When both the SSC_THR and the transmit shift register are empty, the status flag TXEMPTY is set in SSC_SR. When the Transmit Holding register is transferred in the Transmit shift register, the status flag TXRDY is set in SSC_SR and additional data can be loaded in the holding register.

Figure 32-8. Transmitter Block Diagram

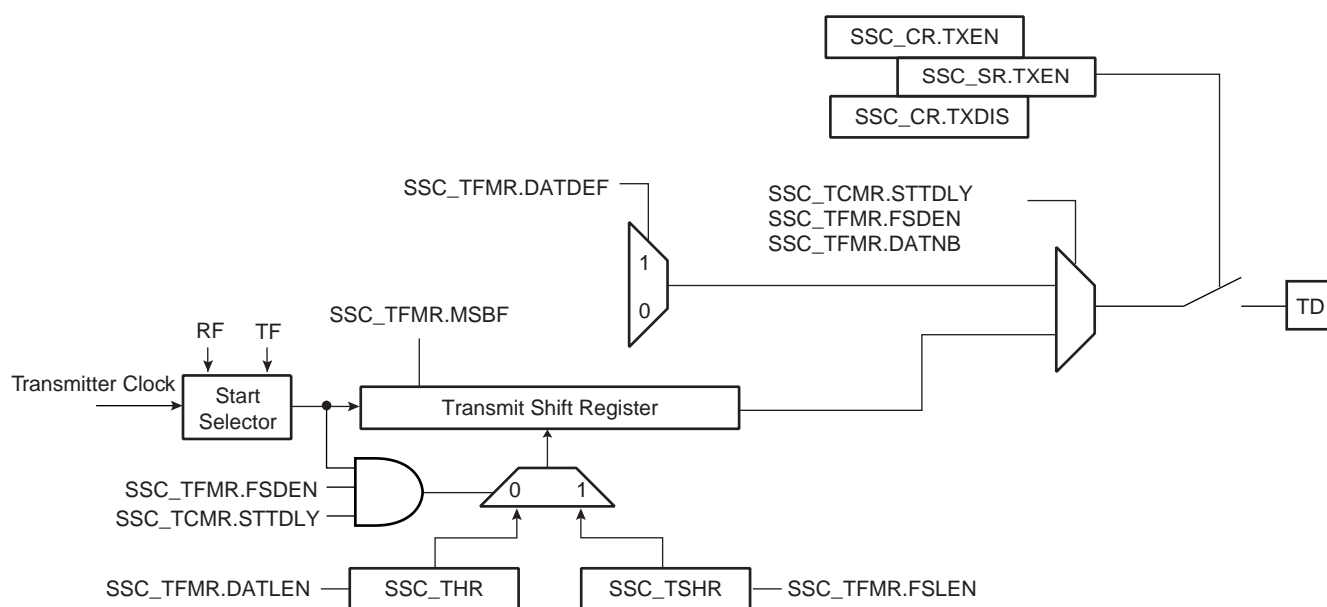

32.6.3 Receiver Operations

A received frame is triggered by a start event and can be followed by synchronization data before data transmission.

The start event is configured setting the Receive Clock Mode Register (SSC_RCMR). See “Start” on page 482.

The frame synchronization is configured setting the Receive Frame Mode Register (SSC_RFMR). See “Frame Sync” on page 484.

The receiver uses a shift register clocked by the receiver clock signal and the start mode selected in the SSC_RCMR. The data is transferred from the shift register depending on the data format selected.

When the receiver shift register is full, the SSC transfers this data in the holding register, the status flag RXRDY is set in SSC_SR and the data can be read in the receiver holding register. If another transfer occurs before read of the RHR, the status flag OVERUN is set in SSC_SR and the receiver shift register is transferred in the RHR.

Figure 32-9. Receiver Block Diagram

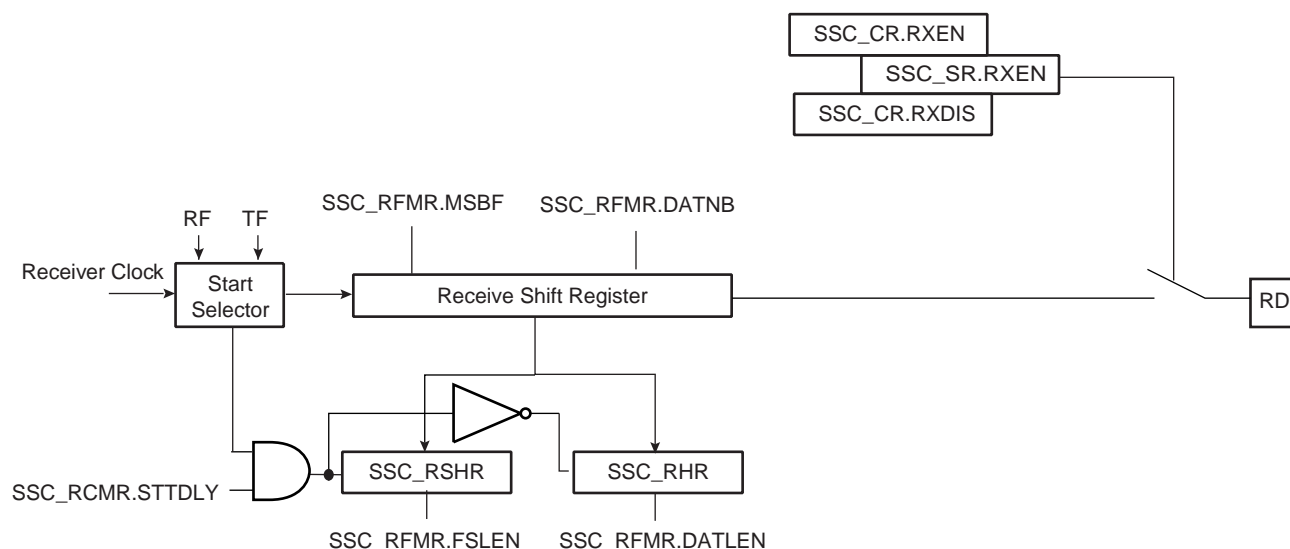

32.6.4 Start

The transmitter and receiver can both be programmed to start their operations when an event occurs, respectively in the Transmit Start Selection (START) field of SSC_TCMR and in the Receive Start Selection (START) field of SSC_RCMR.

Under the following conditions the start event is independently programmable:

- Continuous. In this case, the transmission starts as soon as a word is written in SSC_THR and the reception starts as soon as the Receiver is enabled.
- Synchronously with the transmitter/receiver
- On detection of a falling/rising edge on TF/RF
- On detection of a low level/high level on TF/RF
- On detection of a level change or an edge on TF/RF

A start can be programmed in the same manner on either side of the Transmit/Receive Clock Register (RCMR/TCMR). Thus, the start could be on TF (Transmit) or RF (Receive).

Moreover, the Receiver can start when data is detected in the bit stream with the Compare Functions.

Detection on TF/RF input/output is done by the field FSOS of the Transmit/Receive Frame Mode Register (TFMR/RFMR).

Figure 32-10. Transmit Start Mode

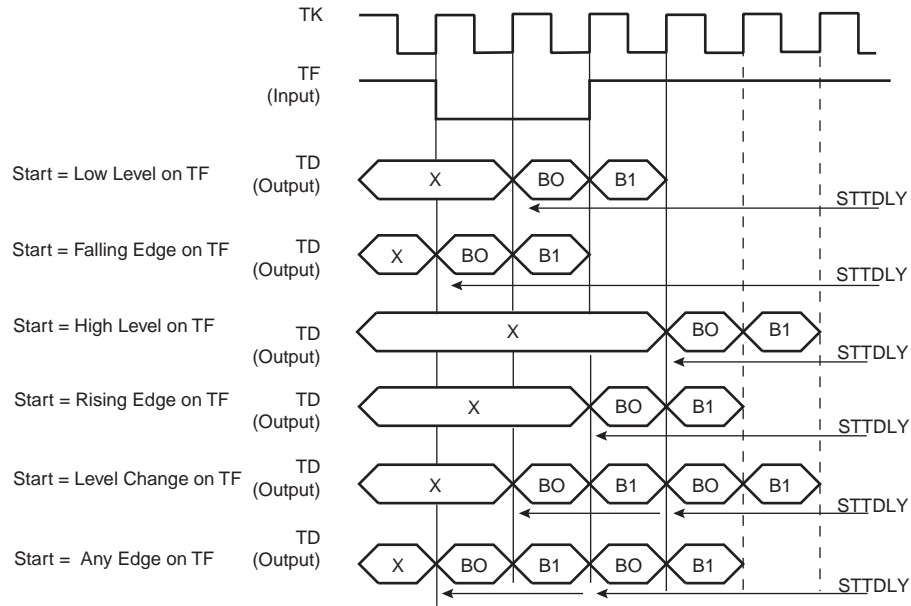
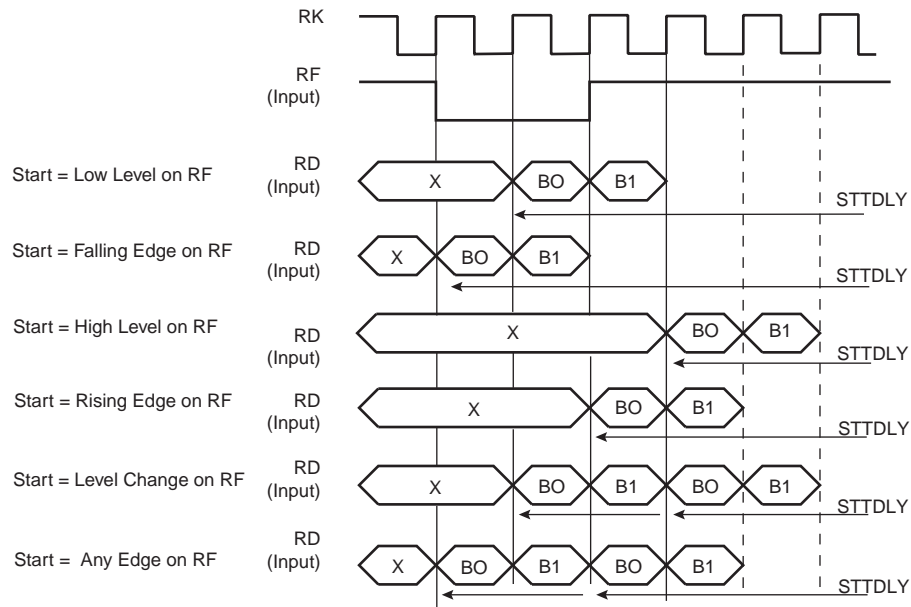

Figure 32-11. Receive Pulse/Edge Start Modes



32.6.5 Frame Sync

The Transmitter and Receiver Frame Sync pins, TF and RF, can be programmed to generate different kinds of frame synchronization signals. The Frame Sync Output Selection (FSOS) field in the Receive Frame Mode Register (SSC_RFMR) and in the Transmit Frame Mode Register (SSC_TFMR) are used to select the required waveform.

- Programmable low or high levels during data transfer are supported.
- Programmable high levels before the start of data transfers or toggling are also supported.

If a pulse waveform is selected, the Frame Sync Length (FSLEN) field in SSC_RFMR and SSC_TFMR programs the length of the pulse, from 1 bit time up to 16 bit time.

The periodicity of the Receive and Transmit Frame Sync pulse output can be programmed through the Period Divider Selection (PERIOD) field in SSC_RCMR and SSC_TCMR.

32.6.5.1 Frame Sync Data

Frame Sync Data transmits or receives a specific tag during the Frame Sync signal.

During the Frame Sync signal, the Receiver can sample the RD line and store the data in the Receive Sync Holding Register and the transmitter can transfer Transmit Sync Holding Register in the Shifter Register. The data length to be sampled/shifted out during the Frame Sync signal is programmed by the FSLEN field in SSC_RFMR/SSC_TFMR and has a maximum value of 16.

Concerning the Receive Frame Sync Data operation, if the Frame Sync Length is equal to or lower than the delay between the start event and the actual data reception, the data sampling operation is performed in the Receive Sync Holding Register through the Receive Shift Register.

The Transmit Frame Sync Operation is performed by the transmitter only if the bit Frame Sync Data Enable (FSDEN) in SSC_TFMR is set. If the Frame Sync length is equal to or lower than the delay between the start event and the actual data transmission, the normal transmission has priority and the data contained in the Transmit Sync Holding Register is transferred in the Transmit Register, then shifted out.

32.6.5.2 Frame Sync Edge Detection

The Frame Sync Edge detection is programmed by the FSEDGE field in SSC_RFMR/SSC_TFMR. This sets the corresponding flags RXSYN/TXSYN in the SSC Status Register (SSC_SR) on frame synchro edge detection (signals RF/TF).

32.6.6 Receive Compare Modes

Figure 32-12. Receive Compare Modes

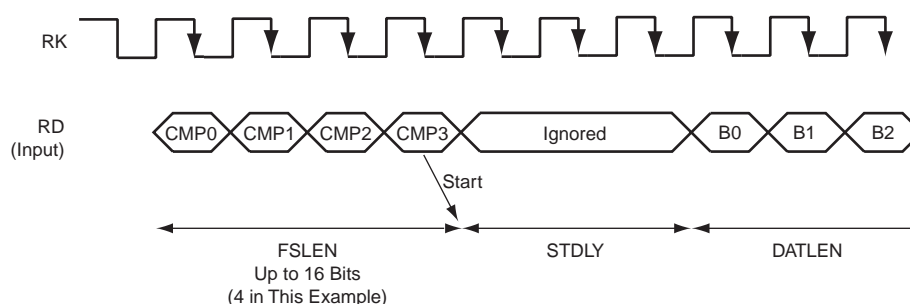

32.6.6.1 Compare Functions

Length of the comparison patterns (Compare 0, Compare 1) and thus the number of bits they are compared to is defined by FSLEN, but with a maximum value of 16 bits. Comparison is always done by comparing the last bits received with the comparison pattern. Compare 0 can be one start event of the Receiver. In this case, the receiver compares at each new sample the last bits received at the Compare 0 pattern contained in the Compare 0 Register (SSC_RC0R). When this start event is selected, the user can program the Receiver to start a new data transfer either by writing a new Compare 0, or by receiving continuously until Compare 1 occurs. This selection is done with the bit (STOP) in SSC_RCMR.

32.6.7 Data Format

The data framing format of both the transmitter and the receiver are programmable through the Transmitter Frame Mode Register (SSC_TFMR) and the Receiver Frame Mode Register (SSC_RFMR). In either case, the user can independently select:

- the event that starts the data transfer (START)
- the delay in number of bit periods between the start event and the first data bit (STTDLY)
- the length of the data (DATLEN)
- the number of data to be transferred for each start event (DATNB).
- the length of synchronization transferred for each start event (FSLEN)
- the bit sense: most or lowest significant bit first (MSBF)

Additionally, the transmitter can be used to transfer synchronization and select the level driven on the TD pin while not in data transfer operation. This is done respectively by the Frame Sync Data Enable (FSDEN) and by the Data Default Value (DATDEF) bits in SSC_TFMR.

Table 32-2. Data Frame Registers

| Transmitter | Receiver | Field | Length | Comment |
|-------------|----------|--------|-----------|--------------------------------------|
| SSC_TFMR | SSC_RFMR | DATLEN | Up to 32 | Size of word |
| SSC_TFMR | SSC_RFMR | DATNB | Up to 16 | Number of words transmitted in frame |
| SSC_TFMR | SSC_RFMR | MSBF | | Most significant bit first |
| SSC_TFMR | SSC_RFMR | FSLEN | Up to 16 | Size of Synchro data register |
| SSC_TFMR | | DATDEF | 0 or 1 | Data default value ended |
| SSC_TFMR | | FSDEN | | Enable send SSC_TSHR |
| SSC_TCMR | SSC_RCMR | PERIOD | Up to 512 | Frame size |
| SSC_TCMR | SSC_RCMR | STTDLY | Up to 255 | Size of transmit start delay |

Figure 32-13. Transmit and Receive Frame Format in Edge/Pulse Start Modes

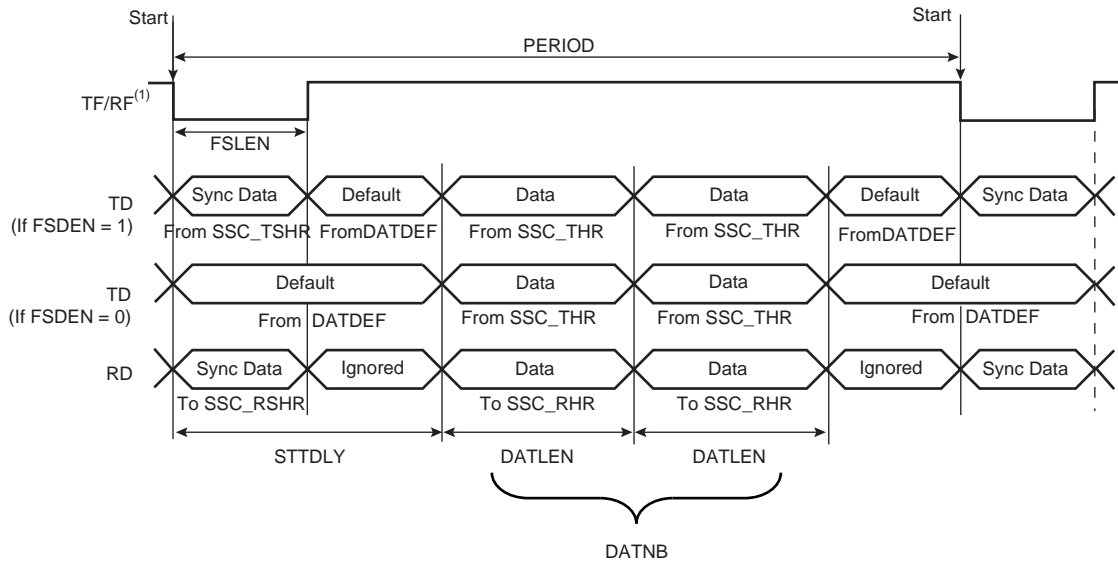

Note: 1. Example of input on falling edge of TF/RF.

Figure 32-14. Transmit Frame Format in Continuous Mode

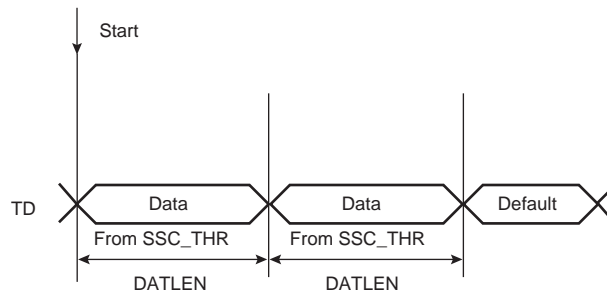

Start: 1. TXEMPTY set to 1
2. Write into the SSC_THR

Note: 1. STTDLY is set to 0. In this example, SSC_THR is loaded twice. FSDEN value has no effect on the transmission. SyncData cannot be output in continuous mode.

Figure 32-15. Receive Frame Format in Continuous Mode

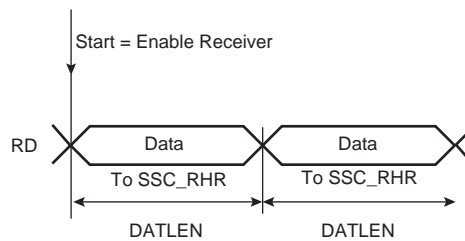

Note: 1. STTDLY is set to 0.

32.6.8 Loop Mode

The receiver can be programmed to receive transmissions from the transmitter. This is done by setting the Loop Mode (LOOP) bit in SSC_RFMR. In this case, RD is connected to TD, RF is connected to TF and RK is connected to TK.

32.6.9 Interrupt

Most bits in SSC_SR have a corresponding bit in interrupt management registers.

The SSC can be programmed to generate an interrupt when it detects an event. The interrupt is controlled by writing SSC_IER (Interrupt Enable Register) and SSC_IDR (Interrupt Disable Register). These registers enable and disable, respectively, the corresponding interrupt by setting and clearing the corresponding bit in SSC_IMR (Interrupt Mask Register), which controls the generation of interrupts by asserting the SSC interrupt line connected to the AIC.

Figure 32-16. Interrupt Block Diagram

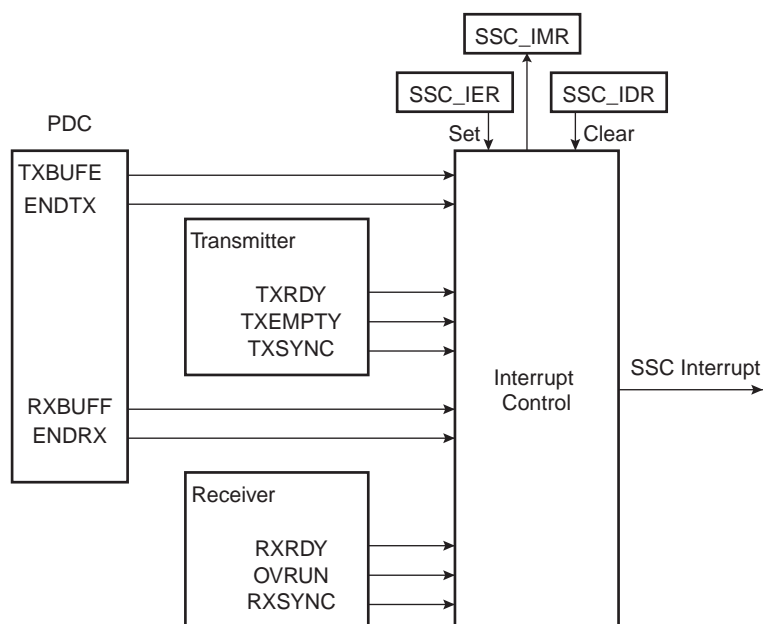

32.7 SSC Application Examples

The SSC can support several serial communication modes used in audio or high speed serial links. Some standard applications are shown in the following figures. All serial link applications supported by the SSC are not listed here.

Figure 32-17. Audio Application Block Diagram

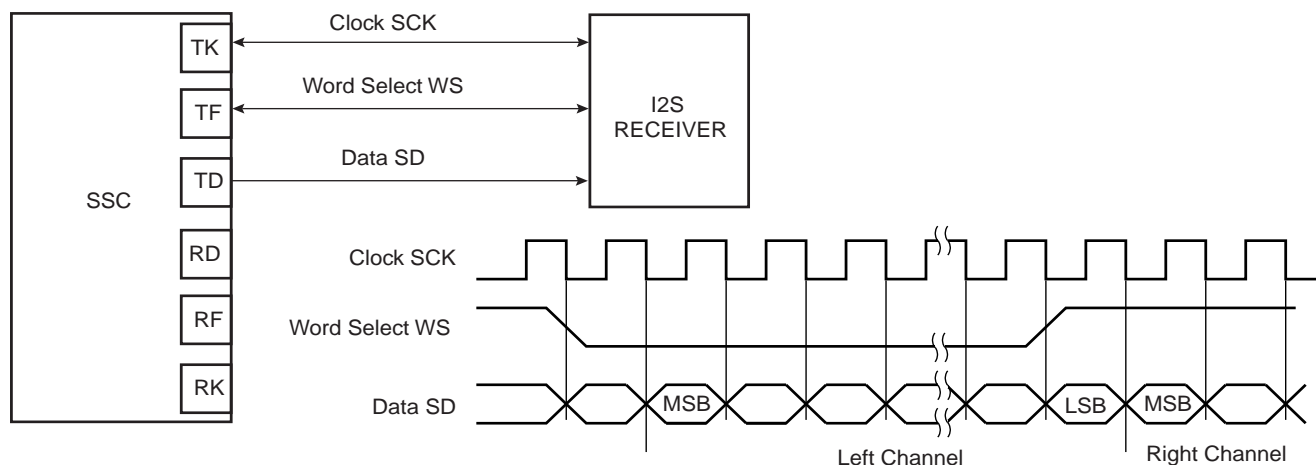

Figure 32-18. Codec Application Block Diagram

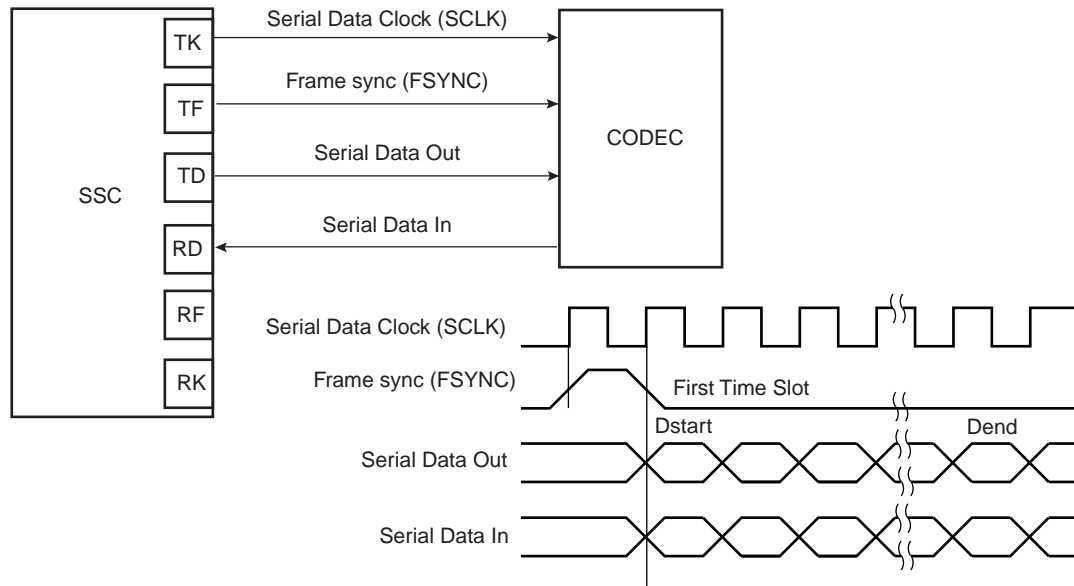
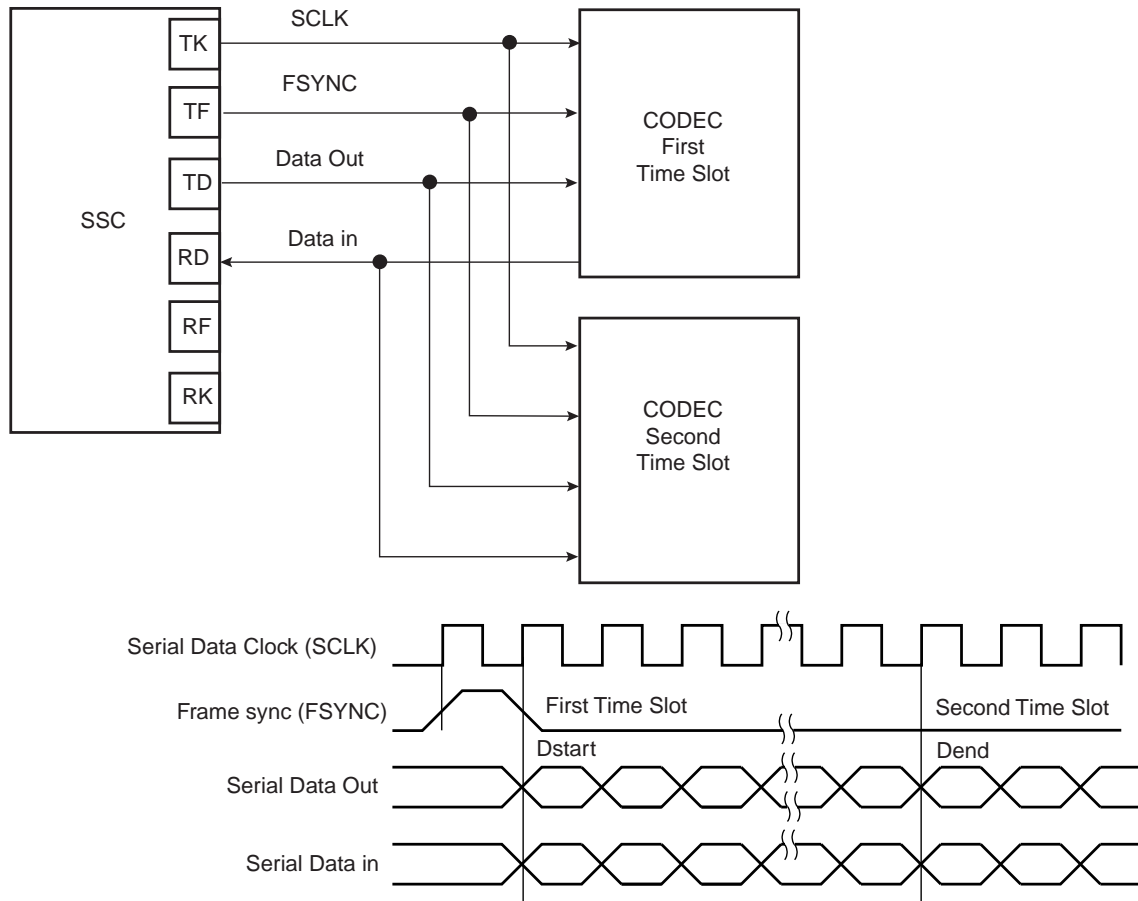

Figure 32-19. Time Slot Application Block Diagram



32.8 Synchronous Serial Controller (SSC) User Interface

Table 32-3. Register Mapping

| Offset | Register | Name | Access | Reset |
|-------------|---|----------|------------|------------|
| 0x0 | Control Register | SSC_CR | Write-only | – |
| 0x4 | Clock Mode Register | SSC_CMR | Read/Write | 0x0 |
| 0x8 | Reserved | – | – | – |
| 0xC | Reserved | – | – | – |
| 0x10 | Receive Clock Mode Register | SSC_RCMR | Read/Write | 0x0 |
| 0x14 | Receive Frame Mode Register | SSC_RFMR | Read/Write | 0x0 |
| 0x18 | Transmit Clock Mode Register | SSC_TCMR | Read/Write | 0x0 |
| 0x1C | Transmit Frame Mode Register | SSC_TFMR | Read/Write | 0x0 |
| 0x20 | Receive Holding Register | SSC_RHR | Read-only | 0x0 |
| 0x24 | Transmit Holding Register | SSC_THR | Write-only | – |
| 0x28 | Reserved | – | – | – |
| 0x2C | Reserved | – | – | – |
| 0x30 | Receive Sync. Holding Register | SSC_RSHR | Read-only | 0x0 |
| 0x34 | Transmit Sync. Holding Register | SSC_TSHR | Read/Write | 0x0 |
| 0x38 | Receive Compare 0 Register | SSC_RC0R | Read/Write | 0x0 |
| 0x3C | Receive Compare 1 Register | SSC_RC1R | Read/Write | 0x0 |
| 0x40 | Status Register | SSC_SR | Read-only | 0x000000CC |
| 0x44 | Interrupt Enable Register | SSC_IER | Write-only | – |
| 0x48 | Interrupt Disable Register | SSC_IDR | Write-only | – |
| 0x4C | Interrupt Mask Register | SSC_IMR | Read-only | 0x0 |
| 0x50–0xFC | Reserved | – | – | – |
| 0x100–0x124 | Reserved for Peripheral Data Controller (PDC) | – | – | – |

32.8.1 SSC Control Register

Name: SSC_CR

Address: 0xFFFFBC000 (0), 0xFFFFC0000 (1), 0xFFFFC4000 (2)

Access: Write-only

| | | | | | | | |
|-------|----|----|----|----|----|-------|------|
| 31 | 30 | 29 | 28 | 27 | 26 | 25 | 24 |
| – | – | – | – | – | – | – | – |
| 23 | 22 | 21 | 20 | 19 | 18 | 17 | 16 |
| – | – | – | – | – | – | – | – |
| 15 | 14 | 13 | 12 | 11 | 10 | 9 | 8 |
| SWRST | – | – | – | – | – | TXDIS | TXEN |
| 7 | 6 | 5 | 4 | 3 | 2 | 1 | 0 |
| – | – | – | – | – | – | RXDIS | RXEN |

- **RXEN: Receive Enable**

0: No effect.

1: Enables Receive if RXDIS is not set.

- **RXDIS: Receive Disable**

0: No effect.

1: Disables Receive. If a character is currently being received, disables at end of current character reception.

- **TXEN: Transmit Enable**

0: No effect.

1: Enables Transmit if TXDIS is not set.

- **TXDIS: Transmit Disable**

0: No effect.

1: Disables Transmit. If a character is currently being transmitted, disables at end of current character transmission.

- **SWRST: Software Reset**

0: No effect.

1: Performs a software reset. Has priority on any other bit in SSC_CR.

32.8.2 SSC Clock Mode Register

Name: SSC_CMR

Address: 0xFFFFBC004 (0), 0xFFFFC0004 (1), 0xFFFFC4004 (2)

Access: Read/Write

| | | | | | | | |
|-----|----|----|----|-----|----|----|----|
| 31 | 30 | 29 | 28 | 27 | 26 | 25 | 24 |
| – | – | – | – | – | – | – | – |
| 23 | 22 | 21 | 20 | 19 | 18 | 17 | 16 |
| – | – | – | – | – | – | – | – |
| 15 | 14 | 13 | 12 | 11 | 10 | 9 | 8 |
| – | – | – | – | DIV | | | |
| 7 | 6 | 5 | 4 | 3 | 2 | 1 | 0 |
| DIV | | | | | | | |

- **DIV: Clock Divider**

0: The Clock Divider is not active.

Any Other Value: The Divided Clock equals the Master Clock divided by 2 times DIV. The maximum bit rate is $MCK/2$. The minimum bit rate is $MCK/2 \times 4095 = MCK/8190$.

32.8.3 SSC Receive Clock Mode Register

Name: SSC_RCMR

Address: 0xFFFFBC010 (0), 0xFFFFC0010 (1), 0xFFFFC4010 (2)

Access: Read/Write

| | | | | | | | |
|--------|----|-----|------|-------|----|-----|----|
| 31 | 30 | 29 | 28 | 27 | 26 | 25 | 24 |
| PERIOD | | | | | | | |
| 23 | 22 | 21 | 20 | 19 | 18 | 17 | 16 |
| STTDLY | | | | | | | |
| 15 | 14 | 13 | 12 | 11 | 10 | 9 | 8 |
| - | - | - | STOP | START | | | |
| 7 | 6 | 5 | 4 | 3 | 2 | 1 | 0 |
| CKG | | CKI | CKO | | | CKS | |

• CKS: Receive Clock Selection

| Value | Selected Receive Clock |
|-------|------------------------|
| 0x0 | Divided Clock |
| 0x1 | TK Clock signal |
| 0x2 | RK pin |
| 0x3 | Reserved |

• CKO: Receive Clock Output Mode Selection

| Value | Receive Clock Output Mode | RK pin |
|---------|--|------------|
| 0x0 | None | Input-only |
| 0x1 | Continuous Receive Clock | Output |
| 0x2 | Receive Clock only during data transfers | Output |
| 0x3–0x7 | Reserved | |

• CKI: Receive Clock Inversion

0: The data inputs (Data and Frame Sync signals) are sampled on Receive Clock falling edge. The Frame Sync signal output is shifted out on Receive Clock rising edge.

1: The data inputs (Data and Frame Sync signals) are sampled on Receive Clock rising edge. The Frame Sync signal output is shifted out on Receive Clock falling edge.

CKI affects only the Receive Clock and not the output clock signal.

• CKG: Receive Clock Gating Selection

| Value | Receive Clock Gating |
|-------|---------------------------------------|
| 0x0 | None, continuous clock |
| 0x1 | Receive Clock enabled only if RF Low |
| 0x2 | Receive Clock enabled only if RF High |
| 0x3 | Reserved |

- **START: Receive Start Selection**

| Value | Receive Start |
|---------|---|
| 0x0 | Continuous, as soon as the receiver is enabled, and immediately after the end of transfer of the previous data. |
| 0x1 | Transmit start |
| 0x2 | Detection of a low level on RF signal |
| 0x3 | Detection of a high level on RF signal |
| 0x4 | Detection of a falling edge on RF signal |
| 0x5 | Detection of a rising edge on RF signal |
| 0x6 | Detection of any level change on RF signal |
| 0x7 | Detection of any edge on RF signal |
| 0x8 | Compare 0 |
| 0x9–0xF | Reserved |

- **STOP: Receive Stop Selection**

0: After completion of a data transfer when starting with a Compare 0, the receiver stops the data transfer and waits for a new compare 0.

1: After starting a receive with a Compare 0, the receiver operates in a continuous mode until a Compare 1 is detected.

- **STTDLY: Receive Start Delay**

If STTDLY is not 0, a delay of STTDLY clock cycles is inserted between the start event and the actual start of reception. When the Receiver is programmed to start synchronously with the Transmitter, the delay is also applied.

Note: It is very important that STTDLY be set carefully. If STTDLY must be set, it should be done in relation to TAG (Receive Sync Data) reception.

- **PERIOD: Receive Period Divider Selection**

This field selects the divider to apply to the selected Receive Clock in order to generate a new Frame Sync Signal. If 0, no PERIOD signal is generated. If not 0, a PERIOD signal is generated each $2 \times (\text{PERIOD} + 1)$ Receive Clock.

32.8.4 SSC Receive Frame Mode Register

Name: SSC_RFMR

Address: 0xFFFFBC014 (0), 0xFFFFC0014 (1), 0xFFFFC4014 (2)

Access: Read/Write

| | | | | | | | |
|------|------|------|--------|-------|----|----|--------|
| 31 | 30 | 29 | 28 | 27 | 26 | 25 | 24 |
| – | – | – | – | – | – | – | FSEDGE |
| 23 | 22 | 21 | 20 | 19 | 18 | 17 | 16 |
| – | FSOS | | | FSLEN | | | |
| 15 | 14 | 13 | 12 | 11 | 10 | 9 | 8 |
| – | – | – | – | DATNB | | | |
| 7 | 6 | 5 | 4 | 3 | 2 | 1 | 0 |
| MSBF | – | LOOP | DATLEN | | | | |

- **DATLEN: Data Length**

0: Forbidden value (1-bit data length not supported).

Any other value: The bit stream contains DATLEN + 1 data bits. Moreover, it defines the transfer size performed by the PDC2 assigned to the Receiver. If DATLEN is lower or equal to 7, data transfers are in bytes. If DATLEN is between 8 and 15 (included), half-words are transferred, and for any other value, 32-bit words are transferred.

- **LOOP: Loop Mode**

0: Normal operating mode.

1: RD is driven by TD, RF is driven by TF and TK drives RK.

- **MSBF: Most Significant Bit First**

0: The lowest significant bit of the data register is sampled first in the bit stream.

1: The most significant bit of the data register is sampled first in the bit stream.

- **DATNB: Data Number per Frame**

This field defines the number of data words to be received after each transfer start, which is equal to (DATNB + 1).

- **FSLEN: Receive Frame Sync Length**

This field defines the number of bits sampled and stored in the Receive Sync Data Register. When this mode is selected by the START field in the Receive Clock Mode Register, it also determines the length of the sampled data to be compared to the Compare 0 or Compare 1 register.

- **FSOS: Receive Frame Sync Output Selection**

| Value | Selected Receive Frame Sync Signal | RF Pin |
|---------|---|------------|
| 0x0 | None | Input-only |
| 0x1 | Negative Pulse | Output |
| 0x2 | Positive Pulse | Output |
| 0x3 | Driven Low during data transfer | Output |
| 0x4 | Driven High during data transfer | Output |
| 0x5 | Toggling at each start of data transfer | Output |
| 0x6–0x7 | Reserved | Undefined |

- **FSEGE: Frame Sync Edge Detection**

Determines which edge on Frame Sync will generate the interrupt RXSYN in the SSC Status Register.

| Value | Frame Sync Edge Detection |
|-------|---------------------------|
| 0x0 | Positive Edge Detection |
| 0x1 | Negative Edge Detection |

32.8.5 SSC Transmit Clock Mode Register

Name: SSC_TCMR

Address: 0xFFFFBC018 (0), 0xFFFFC0018 (1), 0xFFFFC4018 (2)

Access: Read/Write

| | | | | | | | |
|--------|----|-----|-----|-------|----|-----|----|
| 31 | 30 | 29 | 28 | 27 | 26 | 25 | 24 |
| PERIOD | | | | | | | |
| 23 | 22 | 21 | 20 | 19 | 18 | 17 | 16 |
| STTDLY | | | | | | | |
| 15 | 14 | 13 | 12 | 11 | 10 | 9 | 8 |
| - | - | - | - | START | | | |
| 7 | 6 | 5 | 4 | 3 | 2 | 1 | 0 |
| CKG | | CKI | CKO | | | CKS | |

• CKS: Transmit Clock Selection

| Value | Selected Transmit Clock |
|-------|-------------------------|
| 0x0 | Divided Clock |
| 0x1 | RK Clock signal |
| 0x2 | TK Pin |
| 0x3 | Reserved |

• CKO: Transmit Clock Output Mode Selection

| Value | Transmit Clock Output Mode | TK pin |
|---------|---|------------|
| 0x0 | None | Input-only |
| 0x1 | Continuous Transmit Clock | Output |
| 0x2 | Transmit Clock only during data transfers | Output |
| 0x3–0x7 | Reserved | |

• CKI: Transmit Clock Inversion

0: The data outputs (Data and Frame Sync signals) are shifted out on Transmit Clock falling edge. The Frame sync signal input is sampled on Transmit clock rising edge.

1: The data outputs (Data and Frame Sync signals) are shifted out on Transmit Clock rising edge. The Frame sync signal input is sampled on Transmit clock falling edge.

CKI affects only the Transmit Clock and not the output clock signal.

• CKG: Transmit Clock Gating Selection

| Value | Transmit Clock Gating |
|-------|--|
| 0x0 | None, continuous clock |
| 0x1 | Transmit Clock enabled only if TF Low |
| 0x2 | Transmit Clock enabled only if TF High |
| 0x3 | Reserved |

- **START: Transmit Start Selection**

| Value | Transmit Start |
|---------|--|
| 0x0 | Continuous, as soon as a word is written in the SSC_THR Register (if Transmit is enabled), and immediately after the end of transfer of the previous data. |
| 0x1 | Receive start |
| 0x2 | Detection of a low level on TF signal |
| 0x3 | Detection of a high level on TF signal |
| 0x4 | Detection of a falling edge on TF signal |
| 0x5 | Detection of a rising edge on TF signal |
| 0x6 | Detection of any level change on TF signal |
| 0x7 | Detection of any edge on TF signal |
| 0x8–0xF | Reserved |

- **STTDLY: Transmit Start Delay**

If STTDLY is not 0, a delay of STTDLY clock cycles is inserted between the start event and the actual start of transmission of data. When the Transmitter is programmed to start synchronously with the Receiver, the delay is also applied.

Note: STTDLY must be set carefully. If STTDLY is too short in respect to TAG (Transmit Sync Data) emission, data is emitted instead of the end of TAG.

- **PERIOD: Transmit Period Divider Selection**

This field selects the divider to apply to the selected Transmit Clock to generate a new Frame Sync Signal. If 0, no period signal is generated. If not 0, a period signal is generated at each $2 \times (\text{PERIOD} + 1)$ Transmit Clock.

32.8.6 SSC Transmit Frame Mode Register

Name: SSC_TFMR

Address: 0xFFFFBC01C (0), 0xFFFFC001C (1), 0xFFFFC401C (2)

Access: Read/Write

| | | | | | | | |
|-------|------|--------|--------|-------|----|----|--------|
| 31 | 30 | 29 | 28 | 27 | 26 | 25 | 24 |
| – | – | – | – | – | – | – | FSEDGE |
| 23 | 22 | 21 | 20 | 19 | 18 | 17 | 16 |
| FSDEN | FSOS | | | FSLEN | | | |
| 15 | 14 | 13 | 12 | 11 | 10 | 9 | 8 |
| – | – | – | – | DATNB | | | |
| 7 | 6 | 5 | 4 | 3 | 2 | 1 | 0 |
| MSBF | – | DATDEF | DATLEN | | | | |

- **DATLEN: Data Length**

0: Forbidden value (1-bit data length not supported).

Any other value: The bit stream contains DATLEN + 1 data bits. Moreover, it defines the transfer size performed by the PDC2 assigned to the Transmit. If DATLEN is lower or equal to 7, data transfers are bytes, if DATLEN is between 8 and 15 (included), half-words are transferred, and for any other value, 32-bit words are transferred.

- **DATDEF: Data Default Value**

This bit defines the level driven on the TD pin while out of transmission. Note that if the pin is defined as multi-drive by the PIO Controller, the pin is enabled only if the SCC TD output is 1.

- **MSBF: Most Significant Bit First**

0: The lowest significant bit of the data register is shifted out first in the bit stream.

1: The most significant bit of the data register is shifted out first in the bit stream.

- **DATNB: Data Number per frame**

This field defines the number of data words to be transferred after each transfer start, which is equal to (DATNB + 1).

- **FSLEN: Transmit Frame Syn Length**

This field defines the length of the Transmit Frame Sync signal and the number of bits shifted out from the Transmit Sync Data Register if FSDEN is 1.

- **FSOS: Transmit Frame Sync Output Selection**

| Value | Selected Transmit Frame Sync Signal | TF Pin |
|---------|---|------------|
| 0x0 | None | Input-only |
| 0x1 | Negative Pulse | Output |
| 0x2 | Positive Pulse | Output |
| 0x3 | Driven Low during data transfer | Output |
| 0x4 | Driven High during data transfer | Output |
| 0x5 | Toggling at each start of data transfer | Output |
| 0x6–0x7 | Reserved | Undefined |

- **FSDEN: Frame Sync Data Enable**

0: The TD line is driven with the default value during the Transmit Frame Sync signal.

1: SSC_TSHR value is shifted out during the transmission of the Transmit Frame Sync signal.

- **FSEEDGE: Frame Sync Edge Detection**

Determines which edge on frame sync will generate the interrupt TXSYN (Status Register).

| Value | Frame Sync Edge Detection |
|-------|---------------------------|
| 0x0 | Positive Edge Detection |
| 0x1 | Negative Edge Detection |

32.8.7 SSC Receive Holding Register

Name: SSC_RHR

Address: 0xFFFFBC020 (0), 0xFFFFC0020 (1), 0xFFFFC4020 (2)

Access: Read-only

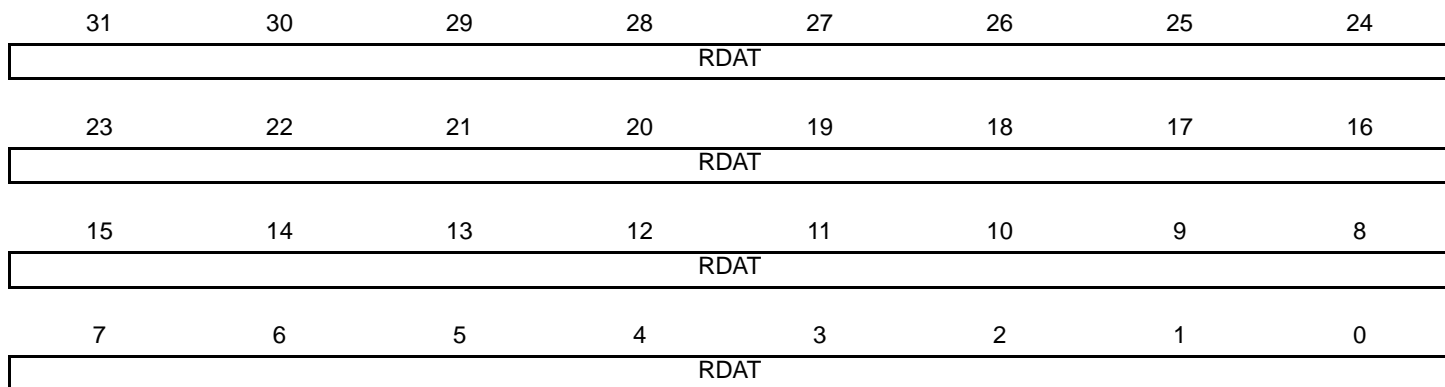

- **RDAT: Receive Data**

Right aligned regardless of the number of data bits defined by DATLEN in SSC_RFMR.

32.8.8 SSC Transmit Holding Register

Name: SSC_THR

Address: 0xFFFFBC024 (0), 0xFFFFC0024 (1), 0xFFFFC4024 (2)

Access: Write-only

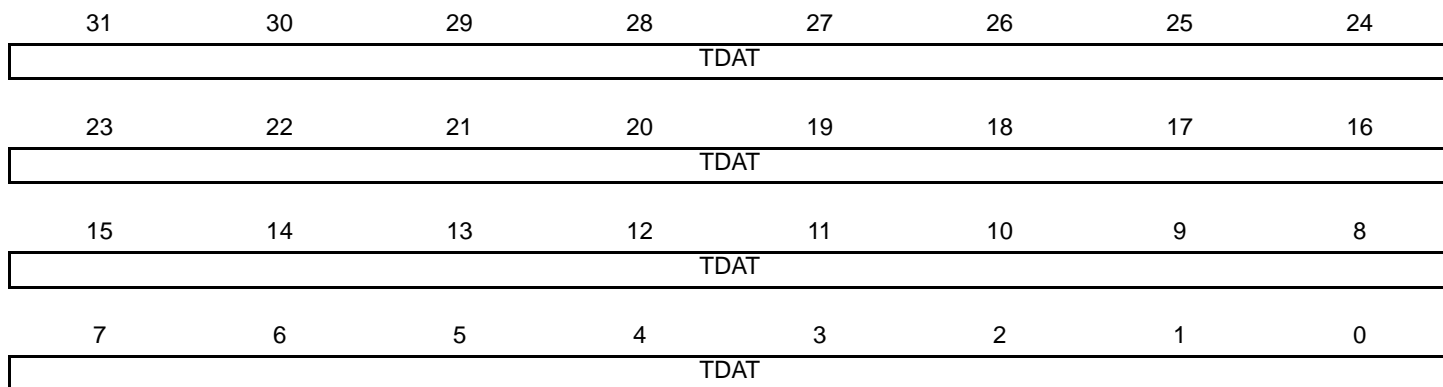

- **TDAT: Transmit Data**

Right aligned regardless of the number of data bits defined by DATLEN in SSC_TFMR.

32.8.9 SSC Receive Synchronization Holding Register

Name: SSC_RSHR

Address: 0xFFFFBC030 (0), 0xFFFC0030 (1), 0xFFFC4030 (2)

Access: Read-only

| | | | | | | | |
|-------|----|----|----|----|----|----|----|
| 31 | 30 | 29 | 28 | 27 | 26 | 25 | 24 |
| – | – | – | – | – | – | – | – |
| 23 | 22 | 21 | 20 | 19 | 18 | 17 | 16 |
| – | – | – | – | – | – | – | – |
| 15 | 14 | 13 | 12 | 11 | 10 | 9 | 8 |
| RSDAT | | | | | | | |
| 7 | 6 | 5 | 4 | 3 | 2 | 1 | 0 |
| RSDAT | | | | | | | |

- **RSDAT: Receive Synchronization Data**

32.8.10 SSC Transmit Synchronization Holding Register

Name: SSC_TSHR

Address: 0xFFFFBC034 (0), 0xFFFFC0034 (1), 0xFFFFC4034 (2)

Access: Read/Write

| | | | | | | | |
|-------|----|----|----|----|----|----|----|
| 31 | 30 | 29 | 28 | 27 | 26 | 25 | 24 |
| – | – | – | – | – | – | – | – |
| 23 | 22 | 21 | 20 | 19 | 18 | 17 | 16 |
| – | – | – | – | – | – | – | – |
| 15 | 14 | 13 | 12 | 11 | 10 | 9 | 8 |
| TSDAT | | | | | | | |
| 7 | 6 | 5 | 4 | 3 | 2 | 1 | 0 |
| TSDAT | | | | | | | |

- **TSDAT: Transmit Synchronization Data**

32.8.11 SSC Receive Compare 0 Register

Name: SSC_RC0R

Address: 0xFFFFBC038 (0), 0xFFFFC0038 (1), 0xFFFFC4038 (2)

Access: Read/Write

| | | | | | | | |
|-----|----|----|----|----|----|----|----|
| 31 | 30 | 29 | 28 | 27 | 26 | 25 | 24 |
| – | – | – | – | – | – | – | – |
| 23 | 22 | 21 | 20 | 19 | 18 | 17 | 16 |
| – | – | – | – | – | – | – | – |
| 15 | 14 | 13 | 12 | 11 | 10 | 9 | 8 |
| CP0 | | | | | | | |
| 7 | 6 | 5 | 4 | 3 | 2 | 1 | 0 |
| CP0 | | | | | | | |

- **CP0: Receive Compare Data 0**

32.8.12 SSC Receive Compare 1 Register

Name: SSC_RC1R

Address: 0xFFFFBC03C (0), 0xFFFFC003C (1), 0xFFFFC403C (2)

Access: Read/Write

| | | | | | | | |
|-----|----|----|----|----|----|----|----|
| 31 | 30 | 29 | 28 | 27 | 26 | 25 | 24 |
| – | – | – | – | – | – | – | – |
| 23 | 22 | 21 | 20 | 19 | 18 | 17 | 16 |
| – | – | – | – | – | – | – | – |
| 15 | 14 | 13 | 12 | 11 | 10 | 9 | 8 |
| CP1 | | | | | | | |
| 7 | 6 | 5 | 4 | 3 | 2 | 1 | 0 |
| CP1 | | | | | | | |

- **CP1: Receive Compare Data 1**

32.8.13 SSC Status Register

Name: SSC_SR

Address: 0xFFFFBC040 (0), 0xFFFFC0040 (1), 0xFFFFC4040 (2)

Access: Read-only

| | | | | | | | |
|--------|-------|-------|-------|--------|-------|---------|-------|
| 31 | 30 | 29 | 28 | 27 | 26 | 25 | 24 |
| – | – | – | – | – | – | – | – |
| 23 | 22 | 21 | 20 | 19 | 18 | 17 | 16 |
| – | – | – | – | – | – | RXEN | TXEN |
| 15 | 14 | 13 | 12 | 11 | 10 | 9 | 8 |
| – | – | – | – | RXSYN | TXSYN | CP1 | CP0 |
| 7 | 6 | 5 | 4 | 3 | 2 | 1 | 0 |
| RXBUFF | ENDRX | OVRUN | RXRDY | TXBUFE | ENDTX | TXEMPTY | TXRDY |

- **TXRDY: Transmit Ready**

0: Data has been loaded in SSC_THR and is waiting to be loaded in the Transmit Shift Register (TSR).

1: SSC_THR is empty.

- **TXEMPTY: Transmit Empty**

0: Data remains in SSC_THR or is currently transmitted from TSR.

1: Last data written in SSC_THR has been loaded in TSR and last data loaded in TSR has been transmitted.

- **ENDTX: End of Transmission**

0: The register SSC_TCR has not reached 0 since the last write in SSC_TCR or SSC_TNCR.

1: The register SSC_TCR has reached 0 since the last write in SSC_TCR or SSC_TNCR.

- **TXBUFE: Transmit Buffer Empty**

0: SSC_TCR or SSC_TNCR have a value other than 0.

1: Both SSC_TCR and SSC_TNCR have a value of 0.

- **RXRDY: Receive Ready**

0: SSC_RHR is empty.

1: Data has been received and loaded in SSC_RHR.

- **OVRUN: Receive Overrun**

0: No data has been loaded in SSC_RHR while previous data has not been read since the last read of the Status Register.

1: Data has been loaded in SSC_RHR while previous data has not yet been read since the last read of the Status Register.

- **ENDRX: End of Reception**

0: Data is written on the Receive Counter Register or Receive Next Counter Register.

1: End of PDC transfer when Receive Counter Register has arrived at zero.

- **RXBUFF: Receive Buffer Full**

0: SSC_RCR or SSC_RNCR have a value other than 0.

1: Both SSC_RCR and SSC_RNCR have a value of 0.

- **CP0: Compare 0**

0: A compare 0 has not occurred since the last read of the Status Register.

1: A compare 0 has occurred since the last read of the Status Register.

- **CP1: Compare 1**

0: A compare 1 has not occurred since the last read of the Status Register.

1: A compare 1 has occurred since the last read of the Status Register.

- **TXSYN: Transmit Sync**

0: A Tx Sync has not occurred since the last read of the Status Register.

1: A Tx Sync has occurred since the last read of the Status Register.

- **RXSYN: Receive Sync**

0: An Rx Sync has not occurred since the last read of the Status Register.

1: An Rx Sync has occurred since the last read of the Status Register.

- **TXEN: Transmit Enable**

0: Transmit is disabled.

1: Transmit is enabled.

- **RXEN: Receive Enable**

0: Receive is disabled.

1: Receive is enabled.

32.8.14 SSC Interrupt Enable Register

Name: SSC_IER

Address: 0xFFFFBC044 (0), 0xFFFFC0044 (1), 0xFFFFC4044 (2)

Access: Write-only

| | | | | | | | |
|--------|-------|-------|-------|--------|-------|---------|-------|
| 31 | 30 | 29 | 28 | 27 | 26 | 25 | 24 |
| – | – | – | – | – | – | – | – |
| 23 | 22 | 21 | 20 | 19 | 18 | 17 | 16 |
| – | – | – | – | – | – | – | – |
| 15 | 14 | 13 | 12 | 11 | 10 | 9 | 8 |
| – | – | – | – | RXSYN | TXSYN | CP1 | CP0 |
| 7 | 6 | 5 | 4 | 3 | 2 | 1 | 0 |
| RXBUFF | ENDRX | OVRUN | RXRDY | TXBUFE | ENDTX | TXEMPTY | TXRDY |

- **TXRDY: Transmit Ready Interrupt Enable**

0: No effect.

1: Enables the Transmit Ready Interrupt.

- **TXEMPTY: Transmit Empty Interrupt Enable**

0: No effect.

1: Enables the Transmit Empty Interrupt.

- **ENDTX: End of Transmission Interrupt Enable**

0: No effect.

1: Enables the End of Transmission Interrupt.

- **TXBUFE: Transmit Buffer Empty Interrupt Enable**

0: No effect.

1: Enables the Transmit Buffer Empty Interrupt

- **RXRDY: Receive Ready Interrupt Enable**

0: No effect.

1: Enables the Receive Ready Interrupt.

- **OVRUN: Receive Overrun Interrupt Enable**

0: No effect.

1: Enables the Receive Overrun Interrupt.

- **ENDRX: End of Reception Interrupt Enable**

0: No effect.

1: Enables the End of Reception Interrupt.

- **RXBUFF: Receive Buffer Full Interrupt Enable**

0: No effect.

1: Enables the Receive Buffer Full Interrupt.

- **CP0: Compare 0 Interrupt Enable**

0: No effect.

1: Enables the Compare 0 Interrupt.

- **CP1: Compare 1 Interrupt Enable**

0: No effect.

1: Enables the Compare 1 Interrupt.

- **TXSYN: Tx Sync Interrupt Enable**

0: No effect.

1: Enables the Tx Sync Interrupt.

- **RXSYN: Rx Sync Interrupt Enable**

0: No effect.

1: Enables the Rx Sync Interrupt.

32.8.15 SSC Interrupt Disable Register

Name: SSC_IDR

Address: 0xFFFFBC048 (0), 0xFFFFC0048 (1), 0xFFFFC4048 (2)

Access: Write-only

| | | | | | | | |
|--------|-------|-------|-------|--------|-------|---------|-------|
| 31 | 30 | 29 | 28 | 27 | 26 | 25 | 24 |
| – | – | – | – | – | – | – | – |
| 23 | 22 | 21 | 20 | 19 | 18 | 17 | 16 |
| – | – | – | – | – | – | – | – |
| 15 | 14 | 13 | 12 | 11 | 10 | 9 | 8 |
| – | – | – | – | RXSYN | TXSYN | CP1 | CP0 |
| 7 | 6 | 5 | 4 | 3 | 2 | 1 | 0 |
| RXBUFF | ENDRX | OVRUN | RXRDY | TXBUFE | ENDTX | TXEMPTY | TXRDY |

- **TXRDY: Transmit Ready Interrupt Disable**

0: No effect.

1: Disables the Transmit Ready Interrupt.

- **TXEMPTY: Transmit Empty Interrupt Disable**

0: No effect.

1: Disables the Transmit Empty Interrupt.

- **ENDTX: End of Transmission Interrupt Disable**

0: No effect.

1: Disables the End of Transmission Interrupt.

- **TXBUFE: Transmit Buffer Empty Interrupt Disable**

0: No effect.

1: Disables the Transmit Buffer Empty Interrupt.

- **RXRDY: Receive Ready Interrupt Disable**

0: No effect.

1: Disables the Receive Ready Interrupt.

- **OVRUN: Receive Overrun Interrupt Disable**

0: No effect.

1: Disables the Receive Overrun Interrupt.

- **ENDRX: End of Reception Interrupt Disable**

0: No effect.

1: Disables the End of Reception Interrupt.

- **RXBUFF: Receive Buffer Full Interrupt Disable**

0: No effect.

1: Disables the Receive Buffer Full Interrupt.

- **CP0: Compare 0 Interrupt Disable**

0: No effect.

1: Disables the Compare 0 Interrupt.

- **CP1: Compare 1 Interrupt Disable**

0: No effect.

1: Disables the Compare 1 Interrupt.

- **TXSYN: Tx Sync Interrupt Enable**

0: No effect.

1: Disables the Tx Sync Interrupt.

- **RXSYN: Rx Sync Interrupt Enable**

0: No effect.

1: Disables the Rx Sync Interrupt.

32.8.16 SSC Interrupt Mask Register

Name: SSC_IMR

Address: 0xFFFFBC04C (0), 0xFFFFC004C (1), 0xFFFFC404C (2)

Access: Read-only

| | | | | | | | |
|-------|-------|-------|-------|--------|-------|---------|-------|
| 31 | 30 | 29 | 28 | 27 | 26 | 25 | 24 |
| – | – | – | – | – | – | – | – |
| 23 | 22 | 21 | 20 | 19 | 18 | 17 | 16 |
| – | – | – | – | – | – | – | – |
| 15 | 14 | 13 | 12 | 11 | 10 | 9 | 8 |
| – | – | – | – | RXSYN | TXSYN | CP1 | CP0 |
| 7 | 6 | 5 | 4 | 3 | 2 | 1 | 0 |
| RXBUF | ENDRX | OVRUN | RXRDY | TXBUFE | ENDTX | TXEMPTY | TXRDY |

- **TXRDY: Transmit Ready Interrupt Mask**

0: The Transmit Ready Interrupt is disabled.

1: The Transmit Ready Interrupt is enabled.

- **TXEMPTY: Transmit Empty Interrupt Mask**

0: The Transmit Empty Interrupt is disabled.

1: The Transmit Empty Interrupt is enabled.

- **ENDTX: End of Transmission Interrupt Mask**

0: The End of Transmission Interrupt is disabled.

1: The End of Transmission Interrupt is enabled.

- **TXBUFE: Transmit Buffer Empty Interrupt Mask**

0: The Transmit Buffer Empty Interrupt is disabled.

1: The Transmit Buffer Empty Interrupt is enabled.

- **RXRDY: Receive Ready Interrupt Mask**

0: The Receive Ready Interrupt is disabled.

1: The Receive Ready Interrupt is enabled.

- **OVRUN: Receive Overrun Interrupt Mask**

0: The Receive Overrun Interrupt is disabled.

1: The Receive Overrun Interrupt is enabled.

- **ENDRX: End of Reception Interrupt Mask**

0: The End of Reception Interrupt is disabled.

1: The End of Reception Interrupt is enabled.

- **RXBUFF: Receive Buffer Full Interrupt Mask**

0: The Receive Buffer Full Interrupt is disabled.

1: The Receive Buffer Full Interrupt is enabled.

- **CP0: Compare 0 Interrupt Mask**

0: The Compare 0 Interrupt is disabled.

1: The Compare 0 Interrupt is enabled.

- **CP1: Compare 1 Interrupt Mask**

0: The Compare 1 Interrupt is disabled.

1: The Compare 1 Interrupt is enabled.

- **TXSYN: Tx Sync Interrupt Mask**

0: The Tx Sync Interrupt is disabled.

1: The Tx Sync Interrupt is enabled.

- **RXSYN: Rx Sync Interrupt Mask**

0: The Rx Sync Interrupt is disabled.

1: The Rx Sync Interrupt is enabled.

33. Timer Counter (TC)

33.1 Overview

The Timer Counter (TC) includes three identical 16-bit Timer Counter channels.

Each channel can be independently programmed to perform a wide range of functions including frequency measurement, event counting, interval measurement, pulse generation, delay timing and pulse width modulation.

Each channel has three external clock inputs, five internal clock inputs and two multi-purpose input/output signals which can be configured by the user. Each channel drives an internal interrupt signal which can be programmed to generate processor interrupts.

The Timer Counter block has two global registers which act upon all three TC channels.

The Block Control Register allows the three channels to be started simultaneously with the same instruction.

The Block Mode Register defines the external clock inputs for each channel, allowing them to be chained.

[Table 33-1](#) gives the assignment of the device Timer Counter clock inputs common to Timer Counter 0 to 2

Table 33-1. Timer Counter Clock Assignment

| Name | Definition |
|--------------|------------|
| TIMER_CLOCK1 | MCK/2 |
| TIMER_CLOCK2 | MCK/8 |
| TIMER_CLOCK3 | MCK/32 |
| TIMER_CLOCK4 | MCK/128 |
| TIMER_CLOCK5 | SLCK |

33.2 Embedded Characteristics

- Three 16-bit Timer Counter Channels
- Wide range of functions including:
 - Frequency Measurement
 - Event Counting
 - Interval Measurement
 - Pulse Generation
 - Delay Timing
 - Pulse Width Modulation
 - Up/down Capabilities
- Each channel is user-configurable and contains:
 - Three external clock inputs
 - Five internal clock inputs
 - Two multi-purpose input/output signals
- Two global registers that act on all three TC Channels

33.3 Block Diagram

Figure 33-1. Timer Counter Block Diagram

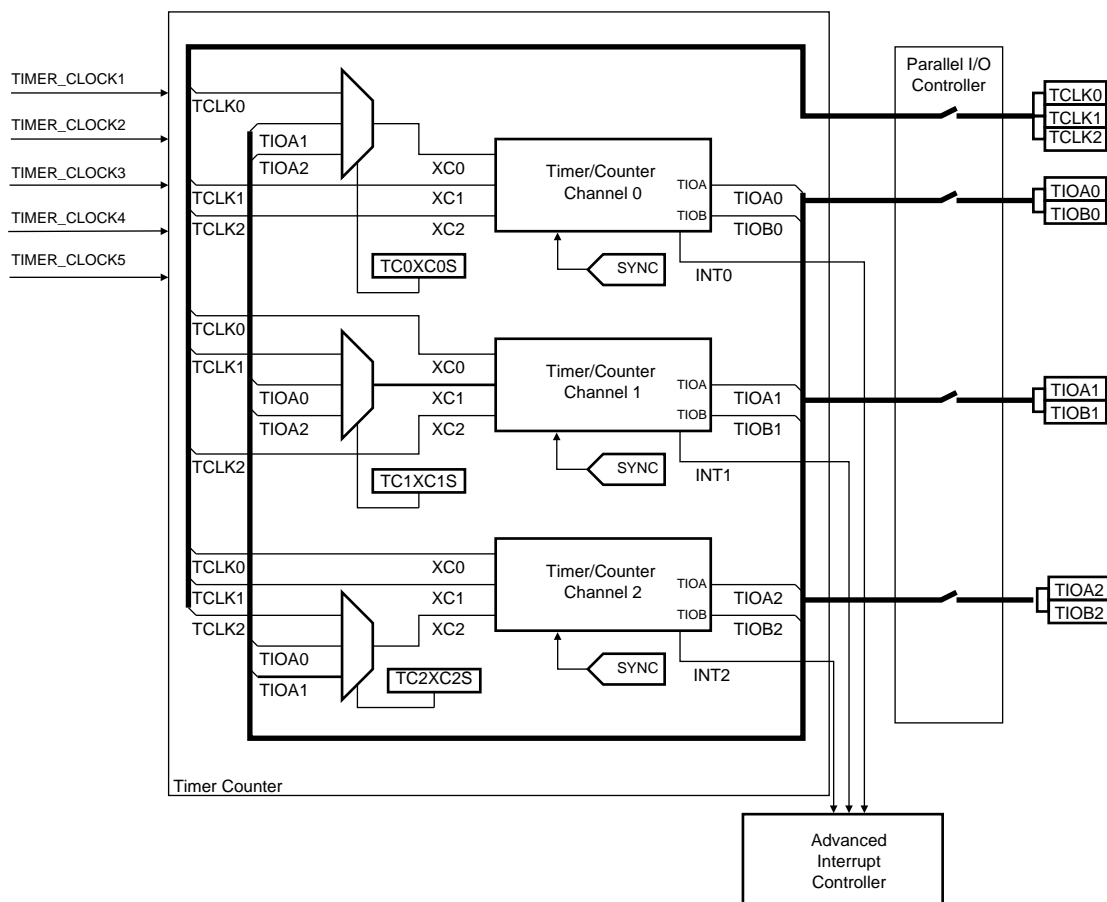

Table 33-2. Channel Signal Description

| Signal Name | Description |
|---------------|--|
| XC0, XC1, XC2 | External Clock Inputs |
| TIOA | Capture Mode: Timer Counter Input Waveform Mode: Timer Counter Output |
| TIOB | Capture Mode: Timer Counter Input Waveform Mode: Timer Counter Input/Output |
| INT | Interrupt Signal Output |
| SYNC | Synchronization Input Signal |

33.4 Pin Name List

Table 33-3. TC Pin List

| Pin Name | Description | Type |
|-------------|----------------------|-------|
| TCLK0–TCLK2 | External Clock Input | Input |
| TIOA0–TIOA2 | I/O Line A | I/O |
| TIOB0–TIOB2 | I/O Line B | I/O |

33.5 Product Dependencies

33.5.1 I/O Lines

The pins used for interfacing the compliant external devices may be multiplexed with PIO lines. The programmer must first program the PIO controllers to assign the TC pins to their peripheral functions.

33.5.2 Power Management

The TC is clocked through the Power Management Controller (PMC), thus the programmer must first configure the PMC to enable the Timer Counter clock.

33.5.3 Interrupt

The TC has an interrupt line connected to the Advanced Interrupt Controller (AIC). Handling the TC interrupt requires programming the AIC before configuring the TC.

33.6 Functional Description

33.6.1 TC Description

The three channels of the Timer Counter are independent and identical in operation. The registers for channel programming are listed in [Table 33-4 on page 528](#).

33.6.2 16-bit Counter

Each channel is organized around a 16-bit counter. The value of the counter is incremented at each positive edge of the selected clock. When the counter has reached the value 0xFFFF and passes to 0x0000, an overflow occurs and the COVFS bit in TC_SR (Status Register) is set.

The current value of the counter is accessible in real time by reading the Counter Value Register, TC_CV. The counter can be reset by a trigger. In this case, the counter value passes to 0x0000 on the next valid edge of the selected clock.

33.6.3 Clock Selection

At block level, input clock signals of each channel can either be connected to the external inputs TCLK0, TCLK1 or TCLK2, or be connected to the internal I/O signals TIOA0, TIOA1 or TIOA2 for chaining by programming the TC_BMR (Block Mode). See [Figure 33-2 on page 517](#).

Each channel can independently select an internal or external clock source for its counter:

- Internal clock signals: TIMER_CLOCK1, TIMER_CLOCK2, TIMER_CLOCK3, TIMER_CLOCK4, TIMER_CLOCK5
- External clock signals: XC0, XC1 or XC2

This selection is made by the TCCLKS bits in the TC Channel Mode Register.

The selected clock can be inverted with the CLKI bit in TC_CMR. This allows counting on the opposite edges of the clock.

The burst function allows the clock to be validated when an external signal is high. The BURST parameter in the Mode Register defines this signal (none, XC0, XC1, XC2). See [Figure 33-3 on page 517](#)

Note: In all cases, if an external clock is used, the duration of each of its levels must be longer than the master clock period. The external clock frequency must be at least 2.5 times lower than the master clock

Figure 33-2. Clock Chaining Selection

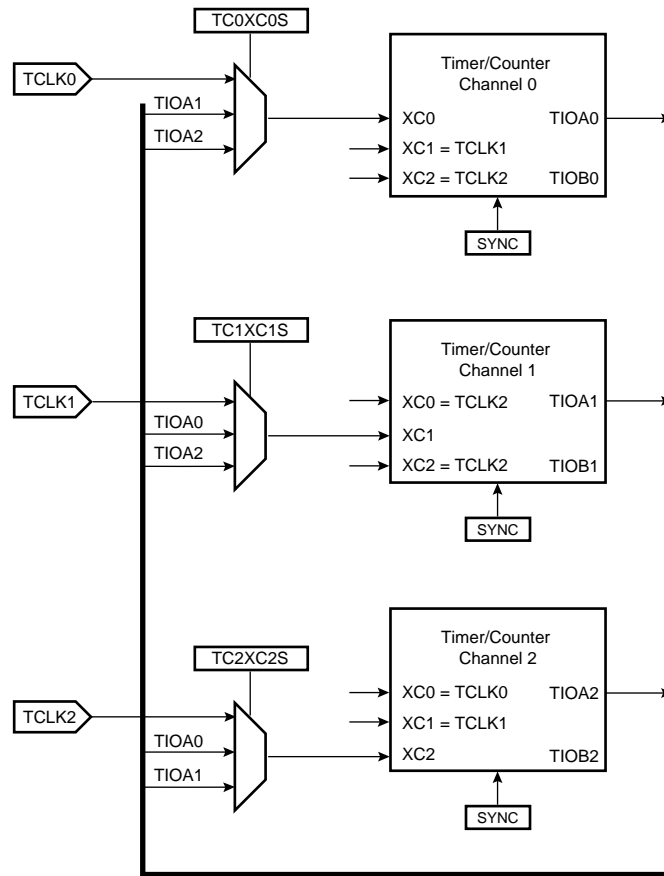
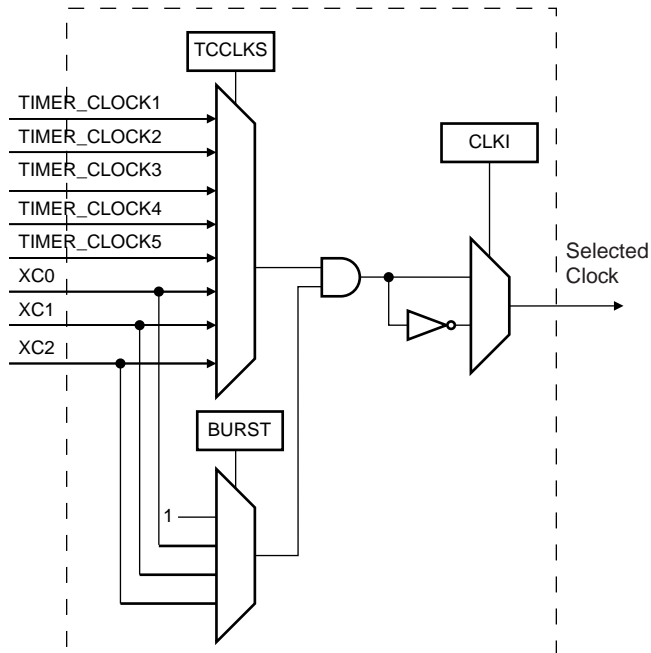

Figure 33-3. Clock Selection



33.6.4 Clock Control

The clock of each counter can be controlled in two different ways: it can be enabled/disabled and started/stopped. See Figure 33-4.

- The clock can be enabled or disabled by the user with the CLKEN and the CLKDIS commands in the Control Register. In Capture Mode it can be disabled by an RB load event if LDBDIS is set to 1 in TC_CMR. In Waveform Mode, it can be disabled by an RC Compare event if CPCDIS is set to 1 in TC_CMR. When disabled, the start or the stop actions have no effect: only a CLKEN command in the Control Register can re-enable the clock. When the clock is enabled, the CLKSTA bit is set in the Status Register.
- The clock can also be started or stopped: a trigger (software, synchro, external or compare) always starts the clock. The clock can be stopped by an RB load event in Capture Mode (LDBSTOP = 1 in TC_CMR) or a RC compare event in Waveform Mode (CPCSTOP = 1 in TC_CMR). The start and the stop commands have effect only if the clock is enabled.

Figure 33-4. Clock Control

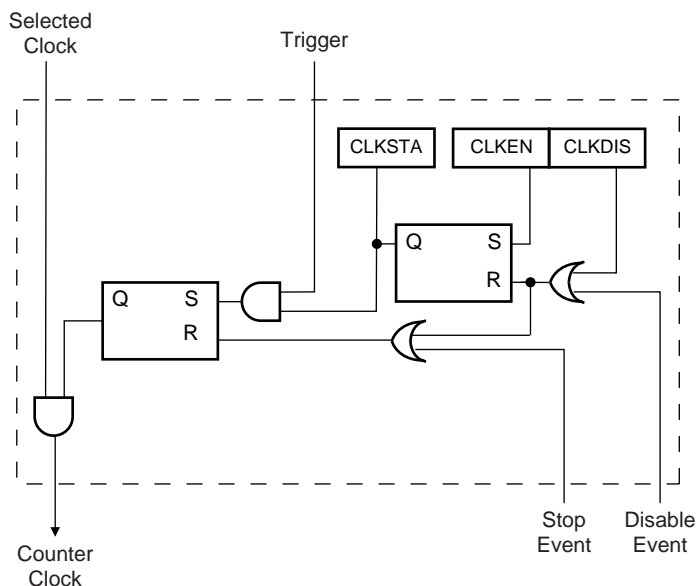

33.6.5 TC Operating Modes

Each channel can independently operate in two different modes:

- Capture Mode provides measurement on signals.
- Waveform Mode provides wave generation.

The TC Operating Mode is programmed with the WAVE bit in the TC Channel Mode Register.

In Capture Mode, TIOA and TIOB are configured as inputs.

In Waveform Mode, TIOA is always configured to be an output and TIOB is an output if it is not selected to be the external trigger.

33.6.6 Trigger

A trigger resets the counter and starts the counter clock. Three types of triggers are common to both modes, and a fourth external trigger is available to each mode.

The following triggers are common to both modes:

- Software Trigger: Each channel has a software trigger, available by setting SWTRG in TC_CCR.
- SYNC: Each channel has a synchronization signal SYNC. When asserted, this signal has the same effect as a software trigger. The SYNC signals of all channels are asserted simultaneously by writing TC_BCR (Block Control) with SYNC set.
- Compare RC Trigger: RC is implemented in each channel and can provide a trigger when the counter value matches the RC value if CPCTRG is set in TC_CMR.

The channel can also be configured to have an external trigger. In Capture Mode, the external trigger signal can be selected between TIOA and TIOB. In Waveform Mode, an external event can be programmed on one of the following signals: TIOB, XC0, XC1 or XC2. This external event can then be programmed to perform a trigger by setting ENETRIG in TC_CMR.

If an external trigger is used, the duration of the pulses must be longer than the master clock period in order to be detected.

Regardless of the trigger used, it will be taken into account at the following active edge of the selected clock. This means that the counter value can be read differently from zero just after a trigger, especially when a low frequency signal is selected as the clock.

33.6.7 Capture Operating Mode

This mode is entered by clearing the WAVE parameter in TC_CMR (Channel Mode Register).

Capture Mode allows the TC channel to perform measurements such as pulse timing, frequency, period, duty cycle and phase on TIOA and TIOB signals which are considered as inputs.

Figure 33-5 shows the configuration of the TC channel when programmed in Capture Mode.

33.6.8 Capture Registers A and B

Registers A and B (RA and RB) are used as capture registers. This means that they can be loaded with the counter value when a programmable event occurs on the signal TIOA.

The LDRA parameter in TC_CMR defines the TIOA edge for the loading of register A, and the LDRB parameter defines the TIOA edge for the loading of Register B.

RA is loaded only if it has not been loaded since the last trigger or if RB has been loaded since the last loading of RA.

RB is loaded only if RA has been loaded since the last trigger or the last loading of RB.

Loading RA or RB before the read of the last value loaded sets the Overrun Error Flag (LOVRS) in TC_SR (Status Register). In this case, the old value is overwritten.

33.6.9 Trigger Conditions

In addition to the SYNC signal, the software trigger and the RC compare trigger, an external trigger can be defined.

The ABETRIG bit in TC_CMR selects TIOA or TIOB input signal as an external trigger. The ETRGEDG parameter defines the edge (rising, falling or both) detected to generate an external trigger. If ETRGEDG = 0 (none), the external trigger is disabled.

Figure 33-5. Capture Mode

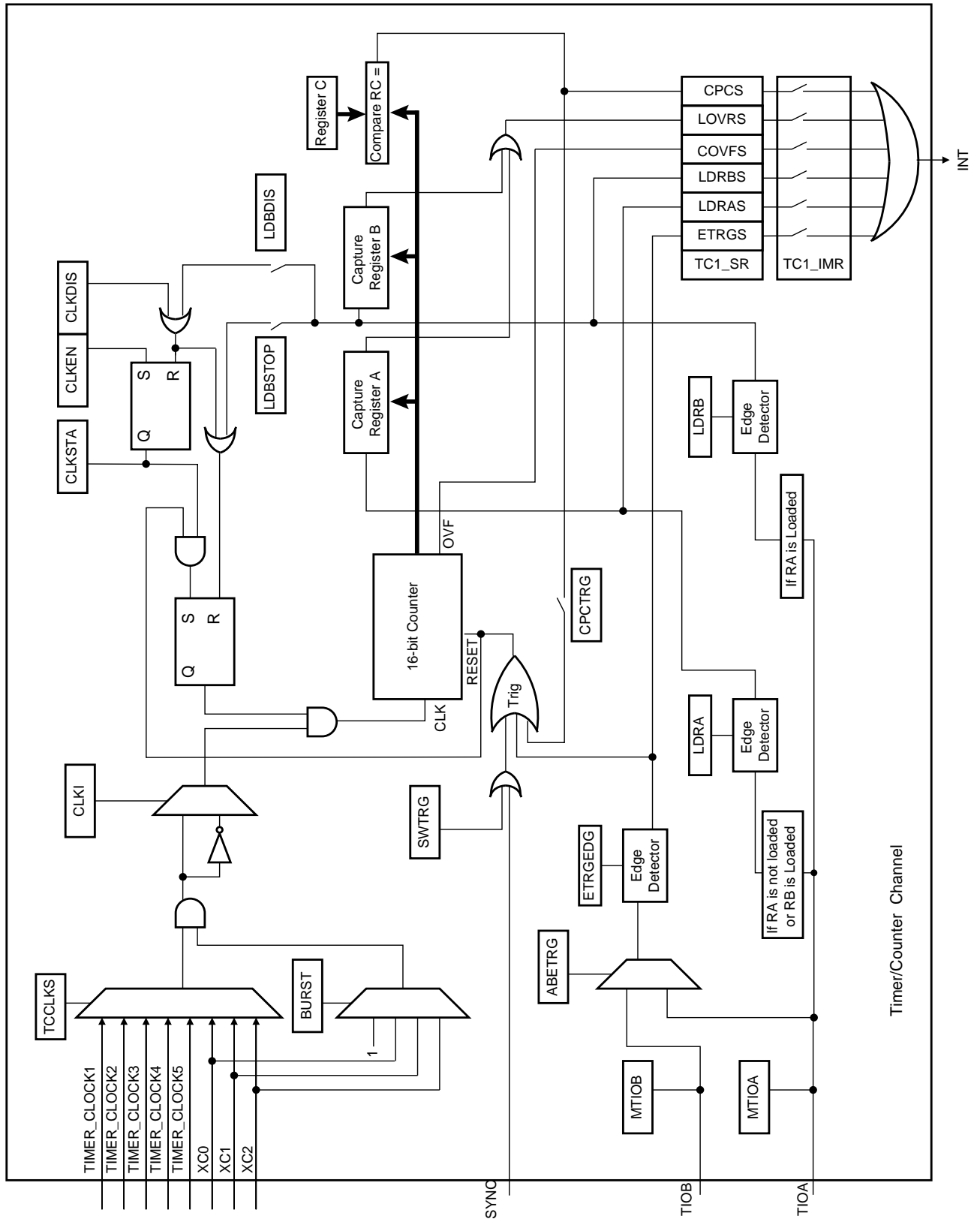

33.6.10 Waveform Operating Mode

Waveform operating mode is entered by setting the WAVE parameter in TC_CMR (Channel Mode Register).

In Waveform Operating Mode the TC channel generates 1 or 2 PWM signals with the same frequency and independently programmable duty cycles, or generates different types of one-shot or repetitive pulses.

In this mode, TIOA is configured as an output and TIOB is defined as an output if it is not used as an external event (EEVT parameter in TC_CMR).

[Figure 33-6](#) shows the configuration of the TC channel when programmed in Waveform Operating Mode.

33.6.11 Waveform Selection

Depending on the WAVSEL parameter in TC_CMR (Channel Mode Register), the behavior of TC_CV varies.

With any selection, RA, RB and RC can all be used as compare registers.

RA Compare is used to control the TIOA output, RB Compare is used to control the TIOB output (if correctly configured) and RC Compare is used to control TIOA and/or TIOB outputs.

Figure 33-6. Waveform Mode

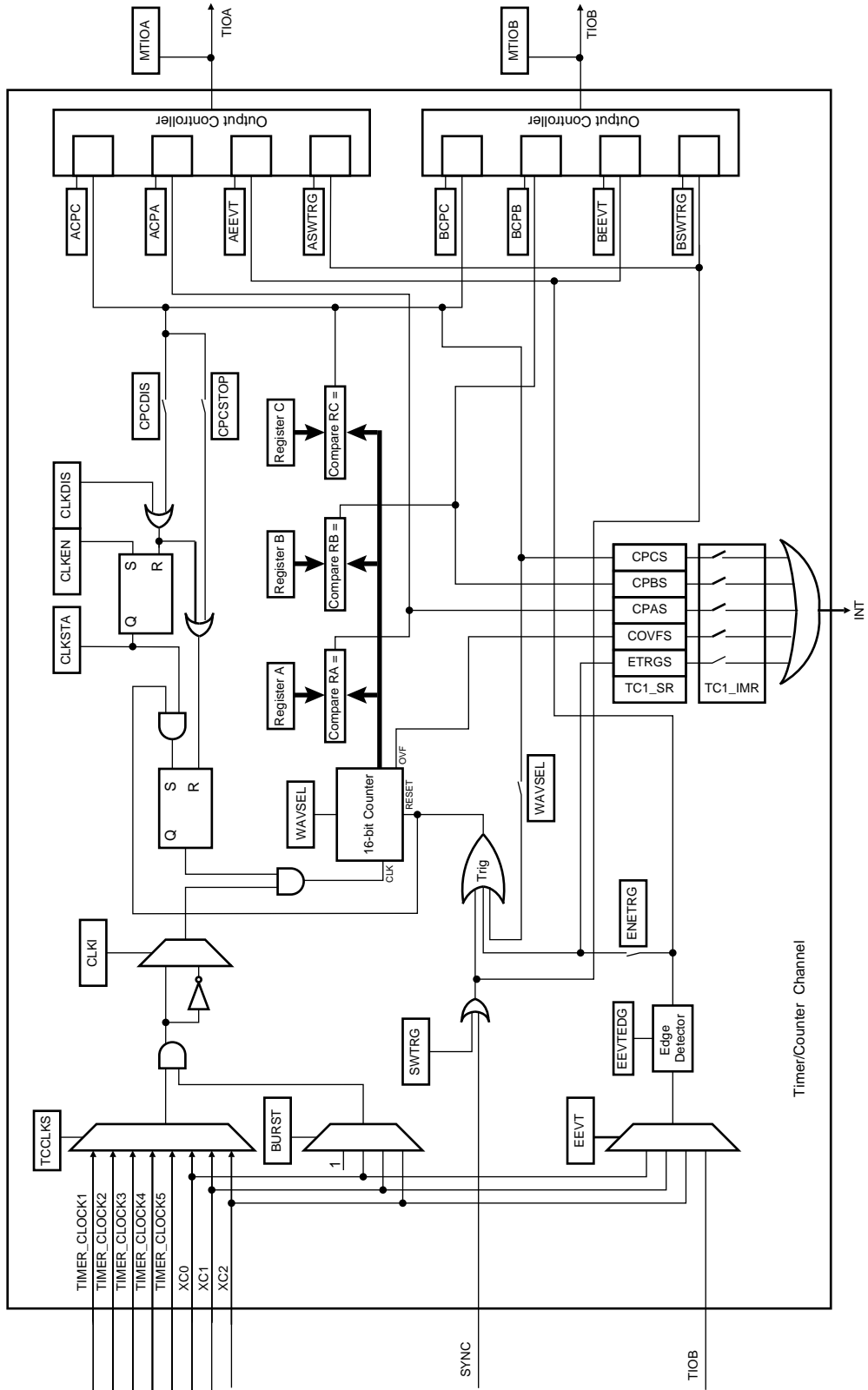

33.6.11.1 WAVSEL = 00

When WAVSEL = 00, the value of TC_CV is incremented from 0 to 0xFFFF. Once 0xFFFF has been reached, the value of TC_CV is reset. Incrementation of TC_CV starts again and the cycle continues. See [Figure 33-7](#).

An external event trigger or a software trigger can reset the value of TC_CV. It is important to note that the trigger may occur at any time. See [Figure 33-8](#).

RC Compare cannot be programmed to generate a trigger in this configuration. At the same time, RC Compare can stop the counter clock (CPCSTOP = 1 in TC_CMR) and/or disable the counter clock (CPCDIS = 1 in TC_CMR).

Figure 33-7. WAVSEL= 00 without trigger

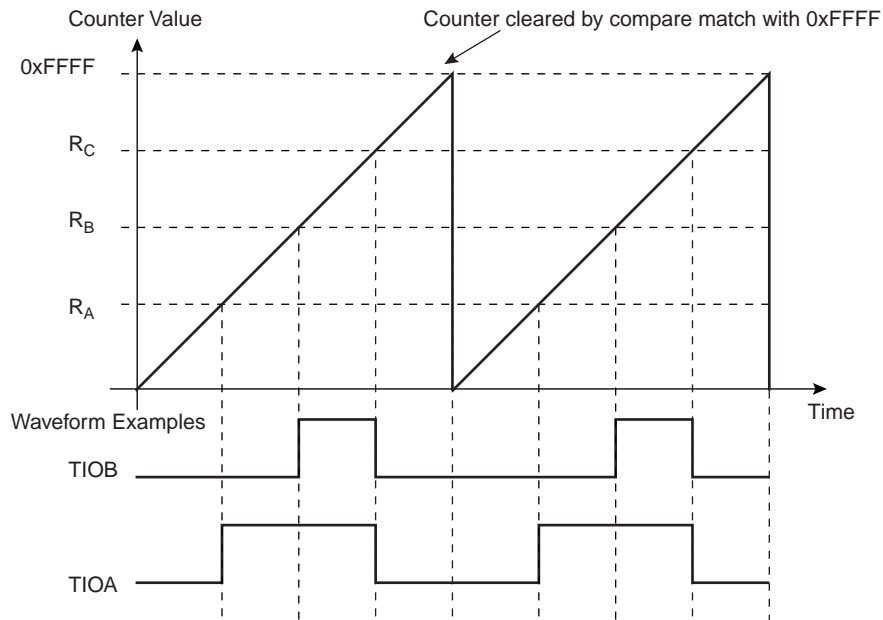
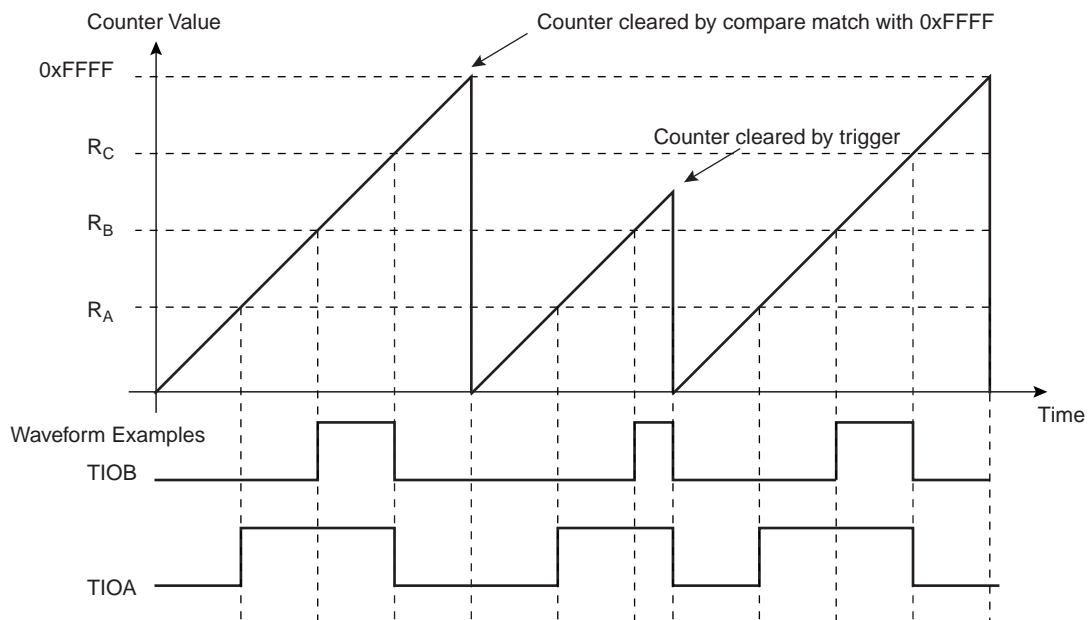

Figure 33-8. WAVSEL= 00 with trigger



33.6.11.2 WAVSEL = 10

When WAVSEL = 10, the value of TC_CV is incremented from 0 to the value of RC, then automatically reset on a RC Compare. Once the value of TC_CV has been reset, it is then incremented and so on. See [Figure 33-9](#).

It is important to note that TC_CV can be reset at any time by an external event or a software trigger if both are programmed correctly. See [Figure 33-10](#).

In addition, RC Compare can stop the counter clock (CPCSTOP = 1 in TC_CMR) and/or disable the counter clock (CPCDIS = 1 in TC_CMR).

Figure 33-9. WAVSEL = 10 Without Trigger

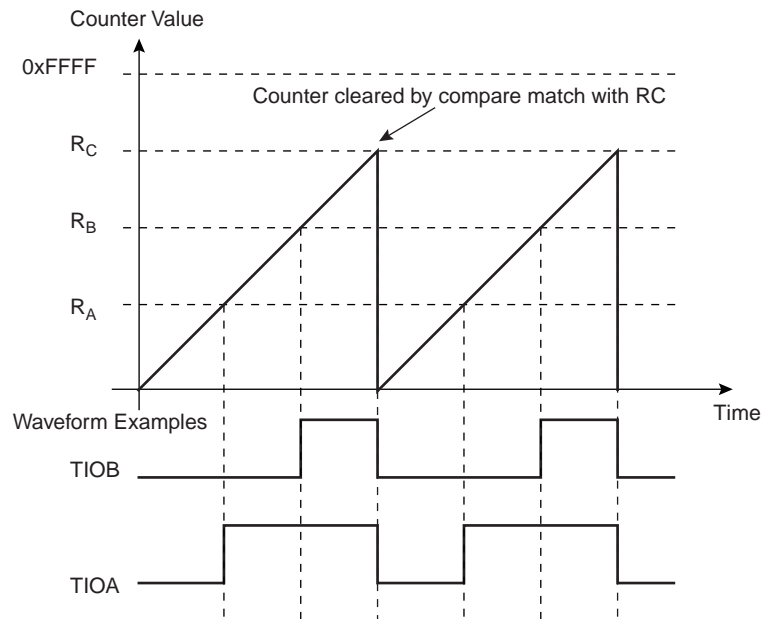
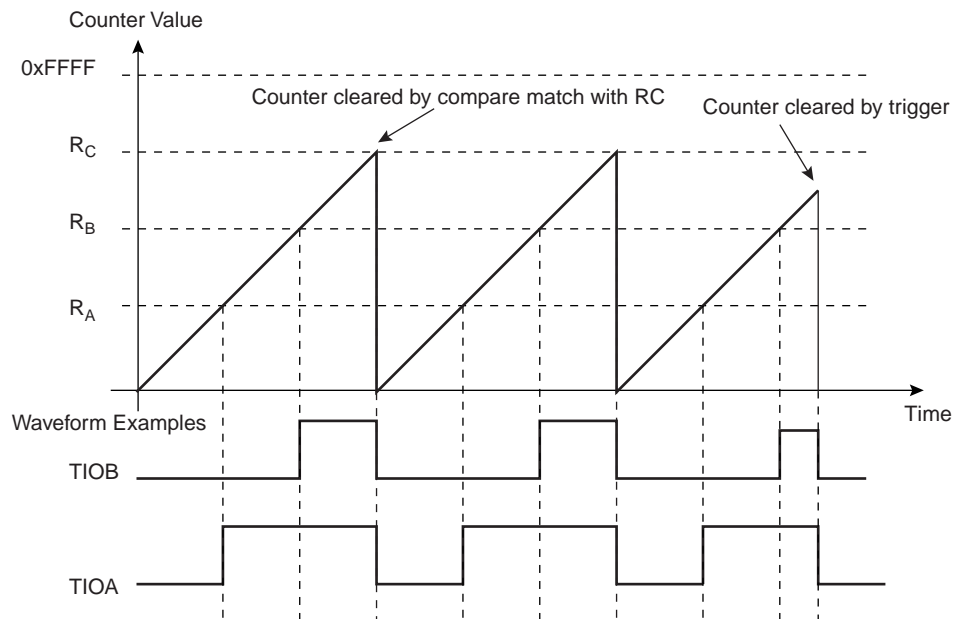

Figure 33-10. WAVSEL = 10 With Trigger



33.6.11.3 WAVSEL = 01

When WAVSEL = 01, the value of TC_CV is incremented from 0 to 0xFFFF. Once 0xFFFF is reached, the value of TC_CV is decremented to 0, then re-incremented to 0xFFFF and so on. See [Figure 33-11](#).

A trigger such as an external event or a software trigger can modify TC_CV at any time. If a trigger occurs while TC_CV is incrementing, TC_CV then decrements. If a trigger is received while TC_CV is decrementing, TC_CV then increments. See [Figure 33-12](#).

RC Compare cannot be programmed to generate a trigger in this configuration.

At the same time, RC Compare can stop the counter clock (CPCSTOP = 1) and/or disable the counter clock (CPCDIS = 1).

Figure 33-11. WAVSEL = 01 Without Trigger

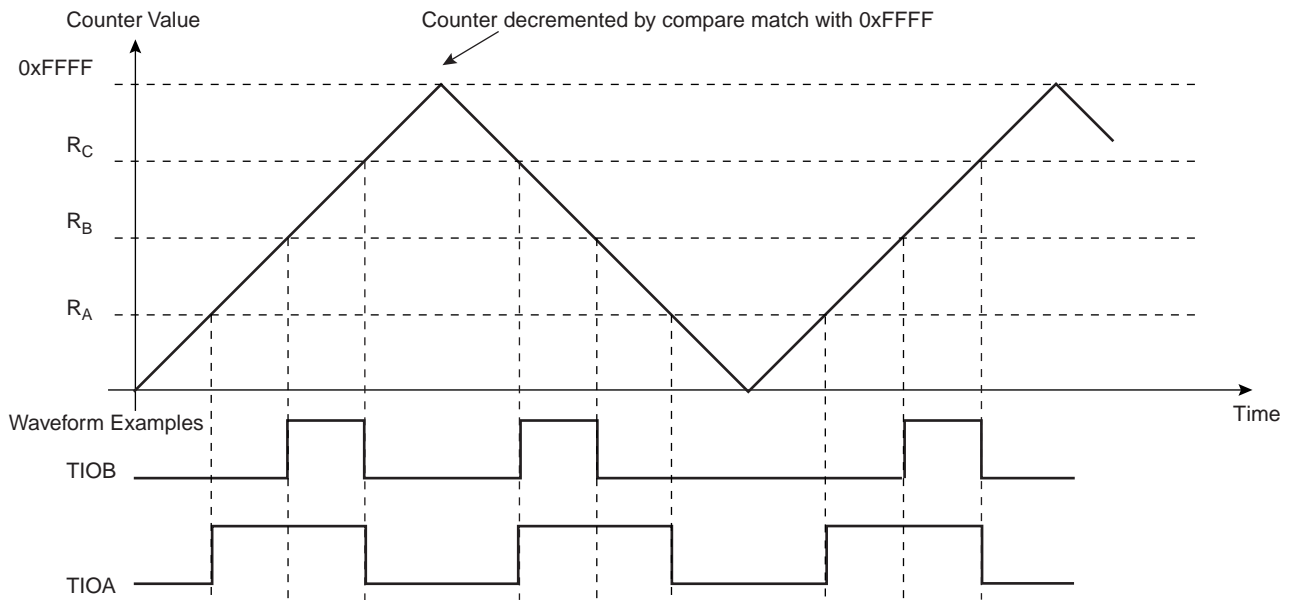
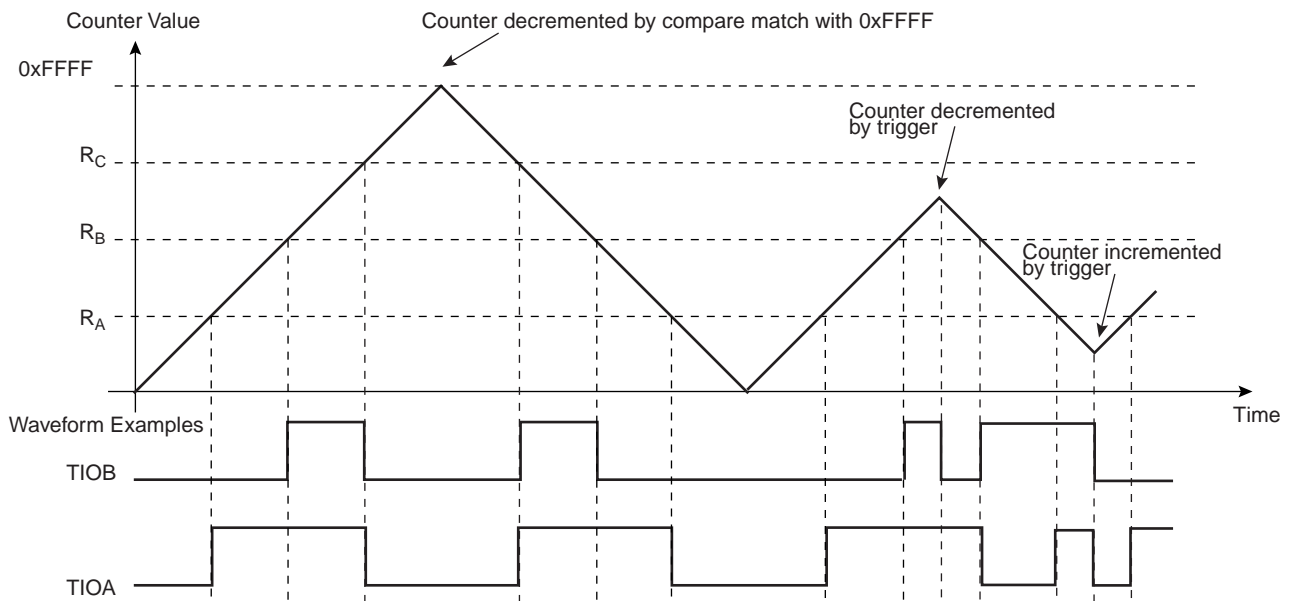

Figure 33-12. WAVSEL = 01 With Trigger



33.6.11.4 WAVSEL = 11

When WAVSEL = 11, the value of TC_CV is incremented from 0 to RC. Once RC is reached, the value of TC_CV is decremented to 0, then re-incremented to RC and so on. See [Figure 33-13](#).

A trigger such as an external event or a software trigger can modify TC_CV at any time. If a trigger occurs while TC_CV is incrementing, TC_CV then decrements. If a trigger is received while TC_CV is decrementing, TC_CV then increments. See [Figure 33-14](#).

RC Compare can stop the counter clock (CPCSTOP = 1) and/or disable the counter clock (CPCDIS = 1).

Figure 33-13. WAVSEL = 11 Without Trigger

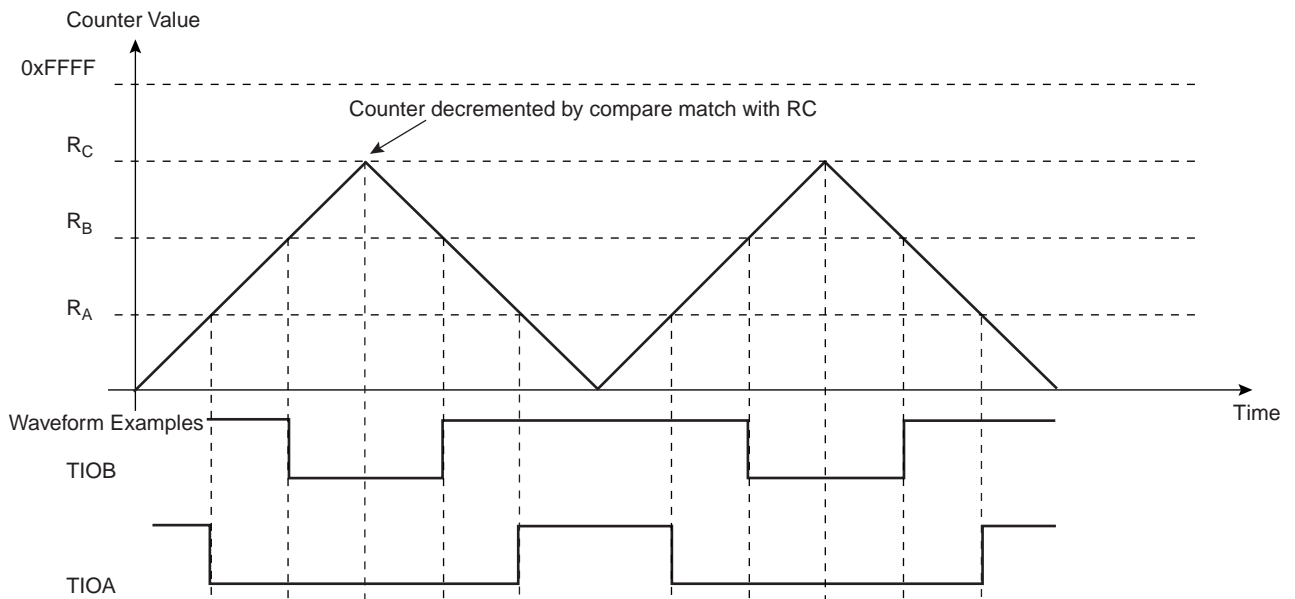
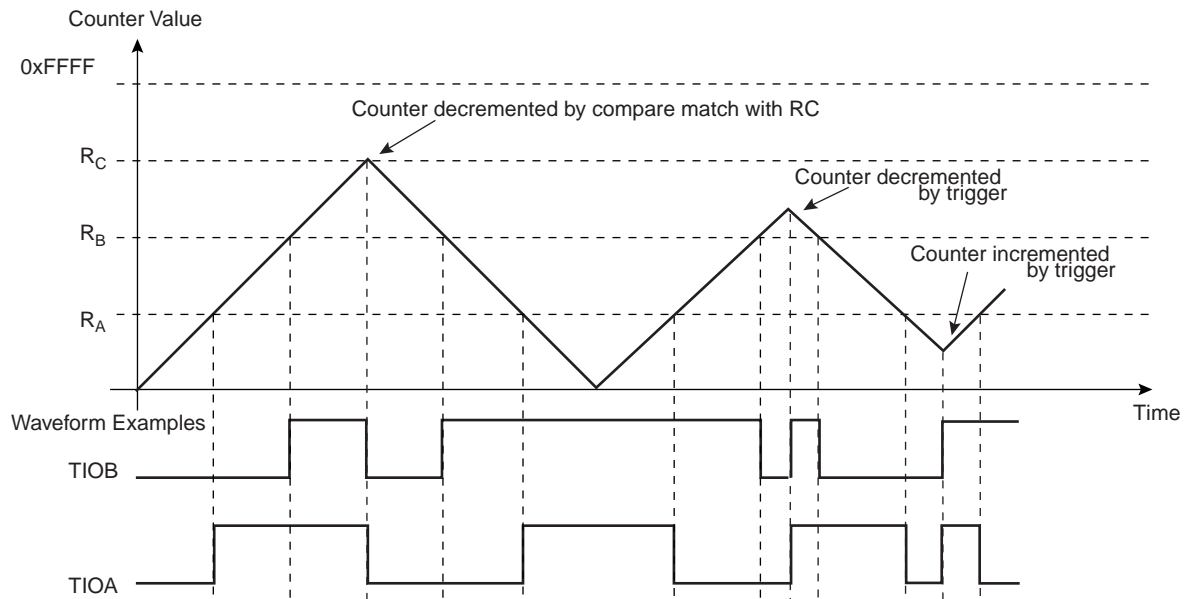

Figure 33-14. WAVSEL = 11 With Trigger



33.6.12 External Event/Trigger Conditions

An external event can be programmed to be detected on one of the clock sources (XC0, XC1, XC2) or TIOB. The external event selected can then be used as a trigger.

The EEVT parameter in TC_CMR selects the external trigger. The EEVTEDG parameter defines the trigger edge for each of the possible external triggers (rising, falling or both). If EEVTEDG is cleared (none), no external event is defined.

If TIOB is defined as an external event signal (EEVT = 0), TIOB is no longer used as an output and the compare register B is not used to generate waveforms and subsequently no IRQs. In this case the TC channel can only generate a waveform on TIOA.

When an external event is defined, it can be used as a trigger by setting bit ENETRIG in TC_CMR.

As in Capture Mode, the SYNC signal and the software trigger are also available as triggers. RC Compare can also be used as a trigger depending on the parameter WAVSEL.

33.6.13 Output Controller

The output controller defines the output level changes on TIOA and TIOB following an event. TIOB control is used only if TIOB is defined as output (not as an external event).

The following events control TIOA and TIOB: software trigger, external event and RC compare. RA compare controls TIOA and RB compare controls TIOB. Each of these events can be programmed to set, clear or toggle the output as defined in the corresponding parameter in TC_CMR.

33.7 Timer Counter (TC) User Interface

Table 33-4. Register Mapping

| Offset ⁽¹⁾ | Register | Name | Access | Reset |
|------------------------------|----------------------------|--------|---------------------------|-------|
| 0x00 + channel * 0x40 + 0x00 | Channel Control Register | TC_CCR | Write-only | – |
| 0x00 + channel * 0x40 + 0x04 | Channel Mode Register | TC_CMR | Read/Write | 0 |
| 0x00 + channel * 0x40 + 0x08 | Reserved | – | – | – |
| 0x00 + channel * 0x40 + 0x0C | Reserved | – | – | – |
| 0x00 + channel * 0x40 + 0x10 | Counter Value | TC_CV | Read-only | 0 |
| 0x00 + channel * 0x40 + 0x14 | Register A | TC_RA | Read/Write ⁽²⁾ | 0 |
| 0x00 + channel * 0x40 + 0x18 | Register B | TC_RB | Read/Write ⁽²⁾ | 0 |
| 0x00 + channel * 0x40 + 0x1C | Register C | TC_RC | Read/Write | 0 |
| 0x00 + channel * 0x40 + 0x20 | Status Register | TC_SR | Read-only | 0 |
| 0x00 + channel * 0x40 + 0x24 | Interrupt Enable Register | TC_IER | Write-only | – |
| 0x00 + channel * 0x40 + 0x28 | Interrupt Disable Register | TC_IDR | Write-only | – |
| 0x00 + channel * 0x40 + 0x2C | Interrupt Mask Register | TC_IMR | Read-only | 0 |
| 0xC0 | Block Control Register | TC_BCR | Write-only | – |
| 0xC4 | Block Mode Register | TC_BMR | Read/Write | 0 |
| 0xFC | Reserved | – | – | – |

- Notes: 1. Channel index ranges from 0 to 2.
2. Read-only if WAVE = 0

33.7.1 TC Block Control Register

Name: TC_BCR

Address: 0xFFFA00C0

Access: Write-only

| | | | | | | | |
|----|----|----|----|----|----|----|------|
| 31 | 30 | 29 | 28 | 27 | 26 | 25 | 24 |
| – | – | – | – | – | – | – | – |
| 23 | 22 | 21 | 20 | 19 | 18 | 17 | 16 |
| – | – | – | – | – | – | – | – |
| 15 | 14 | 13 | 12 | 11 | 10 | 9 | 8 |
| – | – | – | – | – | – | – | – |
| 7 | 6 | 5 | 4 | 3 | 2 | 1 | 0 |
| – | – | – | – | – | – | – | SYNC |

- **SYNC: Synchro Command**

0: No effect.

1: Asserts the SYNC signal which generates a software trigger simultaneously for each of the channels.

33.7.2 TC Block Mode Register

Name: TC_BMR

Address: 0xFFFA00C4

Access: Read/Write

| | | | | | | | |
|----|----|---------|----|---------|----|---------|----|
| 31 | 30 | 29 | 28 | 27 | 26 | 25 | 24 |
| – | – | – | – | – | – | – | – |
| 23 | 22 | 21 | 20 | 19 | 18 | 17 | 16 |
| – | – | – | – | – | – | – | – |
| 15 | 14 | 13 | 12 | 11 | 10 | 9 | 8 |
| – | – | – | – | – | – | – | – |
| 7 | 6 | 5 | 4 | 3 | 2 | 1 | 0 |
| – | – | TC2XC2S | | TC1XC1S | | TC0XC0S | |

• TC0XC0S: External Clock Signal 0 Selection

| Value | | Signal Connected to XC0 |
|-------|---|-------------------------|
| 0 | 0 | TCLK0 |
| 0 | 1 | none |
| 1 | 0 | TIOA1 |
| 1 | 1 | TIOA2 |

• TC1XC1S: External Clock Signal 1 Selection

| Value | | Signal Connected to XC1 |
|-------|---|-------------------------|
| 0 | 0 | TCLK1 |
| 0 | 1 | none |
| 1 | 0 | TIOA0 |
| 1 | 1 | TIOA2 |

• TC2XC2S: External Clock Signal 2 Selection

| Value | | Signal Connected to XC2 |
|-------|---|-------------------------|
| 0 | 0 | TCLK2 |
| 0 | 1 | none |
| 1 | 0 | TIOA0 |
| 1 | 1 | TIOA1 |

33.7.3 TC Channel Control Register

Name: TC_CCRx [x=0..2]

Address: 0xFFFA0000 (0)[0], 0xFFFA0040 (0)[1], 0xFFFA0080 (0)[2]

Access: Write-only

| | | | | | | | |
|----|----|----|----|----|-------|--------|-------|
| 31 | 30 | 29 | 28 | 27 | 26 | 25 | 24 |
| – | – | – | – | – | – | – | – |
| 23 | 22 | 21 | 20 | 19 | 18 | 17 | 16 |
| – | – | – | – | – | – | – | – |
| 15 | 14 | 13 | 12 | 11 | 10 | 9 | 8 |
| – | – | – | – | – | – | – | – |
| 7 | 6 | 5 | 4 | 3 | 2 | 1 | 0 |
| – | – | – | – | – | SWTRG | CLKDIS | CLKEN |

- **CLKEN: Counter Clock Enable Command**

0: No effect.

1: Enables the clock if CLKDIS is not 1.

- **CLKDIS: Counter Clock Disable Command**

0: No effect.

1: Disables the clock.

- **SWTRG: Software Trigger Command**

0: No effect.

1: A software trigger is performed: the counter is reset and the clock is started.

33.7.4 TC Channel Mode Register: Capture Mode

Name: TC_CMRx [x=0..2] (WAVE = 0)

Address: 0xFFFA0004 (0)[0], 0xFFFA0044 (0)[1], 0xFFFA0084 (0)[2]

Access: Read/Write

| | | | | | | | |
|--------|---------|-------|----|------|--------|---------|----|
| 31 | 30 | 29 | 28 | 27 | 26 | 25 | 24 |
| – | – | – | – | – | – | – | – |
| 23 | 22 | 21 | 20 | 19 | 18 | 17 | 16 |
| – | – | – | – | LDRB | | LDRA | |
| 15 | 14 | 13 | 12 | 11 | 10 | 9 | 8 |
| WAVE | CPCTRG | – | – | – | ABETRG | ETRGEDG | |
| 7 | 6 | 5 | 4 | 3 | 2 | 1 | 0 |
| LDBDIS | LDBSTOP | BURST | | CLKI | TCCLKS | | |

• TCCLKS: Clock Selection

| Value | | | Clock Selected |
|-------|---|---|----------------|
| 0 | 0 | 0 | TIMER_CLOCK1 |
| 0 | 0 | 1 | TIMER_CLOCK2 |
| 0 | 1 | 0 | TIMER_CLOCK3 |
| 0 | 1 | 1 | TIMER_CLOCK4 |
| 1 | 0 | 0 | TIMER_CLOCK5 |
| 1 | 0 | 1 | XC0 |
| 1 | 1 | 0 | XC1 |
| 1 | 1 | 1 | XC2 |

• CLKI: Clock Invert

0: Counter is incremented on rising edge of the clock.

1: Counter is incremented on falling edge of the clock.

• BURST: Burst Signal Selection

| Value | Description |
|-------|---|
| 0 0 | The clock is not gated by an external signal. |
| 0 1 | XC0 is ANDed with the selected clock. |
| 1 0 | XC1 is ANDed with the selected clock. |
| 1 1 | XC2 is ANDed with the selected clock. |

• LDBSTOP: Counter Clock Stopped with RB Loading

0: Counter clock is not stopped when RB loading occurs.

1: Counter clock is stopped when RB loading occurs.

• LDBDIS: Counter Clock Disable with RB Loading

0: Counter clock is not disabled when RB loading occurs.

1: Counter clock is disabled when RB loading occurs.

- **ETRGDGD: External Trigger Edge Selection**

| Value | | Edge |
|-------|---|--------------|
| 0 | 0 | none |
| 0 | 1 | rising edge |
| 1 | 0 | falling edge |
| 1 | 1 | each edge |

- **ABETRG: TIOA or TIOB External Trigger Selection**

0: TIOB is used as an external trigger.

1: TIOA is used as an external trigger.

- **CPCTRG: RC Compare Trigger Enable**

0: RC Compare has no effect on the counter and its clock.

1: RC Compare resets the counter and starts the counter clock.

- **WAVE**

0: Capture Mode is enabled.

1: Capture Mode is disabled (Waveform Mode is enabled).

- **LDRA: RA Loading Selection**

| Value | | Edge |
|-------|---|----------------------|
| 0 | 0 | none |
| 0 | 1 | rising edge of TIOA |
| 1 | 0 | falling edge of TIOA |
| 1 | 1 | each edge of TIOA |

- **LDRB: RB Loading Selection**

| Value | | Edge |
|-------|---|----------------------|
| 0 | 0 | none |
| 0 | 1 | rising edge of TIOA |
| 1 | 0 | falling edge of TIOA |
| 1 | 1 | each edge of TIOA |

33.7.5 TC Channel Mode Register: Waveform Mode

Name: TC_CMRx [x=0..2] (WAVE = 1)

Address: 0xFFFA0004 (0)[0], 0xFFFA0044 (0)[1], 0xFFFA0084 (0)[2]

Access: Read/Write

| | | | | | | | |
|--------|---------|-------|--------|------|--------|---------|----|
| 31 | 30 | 29 | 28 | 27 | 26 | 25 | 24 |
| BSWTRG | | BEEVT | | BCPC | | BCPB | |
| 23 | 22 | 21 | 20 | 19 | 18 | 17 | 16 |
| ASWTRG | | AEEVT | | ACPC | | ACPA | |
| 15 | 14 | 13 | 12 | 11 | 10 | 9 | 8 |
| WAVE | WAVSEL | | ENETRГ | EEVT | | EEVTEDG | |
| 7 | 6 | 5 | 4 | 3 | 2 | 1 | 0 |
| CPCDIS | CPCSTOP | BURST | | CLKI | TCCLKS | | |

• TCCLKS: Clock Selection

| TCCLKS | | | Clock Selected |
|--------|---|---|----------------|
| 0 | 0 | 0 | TIMER_CLOCK1 |
| 0 | 0 | 1 | TIMER_CLOCK2 |
| 0 | 1 | 0 | TIMER_CLOCK3 |
| 0 | 1 | 1 | TIMER_CLOCK4 |
| 1 | 0 | 0 | TIMER_CLOCK5 |
| 1 | 0 | 1 | XC0 |
| 1 | 1 | 0 | XC1 |
| 1 | 1 | 1 | XC2 |

• CLKI: Clock Invert

0: Counter is incremented on rising edge of the clock.

1: Counter is incremented on falling edge of the clock.

• BURST: Burst Signal Selection

| Value | Description |
|-------|---|
| 0 0 | The clock is not gated by an external signal. |
| 0 1 | XC0 is ANDed with the selected clock. |
| 1 0 | XC1 is ANDed with the selected clock. |
| 1 1 | XC2 is ANDed with the selected clock. |

• CPCSTOP: Counter Clock Stopped with RC Compare

0: Counter clock is not stopped when counter reaches RC.

1: Counter clock is stopped when counter reaches RC.

• CPCDIS: Counter Clock Disable with RC Compare

0: Counter clock is not disabled when counter reaches RC.

1: Counter clock is disabled when counter reaches RC.

- **EEVTEDG: External Event Edge Selection**

| Value | | Edge |
|-------|---|--------------|
| 0 | 0 | none |
| 0 | 1 | rising edge |
| 1 | 0 | falling edge |
| 1 | 1 | each edge |

- **EEVT: External Event Selection**

| Value | | Signal selected as external event | TIOB Direction |
|-------|---|-----------------------------------|----------------------|
| 0 | 0 | TIOB | input ⁽¹⁾ |
| 0 | 1 | XC0 | output |
| 1 | 0 | XC1 | output |
| 1 | 1 | XC2 | output |

Note: 1. If TIOB is chosen as the external event signal, it is configured as an input and no longer generates waveforms and subsequently no IRQs.

- **ENETR: External Event Trigger Enable**

0: The external event has no effect on the counter and its clock. In this case, the selected external event only controls the TIOA output.

1: The external event resets the counter and starts the counter clock.

- **WAVSEL: Waveform Selection**

| Value | | Effect |
|-------|---|---|
| 0 | 0 | UP mode without automatic trigger on RC Compare |
| 1 | 0 | UP mode with automatic trigger on RC Compare |
| 0 | 1 | UPDOWN mode without automatic trigger on RC Compare |
| 1 | 1 | UPDOWN mode with automatic trigger on RC Compare |

- **WAVE**

0: Waveform Mode is disabled (Capture Mode is enabled).

1: Waveform Mode is enabled.

- **ACPA: RA Compare Effect on TIOA**

| Value | | Effect |
|-------|---|--------|
| 0 | 0 | none |
| 0 | 1 | set |
| 1 | 0 | clear |
| 1 | 1 | toggle |

- **ACPC: RC Compare Effect on TIOA**

| Value | | Effect |
|-------|---|--------|
| 0 | 0 | none |
| 0 | 1 | set |
| 1 | 0 | clear |
| 1 | 1 | toggle |

- **AAEVT: External Event Effect on TIOA**

| Value | | Effect |
|-------|---|--------|
| 0 | 0 | none |
| 0 | 1 | set |
| 1 | 0 | clear |
| 1 | 1 | toggle |

- **ASWTRG: Software Trigger Effect on TIOA**

| Value | | Effect |
|-------|---|--------|
| 0 | 0 | none |
| 0 | 1 | set |
| 1 | 0 | clear |
| 1 | 1 | toggle |

- **BCPB: RB Compare Effect on TIOB**

| Value | | Effect |
|-------|---|--------|
| 0 | 0 | none |
| 0 | 1 | set |
| 1 | 0 | clear |
| 1 | 1 | toggle |

- **BCPC: RC Compare Effect on TIOB**

| Value | | Effect |
|-------|---|--------|
| 0 | 0 | none |
| 0 | 1 | set |
| 1 | 0 | clear |
| 1 | 1 | toggle |

- **BEEVT: External Event Effect on TIOB**

| Value | | Effect |
|-------|---|--------|
| 0 | 0 | none |
| 0 | 1 | set |
| 1 | 0 | clear |
| 1 | 1 | toggle |

- **BSWTRG: Software Trigger Effect on TIOB**

| Value | | Effect |
|-------|---|--------|
| 0 | 0 | none |
| 0 | 1 | set |
| 1 | 0 | clear |
| 1 | 1 | toggle |

33.7.6 TC Counter Value Register

Name: TC_CVx [x=0..2]

Address: 0xFFFA0010 (0)[0], 0xFFFA0050 (0)[1], 0xFFFA0090 (0)[2]

Access: Read-only

| | | | | | | | |
|----|----|----|----|----|----|----|----|
| 31 | 30 | 29 | 28 | 27 | 26 | 25 | 24 |
| – | – | – | – | – | – | – | – |
| 23 | 22 | 21 | 20 | 19 | 18 | 17 | 16 |
| – | – | – | – | – | – | – | – |
| 15 | 14 | 13 | 12 | 11 | 10 | 9 | 8 |
| CV | | | | | | | |
| 7 | 6 | 5 | 4 | 3 | 2 | 1 | 0 |
| CV | | | | | | | |

- **CV: Counter Value**

CV contains the counter value in real time.

33.7.7 TC Register A

Name: TC_RAx [x=0..2]

Address: 0xFFFA0014 (0)[0], 0xFFFA0054 (0)[1], 0xFFFA0094 (0)[2]

Access: Read-only if WAVE = 0, Read/Write if WAVE = 1

| | | | | | | | |
|----|----|----|----|----|----|----|----|
| 31 | 30 | 29 | 28 | 27 | 26 | 25 | 24 |
| – | – | – | – | – | – | – | – |
| 23 | 22 | 21 | 20 | 19 | 18 | 17 | 16 |
| – | – | – | – | – | – | – | – |
| 15 | 14 | 13 | 12 | 11 | 10 | 9 | 8 |
| RA | | | | | | | |
| 7 | 6 | 5 | 4 | 3 | 2 | 1 | 0 |
| RA | | | | | | | |

- **RA: Register A**

RA contains the Register A value in real time.

33.7.8 TC Register B

Name: TC_RBx [x=0..2]

Address: 0xFFFA0018 (0)[0], 0xFFFA0058 (0)[1], 0xFFFA0098 (0)[2]

Access: Read-only if WAVE = 0, Read/Write if WAVE = 1

| | | | | | | | |
|----|----|----|----|----|----|----|----|
| 31 | 30 | 29 | 28 | 27 | 26 | 25 | 24 |
| – | – | – | – | – | – | – | – |
| 23 | 22 | 21 | 20 | 19 | 18 | 17 | 16 |
| – | – | – | – | – | – | – | – |
| 15 | 14 | 13 | 12 | 11 | 10 | 9 | 8 |
| RB | | | | | | | |
| 7 | 6 | 5 | 4 | 3 | 2 | 1 | 0 |
| RB | | | | | | | |

- **RB: Register B**

RB contains the Register B value in real time.

33.7.9 TC Register C

Name: TC_RCx [x=0..2]

Address: 0xFFFA001C (0)[0], 0xFFFA005C (0)[1], 0xFFFA009C (0)[2]

Access: Read/Write

| | | | | | | | |
|----|----|----|----|----|----|----|----|
| 31 | 30 | 29 | 28 | 27 | 26 | 25 | 24 |
| – | – | – | – | – | – | – | – |
| 23 | 22 | 21 | 20 | 19 | 18 | 17 | 16 |
| – | – | – | – | – | – | – | – |
| 15 | 14 | 13 | 12 | 11 | 10 | 9 | 8 |
| RC | | | | | | | |
| 7 | 6 | 5 | 4 | 3 | 2 | 1 | 0 |
| RC | | | | | | | |

- **RC: Register C**

RC contains the Register C value in real time.

33.7.10 TC Status Register

Name: TC_SRx [x=0..2]

Address: 0xFFFFA0020 (0)[0], 0xFFFFA0060 (0)[1], 0xFFFFA00A0 (0)[2]

Access: Read-only

| | | | | | | | |
|-------|-------|-------|------|------|-------|-------|--------|
| 31 | 30 | 29 | 28 | 27 | 26 | 25 | 24 |
| – | – | – | – | – | – | – | – |
| 23 | 22 | 21 | 20 | 19 | 18 | 17 | 16 |
| – | – | – | – | – | MTIOB | MTIOA | CLKSTA |
| 15 | 14 | 13 | 12 | 11 | 10 | 9 | 8 |
| – | – | – | – | – | – | – | – |
| 7 | 6 | 5 | 4 | 3 | 2 | 1 | 0 |
| ETRGS | LDRBS | LDRAS | CPCS | CPBS | CPAS | LOVRS | COVFS |

- **COVFS: Counter Overflow Status**

0: No counter overflow has occurred since the last read of the Status Register.

1: A counter overflow has occurred since the last read of the Status Register.

- **LOVRS: Load Overrun Status**

0: Load overrun has not occurred since the last read of the Status Register or WAVE = 1.

1: RA or RB have been loaded at least twice without any read of the corresponding register since the last read of the Status Register, if WAVE = 0.

- **CPAS: RA Compare Status**

0: RA Compare has not occurred since the last read of the Status Register or WAVE = 0.

1: RA Compare has occurred since the last read of the Status Register, if WAVE = 1.

- **CPBS: RB Compare Status**

0: RB Compare has not occurred since the last read of the Status Register or WAVE = 0.

1: RB Compare has occurred since the last read of the Status Register, if WAVE = 1.

- **CPCS: RC Compare Status**

0: RC Compare has not occurred since the last read of the Status Register.

1: RC Compare has occurred since the last read of the Status Register.

- **LDRAS: RA Loading Status**

0: RA Load has not occurred since the last read of the Status Register or WAVE = 1.

1: RA Load has occurred since the last read of the Status Register, if WAVE = 0.

- **LDRBS: RB Loading Status**

0: RB Load has not occurred since the last read of the Status Register or WAVE = 1.

1: RB Load has occurred since the last read of the Status Register, if WAVE = 0.

- **ETRGS: External Trigger Status**

0: External trigger has not occurred since the last read of the Status Register.

1: External trigger has occurred since the last read of the Status Register.

- **CLKSTA: Clock Enabling Status**

0: Clock is disabled.

1: Clock is enabled.

- **MTIOA: TIOA Mirror**

0: TIOA is low. If WAVE = 0, this means that TIOA pin is low. If WAVE = 1, this means that TIOA is driven low.

1: TIOA is high. If WAVE = 0, this means that TIOA pin is high. If WAVE = 1, this means that TIOA is driven high.

- **MTIOB: TIOB Mirror**

0: TIOB is low. If WAVE = 0, this means that TIOB pin is low. If WAVE = 1, this means that TIOB is driven low.

1: TIOB is high. If WAVE = 0, this means that TIOB pin is high. If WAVE = 1, this means that TIOB is driven high.

33.7.11 TC Interrupt Enable Register

Name: TC_IERx [x=0..2]

Address: 0xFFFFA0024 (0)[0], 0xFFFFA0064 (0)[1], 0xFFFFA00A4 (0)[2]

Access: Write-only

| | | | | | | | |
|-------|-------|-------|------|------|------|-------|-------|
| 31 | 30 | 29 | 28 | 27 | 26 | 25 | 24 |
| – | – | – | – | – | – | – | – |
| 23 | 22 | 21 | 20 | 19 | 18 | 17 | 16 |
| – | – | – | – | – | – | – | – |
| 15 | 14 | 13 | 12 | 11 | 10 | 9 | 8 |
| – | – | – | – | – | – | – | – |
| 7 | 6 | 5 | 4 | 3 | 2 | 1 | 0 |
| ETRGS | LDRBS | LDRAS | CPCS | CPBS | CPAS | LOVRS | COVFS |

- **COVFS: Counter Overflow**

0: No effect.

1: Enables the Counter Overflow Interrupt.

- **LOVRS: Load Overrun**

0: No effect.

1: Enables the Load Overrun Interrupt.

- **CPAS: RA Compare**

0: No effect.

1: Enables the RA Compare Interrupt.

- **CPBS: RB Compare**

0: No effect.

1: Enables the RB Compare Interrupt.

- **CPCS: RC Compare**

0: No effect.

1: Enables the RC Compare Interrupt.

- **LDRAS: RA Loading**

0: No effect.

1: Enables the RA Load Interrupt.

- **LDRBS: RB Loading**

0: No effect.

1: Enables the RB Load Interrupt.

- **ETRGS: External Trigger**

0: No effect.

1: Enables the External Trigger Interrupt.

33.7.12 TC Interrupt Disable Register

Name: TC_IDRx [x=0..2]

Address: 0xFFFA0028 (0)[0], 0xFFFA0068 (0)[1], 0xFFFA00A8 (0)[2]

Access: Write-only

| | | | | | | | |
|-------|-------|-------|------|------|------|-------|-------|
| 31 | 30 | 29 | 28 | 27 | 26 | 25 | 24 |
| – | – | – | – | – | – | – | – |
| 23 | 22 | 21 | 20 | 19 | 18 | 17 | 16 |
| – | – | – | – | – | – | – | – |
| 15 | 14 | 13 | 12 | 11 | 10 | 9 | 8 |
| – | – | – | – | – | – | – | – |
| 7 | 6 | 5 | 4 | 3 | 2 | 1 | 0 |
| ETRGS | LDRBS | LDRAS | CPCS | CPBS | CPAS | LOVRS | COVFS |

- **COVFS: Counter Overflow**

0: No effect.

1: Disables the Counter Overflow Interrupt.

- **LOVRS: Load Overrun**

0: No effect.

1: Disables the Load Overrun Interrupt (if WAVE = 0).

- **CPAS: RA Compare**

0: No effect.

1: Disables the RA Compare Interrupt (if WAVE = 1).

- **CPBS: RB Compare**

0: No effect.

1: Disables the RB Compare Interrupt (if WAVE = 1).

- **CPCS: RC Compare**

0: No effect.

1: Disables the RC Compare Interrupt.

- **LDRAS: RA Loading**

0: No effect.

1: Disables the RA Load Interrupt (if WAVE = 0).

- **LDRBS: RB Loading**

0: No effect.

1: Disables the RB Load Interrupt (if WAVE = 0).

- **ETRGS: External Trigger**

0: No effect.

1: Disables the External Trigger Interrupt.

33.7.13 TC Interrupt Mask Register

Name: TC_IMRx [x=0..2]

Address: 0xFFFA002C (0)[0], 0xFFFA006C (0)[1], 0xFFFA00AC (0)[2]

Access: Read-only

| | | | | | | | |
|-------|-------|-------|------|------|------|-------|-------|
| 31 | 30 | 29 | 28 | 27 | 26 | 25 | 24 |
| – | – | – | – | – | – | – | – |
| 23 | 22 | 21 | 20 | 19 | 18 | 17 | 16 |
| – | – | – | – | – | – | – | – |
| 15 | 14 | 13 | 12 | 11 | 10 | 9 | 8 |
| – | – | – | – | – | – | – | – |
| 7 | 6 | 5 | 4 | 3 | 2 | 1 | 0 |
| ETRGS | LDRBS | LDRAS | CPCS | CPBS | CPAS | LOVRS | COVFS |

- **COVFS: Counter Overflow**

0: The Counter Overflow Interrupt is disabled.

1: The Counter Overflow Interrupt is enabled.

- **LOVRS: Load Overrun**

0: The Load Overrun Interrupt is disabled.

1: The Load Overrun Interrupt is enabled.

- **CPAS: RA Compare**

0: The RA Compare Interrupt is disabled.

1: The RA Compare Interrupt is enabled.

- **CPBS: RB Compare**

0: The RB Compare Interrupt is disabled.

1: The RB Compare Interrupt is enabled.

- **CPCS: RC Compare**

0: The RC Compare Interrupt is disabled.

1: The RC Compare Interrupt is enabled.

- **LDRAS: RA Loading**

0: The Load RA Interrupt is disabled.

1: The Load RA Interrupt is enabled.

- **LDRBS: RB Loading**

0: The Load RB Interrupt is disabled.

1: The Load RB Interrupt is enabled.

- **ETRGS: External Trigger**

0: The External Trigger Interrupt is disabled.

1: The External Trigger Interrupt is enabled.

34. MultiMedia Card Interface (MCI)

34.1 Overview

The MultiMedia Card Interface (MCI) supports the MultiMedia Card (MMC) Specification V2.2 and the SD Memory Card Specification V1.0.

The MCI includes a command register, response registers, data registers, timeout counters and error detection logic that automatically handle the transmission of commands and, when required, the reception of the associated responses and data with a limited processor overhead.

The MCI supports stream, block and multi-block data read and write, and is compatible with the Peripheral DMA Controller (PDC) channels, minimizing processor intervention for large buffer transfers.

The MCI operates at a rate of up to Master Clock divided by 2 and supports the interfacing of 2 slot(s). Each slot may be used to interface with a MultiMediaCard bus (up to 30 Cards) or with a SD Memory Card. Only one slot can be selected at a time (slots are multiplexed). A bit field in the SD Card Register performs this selection.

The SD Memory Card communication is based on a 9-pin interface (clock, command, four data and three power lines) and the MultiMedia Card on a 7-pin interface (clock, command, one data, three power lines and one reserved for future use).

The SD Memory Card interface also supports MultiMedia Card operations. The main differences between SD and MultiMedia Cards are the initialization process and the bus topology.

34.2 Embedded Characteristics

- Compatibility with MultiMedia Card Specification Version 2.2
- Compatibility with SD Memory Card Specification Version 1.0
- Cards clock rate up to Master Clock divided by 2
- Embedded power management to slow down clock rate when not used
- Each MCI has two slots, each supporting
 - One slot for one MultiMedia Card Bus (up to 30 cards) or
 - One SD Memory Card
- Support for stream, block and multi-block data read and write
- Supports connection to Peripheral DMA Controller (PDC)
 - . Minimizes processor intervention for large buffer transfers

34.3 Block Diagram

Figure 34-1. Block Diagram

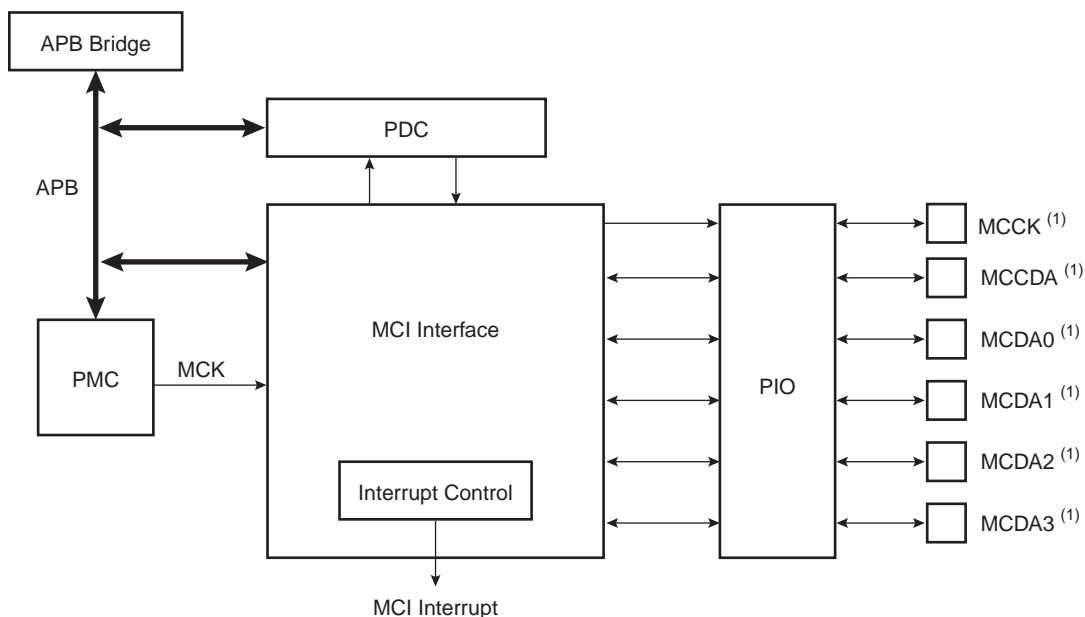

Note: 1. When several MCI (x MCI) are embedded in a product, MCCK refers to MCIx_CK, MCCDA to MCIx_CDA, MCDAy to MCIx_DAy.

34.4 Application Block Diagram

Figure 34-2. Application Block Diagram

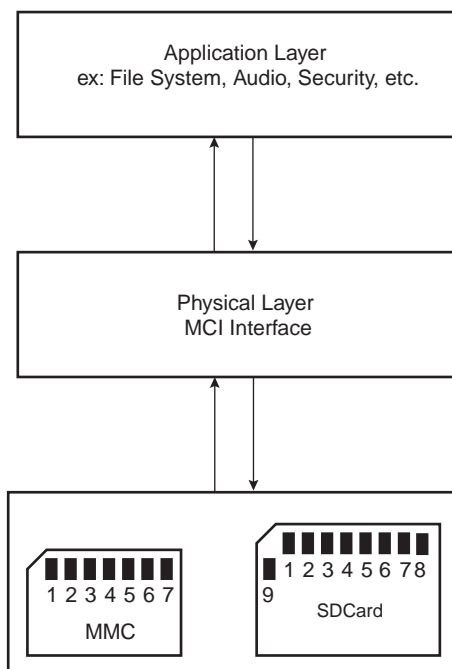

34.5 Pin Name List

Table 34-1. I/O Lines Description

| Pin Name ⁽²⁾ | Pin Description | Type ⁽¹⁾ | Comments |
|-------------------------|---------------------|---------------------|---|
| MCCDA | Command/response | I/O/PP/OD | CMD of an MMC or SDCard |
| MCCK | Clock | I/O | CLK of an MMC or SD Card |
| MCDA0–MCDA3 | Data 0..3 of Slot A | I/O/PP | DAT0 of an MMC DAT[0..3] of an SD Card |

Notes: 1. I: Input, O: Output, PP: Push/Pull, OD: Open Drain.

2. When several MCI (x MCI) are embedded in a product, MCCK refers to MCIx_CK, MCCDA to MCIx_CDA, MCDAy to MCIx_DAy.

34.6 Product Dependencies

34.6.1 I/O Lines

The pins used for interfacing the MultiMedia Cards or SD Cards may be multiplexed with PIO lines. The programmer must first program the PIO controllers to assign the peripheral functions to MCI pins.

34.6.2 Power Management

The MCI may be clocked through the Power Management Controller (PMC), so the programmer must first configure the PMC to enable the MCI clock.

34.6.3 Interrupt

The MCI interface has an interrupt line connected to the Advanced Interrupt Controller (AIC).

Handling the MCI interrupt requires programming the AIC before configuring the MCI.

34.7 Bus Topology

Figure 34-3. Multimedia Memory Card Bus Topology



The MultiMedia Card communication is based on a 7-pin serial bus interface. It has three communication lines and four supply lines.

Table 34-2. Bus Topology

| Pin Number | Name | Type ⁽¹⁾ | Description | MCI Pin Name ⁽²⁾ (Slot z) |
|------------|--------|---------------------|-----------------------|---|
| 1 | RSV | NC | Not connected | - |
| 2 | CMD | I/O/PP/OD | Command/response | MCCDz |
| 3 | VSS1 | S | Supply voltage ground | VSS |
| 4 | VDD | S | Supply voltage | VDD |
| 5 | CLK | I/O | Clock | MCKK |
| 6 | VSS2 | S | Supply voltage ground | VSS |
| 7 | DAT[0] | I/O/PP | Data 0 | MCDz0 |

Notes: 1. I: Input, O: Output, PP: Push/Pull, OD: Open Drain.
2. When several MCI (x MCI) are embedded in a product, MCKK refers to MCIx_CK, MCCDA to MCIx_CDA, MCDAY to MCIx_DAY.

Figure 34-4. MMC Bus Connections (One Slot)

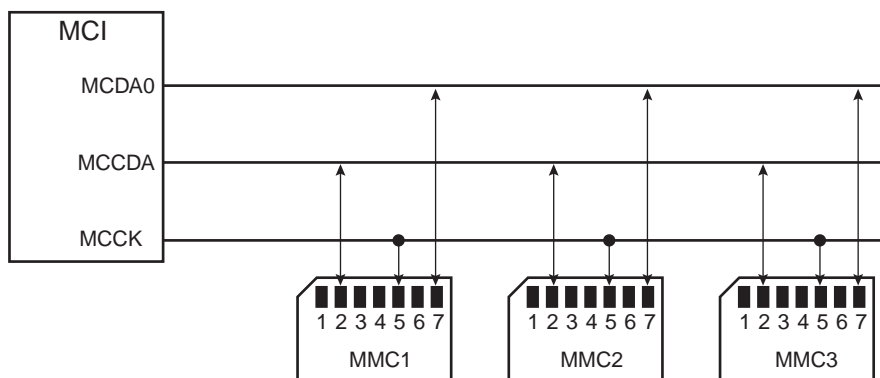

Note: When several MCI (x MCI) are embedded in a product, MCKK refers to MCIx_CK, MCCDA to MCIx_CDA, MCDAY to MCIx_DAY.

Figure 34-5. SD Memory Card Bus Topology

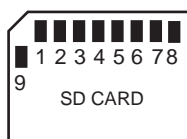

The SD Memory Card bus includes the signals listed in [Table 34-3](#).

Table 34-3. SD Memory Card Bus Signals

| Pin Number | Name | Type ⁽¹⁾ | Description | MCI Pin Name ⁽²⁾ (Slot z) |
|------------|-----------|---------------------|------------------------------|---|
| 1 | CD/DAT[3] | I/O/PP | Card detect/ Data line Bit 3 | MCDz3 |
| 2 | CMD | PP | Command/response | MCCDz |
| 3 | VSS1 | S | Supply voltage ground | VSS |
| 4 | VDD | S | Supply voltage | VDD |
| 5 | CLK | I/O | Clock | MCCK |
| 6 | VSS2 | S | Supply voltage ground | VSS |
| 7 | DAT[0] | I/O/PP | Data line Bit 0 | MCDz0 |
| 8 | DAT[1] | I/O/PP | Data line Bit 1 | MCDz1 |
| 9 | DAT[2] | I/O/PP | Data line Bit 2 | MCDz2 |

Notes: 1. I: input, O: output, PP: Push Pull, OD: Open Drain.
 2. When several MCI (x MCI) are embedded in a product, MCCK refers to MCIx_CK, MCCDA to MCIx_CDA, MCDAY to MCIx_DAY.

Figure 34-6. SD Card Bus Connections with One Slot

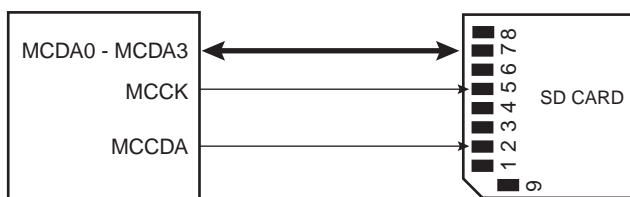

Note: When several MCI (x MCI) are embedded in a product, MCCK refers to MCIx_CK, MCCDA to MCIx_CDA, MCDAY to MCIx_DAY.

When the MCI is configured to operate with SD memory cards, the width of the data bus can be selected in the MCI_SDCR. Clearing the SDCBUS bit in this register means that the width is one bit; setting it means that the width is four bits. In the case of multimedia cards, only the data line 0 is used. The other data lines can be used as independent PIOs.

34.8 MultiMedia Card Operations

After a power-on reset, the cards are initialized by a special message-based MultiMedia Card bus protocol. Each message is represented by one of the following tokens:

- **Command:** A command is a token that starts an operation. A command is sent from the host either to a single card (addressed command) or to all connected cards (broadcast command). A command is transferred serially on the CMD line.
- **Response:** A response is a token which is sent from an addressed card or (synchronously) from all connected cards to the host as an answer to a previously received command. A response is transferred serially on the CMD line.
- **Data:** Data can be transferred from the card to the host or vice versa. Data is transferred via the data line.

Card addressing is implemented using a session address assigned during the initialization phase by the bus controller to all currently connected cards. Their unique CID number identifies individual cards.

The structure of commands, responses and data blocks is described in the MultiMedia-Card System Specification. See also [Table 34-4 on page 552](#).

MultiMediaCard bus data transfers are composed of these tokens.

There are different types of operations. Addressed operations always contain a command and a response token. In addition, some operations have a data token; the others transfer their information directly within the command or response structure. In this case, no data token is present in an operation. The bits on the DAT and the CMD lines are transferred synchronous to the clock MCI Clock.

Two types of data transfer commands are defined:

- Sequential commands: These commands initiate a continuous data stream. They are terminated only when a stop command follows on the CMD line. This mode reduces the command overhead to an absolute minimum.
- Block-oriented commands: These commands send a data block succeeded by CRC bits.

Both read and write operations allow either single or multiple block transmission. A multiple block transmission is terminated when a stop command follows on the CMD line similarly to the sequential read.

The MCI provides a set of registers to perform the entire range of MultiMedia Card operations.

34.8.1 Command - Response Operation

After reset, the MCI is disabled and becomes valid after setting the MCIEN bit in the Control Register (MCI_CR).

The PWSEN bit saves power by dividing the MCI clock by $2^{PWSDIV} + 1$ when the bus is inactive.

The command and the response of the card are clocked out with the rising edge of the MCI Clock.

All the timings for MultiMedia Card are defined in the MultiMediaCard System Specification.

The two bus modes (open drain and push/pull) needed to process all the operations are defined in the MCI Command Register (MCI_CMDR). The MCI_CMDR allows a command to be carried out.

For example, to perform an ALL_SEND_CID command:

| CMD | Host Command | | | | | N _{ID} Cycles | | | Response | | | High Impedance State | | |
|-----|--------------|---|---------|-----|---|------------------------|-------|---|----------|---|---------|----------------------|---|---|
| | S | T | Content | CRC | E | Z | ***** | Z | S | T | Content | Z | Z | Z |
| | | | | | | | | | | | | | | |

The command ALL_SEND_CID and the fields and values for the MCI_CMDR are described in [Table 34-4](#) and [Table 34-5](#).

Table 34-4. ALL_SEND_CID Command Description

| CMD Index | Type | Argument | Response | Abbreviation | Command Description |
|-----------|------|-------------------|----------|--------------|--|
| CMD2 | bcr | [31:0] stuff bits | R2 | ALL_SEND_CID | Asks all cards to send their CID numbers on the CMD line |

Note: bcr means broadcast command with response.

Table 34-5. Fields and Values for MCI_CMDR

| Field | Value |
|--|--|
| CMDNB (command number) | 2 (CMD2) |
| RSPTYP (response type) | 2 (R2: 136 bits response) |
| SPCMD (special command) | 0 (not a special command) |
| OPCMD (open drain command) | 1 |
| MAXLAT (max latency for command to response) | 0 (NID cycles ==> 5 cycles) |
| TRCMD (transfer command) | 0 (No transfer) |
| TRDIR (transfer direction) | X (available only in transfer command) |
| TRTYP (transfer type) | X (available only in transfer command) |

The argument register (MCI_ARGR) contains the argument field of the command.

To send a command, the user must perform the following steps:

- Fill MCI_ARGR with the command argument.
- Set MCI_CMDR (see [Table 34-5](#)).

The command is sent immediately after writing the command register. The status bit CMDRDY in the Status Register (MCI_SR) is asserted when the command is completed.

While the card maintains a busy indication (at the end of a STOP_TRANSMISSION command CMD12, for example), a new command shall not be sent. The NOTBUSY flag in the status register (MCI_SR) is asserted when the card releases the busy indication.

If the command requires a response, it can be read in the MCI Response Register (MCI_RSPR). The response size can be from 48 bits up to 136 bits depending on the command. The MCI embeds an error detection to prevent any corrupted data during the transfer.

The following flowchart shows how to send a command to the card and read the response if needed. In this example, the status register bits are polled but setting the appropriate bits in the Interrupt Enable Register (MCI_IER) allows using an interrupt method.

Figure 34-7. Command/Response Functional Flow Diagram

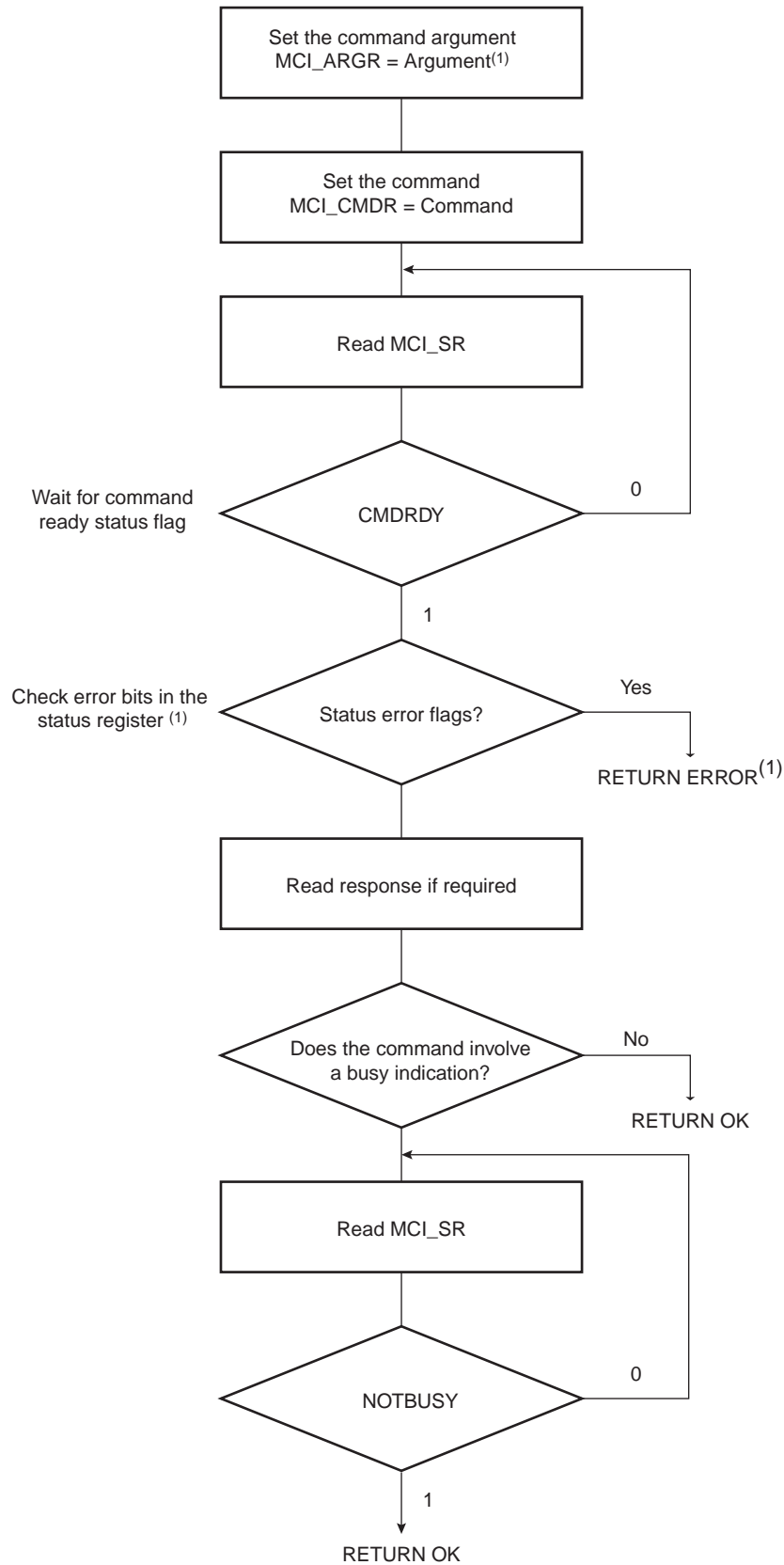

Note: If the command is SEND_OP_COND, the CRC error flag is always present (refer to R3 response in the MultiMedia Card specification).

34.8.2 Data Transfer Operation

The MultiMedia Card allows several read/write operations (single block, multiple blocks, stream, etc.). These kind of transfers can be selected setting the Transfer Type (TRTYP) field in the MCI_CMDR.

These operations can be done using the features of the Peripheral DMA Controller (PDC). If the PDCMODE bit is set in MCI_MR, then all reads and writes use the PDC facilities.

In all cases, the block length (BLKLEN field) must be defined in the mode register MCI_MR. This field determines the size of the data block.

34.8.3 Read Operation

The following flowchart shows how to read a single block with or without use of PDC facilities. In this example (see [Figure 34-8](#)), a polling method is used to wait for the end of read. Similarly, the user can configure the Interrupt Enable Register (MCI_IER) to trigger an interrupt at the end of read.

Figure 34-8. Read Functional Flow Diagram

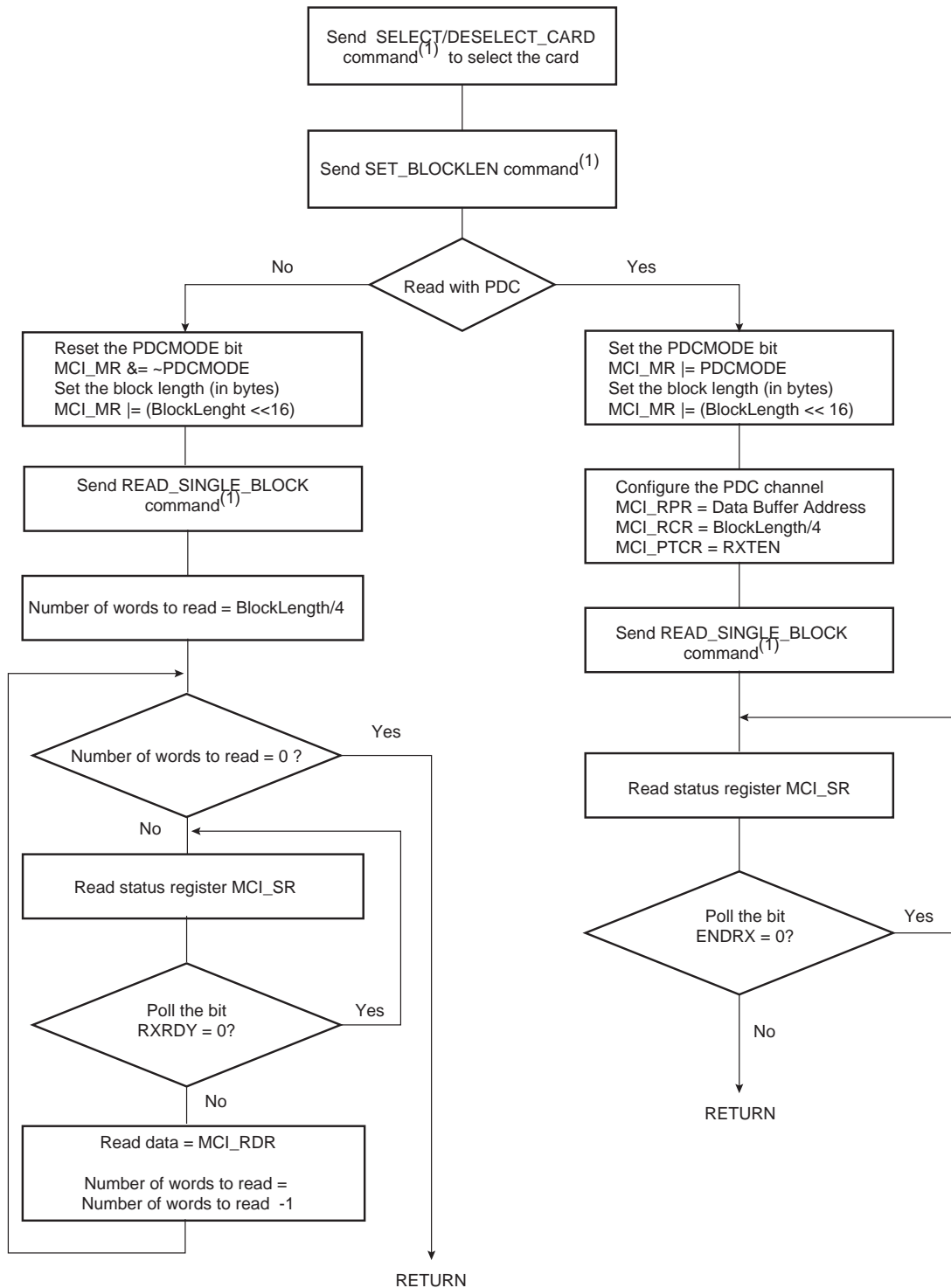

Note: It is assumed that this command has been correctly sent (see [Figure 34-7](#)).

34.8.4 Write Operation

In write operation, the MCI Mode Register (MCI_MR) is used to define the padding value when writing non-multiple block size. If the bit PDCPADV is 0, then 0x00 value is used when padding data, otherwise 0xFF is used.

If set, the bit PDCMODE enables PDC transfer.

The following flowchart shows how to write a single block with or without use of PDC facilities (see [Figure 34-9](#)). Polling or interrupt method can be used to wait for the end of write according to the contents of the Interrupt Mask Register (MCI_IMR).

Figure 34-9. Write Functional Flow Diagram

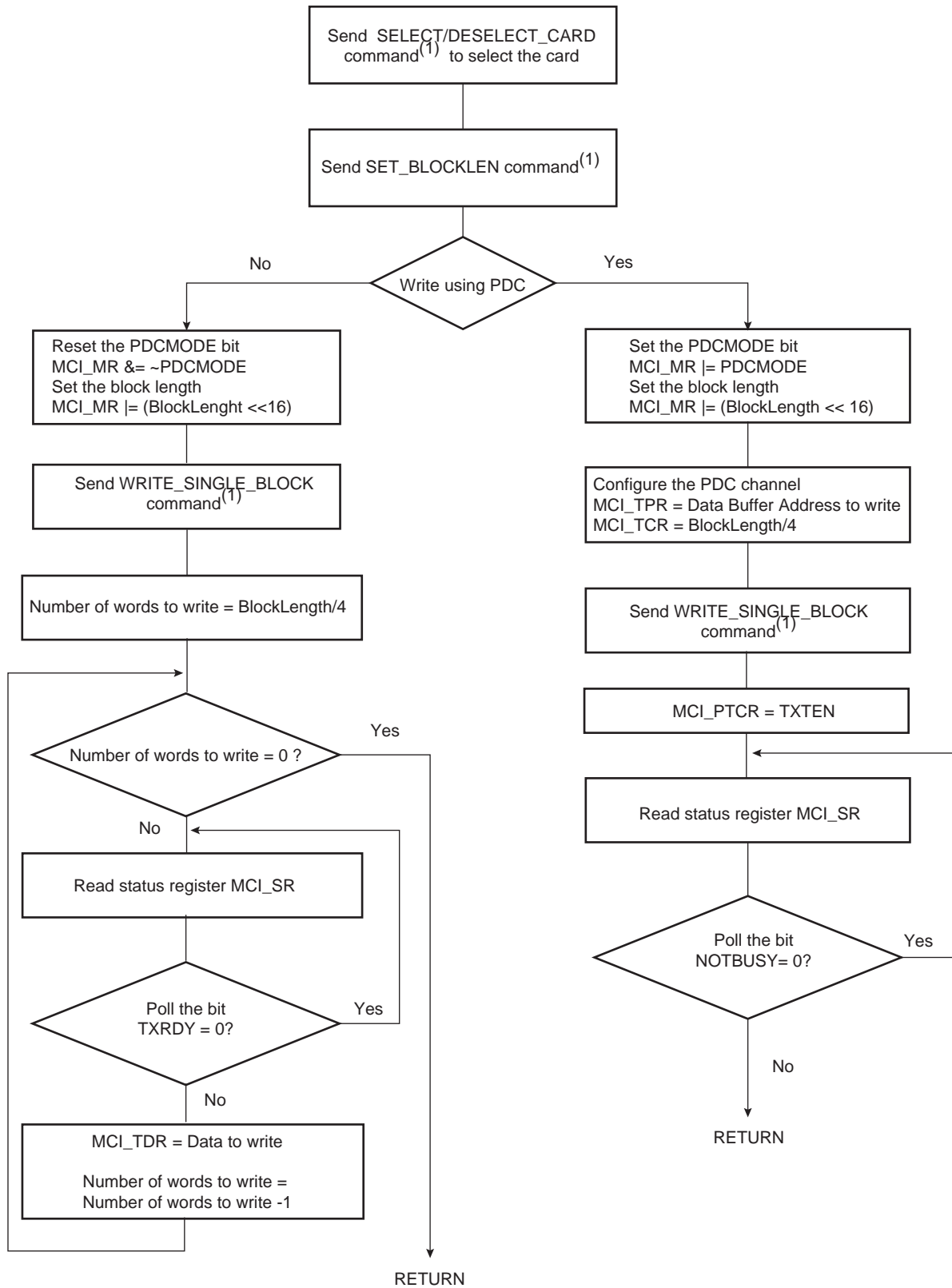

Note: It is assumed that this command has been correctly sent (see Figure 34-7).

The following flowchart shows how to manage a multiple write block transfer with the PDC (see [Figure 34-10](#)). Polling or interrupt method can be used to wait for the end of write according to the contents of the Interrupt Mask Register (MCI_IMR).

Figure 34-10. Multiple Write Functional Flow Diagram

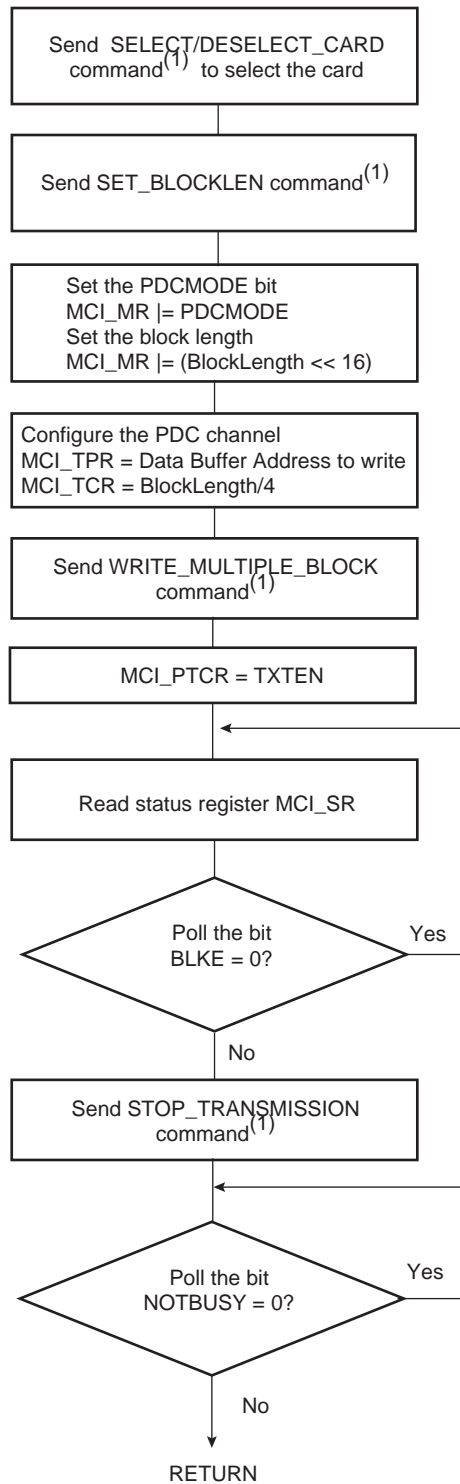

Note: It is assumed that this command has been correctly sent (see [Figure 34-7](#)).

34.9 SD Card Operations

The MultiMedia Card Interface allows processing of SD Memory (Secure Digital Memory Card) Card commands. SD cards are based on the Multi Media Card (MMC) format, but are physically slightly thicker and feature higher data transfer rates, a lock switch on the side to prevent accidental overwriting and security features. The physical form factor, pin assignment and data transfer protocol are forward-compatible with the MultiMedia Card with some additions. SD is covered by numerous patents and trademarks, and licensing is only available through the Secure Digital Card Association.

The SD Card communication is based on a 9-pin interface (Clock, Command, 4 x Data and 3 x Power lines). The communication protocol is defined as a part of this specification. The main difference between the SD Card and the MultiMedia Card is the initialization process.

The SD Card Register (MCI_SDCR) allows selection of the Card Slot and the data bus width.

The SD Card bus allows dynamic configuration of the number of data lines. After power up, by default, the SD Card uses only DAT0 for data transfer. After initialization, the host can change the bus width (number of active data lines).

34.10 MultiMedia Card Interface (MCI) User Interface

Table 34-6. Register Mapping

| Offset | Register | Register Name | Access | Reset |
|-------------|----------------------------------|---------------|------------|--------|
| 0x00 | Control Register | MCI_CR | Write-only | – |
| 0x04 | Mode Register | MCI_MR | Read/Write | 0x0 |
| 0x08 | Data Timeout Register | MCI_DTOR | Read/Write | 0x0 |
| 0x0C | SD Card Register | MCI_SDCR | Read/Write | 0x0 |
| 0x10 | Argument Register | MCI_ARGR | Read/Write | 0x0 |
| 0x14 | Command Register | MCI_CMDR | Write-only | – |
| 0x18–0x1C | Reserved | – | – | – |
| 0x20 | Response Register ⁽¹⁾ | MCI_RSPR | Read-only | 0x0 |
| 0x24 | Response Register ⁽¹⁾ | MCI_RSPR | Read-only | 0x0 |
| 0x28 | Response Register ⁽¹⁾ | MCI_RSPR | Read-only | 0x0 |
| 0x2C | Response Register ⁽¹⁾ | MCI_RSPR | Read-only | 0x0 |
| 0x30 | Receive Data Register | MCI_RDR | Read-only | 0x0 |
| 0x34 | Transmit Data Register | MCI_TDR | Write-only | – |
| 0x38–0x3C | Reserved | – | – | – |
| 0x40 | Status Register | MCI_SR | Read-only | 0xC0E5 |
| 0x44 | Interrupt Enable Register | MCI_IER | Write-only | – |
| 0x48 | Interrupt Disable Register | MCI_IDR | Write-only | – |
| 0x4C | Interrupt Mask Register | MCI_IMR | Read-only | 0x0 |
| 0x50–0xFC | Reserved | – | – | – |
| 0x100–0x124 | Reserved for the PDC | – | – | – |

Note: 1. The response register can be read by N accesses at the same MCI_RSPR or at consecutive addresses (0x20 to 0x2C). N depends on the size of the response.

34.10.1 MCI Control Register

Name: MCI_CR
Address: 0xFFFFA8000
Access: Write-only

| | | | | | | | |
|-------|----|----|----|--------|-------|--------|-------|
| 31 | 30 | 29 | 28 | 27 | 26 | 25 | 24 |
| – | – | – | – | – | – | – | – |
| 23 | 22 | 21 | 20 | 19 | 18 | 17 | 16 |
| – | – | – | – | – | – | – | – |
| 15 | 14 | 13 | 12 | 11 | 10 | 9 | 8 |
| – | – | – | – | – | – | – | – |
| 7 | 6 | 5 | 4 | 3 | 2 | 1 | 0 |
| SWRST | – | – | – | PWSDIS | PWSEN | MCIDIS | MCIEN |

- **MCIEN: Multi-Media Interface Enable**

0: No effect.

1: Enables the Multi-Media Interface if MCDIS is 0.

- **MCIDIS: Multi-Media Interface Disable**

0: No effect.

1: Disables the Multi-Media Interface.

- **PWSEN: Power Save Mode Enable**

0: No effect.

1: Enables the Power Saving Mode if PWSDIS is 0.

Warning: Before enabling this mode, the user must set a value different from 0 in the PWSDIV field (Mode Register MCI_MR).

- **PWSDIS: Power Save Mode Disable**

0: No effect.

1: Disables the Power Saving Mode.

- **SWRST: Software Reset**

0: No effect.

1: Resets the MCI. A software triggered hardware reset of the MCI interface is performed.

34.10.2 MCI Mode Register

Name: MCI_MR

Address: 0xFFFFA8004

Access: Read/write

| | | | | | | | |
|---------|---------|--------|----|----|--------|----|----|
| 31 | 30 | 29 | 28 | 27 | 26 | 25 | 24 |
| – | – | BLKLEN | | | | | |
| 23 | 22 | 21 | 20 | 19 | 18 | 17 | 16 |
| BLKLEN | | | | | | 0 | 0 |
| 15 | 14 | 13 | 12 | 11 | 10 | 9 | 8 |
| PDCMODE | PDCPADV | – | – | – | PWSDIV | | |
| 7 | 6 | 5 | 4 | 3 | 2 | 1 | 0 |
| CLKDIV | | | | | | | |

- **CLKDIV: Clock Divider**

Multimedia Card Interface clock (MCCK or MCI_CK) is Master Clock (MCK) divided by $(2^{*}(\text{CLKDIV}+1))$.

- **PWSDIV: Power Saving Divider**

Multimedia Card Interface clock is divided by $2^{(\text{PWSDIV})} + 1$ when entering Power Saving Mode.

Warning: This value must be different from 0 before enabling the Power Save Mode in the MCI_CR (MCI_PWSEN bit).

- **PDCPADV: PDC Padding Value**

0: 0x00 value is used when padding data in write transfer (not only PDC transfer).

1: 0xFF value is used when padding data in write transfer (not only PDC transfer).

- **PDCMODE: PDC-oriented Mode**

0: Disables PDC transfer

1: Enables PDC transfer. In this case, UNRE and OVRE flags in the MCI Mode Register (MCI_SR) are deactivated after the PDC transfer has been completed.

- **BLKLEN: Data Block Length**

This field determines the size of the data block.

Bits 16 and 17 must be set to 0

34.10.3 MCI Data Timeout Register

Name: MCI_DTOR
Address: 0xFFFFA8008
Access: Read/write

| | | | | | | | |
|----|--------|----|----|-------|----|----|----|
| 31 | 30 | 29 | 28 | 27 | 26 | 25 | 24 |
| – | – | – | – | – | – | – | – |
| 23 | 22 | 21 | 20 | 19 | 18 | 17 | 16 |
| – | – | – | – | – | – | – | – |
| 15 | 14 | 13 | 12 | 11 | 10 | 9 | 8 |
| – | – | – | – | – | – | – | – |
| 7 | 6 | 5 | 4 | 3 | 2 | 1 | 0 |
| – | DTOMUL | | | DTCYC | | | |

- **DTCYC: Data Timeout Cycle Number**

Defines a number of Master Clock cycles with DTOMUL.

- **DTOMUL: Data Timeout Multiplier**

These fields determine the maximum number of Master Clock cycles that the MCI waits between two data block transfers. It equals (DTCYC x Multiplier).

Multiplier is defined by DTOMUL as shown in the following table:

| Value | | | Multiplier |
|-------|---|---|------------|
| 0 | 0 | 0 | 1 |
| 0 | 0 | 1 | 16 |
| 0 | 1 | 0 | 128 |
| 0 | 1 | 1 | 256 |
| 1 | 0 | 0 | 1024 |
| 1 | 0 | 1 | 4096 |
| 1 | 1 | 0 | 65536 |
| 1 | 1 | 1 | 1048576 |

If the data time-out set by DTCYC and DTOMUL has been exceeded, the Data Time-out Error flag (DTCYC) in the MCI Status Register (MCI_SR) raises.

34.10.4 MCI SDCard Register

Name: MCI_SDCR

Address: 0xFFFFA800C

Access: Read/write

| | | | | | | | |
|--------|----|----|----|----|----|--------|----|
| 31 | 30 | 29 | 28 | 27 | 26 | 25 | 24 |
| – | – | – | – | – | – | – | – |
| 23 | 22 | 21 | 20 | 19 | 18 | 17 | 16 |
| – | – | – | – | – | – | – | – |
| 15 | 14 | 13 | 12 | 11 | 10 | 9 | 8 |
| – | – | – | – | – | – | – | – |
| 7 | 6 | 5 | 4 | 3 | 2 | 1 | 0 |
| SDCBUS | – | – | – | – | – | SDCSEL | |

• SDCSEL: SDCard Slot

| Value | SDCard Slot |
|-------|---------------------|
| 0 0 | Slot A is selected. |
| 0 1 | Reserved |
| 1 0 | Reserved |
| 1 1 | Reserved |

• SDCBUS: SDCard Bus Width

0: 1-bit data bus

1: 4-bit data bus

34.10.5 MCI Argument Register

Name: MCI_ARGR

Address: 0xFFFFA8010

Access: Read/write

| | | | | | | | |
|-----|----|----|----|----|----|----|----|
| 31 | 30 | 29 | 28 | 27 | 26 | 25 | 24 |
| ARG | | | | | | | |
| 23 | 22 | 21 | 20 | 19 | 18 | 17 | 16 |
| ARG | | | | | | | |
| 15 | 14 | 13 | 12 | 11 | 10 | 9 | 8 |
| ARG | | | | | | | |
| 7 | 6 | 5 | 4 | 3 | 2 | 1 | 0 |
| ARG | | | | | | | |

- **ARG: Command Argument**

34.10.6 MCI Command Register

Name: MCI_CMDR
Address: 0xFFFFA8014
Access: Write-only

| | | | | | | | |
|--------|----|----|--------|--------|-------|-------|----|
| 31 | 30 | 29 | 28 | 27 | 26 | 25 | 24 |
| – | – | – | – | – | – | – | – |
| 23 | 22 | 21 | 20 | 19 | 18 | 17 | 16 |
| – | – | – | TRTYP | | TRDIR | TRCMD | |
| 15 | 14 | 13 | 12 | 11 | 10 | 9 | 8 |
| – | – | – | MAXLAT | OPDCMD | SPCMD | | |
| 7 | 6 | 5 | 4 | 3 | 2 | 1 | 0 |
| RSPTYP | | | CMDNB | | | | |

This register is write-protected while CMDRDY is 0 in MCI_SR. If an Interrupt command is sent, this register is only writeable by an interrupt response (field SPCMD). This means that the current command execution cannot be interrupted or modified.

- **CMDNB: Command Number**

MultiMedia Card bus command numbers are defined in the MultiMedia Card specification.

- **RSPTYP: Response Type**

| Value | Response Type |
|-------|-------------------|
| 0 0 | No response. |
| 0 1 | 48-bit response. |
| 1 0 | 136-bit response. |
| 1 1 | Reserved. |

- **SPCMD: Special Command**

| Value | Command |
|-------|--|
| 0 0 0 | Not a special CMD. |
| 0 0 1 | Initialization CMD: 74 clock cycles for initialization sequence. |
| 0 1 0 | Synchronized CMD: Wait for the end of the current data block transfer before sending the pending command. |
| 0 1 1 | Reserved. |
| 1 0 0 | Interrupt command: Corresponds to the Interrupt Mode (CMD40). |
| 1 0 1 | Interrupt response: Corresponds to the Interrupt Mode (CMD40). |

- **OPDCMD: Open Drain Command**

0: Push pull command

1: Open drain command

- **MAXLAT: Max Latency for Command to Response**

0: 5-cycle max latency

1: 64-cycle max latency

- **TRCMD: Transfer Command**

| Value | | Transfer Type |
|-------|---|---------------------|
| 0 | 0 | No data transfer |
| 0 | 1 | Start data transfer |
| 1 | 0 | Stop data transfer |
| 1 | 1 | Reserved |

- **TRDIR: Transfer Direction**

0: Write

1: Read

- **TRTYP: Transfer Type**

| Value | | | Transfer Type |
|-------|---|---|---------------------------|
| 0 | 0 | 0 | MMC/SDCard Single Block |
| 0 | 0 | 1 | MMC/SDCard Multiple Block |
| 0 | 1 | 0 | MMC Stream |
| 0 | 1 | 1 | Reserved |

34.10.7 MCI Response Register

Name: MCI_RSPR

Address: 0xFFFFA8020

Access: Read-only



- **RSP: Response**

Note: The response register can be read by N accesses at the same MCI_RSPR or at consecutive addresses (0x20 to 0x2C). N depends on the size of the response.

34.10.8 MCI Receive Data Register

Name: MCI_RDR

Address: 0xFFFFA8030

Access: Read-only

| | | | | | | | |
|------|----|----|----|----|----|----|----|
| 31 | 30 | 29 | 28 | 27 | 26 | 25 | 24 |
| DATA | | | | | | | |
| 23 | 22 | 21 | 20 | 19 | 18 | 17 | 16 |
| DATA | | | | | | | |
| 15 | 14 | 13 | 12 | 11 | 10 | 9 | 8 |
| DATA | | | | | | | |
| 7 | 6 | 5 | 4 | 3 | 2 | 1 | 0 |
| DATA | | | | | | | |

- **DATA:** Data to Read

34.10.9 MCI Transmit Data Register

Name: MCI_TDR

Address: 0xFFFFA8034

Access: Write-only

| | | | | | | | |
|------|----|----|----|----|----|----|----|
| 31 | 30 | 29 | 28 | 27 | 26 | 25 | 24 |
| DATA | | | | | | | |
| 23 | 22 | 21 | 20 | 19 | 18 | 17 | 16 |
| DATA | | | | | | | |
| 15 | 14 | 13 | 12 | 11 | 10 | 9 | 8 |
| DATA | | | | | | | |
| 7 | 6 | 5 | 4 | 3 | 2 | 1 | 0 |
| DATA | | | | | | | |

- **DATA:** Data to Write

34.10.10 MCI Status Register

Name: MCI_SR

Address: 0xFFFFA8040

Access: Read-only

| | | | | | | | |
|--------|--------|---------|------|-------|-------|-------|--------|
| 31 | 30 | 29 | 28 | 27 | 26 | 25 | 24 |
| UNRE | OVRE | – | – | – | – | – | – |
| 23 | 22 | 21 | 20 | 19 | 18 | 17 | 16 |
| – | DTOE | DCRCE | RTOE | RENDE | RRCCE | RDIR | RINDE |
| 15 | 14 | 13 | 12 | 11 | 10 | 9 | 8 |
| TXBUFE | RXBUFE | – | – | – | – | – | – |
| 7 | 6 | 5 | 4 | 3 | 2 | 1 | 0 |
| ENDTX | ENDRX | NOTBUSY | DTIP | BLKE | TXRDY | RXRDY | CMDRDY |

- **CMDRDY: Command Ready**

0: A command is in progress.

1: The last command has been sent. Cleared when writing in the MCI_CMDR.

- **RXRDY: Receiver Ready**

0: Data has not yet been received since the last read of MCI_RDR.

1: Data has been received since the last read of MCI_RDR.

- **TXRDY: Transmit Ready**

0= The last data written in MCI_TDR has not yet been transferred in the Shift Register.

1= The last data written in MCI_TDR has been transferred in the Shift Register.

- **BLKE: Data Block Ended**

This flag must be used only for Write Operations.

0: A data block transfer is not yet finished. Cleared when reading the MCI_SR.

1: A data block transfer has ended, including the CRC16 Status transmission.

In PDC mode (PDCMODE=1), the flag is set when the CRC Status of the last block has been transmitted (TXBUFE already set).

Otherwise (PDCMODE=0), the flag is set for each transmitted CRC Status.

Refer to the MMC or SD Specification for more details concerning the CRC Status.

- **DTIP: Data Transfer in Progress**

0: No data transfer in progress.

1: The current data transfer is still in progress, including CRC16 calculation. Cleared at the end of the CRC16 calculation.

- **NOTBUSY: MCI Not Busy**

This flag must be used only for Write Operations.

A block write operation uses a simple busy signalling of the write operation duration on the data (DAT0) line: during a data transfer block, if the card does not have a free data receive buffer, the card indicates this condition by pulling down the data line (DAT0) to LOW. The card stops pulling down the data line as soon as at least one receive buffer for the defined data transfer block length becomes free.

The NOTBUSY flag allows to deal with these different states.

0: The MCI is not ready for new data transfer. Cleared at the end of the card response.

1: The MCI is ready for new data transfer. Set when the busy state on the data line has ended. This corresponds to a free internal data receive buffer of the card.

Refer to the MMC or SD Specification for more details concerning the busy behavior.

- **ENDRX: End of RX Buffer**

0: The Receive Counter Register has not reached 0 since the last write in MCI_RCR or MCI_RNCR.

1: The Receive Counter Register has reached 0 since the last write in MCI_RCR or MCI_RNCR.

- **ENDTX: End of TX Buffer**

0: The Transmit Counter Register has not reached 0 since the last write in MCI_TCR or MCI_TNCR.

1: The Transmit Counter Register has reached 0 since the last write in MCI_TCR or MCI_TNCR.

Note: BLKE and NOTBUSY flags can be used to check that the data has been successfully transmitted on the data lines and not only transferred from the PDC to the MCI Controller.

- **RXBUFF: RX Buffer Full**

0: MCI_RCR or MCI_RNCR has a value other than 0.

1: Both MCI_RCR and MCI_RNCR have a value of 0.

- **TXBUFE: TX Buffer Empty**

0: MCI_TCR or MCI_TNCR has a value other than 0.

1: Both MCI_TCR and MCI_TNCR have a value of 0.

Note: BLKE and NOTBUSY flags can be used to check that the data has been successfully transmitted on the data lines and not only transferred from the PDC to the MCI Controller.

- **RINDE: Response Index Error**

0: No error.

1: A mismatch is detected between the command index sent and the response index received. Cleared when writing in the MCI_CMDR.

- **RDIRE: Response Direction Error**

0: No error.

1: The direction bit from card to host in the response has not been detected.

- **RCRCE: Response CRC Error**

0: No error.

1: A CRC7 error has been detected in the response. Cleared when writing in the MCI_CMDR.

- **RENDE: Response End Bit Error**

0: No error.

1: The end bit of the response has not been detected. Cleared when writing in the MCI_CMDR.

- **RTOE: Response Time-out Error**

0: No error.

1: The response time-out set by MAXLAT in the MCI_CMDR has been exceeded. Cleared when writing in the MCI_CMDR.

- **DCRCE: Data CRC Error**

0: No error.

1: A CRC16 error has been detected in the last data block. Cleared by reading in the MCI_SR.

- **DTOE: Data Time-out Error**

0: No error.

1: The data time-out set by DTOCYC and DTOMUL in MCI_DTOR has been exceeded. Cleared by reading in the MCI_SR.

- **OVRE: Overrun**

0: No error.

1: At least one 8-bit received data has been lost (not read). Cleared when sending a new data transfer command.

- **UNRE: Underrun**

0: No error.

1: At least one 8-bit data has been sent without valid information (not written). Cleared when sending a new data transfer command.

- **RXBUFF: RX Buffer Full**

0: MCI_RCR or MCI_RNCR has a value other than 0.

1: Both MCI_RCR and MCI_RNCR have a value of 0.

- **TXBUFE: TX Buffer Empty**

0: MCI_TCR or MCI_TNCR has a value other than 0.

1: Both MCI_TCR and MCI_TNCR have a value of 0.

34.10.11 MCI Interrupt Enable Register

Name: MCI_IER

Address: 0xFFFFA8044

Access: Write-only

| | | | | | | | |
|--------|--------|---------|------|-------|-------|-------|--------|
| 31 | 30 | 29 | 28 | 27 | 26 | 25 | 24 |
| UNRE | OVRE | – | – | – | – | – | – |
| 23 | 22 | 21 | 20 | 19 | 18 | 17 | 16 |
| – | DTOE | DCRCE | RTOE | RENDE | RCRCE | RDIRE | RINDE |
| 15 | 14 | 13 | 12 | 11 | 10 | 9 | 8 |
| TXBUFE | RXBUFF | – | – | – | – | – | – |
| 7 | 6 | 5 | 4 | 3 | 2 | 1 | 0 |
| ENDTX | ENDRX | NOTBUSY | DTIP | BLKE | TXRDY | RXRDY | CMDRDY |

- **CMDRDY:** Command Ready Interrupt Enable
- **RXRDY:** Receiver Ready Interrupt Enable
- **TXRDY:** Transmit Ready Interrupt Enable
- **BLKE:** Data Block Ended Interrupt Enable
- **DTIP:** Data Transfer in Progress Interrupt Enable
- **NOTBUSY:** Data Not Busy Interrupt Enable
- **ENDRX:** End of Receive Buffer Interrupt Enable
- **ENDTX:** End of Transmit Buffer Interrupt Enable
- **RXBUFF:** Receive Buffer Full Interrupt Enable
- **TXBUFE:** Transmit Buffer Empty Interrupt Enable
- **RINDE:** Response Index Error Interrupt Enable
- **RDIRE:** Response Direction Error Interrupt Enable
- **RCRCE:** Response CRC Error Interrupt Enable
- **RENDE:** Response End Bit Error Interrupt Enable
- **RTOE:** Response Time-out Error Interrupt Enable
- **DCRCE:** Data CRC Error Interrupt Enable
- **DTOE:** Data Time-out Error Interrupt Enable
- **OVRE:** Overrun Interrupt Enable

- **UNRE: UnderRun Interrupt Enable**

0: No effect.

1: Enables the corresponding interrupt.

34.10.12 MCI Interrupt Disable Register

Name: MCI_IDR

Address: 0xFFFFA8048

Access: Write-only

| | | | | | | | |
|--------|--------|---------|------|-------|-------|-------|--------|
| 31 | 30 | 29 | 28 | 27 | 26 | 25 | 24 |
| UNRE | OVRE | – | – | – | – | – | – |
| 23 | 22 | 21 | 20 | 19 | 18 | 17 | 16 |
| – | DTOE | DCRCE | RTOE | RENDE | RCRCE | RDIRE | RINDE |
| 15 | 14 | 13 | 12 | 11 | 10 | 9 | 8 |
| TXBUFE | RXBUFF | – | – | – | – | – | – |
| 7 | 6 | 5 | 4 | 3 | 2 | 1 | 0 |
| ENDTX | ENDRX | NOTBUSY | DTIP | BLKE | TXRDY | RXRDY | CMDRDY |

- **CMDRDY:** Command Ready Interrupt Disable
- **RXRDY:** Receiver Ready Interrupt Disable
- **TXRDY:** Transmit Ready Interrupt Disable
- **BLKE:** Data Block Ended Interrupt Disable
- **DTIP:** Data Transfer in Progress Interrupt Disable
- **NOTBUSY:** Data Not Busy Interrupt Disable
- **ENDRX:** End of Receive Buffer Interrupt Disable
- **ENDTX:** End of Transmit Buffer Interrupt Disable
- **RXBUFF:** Receive Buffer Full Interrupt Disable
- **TXBUFE:** Transmit Buffer Empty Interrupt Disable
- **RINDE:** Response Index Error Interrupt Disable
- **RDIRE:** Response Direction Error Interrupt Disable
- **RCRCE:** Response CRC Error Interrupt Disable
- **RENDE:** Response End Bit Error Interrupt Disable
- **RTOE:** Response Time-out Error Interrupt Disable
- **DCRCE:** Data CRC Error Interrupt Disable
- **DTOE:** Data Time-out Error Interrupt Disable
- **OVRE:** Overrun Interrupt Disable

- **UNRE: UnderRun Interrupt Disable**

0: No effect.

1: Disables the corresponding interrupt.

34.10.13 MCI Interrupt Mask Register

Name: MCI_IMR
Address: 0xFFFFA804C
Access: Read-only

| | | | | | | | |
|--------|--------|---------|------|-------|-------|-------|--------|
| 31 | 30 | 29 | 28 | 27 | 26 | 25 | 24 |
| UNRE | OVRE | – | – | – | – | – | – |
| 23 | 22 | 21 | 20 | 19 | 18 | 17 | 16 |
| – | DTOE | DCRCE | RTOE | RENDE | RCRCE | RDIRE | RINDE |
| 15 | 14 | 13 | 12 | 11 | 10 | 9 | 8 |
| TXBUFE | RXBUFF | – | – | – | – | – | – |
| 7 | 6 | 5 | 4 | 3 | 2 | 1 | 0 |
| ENDTX | ENDRX | NOTBUSY | DTIP | BLKE | TXRDY | RXRDY | CMDRDY |

- **CMDRDY:** Command Ready Interrupt Mask
- **RXRDY:** Receiver Ready Interrupt Mask
- **TXRDY:** Transmit Ready Interrupt Mask
- **BLKE:** Data Block Ended Interrupt Mask
- **DTIP:** Data Transfer in Progress Interrupt Mask
- **NOTBUSY:** Data Not Busy Interrupt Mask
- **ENDRX:** End of Receive Buffer Interrupt Mask
- **ENDTX:** End of Transmit Buffer Interrupt Mask
- **RXBUFF:** Receive Buffer Full Interrupt Mask
- **TXBUFE:** Transmit Buffer Empty Interrupt Mask
- **RINDE:** Response Index Error Interrupt Mask
- **RDIRE:** Response Direction Error Interrupt Mask
- **RCRCE:** Response CRC Error Interrupt Mask
- **RENDE:** Response End Bit Error Interrupt Mask
- **RTOE:** Response Time-out Error Interrupt Mask
- **DCRCE:** Data CRC Error Interrupt Mask
- **DTOE:** Data Time-out Error Interrupt Mask
- **OVRE:** Overrun Interrupt Mask

- **UNRE: UnderRun Interrupt Mask**

0: The corresponding interrupt is not enabled.

1: The corresponding interrupt is enabled.

35. USB Host Port (UHP)

35.1 Overview

The USB Host Port (UHP) interfaces the USB with the host application. It handles Open HCI protocol (Open Host Controller Interface) as well as USB v2.0 Full-speed and Low-speed protocols.

The USB Host Port integrates a root hub and transceivers on downstream ports. It provides several high-speed half-duplex serial communication ports at a baud rate of 12 Mbit/s. Up to 127 USB devices (printer, camera, mouse, keyboard, disk, etc.) and the USB hub can be connected to the USB host in the USB “tiered star” topology.

The USB Host Port controller is fully compliant with the Open HCI specification. The USB Host Port User Interface (registers description) can be found in the Open HCI Rev 1.0 Specification available on www.hp.com. The standard OHCI USB stack driver can be easily ported to ATMEL’s architecture in the same way all existing class drivers run without hardware specialization.

This means that all standard class devices are automatically detected and available to the user application. As an example, integrating an HID (Human Interface Device) class driver provides a plug & play feature for all USB keyboards and mice.

35.2 Embedded Characteristics

- Compliance with Open HCI Rev 1.0 specification
- Compliance with USB V2.0 Full-speed and Low-speed Specification
- Supports both Low-speed 1.5 Mbit/s and Full-speed 12 Mbit/s USB devices
- Root hub integrated with two downstream USB ports
- Two embedded USB transceivers
- No overcurrent detection
- Supports power management
- Operates as a master on the Bus Matrix

35.3 Block Diagram

Figure 35-1. Block Diagram

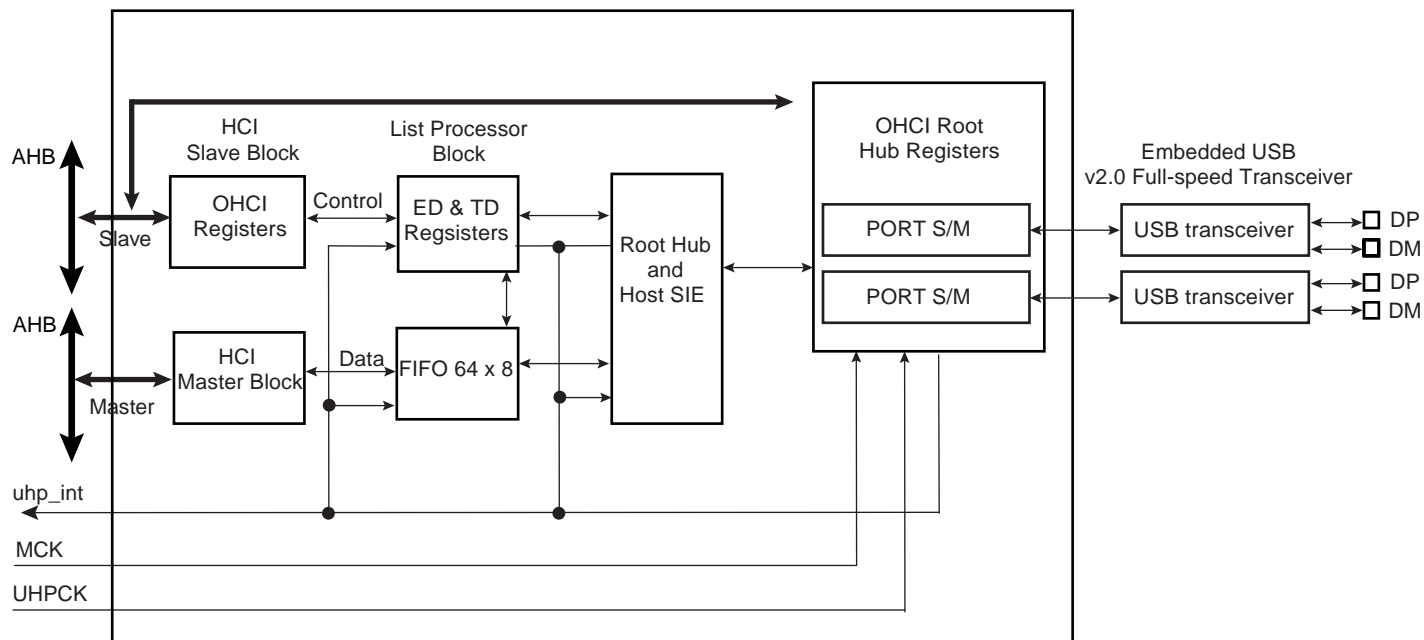

Access to the USB host operational registers is achieved through the AHB bus slave interface. The OpenHCI host controller initializes master DMA transfers through the ASB bus master interface as follows:

- Fetches endpoint descriptors and transfer descriptors
- Access to endpoint data from system memory
- Access to the HC communication area
- Write status and retire transfer Descriptor

Memory access errors (abort, misalignment) lead to an “Unrecoverable Error” indicated by the corresponding flag in the host controller operational registers.

The USB root hub is integrated in the USB host. Several USB downstream ports are available. The number of downstream ports can be determined by the software driver reading the root hub’s operational registers. Device connection is automatically detected by the USB host port logic.

Warning: A pull-down must be connected to DP on the board. Otherwise the USB host will permanently detect a device connection on this port.

USB physical transceivers are integrated in the product and driven by the root hub’s ports.

Over current protection on ports can be activated by the USB host controller. Atmel’s standard product does not dedicate pads to external over current protection.

35.4 Product Dependencies

35.4.1 I/O Lines

DPs and DMs are not controlled by any PIO controllers. The embedded USB physical transceivers are controlled by the USB host controller.

35.4.2 Power Management

The USB host controller requires a 48 MHz clock. This clock must be generated by a PLL with a correct accuracy of $\pm 0.25\%$.

Thus the USB device peripheral receives two clocks from the Power Management Controller (PMC): the master clock MCK used to drive the peripheral user interface (MCK domain) and the UHPCLK 48 MHz clock used to interface with the bus USB signals (Recovered 12 MHz domain).

35.4.3 Interrupt

The USB host interface has an interrupt line connected to the Advanced Interrupt Controller (AIC).

Handling USB host interrupts requires programming the AIC before configuring the UHP.

35.5 Functional Description

Please refer to the Open Host Controller Interface Specification for USB Release 1.0.a.

35.5.1 Host Controller Interface

There are two communication channels between the Host Controller and the Host Controller Driver. The first channel uses a set of operational registers located on the USB Host Controller. The Host Controller is the target for all communications on this channel. The operational registers contain control, status and list pointer registers. They are mapped in the memory mapped area. Within the operational register set there is a pointer to a location in the processor address space named the Host Controller Communication Area (HCCA). The HCCA is the second communication channel. The host controller is the master for all communication on this channel. The HCCA contains the head pointers to the interrupt Endpoint Descriptor lists, the head pointer to the done queue and status information associated with start-of-frame processing.

The basic building blocks for communication across the interface are Endpoint Descriptors (ED, 4 double words) and Transfer Descriptors (TD, 4 or 8 double words). The host controller assigns an Endpoint Descriptor to each endpoint in the system. A queue of Transfer Descriptors is linked to the Endpoint Descriptor for the specific endpoint.

Figure 35-2. USB Host Communication Channels

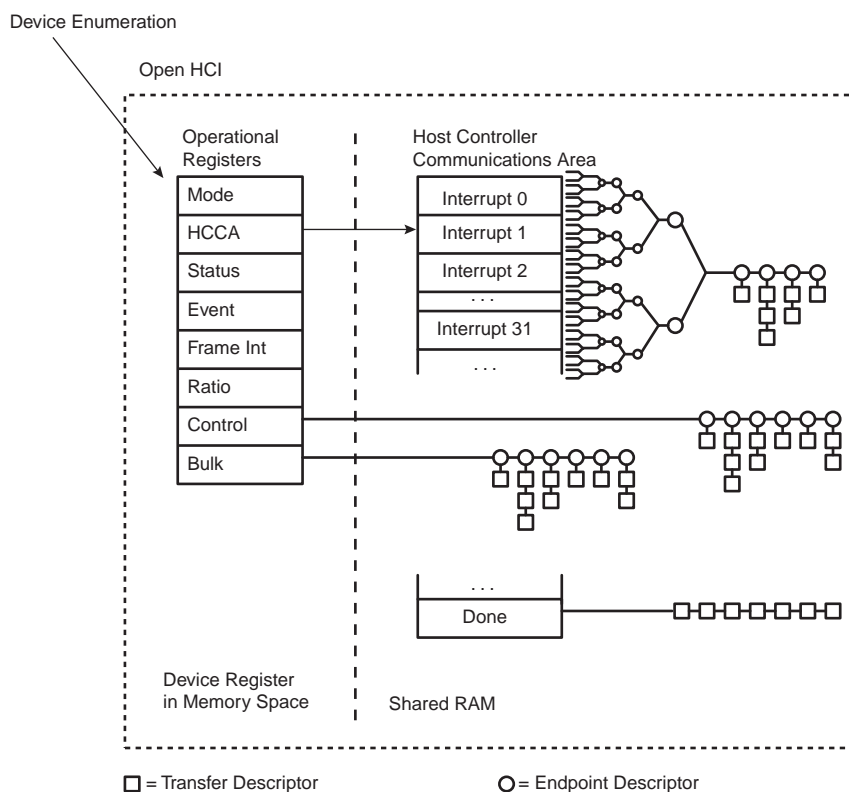

35.5.2 Host Controller Driver

Figure 35-3. USB Host Drivers

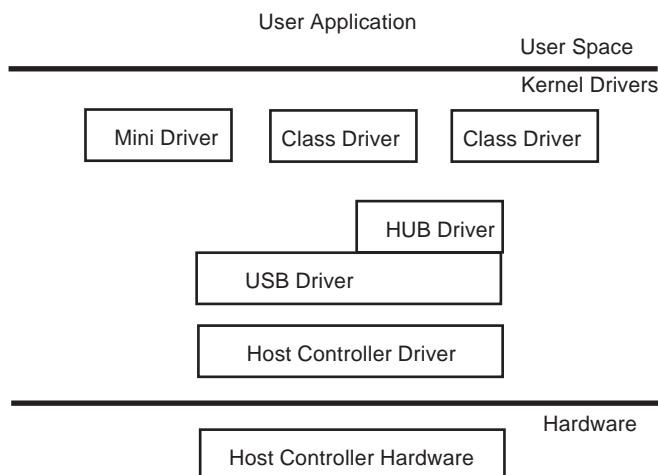

USB Handling is done through several layers as follows:

- Host controller hardware and serial engine: Transmits and receives USB data on the bus.
- Host controller driver: Drives the Host controller hardware and handles the USB protocol.
- USB Bus driver and hub driver: Handles USB commands and enumeration. Offers a hardware independent interface.
- Mini driver: Handles device specific commands.
- Class driver: Handles standard devices. This acts as a generic driver for a class of devices, for example the HID driver.

35.6 Typical Connection

Figure 35-4. Board Schematic to Interface UHP Device Controller

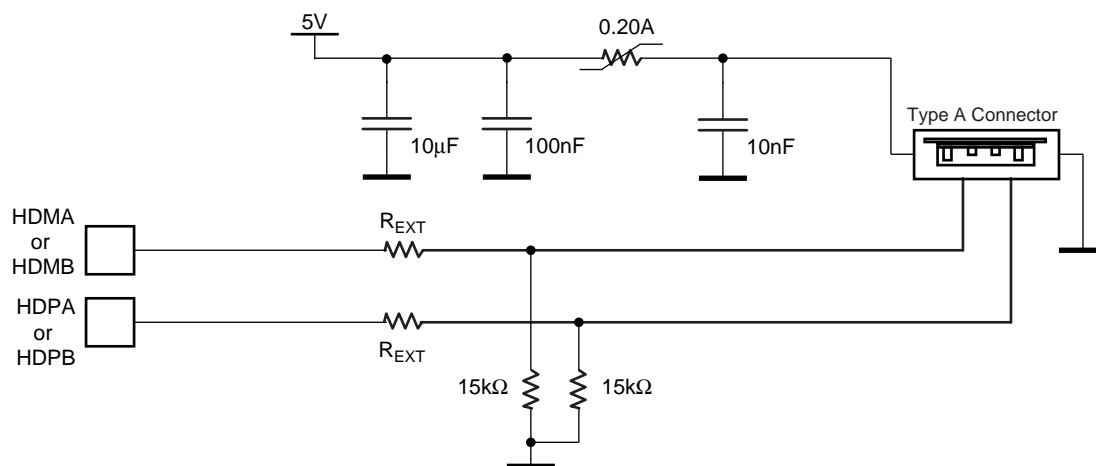

As device connection is automatically detected by the USB host port logic, a pull-down must be connected on DP and DM on the board. Otherwise the USB host permanently detects a device connection on this port.

A termination serial resistor must be connected to HDP and HDM. The resistor value is defined in the electrical specification of the product (R_{EXT}).

36. USB Device Port (UDP)

36.1 Overview

The USB Device Port (UDP) is compliant with the Universal Serial Bus (USB) V2.0 full-speed device specification. Each endpoint can be configured in one of several USB transfer types. It can be associated with one or two banks of a dual-port RAM used to store the current data payload. If two banks are used, one DPR bank is read or written by the processor, while the other is read or written by the USB device peripheral. This feature is mandatory for isochronous endpoints. Thus the device maintains the maximum bandwidth (1M bytes/s) by working with endpoints with two banks of DPR.

Table 36-1. USB Endpoint Description

| Endpoint Number | Mnemonic | Dual-Bank ⁽¹⁾ | Max. Endpoint Size | Endpoint Type |
|-----------------|----------|--------------------------|--------------------|------------------------|
| 0 | EP0 | No | 8 | Control/Bulk/Interrupt |
| 1 | EP1 | Yes | 64 | Bulk/Iso/Interrupt |
| 2 | EP2 | Yes | 64 | Bulk/Iso/Interrupt |
| 3 | EP3 | No | 64 | Control/Bulk/Interrupt |
| 4 | EP4 | Yes | 256 | Bulk/Iso/Interrupt |
| 5 | EP5 | Yes | 256 | Bulk/Iso/Interrupt |

Note: 1. The Dual-Bank function provides two banks for an endpoint. This feature is used for ping-pong mode.

Suspend and resume are automatically detected by the USB device, which notifies the processor by raising an interrupt. Depending on the product, an external signal can be used to send a wakeup to the USB host controller.

36.2 Embedded Characteristics

- USB V2.0 Full-speed Compliant, 12 Mbits per Second
- Embedded USB V2.0 Full-speed Transceiver
- 6 Endpoints
- Embedded Dual-port RAM for Endpoints
- Suspend/Resume Logic
- Ping-pong Mode (2 Memory Banks) for Isochronous and Bulk Endpoints
- Compatible with Embedded ARM7TDMI® and ARM9TDMI® Processor
- Can be Directly Connected to the Atmel Implementation of the AMBA Peripheral Bus (APB)

36.3 Block Diagram

Figure 36-1. Block Diagram

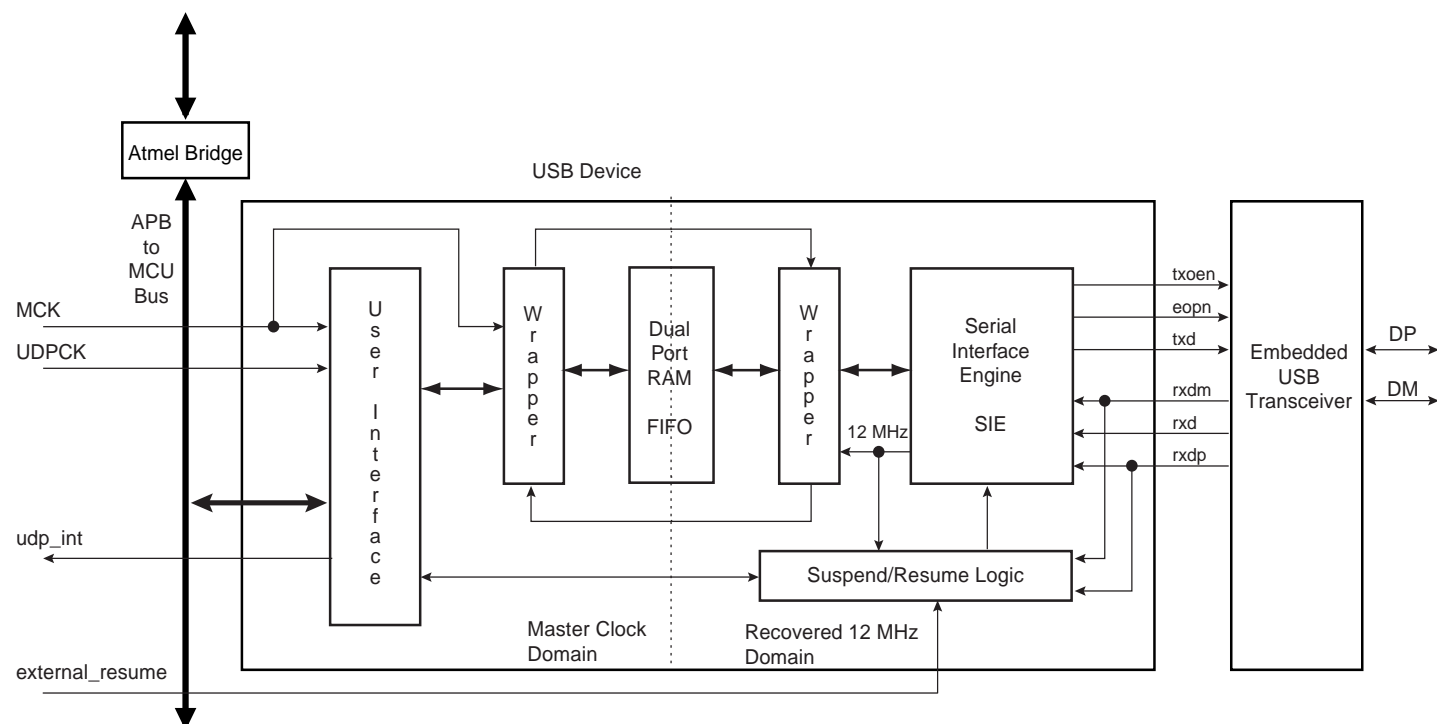

Access to the UDP is via the APB bus interface. Read and write to the data FIFO are done by reading and writing 8-bit values to APB registers.

The UDP peripheral requires two clocks: one peripheral clock used by the Master Clock domain (MCK) and a 48 MHz clock (UDPCK) used by the 12 MHz domain.

A USB 2.0 full-speed pad is embedded and controlled by the Serial Interface Engine (SIE).

The external_resume signal is optional. It allows the UDP peripheral to wake up once in system mode. The host is then notified that the device asks for a resume. This optional feature must also be negotiated with the host during the enumeration.

36.4 Product Dependencies

For further details on the USB Device hardware implementation, see the specific Product Properties document.

The USB physical transceiver is integrated into the product. The bidirectional differential signals DP and DM are available from the product boundary.

One I/O line may be used by the application to check that VBUS is still available from the host. Self-powered devices may use this entry to be notified that the host has been powered off. In this case, the pullup on DP must be disabled in order to prevent feeding current to the host. The application should disconnect the transceiver, then remove the pullup.

36.4.1 I/O Lines

DP and DM are not controlled by any PIO controllers. The embedded USB physical transceiver is controlled by the USB device peripheral.

To reserve an I/O line to check VBUS, the programmer must first program the PIO controller to assign this I/O in input PIO mode.

36.4.2 Power Management

The USB device peripheral requires a 48 MHz clock. This clock must be generated by a PLL with an accuracy of $\pm 0.25\%$.

Thus, the USB device receives two clocks from the Power Management Controller (PMC): the master clock, MCK, used to drive the peripheral user interface, and the UDPCK, used to interface with the bus USB signals (recovered 12 MHz domain).

WARNING: The UDP peripheral clock in the Power Management Controller (PMC) must be enabled before any read/write operations to the UDP registers including the UDP_TXVC register.

36.4.3 Interrupt

The USB device interface has an interrupt line connected to the Advanced Interrupt Controller (AIC). Handling the USB device interrupt requires programming the AIC before configuring the UDP.

36.5 Typical Connection

Figure 36-2. Board Schematic to Interface Device Peripheral

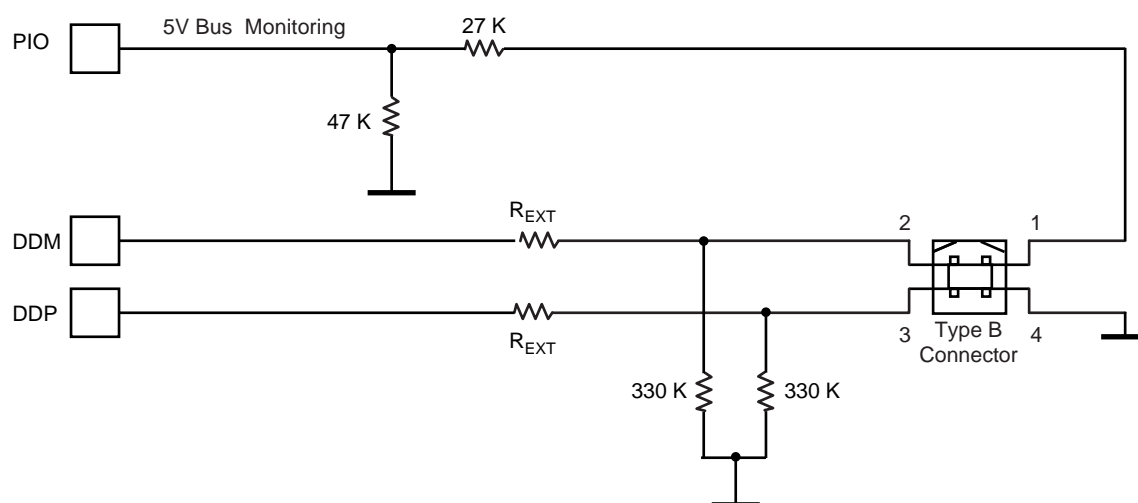

36.5.1 USB Device Transceiver

The USB device transceiver is embedded in the product. A few discrete components are required as follows:

- the application detects all device states as defined in chapter 9 of the USB specification;
 - VBUS monitoring
- to reduce power consumption the host is disconnected
- for line termination.

36.5.2 VBUS Monitoring

VBUS monitoring is required to detect host connection. VBUS monitoring is done using a standard PIO with internal pullup disabled. When the host is switched off, it should be considered as a disconnect, the pullup must be disabled in order to prevent powering the host through the pull-up resistor.

When the host is disconnected and the transceiver is enabled, then DDP and DDM are floating. This may lead to over consumption. A solution is to connect 330 K Ω pulldowns on DP and DM. These pulldowns do not alter DDP and DDM signal integrity.

A termination serial resistor must be connected to DP and DM. The resistor value is defined in the electrical specification of the product (R_{EXT}).

36.6 Functional Description

36.6.1 USB V2.0 Full-speed Introduction

The USB V2.0 full-speed provides communication services between host and attached USB devices. Each device is offered with a collection of communication flows (pipes) associated with each endpoint. Software on the host communicates with a USB device through a set of communication flows.

Figure 36-3. Example of USB V2.0 Full-speed Communication Control

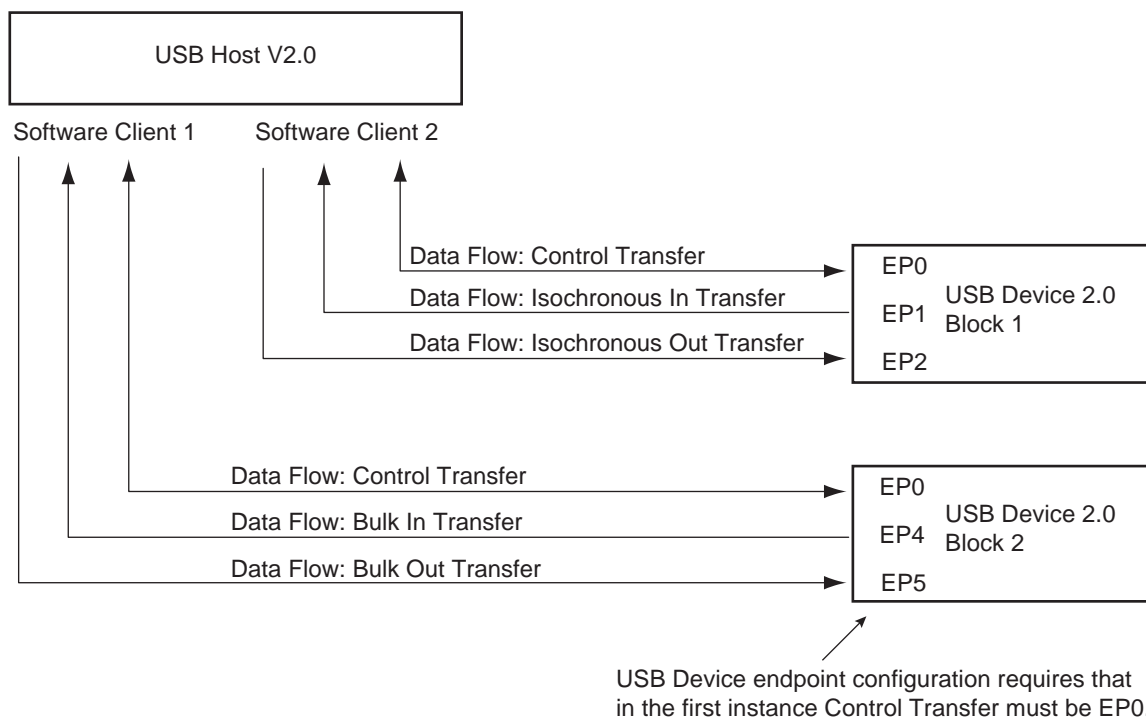

The Control Transfer endpoint EP0 is always used when a USB device is first configured (USB v. 2.0 specifications).

36.6.1.1 USB V2.0 Full-speed Transfer Types

A communication flow is carried over one of four transfer types defined by the USB device.

Table 36-2. USB Communication Flow

| Transfer | Direction | Bandwidth | Supported Endpoint Size | Error Detection | Retrying |
|-------------|----------------|----------------|-------------------------|-----------------|-----------|
| Control | Bidirectional | Not guaranteed | 8, 16, 32, 64 | Yes | Automatic |
| Isochronous | Unidirectional | Guaranteed | 256 | Yes | No |
| Interrupt | Unidirectional | Not guaranteed | ≤ 64 | Yes | Yes |
| Bulk | Unidirectional | Not guaranteed | 8, 16, 32, 64 | Yes | Yes |

36.6.1.2 USB Bus Transactions

Each transfer results in one or more transactions over the USB bus. There are three kinds of transactions flowing across the bus in packets:

1. Setup Transaction
2. Data IN Transaction
3. Data OUT Transaction

36.6.1.3 USB Transfer Event Definitions

As indicated below, transfers are sequential events carried out on the USB bus.

Table 36-3. USB Transfer Events

| Transfer | | Transaction |
|--------------------------|--------------------------------|---|
| Direction | Type | |
| CONTROL (bidirectional) | Control ⁽¹⁾⁽³⁾ | Setup transaction → Data IN transactions → Status OUT transaction Setup transaction → Data OUT transactions → Status IN transaction Setup transaction → Status IN transaction |
| IN (device toward host) | Bulk IN | Data IN transaction → Data IN transaction |
| | Interrupt IN | |
| | Isochronous IN ⁽²⁾ | |
| OUT (host toward device) | Bulk OUT | Data OUT transaction → Data OUT transaction |
| | Interrupt OUT | |
| | Isochronous OUT ⁽²⁾ | |

- Notes:
1. Control transfer must use endpoints with no ping-pong attributes.
 2. Isochronous transfers must use endpoints with ping-pong attributes.
 3. Control transfers can be aborted using a stall handshake.

A status transaction is a special type of host-to-device transaction used only in a control transfer. The control transfer must be performed using endpoints with no ping-pong attributes. According to the control sequence (read or write), the USB device sends or receives a status transaction.

Figure 36-4. Control Read and Write Sequences

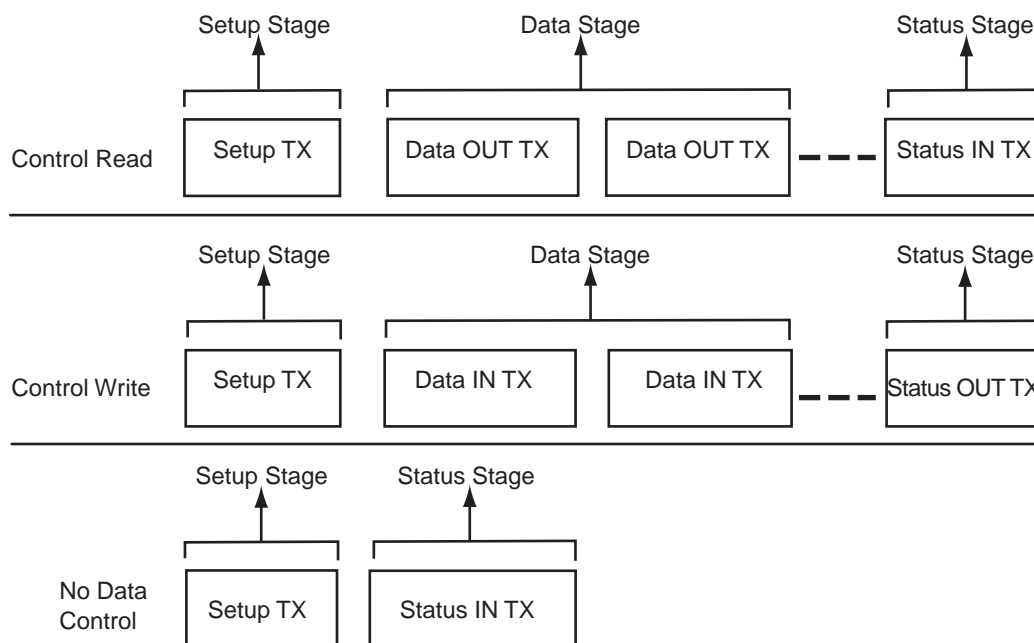

- Notes:
1. During the Status IN stage, the host waits for a zero length packet (Data IN transaction with no data) from the device using DATA1 PID. Refer to Chapter 8 of the *Universal Serial Bus Specification, Rev. 2.0*, for more information on the protocol layer.
 2. During the Status OUT stage, the host emits a zero length packet to the device (Data OUT transaction with no data).

36.6.2 Handling Transactions with USB V2.0 Device Peripheral

36.6.2.1 Setup Transaction

Setup is a special type of host-to-device transaction used during control transfers. Control transfers must be performed using endpoints with no ping-pong attributes. A setup transaction needs to be handled as soon as possible by the firmware. It is used to transmit requests from the host to the device. These requests are then handled by the USB device and may require more arguments. The arguments are sent to the device by a Data OUT transaction which follows the setup transaction. These requests may also return data. The data is carried out to the host by the next Data IN transaction which follows the setup transaction. A status transaction ends the control transfer.

When a setup transfer is received by the USB endpoint:

- The USB device automatically acknowledges the setup packet?
- RXSETUP is set in the UDP_CSRx
- An endpoint interrupt is generated while the RXSETUP is not cleared. This interrupt is carried out to the microcontroller if interrupts are enabled for this endpoint.

Thus, firmware must detect the RXSETUP polling the UDP_CSRx or catching an interrupt, read the setup packet in the FIFO, then clear the RXSETUP. RXSETUP cannot be cleared before the setup packet has been read in the FIFO. Otherwise, the USB device would accept the next Data OUT transfer and overwrite the setup packet in the FIFO.

Figure 36-5. Setup Transaction Followed by a Data OUT Transaction

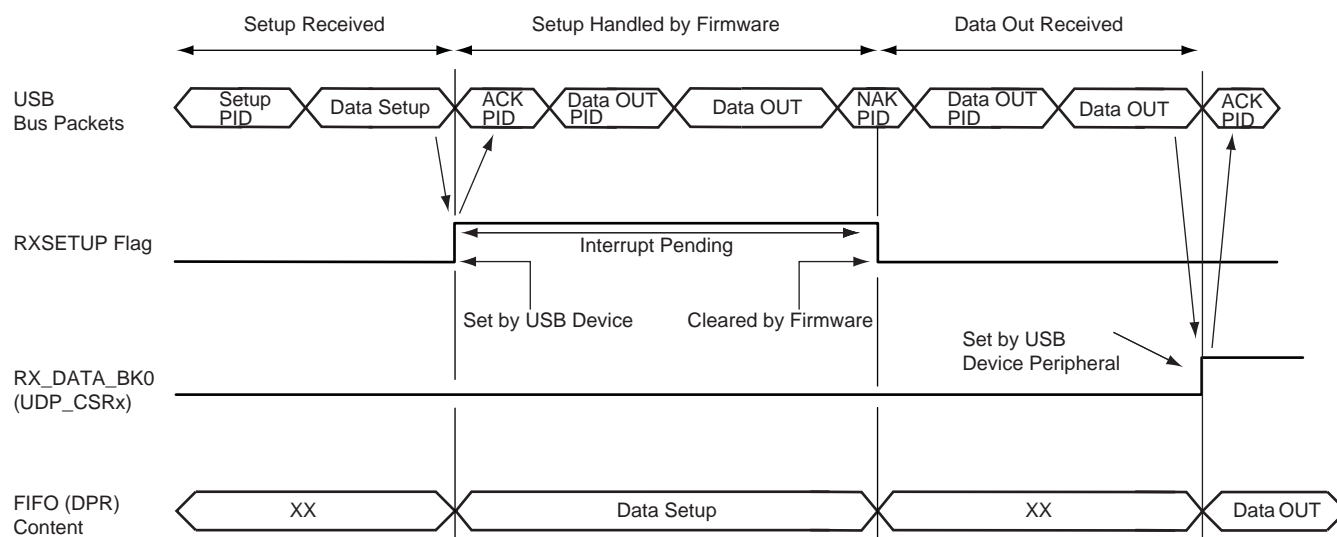

36.6.2.2 Data IN Transaction

Data IN transactions are used in control, isochronous, bulk and interrupt transfers and conduct the transfer of data from the device to the host. Data IN transactions in isochronous transfer must be done using endpoints with ping-pong attributes.

36.6.2.3 Using Endpoints Without Ping-pong Attributes

To perform a Data IN transaction using a non ping-pong endpoint:

1. The application checks if it is possible to write in the FIFO by polling TXPKTRDY in the endpoint's UDP_CSRx (TXPKTRDY must be cleared).
2. The application writes the first packet of data to be sent in the endpoint's FIFO, writing zero or more byte values in the endpoint's UDP_FDRx,
3. The application notifies the USB peripheral it has finished by setting the TXPKTRDY in the endpoint's UDP_CSRx.
4. The application is notified that the endpoint's FIFO has been released by the USB device when TXCOMP in the endpoint's UDP_CSRx has been set. Then an interrupt for the corresponding endpoint is pending while TXCOMP is set.
5. The microcontroller writes the second packet of data to be sent in the endpoint's FIFO, writing zero or more byte values in the endpoint's UDP_FDRx,
6. The microcontroller notifies the USB peripheral it has finished by setting the TXPKTRDY in the endpoint's UDP_CSRx.
7. The application clears the TXCOMP in the endpoint's UDP_CSRx.

After the last packet has been sent, the application must clear TXCOMP once this has been set.

TXCOMP is set by the USB device when it has received an ACK PID signal for the Data IN packet. An interrupt is pending while TXCOMP is set.

Warning: TX_COMP must be cleared after TX_PKTRDY has been set.

Note: Refer to Chapter 8 of the *Universal Serial Bus Specification, Rev 2.0*, for more information on the Data IN protocol layer.

Figure 36-6. Data IN Transfer for Non Ping-pong Endpoint

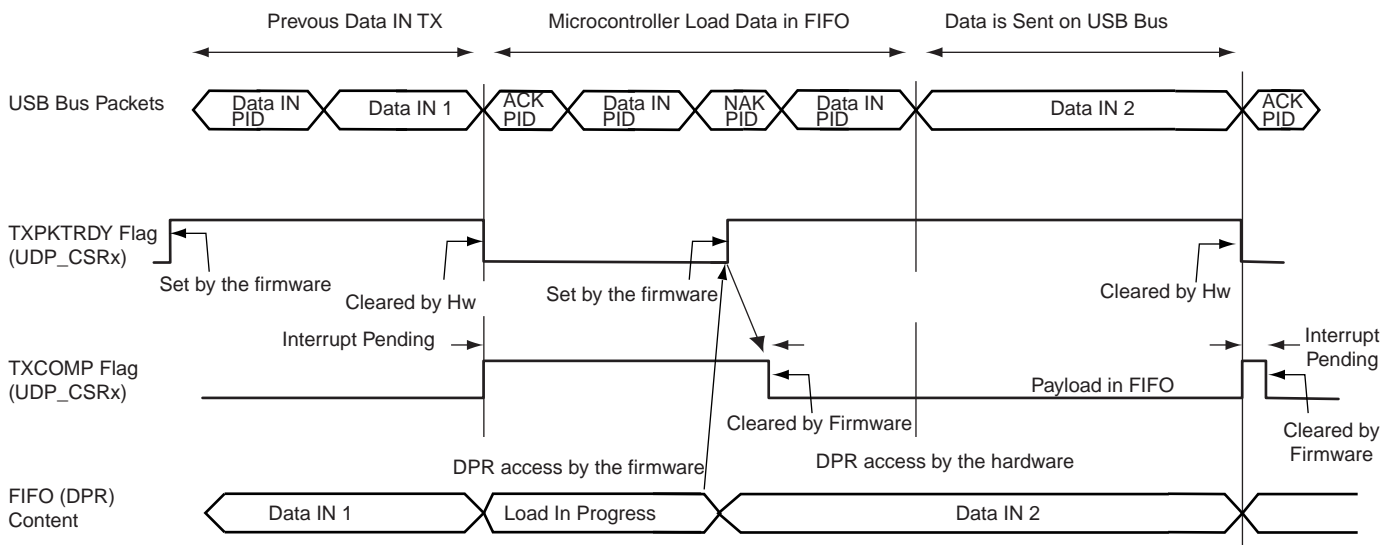

36.6.2.4 Using Endpoints With Ping-pong Attribute

The use of an endpoint with ping-pong attributes is necessary during isochronous transfer. This also allows handling the maximum bandwidth defined in the USB specification during bulk transfer. To be able to guarantee a constant or the maximum bandwidth, the microcontroller must prepare the next data payload to be sent while the current one is being sent by the USB device. Thus two banks of memory are used. While one is available for the microcontroller, the other one is locked by the USB device.

Figure 36-7. Bank Swapping Data IN Transfer for Ping-pong Endpoints

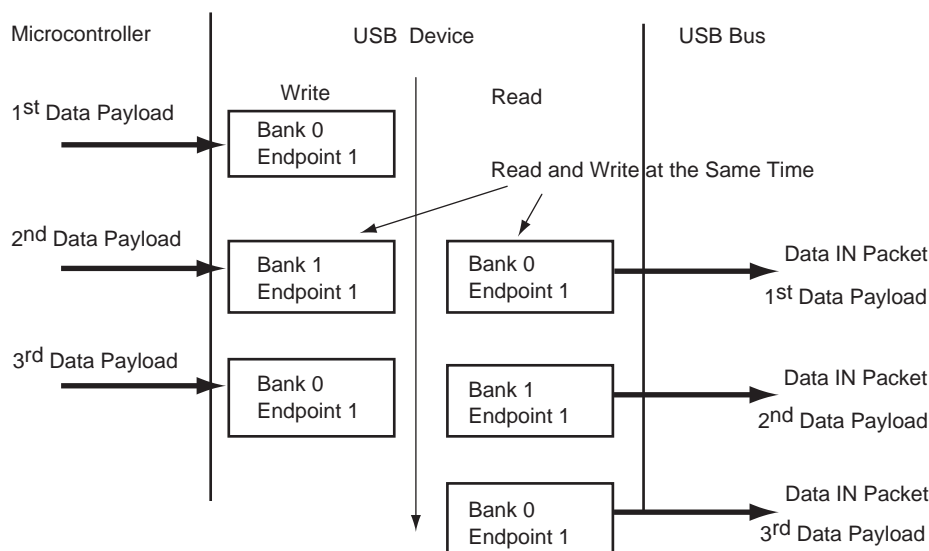

When using a ping-pong endpoint, the following procedures are required to perform Data IN transactions:

1. The microcontroller checks if it is possible to write in the FIFO by polling TXPKTRDY to be cleared in the endpoint's UDP_CSRx.
2. The microcontroller writes the first data payload to be sent in the FIFO (Bank 0), writing zero or more byte values in the endpoint's UDP_FDRx.
3. The microcontroller notifies the USB peripheral it has finished writing in Bank 0 of the FIFO by setting the TXPKTRDY in the endpoint's UDP_CSRx.
4. Without waiting for TXPKTRDY to be cleared, the microcontroller writes the second data payload to be sent in the FIFO (Bank 1), writing zero or more byte values in the endpoint's UDP_FDRx.
5. The microcontroller is notified that the first Bank has been released by the USB device when TXCOMP in the endpoint's UDP_CSRx is set. An interrupt is pending while TXCOMP is being set.
6. Once the microcontroller has received TXCOMP for the first Bank, it notifies the USB device that it has prepared the second Bank to be sent, raising TXPKTRDY in the endpoint's UDP_CSRx.
7. At this step, Bank 0 is available and the microcontroller can prepare a third data payload to be sent.

Figure 36-8. Data IN Transfer for Ping-pong Endpoint

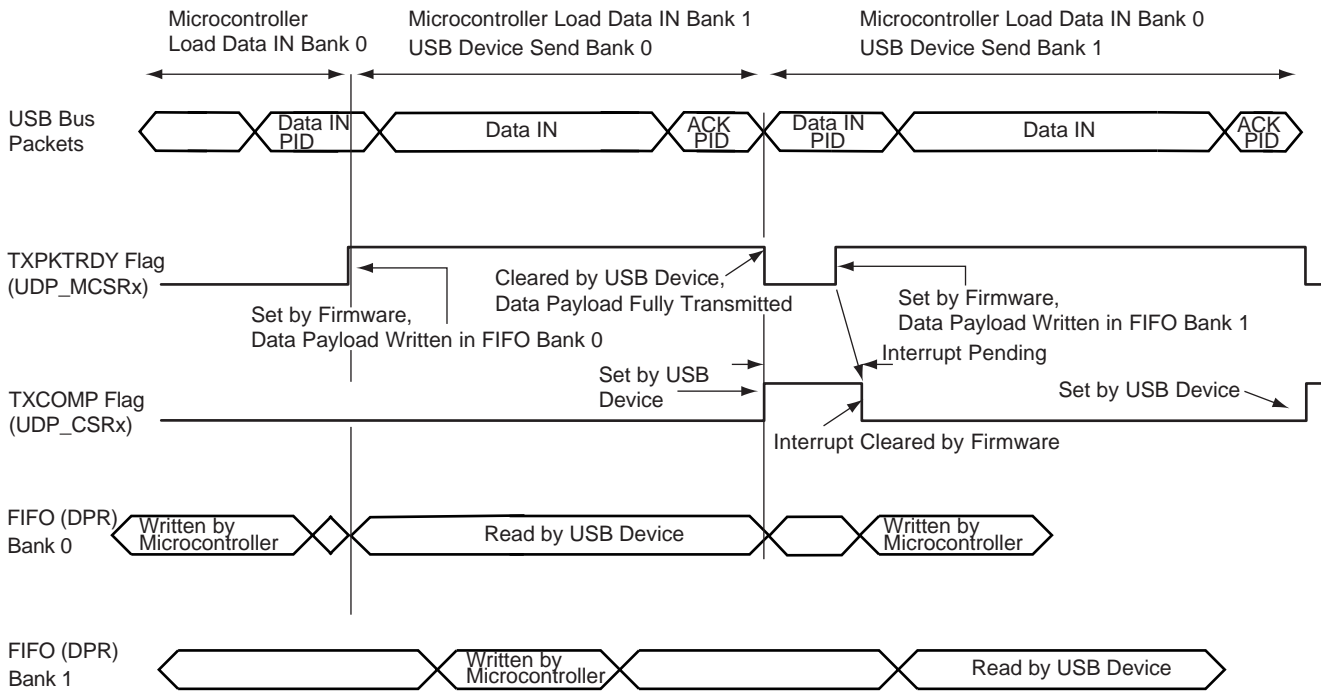

Warning: There is software critical path due to the fact that once the second bank is filled, the driver has to wait for TX_COMP to set TX_PKTRDY. If the delay between receiving TX_COMP is set and TX_PKTRDY is set too long, some Data IN packets may be NACKed, reducing the bandwidth.

Warning: TX_COMP must be cleared after TX_PKTRDY has been set.

36.6.2.5 Data OUT Transaction

Data OUT transactions are used in control, isochronous, bulk and interrupt transfers and conduct the transfer of data from the host to the device. Data OUT transactions in isochronous transfers must be done using endpoints with ping-pong attributes.

36.6.2.6 Data OUT Transaction Without Ping-pong Attributes

To perform a Data OUT transaction, using a non ping-pong endpoint:

1. The host generates a Data OUT packet.
2. This packet is received by the USB device endpoint. While the FIFO associated to this endpoint is being used by the microcontroller, a NAK PID is returned to the host. Once the FIFO is available, data are written to the FIFO by the USB device and an ACK is automatically carried out to the host.
3. The microcontroller is notified that the USB device has received a data payload polling RX_DATA_BK0 in the endpoint's UDP_CSRx. An interrupt is pending for this endpoint while RX_DATA_BK0 is set.
4. The number of bytes available in the FIFO is made available by reading RXYTECNT in the endpoint's UDP_CSRx.
5. The microcontroller carries out data received from the endpoint's memory to its memory. Data received is available by reading the endpoint's UDP_FDRx.
6. The microcontroller notifies the USB device that it has finished the transfer by clearing RX_DATA_BK0 in the endpoint's UDP_CSRx.
7. A new Data OUT packet can be accepted by the USB device.

Figure 36-9. Data OUT Transfer for Non Ping-pong Endpoints

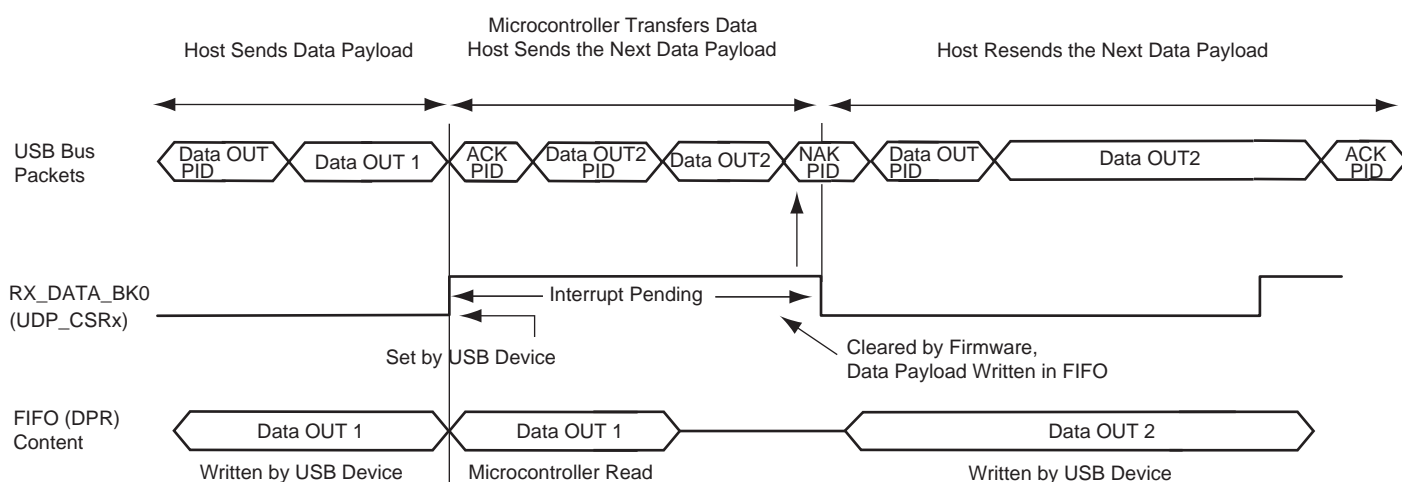

An interrupt is pending while the flag RX_DATA_BK0 is set. Memory transfer between the USB device, the FIFO and microcontroller memory can not be done after RX_DATA_BK0 has been cleared. Otherwise, the USB device would accept the next Data OUT transfer and overwrite the current Data OUT packet in the FIFO.

36.6.2.7 Using Endpoints With Ping-pong Attributes

During isochronous transfer, using an endpoint with ping-pong attributes is obligatory. To be able to guarantee a constant bandwidth, the microcontroller must read the previous data payload sent by the host, while the current data payload is received by the USB device. Thus two banks of memory are used. While one is available for the microcontroller, the other one is locked by the USB device.

Figure 36-10. Bank Swapping in Data OUT Transfers for Ping-pong Endpoints

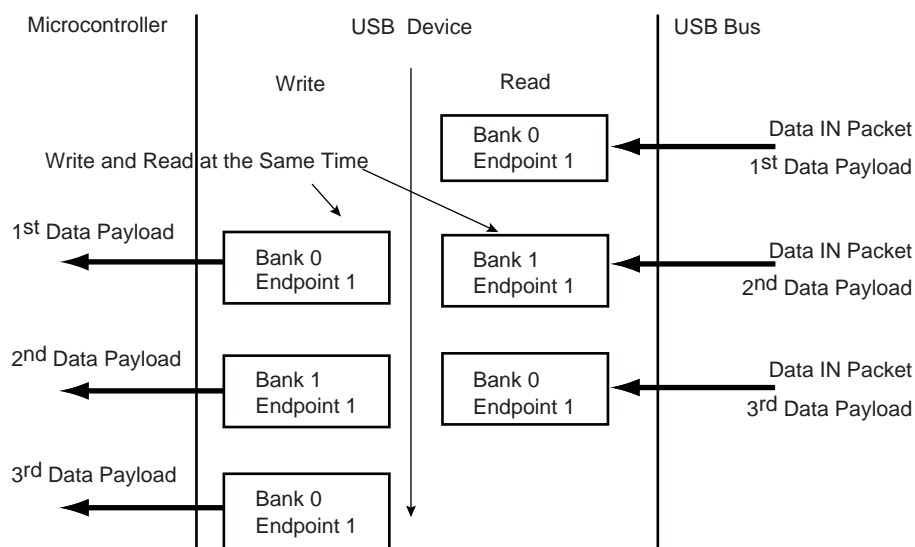

When using a ping-pong endpoint, the following procedures are required to perform Data OUT transactions:

1. The host generates a Data OUT packet.
2. This packet is received by the USB device endpoint. It is written in the endpoint's FIFO Bank 0.
3. The USB device sends an ACK PID packet to the host. The host can immediately send a second Data OUT packet. It is accepted by the device and copied to FIFO Bank 1.
4. The microcontroller is notified that the USB device has received a data payload, polling `RX_DATA_BK0` in the endpoint's `UDP_CSRx`. An interrupt is pending for this endpoint while `RX_DATA_BK0` is set.
5. The number of bytes available in the FIFO is made available by reading `RXBYTECNT` in the endpoint's `UDP_CSRx`.
6. The microcontroller transfers out data received from the endpoint's memory to the microcontroller's memory. Data received is made available by reading the endpoint's `UDP_FDRx`.
7. The microcontroller notifies the USB peripheral device that it has finished the transfer by clearing `RX_DATA_BK0` in the endpoint's `UDP_CSRx`.
8. A third Data OUT packet can be accepted by the USB peripheral device and copied in the FIFO Bank 0.
9. If a second Data OUT packet has been received, the microcontroller is notified by the flag `RX_DATA_BK1` set in the endpoint's `UDP_CSRx`. An interrupt is pending for this endpoint while `RX_DATA_BK1` is set.
10. The microcontroller transfers out data received from the endpoint's memory to the microcontroller's memory. Data received is available by reading the endpoint's `UDP_FDRx`.
11. The microcontroller notifies the USB device it has finished the transfer by clearing `RX_DATA_BK1` in the endpoint's `UDP_CSRx`.
12. A fourth Data OUT packet can be accepted by the USB device and copied in the FIFO Bank 0.

Figure 36-11. Data OUT Transfer for Ping-pong Endpoint

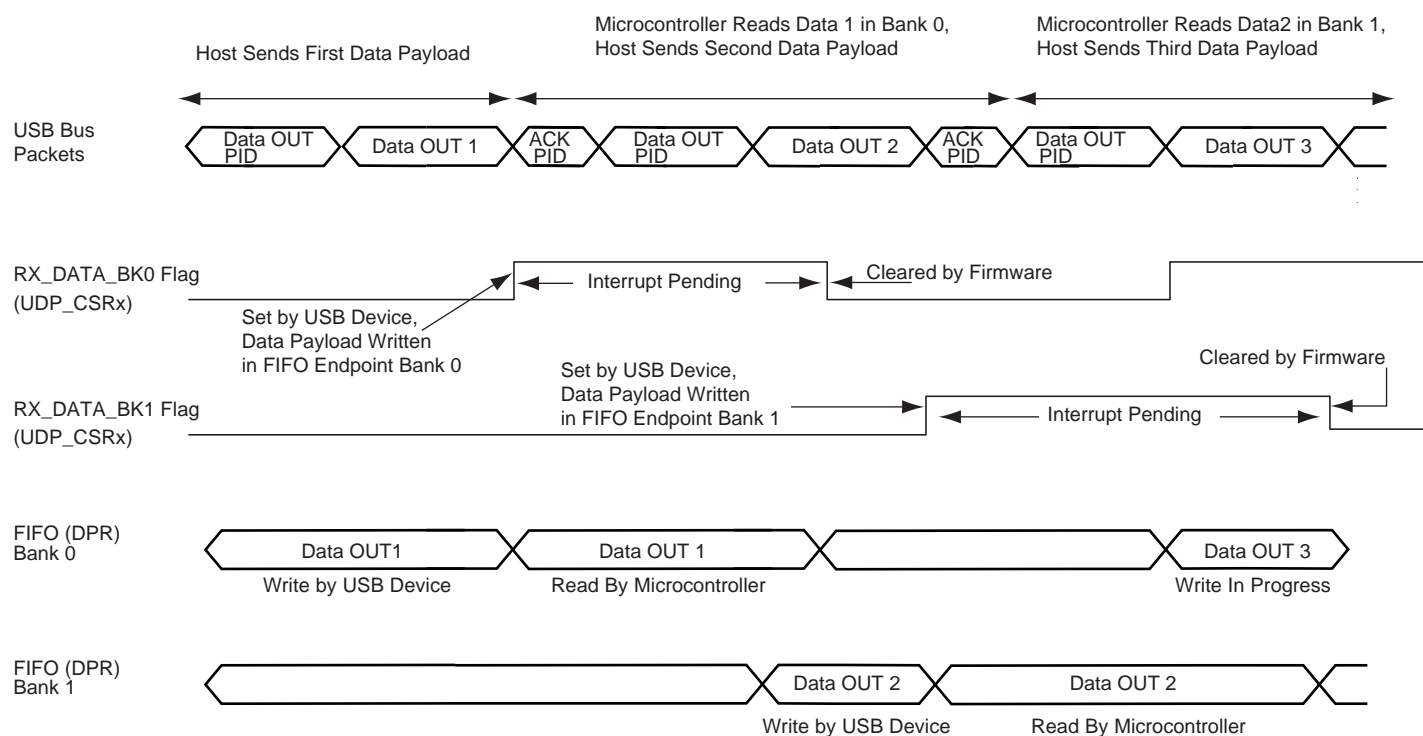

Note: An interrupt is pending while the RX_DATA_BK0 or RX_DATA_BK1 flag is set.

Warning: When RX_DATA_BK0 and RX_DATA_BK1 are both set, there is no way to determine which one to clear first. Thus the software must keep an internal counter to be sure to clear alternatively RX_DATA_BK0 then RX_DATA_BK1. This situation may occur when the software application is busy elsewhere and the two banks are filled by the USB host. Once the application comes back to the USB driver, the two flags are set.

36.6.2.8 Stall Handshake

A stall handshake can be used in one of two distinct occasions. (For more information on the stall handshake, refer to Chapter 8 of the *Universal Serial Bus Specification, Rev 2.0*.)

- A functional stall is used when the halt feature associated with the endpoint is set. (Refer to Chapter 9 of the *Universal Serial Bus Specification, Rev 2.0*, for more information on the halt feature.)
- To abort the current request, a protocol stall is used, but uniquely with control transfer.

The following procedure generates a stall packet:

1. The microcontroller sets the FORCESTALL flag in the UDP_CSRx endpoint's register.
2. The host receives the stall packet.
3. The microcontroller is notified that the device has sent the stall by polling the STALLSENT to be set. An endpoint interrupt is pending while STALLSENT is set. The microcontroller must clear STALLSENT to clear the interrupt.

When a setup transaction is received after a stall handshake, STALLSENT must be cleared in order to prevent interrupts due to STALLSENT being set.

Figure 36-12. Stall Handshake (Data IN Transfer)

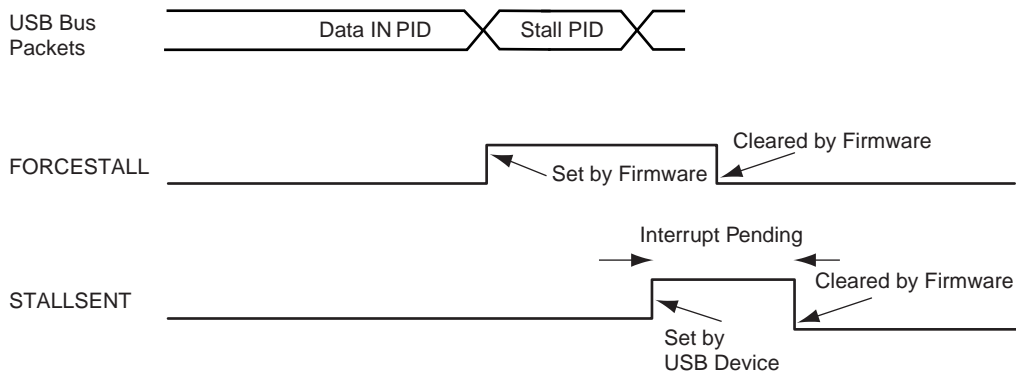
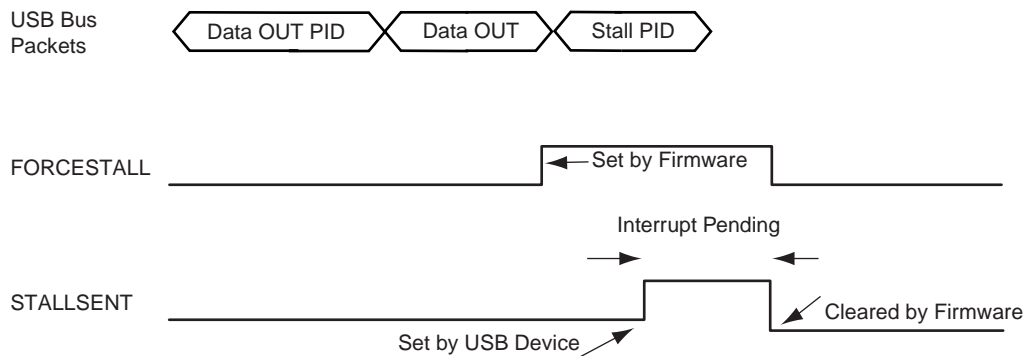

Figure 36-13. Stall Handshake (Data OUT Transfer)



36.6.2.9 Transmit Data Cancellation

Some endpoints have dual-banks whereas some endpoints have only one bank. The procedure to cancel transmission data held in these banks is described below.

To see the organization of dual-bank availability refer to [Table 36-1 "USB Endpoint Description"](#).

36.6.2.10 Endpoints Without Dual-Banks

There are two possibilities: In one case, TXPKTRDY field in UDP_CSR has already been set. In the other instance, TXPKTRDY is not set.

- TXPKTRDY is not set:
 - Reset the endpoint to clear the FIFO (pointers). (See [Section 36.7.9 "UDP Reset Endpoint Register"](#).)
- TXPKTRDY has already been set:
 - Clear TXPKTRDY so that no packet is ready to be sent
 - Reset the endpoint to clear the FIFO (pointers). (See [Section 36.7.9 "UDP Reset Endpoint Register"](#).)

36.6.2.11 Endpoints With Dual-Banks

There are two possibilities: In one case, TXPKTRDY field in UDP_CSR has already been set. In the other instance, TXPKTRDY is not set.

- TXPKTRDY is not set:
 - Reset the endpoint to clear the FIFO (pointers). (See [Section 36.7.9 "UDP Reset Endpoint Register"](#).)
- TXPKTRDY has already been set:
 - Clear TXPKTRDY and read it back until actually read at 0.
 - Set TXPKTRDY and read it back until actually read at 1.
 - Clear TXPKTRDY so that no packet is ready to be sent.
 - Reset the endpoint to clear the FIFO (pointers). (See [Section 36.7.9 "UDP Reset Endpoint Register"](#).)

36.6.3 Controlling Device States

A USB device has several possible states. Refer to Chapter 9 of the *Universal Serial Bus Specification, Rev 2.0*.

Figure 36-14. USB Device State Diagram

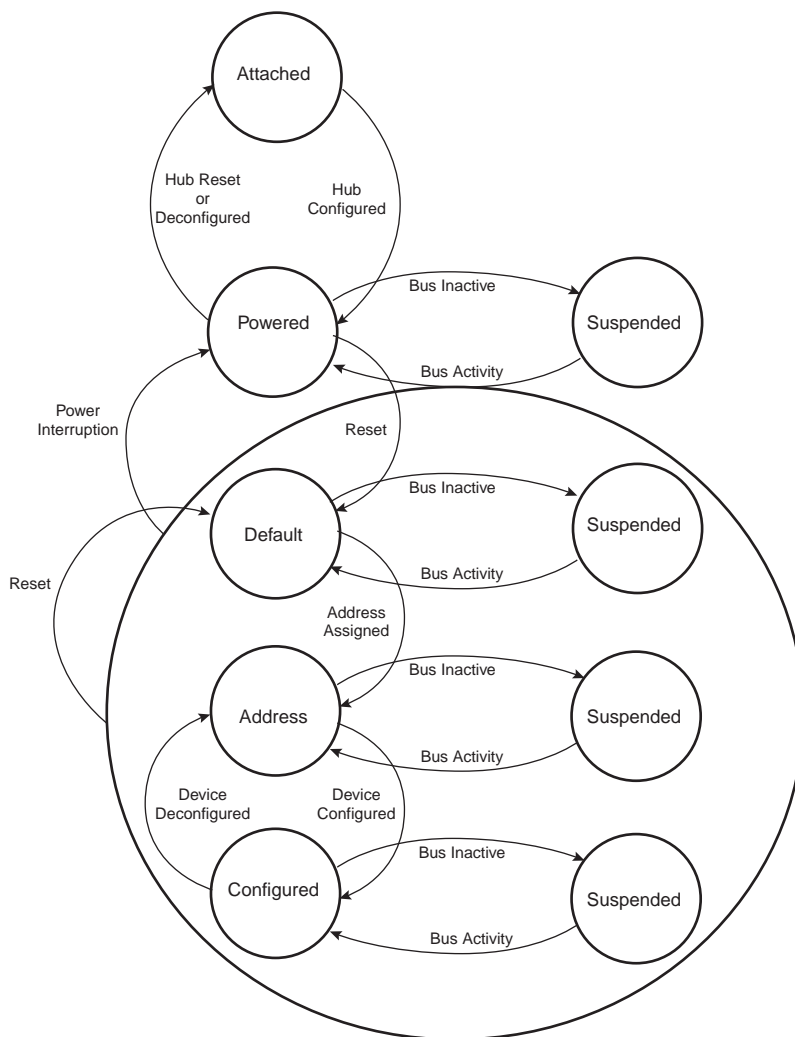

Movement from one state to another depends on the USB bus state or on standard requests sent through control transactions via the default endpoint (endpoint 0).

After a period of bus inactivity, the USB device enters Suspend Mode. Accepting Suspend/Resume requests from the USB host is mandatory. Constraints in Suspend Mode are very strict for bus-powered applications; devices may not consume more than 500 μA on the USB bus.

While in Suspend Mode, the host may wake up a device by sending a resume signal (bus activity) or a USB device may send a wakeup request to the host, e.g., waking up a PC by moving a USB mouse.

The wakeup feature is not mandatory for all devices and must be negotiated with the host.

36.6.3.1 Not Powered State

Self powered devices can detect 5V VBUS using a PIO as described in the typical connection section. When the device is not connected to a host, device power consumption can be reduced by disabling MCK for the UDP, disabling UDPCK and disabling the transceiver. DDP and DDM lines are pulled down by 330 K Ω resistors.

36.6.3.2 Entering Attached State

When no device is connected, the USB DP and DM signals are tied to GND by 15 K Ω pull-down resistors integrated in the hub downstream ports. When a device is attached to a hub downstream port, the device connects a 1.5 K Ω pull-up resistor on DP. The USB bus line goes into IDLE state, DP is pulled up by the device 1.5 K Ω resistor to 3.3V and DM is pulled down by the 15 K Ω resistor of the host. To enable integrated pullup, the UDP_PUP_ON bit in the USB_PUCR Bus Matrix register must be set.

Warning: To write to the UDP_TXVC register, MCK clock must be enabled on the UDP. This is done in the Power Management Controller.

After pullup connection, the device enters the powered state. In this state, the UDPCK and MCK must be enabled in the Power Management Controller. The transceiver can remain disabled.

36.6.3.3 From Powered State to Default State

After its connection to a USB host, the USB device waits for an end-of-bus reset. The unmaskable flag ENDBUSRES is set in the register UDP_ISR and an interrupt is triggered.

Once the ENDBUSRES interrupt has been triggered, the device enters Default State. In this state, the UDP software must:

- Enable the default endpoint, setting the EPEDS flag in the UDP_CSR[0] register and, optionally, enabling the interrupt for endpoint 0 by writing 1 to the UDP_IER. The enumeration then begins by a control transfer.
- Configure the interrupt mask register which has been reset by the USB reset detection
- Enable the transceiver clearing the TXVDIS flag in the UDP_TXVC register.

In this state UDPCK and MCK must be enabled.

Warning: Each time an ENDBUSRES interrupt is triggered, the Interrupt Mask Register and UDP_CSR have been reset.

36.6.3.4 From Default State to Address State

After a set address standard device request, the USB host peripheral enters the address state.

Warning: Before the device enters in address state, it must achieve the Status IN transaction of the control transfer, i.e., the UDP device sets its new address once the TXCOMP flag in the UDP_CSR[0] register has been received and cleared.

To move to address state, the driver software sets the FADDEN flag in the UDP_GLB_STAT register, sets its new address, and sets the FEN bit in the UDP_FADDR.

36.6.3.5 From Address State to Configured State

Once a valid Set Configuration standard request has been received and acknowledged, the device enables endpoints corresponding to the current configuration. This is done by setting the EPEDS and EPTYPE fields in the UDP_CSRx and, optionally, enabling corresponding interrupts in the UDP_IER.

36.6.3.6 Entering in Suspend State

When a Suspend (no bus activity on the USB bus) is detected, the RXSUSP signal in the UDP_ISR is set. This triggers an interrupt if the corresponding bit is set in the UDP_IMR. This flag is cleared by writing to the UDP_ICR. Then the device enters Suspend Mode.

In this state bus powered devices must drain less than 500uA from the 5V VBUS. As an example, the microcontroller switches to slow clock, disables the PLL and main oscillator, and goes into Idle Mode. It may also switch off other devices on the board.

The USB device peripheral clocks can be switched off. Resume event is asynchronously detected. MCK and UDPCK can be switched off in the Power Management controller and the USB transceiver can be disabled by setting the TXVDIS field in the UDP_TXVC register.

Warning: Read, write operations to the UDP registers are allowed only if MCK is enabled for the UDP peripheral. Switching off MCK for the UDP peripheral must be one of the last operations after writing to the UDP_TXVC and acknowledging the RXSUSP.

36.6.3.7 Receiving a Host Resume

In suspend mode, a resume event on the USB bus line is detected asynchronously, transceiver and clocks are disabled (however the pullup shall not be removed).

Once the resume is detected on the bus, the WAKEUP signal in the UDP_ISR is set. It may generate an interrupt if the corresponding bit in the UDP_IMR is set. This interrupt may be used to wake up the core, enable PLL and main oscillators and configure clocks.

Warning: Read, write operations to the UDP registers are allowed only if MCK is enabled for the UDP peripheral. MCK for the UDP must be enabled before clearing the WAKEUP bit in the UDP_ICR and clearing TXVDIS in the UDP_TXVC register.

36.6.3.8 Sending a Device Remote Wakeup

In Suspend state it is possible to wake up the host sending an external resume.

- The device must wait at least 5 ms after being entered in suspend before sending an external resume.
- The device has 10 ms from the moment it starts to drain current and it forces a K state to resume the host.
- The device must force a K state from 1 to 15 ms to resume the host

To force a K state to the bus (DM at 3.3V and DP tied to GND), it is possible to use a transistor to connect a pullup on DM. The K state is obtained by disabling the pullup on DP and enabling the pullup on DM. This should be under the control of the application.

Figure 36-15. Board Schematic to Drive a K State

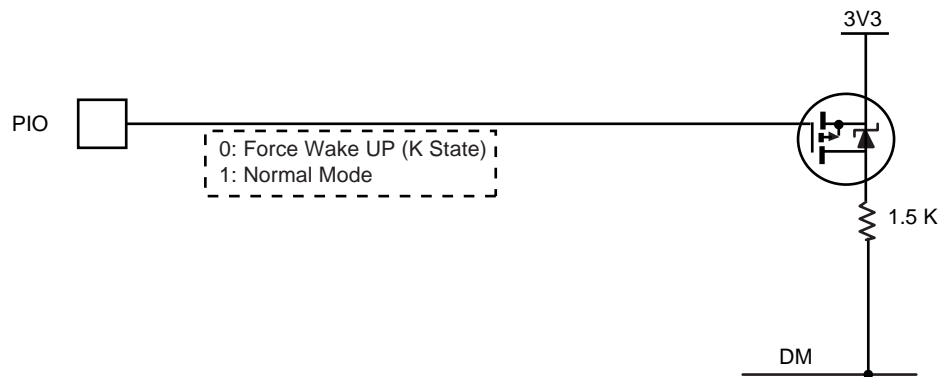

36.7 USB Device Port (UDP) User Interface

WARNING: The UDP peripheral clock in the Power Management Controller (PMC) must be enabled before any read/write operations to the UDP registers including the UDP_TXVC register.

Table 36-4. Register Mapping

| Offset | Register | Name | Access | Reset |
|-----------------------------|--------------------------------------|-------------------------|------------|------------------|
| 0x000 | Frame Number Register | UDP_FRM_NUM | Read-only | 0x0000_0000 |
| 0x004 | Global State Register | UDP_GLB_STAT | Read/Write | 0x0000_0010 |
| 0x008 | Function Address Register | UDP_FADDR | Read/Write | 0x0000_0100 |
| 0x00C | Reserved | – | – | – |
| 0x010 | Interrupt Enable Register | UDP_IER | Write-only | – |
| 0x014 | Interrupt Disable Register | UDP_IDR | Write-only | – |
| 0x018 | Interrupt Mask Register | UDP_IMR | Read-only | 0x0000_1200 |
| 0x01C | Interrupt Status Register | UDP_ISR | Read-only | – ⁽¹⁾ |
| 0x020 | Interrupt Clear Register | UDP_ICR | Write-only | – |
| 0x024 | Reserved | – | – | – |
| 0x028 | Reset Endpoint Register | UDP_RST_EP | Read/Write | 0x0000_0000 |
| 0x02C | Reserved | – | – | – |
| 0x030 + 0x4 * (ept_num - 1) | Endpoint Control and Status Register | UDP_CSR | Read/Write | 0x0000_0000 |
| 0x050 + 0x4 * (ept_num - 1) | Endpoint FIFO Data Register | UDP_FDR | Read/Write | 0x0000_0000 |
| 0x070 | Reserved | – | – | – |
| 0x074 | Transceiver Control Register | UDP_TXVC ⁽²⁾ | Read/Write | 0x0000_0000 |
| 0x078–0xFC | Reserved | – | – | – |

- Notes:
1. Reset values are not defined for UDP_ISR.
 2. See Warning above the "Register Mapping" on this page.

36.7.1 UDP Frame Number Register

Name: UDP_FRM_NUM

Address: 0xFFFFA4000

Access: Read-only

| | | | | | | | |
|---------|----|----|----|----|---------|--------|---------|
| 31 | 30 | 29 | 28 | 27 | 26 | 25 | 24 |
| – | – | – | – | – | – | – | – |
| 23 | 22 | 21 | 20 | 19 | 18 | 17 | 16 |
| – | – | – | – | – | – | FRM_OK | FRM_ERR |
| 15 | 14 | 13 | 12 | 11 | 10 | 9 | 8 |
| – | – | – | – | – | FRM_NUM | | |
| 7 | 6 | 5 | 4 | 3 | 2 | 1 | 0 |
| FRM_NUM | | | | | | | |

- **FRM_NUM[10:0]: Frame Number as Defined in the Packet Field Formats**

This 11-bit value is incremented by the host on a per frame basis. This value is updated at each start of frame.

Value Updated at the SOF_EOP (Start of Frame End of Packet).

- **FRM_ERR: Frame Error**

This bit is set at SOF_EOP when the SOF packet is received containing an error.

This bit is reset upon receipt of SOF_PID.

- **FRM_OK: Frame OK**

This bit is set at SOF_EOP when the SOF packet is received without any error.

This bit is reset upon receipt of SOF_PID (Packet Identification).

In the Interrupt Status Register, the SOF interrupt is updated upon receiving SOF_PID. This bit is set without waiting for EOP.

Note: In the 8-bit Register Interface, FRM_OK is bit 4 of FRM_NUM_H and FRM_ERR is bit 3 of FRM_NUM_L.

36.7.2 UDP Global State Register

Name: UDP_GLB_STAT

Address: 0xFFFFA4004

Access: Read/Write

| | | | | | | | |
|----|----|----|----|----|----|--------|--------|
| 31 | 30 | 29 | 28 | 27 | 26 | 25 | 24 |
| – | – | – | – | – | – | – | – |
| 23 | 22 | 21 | 20 | 19 | 18 | 17 | 16 |
| – | – | – | – | – | – | – | – |
| 15 | 14 | 13 | 12 | 11 | 10 | 9 | 8 |
| – | – | – | – | – | – | – | – |
| 7 | 6 | 5 | 4 | 3 | 2 | 1 | 0 |
| – | – | – | – | – | – | CONFIG | FADDEN |

This register is used to get and set the device state as specified in Chapter 9 of the *USB Serial Bus Specification, Rev.2.0*.

• FADDEN: Function Address Enable

Read:

0: Device is not in address state.

1: Device is in address state.

Write:

0: No effect, only a reset can bring back a device to the default state.

1: Sets device in address state. This occurs after a successful Set Address request. Beforehand, the UDP_FADDR must have been initialized with Set Address parameters. Set Address must complete the Status Stage before setting FADDEN. Refer to chapter 9 of the *Universal Serial Bus Specification, Rev. 2.0* for more details.

• CONFIG: Configured

Read:

0: Device is not in configured state.

1: Device is in configured state.

Write:

0: Sets device in a non configured state

1: Sets device in configured state.

The device is set in configured state when it is in address state and receives a successful Set Configuration request. Refer to Chapter 9 of the *Universal Serial Bus Specification, Rev. 2.0* for more details.

36.7.3 UDP Function Address Register

Name: UDP_FADDR

Address: 0xFFFA4008

Access: Read/Write

| | | | | | | | |
|----|------|----|----|----|----|----|-----|
| 31 | 30 | 29 | 28 | 27 | 26 | 25 | 24 |
| – | – | – | – | – | – | – | – |
| 23 | 22 | 21 | 20 | 19 | 18 | 17 | 16 |
| – | – | – | – | – | – | – | – |
| 15 | 14 | 13 | 12 | 11 | 10 | 9 | 8 |
| – | – | – | – | – | – | – | FEN |
| 7 | 6 | 5 | 4 | 3 | 2 | 1 | 0 |
| – | FADD | | | | | | |

- **FADD[6:0]: Function Address Value**

The Function Address Value must be programmed by firmware once the device receives a set address request from the host, and has achieved the status stage of the no-data control sequence. Refer to the *Universal Serial Bus Specification, Rev. 2.0* for more information. After power up or reset, the function address value is set to 0.

- **FEN: Function Enable**

Read:

0: Function endpoint disabled.

1: Function endpoint enabled.

Write:

0: Disables function endpoint.

1: Default value.

The Function Enable bit (FEN) allows the microcontroller to enable or disable the function endpoints. The microcontroller sets this bit after receipt of a reset from the host. Once this bit is set, the USB device is able to accept and transfer data packets from and to the host.

36.7.4 UDP Interrupt Enable Register

Name: UDP_IER

Address: 0xFFFA4010

Access: Write-only

| | | | | | | | |
|----|----|--------|--------|--------|--------|--------|--------|
| 31 | 30 | 29 | 28 | 27 | 26 | 25 | 24 |
| – | – | – | – | – | – | – | – |
| 23 | 22 | 21 | 20 | 19 | 18 | 17 | 16 |
| – | – | – | – | – | – | – | – |
| 15 | 14 | 13 | 12 | 11 | 10 | 9 | 8 |
| – | – | WAKEUP | – | SOFINT | – | RXRSM | RXSUSP |
| 7 | 6 | 5 | 4 | 3 | 2 | 1 | 0 |
| – | – | EP5INT | EP4INT | EP3INT | EP2INT | EP1INT | EP0INT |

- **EP0INT: Enable Endpoint 0 Interrupt**

- **EP1INT: Enable Endpoint 1 Interrupt**

- **EP2INT: Enable Endpoint 2 Interrupt**

- **EP3INT: Enable Endpoint 3 Interrupt**

- **EP4INT: Enable Endpoint 4 Interrupt**

- **EP5INT: Enable Endpoint 5 Interrupt**

0: No effect.

1: Enables corresponding Endpoint Interrupt.

- **RXSUSP: Enable UDP Suspend Interrupt**

0: No effect.

1: Enables UDP Suspend Interrupt.

- **RXRSM: Enable UDP Resume Interrupt**

0: No effect.

1: Enables UDP Resume Interrupt.

- **SOFINT: Enable Start Of Frame Interrupt**

0: No effect.

1: Enables Start Of Frame Interrupt.

- **WAKEUP: Enable UDP bus Wakeup Interrupt**

0: No effect.

1: Enables USB bus Interrupt.

36.7.5 UDP Interrupt Disable Register

Name: UDP_IDR

Address: 0xFFFA4014

Access: Write-only

| | | | | | | | |
|----|----|--------|--------|--------|--------|--------|--------|
| 31 | 30 | 29 | 28 | 27 | 26 | 25 | 24 |
| – | – | – | – | – | – | – | – |
| 23 | 22 | 21 | 20 | 19 | 18 | 17 | 16 |
| – | – | – | – | – | – | – | – |
| 15 | 14 | 13 | 12 | 11 | 10 | 9 | 8 |
| – | – | WAKEUP | – | SOFINT | – | RXRSM | RXSUSP |
| 7 | 6 | 5 | 4 | 3 | 2 | 1 | 0 |
| – | – | EP5INT | EP4INT | EP3INT | EP2INT | EP1INT | EP0INT |

- **EP0INT: Disable Endpoint 0 Interrupt**
- **EP1INT: Disable Endpoint 1 Interrupt**
- **EP2INT: Disable Endpoint 2 Interrupt**
- **EP3INT: Disable Endpoint 3 Interrupt**
- **EP4INT: Disable Endpoint 4 Interrupt**
- **EP5INT: Disable Endpoint 5 Interrupt**
0: No effect.
1: Disables corresponding Endpoint Interrupt.
- **RXSUSP: Disable UDP Suspend Interrupt**
0: No effect.
1: Disables UDP Suspend Interrupt.
- **RXRSM: Disable UDP Resume Interrupt**
0: No effect.
1: Disables UDP Resume Interrupt.
- **SOFINT: Disable Start Of Frame Interrupt**
0: No effect.
1: Disables Start Of Frame Interrupt
- **WAKEUP: Disable USB Bus Interrupt**
0: No effect.
1: Disables USB Bus Wakeup Interrupt.

36.7.6 UDP Interrupt Mask Register

Name: UDP_IMR
Address: 0xFFFFA4018
Access: Read-only

| | | | | | | | |
|----|----|--------|--------|--------|--------|--------|--------|
| 31 | 30 | 29 | 28 | 27 | 26 | 25 | 24 |
| – | – | – | – | – | – | – | – |
| 23 | 22 | 21 | 20 | 19 | 18 | 17 | 16 |
| – | – | – | – | – | – | – | – |
| 15 | 14 | 13 | 1 | 11 | 10 | 9 | 8 |
| – | – | WAKEUP | BIT12 | SOFINT | – | RXRSM | RXSUSP |
| 7 | 6 | 5 | 4 | 3 | 2 | 1 | 0 |
| – | – | EP5INT | EP4INT | EP3INT | EP2INT | EP1INT | EP0INT |

- **EP0INT: Mask Endpoint 0 Interrupt**

- **EP1INT: Mask Endpoint 1 Interrupt**

- **EP2INT: Mask Endpoint 2 Interrupt**

- **EP3INT: Mask Endpoint 3 Interrupt**

- **EP4INT: Mask Endpoint 4 Interrupt**

- **EP5INT: Mask Endpoint 5 Interrupt**

0: Corresponding Endpoint Interrupt is disabled.

1: Corresponding Endpoint Interrupt is enabled.

- **RXSUSP: Mask UDP Suspend Interrupt**

0: UDP Suspend Interrupt is disabled.

1: UDP Suspend Interrupt is enabled.

- **RXRSM: Mask UDP Resume Interrupt.**

0: UDP Resume Interrupt is disabled.

1: UDP Resume Interrupt is enabled.

- **SOFINT: Mask Start Of Frame Interrupt**

0: Start of Frame Interrupt is disabled.

1: Start of Frame Interrupt is enabled.

- **BIT12: UDP_IMR Bit 12**

Bit 12 of UDP_IMR cannot be masked and is always read at 1.

- **WAKEUP: USB Bus WAKEUP Interrupt**

0: USB Bus Wakeup Interrupt is disabled.

1: USB Bus Wakeup Interrupt is enabled.

Note: When the USB block is in suspend mode, the application may power down the USB logic. In this case, any USB HOST resume request that is made must be taken into account and, thus, the reset value of the RXRSM bit of the register UDP_IMR is enabled.

36.7.7 UDP Interrupt Status Register

Name: UDP_ISR
Address: 0xFFFFA401C
Access: Read-only

| | | | | | | | |
|----|----|--------|-----------|--------|--------|--------|--------|
| 31 | 30 | 29 | 28 | 27 | 26 | 25 | 24 |
| – | – | – | – | – | – | – | – |
| 23 | 22 | 21 | 20 | 19 | 18 | 17 | 16 |
| – | – | – | – | – | – | – | – |
| 15 | 14 | 13 | 12 | 11 | 10 | 9 | 8 |
| – | – | WAKEUP | ENDBUSRES | SOFINT | – | RXRSM | RXSUSP |
| 7 | 6 | 5 | 4 | 3 | 2 | 1 | 0 |
| – | – | EP5INT | EP4INT | EP3INT | EP2INT | EP1INT | EP0INT |

- **EP0INT: Endpoint 0 Interrupt Status**
- **EP1INT: Endpoint 1 Interrupt Status**
- **EP2INT: Endpoint 2 Interrupt Status**
- **EP3INT: Endpoint 3 Interrupt Status**
- **EP4INT: Endpoint 4 Interrupt Status**
- **EP5INT: Endpoint 5 Interrupt Status**

0: No Endpoint0 Interrupt pending.

1: Endpoint0 Interrupt has been raised.

Several signals can generate this interrupt. The reason can be found by reading UDP_CSR0:

RXSETUP set to 1

RX_DATA_BK0 set to 1

RX_DATA_BK1 set to 1

TXCOMP set to 1

STALLSENT set to 1

EP0INT is a sticky bit. Interrupt remains valid until EP0INT is cleared by writing in the corresponding UDP_CSR0 bit.

- **RXSUSP: UDP Suspend Interrupt Status**

0: No UDP Suspend Interrupt pending.

1: UDP Suspend Interrupt has been raised.

The USB device sets this bit when it detects no activity for 3ms. The USB device enters Suspend mode.

- **RXRSM: UDP Resume Interrupt Status**

0: No UDP Resume Interrupt pending.

1: UDP Resume Interrupt has been raised.

The USB device sets this bit when a UDP resume signal is detected at its port.

After reset, the state of this bit is undefined, the application must clear this bit by setting the RXRSM flag in the UDP_ICR.

- **SOFINT: Start of Frame Interrupt Status**

0: No Start of Frame Interrupt pending.

1: Start of Frame Interrupt has been raised.

This interrupt is raised each time a SOF token has been detected. It can be used as a synchronization signal by using isochronous endpoints.

- **ENDBUSRES: End of BUS Reset Interrupt Status**

0: No End of Bus Reset Interrupt pending.

1: End of Bus Reset Interrupt has been raised.

This interrupt is raised at the end of a UDP reset sequence. The USB device must prepare to receive requests on the endpoint 0. The host starts the enumeration, then performs the configuration.

- **WAKEUP: UDP Resume Interrupt Status**

0: No Wakeup Interrupt pending.

1: A Wakeup Interrupt (USB Host Sent a RESUME or RESET) occurred since the last clear.

After reset the state of this bit is undefined, the application must clear this bit by setting the WAKEUP flag in the UDP_ICR.

36.7.8 UDP Interrupt Clear Register

Name: UDP_ICR

Address: 0xFFFFA4020

Access: Write-only

| | | | | | | | |
|----|----|--------|-----------|--------|----|-------|--------|
| 31 | 30 | 29 | 28 | 27 | 26 | 25 | 24 |
| – | – | – | – | – | – | – | – |
| 23 | 22 | 21 | 20 | 19 | 18 | 17 | 16 |
| – | – | – | – | – | – | – | – |
| 15 | 14 | 13 | 12 | 11 | 10 | 9 | 8 |
| – | – | WAKEUP | ENDBUSRES | SOFINT | – | RXRSM | RXSUSP |
| 7 | 6 | 5 | 4 | 3 | 2 | 1 | 0 |
| – | – | – | – | – | – | – | – |

- **RXSUSP: Clear UDP Suspend Interrupt**

0: No effect.

1: Clears UDP Suspend Interrupt.

- **RXRSM: Clear UDP Resume Interrupt**

0: No effect.

1: Clears UDP Resume Interrupt.

- **SOFINT: Clear Start Of Frame Interrupt**

0: No effect.

1: Clears Start Of Frame Interrupt.

- **ENDBUSRES: Clear End of Bus Reset Interrupt**

0: No effect.

1: Clears End of Bus Reset Interrupt.

- **WAKEUP: Clear Wakeup Interrupt**

0: No effect.

1: Clears Wakeup Interrupt.

36.7.9 UDP Reset Endpoint Register

Name: UDP_RST_EP

Address: 0xFFFA4028

Access: Read/Write

| | | | | | | | |
|----|----|-----|-----|-----|-----|-----|-----|
| 31 | 30 | 29 | 28 | 27 | 26 | 25 | 24 |
| – | – | – | – | – | – | – | – |
| 23 | 22 | 21 | 20 | 19 | 18 | 17 | 16 |
| – | – | – | – | – | – | – | – |
| 15 | 14 | 13 | 12 | 11 | 10 | 9 | 8 |
| – | – | – | – | – | – | – | – |
| 7 | 6 | 5 | 4 | 3 | 2 | 1 | 0 |
| – | – | EP5 | EP4 | EP3 | EP2 | EP1 | EP0 |

- **EP0: Reset Endpoint 0**
- **EP1: Reset Endpoint 1**
- **EP2: Reset Endpoint 2**
- **EP3: Reset Endpoint 3**
- **EP4: Reset Endpoint 4**
- **EP5: Reset Endpoint 5**

This flag is used to reset the FIFO associated with the endpoint and the bit RXBYTECOUNT in the register UDP_CSRx. It also resets the data toggle to DATA0. It is useful after removing a HALT condition on a BULK endpoint. Refer to Chapter 5.8.5 in the *USB Serial Bus Specification, Rev.2.0*.

Warning: This flag must be cleared at the end of the reset. It does not clear UDP_CSRx flags.

0: No reset.

1: Forces the corresponding endpoint FIFO pointers to 0, therefore RXBYTECNT field is read at 0 in UDP_CSRx.

Resetting the endpoint is a two-step operation:

1. Set the corresponding EPx field.
2. Clear the corresponding EPx field.

36.7.10 UDP Endpoint Control and Status Register

Name: UDP_CSRx [x = 0..5]

Address: 0xFFFFA402C

Access: Read/Write

| | | | | | | | |
|-----------|-------------|------------|----------|-----------------------|-----------|-------------|--------|
| 31 | 30 | 29 | 28 | 27 | 26 | 25 | 24 |
| - | - | - | - | - | RXBYTECNT | | |
| 23 | 22 | 21 | 20 | 19 | 18 | 17 | 16 |
| RXBYTECNT | | | | | | | |
| 15 | 14 | 13 | 12 | 11 | 10 | 9 | 8 |
| EPEDS | - | - | - | DTGLE | EPTYPE | | |
| 7 | 6 | 5 | 4 | 3 | 2 | 1 | 0 |
| DIR | RX_DATA_BK1 | FORCESTALL | TXPKTRDY | STALLSENT ISOERROR | RXSETUP | RX_DATA_BK0 | TXCOMP |

WARNING: Due to synchronization between MCK and UDPCK, the software application must wait for the end of the write operation before executing another write by polling the bits which must be set/cleared.

```

//! Clear flags of UDP UDP_CSR register and waits for synchronization
#define Udp_ep_clr_flag(pInterface, endpoint, flags) { \
    pInterface->UDP_CSR[endpoint] &= ~(flags); \
    while ( (pInterface->UDP_CSR[endpoint] & (flags)) == (flags) ); \
}
//! Set flags of UDP UDP_CSR register and waits for synchronization
#define Udp_ep_set_flag(pInterface, endpoint, flags) { \
    pInterface->UDP_CSR[endpoint] |= (flags); \
    while ( (pInterface->UDP_CSR[endpoint] & (flags)) != (flags) ); \
}

```

Note: In a preemptive environment, set or clear the flag and wait for a time of 1 UDPCK clock cycle and 1 peripheral clock cycle. However, RX_DATA_BK0, TXPKTRDY, RX_DATA_BK1 require wait times of 3 UDPCK clock cycles and 3 peripheral clock cycles before accessing DPR.

- **TXCOMP: Generates an IN Packet with Data Previously Written in the DPR**

This flag generates an interrupt while it is set to one.

Write (Cleared by the firmware):

0: Clear the flag, clear the interrupt.

1: No effect.

Read (Set by the USB peripheral):

0: Data IN transaction has not been acknowledged by the Host.

1: Data IN transaction is achieved, acknowledged by the Host.

After having issued a Data IN transaction setting TXPKTRDY, the device firmware waits for TXCOMP to be sure that the host has acknowledged the transaction.

- **RX_DATA_BK0: Receive Data Bank 0**

This flag generates an interrupt while it is set to one.

Write (Cleared by the firmware):

0: Notify USB peripheral device that data have been read in the FIFO's Bank 0.

1: To leave the read value unchanged.

Read (Set by the USB peripheral):

0: No data packet has been received in the FIFO's Bank 0.

1: A data packet has been received, it has been stored in the FIFO's Bank 0.

When the device firmware has polled this bit or has been interrupted by this signal, it must transfer data from the FIFO to the microcontroller memory. The number of bytes received is available in RXBYTCENT field. Bank 0 FIFO values are read through the UDP_FDRx. Once a transfer is done, the device firmware must release Bank 0 to the USB peripheral device by clearing RX_DATA_BK0.

After setting or clearing this bit, a wait time of 3 UDPCCK clock cycles and 3 peripheral clock cycles is required before accessing DPR.

- **RXSETUP: Received Setup**

This flag generates an interrupt while it is set to one.

Read:

0: No setup packet available.

1: A setup data packet has been sent by the host and is available in the FIFO.

Write:

0: Device firmware notifies the USB peripheral device that it has read the setup data in the FIFO.

1: No effect.

This flag is used to notify the USB device firmware that a valid Setup data packet has been sent by the host and successfully received by the USB device. The USB device firmware may transfer Setup data from the FIFO by reading the UDP_FDRx to the microcontroller memory. Once a transfer has been done, RXSETUP must be cleared by the device firmware.

Ensuing Data OUT transaction is not accepted while RXSETUP is set.

- **STALLSENT: Stall Sent (Control, Bulk Interrupt Endpoints)/ISOERROR (Isochronous Endpoints)**

This flag generates an interrupt while it is set to one.

STALLSENT: This ends a STALL handshake.

Read:

0: The host has not acknowledged a STALL.

1: Host has acknowledged the stall.

Write:

0: Resets the STALLSENT flag, clears the interrupt.

1: No effect.

This is mandatory for the device firmware to clear this flag. Otherwise the interrupt remains.

Refer to chapters 8.4.5 and 9.4.5 of the *Universal Serial Bus Specification, Rev. 2.0* for more information on the STALL handshake.

ISOERROR: A CRC error has been detected in an isochronous transfer.

Read:

0: No error in the previous isochronous transfer.

1: CRC error has been detected, data available in the FIFO are corrupted.

Write:

0: Resets the ISOERROR flag, clears the interrupt.

1: No effect.

- **TXPKTRDY: Transmit Packet Ready**

This flag is cleared by the USB device.

This flag is set by the USB device firmware.

Read:

0: There is no data to send.

1: The data is waiting to be sent upon reception of token IN.

Write:

0: Can be used in the procedure to cancel transmission data. (See [Section 36.6.2.9 “Transmit Data Cancellation” on page 598.](#))

1: A new data payload has been written in the FIFO by the firmware and is ready to be sent.

This flag is used to generate a Data IN transaction (device to host). Device firmware checks that it can write a data payload in the FIFO, checking that TXPKTRDY is cleared. Transfer to the FIFO is done by writing in the UDP_FDRx. Once the data payload has been transferred to the FIFO, the firmware notifies the USB device setting TXPKTRDY to one. USB bus transactions can start. TXCOMP is set once the data payload has been received by the host.

After setting or clearing this bit, a wait time of 3 UDPCCK clock cycles and 3 peripheral clock cycles is required before accessing DPR.

- **FORCESTALL: Force Stall (used by Control, Bulk and Isochronous Endpoints)**

Read:

0: Normal state.

1: Stall state.

Write:

0: Return to normal state.

1: Send STALL to the host.

Refer to chapters 8.4.5 and 9.4.5 of the *Universal Serial Bus Specification, Rev. 2.0* for more information on the STALL handshake.

Control endpoints: During the data stage and status stage, this bit indicates that the microcontroller cannot complete the request.

Bulk and interrupt endpoints: This bit notifies the host that the endpoint is halted.

The host acknowledges the STALL, device firmware is notified by the STALLSENT flag.

- **RX_DATA_BK1: Receive Data Bank 1 (only used by endpoints with ping-pong attributes)**

This flag generates an interrupt while it is set to one.

Write (Cleared by the firmware):

0: Notifies USB device that data have been read in the FIFO's Bank 1.

1: To leave the read value unchanged.

Read (Set by the USB peripheral):

0: No data packet has been received in the FIFO's Bank 1.

1: A data packet has been received, it has been stored in FIFO's Bank 1.

When the device firmware has polled this bit or has been interrupted by this signal, it must transfer data from the FIFO to microcontroller memory. The number of bytes received is available in RXBYTECNT field. Bank 1 FIFO values are read through UDP_FDRx. Once a transfer is done, the device firmware must release Bank 1 to the USB device by clearing RX_DATA_BK1.

After setting or clearing this bit, a wait time of 3 UDPCCK clock cycles and 3 peripheral clock cycles is required before accessing DPR.

- **DIR: Transfer Direction (only available for control endpoints)**

Read/Write

0: Allows Data OUT transactions in the control data stage.

1: Enables Data IN transactions in the control data stage.

Refer to Chapter 8.5.3 of the *Universal Serial Bus Specification, Rev. 2.0* for more information on the control data stage.

This bit must be set before UDP_CSRx/RXSETUP is cleared at the end of the setup stage. According to the request sent in the setup data packet, the data stage is either a device to host (DIR = 1) or host to device (DIR = 0) data transfer. It is not necessary to check this bit to reverse direction for the status stage.

- **EPTYPE[2:0]: Endpoint Type**

Read/Write

| | |
|-----|-----------------|
| 000 | Control |
| 001 | Isochronous OUT |
| 101 | Isochronous IN |
| 010 | Bulk OUT |
| 110 | Bulk IN |
| 011 | Interrupt OUT |
| 111 | Interrupt IN |

- **DTGLE: Data Toggle**

Read-only

0: Identifies DATA0 packet.

1: Identifies DATA1 packet.

Refer to Chapter 8 of the *Universal Serial Bus Specification, Rev. 2.0* for more information on DATA0, DATA1 packet definitions.

- **EPEDS: Endpoint Enable Disable**

Read:

0: Endpoint disabled.

1: Endpoint enabled.

Write:

0: Disables endpoint.

1: Enables endpoint.

Control endpoints are always enabled. Reading or writing this field has no effect on control endpoints.

Note: After reset, all endpoints are configured as control endpoints (zero).

- **RXBYTECNT[10:0]: Number of Bytes Available in the FIFO**

Read-only

When the host sends a data packet to the device, the USB device stores the data in the FIFO and notifies the microcontroller. The microcontroller can load the data from the FIFO by reading RXBYTECENT bytes in the UDP_FDRx.

36.7.11 UDP FIFO Data Register

Name: UDP_FDRx [x = 0..5]

Address: 0xFFFA404C

Access: Read/Write

| | | | | | | | |
|-----------|----|----|----|----|----|----|----|
| 31 | 30 | 29 | 28 | 27 | 26 | 25 | 24 |
| – | – | – | – | – | – | – | – |
| 23 | 22 | 21 | 20 | 19 | 18 | 17 | 16 |
| – | – | – | – | – | – | – | – |
| 15 | 14 | 13 | 12 | 11 | 10 | 9 | 8 |
| – | – | – | – | – | – | – | – |
| 7 | 6 | 5 | 4 | 3 | 2 | 1 | 0 |
| FIFO_DATA | | | | | | | |

- **FIFO_DATA[7:0]: FIFO Data Value**

The microcontroller can push or pop values in the FIFO through this register.

RXBYTECNT in the corresponding UDP_CSRx is the number of bytes to be read from the FIFO (sent by the host).

The maximum number of bytes to write is fixed by the Max Packet Size in the Standard Endpoint Descriptor. It can not be more than the physical memory size associated to the endpoint. Refer to the *Universal Serial Bus Specification, Rev. 2.0* for more information.

36.7.12 UDP Transceiver Control Register

Name: UDP_TXVC

Address: 0xFFFFA4074

Access: Read/Write

| | | | | | | | |
|----|----|----|----|----|----|----|--------|
| 31 | 30 | 29 | 28 | 27 | 26 | 25 | 24 |
| – | – | – | – | – | – | – | – |
| 23 | 22 | 21 | 20 | 19 | 18 | 17 | 16 |
| – | – | – | – | – | – | – | – |
| 15 | 14 | 13 | 12 | 11 | 10 | 9 | 8 |
| – | – | – | – | – | – | – | TXVDIS |
| 7 | 6 | 5 | 4 | 3 | 2 | 1 | 0 |
| – | – | – | – | – | – | – | – |

WARNING: The UDP peripheral clock in the Power Management Controller (PMC) must be enabled before any read/write operations to the UDP registers including the UDP_TXVC register.

- **TXVDIS: Transceiver Disable**

When UDP is disabled, power consumption can be reduced significantly by disabling the embedded transceiver. This can be done by setting TXVDIS field.

To enable the transceiver, TXVDIS must be cleared.

NOTE: If the USB pullup is not connected on DP, the user should not write in any UDP register other than the UDP_TXVC register. This is because if DP and DM are floating at 0, or pulled down, then SE0 is received by the device with the consequence of a USB Reset.

37. LCD Controller (LCDC)

37.1 Overview

The LCD Controller (LCDC) consists of logic for transferring LCD image data from an external display buffer to an LCD module with integrated common and segment drivers.

The LCD Controller supports single and double scan monochrome and color passive STN LCD modules and single scan active TFT LCD modules. On monochrome STN displays, up to 16 gray shades are supported using a time-based dithering algorithm and Frame Rate Control (FRC) method. This method is also used in color STN displays to generate up to 4096 colors.

The LCD Controller has a display input buffer (FIFO) to allow a flexible connection of the external AHB master interface, and a lookup table to allow palletized display configurations.

The LCD Controller is programmable in order to support many different requirements such as resolutions up to 2048 x 2048; pixel depth (1, 2, 4, 8, 16, 24 bits per pixel); data line width (4, 8, 16 or 24 bits) and interface timing.

The LCD Controller is connected to the ARM Advanced High Performance Bus (AHB) as a master for reading pixel data. However, the LCD Controller interfaces with the AHB as a slave in order to configure its registers.

37.2 Block Diagram

Figure 37-1. LCD Macrocell Block Diagram

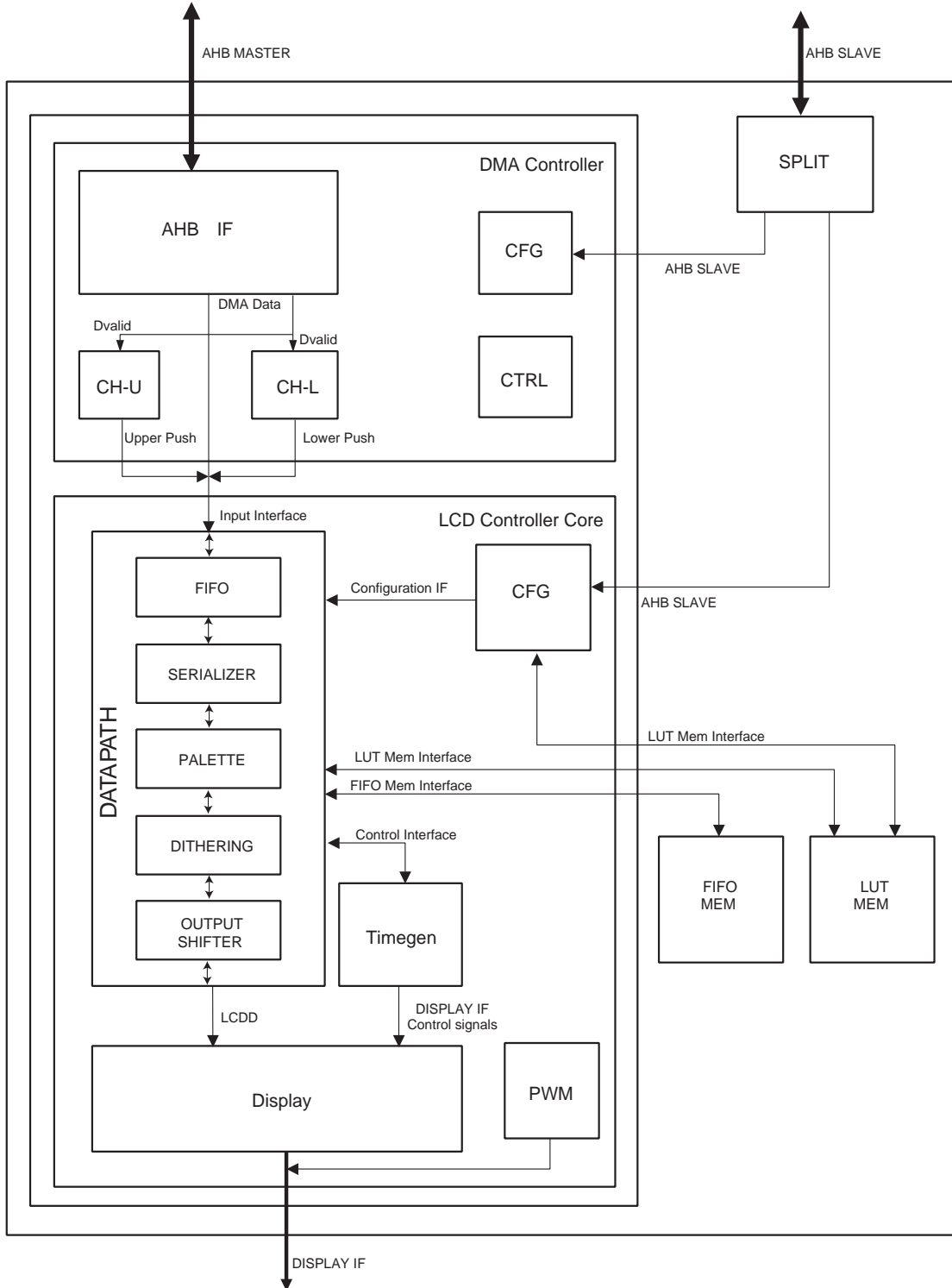

37.3 I/O Lines Description

Table 37-1. I/O Lines Description

| Name | Description | Type |
|------------|---|--------|
| LCDDC | Contrast control signal | Output |
| LCDHSYNC | Line synchronous signal (STN) or Horizontal synchronous signal (TFT) | Output |
| LCDDOTCK | LCD clock signal (STN/TFT) | Output |
| LCDVSYNC | Frame synchronous signal (STN) or Vertical synchronization signal (TFT) | Output |
| LCDDEN | Data enable signal | Output |
| LCDD[23:0] | LCD Data Bus output | Output |

37.4 Product Dependencies

37.4.1 I/O Lines

The pins used for interfacing the LCD Controller may be multiplexed with PIO lines. The programmer must first program the PIO Controller to assign the pins to their peripheral function. If I/O lines of the LCD Controller are not used by the application, they can be used for other purposes by the PIO Controller.

37.4.2 Power Management

The LCD Controller is not continuously clocked. As the LCD Controller is on the AHB bus, the clock is enabled by setting the HCKx bit in the PMC_SCER.

37.4.3 Interrupt Sources

The LCD Controller interrupt line is connected to one of the internal sources of the Advanced Interrupt Controller. Using the LCD Controller interrupt requires prior programming of the AIC.

37.5 Functional Description

The LCD Controller consists of two main blocks ([Figure 37-1 on page 622](#)), the DMA controller and the LCD controller core (LCDC core). The DMA controller reads the display data from an external memory through a AHB master interface. The LCD controller core formats the display data. The LCD controller core continuously pumps the pixel data into the LCD module via the LCD data bus (LCDD[23:0]); this bus is timed by the LCDDOTCK, LCDDEN, LCDHSYNC, and LCDVSYNC signals.

37.5.1 DMA Controller

37.5.1.1 Configuration Block

The configuration block is a set of programmable registers that are used to configure the DMA controller operation. These registers are written via the AHB slave interface. Only word access is allowed.

For details on the configuration registers, see [“LCD Controller \(LCDC\) User Interface” on page 644](#).

37.5.1.2 AHB Interface

This block generates the AHB transactions. It generates undefined-length incrementing bursts as well as 4-, 8- or 16-beat incrementing bursts. The size of the transfer can be configured in the BRSTLN field of the DMAFRMCFG register. For details on this register, see [“DMA Frame Configuration Register” on page 651](#).

37.5.1.3 Channel-U

This block stores the base address and the number of words transferred for this channel (frame in single scan mode and Upper Panel in dual scan mode) since the beginning of the frame. It also generates the end of frame signal.

It has two pointers, the base address and the number of words to transfer. When the module receives a new_frame signal, it reloads the number of words to transfer pointer with the size of the frame/panel. When the module receives the new_frame signal, it also reloads the base address with the base address programmed by the host.

The size of the frame/panel can be programmed in the FRMSIZE field of the DMAFRMCFG Register. This size is calculated as follows:

$$\text{Frame_size} = \left\lceil \frac{\text{Display_size} \times \text{Bpp}}{32} \right\rceil$$

where:

- Display_size = Horizontal_display_size x Vertical_display_size
- Bpp is the bits per pixel configuration

37.5.1.4 Channel-L

This block has the same functionality as Channel-U, but for the Lower Panel in dual scan mode only.

37.5.1.5 Control

This block receives the request signals from the LCDC core and generates the requests for the channels.

37.5.2 LCD Controller Core

37.5.2.1 Configuration Block

The configuration block is a set of programmable registers that are used to configure the LCDC core operation. These registers are written via the AHB slave interface. Only word access is allowed.

The description of the configuration registers can be found in [“LCD Controller \(LCDC\) User Interface” on page 644](#).

37.5.2.2 Datapath

The datapath block contains five submodules: FIFO, Serializer, Palette, Dithering and Shifter. The structure of the datapath is shown in [Figure 37-2](#).

Figure 37-2. Datapath Structure

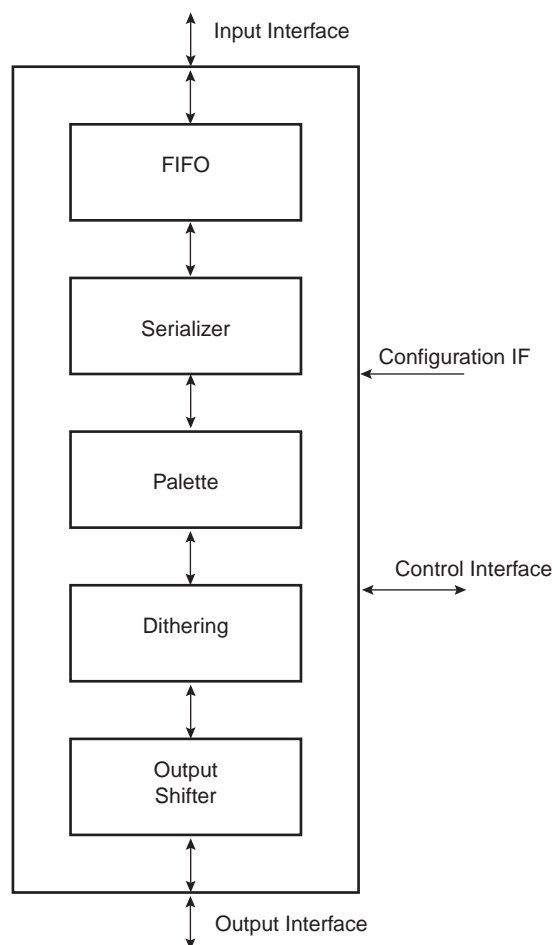

This module transforms the data read from the memory into a format according to the LCD module used. It has four different interfaces: the input interface, the output interface, the configuration interface and the control interface.

- The input interface connects the datapath with the DMA controller. It is a dual FIFO interface with a data bus and two push lines that are used by the DMA controller to fill the FIFOs.
- The output interface is a 24-bit data bus. The configuration of this interface depends on the type of LCD used (TFT or STN, Single or Dual Scan, 4-bit, 8-bit, 16-bit or 24-bit interface).
- The configuration interface connects the datapath with the configuration block. It is used to select between the different datapath configurations.
- The control interface connects the datapath with the timing generation block. The main control signal is the data-request signal, used by the timing generation module to request new data from the datapath.

The datapath can be characterized by two parameters: `initial_latency` and `cycles_per_data`. The parameter `initial_latency` is defined as the number of LCDC Core Clock cycles until the first data is available at the output of the datapath. The parameter `cycles_per_data` is the minimum number of LCDC Core clock cycles between two consecutive data at the output interface.

These parameters are different for the different configurations of the LCD Controller and are shown in [Table 37-2](#).

Table 37-2. Datapath Parameters

| Configuration | | | initial_latency | cycles_per_data |
|---------------|--------|----------------|-----------------|-----------------|
| DISTYPE | SCAN | IFWIDTH | | |
| TFT | Single | Not applicable | 9 | 1 |
| STN Mono | Single | 4 | 13 | 4 |
| STN Mono | Single | 8 | 17 | 8 |
| STN Mono | Dual | 8 | 17 | 8 |
| STN Mono | Dual | 16 | 25 | 16 |
| STN Color | Single | 4 | 11 | 2 |
| STN Color | Single | 8 | 12 | 3 |
| STN Color | Dual | 8 | 14 | 4 |
| STN Color | Dual | 16 | 15 | 6 |

37.5.2.3 FIFO

The FIFO block buffers the input data read by the DMA module. It contains two input FIFOs to be used in Dual Scan configuration that are configured as a single FIFO when used in single scan configuration.

The size of the FIFOs allows a wide range of architectures to be supported.

The upper threshold of the FIFOs can be configured in the FIFOTH field of the LCDFIFO register. The LCDC core will request a DMA transfer when the number of words in each FIFO is less than FIFOTH words. To avoid overwriting in the FIFO and to maximize the FIFO utilization, the FIFOTH should be programmed with:

$$\text{FIFOTH} = 512 - (2 \times \text{DMA_BURST_LENGTH} + 3)$$

where:

- 512 is the effective size of the FIFO. It is the total FIFO memory size in single scan mode and half that size in dual scan mode.
- DMA_burst_length is the burst length of the transfers made by the DMA

37.5.2.4 Serializer

This block serializes the data read from memory. It reads words from the FIFO and outputs pixels (1 bit, 2 bits, 4 bits, 8 bits, 16 bits or 24 bits wide) depending on the format specified in the PIXELSIZE field of the LCDCON2 register. It also adapts the memory-ordering format. Both big-endian and little-endian formats are supported. They are configured in the MEMOR field of the LCDCON2 register.

The organization of the pixel data in the memory depends on the configuration and is shown in [Table 37-3](#) and [Table 37-4](#).

Table 37-3. Little Endian Memory Organization

| Mem Addr | 0x3 | | | | | | | | 0x2 | | | | | | | | 0x1 | | | | | | | | 0x0 | | | | | | | |
|-------------|-----|----|----|----|----|----|----|----|-----|----|----|----|----|----|----|----|-----|----|----|----|----|----|---|---|-----|---|---|---|---|---|---|---|
| Bit | 31 | 30 | 29 | 28 | 27 | 26 | 25 | 24 | 23 | 22 | 21 | 20 | 19 | 18 | 17 | 16 | 15 | 14 | 13 | 12 | 11 | 10 | 9 | 8 | 7 | 6 | 5 | 4 | 3 | 2 | 1 | 0 |
| Pixel 1bpp | 31 | 30 | 29 | 28 | 27 | 26 | 25 | 24 | 23 | 22 | 21 | 20 | 19 | 18 | 17 | 16 | 15 | 14 | 13 | 12 | 11 | 10 | 9 | 8 | 7 | 6 | 5 | 4 | 3 | 2 | 1 | 0 |
| Pixel 2bpp | 15 | | 14 | | 13 | | 12 | | 11 | | 10 | | 9 | | 8 | | 7 | | 6 | | 5 | | 4 | | 3 | | 2 | | 1 | | 0 | |
| Pixel 4bpp | 7 | | | | 6 | | | | 5 | | | | 4 | | | | 3 | | | | 2 | | | | 1 | | | | 0 | | | |
| Pixel 8bpp | 3 | | | | | | | | 2 | | | | | | | | 1 | | | | | | | | 0 | | | | | | | |
| Pixel 16bpp | 1 | | | | | | | | | | | | | | | | 0 | | | | | | | | | | | | | | | |
| Pixel 24bpp | 1 | | | | | | | | 0 | | | | | | | | | | | | | | | | | | | | | | | |
| Pixel 24bpp | 2 | | | | | | | | | | | | | | | | 1 | | | | | | | | | | | | | | | |
| Pixel 24bpp | 3 | | | | | | | | | | | | | | | | 2 | | | | | | | | | | | | | | | |
| Pixel 24bpp | 5 | | | | | | | | 4 | | | | | | | | | | | | | | | | | | | | | | | |

Table 37-4. Big Endian Memory Organization

| Mem Addr | 0x3 | | | | | | | | 0x2 | | | | | | | | 0x1 | | | | | | | | 0x0 | | | | | | | |
|-------------|-----|----|----|----|----|----|----|----|-----|----|----|----|----|----|----|----|-----|----|----|----|----|----|----|----|-----|----|----|----|----|----|----|----|
| Bit | 31 | 30 | 29 | 28 | 27 | 26 | 25 | 24 | 23 | 22 | 21 | 20 | 19 | 18 | 17 | 16 | 15 | 14 | 13 | 12 | 11 | 10 | 9 | 8 | 7 | 6 | 5 | 4 | 3 | 2 | 1 | 0 |
| Pixel 1bpp | 0 | 1 | 2 | 3 | 4 | 5 | 6 | 7 | 8 | 9 | 10 | 11 | 12 | 13 | 14 | 15 | 16 | 17 | 18 | 19 | 20 | 21 | 22 | 23 | 24 | 25 | 26 | 27 | 28 | 29 | 30 | 31 |
| Pixel 2bpp | 0 | | 1 | | 2 | | 3 | | 4 | | 5 | | 6 | | 7 | | 8 | | 9 | | 10 | | 11 | | 12 | | 13 | | 14 | | 15 | |
| Pixel 4bpp | 0 | | | | 1 | | | | 2 | | | | 3 | | | | 4 | | | | 5 | | | | 6 | | | | 7 | | | |
| Pixel 8bpp | 0 | | | | | | | | 1 | | | | | | | | 2 | | | | | | | | 3 | | | | | | | |
| Pixel 16bpp | 0 | | | | | | | | | | | | | | | | 1 | | | | | | | | | | | | | | | |
| Pixel 24bpp | 0 | | | | | | | | | | | | | | | | 1 | | | | | | | | | | | | | | | |
| Pixel 24bpp | 1 | | | | | | | | | | | | | | | | 2 | | | | | | | | | | | | | | | |
| Pixel 24bpp | 2 | | | | | | | | 3 | | | | | | | | | | | | | | | | | | | | | | | |
| Pixel 24bpp | 4 | | | | | | | | | | | | | | | | 5 | | | | | | | | | | | | | | | |

37.5.2.5 Palette

This block is used to generate the pixel gray or color information in palletized configurations. The different modes with the palletized/non-palletized configuration can be found in [Table 37-5](#). In these modes, 1, 2, 4 or 8 input bits index an entry in the lookup table. The corresponding entry in the lookup table contains the color or gray shade information for the pixel.

Table 37-5. Palette Configurations

| Configuration | | Palette |
|---------------|------------|----------------|
| DISTYPE | PIXELSIZE | |
| TFT | 1, 2, 4, 8 | Palletized |
| TFT | 16, 24 | Non-palletized |
| STN Mono | 1, 2 | Palletized |
| STN Mono | 4 | Non-palletized |
| STN Color | 1, 2, 4, 8 | Palletized |
| STN Color | 16 | Non-palletized |

The lookup table can be accessed by the host in R/W mode to allow the host to program and check the values stored in the palette. It is mapped in the LCD controller configuration memory map. The LUT is mapped as 16-bit half-words aligned at word boundaries, only word write access is allowed (the 16 MSB of the bus are not used). For the detailed memory map, see [Table 37-12 on page 644](#).

The lookup table contains 256 16-bit wide entries. The 256 entries are chosen by the programmer from the 2^{16} possible combinations.

For the structure of each LUT entry, see [Table 37-6](#).

Table 37-6. Lookup Table Structure in the Memory

| Address | Data Output [15:0] | | | |
|---------|--------------------|---------------------|----------------------|--------------------|
| 00 | Intensity_bit_0 | Blue_value_0[4:0] | Green_value_0[4:0] | Red_value_0[4:0] |
| 01 | Intensity_bit_1 | Blue_value_1[4:0] | Green_value_1[4:0] | Red_value_1[4:0] |
| ... | | | | |
| FE | Intensity_bit_254 | Blue_value_254[4:0] | Green_value_254[4:0] | Red_value_254[4:0] |
| FF | Intensity_bit_255 | Blue_value_255[4:0] | Green_value_255[4:0] | Red_value_255[4:0] |

In STN Monochrome, only the four most significant bits of the red value are used (16 gray shades). In STN Color, only the four most significant bits of the blue, green and red value are used (4096 colors).

In TFT mode, all the bits in the blue, green and red values are used (32768 colors). In this mode, there is also a common intensity bit that can be used to double the possible colors. This bit is the least significant bit of each color component in the LCDD interface (LCDD[18], LCDD[10], LCDD[2]). The LCDD unused bits are tied to 0 when TFT palletized configurations are used (LCDD[17:16], LCDD[9:8], LCDD[1:0]).

37.5.2.6 Dithering

The dithering block is used to generate the shades of gray or color when the LCD Controller is used with an STN LCD Module. It uses a time-based dithering algorithm and Frame Rate Control method.

The Frame Rate Control varies the duty cycle for which a given pixel is turned on, giving the display an appearance of multiple shades. In order to reduce the flicker noise caused by turning on and off adjacent pixels at the same time, a time-based dithering algorithm is used to vary the pattern of adjacent pixels every frame. This algorithm is expressed in terms of Dithering Pattern registers (DP_i) and considers not only the pixel gray level number, but also its horizontal coordinate.

[Table 37-7](#) shows the correspondences between the gray levels and the duty cycle.

Table 37-7. Dithering Duty Cycle

| Gray Level | Duty Cycle | Pattern Register |
|------------|------------|------------------|
| 15 | 1 | - |
| 14 | 6/7 | DP6_7 |
| 13 | 4/5 | DP4_5 |
| 12 | 3/4 | DP3_4 |
| 11 | 5/7 | DP5_7 |
| 10 | 2/3 | DP2_3 |
| 9 | 3/5 | DP3_5 |
| 8 | 4/7 | DP4_7 |
| 7 | 1/2 | ~DP1_2 |
| 6 | 3/7 | ~DP4_7 |
| 5 | 2/5 | ~DP3_5 |
| 4 | 1/3 | ~DP2_3 |
| 3 | 1/4 | ~DP3_4 |
| 2 | 1/5 | ~DP4_5 |
| 1 | 1/7 | ~DP6_7 |
| 0 | 0 | - |

The duty cycles for gray levels 0 and 15 are 0 and 1, respectively.

The same DP_i register can be used for the pairs for which the sum of duty cycles is 1 (e.g., 1/7 and 6/7). The dithering pattern for the first pair member is the inversion of the one for the second.

The DP_i registers contain a series of 4-bit patterns. The (3-m)th bit of the pattern determines if a pixel with horizontal coordinate $x = 4n + m$ (n is an integer and m ranges from 0 to 3) should be turned on or off in the current frame. The operation is shown by the examples below.

Consider the pixels a, b, c and d with the horizontal coordinates $4*n+0$, $4*n+1$, $4*n+2$ and $4*n+3$, respectively. The four pixels should be displayed in gray level 9 (duty cycle 3/5) so the register used is DP3_5 = "1010 0101 1010 0101 1111".

The output sequence obtained in the data output for monochrome mode is shown in [Table 37-8](#).

Table 37-8. Dithering Algorithm for Monochrome Mode

| Frame Number | Pattern | Pixel a | Pixel b | Pixel c | Pixel d |
|--------------|---------|---------|---------|---------|---------|
| N | 1010 | ON | OFF | ON | OFF |
| N+1 | 0101 | OFF | ON | OFF | ON |
| N+2 | 1010 | ON | OFF | ON | OFF |
| N+3 | 0101 | OFF | ON | OFF | ON |
| N+4 | 1111 | ON | ON | ON | ON |
| N+5 | 1010 | ON | OFF | ON | OFF |
| N+6 | 0101 | OFF | ON | OFF | ON |
| N+7 | 1010 | ON | OFF | ON | OFF |
| ... | ... | ... | ... | ... | ... |

Consider now color display mode and two pixels p0 and p1 with the horizontal coordinates $4*n+0$, and $4*n+1$. A color pixel is composed of three components: {R, G, B}. Pixel p0 will be displayed sending the color components {R0, G0, B0} to the display. Pixel p1 will be displayed sending the color components {R1, G1, B1}. Suppose that the data read from memory and mapped to the lookup tables corresponds to shade level 10 for the three color components of both pixels, with the dithering pattern to apply to all of them being DP2_3 = “1101 1011 0110”. [Table 37-9](#) shows the output sequence in the data output bus for single scan configurations. (In Dual Scan Configuration, each panel data bus acts like in the equivalent single scan configuration.)

Table 37-9. Dithering Algorithm for Color Mode

| Frame | Signal | Shadow Level | Bit used | Dithering Pattern | 4-bit LCDD | 8-bit LCDD | Output |
|-------|--------------|--------------|----------|-------------------|------------|------------|--------|
| N | red_data_0 | 1010 | 3 | 1101 | LCDD[3] | LCDD[7] | R0 |
| N | green_data_0 | 1010 | 2 | 1101 | LCDD[2] | LCDD[6] | G0 |
| N | blue_data_0 | 1010 | 1 | 1101 | LCDD[1] | LCDD[5] | b0 |
| N | red_data_1 | 1010 | 0 | 1101 | LCDD[0] | LCDD[4] | R1 |
| N | green_data_1 | 1010 | 3 | 1101 | LCDD[3] | LCDD[3] | G1 |
| N | blue_data_1 | 1010 | 2 | 1101 | LCDD[2] | LCDD[2] | B1 |
| ... | ... | ... | ... | ... | ... | ... | ... |
| N+1 | red_data_0 | 1010 | 3 | 1011 | LCDD[3] | LCDD[7] | R0 |
| N+1 | green_data_0 | 1010 | 2 | 1011 | LCDD[2] | LCDD[6] | g0 |
| N+1 | blue_data_0 | 1010 | 1 | 1011 | LCDD[1] | LCDD[5] | B0 |
| N+1 | red_data_1 | 1010 | 0 | 1011 | LCDD[0] | LCDD[4] | R1 |
| N+1 | green_data_1 | 1010 | 3 | 1011 | LCDD[3] | LCDD[3] | G1 |
| N+1 | blue_data_1 | 1010 | 2 | 1011 | LCDD[2] | LCDD[2] | b1 |
| ... | ... | ... | ... | ... | ... | ... | ... |
| N+2 | red_data_0 | 1010 | 3 | 0110 | LCDD[3] | LCDD[7] | r0 |
| N+2 | green_data_0 | 1010 | 2 | 0110 | LCDD[2] | LCDD[6] | G0 |
| N+2 | blue_data_0 | 1010 | 1 | 0110 | LCDD[1] | LCDD[5] | B0 |
| N+2 | red_data_1 | 1010 | 0 | 0110 | LCDD[0] | LCDD[4] | r1 |

Table 37-9. Dithering Algorithm for Color Mode (Continued)

| Frame | Signal | Shadow Level | Bit used | Dithering Pattern | 4-bit LCDD | 8-bit LCDD | Output |
|-------|--------------|--------------|----------|-------------------|------------|------------|--------|
| N+2 | green_data_1 | 1010 | 3 | 0110 | LCDD[3] | LCDD[3] | g1 |
| N+2 | blue_data_1 | 1010 | 2 | 0110 | LCDD[2] | LCDD[2] | B1 |
| ... | ... | ... | ... | ... | ... | ... | ... |

Note: Ri = red pixel component ON. Gi = green pixel component ON. Bi = blue pixel component ON. ri = red pixel component OFF. gi = green pixel component OFF. bi = blue pixel component OFF.

37.5.2.7 Shifter

The FIFO, Serializer, Palette and Dithering modules process one pixel at a time in monochrome mode and three sub-pixels at a time in color mode (R,G,B components). This module packs the data according to the output interface. This interface can be programmed in the DISTYPE, SCANMOD, and IFWIDTH fields of the LCDCON2 register.

The DISTYPE field selects between TFT, STN monochrome and STN color display. The SCANMODE field selects between single and dual scan modes; in TFT mode, only single scan is supported. The IFWIDTH field configures the width of the interface in STN mode: 4-bit (in single scan mode only), 8-bit and 16-bit (in dual scan mode only).

For a more detailed description of the fields, see [“LCD Controller \(LCDC\) User Interface” on page 644](#).

For a more detailed description of the LCD Interface, see [“LCD Interface” on page 636](#).

37.5.2.8 Timegen

The time generator block generates the control signals LCDDOTCK, LCDHSYNC, LCDVSYNC, LCDDEN, used by the LCD module. This block is programmable in order to support different types of LCD modules and obtain the output clock signals, which are derived from the LCDC Core clock.

The LCDDOTCK signal is used to clock the data into the LCD drivers' shift register. The data is sent through LCDD[23:0] synchronized by default with LCDDOTCK falling edge (rising edge can be selected). The CLKVAL field of LCDCON1 register controls the rate of this signal. The divisor can also be bypassed with the BYPASS bit in the LCDCON1 register. In this case, the rate of LCDDOTCK is equal to the frequency of the LCDC Core clock. The minimum period of the LCDDOTCK signal depends on the configuration. This information can be found in [Table 37-10](#).

$$f_{\text{LCDDOTCK}} = \frac{f_{\text{LCDC_clock}}}{2 \times \text{CLKVAL}}$$

The LCDDOTCK signal has two different timings that are selected with the CLKMOD field of the LCDCON2 register:

- Always Active (used with TFT LCD Modules)
- Active only when data is available (used with STN LCD Modules)

Table 37-10. Minimum LCDDOTCK Period in LCDC Core Clock Cycles

| Configuration | | | LCDDOTCK Period |
|---------------|--------|----------------|-----------------|
| DISTYPE | SCAN | IFWIDTH | |
| TFT | Single | Not applicable | 1 |
| STN Mono | Single | 4 | 4 |
| STN Mono | Single | 8 | 8 |
| STN Mono | Dual | 8 | 8 |
| STN Mono | Dual | 16 | 16 |

Table 37-10. Minimum LCDDOTCK Period in LCDC Core Clock Cycles (Continued)

| Configuration | | | LCDDOTCK Period |
|---------------|--------|---------|-----------------|
| DISTYPE | SCAN | IFWIDTH | |
| STN Color | Single | 4 | 2 |
| STN Color | Single | 8 | 2 |
| STN Color | Dual | 8 | 4 |
| STN Color | Dual | 16 | 6 |

The LCDDEN signal indicates valid data in the LCD Interface.

After each horizontal line of data has been shifted into the LCD, the LCDHSYNC is asserted to cause the line to be displayed on the panel.

The following timing parameters can be configured:

- Vertical to Horizontal Delay (VHDLY): The delay between begin_of_line and the generation of LCDHSYNC is configurable in the VHDLY field of the LCDTIM1 register. The delay is equal to (VHDLY+1) LCDDOTCK cycles.
- Horizontal Pulse Width (HPW): The LCDHSYNC pulse width is configurable in HPW field of LCDTIM2 register. The width is equal to (HPW + 1) LCDDOTCK cycles.
- Horizontal Back Porch (HBP): The delay between the LCDHSYNC falling edge and the first LCDDOTCK rising edge with valid data at the LCD Interface is configurable in the HBP field of the LCDTIM2 register. The delay is equal to (HBP+1) LCDDOTCK cycles.
- Horizontal Front Porch (HFP): The delay between end of valid data and the end of the line is configurable in the HFP field of the LCDTIM2 register. The delay is equal to (HFP+2) LCDDOTCK cycles.

There is a limitation in the minimum values of VHDLY, HPW and HBP parameters imposed by the initial latency of the datapath. The total delay in LCDC clock cycles must be higher than or equal to the latency column in [Table 37-2 on page 626](#). This limitation is given by the following formula:

37.5.2.9 Equation 1

$$(VHDLY + HPW + HBP + 3) \times PCLK_PERIOD \geq DPATH_LATENCY$$

where:

- VHDLY, HPW, HBP are the value of the fields of LCDTIM1 and LCDTIM2 registers
- PCLK_PERIOD is the period of LCDDOTCK signal measured in LCDC Clock cycles
- DPATH_LATENCY is the datapath latency of the configuration, given in [Table 37-2 on page 626](#)

The LCDVSYNC is asserted once per frame. This signal is asserted to cause the LCD's line pointer to start over at the top of the display. The timing of this signal depends on the type of LCD: STN or TFT LCD.

In STN mode, the high phase corresponds to the complete first line of the frame. In STN mode, this signal is synchronized with the first active LCDDOTCK rising edge in a line.

In TFT mode, the high phase of this signal starts at the beginning of the first line. The following timing parameters can be selected:

- Vertical Pulse Width (VPW): LCDVSYNC pulse width is configurable in VPW field of the LCDTIM1 register. The pulse width is equal to (VPW+1) lines.
- Vertical Back Porch: Number of inactive lines at the beginning of the frame is configurable in VBP field of LCDTIM1 register. The number of inactive lines is equal to VBP. This field should be programmed with 0 in STN Mode.
- Vertical Front Porch: Number of inactive lines at the end of the frame is configurable in VFP field of LCDTIM2 register. The number of inactive lines is equal to VFP. This field should be programmed with 0 in STN mode.

There are two other parameters to configure in this module, the HOZVAL and the LINEVAL fields of the LCDFRMCFG:

- HOZVAL configures the number of active LCDDOTCK cycles in each line. The number of active cycles in each line is equal to (HOZVAL+1) cycles. The minimum value of this parameter is 1.
- LINEVAL configures the number of active lines per frame. This number is equal to (LINEVAL+1) lines. The minimum value of this parameter is 1.

Figure 37-3, Figure 37-4 and Figure 37-5 show the timing of LCDDOTCK, LCDDEN, LCDHSYNC and LCDVSYNC signals:

Figure 37-3. STN Panel Timing, CLKMOD 0

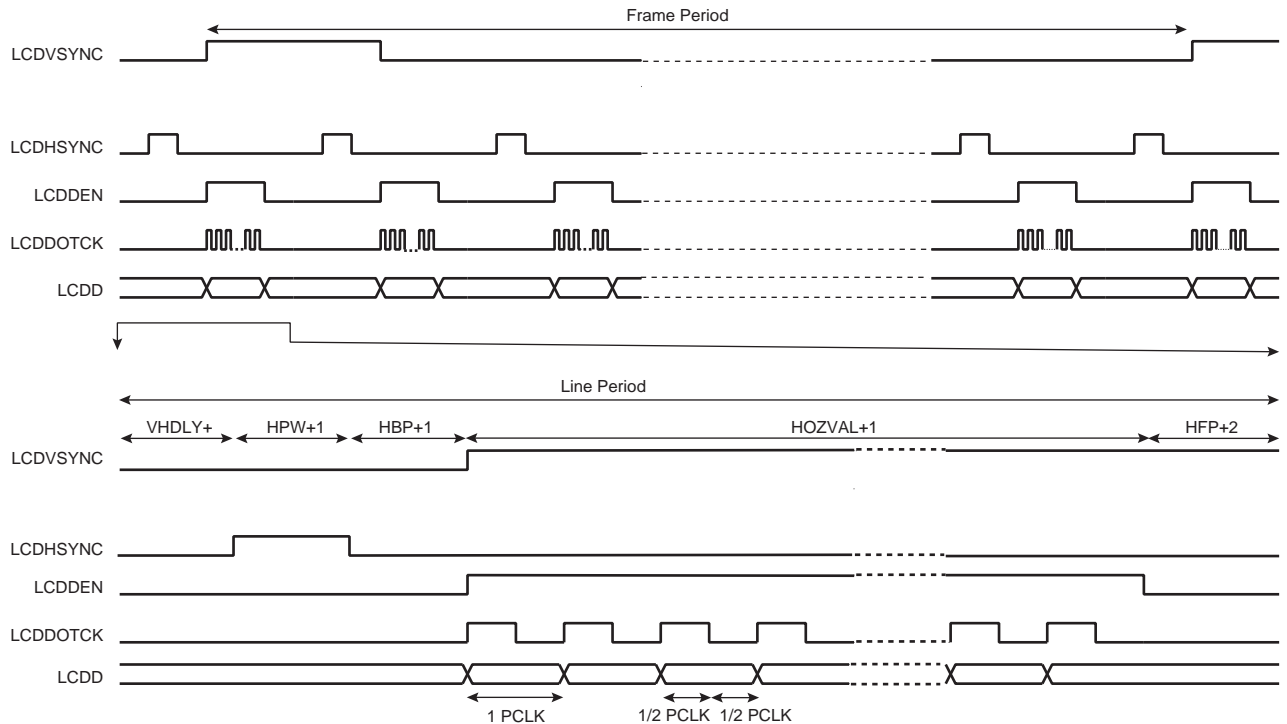

Figure 37-4. TFT Panel Timing, CLKMOD = 0, VPW = 2, VBP = 2, VFP = 1

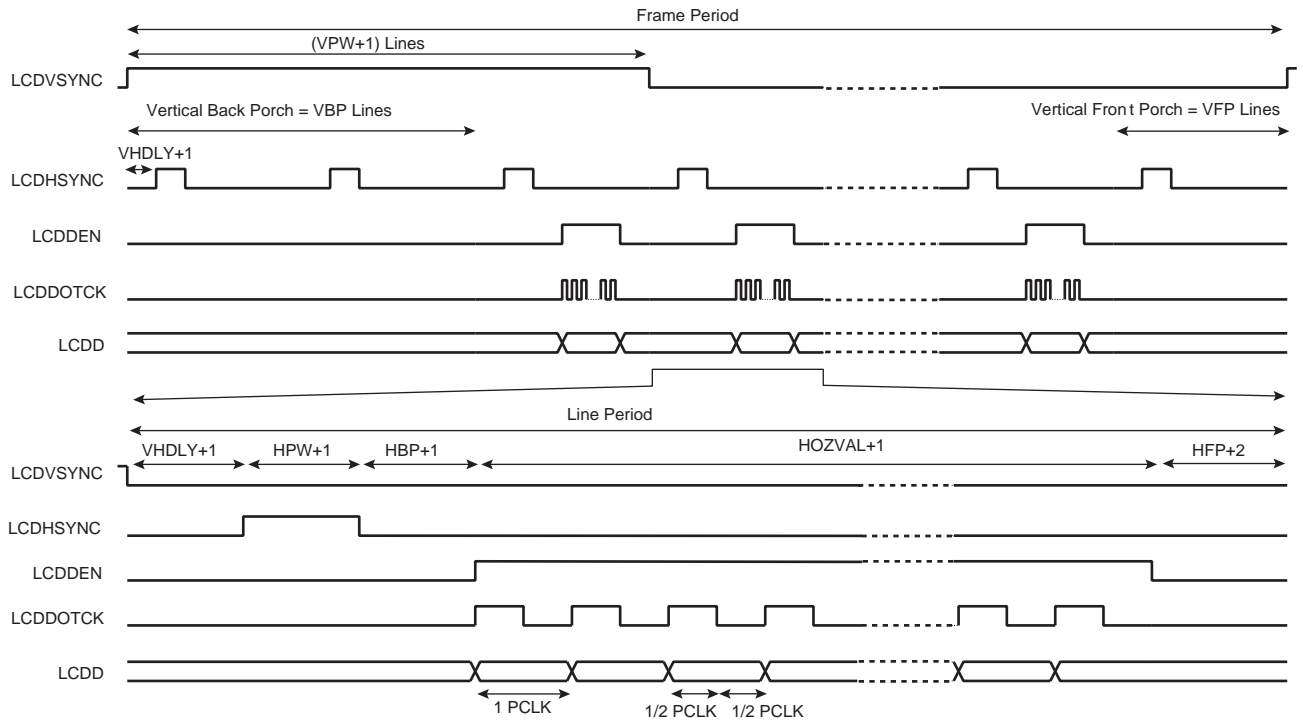
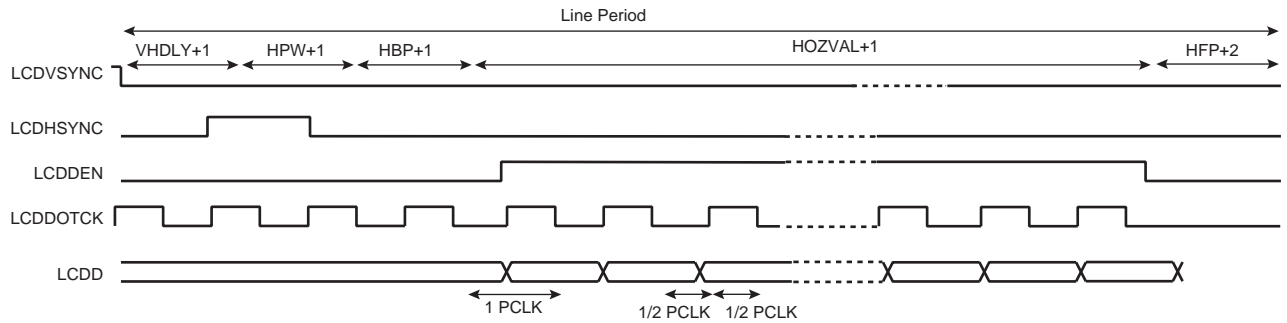

Figure 37-5. TFT Panel Timing (Line Expanded View), CLKMOD=1



Usually the LCD_FRM rate is about 70 Hz to 75 Hz. It is given by the following equation:

$$\frac{1}{f_{\text{LCDVSYNC}}} = \left(\frac{\text{VHDLY} + \text{HPW} + \text{HBP} + \text{HOZVAL} + \text{HFP} + 5}{f_{\text{LCDDOTCK}}} \right) (\text{VBP} + \text{LINEVAL} + \text{VFP} + 1)$$

where:

- HOZVAL determines the number of LCDDOTCK cycles per line
- LINEVAL determines the number of LCDHSYNC cycles per frame, according to the expressions shown below:

In STN Mode:

$$\text{HOZVAL} = \frac{\text{Horizontal_display_size}}{\text{Number_data_lines}} - 1$$

$$\text{LINEVAL} = \text{Vertical_display_size} - 1$$

In monochrome mode, Horizontal_display_size is equal to the number of horizontal pixels. The number_data_lines is equal to the number of bits of the interface in single scan mode; number_data_lines is equal to half the bits of the interface in dual scan mode.

In color mode, Horizontal_display_size equals three times the number of horizontal pixels.

In TFT Mode:

$$\text{HOZVAL} = \text{Horizontal_display_size} - 1$$

$$\text{LINEVAL} = \text{Vertical_display_size} - 1$$

The frame rate equation is used first without considering the clock periods added at the end beginning or at the end of each line to determine, approximately, the LCDDOTCK rate:

$$f_{\text{lcd_pclk}} = (\text{HOZVAL} + 5) \times (f_{\text{lcd_vsync}} \times (\text{LINEVAL} + 1))$$

With this value, the CLKVAL is fixed, as well as the corresponding LCDDOTCK rate.

Then select VHDLY, HPW and HBP according to the type of LCD used and [“Equation 1” on page 632](#).

Finally, the frame rate is adjusted to 70 Hz–75 Hz with the HFP value:

$$\text{HFP} = f_{\text{LCDDOTCK}} \times \left[\frac{1}{f_{\text{LCDVSYNC}} \times (\text{LINEVAL} + \text{VBP} + \text{VFP} + 1)} \right] - (\text{VHDLY} + \text{VPW} + \text{VBP} + \text{HOZVAL} + 5)$$

The line counting is controlled by the read-only field LINECNT of LCDCON1 register. The LINECNT field decreases by one unit at each falling edge of LCDHSYNC.

37.5.2.10 Display

This block is used to configure the polarity of the data and control signals. The polarity of all clock signals can be configured by LCDCON2[12:8] register setting.

This block also generates the lcd_pwr signal internally used to control the state of the LCD pins and to turn on and off by software the LCD module.

This signal is controlled by the PWRCON register and respects the number of frames configured in the GUARD_TIME field of PWRCON register (PWRCON[7:1]) between the write access to LCD_PWR field (PWRCON[0]) and the activation/deactivation of lcd_pwr signal.

The minimum value for the GUARD_TIME field is one frame. This gives the DMA Controller enough time to fill the FIFOs before the start of data transfer to the LCD.

37.5.2.11 PWM

This block generates the LCD contrast control signal (LCDCC) to make possible the control of the display's contrast by software. This is an 8-bit PWM (Pulse Width Modulation) signal that can be converted to an analog voltage with a simple passive filter.

The PWM module has a free-running counter whose value is compared against a compare register (CONTRAST_VAL register). If the value in the counter is less than that in the register, the output brings the value of the polarity (POL) bit in the PWM control register: CONTRAST_CTR. Otherwise, the opposite value is output. Thus, a periodic waveform with a pulse width proportional to the value in the compare register is generated.

Due to the comparison mechanism, the output pulse has a width between zero and 255 PWM counter cycles. Thus by adding a simple passive filter outside the chip, an analog voltage between 0 and $(255/256) \times VDD$ can be obtained (for the positive polarity case, or between $(1/256) \times VDD$ and VDD for the negative polarity case). Other voltage values can be obtained by adding active external circuitry.

For PWM mode, the frequency of the counter can be adjusted to four different values using field PS of CONTRAST_CTR.

37.5.3 LCD Interface

The LCD Controller interfaces with the LCD Module through the LCD Interface (Table 37-11 on page 640). The Controller supports the following interface configurations: 24-bit TFT single scan, 16-bit STN Dual Scan Mono (Color), 8-bit STN Dual (Single) Scan Mono (Color), 4-bit single scan Mono (Color).

A 4-bit single scan STN display uses 4 parallel data lines to shift data to successive single horizontal lines one at a time until the entire frame has been shifted and transferred. The 4 LSB pins of LCD Data Bus (LCDD [3:0]) can be directly connected to the LCD driver; the 20 MSB pins (LCDD [23:4]) are not used.

An 8-bit single scan STN display uses 8 parallel data lines to shift data to successive single horizontal lines one at a time until the entire frame has been shifted and transferred. The 8 LSB pins of LCD Data Bus (LCDD [7:0]) can be directly connected to the LCD driver; the 16 MSB pins (LCDD [23:8]) are not used.

An 8-bit Dual Scan STN display uses two sets of 4 parallel data lines to shift data to successive upper and lower panel horizontal lines one at a time until the entire frame has been shifted and transferred. The bus LCDD[3:0] is connected to the upper panel data lines and the bus LCDD[7:4] is connected to the lower panel data lines. The rest of the LCD Data Bus lines (LCDD[23:8]) are not used.

A 16-bit Dual Scan STN display uses two sets of 8 parallel data lines to shift data to successive upper and lower panel horizontal lines one at a time until the entire frame has been shifted and transferred. The bus LCDD[7:0] is connected to the upper panel data lines and the bus LCDD[15:8] is connected to the lower panel data lines. The rest of the LCD Data Bus lines (LCDD[23:16]) are not used.

STN Mono displays require one bit of image data per pixel. STN Color displays require three bits (Red, Green and Blue) of image data per pixel, resulting in a horizontal shift register of length three times the number of pixels per horizontal line. This RGB or Monochrome data is shifted to the LCD driver as consecutive bits via the parallel data lines.

A TFT single scan display uses up to 24 parallel data lines to shift data to successive horizontal lines one at a time until the entire frame has been shifted and transferred. The 24 data lines are divided in three bytes that define the color shade of each color component of each pixel. The LCDD bus is split as LCDD[23:16] for the blue component, LCDD[15:8] for the green component and LCDD[7:0] for the red component. If the LCD Module has lower color resolution (fewer bits per color component), only the most significant bits of each component are used.

All these interfaces are shown in Figure 37-6 to Figure 37-10. Figure 37-6 shows the 24-bit single scan TFT display timing; Figure 37-7 on page 637 shows the 4-bit single scan STN display timing for monochrome and color modes; Figure 37-8 on page 637 shows the 8-bit single scan STN display timing for monochrome and color modes; Figure 37-9 on page 638 shows the 8-bit Dual Scan STN display timing for monochrome and color modes; Figure 37-10 on page 639 shows the 16-bit Dual Scan STN display timing for monochrome and color modes.

Figure 37-6. TFT Timing (First Line Expanded View)

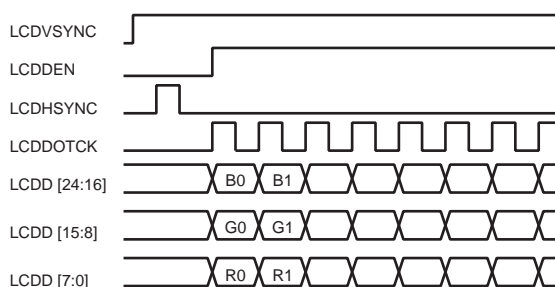

Figure 37-7. Single Scan Monochrome and Color 4-bit Panel Timing (First Line Expanded View)

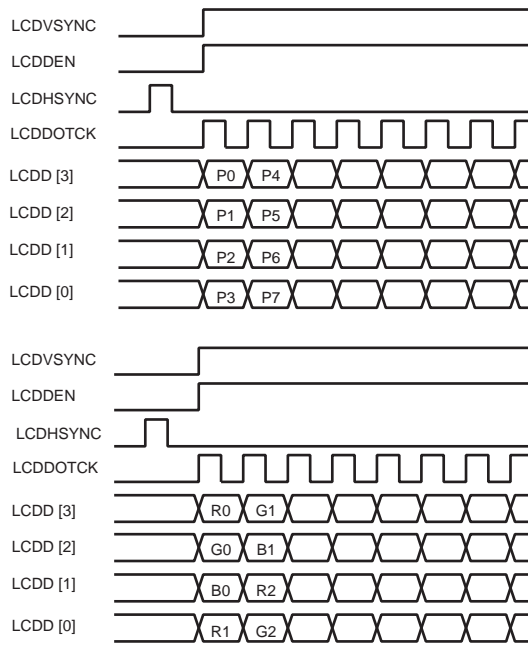

Figure 37-8. Single Scan Monochrome and Color 8-bit Panel Timing (First Line Expanded View)

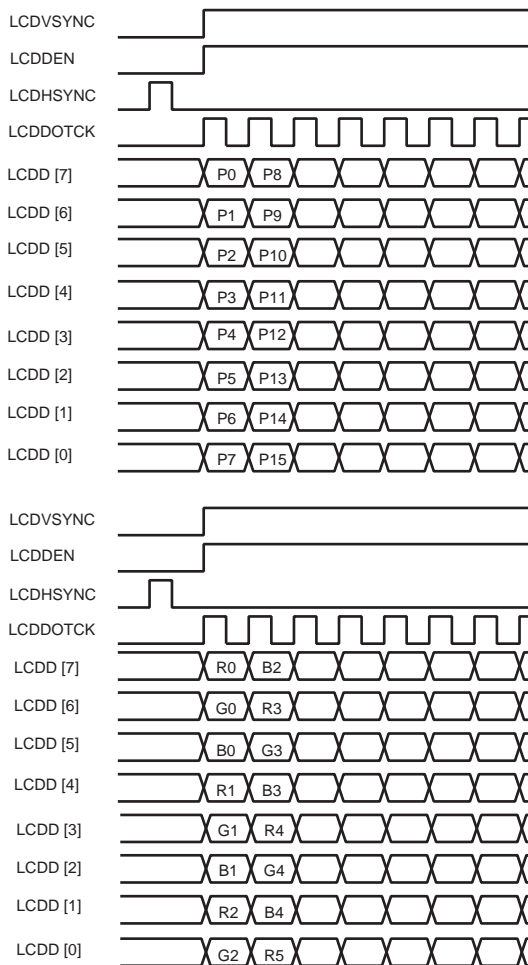

Figure 37-9. Dual Scan Monochrome and Color 8-bit Panel Timing (First Line Expanded View)

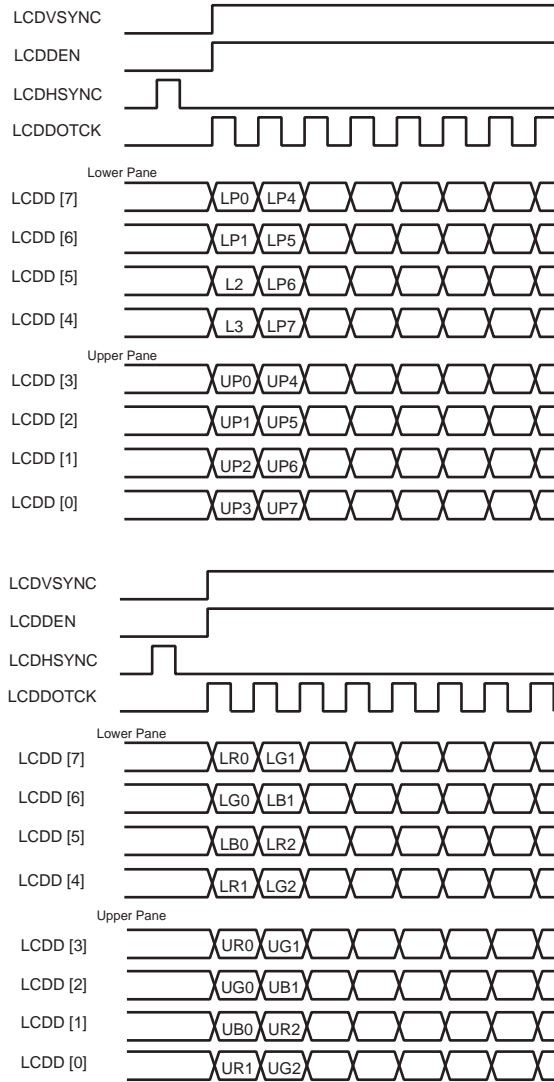

Figure 37-10. Dual Scan Monochrome and Color 16-bit Panel Timing (First Line Expanded View)

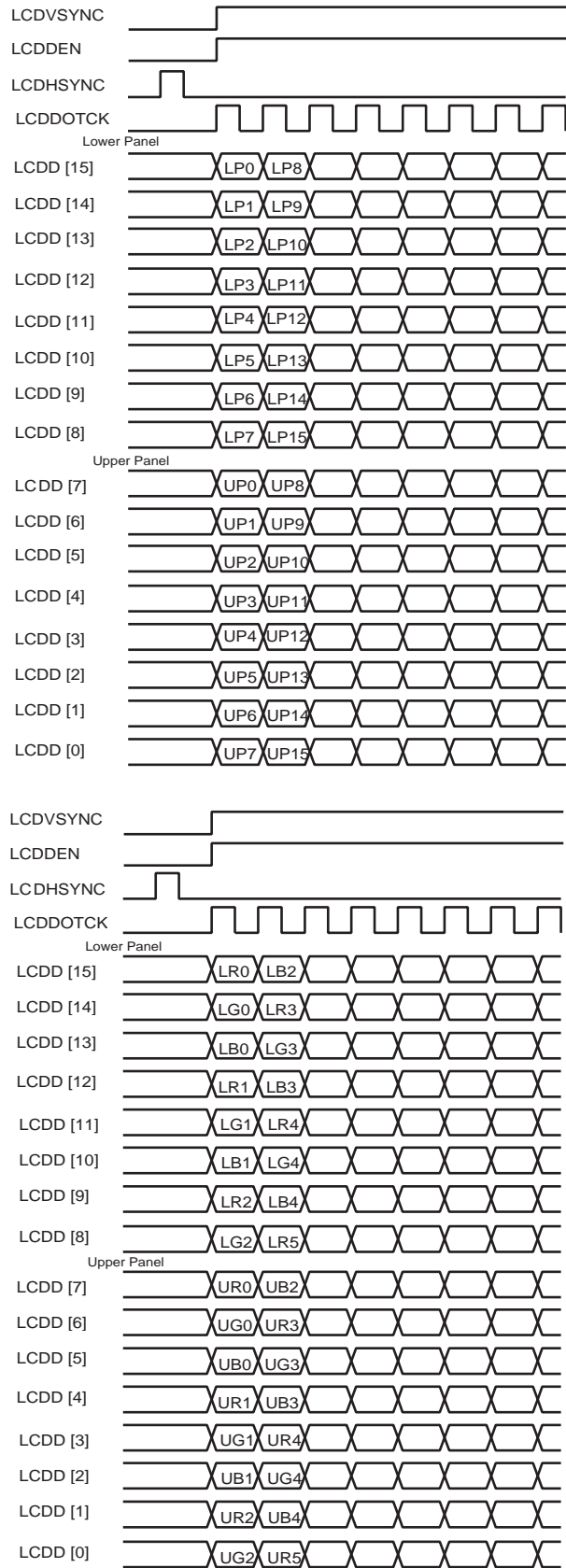

Table 37-11. LCD Signal Multiplexing

| LCD Data Bus | 4-bit STN Single Scan (mono, color) | 8-bit STN Single Scan (mono, color) | 8-bit STN Dual Scan (mono, color) | 16-bit STN Dual Scan (mono, color) | 24-bit TFT | 16-bit TFT |
|--------------|--|--|--------------------------------------|---------------------------------------|------------|---------------|
| LCDD[23] | | | | | LCD_BLUE7 | LCD_BLUE4 |
| LCDD[22] | | | | | LCD_BLUE6 | LCD_BLUE3 |
| LCDD[21] | | | | | LCD_BLUE5 | LCD_BLUE2 |
| LCDD[20] | | | | | LCD_BLUE4 | LCD_BLUE1 |
| LCDD[19] | | | | | LCD_BLUE3 | LCD_BLUE0 |
| LCDD[18] | | | | | LCD_BLUE2 | Intensity Bit |
| LCDD[17] | | | | | LCD_BLUE1 | |
| LCDD[16] | | | | | LCD_BLUE0 | |
| LCDD[15] | | | | LCDLP7 | LCD_GREEN7 | LCD_GREEN4 |
| LCDD[14] | | | | LCDLP6 | LCD_GREEN6 | LCD_GREEN3 |
| LCDD[13] | | | | LCDLP5 | LCD_GREEN5 | LCD_GREEN2 |
| LCDD[12] | | | | LCDLP4 | LCD_GREEN4 | LCD_GREEN1 |
| LCDD[11] | | | | LCDLP3 | LCD_GREEN3 | LCD_GREEN0 |
| LCDD[10] | | | | LCDLP2 | LCD_GREEN2 | Intensity Bit |
| LCDD[9] | | | | LCDLP1 | LCD_GREEN1 | |
| LCDD[8] | | | | LCDLP0 | LCD_GREEN0 | |
| LCDD[7] | | LCD7 | LCDLP3 | LCDUP7 | LCD_RED7 | LCD_RED4 |
| LCDD[6] | | LCD6 | LCDLP2 | LCDUP6 | LCD_RED6 | LCD_RED3 |
| LCDD[5] | | LCD5 | LCDLP1 | LCDUP5 | LCD_RED5 | LCD_RED2 |
| LCDD[4] | | LCD4 | LCDLP0 | LCDUP4 | LCD_RED4 | LCD_RED1 |
| LCDD[3] | LCD3 | LCD3 | LCDUP3 | LCDUP3 | LCD_RED3 | LCD_RED0 |
| LCDD[2] | LCD2 | LCD2 | LCDUP2 | LCDUP2 | LCD_RED2 | Intensity Bit |
| LCDD[1] | LCD1 | LCD1 | LCDUP1 | LCDUP1 | LCD_RED1 | |
| LCDD[0] | LCD0 | LCD0 | LCDUP0 | LCDUP0 | LCD_RED0 | |

37.6 Interrupts

The LCD Controller generates six different IRQs. All the IRQs are synchronized with the internal LCD Core Clock. The IRQs are:

- DMA Memory error IRQ. Generated when the DMA receives an error response from an AHB slave while it is doing a data transfer.
- FIFO underflow IRQ. Generated when the Serializer tries to read a word from the FIFO when the FIFO is empty.
- FIFO overwrite IRQ. Generated when the DMA Controller tries to write a word in the FIFO while the FIFO is full.
- DMA end of frame IRQ. Generated when the DMA controller updates the Frame Base Address pointers. This IRQ can be used to implement a double-buffer technique. For more information, see [“Double-buffer Technique” on page 642](#).
- End of Line IRQ. This IRQ is generated when the LINEBLANK period of each line is reached and the DMA Controller is in inactive state.
- End of Last Line IRQ. This IRQ is generated when the LINEBLANK period of the last line of the current frame is reached and the DMA Controller is in inactive state.

Each IRQ can be individually enabled, disabled or cleared, in the LCD_IER (Interrupt Enable Register), LCD_IDR (Interrupt Disable Register) and LCD_ICR (Interrupt Clear Register) registers. The LCD_IMR contains the mask value for each IRQ source and the LDC_ISR contains the status of each IRQ source. A more detailed description of these registers can be found in [“LCD Controller \(LDC\) User Interface” on page 644](#).

37.7 Configuration Sequence

The DMA Controller starts to transfer image data when the LDC Core is activated (Write to LCD_PWR field of PWRCON register). Thus, the user should configure the LDC Core and configure and enable the DMA Controller prior to activation of the LCD Controller. In addition, the image data to be shown should be available when the LDC Core is activated, regardless of the value programmed in the GUARD_TIME field of the PWRCON register.

To disable the LCD Controller, the user should disable the LDC Core and then disable the DMA Controller. The user should not enable LIP again until the LDC Core is in IDLE state. This is checked by reading the LCD_BUSY bit in the PWRCON register.

The initialization sequence that the user should follow to make the LDC work is:

- Create or copy the first image to show in the display buffer memory.
- If a palletized mode is used, create and store a palette in the internal LCD Palette memory(See [“Palette” on page 628](#)).
- ? Configure the LCD Controller Core without enabling it:
 - LCDCON1 register: Program the *CLKVAL* and *BYPASS* fields: these fields control the pixel clock divisor that is used to generate the pixel clock LCDDOTCK. The value to program depends on the LCD Core clock and on the type and size of the LCD Module used. There is a minimum value of the LCDDOTCK clock period that depends on the LCD Controller Configuration, this minimum value can be found in [Table 37-10 on page 631](#). The equations that are used to calculate the value of the pixel clock divisor can be found at the end of the section [“Timegen” on page 631](#)
 - LCDCON2 register: Program its fields following their descriptions in the LCD Controller User Interface section below and considering the type of LCD module used and the desired working mode. Consider that not all combinations are possible.
 - LCDDTIM1 and LCDDTIM2 registers: Program their fields according to the datasheet of the LCD module used and with the help of the Timegen section in page 10. Note that some fields are not applicable to STN modules and must be programmed with 0 values. Note also that there is a limitation on the minimum value of VHDLY, HPW, HBP that depends on the configuration of the LDC.

- LCDFRMCFG register: program the dimensions of the LCD module used.
- LCDFIFO register: To program it, use the formula in section “FIFO” on page 626.
- DP1_2 to DP6_7 registers: they are only used for STN displays. They contain the dithering patterns used to generate gray shades or colors in these modules. They are loaded with recommended patterns at reset, so it is not necessary to write anything on them. They can be used to improve the image quality in the display by tuning the patterns in each application.
- PWRCON Register: this register controls the powerup sequence of the LCD, so take care to use it properly. Do not enable the LCD (writing a 1 in LCD_PWR field) until the previous steps and the configuration of the DMA have been finished.
- CONTRAST_CTR and CONTRAST_VAL: use this registers to adjust the contrast of the display, when the *LCDC* line is used. ?
- Configure the DMA Controller. The user should configure the base address of the display buffer memory, the size of the AHB transaction and the size of the display image in memory. When the DMA is configured the user should enable the DMA. To do so the user should configure the following registers:
 - DMABADDR1 and DMABADDR2 registers: In single scan mode only DMABADDR1 register must be configured with the base address of the display buffer in memory. In dual scan mode DMABADDR1 should be configured with the base address of the Upper Panel display buffer and DMABADDR2 should be configured with the base address of the Lower Panel display buffer.
 - DMAFRMCFG register: Program the FRMSIZE field. Note that in dual scan mode the vertical size to use in the calculation is that of each panel. Respect to the BRSTLN field, a recommended value is a 4-word burst.
 - DMACON register: Once both the LCD Controller Core and the DMA Controller have been configured, enable the DMA Controller by writing a “1” to the DMAEN field of this register.
- Finally, enable the LCD Controller Core by writing a “1” in the LCD_PWR field of the PWRCON register and do any other action that may be required to turn the LCD module on.

37.8 Double-buffer Technique

The double-buffer technique is used to avoid flickering while the frame being displayed is updated. Instead of using a single buffer, there are two different buffers, the backbuffer (background buffer) and the primary buffer (the buffer being displayed).

The host updates the backbuffer while the LCD Controller is displaying the primary buffer. When the backbuffer has been updated the host updates the DMA Base Address registers.

When using a Dual Panel LCD Module, both base address pointers should be updated in the same frame. There are two possibilities:

- Check the DMAFRMPTx register to ensure that there is enough time to update the DMA Base Address registers before the end of frame.
- Update the Frame Base Address Registers when the End Of Frame IRQ is generated.

Once the host has updated the Frame Base Address Registers and the next DMA end of frame IRQ arrives, the backbuffer and the primary buffer are swapped and the host can work with the new backbuffer.

37.9 Register Configuration Guide

Program the PIO Controller to enable LCD signals.

Enable the LCD controller clock in the Power Management Controller.

PMC_SCER = 1 << 17; //LCDC HCLK = HCK1

37.9.1 STN Mode Example

STN color(R,G,B) 320*240, 8-bit single scan, 70 frames/sec, Master clock = 60 MHz

Data rate: $320 * 240 * 70 * 3 / 8 = 2.016$ MHz

HOZVAL = $((3 * 320) / 8) - 1$

LINEVAL = 240 - 1

CLKVAL = $(60 \text{ MHz} / (2 * 2.016 \text{ MHz})) - 1 = 14$

LCDCON1 = CLKVAL << 12

LCDCON2 = LITTLEENDIAN | SINGLESCAN | STNCOLOR | DISP8BIT | PS8BPP;

LCDTIM1 = 0;

LCDTIM2 = 10 | (10 << 21);

LCDFRMCFG = (HOZVAL << 21) | LINEVAL;

DMAFRMCFG = $(7 << 24) + (320 * 240 * 8) / 32$;

37.9.2 TFT Mode Example

This example is based on the NEC TFT color LCD module NL6448BC20-08.

TFT 640*480, 16-bit single scan, 60 frames/sec, pixel clock frequency = [21MHz..29MHz] with a typical value = 25.175 MHz.

The Master clock must be $(2 * (n + 1)) * \text{pixel clock frequency}$

HOZVAL = 640 - 1

LINEVAL = 480 - 1

If Master clock is 50 MHz

CLKVAL = $(50 \text{ MHz} / (2 * 25.175 \text{ MHz})) - 1 = 0$

VFP = (12 - 1), VBP = (31 - 1), VPW = (2 - 1), VHDLY = (2 - 1)

HFP = (16 - 2), HBP = (48 - 1), HPW = (64 - 1)

LCDCON1 = CLKVAL << 12

LCDCON2 = LITTLEENDIAN | CLKMOD | INVERT_CLK | INVERT_LINE | INVERT_FRM | PS16BPP | SINGLESCAN | TFT

LCDTIM1 = VFP | (VBP << 8) | (VPW << 16) | (VHDLY << 24)

LCDTIM2 = HBP | (HPW << 8) | (HFP << 21)

LCDFRMCFG = (HOZVAL << 21) | LINEVAL

DMAFRMCFG = $(7 << 24) + (640 * 480 * 16) / 32$;

37.10 LCD Controller (LDC) User Interface

Table 37-12. Register Mapping

| Offset | Register | Name | Access | Reset |
|--------|----------------------------------|---------------|------------|------------|
| 0x0 | DMA Base Address Register 1 | DMABADDR1 | Read/Write | 0x00000000 |
| 0x4 | DMA Base Address Register 2 | DMABADDR2 | Read/Write | 0x00000000 |
| 0x8 | DMA Frame Pointer Register 1 | DMAFRMPT1 | Read-only | 0x00000000 |
| 0xC | DMA Frame Pointer Register 2 | DMAFRMPT2 | Read-only | 0x00000000 |
| 0x10 | DMA Frame Address Register 1 | DMAFRMADD1 | Read-only | 0x00000000 |
| 0x14 | DMA Frame Address Register 2 | DMAFRMADD2 | Read-only | 0x00000000 |
| 0x18 | DMA Frame Configuration Register | DMAFRMCFG | Read/Write | 0x00000000 |
| 0x1C | DMA Control Register | DMACON | Read/Write | 0x00000000 |
| 0x800 | LCD Control Register 1 | LCDCON1 | Read/Write | 0x00002000 |
| 0x804 | LCD Control Register 2 | LCDCON2 | Read/Write | 0x00000000 |
| 0x808 | LCD Timing Register 1 | LCDTIM1 | Read/Write | 0x00000000 |
| 0x80C | LCD Timing Register 2 | LCDTIM2 | Read/Write | 0x00000000 |
| 0x810 | LCD Frame Configuration Register | LCDFRMCFG | Read/Write | 0x00000000 |
| 0x814 | LCD FIFO Register | LCDFIFO | Read/Write | 0x00000000 |
| 0x818 | Reserved | – | – | – |
| 0x81C | Dithering Pattern DP1_2 | DP1_2 | Read/Write | 0xA5 |
| 0x820 | Dithering Pattern DP4_7 | DP4_7 | Read/Write | 0x5AF0FA5 |
| 0x824 | Dithering Pattern DP3_5 | DP3_5 | Read/Write | 0xA5A5F |
| 0x828 | Dithering Pattern DP2_3 | DP2_3 | Read/Write | 0xA5F |
| 0x82C | Dithering Pattern DP5_7 | DP5_7 | Read/Write | 0xFAF5FA5 |
| 0x830 | Dithering Pattern DP3_4 | DP3_4 | Read/Write | 0xFAF5 |
| 0x834 | Dithering Pattern DP4_5 | DP4_5 | Read/Write | 0xFAF5F |
| 0x838 | Dithering Pattern DP6_7 | DP6_7 | Read/Write | 0xF5FFAFF |
| 0x83C | Power Control Register | PWRCON | Read/Write | 0x0000000e |
| 0x840 | Contrast Control Register | CONTRAST_CTR | Read/Write | 0x00000000 |
| 0x844 | Contrast Value Register | CONTRAST_VAL | Read/Write | 0x00000000 |
| 0x848 | LCD Interrupt Enable Register | LCD_IER | Write-only | – |
| 0x84C | LCD Interrupt Disable Register | LCD_IDR | Write-only | – |
| 0x850 | LCD Interrupt Mask Register | LCD_IMR | Read-only | 0x0 |
| 0x854 | LCD Interrupt Status Register | LCD_ISR | Read-only | 0x0 |
| 0x858 | LCD Interrupt Clear Register | LCD_ICR | Write-only | – |
| 0xC00 | Palette entry 0 | LUT ENTRY 0 | Read/Write | |
| 0xC04 | Palette entry 1 | LUT ENTRY 1 | Read/Write | |
| 0xC08 | Palette entry 2 | LUT ENTRY 2 | Read/Write | |
| 0xC0C | Palette entry 3 | LUT ENTRY 3 | Read/Write | |
| ... | | ... | | |
| 0xFFC | Palette entry 255 | LUT ENTRY 255 | Read/Write | |

37.10.1 DMA Base Address Register 1

Name: DMABADDR1

Address: 0x00600000

Access: Read/Write

| | | | | | | | |
|---------|----|----|----|----|----|----|----|
| 31 | 30 | 29 | 28 | 27 | 26 | 25 | 24 |
| BADDR-U | | | | | | | |
| 23 | 22 | 21 | 20 | 19 | 18 | 17 | 16 |
| BADDR-U | | | | | | | |
| 15 | 14 | 13 | 12 | 11 | 10 | 9 | 8 |
| BADDR-U | | | | | | | |
| 7 | 6 | 5 | 4 | 3 | 2 | 1 | 0 |
| BADDR-U | | | | | | 0 | 0 |

- **BADDR-U**

Base Address for the upper panel in dual scan mode. Base Address for the complete frame in single scan mode.

37.10.2 DMA Base Address Register 2

Name: DMABADDR2

Address: 0x00600004

Access: Read/Write

| | | | | | | | |
|---------|----|----|----|----|----|----|----|
| 31 | 30 | 29 | 28 | 27 | 26 | 25 | 24 |
| BADDR-L | | | | | | | |
| 23 | 22 | 21 | 20 | 19 | 18 | 17 | 16 |
| BADDR-L | | | | | | | |
| 15 | 14 | 13 | 12 | 11 | 10 | 9 | 8 |
| BADDR-L | | | | | | | |
| 7 | 6 | 5 | 4 | 3 | 2 | 1 | 0 |
| BADDR-L | | | | | | | |

- **BADDR-L**

Base Address for the lower panel in dual scan mode only.

37.10.3 DMA Frame Pointer Register 1

Name: DMAFRMPT1

Address: 0x00600008

Access: Read-only

| | | | | | | | |
|---------|---------|----|----|----|----|----|----|
| 31 | 30 | 29 | 28 | 27 | 26 | 25 | 24 |
| – | – | – | – | – | – | – | – |
| 23 | 22 | 21 | 20 | 19 | 18 | 17 | 16 |
| – | FRMPT-U | | | | | | |
| 15 | 14 | 13 | 12 | 11 | 10 | 9 | 8 |
| FRMPT-U | | | | | | | |
| 7 | 6 | 5 | 4 | 3 | 2 | 1 | 0 |
| FRMPT-U | | | | | | | |

- **FRMPT-U**

Current value of frame pointer for the upper panel in dual scan mode. Current value of frame pointer for the complete frame in single scan mode. Down count from FRMSIZE to 0.

Note: This register is read-only and contains the current value of the frame pointer (number of words to the end of the frame). It can be used as an estimation of the number of words transferred from memory for the current frame.

37.10.4 DMA Frame Pointer Register 2

Name: DMAFRMPT2

Address: 0x0060000C

Access: Read-only

| | | | | | | | |
|---------|---------|----|----|----|----|----|----|
| 31 | 30 | 29 | 28 | 27 | 26 | 25 | 24 |
| – | – | – | – | – | – | – | – |
| 23 | 22 | 21 | 20 | 19 | 18 | 17 | 16 |
| – | FRMPT-L | | | | | | |
| 15 | 14 | 13 | 12 | 11 | 10 | 9 | 8 |
| FRMPT-L | | | | | | | |
| 7 | 6 | 5 | 4 | 3 | 2 | 1 | 0 |
| FRMPT-L | | | | | | | |

- **FRMPT-L**

Current value of frame pointer for the Lower panel in dual scan mode only. Down count from FRMSIZE to 0.

Note: This register is read-only and contains the current value of the frame pointer (number of words to the end of the frame). It can be used as an estimation of the number of words transferred from memory for the current frame.

37.10.5 DMA Frame Address Register 1

Name: DMAFRMADD1

Address: 0x00600010

Access: Read-only

| | | | | | | | |
|----------|----|----|----|----|----|----|----|
| 31 | 30 | 29 | 28 | 27 | 26 | 25 | 24 |
| FRMADD-U | | | | | | | |
| 23 | 22 | 21 | 20 | 19 | 18 | 17 | 16 |
| FRMADD-U | | | | | | | |
| 15 | 14 | 13 | 12 | 11 | 10 | 9 | 8 |
| FRMADD-U | | | | | | | |
| 7 | 6 | 5 | 4 | 3 | 2 | 1 | 0 |
| FRMADD-U | | | | | | | |

- **FRMADD-U**

Current value of frame address for the upper panel in dual scan mode. Current value of frame address for the complete frame in single scan.

Note: This register is read-only and contains the current value of the last DMA transaction in the bus for the panel/frame.

37.10.6 DMA Frame Address Register 2

Name: DMAFRMADD2

Address: 0x00600014

Access: Read-only

| | | | | | | | |
|----------|----|----|----|----|----|----|----|
| 31 | 30 | 29 | 28 | 27 | 26 | 25 | 24 |
| FRMADD-L | | | | | | | |
| 23 | 22 | 21 | 20 | 19 | 18 | 17 | 16 |
| FRMADD-L | | | | | | | |
| 15 | 14 | 13 | 12 | 11 | 10 | 9 | 8 |
| FRMADD-L | | | | | | | |
| 7 | 6 | 5 | 4 | 3 | 2 | 1 | 0 |
| FRMADD-L | | | | | | | |

- **FRMADD-L**

Current value of frame address for the lower panel in single scan mode only.

Note: This register is read-only and contains the current value of the last DMA transaction in the bus for the panel.

37.10.7 DMA Frame Configuration Register

Name: DMAFRMCFG

Address: 0x00600018

Access: Read/Write

| | | | | | | | |
|---------|----|---------|----|----|----|----|----|
| 31 | 30 | 29 | 28 | 27 | 26 | 25 | 24 |
| - | | BRSTLN | | | | | |
| 23 | 22 | 21 | 20 | 19 | 18 | 17 | 16 |
| - | | FRMSIZE | | | | | |
| 15 | 14 | 13 | 12 | 11 | 10 | 9 | 8 |
| FRMSIZE | | | | | | | |
| 7 | 6 | 5 | 4 | 3 | 2 | 1 | 0 |
| FRMSIZE | | | | | | | |

- **FRMSIZE: Frame Size**

In single scan mode, this is the frame size in words. In dual scan mode, this is the size of each panel.

- **BRSTLN: Burst Length**

Program with the desired burst length - 1

37.10.8 DMA Control Register

Name: DMACON

Address: 0x0060001C

Access: Read/Write

| | | | | | | | |
|----|----|----|----|----|---------|--------|-------|
| 31 | 30 | 29 | 28 | 27 | 26 | 25 | 24 |
| – | – | – | – | – | – | – | – |
| 23 | 22 | 21 | 20 | 19 | 18 | 17 | 16 |
| – | – | – | – | – | – | – | – |
| 15 | 14 | 13 | 12 | 11 | 10 | 9 | 8 |
| – | – | – | – | – | – | – | – |
| 7 | 6 | 5 | 4 | 3 | 2 | 1 | 0 |
| – | – | – | – | – | DMABUSY | DMARST | DMAEN |

- **DMAEN: DMA Enable**

0: DMA is disabled.

1: DMA is enabled.

- **DMARST: DMA Reset (Write-only)**

0: No effect.

1: Reset DMA module. DMA Module should be reset only when disabled and in idle state.

- **DMABUSY: DMA Busy**

0: DMA module is idle.

1: DMA module is busy (doing a transaction on the AHB bus).

37.10.9 LCD Control Register 1

Name: LCDCON1

Address: 0x00600800

Access: Read/Write, except LINECNT: Read-only

| | | | | | | | |
|---------|----|----|----|--------|----|----|--------|
| 31 | 30 | 29 | 28 | 27 | 26 | 25 | 24 |
| LINECNT | | | | | | | |
| 23 | 22 | 21 | 20 | 19 | 18 | 17 | 16 |
| LINECNT | | | | CLKVAL | | | |
| 15 | 14 | 13 | 12 | 11 | 10 | 9 | 8 |
| CLKVAL | | | | – | – | – | – |
| 7 | 6 | 5 | 4 | 3 | 2 | 1 | 0 |
| – | – | – | – | – | – | – | BYPASS |

- **BYPASS: Bypass LCDDOTCK divider**

0: The divider is not bypassed. LCDDOTCK frequency defined by the CLKVAL field.

1: The LCDDOTCK divider is bypassed. LCDDOTCK frequency is equal to the LCDC Clock frequency.

- **CLKVAL: Clock divider**

9-bit divider for pixel clock (LCDDOTCK) frequency.

$$\text{Pixel_clock} = \text{system_clock} / (\text{CLKVAL} + 1) \times 2$$

- **LINECNT: Line Counter (Read-only)**

Current Value of 11-bit line counter. Down count from LINEVAL to 0.

37.10.10 LCD Control Register 2

Name: LCDCON2

Address: 0x00600804

Access: Read/Write

| | | | | | | | |
|-----------|----|----|---------|--------|---------|----------|-------|
| 31 | 30 | 29 | 28 | 27 | 26 | 25 | 24 |
| MEMOR | | – | – | – | – | – | – |
| 23 | 22 | 21 | 20 | 19 | 18 | 17 | 16 |
| – | – | – | – | – | – | – | – |
| 15 | 14 | 13 | 12 | 11 | 10 | 9 | 8 |
| CLKMOD | – | – | INVDVAL | INVCLK | INVLIN | INVFRAME | INVVD |
| 7 | 6 | 5 | 4 | 3 | 2 | 1 | 0 |
| PIXELSIZE | | | IFWIDTH | | SCANMOD | DISTYPE | |

- **DISTYPE: Display Type**

| Value | Description |
|-------|----------------|
| 0 0 | STN Monochrome |
| 0 1 | STN Color |
| 1 0 | TFT |
| 1 1 | Reserved |

- **SCANMOD: Scan Mode**

0: Single Scan

1: Dual Scan

- **IFWIDTH: Interface width (STN)**

| Value | Description |
|-------|---|
| 0 0 | 4-bit (Only valid in single scan STN mono or color) |
| 0 1 | 8-bit (Only valid in STN mono or Color) |
| 1 0 | 16-bit (Only valid in dual scan STN mono or color) |
| 1 1 | Reserved |

- **PIXELSIZE: Bits per pixel**

| Value | Description |
|-------|--|
| 0 0 0 | 1 bit per pixel |
| 0 0 1 | 2 bits per pixel |
| 0 1 0 | 4 bits per pixel |
| 0 1 1 | 8 bits per pixel |
| 1 0 0 | 16 bits per pixel |
| 1 0 1 | 24 bits per pixel, packed (Only valid in TFT mode) |
| 1 1 0 | Reserved |
| 1 1 1 | Reserved |

- **INVVD: LCDD polarity**

0: Normal

1: Inverted

- **INVFRAME: LCDVSYNC polarity**

0: Normal (active high)

1: Inverted (active low)

- **INVLIN: LCDHSYNC polarity**

0: Normal (active high)

1: Inverted (active low)

- **INVCLK: LCDDOTCK polarity**

0: Normal (LCDD fetched at LCDDOTCK falling edge)

1: Inverted (LCDD fetched at LCDDOTCK rising edge)

- **INVDVAL: LCDDEN polarity**

0: Normal (active high)

1: Inverted (active low)

- **CLKMOD: LCDDOTCK mode**

0: LCDDOTCK only active during active display period

1: LCDDOTCK always active

- **MEMOR: Memory Ordering Format**

00: Big Endian

10: Little Endian

37.10.11 LCD Timing Configuration Register 1

Name: LCDTIM1
Address: 0x00600808
Access: Read/Write

| | | | | | | | |
|-----|----|-----|----|-------|----|----|----|
| 31 | 30 | 29 | 28 | 27 | 26 | 25 | 24 |
| – | – | – | – | VHDLY | | | |
| 23 | 22 | 21 | 20 | 19 | 18 | 17 | 16 |
| – | – | VPW | | | | | |
| 15 | 14 | 13 | 12 | 11 | 10 | 9 | 8 |
| VBP | | | | | | | |
| 7 | 6 | 5 | 4 | 3 | 2 | 1 | 0 |
| VFP | | | | | | | |

- **VFP: Vertical Front Porch**

In TFT mode, these bits equal the number of idle lines at the end of the frame.

In STN mode, these bits should be set to 0.

- **VBP: Vertical Back Porch**

In TFT mode, these bits equal the number of idle lines at the beginning of the frame.

In STN mode, these bits should be set to 0.

- **VPW: Vertical Synchronization pulse width**

In TFT mode, these bits equal the vertical synchronization pulse width, given in number of lines. LCDVSYNC width is equal to (VPW+1) lines.

In STN mode, these bits should be set to 0.

- **VHDLY: Vertical to horizontal delay**

In TFT mode, this is the delay between LCDVSYNC rising or falling edge and LCDHSYNC rising edge. Delay is (VHDLY+1) LCDDOTCK cycles.

In STN mode, these bits should be set to 0.

37.10.12 LCD Timing Configuration Register 2

Name: LCDTIM2

Address: 0x0060080C

Access: Read/Write

| | | | | | | | |
|-----|----|----|----|-----|----|----|----|
| 31 | 30 | 29 | 28 | 27 | 26 | 25 | 24 |
| HFP | | | | | | | |
| 23 | 22 | 21 | 20 | 19 | 18 | 17 | 16 |
| HFP | | - | | - | | - | |
| 15 | 14 | 13 | 12 | 11 | 10 | 9 | 8 |
| - | | - | | HPW | | | |
| 7 | 6 | 5 | 4 | 3 | 2 | 1 | 0 |
| HBP | | | | | | | |

- **HBP: Horizontal Back Porch**

Number of idle LCDDOTCK cycles at the beginning of the line. Idle period is (HBP+1) LCDDOTCK cycles.

- **HPW: Horizontal synchronization pulse width**

Width of the LCDHSYNC pulse, given in LCDDOTCK cycles. Width is (HPW+1) LCDDOTCK cycles.

- **HFP: Horizontal Front Porch**

Number of idle LCDDOTCK cycles at the end of the line. Idle period is (HFP+2) LCDDOTCK cycles.

37.10.13 LCD Frame Configuration Register

Name: LCDFRMCFG

Address: 0x00600810

Access: Read/Write

| | | | | | | | |
|---------|----|----|----|----|---------|----|----|
| 31 | 30 | 29 | 28 | 27 | 26 | 25 | 24 |
| HOZVAL | | | | | | | |
| 23 | 22 | 21 | 20 | 19 | 18 | 17 | 16 |
| HOZVAL | | – | – | – | – | – | – |
| 15 | 14 | 13 | 12 | 11 | 10 | 9 | 8 |
| – | – | – | – | – | LINEVAL | | |
| 7 | 6 | 5 | 4 | 3 | 2 | 1 | 0 |
| LINEVAL | | | | | | | |

- **LINEVAL: Vertical size of LCD module**

LINEVAL = (Vertical display size) - 1

In dual scan mode, vertical display size refers to the size of each panel.

- **HOZVAL: Horizontal size of LCD module**

In STN Mode:

- HOZVAL = (Horizontal display size / Number of valid LCDD data line) - 1
- In STN monochrome mode, Horizontal display size = Number of horizontal pixels
- In STN color mode, Horizontal display size = 3*Number of horizontal pixels
- In 4-bit single scan or 8-bit dual scan STN display mode, number of valid LCDD data lines = 4
- In 8-bit single scan or 16-bit dual scan STN display mode, number of valid LCDD data lines = 8
- If the value calculated for HOZVAL with the above formula is not an integer, it must be rounded up to the next integer value.

In TFT mode:

- HOZVAL = Horizontal display size

37.10.14 LCD FIFO Register

Name: LCDFIFO

Address: 0x00600814

Access: Read/Write

| | | | | | | | |
|--------|----|----|----|----|----|----|----|
| 31 | 30 | 29 | 28 | 27 | 26 | 25 | 24 |
| – | – | – | – | – | – | – | – |
| 23 | 22 | 21 | 20 | 19 | 18 | 17 | 16 |
| – | – | – | – | – | – | – | – |
| 15 | 14 | 13 | 12 | 11 | 10 | 9 | 8 |
| FIFOTH | | | | | | | |
| 7 | 6 | 5 | 4 | 3 | 2 | 1 | 0 |
| FIFOTH | | | | | | | |

- **FIFOTH: FIFO Threshold**

Must be programmed with:

$$\text{FIFOTH} = 512 - (2 \times \text{DMA_BURST_LENGTH} + 3)$$

where:

- 512 is the effective size of the FIFO. It is the total FIFO memory size in single scan mode and half that size in dual scan mode.
- DMA_burst_length is the burst length of the transfers made by the DMA. Refer to [“BRSTLN: Burst Length” on page 651](#).

37.10.15 Dithering Pattern DP1_2 Register

Name: DP1_2

Address: 0x0060081C

Access: Read/Write

| | | | | | | | |
|-------|----|----|----|----|----|----|----|
| 31 | 30 | 29 | 28 | 27 | 26 | 25 | 24 |
| – | – | – | – | – | – | – | – |
| 23 | 22 | 21 | 20 | 19 | 18 | 17 | 16 |
| – | – | – | – | – | – | – | – |
| 15 | 14 | 13 | 12 | 11 | 10 | 9 | 8 |
| – | – | – | – | – | – | – | – |
| 7 | 6 | 5 | 4 | 3 | 2 | 1 | 0 |
| DP1_2 | | | | | | | |

- **DP1_2:** Pattern value for ½ duty cycle

37.10.16 Dithering Pattern DP4_7 Register

Name: DP4_7

Address: 0x00600820

Access: Read/Write

| | | | | | | | |
|-------|----|----|----|-------|----|----|----|
| 31 | 30 | 29 | 28 | 27 | 26 | 25 | 24 |
| – | – | – | – | DP4_7 | | | |
| 23 | 22 | 21 | 20 | 19 | 18 | 17 | 16 |
| DP4_7 | | | | | | | |
| 15 | 14 | 13 | 12 | 11 | 10 | 9 | 8 |
| DP4_7 | | | | | | | |
| 7 | 6 | 5 | 4 | 3 | 2 | 1 | 0 |
| DP4_7 | | | | | | | |

- **DP4_7:** Pattern value for 4/7 duty cycle

37.10.17 Dithering Pattern DP3_5 Register

Name: DP3_5

Address: 0x00600824

Access: Read/Write

| | | | | | | | |
|-------|----|----|----|-------|----|----|----|
| 31 | 30 | 29 | 28 | 27 | 26 | 25 | 24 |
| – | – | – | – | – | – | – | – |
| 23 | 22 | 21 | 20 | 19 | 18 | 17 | 16 |
| – | – | – | – | DP3_5 | | | |
| 15 | 14 | 13 | 12 | 11 | 10 | 9 | 8 |
| DP3_5 | | | | | | | |
| 7 | 6 | 5 | 4 | 3 | 2 | 1 | 0 |
| DP3_5 | | | | | | | |

- **DP3_5:** Pattern value for 3/5 duty cycle

37.10.18 Dithering Pattern DP2_3 Register

Name: DP2_3

Address: 0x00600828

Access: Read/Write

| | | | | | | | |
|-------|----|----|----|-------|----|----|----|
| 31 | 30 | 29 | 28 | 27 | 26 | 25 | 24 |
| – | – | – | – | – | – | – | – |
| 23 | 22 | 21 | 20 | 19 | 18 | 17 | 16 |
| – | – | – | – | – | – | – | – |
| 15 | 14 | 13 | 12 | 11 | 10 | 9 | 8 |
| – | – | – | – | DP2_3 | | | |
| 7 | 6 | 5 | 4 | 3 | 2 | 1 | 0 |
| DP2_3 | | | | | | | |

- **DP2_3:** Pattern value for 2/3 duty cycle

37.10.19 Dithering Pattern DP5_7 Register

Name: DP5_7

Address: 0x0060082C

Access: Read/Write

| | | | | | | | |
|-------|----|----|----|-------|----|----|----|
| 31 | 30 | 29 | 28 | 27 | 26 | 25 | 24 |
| – | – | – | – | DP5_7 | | | |
| 23 | 22 | 21 | 20 | 19 | 18 | 17 | 16 |
| DP5_7 | | | | | | | |
| 15 | 14 | 13 | 12 | 11 | 10 | 9 | 8 |
| DP5_7 | | | | | | | |
| 7 | 6 | 5 | 4 | 3 | 2 | 1 | 0 |
| DP5_7 | | | | | | | |

- **DP5_7:** Pattern value for 5/7 duty cycle

37.10.20 Dithering Pattern DP3_4 Register

Name: DP3_4

Address: 0x00600830

Access: Read/Write

| | | | | | | | |
|-------|----|----|----|----|----|----|----|
| 31 | 30 | 29 | 28 | 27 | 26 | 25 | 24 |
| – | – | – | – | – | – | – | – |
| 23 | 22 | 21 | 20 | 19 | 18 | 17 | 16 |
| – | – | – | – | – | – | – | – |
| 15 | 14 | 13 | 12 | 11 | 10 | 9 | 8 |
| DP3_4 | | | | | | | |
| 7 | 6 | 5 | 4 | 3 | 2 | 1 | 0 |
| DP3_4 | | | | | | | |

- **DP3_4:** Pattern value for 3/4 duty cycle

37.10.21 Dithering Pattern DP4_5 Register

Name: DP4_5

Address: 0x00600834

Access: Read/Write

| | | | | | | | |
|-------|----|----|----|-------|----|----|----|
| 31 | 30 | 29 | 28 | 27 | 26 | 25 | 24 |
| – | – | – | – | – | – | – | – |
| 23 | 22 | 21 | 20 | 19 | 18 | 17 | 16 |
| – | – | – | – | DP4_5 | | | |
| 15 | 14 | 13 | 12 | 11 | 10 | 9 | 8 |
| DP4_5 | | | | | | | |
| 7 | 6 | 5 | 4 | 3 | 2 | 1 | 0 |
| DP4_5 | | | | | | | |

- **DP4_5:** Pattern value for 4/5 duty cycle

37.10.22 Dithering Pattern DP6_7 Register

Name: DP6_7

Address: 0x00600838

Access: Read/Write

| | | | | | | | |
|-------|----|----|----|-------|----|----|----|
| 31 | 30 | 29 | 28 | 27 | 26 | 25 | 24 |
| – | – | – | – | DP6_7 | | | |
| 23 | 22 | 21 | 20 | 19 | 18 | 17 | 16 |
| DP6_7 | | | | | | | |
| 15 | 14 | 13 | 12 | 11 | 10 | 9 | 8 |
| DP6_7 | | | | | | | |
| 7 | 6 | 5 | 4 | 3 | 2 | 1 | 0 |
| DP6_7 | | | | | | | |

- DP6_7: Pattern value for 6/7 duty cycle

37.10.23 Power Control Register

Name: PWRCON

Address: 0x0060083C

Access: Read/Write

| | | | | | | | |
|------------|----|----|----|----|----|----|---------|
| 31 | 30 | 29 | 28 | 27 | 26 | 25 | 24 |
| LCD_BUSY | – | – | – | – | – | – | – |
| 23 | 22 | 21 | 20 | 19 | 18 | 17 | 16 |
| – | – | – | – | – | – | – | – |
| 15 | 14 | 13 | 12 | 11 | 10 | 9 | 8 |
| – | – | – | – | – | – | – | – |
| 7 | 6 | 5 | 4 | 3 | 2 | 1 | 0 |
| GUARD_TIME | | | | | | | LCD_PWR |

- **LCD_PWR: LCD module power control**

0: lcd_pwr signal is low, other lcd_* signals are low.

0->1: lcd_* signals activated, lcd_pwr is set high with the delay of GUARD_TIME frame periods.

1: lcd_pwr signal is high, other lcd_* signals are active.

1->0: lcd_pwr signal is low, other lcd_* signals are active, but are set low after GUARD_TIME frame periods.

- **GUARD_TIME**

Delay in frame periods between applying control signals to the LCD module and setting LCD_PWR high, and between setting LCD_PWR low and removing control signals from LCD module

- **LCD_BUSY**

Read-only field. If 1, it indicates that the LCD is busy (active and displaying data, in power on sequence or in power off sequence).

37.10.24 Contrast Control Register

Name: CONTRAST_CTR

Address: 0x00600840

Access: Read/Write

| | | | | | | | |
|----|----|----|----|-----|-----|----|----|
| 31 | 30 | 29 | 28 | 27 | 26 | 25 | 24 |
| – | – | – | – | – | – | – | – |
| 23 | 22 | 21 | 20 | 19 | 18 | 17 | 16 |
| – | – | – | – | – | – | – | – |
| 15 | 14 | 13 | 12 | 11 | 10 | 9 | 8 |
| – | – | – | – | – | – | – | – |
| 7 | 6 | 5 | 4 | 3 | 2 | 1 | 0 |
| – | – | – | – | ENA | POL | PS | |

- **PS**

This 2-bit value selects the configuration of a counter prescaler. The meaning of each combination is as follows:

| Value | Description |
|-------|--|
| 0 0 | The counter advances at a rate of $f_{\text{COUNTER}} = f_{\text{LDC_CLOCK}}$. |
| 0 1 | The counter advances at a rate of $f_{\text{COUNTER}} = f_{\text{LDC_CLOCK}}/2$. |
| 1 0 | The counter advances at a rate of $f_{\text{COUNTER}} = f_{\text{LDC_CLOCK}}/4$. |
| 1 1 | The counter advances at a rate of $f_{\text{COUNTER}} = f_{\text{LDC_CLOCK}}/8$. |

- **POL**

This bit defines the polarity of the output. If 1, the output pulses are high level (the output will be high whenever the value in the counter is less than the value in the compare register CONTRAST_VAL). If 0, the output pulses are low level.

- **ENA**

When 1, this bit enables the operation of the PWM generator. When 0, the PWM counter is stopped.

37.10.25 Contrast Value Register

Name: CONTRAST_VAL

Address: 0x00600844

Access: Read/Write

| | | | | | | | |
|------|----|----|----|----|----|----|----|
| 31 | 30 | 29 | 28 | 27 | 26 | 25 | 24 |
| – | – | – | – | – | – | – | – |
| 23 | 22 | 21 | 20 | 19 | 18 | 17 | 16 |
| – | – | – | – | – | – | – | – |
| 15 | 14 | 13 | 12 | 11 | 10 | 9 | 8 |
| – | – | – | – | – | – | – | – |
| 7 | 6 | 5 | 4 | 3 | 2 | 1 | 0 |
| CVAL | | | | | | | |

- **CVAL**

PWM compare value. Used to adjust the analog value obtained after an external filter to control the contrast of the display.

37.10.26 LCD Interrupt Enable Register

Name: LCD_IER

Address: 0x00600848

Access: Write-only

| | | | | | | | |
|----|-------|-------|--------|----|-------|---------|------|
| 31 | 30 | 29 | 28 | 27 | 26 | 25 | 24 |
| – | – | – | – | – | – | – | – |
| 23 | 22 | 21 | 20 | 19 | 18 | 17 | 16 |
| – | – | – | – | – | – | – | – |
| 15 | 14 | 13 | 12 | 11 | 10 | 9 | 8 |
| – | – | – | – | – | – | – | – |
| 7 | 6 | 5 | 4 | 3 | 2 | 1 | 0 |
| – | MERIE | OWRIE | UFLWIE | – | EOFIE | LSTLNIE | LNIE |

- **LNIE: Line interrupt enable**

0: No effect

1: Enable each line interrupt

- **LSTLNIE: Last line interrupt enable**

0: No effect

1: Enable last line interrupt

- **EOFIE: DMA End of frame interrupt enable**

0: No effect

1: Enable End Of Frame interrupt

- **UFLWIE: FIFO underflow interrupt enable**

0: No effect

1: Enable FIFO underflow interrupt

- **OWRIE: FIFO overwrite interrupt enable**

0: No effect

1: Enable FIFO overwrite interrupt

- **MERIE: DMA memory error interrupt enable**

0: No effect

1: Enable DMA memory error interrupt

37.10.27 LCD Interrupt Disable Register

Name: LCD_IDR

Address: 0x0060084C

Access: Write-only

| | | | | | | | |
|----|-------|-------|--------|----|-------|---------|------|
| 31 | 30 | 29 | 28 | 27 | 26 | 25 | 24 |
| – | – | – | – | – | – | – | – |
| 23 | 22 | 21 | 20 | 19 | 18 | 17 | 16 |
| – | – | – | – | – | – | – | – |
| 15 | 14 | 13 | 12 | 11 | 10 | 9 | 8 |
| – | – | – | – | – | – | – | – |
| 7 | 6 | 5 | 4 | 3 | 2 | 1 | 0 |
| – | MERID | OWRID | UFLWID | – | EOFID | LSTLNID | LNID |

- **LNID: Line interrupt disable**

0: No effect

1: Disable each line interrupt

- **LSTLNID: Last line interrupt disable**

0: No effect

1: Disable last line interrupt

- **EOFID: DMA End of frame interrupt disable**

0: No effect

1: Disable End Of Frame interrupt

- **UFLWID: FIFO underflow interrupt disable**

0: No effect

1: Disable FIFO underflow interrupt

- **OWRID: FIFO overwrite interrupt disable**

0: No effect

1: Disable FIFO overwrite interrupt

- **MERID: DMA Memory error interrupt disable**

0: No effect

1: Disable DMA Memory error interrupt

37.10.28 LCD Interrupt Mask Register

Name: LCD_IMR
Address: 0x00600850
Access: Read-only

| | | | | | | | |
|----|-------|-------|--------|----|-------|---------|------|
| 31 | 30 | 29 | 28 | 27 | 26 | 25 | 24 |
| – | – | – | – | – | – | – | – |
| 23 | 22 | 21 | 20 | 19 | 18 | 17 | 16 |
| – | – | – | – | – | – | – | – |
| 15 | 14 | 13 | 12 | 11 | 10 | 9 | 8 |
| – | – | – | – | – | – | – | – |
| 7 | 6 | 5 | 4 | 3 | 2 | 1 | 0 |
| – | MERIM | OWRIM | UFLWIM | – | EOFIM | LSTLNIM | LNIM |

- **LNIM: Line interrupt mask**

0: Line Interrupt disabled

1: Line interrupt enabled

- **LSTLNIM: Last line interrupt mask**

0: Last Line Interrupt disabled

1: Last Line Interrupt enabled

- **EOFIM: DMA End of frame interrupt mask**

0: End Of Frame interrupt disabled

1: End Of Frame interrupt enabled

- **UFLWIM: FIFO underflow interrupt mask**

0: FIFO underflow interrupt disabled

1: FIFO underflow interrupt enabled

- **OWRIM: FIFO overwrite interrupt mask**

0: FIFO overwrite interrupt disabled

1: FIFO overwrite interrupt enabled

- **MERIM: DMA Memory error interrupt mask**

0: DMA Memory error interrupt disabled

1: DMA Memory error interrupt enabled

37.10.29 LCD Interrupt Status Register

Name: LCD_ISR

Address: 0x00600854

Access: Read-only

| | | | | | | | |
|----|-------|-------|--------|----|-------|---------|------|
| 31 | 30 | 29 | 28 | 27 | 26 | 25 | 24 |
| – | – | – | – | – | – | – | – |
| 23 | 22 | 21 | 20 | 19 | 18 | 17 | 16 |
| – | – | – | – | – | – | – | – |
| 15 | 14 | 13 | 12 | 11 | 10 | 9 | 8 |
| – | – | – | – | – | – | – | – |
| 7 | 6 | 5 | 4 | 3 | 2 | 1 | 0 |
| – | MERIS | OWRIS | UFLWIS | – | EOFIS | LSTLNIS | LNIS |

- **LNIS: Line interrupt status**

0: Line Interrupt not active

1: Line Interrupt active

- **LSTLNIS: Last line interrupt status**

0: Last Line Interrupt not active

1: Last Line Interrupt active

- **EOFIS: DMA End of frame interrupt status**

0: End Of Frame interrupt not active

1: End Of Frame interrupt active

- **UFLWIS: FIFO underflow interrupt status**

0: FIFO underflow interrupt not active

1: FIFO underflow interrupt active

- **OWRIS: FIFO overwrite interrupt status**

0: FIFO overwrite interrupt not active

1: FIFO overwrite interrupt active

- **MERIS: DMA Memory error interrupt status**

0: DMA Memory error interrupt not active

1: DMA Memory error interrupt active

37.10.30 LCD Interrupt Clear Register

Name: LCD_ICR

Address: 0x00600858

Access: Write-only

| | | | | | | | |
|----|-------|-------|--------|----|-------|---------|------|
| 31 | 30 | 29 | 28 | 27 | 26 | 25 | 24 |
| – | – | – | – | – | – | – | – |
| 23 | 22 | 21 | 20 | 19 | 18 | 17 | 16 |
| – | – | – | – | – | – | – | – |
| 15 | 14 | 13 | 12 | 11 | 10 | 9 | 8 |
| – | – | – | – | – | – | – | – |
| 7 | 6 | 5 | 4 | 3 | 2 | 1 | 0 |
| – | MERIC | OWRIC | UFLWIC | – | EOFIC | LSTLNIC | LNIC |

- **LNIC: Line interrupt clear**

0: No effect

1: Clear each line interrupt

- **LSTLNIC: Last line interrupt clear**

0: No effect

1: Clear Last line Interrupt

- **EOFIC: DMA End of frame interrupt clear**

0: No effect

1: Clear End Of Frame interrupt

- **UFLWIC: FIFO underflow interrupt clear**

0: No effect

1: Clear FIFO underflow interrupt

- **OWRIC: FIFO overwrite interrupt clear**

0: No effect

1: Clear FIFO overwrite interrupt

- **MERIC: DMA Memory error interrupt clear**

0: No effect

1: Clear DMA Memory error interrupt

38. Electrical Characteristics

38.1 Absolute Maximum Ratings

Table 38-1. Absolute Maximum Ratings*

| | |
|---|-----------------|
| Storage Temperature..... | -60°C to +150°C |
| Voltage on Input Pins with Respect to Ground | -0.3V to +4.0V |
| Maximum Operating Voltage (VDDCORE and VDDDBU)..... | 1.5V |
| Maximum Operating Voltage (VDDOSC, VDDPLL, VDDIOM and VDDIOP)..... | 4.0V |
| Total DC Output Current on all I/O lines..... | 350mA |

*NOTICE: Stresses beyond those listed under “Absolute Maximum Ratings” may cause permanent damage to the device. This is a stress rating only and functional operation of the device at these or other conditions beyond those indicated in the operational sections of this specification is not implied. Exposure to absolute maximum rating conditions for extended periods may affect device reliability.

38.2 DC Characteristics

The following characteristics are applicable to the operating temperature range: $T_A = -40^{\circ}\text{C}$ to 85°C , unless otherwise specified.

Table 38-2. DC Characteristics

| Symbol | Parameter | Conditions | Min | Typ | Max | Unit |
|--------------|---------------------------|--|-----------------------|-----|--------------------------|---------------|
| V_{DDCORE} | DC Supply Core | – | 1.08 | 1.2 | 1.32 | V |
| V_{DDBU} | DC Supply Backup | – | 1.08 | 1.2 | 1.32 | V |
| V_{DDOSC} | DC Supply Oscillator | – | 3.0 | 3.3 | 3.6 | V |
| V_{DDPLL} | DC Supply PLL | – | 3.0 | 3.3 | 3.6 | V |
| V_{DDIOM} | DC Supply Memory I/Os | – | 1.65 | 1.8 | 1.95 | V |
| | | – | 3.0 | 3.3 | 3.6 | |
| V_{DDIOP} | DC Supply Peripheral I/Os | – | 2.7 | 3.3 | 3.6 | V |
| V_{IL} | Input Low-level Voltage | V_{DDIO} 3.0–3.6 V | -0.3 | – | 0.8 | V |
| | | V_{DDIO} 1.65–1.95 V | -0.3 | – | $0.3 \times V_{DDIO}$ | |
| V_{IH} | Input High-level Voltage | V_{DDIO} 3.0–3.6 V | 2.0 | – | $V_{DDIO} + 0.3\text{V}$ | V |
| | | V_{DDIO} 1.65–1.95 V | $0.7 \times V_{DDIO}$ | – | $V_{DDIO} + 0.3\text{V}$ | |
| V_{OL} | Output Low-level Voltage | I_O Max, V_{DDIO} 3.0–3.6 V | – | – | 0.4 | V |
| | | CMOS ($I_O < 0.3$ mA), V_{DDIO} 1.65–1.95 V | – | – | 0.1 | |
| | | TTL (I_O Max), V_{DDIO} 1.65–1.95 V | – | – | 0.4 | |
| V_{OH} | Output High-level Voltage | I_O Max, V_{DDIO} 3.0–3.6 V | $V_{DDIO} - 0.4$ | – | – | V |
| | | CMOS ($I_O < 0.3$ mA), V_{DDIO} 1.65–1.95 V | $V_{DDIO} - 0.1$ | – | – | |
| | | TTL (I_O Max), V_{DDIO} 1.65–1.95 V | $V_{DDIO} - 0.4$ | – | – | |
| I_{LEAK} | Input Leakage Current | Pullup resistors disabled | – | – | ± 1 | μA |
| C_{IN} | Input Capacitance | 217-ball LFBGA Package | – | – | 5.0 | pF |
| R_{PULLUP} | Pull-up Resistance | PA0–PA31, PB0–PB31, PC0–PC31 | 70 | 100 | 175 | k Ω |

Table 38-2. DC Characteristics (Continued)

| Symbol | Parameter | Conditions | Min | Typ | Max | Unit | |
|----------|----------------|--|--------------------|-----|------|------|---------|
| I_O | Output Current | PA0–PA31, PB0–PB31, PC0–PC31, SHDN | – | – | 8 | mA | |
| I_{SC} | Static Current | On $V_{DDCORE} = 1.2V$, MCK = 0 Hz, excluding POR, All inputs driven TMS, TDI, TCK, NRST = 1 | $T_A = 25^\circ C$ | – | 245 | – | μA |
| | | | $T_A = 85^\circ C$ | – | – | 3000 | |
| | | On $V_{DDBU} = 1.2V$, Logic cells consumption, excluding POR, All inputs driven WKUP = 0 | $T_A = 25^\circ C$ | – | 1.13 | – | |
| | | | $T_A = 85^\circ C$ | – | – | 9.8 | |

38.3 Power Consumption

- Power consumption of power supply in four different modes: Full Speed, Idle Mode, Quasi Static and Backup.
- Power consumption by peripheral: calculated as the difference in current measurement after having enabled then disabled the corresponding clock.

38.3.1 Power Consumption versus Modes

The values in [Table 38-3](#) and [Table 38-4](#) are measured values of power consumption with operating conditions as follows:

- $V_{DDIOM} = V_{DDIOP} = 3.3V$
- $V_{DDPLL} = V_{DDOSC} = 3.3V$
- There is no consumption on the I/Os of the device.

Figure 38-1. Measures Schematics

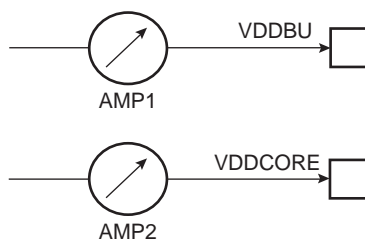

These figures represent the power consumption measured on the power supplies.

Table 38-3. Power Consumption for Different Modes

| Mode | Conditions | | Consumption | Unit |
|---------------------|---|---|-------------|---------|
| Full speed | ARM Core clock is 188 MHz MCK is 94 MHz Dhrystone running in lcache onto AMP2 | $V_{DDCORE} = 1.08V$ $T_A = 85^{\circ}C$ | 52.7 | mA |
| | | $V_{DDCORE} = 1.2V$ $T_A = 85^{\circ}C$ | 58 | |
| | | $V_{DDCORE} = 1.2V$ $T_A = 25^{\circ}C$ | 54 | |
| Idle ⁽¹⁾ | MCK is 96 MHz ARM core in idle state, waiting on interrupt Processor clock disabled onto AMP2 | $V_{DDCORE} = 1.08V$ $T_A = 85^{\circ}C$ | 12.0 | mA |
| | | $V_{DDCORE} = 1.2V$ $T_A = 85^{\circ}C$ | 14.6 | |
| | | $V_{DDCORE} = 1.2V$ $T_A = 25^{\circ}C$ | 10.9 | |
| Quasi Static | ARM Core clock is 500 Hz MCK is 500 Hz onto AMP2 | $V_{DDCORE} = 1.08V$ $T_A = 85^{\circ}C$ | 2300 | μA |
| | | $V_{DDCORE} = 1.2V$ $T_A = 85^{\circ}C$ | 2450 | |
| | | $V_{DDCORE} = 1.2V$ $T_A = 25^{\circ}C$ | 260 | |
| Backup | In Shutdown Mode onto AMP1 | $V_{DDBU} = 1.08V$ $T_A = 85^{\circ}C$ | 6 | μA |
| | | $V_{DDBU} = 1.2V$ $T_A = 85^{\circ}C$ | 6.7 | |
| | | $V_{DDBU} = 1.2V$ $T_A = 25^{\circ}C$ | 2.5 | |

Note: 1. No SRAM access in Idle Mode.

Table 38-4. Power Consumption by Peripheral ($T_A = 25^{\circ}C$, $V_{DDCORE} = 1.2V$)

| Peripheral | Consumption | Unit |
|------------------------|-------------|-------------|
| LCDC | 40.2 | $\mu A/MHz$ |
| MCI | 12.9 | |
| PIO Controller | 4.5 | |
| SPI | 9.5 | |
| SSC | 15.3 | |
| Timer Counter Channels | 3.0 | |
| TWI | 2.1 | |
| UDP | 8.9 | |
| UHP | 12.1 | |
| USART | 1.7 | |

38.4 Clock Characteristics

38.4.1 Processor Clock Characteristics

Table 38-5. Processor Clock Waveform Parameters

| Symbol | Parameter | Conditions | Min | Max | Unit |
|----------------|---------------------------|---|-----|-----|------|
| $1/(t_{CPCK})$ | Processor Clock Frequency | VDDCORE = 1.08V $T_A = 85^\circ\text{C}$ | – | 188 | MHz |

38.4.2 Master Clock Characteristics

Table 38-6. Master Clock Waveform Parameters

| Symbol | Parameter | Conditions | Min | Max | Unit |
|-----------------|------------------------|---|-----|-----|------|
| $1/(t_{CPMCK})$ | Master Clock Frequency | VDDCORE = 1.08V $T_A = 85^\circ\text{C}$ | – | 94 | MHz |

38.4.3 XIN Clock Characteristics

Table 38-7. XIN Clock Electrical Characteristics

| Symbol | Parameter | Conditions | Min | Max | Unit |
|-----------------|----------------------------|--|------------------------|------------------------|------------|
| $1/(t_{CPXIN})$ | XIN Clock Frequency | – | – | 50.0 | MHz |
| t_{CPXIN} | XIN Clock Period | – | 20.0 | – | ns |
| t_{CHXIN} | XIN Clock High Half-period | – | $0.4 \times t_{CPXIN}$ | $0.6 \times t_{CPXIN}$ | ns |
| t_{CLXIN} | XIN Clock Low Half-period | – | $0.4 \times t_{CPXIN}$ | $0.6 \times t_{CPXIN}$ | ns |
| C_{IN} | XIN Input Capacitance | Main Oscillator in Bypass mode (i.e., when MOSCEN = 0 and OSCBYPASS = 1 in CKGR_MOR) | – | 25 | pF |
| R_{IN} | XIN Pulldown Resistor | | – | 500 | k Ω |
| V_{IN} | XIN Voltage | | – | 3.3 | V |

38.5 Crystal Oscillator Characteristics

The following characteristics are applicable to the operating temperature range: $T_A = -40^{\circ}\text{C}$ to 85°C and worst case of power supply, unless otherwise specified.

38.5.1 32 kHz Oscillator Characteristics

Table 38-8. 32 kHz Oscillator Characteristics

| Symbol | Parameter | Conditions | Min | Typ | Max | Unit |
|--------------------|------------------------------|--|-----|--------|------|------|
| $1/(t_{CP32KHz})$ | Crystal Oscillator Frequency | – | – | 32.768 | – | kHz |
| $C_{CRYSTAL32}$ | Crystal Load Capacitance | Crystal @ 32.768 kHz | 6 | – | 12.5 | pF |
| $C_{LEXT32}^{(2)}$ | External Load Capacitance | $C_{CRYSTAL32} = 6 \text{ pF}^{(3)}$ | – | 4 | – | pF |
| | | $C_{CRYSTAL32} = 12.5 \text{ pF}^{(3)}$ | – | 17 | – | |
| – | Duty Cycle | – | 40 | – | 60 | % |
| t_{START} | Startup Time | $V_{DDBU} = 1.2\text{V}$ $R_S = 50 \text{ k}\Omega, C_L = 6 \text{ pF}^{(1)}$ | – | – | 400 | ms |
| | | $V_{DDBU} = 1.2\text{V}$ $R_S = 50 \text{ k}\Omega, C_L = 12.5 \text{ pF}^{(1)}$ | – | – | 900 | |
| | | $V_{DDBU} = 1.2\text{V}$ $R_S = 100 \text{ k}\Omega, C_L = 6 \text{ pF}^{(1)}$ | – | – | 600 | |
| | | $V_{DDBU} = 1.2\text{V}$ $R_S = 100 \text{ k}\Omega, C_L = 12.5 \text{ pF}^{(1)}$ | – | – | 1200 | |

- Notes:
- R_S is the equivalent series resistance, C_L is the equivalent load capacitance.
 - C_{LEXT32} is determined by taking into account internal parasitic and package load capacitance.
 - Additional user load capacitance should be subtracted from C_{LEXT32} .

Figure 38-2. 32 kHz Oscillator Schematic

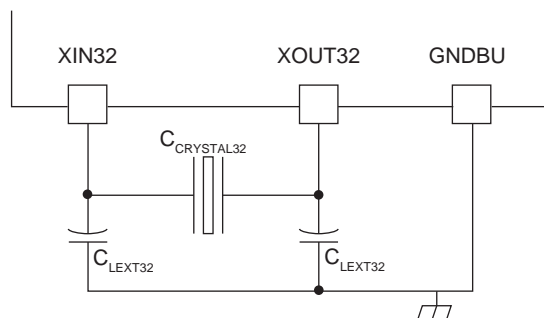

38.5.2 32 kHz Crystal Characteristics

Table 38-9. 32 kHz Crystal Characteristics

| Symbol | Parameter | Conditions | Min | Typ | Max | Unit |
|-------------|----------------------------------|----------------------|-----|-----|-----|------------------|
| ESR | Equivalent Series Resistor R_s | Crystal @ 32.768 kHz | – | 50 | 100 | $\text{k}\Omega$ |
| C_m | Motional Capacitance | Crystal @ 32.768 kHz | – | – | 3 | fF |
| C_{SHUNT} | Shunt Capacitance | Crystal @ 32.768 kHz | – | – | 2 | pF |

38.5.3 Main Oscillator Characteristics

Table 38-10. Main Oscillator Characteristics

| Symbol | Parameter | Conditions | Min | Typ | Max | Unit |
|------------------|------------------------------|---|------|--------------------------|--------------------------|---------------|
| $1/(t_{CPMAIN})$ | Crystal Oscillator Frequency | | 3 | 16 | 20 | MHz |
| $C_{CRYSTAL}$ | Crystal Load Capacitance | | 12.5 | 15 | 17.5 | pF |
| $C_{LEXT}^{(6)}$ | External Load Capacitance | $C_{CRYSTAL} = 12.5 \text{ pF}^{(5)}$ | – | 15 | – | pF |
| | | $C_{CRYSTAL} = 15 \text{ pF}^{(5)}$ | – | 18 | – | |
| | | $C_{CRYSTAL} = 17.5 \text{ pF}^{(5)}$ | – | 22 | – | |
| | Duty Cycle | | 40 | 50 | 60 | % |
| t_{START} | Startup Time | $V_{DDPLL} = 3 \text{ to } 3.6\text{V}$ $C_{SHUNT} = 3 \text{ pF}, 1/(t_{CPMAIN}) = 3 \text{ MHz}$ $C_{SHUNT} = 7 \text{ pF}, 1/(t_{CPMAIN}) = 8 \text{ MHz}$ $C_{SHUNT} = 7 \text{ pF}, 1/(t_{CPMAIN}) = 16 \text{ MHz}$ $C_{SHUNT} = 7 \text{ pF}, 1/(t_{CPMAIN}) = 20 \text{ MHz}$ | – | – | 20 4 2 2 | ms |
| I_{DDST} | Standby Current Consumption | Standby mode | – | – | 1 | μA |
| P_{ON} | Drive Level | @ 3 MHz @ 8 MHz @ 16 MHz @ 20 MHz | – | – | 15 30 50 50 | μW |
| I_{DDON} | Current Dissipation | @ 3 MHz ⁽¹⁾ @ 8 MHz ⁽²⁾ @ 16 MHz ⁽³⁾ @ 20 MHz ⁽⁴⁾ | – | 150 300 300 450 | 250 530 530 650 | μA |

- Notes: 1. $R_S = 100 \text{ to } 200 \ \Omega$; $C_{SHUNT} = 2.0 \text{ to } 2.5 \text{ pF}$; $C_m = 2 \text{ to } 1.5 \text{ fF}$ (typ, worst case) using 1 k Ω serial resistor on XOUT.
 2. $R_S = 50 \text{ to } 100 \ \Omega$; $C_{SHUNT} = 2.0 \text{ to } 2.5 \text{ pF}$; $C_m = 4 \text{ to } 3 \text{ fF}$ (typ, worst case).
 3. $R_S = 25 \text{ to } 50 \ \Omega$; $C_{SHUNT} = 2.5 \text{ to } 3.0 \text{ pF}$; $C_m = 7 \text{ to } 5 \text{ fF}$ (typ, worst case).
 4. $R_S = 20 \text{ to } 50 \ \Omega$; $C_{SHUNT} = 3.2 \text{ to } 4.0 \text{ pF}$; $C_m = 10 \text{ to } 8 \text{ fF}$ (typ, worst case).
 5. Additional user load capacitance should be subtracted from C_{LEXT} .
 6. C_{LEXT} is determined by taking into account internal parasitic and package load capacitance.

Figure 38-3. Main Oscillator Schematic

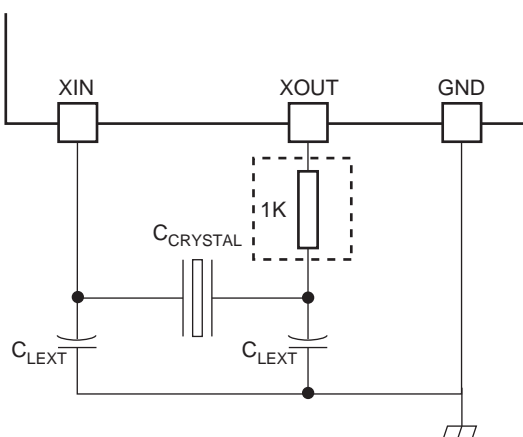

38.5.4 Crystal Characteristics

Table 38-11. Crystal Characteristics

| Symbol | Parameter | Conditions | Min | Typ | Max | Unit |
|-------------|----------------------------------|----------------------|-----|-----|-----|----------|
| ESR | Equivalent Series Resistor R_s | Fundamental @ 3 MHz | – | – | 200 | Ω |
| | | Fundamental @ 8 MHz | – | – | 100 | |
| | | Fundamental @ 16 MHz | – | – | 80 | |
| | | Fundamental @ 20 MHz | – | – | 50 | |
| C_m | Motional Capacitance | – | – | 8 | fF | |
| C_{SHUNT} | Shunt Capacitance | – | – | 7 | pF | |

38.5.5 PLL Characteristics

Table 38-12. Phase Lock Loop Characteristics

| Symbol | Parameter | Conditions | Min | Typ | Max | Unit |
|-----------|---------------------|-------------------|-----|-----|-----|---------|
| f_{OUT} | Output Frequency | CKGR_PLL.OUT = 00 | 80 | – | 200 | MHz |
| | | CKGR_PLL.OUT = 10 | 190 | – | 240 | |
| f_{IN} | Input Frequency | – | 1 | – | 32 | MHz |
| I_{PLL} | Current Consumption | Active mode | – | – | 3 | mA |
| | | Standby mode | – | – | 1 | μ A |

Note: Startup time depends on PLL RC filter. A calculation tool is provided by Atmel.

38.6 USB Transceiver Characteristics

38.6.1 Electrical Characteristics

Table 38-13. USB Transceiver Electrical Parameters

| Symbol | Parameter | Conditions | Min | Typ | Max | Unit |
|------------------|---|--|-------|-----|-------|------------|
| Input Levels | | | | | | |
| V_{IL} | Low Level | – | – | – | 0.8 | V |
| V_{IH} | High Level | – | 2.0 | – | – | V |
| V_{DI} | Differential Input Sensitivity | $ (D+) - (D-) $ | 0.2 | – | – | V |
| V_{CM} | Differential Input Common Mode Range | – | 0.8 | – | 2.5 | V |
| C_{IN} | Transceiver capacitance | Capacitance to ground on each line | – | – | 9.18 | pF |
| I_{IKg} | Hi-Z State Data Line Leakage | $0V < V_{IN} < 3.3V$ | - 10 | – | + 10 | μA |
| R_{EXT} | Recommended External USB Series Resistor | In series with each USB pin with $\pm 5\%$ | – | 27 | – | Ω |
| Output Levels | | | | | | |
| V_{OL} | Low Level Output | Measured with R_L of 1.425 k Ω tied to 3.6V | 0.0 | – | 0.3 | V |
| V_{OH} | High Level Output | Measured with R_L of 14.25 k Ω tied to GND | 2.8 | – | 3.6 | V |
| V_{CRS} | Output Signal Crossover Voltage | Measurement conditions described in Figure 38-13 | 1.3 | – | 2.0 | V |
| Pull-up Resistor | | | | | | |
| R_{PUI} | Bus Pull-up Resistor on Upstream Port (idle bus) | – | 0.900 | – | 1.575 | k Ω |
| R_{PUA} | Bus Pull-up Resistor on Upstream Port (upstream port receiving) | – | 1.425 | – | 3.090 | k Ω |

38.7 Core Power Supply POR Characteristics

Table 38-14. Power-On-Reset Characteristics

| Symbol | Parameter | Conditions | Min | Typ | Max | Unit |
|-----------|---------------------------|--------------------------|-----|-----|------|---------|
| V_{T+} | Threshold Voltage Rising | Minimum Slope of 7.6V/ms | 0.7 | 0.9 | 1.08 | V |
| V_{T-} | Threshold Voltage Falling | – | 0.6 | 0.8 | 1.0 | V |
| t_{RST} | Reset Time | – | 50 | 170 | 300 | μs |

38.8 EBI Timings

These timings are given for

- Worst case process
- $T_A = 85^\circ\text{C}$
- VDDCORE = Min
- 1.8V VDDIOM supply: range 1.65–1.95 V, 30 pF load capacitance
- 3.3V VDDIOM supply: range 3.0–3.6 V, 50 pF load capacitance

Table 38-15. SMC Read Signals with Hold Settings

| Symbol | Parameter | Min | | | | Unit |
|---------------------------------------|---|--|--|--|--|------|
| | | 1.8V VDDIOM Supply | | 3.3V VDDIOM Supply | | |
| | | 1.08V VDDCORE Supply | 1.2V VDDCORE Supply | 1.08V VDDCORE Supply | 1.2V VDDCORE Supply | |
| NRD Controlled (READ_MODE = 1) | | | | | | |
| SMC ₁ | Data Setup before NRD High | 13.5 | 10.6 | 10.7 | 8.5 | ns |
| SMC ₂ | Data Hold after NRD High | 0 | 0 | 0 | 0 | ns |
| SMC ₃ | NRD High to NBS0/A0 Change ⁽¹⁾ | nrd hold length * $t_{\text{CPMCK}} + 0.2$ | nrd hold length * $t_{\text{CPMCK}} + 0.2$ | nrd hold length * $t_{\text{CPMCK}} + 0.2$ | nrd hold length * $t_{\text{CPMCK}} + 0.2$ | ns |
| SMC ₄ | NRD High to NBS1 Change ⁽¹⁾ | nrd hold length * $t_{\text{CPMCK}} + 0.2$ | nrd hold length * $t_{\text{CPMCK}} + 0.2$ | nrd hold length * $t_{\text{CPMCK}} + 0.1$ | nrd hold length * $t_{\text{CPMCK}} + 0.1$ | ns |
| SMC ₅ | NRD High to NBS2/A1 Change ⁽¹⁾ | nrd hold length * $t_{\text{CPMCK}} + 0.2$ | nrd hold length * $t_{\text{CPMCK}} + 0.2$ | nrd hold length * $t_{\text{CPMCK}} + 0.2$ | nrd hold length * $t_{\text{CPMCK}} + 0.2$ | ns |
| SMC ₆ | NRD High to NBS3 Change ⁽¹⁾ | nrd hold length * $t_{\text{CPMCK}} + 0.1$ | nrd hold length * $t_{\text{CPMCK}} + 0.1$ | nrd hold length * $t_{\text{CPMCK}} + 0.1$ | nrd hold length * $t_{\text{CPMCK}} + 0.1$ | ns |
| SMC ₇ | NRD High to A2–A25 Change ⁽¹⁾ | nrd hold length * $t_{\text{CPMCK}} - 0.5$ | nrd hold length * $t_{\text{CPMCK}} - 0.5$ | nrd hold length * $t_{\text{CPMCK}} - 0.7$ | nrd hold length * $t_{\text{CPMCK}} - 0.5$ | ns |
| SMC ₈ | NRD High to NCS Inactive ⁽¹⁾ | (nrd hold length - ncs rd hold length) * $t_{\text{CPMCK}} -$ 0.4 | (nrd hold length - ncs rd hold length) * $t_{\text{CPMCK}} -$ 0.3 | (nrd hold length - ncs rd hold length) * $t_{\text{CPMCK}} -$ 0.4 | (nrd hold length - ncs rd hold length) * $t_{\text{CPMCK}} -$ 0.3 | ns |
| SMC ₉ | NRD Pulse Width | nrd pulse length * $t_{\text{CPMCK}} - 0.2$ | nrd pulse length * $t_{\text{CPMCK}} - 0.2$ | nrd pulse length * $t_{\text{CPMCK}} + 0.1$ | nrd pulse length * $t_{\text{CPMCK}} - 0.0$ | ns |

Table 38-15. SMC Read Signals with Hold Settings (Continued)

| Symbol | Parameter | Min | | | | Unit |
|---------------------------------------|---|---|---|---|---|------|
| | | 1.8V VDDIOM Supply | | 3.3V VDDIOM Supply | | |
| | | 1.08V VDDCORE Supply | 1.2V VDDCORE Supply | 1.08V VDDCORE Supply | 1.2V VDDCORE Supply | |
| NCS Controlled (READ_MODE = 0) | | | | | | |
| SMC ₁₀ | Data Setup before NCS High | 16.5 | 12.7 | 13.6 | 10.6 | ns |
| SMC ₁₁ | Data Hold after NCS High | 0 | 0 | 0 | 0 | ns |
| SMC ₁₂ | NCS High to NBS0/A0 Change ⁽¹⁾ | ncs rd hold length * t _{CPMCK} - 2.6 | ncs rd hold length * t _{CPMCK} - 1.8 | ncs rd hold length * t _{CPMCK} - 2.6 | ncs rd hold length * t _{CPMCK} - 1.8 | ns |
| SMC ₁₃ | NCS High to NBS1 Change ⁽¹⁾ | ncs rd hold length * t _{CPMCK} - 2.4 | ncs rd hold length * t _{CPMCK} - 1.7 | ncs rd hold length * t _{CPMCK} - 2.5 | ncs rd hold length * t _{CPMCK} - 1.8 | ns |
| SMC ₁₄ | NCS High to NBS2/A1 Change ⁽¹⁾ | ncs rd hold length * t _{CPMCK} - 2.5 | ncs rd hold length * t _{CPMCK} - 1.7 | ncs rd hold length * t _{CPMCK} - 2.6 | ncs rd hold length * t _{CPMCK} - 1.8 | ns |
| SMC ₁₅ | NCS High to NBS3 Change ⁽¹⁾ | ncs rd hold length * t _{CPMCK} - 2.6 | ncs rd hold length * t _{CPMCK} - 1.9 | ncs rd hold length * t _{CPMCK} - 2.6 | ncs rd hold length * t _{CPMCK} - 1.9 | ns |
| SMC ₁₆ | NCS High to A2–A25 Change ⁽¹⁾ | ncs rd hold length * t _{CPMCK} - 3.5 | ncs rd hold length * t _{CPMCK} - 2.6 | ncs rd hold length * t _{CPMCK} - 3.6 | ncs rd hold length * t _{CPMCK} - 2.6 | ns |
| SMC ₁₇ | NCS High to NRD Inactive ⁽¹⁾ | (ncs rd hold length - nrd hold length) * t _{CPMCK} - 2.9 | (ncs rd hold length - nrd hold length) * t _{CPMCK} - 2.1 | (ncs rd hold length - nrd hold length) * t _{CPMCK} - 2.9 | (ncs rd hold length - nrd hold length) * t _{CPMCK} - 2.1 | ns |
| SMC ₁₈ | NCS Pulse Width | ncs rd pulse length * t _{CPMCK} - 2.7 | ncs rd pulse length * t _{CPMCK} - 2.0 | ncs rd pulse length * t _{CPMCK} - 2.5 | ncs rd pulse length * t _{CPMCK} - 1.8 | ns |

Note: 1. hold length = total cycle duration - setup duration - pulse duration. “hold length” is for “ncs rd hold length” or “nrd hold length”.

Table 38-16. SMC Read Signals with No Hold Settings

| Symbol | Parameter | Min | | | | Unit |
|---------------------------------------|----------------------------|----------------------|---------------------|----------------------|---------------------|------|
| | | 1.8V VDDIOM Supply | | 3.3V VDDIOM Supply | | |
| | | 1.08V VDDCORE Supply | 1.2V VDDCORE Supply | 1.08V VDDCORE Supply | 1.2V VDDCORE Supply | |
| NRD Controlled (READ_MODE = 1) | | | | | | |
| SMC ₁₉ | Data Setup before NRD High | 16.1 | 12.4 | 13.1 | 10.2 | ns |
| SMC ₂₀ | Data Hold after NRD High | 0 | 0 | 0 | 0 | ns |
| NCS Controlled (READ_MODE = 0) | | | | | | |
| SMC ₂₁ | Data Setup before NCS High | 19.0 | 14.5 | 16.0 | 12.3 | ns |
| SMC ₂₂ | Data Hold after NCS High | 0 | 0 | 0 | 0 | ns |

Table 38-17. SMC Write Signals with Hold Settings

| Symbol | Parameter | Min | | | | Unit |
|--|--|---|---|---|---|------|
| | | 1.8V VDDIOM Supply | | 3.3V VDDIOM Supply | | |
| | | 1.08V VDDCORE Supply | 1.2V VDDCORE Supply | 1.08V VDDCORE Supply | 1.2V VDDCORE Supply | |
| NWE Controlled (WRITE_MODE = 1) | | | | | | |
| SMC ₂₃ | Data Out Valid before NWE High | (NWE pulse length) * t _{CPMCK} - 3.8 | (NWE pulse length) * t _{CPMCK} - 2.9 | (NWE pulse length) * t _{CPMCK} - 2.7 | (NWE pulse length) * t _{CPMCK} - 2.1 | ns |
| SMC ₂₄ | Data Out Valid after NWE High ⁽¹⁾ | NWE hold length * t _{CPMCK} - 5.0 | NWE hold length * t _{CPMCK} - 4.1 | NWE hold length * t _{CPMCK} - 3.7 | NWE hold length * t _{CPMCK} - 3.1 | ns |
| SMC ₂₅ | NWE High to NBS0/A0 Change ⁽¹⁾ | NWE hold length * t _{CPMCK} - 0.2 | NWE hold length * t _{CPMCK} - 0.1 | NWE hold length * t _{CPMCK} - 0.2 | NWE hold length * t _{CPMCK} - 0.1 | ns |
| SMC ₂₆ | NWE High to NBS1 Change ⁽¹⁾ | NWE hold length * t _{CPMCK} - 0.1 | NWE hold length * t _{CPMCK} - 0.1 | NWE hold length * t _{CPMCK} - 0.1 | NWE hold length * t _{CPMCK} - 0.1 | ns |
| SMC ₂₉ | NWE High to NBS2/A1 Change ⁽¹⁾ | NWE hold length * t _{CPMCK} - 0.1 | NWE hold length * t _{CPMCK} - 0.0 | NWE hold length * t _{CPMCK} - 0.2 | NWE hold length * t _{CPMCK} - 0.1 | ns |
| SMC ₃₀ | NWE High to NBS3 Change ⁽¹⁾ | NWE hold length * t _{CPMCK} - 0.2 | NWE hold length * t _{CPMCK} - 0.2 | NWE hold length * t _{CPMCK} - 0.2 | NWE hold length * t _{CPMCK} - 0.2 | ns |
| SMC ₃₁ | NWE High to A2–A25 Change ⁽¹⁾ | NWE hold length * t _{CPMCK} - 1.0 | NWE hold length * t _{CPMCK} - 0.9 | NWE hold length * t _{CPMCK} - 1.2 | NWE hold length * t _{CPMCK} - 0.8 | ns |
| SMC ₃₂ | NWE High to NCS Inactive ⁽¹⁾ | (NWE hold length - ncs wr hold length) * t _{CPMCK} - 0.9 | (NWE hold length - ncs wr hold length) * t _{CPMCK} - 0.7 | (NWE hold length - ncs wr hold length) * t _{CPMCK} - 0.9 | (NWE hold length - ncs wr hold length) * t _{CPMCK} - 0.7 | ns |
| SMC ₃₃ | NWE Pulse Width | NWE pulse length * t _{CPMCK} - 0.4 | NWE pulse length * t _{CPMCK} - 0.3 | NWE pulse length * t _{CPMCK} - 0.1 | NWE pulse length * t _{CPMCK} - 0.1 | ns |
| NCS Controlled (WRITE_MODE = 0) | | | | | | |
| SMC ₃₄ | Data Out Valid before NCS High | (ncs wr pulse length) * t _{CPMCK} - 4.7 | (ncs wr pulse length) * t _{CPMCK} - 3.6 | (ncs wr pulse length) * t _{CPMCK} - 3.6 | (ncs wr pulse length) * t _{CPMCK} - 2.7 | ns |
| SMC ₃₅ | Data Out Valid after NCS High ⁽¹⁾ | ncs wr hold length * t _{CPMCK} - 7.5 | ncs wr hold length * t _{CPMCK} - 5.8 | ncs wr hold length * t _{CPMCK} - 6.2 | ncs wr hold length * t _{CPMCK} - 4.9 | ns |
| SMC ₃₆ | NCS High to NWE Inactive ⁽¹⁾ | (ncs wr hold length - NWE hold length) * t _{CPMCK} - 2.6 | (ncs wr hold length - NWE hold length) * t _{CPMCK} - 1.9 | (ncs wr hold length - NWE hold length) * t _{CPMCK} - 2.6 | (ncs wr hold length - NWE hold length) * t _{CPMCK} - 1.9 | ns |

Note: 1. hold length = total cycle duration - setup duration - pulse duration. “hold length” is for “ncs wr hold length” or “NWE hold length”.

Table 38-18. SMC Write Signals with No Hold Settings (NWE Controlled Only)

| Symbol | Parameter | Min | | | | Unit |
|-------------------|----------------------------------|--|--|--|--|------|
| | | 1.8V VDDIOM Supply | | 3.3V VDDIOM Supply | | |
| | | 1.08V VDDCORE Supply | 1.2V VDDCORE Supply | 1.08V VDDCORE Supply | 1.2V VDDCORE Supply | |
| SMC ₃₇ | NWE Rising to A2–A25 Valid | 3.2 | 3.2 | 2.6 | 2.6 | ns |
| SMC ₃₈ | NWE Rising to NBS0/A0 Valid | 3.2 | 3.2 | 2.6 | 2.6 | ns |
| SMC ₃₉ | NWE Rising to NBS1 Change | 3.1 | 3.1 | 2.5 | 2.5 | ns |
| SMC ₄₀ | NWE Rising to A1/NBS2 Change | 3.3 | 3.3 | 2.7 | 2.7 | ns |
| SMC ₄₁ | NWE Rising to NBS3 Change | 3.1 | 3.1 | 2.5 | 2.5 | ns |
| SMC ₄₂ | NWE Rising to NCS Rising | 3.1 | 3.1 | 2.5 | 2.5 | ns |
| SMC ₄₃ | Data Out Valid before NWE Rising | (NWE pulse length) * $t_{CPMCK} - 3.8$ | (NWE pulse length) * $t_{CPMCK} - 2.9$ | (NWE pulse length) * $t_{CPMCK} - 2.7$ | (NWE pulse length) * $t_{CPMCK} - 2.1$ | ns |
| SMC ₄₄ | Data Out Valid after NWE Rising | 2.8 | 2.8 | 2.5 | 2.5 | ns |
| SMC ₄₅ | NWE Pulse Width | NWE pulse length * $t_{CPMCK} - 0.4$ | NWE pulse length * $t_{CPMCK} - 0.3$ | NWE pulse length * $t_{CPMCK} - 0.1$ | NWE pulse length * $t_{CPMCK} - 0.1$ | ns |

Figure 38-4. SMC NCS Controlled Access

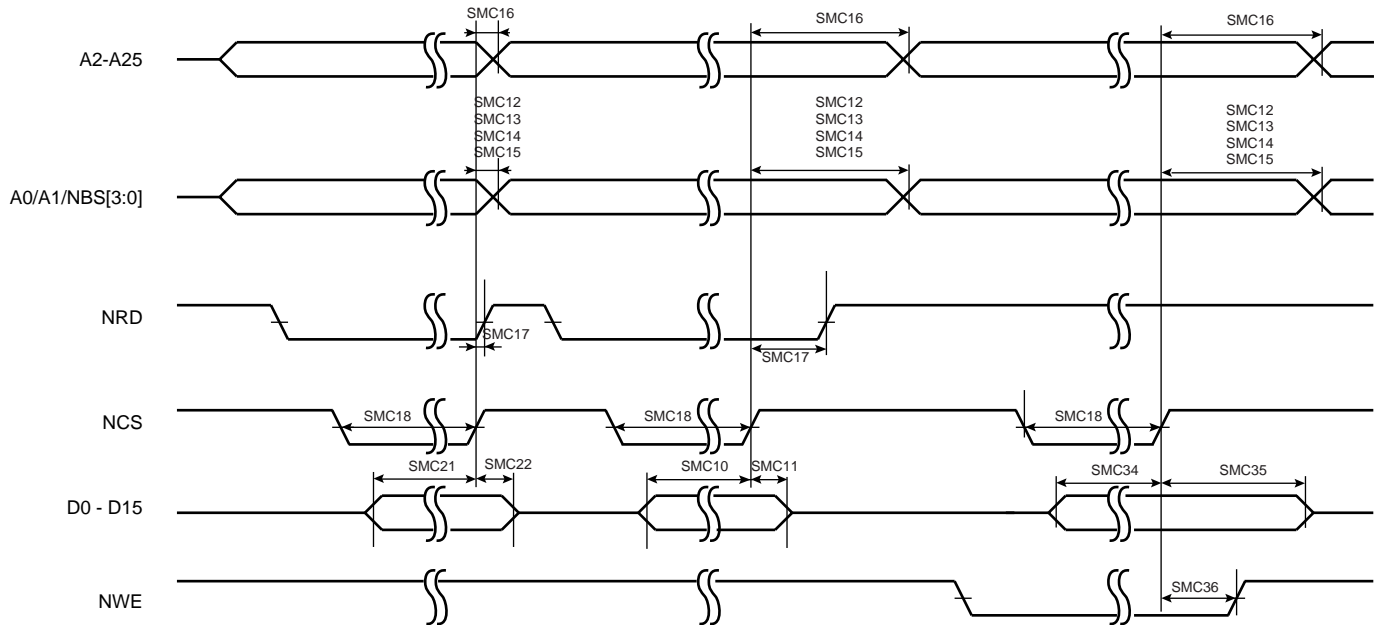
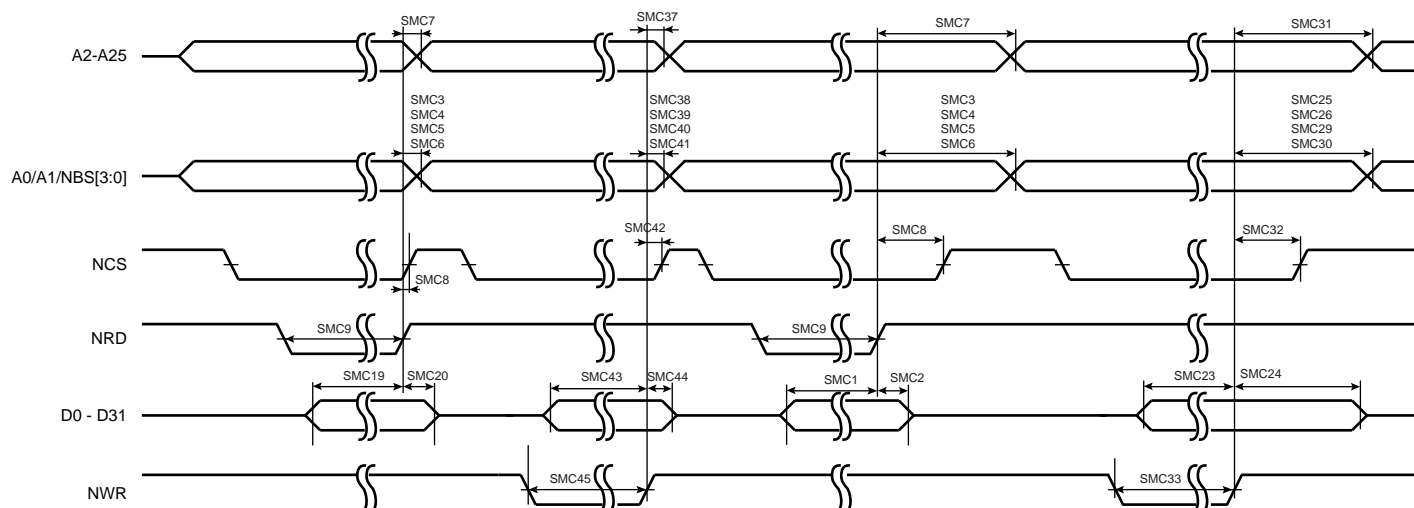

Figure 38-5. SMC Signals for NRD and NWR Controlled Access



38.9 SDRAMC Timings

The timings that follow are given for a 10 pF load on SDCK and 50 pF on the databus.

Table 38-19. SDRAMC Clock Signal

| Symbol | Parameter | Max | | Unit |
|-------------------------|----------------------------------|---|-------------|------|
| | | 1.8V Supply | 3.3V Supply | |
| $1/(t_{\text{CPSDCK}})$ | SDRAM Controller Clock Frequency | MCK Maximum Clock Frequency (See Table 38-6 , "Master Clock Waveform Parameters") | | MHz |

Table 38-20. SDRAM Signals

| Symbol | Parameter | Min | | Unit |
|----------------------|--|-----------------------------|-----------------------------|------|
| | | 1.8V Supply | 3.3V Supply | |
| SDRAMC ₁ | SDCKE High before SDCK Rising Edge | $t_{\text{CPSDCK}}/2 - 0.8$ | $t_{\text{CPSDCK}}/2 - 0.8$ | ns |
| SDRAMC ₂ | SDCKE Low after SDCK Rising Edge | $t_{\text{CPSDCK}}/2 - 0.3$ | $t_{\text{CPSDCK}}/2 - 0.4$ | ns |
| SDRAMC ₃ | SDCKE Low before SDCK Rising Edge | $t_{\text{CPSDCK}}/2 - 0.4$ | $t_{\text{CPSDCK}}/2 - 0.2$ | ns |
| SDRAMC ₄ | SDCKE High after SDCK Rising Edge | $t_{\text{CPSDCK}}/2 - 0.2$ | $t_{\text{CPSDCK}}/2 - 0.2$ | ns |
| SDRAMC ₅ | SDCS Low before SDCK Rising Edge | $t_{\text{CPSDCK}}/2 - 1.5$ | $t_{\text{CPSDCK}}/2 - 1.2$ | ns |
| SDRAMC ₆ | SDCS High after SDCK Rising Edge | $t_{\text{CPSDCK}}/2 - 0.3$ | $t_{\text{CPSDCK}}/2 - 0.3$ | ns |
| SDRAMC ₇ | RAS Low before SDCK Rising Edge | $t_{\text{CPSDCK}}/2 - 0.4$ | $t_{\text{CPSDCK}}/2 - 0.2$ | ns |
| SDRAMC ₈ | RAS High after SDCK Rising Edge | $t_{\text{CPSDCK}}/2 - 0.4$ | $t_{\text{CPSDCK}}/2 - 0.4$ | ns |
| SDRAMC ₉ | SDA10 Change before SDCK Rising Edge | $t_{\text{CPSDCK}}/2 - 0.4$ | $t_{\text{CPSDCK}}/2 - 0.5$ | ns |
| SDRAMC ₁₀ | SDA10 Change after SDCK Rising Edge | $t_{\text{CPSDCK}}/2 - 0.3$ | $t_{\text{CPSDCK}}/2 - 0.4$ | ns |
| SDRAMC ₁₁ | Address Change before SDCK Rising Edge | $t_{\text{CPSDCK}}/2 - 3.6$ | $t_{\text{CPSDCK}}/2 - 3.7$ | ns |
| SDRAMC ₁₂ | Address Change after SDCK Rising Edge | $t_{\text{CPSDCK}}/2 - 0.4$ | $t_{\text{CPSDCK}}/2 - 0.5$ | ns |
| SDRAMC ₁₃ | Bank Change before SDCK Rising Edge | $t_{\text{CPSDCK}}/2 - 3.3$ | $t_{\text{CPSDCK}}/2 - 3.3$ | ns |
| SDRAMC ₁₄ | Bank Change after SDCK Rising Edge | $t_{\text{CPSDCK}}/2 - 0.5$ | $t_{\text{CPSDCK}}/2 - 0.5$ | ns |

Table 38-20. SDRAM Signals (Continued)

| Symbol | Parameter | Min | | Unit |
|----------------------|---|-----------------------------|-----------------------------|------|
| | | 1.8V Supply | 3.3V Supply | |
| SDRAMC ₁₅ | CAS Low before SDCK Rising Edge | $t_{\text{CPSDCK}}/2 - 0.4$ | $t_{\text{CPSDCK}}/2 - 0.2$ | ns |
| SDRAMC ₁₆ | CAS High after SDCK Rising Edge | $t_{\text{CPSDCK}}/2 - 0.3$ | $t_{\text{CPSDCK}}/2 - 0.3$ | ns |
| SDRAMC ₁₇ | DQM Change before SDCK Rising Edge | $t_{\text{CPSDCK}}/2 - 3.4$ | $t_{\text{CPSDCK}}/2 - 3.3$ | ns |
| SDRAMC ₁₈ | DQM Change after SDCK Rising Edge | $t_{\text{CPSDCK}}/2 - 0.5$ | $t_{\text{CPSDCK}}/2 - 0.5$ | ns |
| SDRAMC ₁₉ | D0–D15 in Setup before SDCK Rising Edge | 1.4 | 1.4 | ns |
| SDRAMC ₂₀ | D0–D15 in Hold after SDCK Rising Edge | 0.1 | 0.0 | ns |
| SDRAMC ₂₁ | D16–D31 in Setup before SDCK Rising Edge | 1.8 | 1.8 | ns |
| SDRAMC ₂₂ | D16–D31 in Hold after SDCK Rising Edge | 0.0 | 0.0 | ns |
| SDRAMC ₂₃ | SDWE Low before SDCK Rising Edge | $t_{\text{CPSDCK}}/2 - 0.2$ | $t_{\text{CPSDCK}}/2 - 0.1$ | ns |
| SDRAMC ₂₄ | SDWE High after SDCK Rising Edge | $t_{\text{CPSDCK}}/2 - 0.4$ | $t_{\text{CPSDCK}}/2 - 0.4$ | ns |
| SDRAMC ₂₅ | D0–D15 Out Valid before SDCK Rising Edge | $t_{\text{CPSDCK}}/2 - 1.3$ | $t_{\text{CPSDCK}}/2 - 1.1$ | ns |
| SDRAMC ₂₆ | D0–D15 Out Valid after SDCK Rising Edge | $t_{\text{CPSDCK}}/2 - 0.6$ | $t_{\text{CPSDCK}}/2 - 0.6$ | ns |
| SDRAMC ₂₇ | D16–D31 Out Valid before SDCK Rising Edge | $t_{\text{CPSDCK}}/2 - 3.9$ | $t_{\text{CPSDCK}}/2 - 3.9$ | ns |
| SDRAMC ₂₈ | D16–D31 Out Valid after SDCK Rising Edge | $t_{\text{CPSDCK}}/2 - 0.5$ | $t_{\text{CPSDCK}}/2 - 0.5$ | ns |

Figure 38-6. SDRAM Signals Relative to SDCK

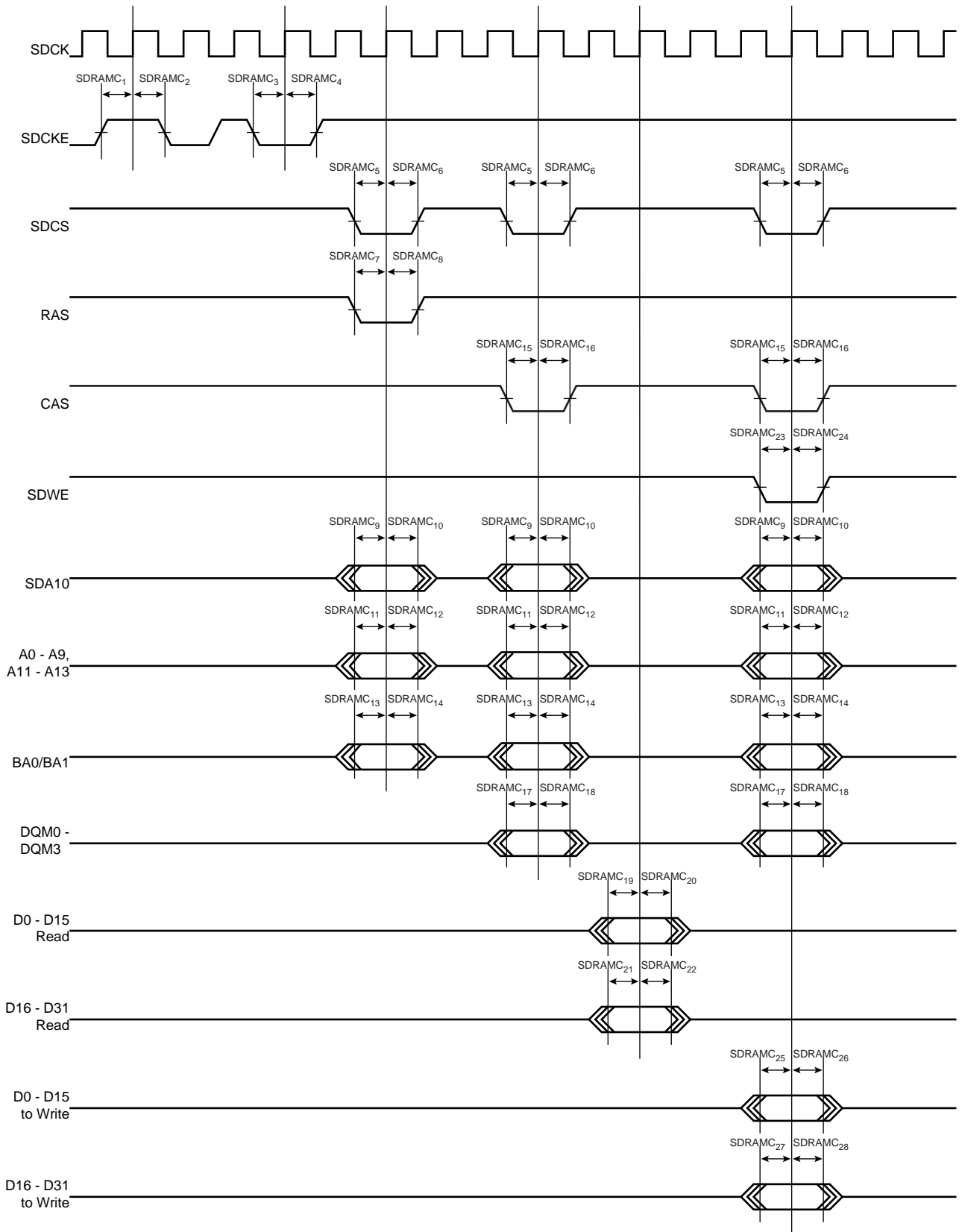

38.10 Peripheral Timings

38.10.1 SPI

38.10.1.1 Maximum SPI Frequency

The following formulas give maximum SPI frequency in Master read and write modes and in Slave read and write modes.

Master Write Mode

The SPI only sends data to a slave device such as an LCD, for example. The limit is given by SPI₂ (or SPI₅) timing. Since it gives a maximum frequency above the maximum pad speed, the maximum SPI frequency is the one from the pad.

Master Read Mode

$$f_{SPCK}^{Max} = \frac{1}{SPI_0(orSPI_3) + t_{valid}}$$

t_{valid} is the slave time response to output data after deleting an SPCK edge. For a non-volatile memory with t_{valid} (or t_v) = 12 ns, $f_{SPCK}^{max} = 35.4$ MHz at $V_{DDIO} = 3.3V$.

Slave Read Mode

In slave mode, SPCK is the input clock for the SPI. The maximum SPCK frequency is given by setup and hold timings SPI₇/SPI₈ (or SPI₁₀/SPI₁₁). Since this gives a frequency well above the pad limit, the limit in slave read mode is given by the SPCK pad.

Slave Write Mode

$$f_{SPCK}^{Max} = \frac{1}{SPI_6(orSPI_9) + t_{setup}}$$

For 3.3V I/O domain and SPI6, $f_{SPCK}^{Max} = 33$ MHz. t_{setup} is the setup time from the master before sampling data.

38.10.1.2 Timing Conditions

Timings are given assuming a capacitance load on MISO, SPCK and MOSI as defined in [Table 38-21](#).

Table 38-21. Capacitance Load for MISO, SPCK and MOSI

| IO Supply | Corner |
|-----------|--------|
| | MAX |
| 3.3V | 40 pF |
| 1.8V | 20 pF |

38.10.1.3 Timing Extraction

In [Figure 38-8 "SPI Master mode with \(CPOL = 0 and NCPHA = 1\) or \(CPOL = 1 and NCPHA = 0\)"](#) and [Figure 38-9 "SPI Master mode with \(CPOL = NCPHA = 0\) or \(CPOL = NCPHA = 1\)"](#) the MOSI line shifting edge is represented with a hold time = 0. However, it is important to note that for this device, the MISO line is sampled prior to the MOSI line shifting edge. As shown in [Figure 38-7 "MISO Capture in Master Mode"](#), the device sampling point extends the propagation delay (t_p) for slave and routing delays to more than half the SPI clock period, whereas the common sampling point allows only less than half the SPI clock period.

As an example, an SPI Slave working in Mode 0 is safely driven if the SPI Master is configured in Mode 0.

Figure 38-7. MISO Capture in Master Mode

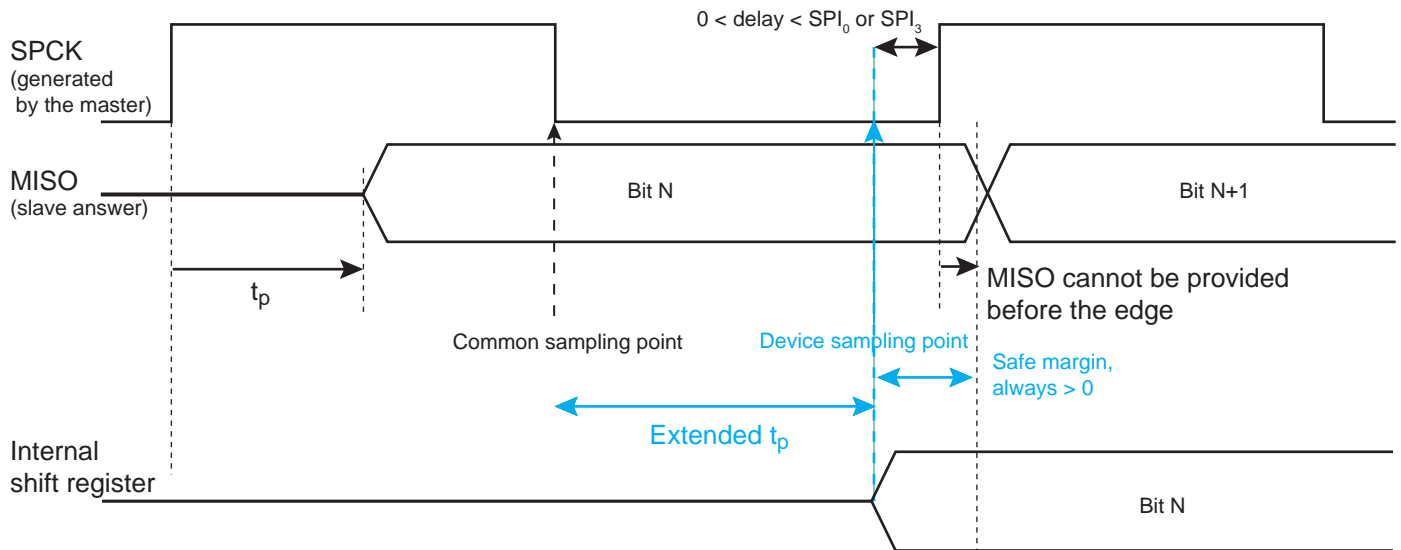

Figure 38-8. SPI Master mode with (CPOL = 0 and NCPHA = 1) or (CPOL = 1 and NCPHA = 0)

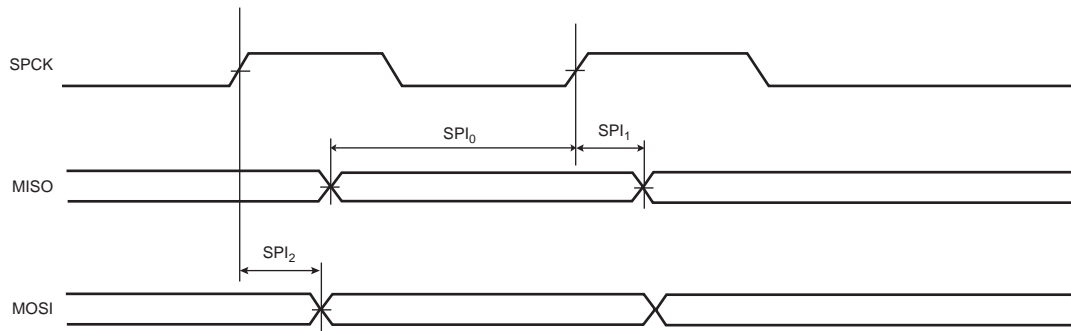

Figure 38-9. SPI Master mode with (CPOL = NCPHA = 0) or (CPOL = NCPHA = 1)

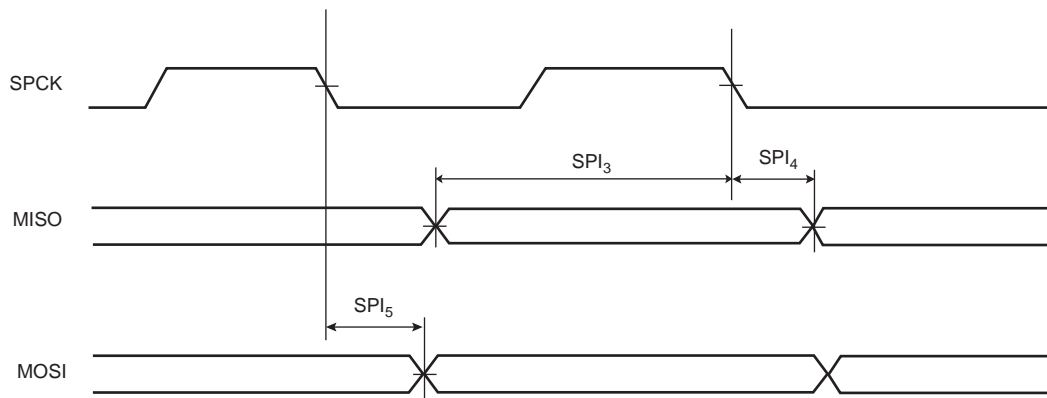

Figure 38-10. SPI Slave mode with (CPOL = 0 and NCPHA = 1) or (CPOL = 1 and NCPHA = 0)

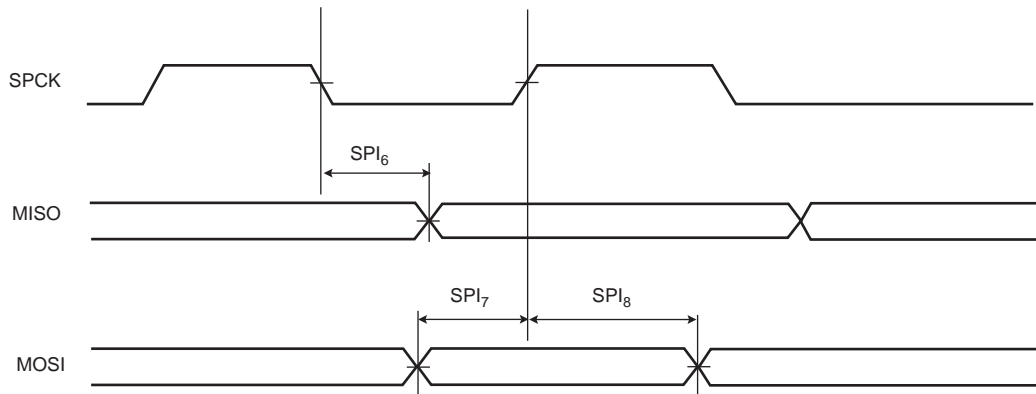

Figure 38-11. SPI Slave mode with (CPOL = NCPHA = 0) or (CPOL = NCPHA = 1)

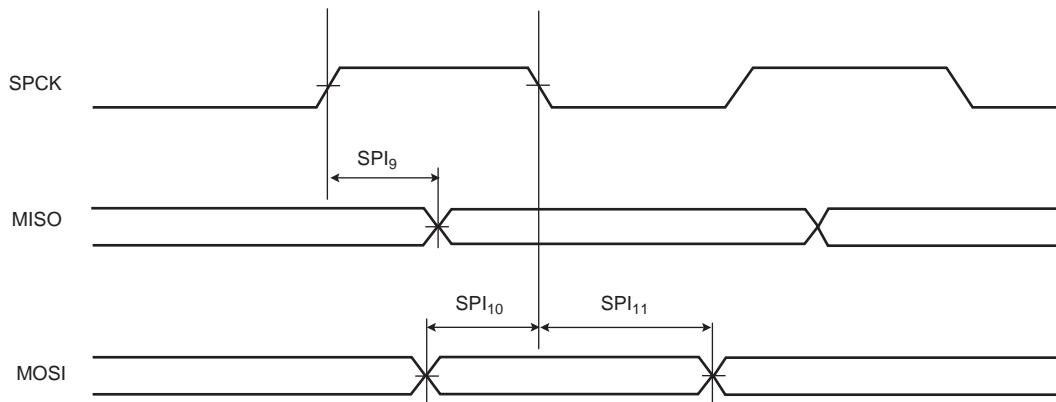

Table 38-22. SPI Timings

| Symbol | Parameter | Conditions | Min | Max | Unit |
|--------------------|-----------------------------------|------------|--------------------------|-----|------|
| Master Mode | | | | | |
| SPI ₀ | MISO Setup time before SPCK rises | MAX corner | $14.2 + 0.5 * t_{CPMCK}$ | – | ns |
| SPI ₁ | MISO Hold time after SPCK rises | | $-3.5 - 0.5 * t_{CPMCK}$ | – | ns |
| SPI ₂ | SPCK rising to MOSI | | 0.4 | – | ns |
| SPI ₃ | MISO Setup time before SPCK falls | | $14.4 + 0.5 * t_{CPMCK}$ | – | ns |
| SPI ₄ | MISO Hold time after SPCK falls | | $-3.5 - 0.5 * t_{CPMCK}$ | – | ns |
| SPI ₅ | SPCK falling to MOSI | | 0.5 | – | ns |
| Slave Mode | | | | | |
| SPI ₆ | SPCK falling to MISO | MAX corner | 11.4 | – | ns |
| SPI ₇ | MOSI Setup time before SPCK rises | | 1.1 | – | ns |
| SPI ₈ | MOSI Hold time after SPCK rises | | -0.1 | – | ns |
| SPI ₉ | SPCK rising to MISO | | 11.4 | – | ns |
| SPI ₁₀ | MOSI Setup time before SPCK falls | | 1.0 | – | ns |
| SPI ₁₁ | MOSI Hold time after SPCK falls | | 0.0 | – | ns |

38.10.2 MCI

The PDC interface block controls all data routing between the external data bus, internal MMC/SD module data bus, and internal system FIFO access through a dedicated state machine that monitors the status of FIFO content (empty or full), FIFO address, and byte/block counters for the MMC/SD module (inner system) and the application (user programming).

These timings are given for a 25 pF load, corresponding to one MMC/SD Card.

Figure 38-12. MCI Timing Diagram

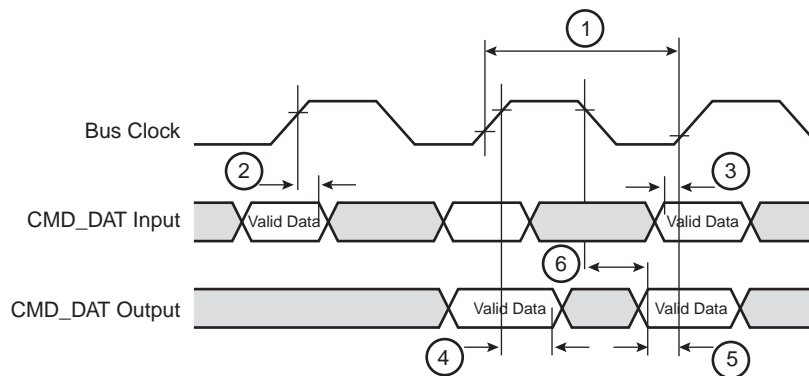

Table 38-23. MCI Timings

| Symbol | Parameter | Min | Max | Unit |
|----------------------|--|--------------------------|-----|------|
| $1/t_{\text{CLOCK}}$ | CLK frequency at Data transfer Mode (PP) | 0 | 50 | MHz |
| 2 | Input hold time | 0.9 | – | ns |
| 3 | Input setup time | 0.2 | – | ns |
| 4 | Output hold time | 8.5 | – | ns |
| 5 | Output setup time | $t_{\text{CLOCK}} - 2.1$ | – | ns |

38.10.3 UDP and UHP Switching Characteristics

Figure 38-13. USB Data Signal Timing Diagram

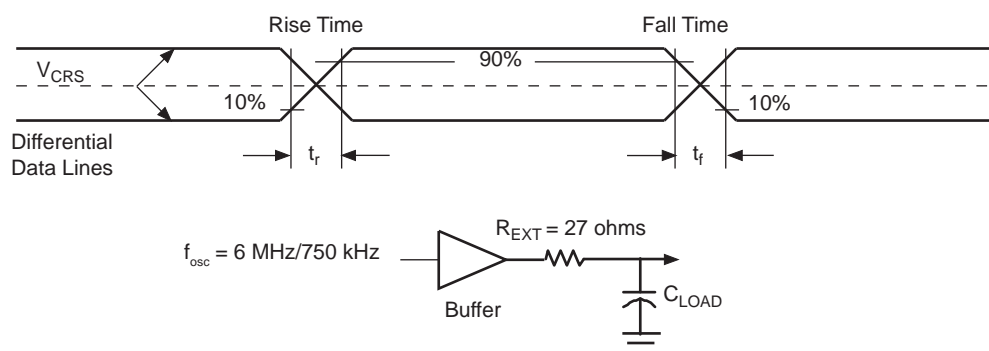

Table 38-24. USB Data Signal Rise and Fall Time Characteristics (Low Speed)

| Symbol | Parameter | Conditions | Min | Typ | Max | Unit |
|-----------|-------------------------|-----------------------------|-----|-----|-----|------|
| t_r | Transition Rise Time | $C_{LOAD} = 400 \text{ pF}$ | 75 | – | 300 | ns |
| t_f | Transition Fall Time | $C_{LOAD} = 400 \text{ pF}$ | 75 | – | 300 | ns |
| t_{rfm} | Rise/Fall time Matching | $C_{LOAD} = 400 \text{ pF}$ | 80 | – | 125 | % |

Table 38-25. USB Data Signal Rise and Fall Time Characteristics (Full Speed)

| Symbol | Parameter | Conditions | Min | Typ | Max | Unit |
|-----------|-------------------------|----------------------------|-----|-----|--------|------|
| t_r | Transition Rise Time | $C_{LOAD} = 50 \text{ pF}$ | 4 | – | 20 | ns |
| t_f | Transition Fall Time | $C_{LOAD} = 50 \text{ pF}$ | 4 | – | 20 | ns |
| t_{rfm} | Rise/Fall time Matching | – | 90 | – | 111.11 | % |

39. Mechanical Characteristics

39.1 Package Drawings

Figure 39-1. 217-ball LFBGA Package Drawing

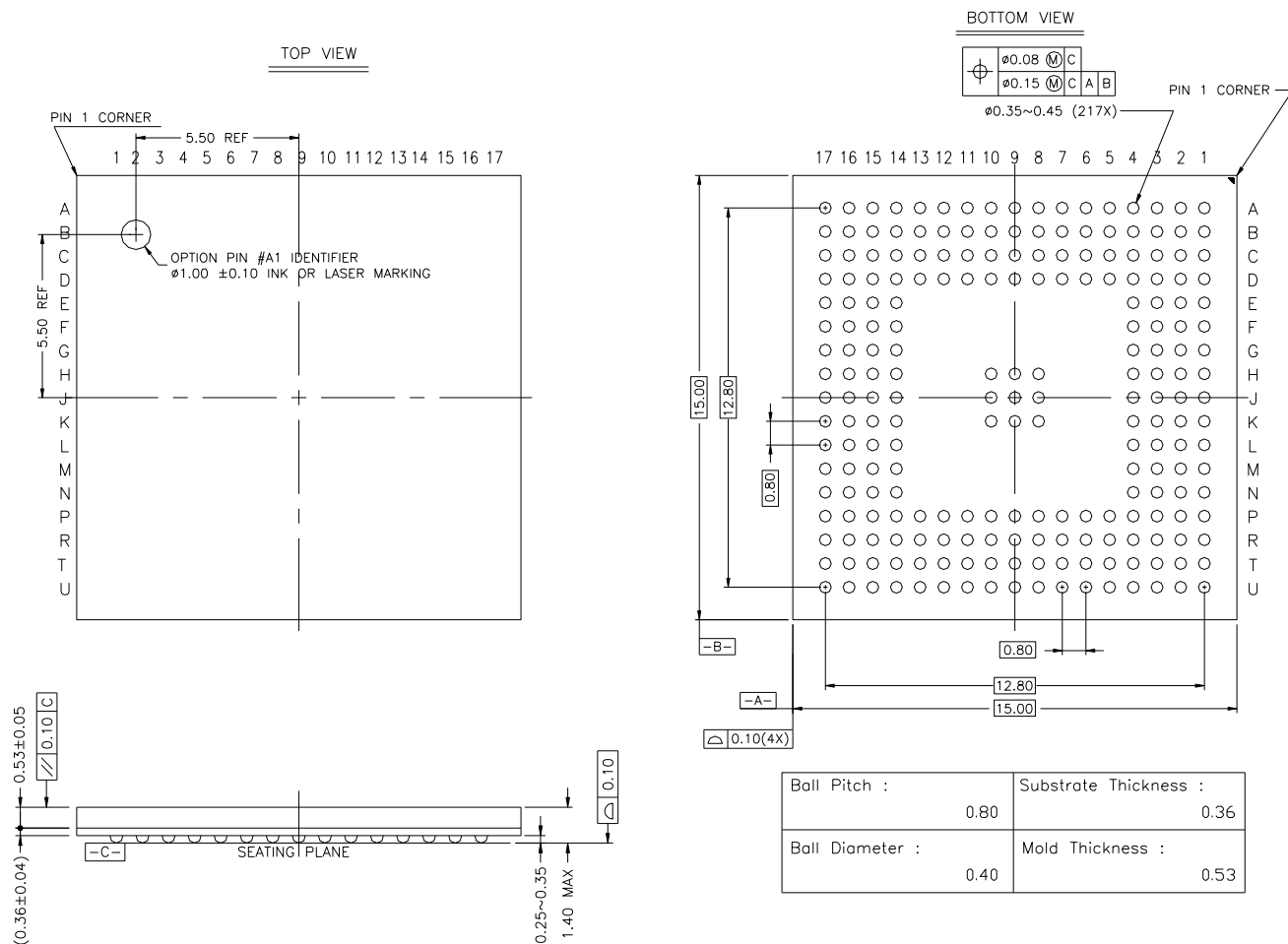

Table 39-1. Soldering Information (Substrate Level)

| | |
|---------------------|----------------|
| Ball Land | 0.43 mm ± 0.05 |
| Solder Mask Opening | 0.30 mm ± 0.05 |

Table 39-2. Device and 217-ball LFBGA Package Maximum Weight

| | |
|-----|----|
| 450 | mg |
|-----|----|

Table 39-3. 217-ball LFBGA Package Characteristics

| | |
|----------------------------|---|
| Moisture Sensitivity Level | 3 |
|----------------------------|---|

Table 39-4. Package Reference

| | |
|-------------------------|--------|
| JEDEC Drawing Reference | MO-205 |
| J-STD-609 Category | e1 |

39.2 Soldering Profile

Table 39-5 gives the recommended soldering profile from J-STD-20.

Table 39-5. Soldering Profile

| Profile Feature | Green Package |
|--|---------------------|
| Average Ramp-up Rate (217°C to Peak) | 3°C/sec. max. |
| Preheat Temperature 175°C ±25°C | 180 sec. max. |
| Temperature Maintained Above 217°C | 60 sec. to 150 sec. |
| Time within 5°C of Actual Peak Temperature | 20 sec. to 40 sec. |
| Peak Temperature Range | 260 +0 °C |
| Ramp-down Rate | 6°C/sec. max. |
| Time 25°C to Peak Temperature | 8 min. max. |

Note: It is recommended to apply a soldering temperature higher than 250°C.

A maximum of three reflow passes is allowed per component.

40. Marking

All devices are marked with the Atmel logo and the ordering code.

Additional marking is as follows:

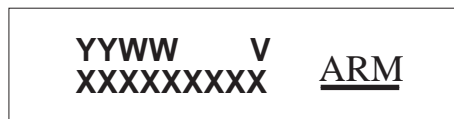

where

- “YY”: manufactory year
- “WW”: manufactory week
- “V”: revision
- “XXXXXXXXXX”: lot number

41. Ordering Information

Table 41-1. SAM9261 Ordering Information

| Ordering Code | Marketing Revision Level (MRL) | Package | Carrier Type | Operating Temperature Range |
|---------------------|--------------------------------|---------|---------------|-----------------------------|
| AT91SAM9261B-CU | B | BGA217 | Tray | Industrial -40°C to 85°C |
| AT91SAM9261B-CU-999 | B | BGA217 | Tape and Reel | Industrial -40°C to 85°C |

42. Errata

42.1 SAM9261 Errata - Revision A Parts

Refer to [Section 40. "Marking" on page 698.](#)

42.1.1 Main Oscillator

42.1.1.1 Main Oscillator: Spurious Malfunction of Main Oscillator

The main oscillator can exhibit spurious malfunction as exhibited by the duty-cycle not performing according to specification, missing main clock periods, or in the worst case, no main clock at all. The behavior does not alter over time. A device fully tested over the operating range (including power supply and temperature) in an application without exhibiting any malfunction will continue to function according to specifications.

Problem Fix/Workaround

Placing a series resistor of 470 Ω between XOUT and the crystal will fix the issue.

The additional series resistor will not alter the device specification as documented in the datasheet, including the startup time and power consumption.

42.1.2 Battery Backup

42.1.2.1 Backup Overconsumption during AHB Masters activity

Conditions:

During AHB Masters activity (LCD DMA, USB Host DMA, etc.) the backup current can rise up to 12 μA @ 25°C.

Problem Fix/Workaround

[Figure 42-1](#) shows how to feed the backup part of the chip from the battery only when the main power supply is off. In active mode, the clocks of unused peripherals should be disabled through the Power Management Controller to save power.

Figure 42-1. Schematic

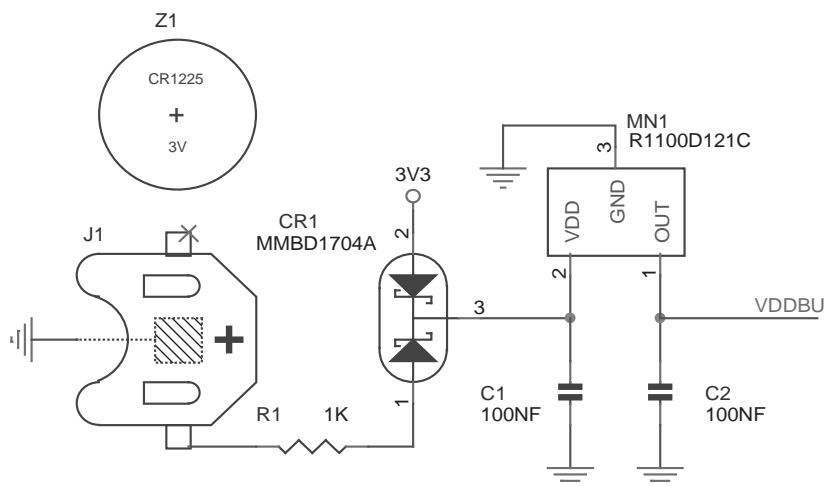

42.1.3 Boot ROM

42.1.3.1 Boot ROM: Only DataFlash Boot Is Functional

Boot from all other NVM is not functional in this revision.

Problem Fix/Workaround

None.

42.1.3.2 Boot ROM: Watchdog Disable

When SAM9261 boots on internal ROM (BMS =1) the watchdog timer is disabled by software. Because the watchdog mode register is a “write once”, the system, designed to boot on an SPI DataFlash, cannot reuse the watchdog functionality.

Problem Fix/Workaround

If the watchdog feature is mandatory for the application, the system must boot on external memory connected on CS0 (BMS = 0).

42.1.3.3 Boot ROM: Temperature Range

The temperature range for the Boot ROM use is 0°C / 70°C.

Starting up the device outside this temperature range can lead to unpredictable behavior. If the SAM9261-based system may have to start up at temperatures below 0°C and above 70°C, it is recommended to boot out of an external memory connected on NCS0.

Problem Fix/Workaround

None.

42.1.3.4 Boot ROM: UDP Pad Pull-up Enable

When SAM9261 boots on internal ROM (BMS = 1), the UDP pad pull-up is enabled by software. This can lead to an enumeration error.

Problem Fix/Workaround

Disable UDP pad pull-up at the beginning of the boot program (ex: at91bootstrap).

42.1.4 Bus Matrix

42.1.4.1 Bus Matrix: Problem with locked transfers261

Locked transfers are not correctly handled by the Bus Matrix and can lead to a system freeze up. This does not concern ARM locked transfers.

Problem Fix/Workaround

Avoid other Bus Matrix masters locked transfers.

42.1.5 LCD

42.1.5.1 LCD: Screen shifting after a reset

When a FIFO underflow occurs, a reset of the LCD DMA and FIFO pointers is necessary.

If only LCD DMA pointers are reset (FIFO pointers not reset), the displayed image is shifted.

Problem Fix/Workaround

Apply the following sequence to correctly reset LCD DMA and FIFO pointers:

- LCD power off
- DMA disable
- Wait for DMABUSY
- DMA reset
- LCD power on
- DMA enable.

Powering LCD off, then powering LCD on, resets the FIFO pointers.

Disabling DMA, then enabling DMA, resets the DMA pointers.

42.1.5.2 LCD: Periodic bad pixels

LCD periodic bad pixels is due to mis-aligned DMA base address in frame buffer. LCD DMA performs bursts to read memory. The LCD DMA bursts must not cross the 1-Kbyte AMBA boundary.

Problem Fix/Workaround

The LCD DMA burst size in 32-bit words is programmed by BRSTLN field in DMAFRMCFG register.

The LCD DMA Base Address is programmed in DMABADDR1 register.

The LCD DMA Base Address must be programmed with a value aligned onto LCD DMA burst size, e.g.:

BRSTLN = 15

For a 16-word burst, the LCD DMA Base Address must start on a 16-word offset: 0x0, 0x40, 0x80 or 0xc0.

BRSTLN = 3

For a 4-word burst, the LCD DMA Base Address offset must start on a 4-word offset: 0x0, 0x10, ..., 0xf0.

42.1.5.3 LCD: 24-bit Packed Mode

LCD DMA Base Address and LCD DMA burst size must be selected with care in 24-bit packed mode. A 32-bit word contains some bits of a pixel and some bits of the following. If LCD DMA Base Address is not aligned with a pixel start, the colors will be modified.

Respect "LCD periodic bad pixels" erratum constrains lead to select the LCD DMA Base Address regarding the LCD DMA burst size.

Problem Fix/Workaround

LCD DMA Base Address is to be set on a pixel start, every three 32-bit word.

The offset of the LCD DMA Base Address must be a multiple of 0x30 plus 0x0, 0xc, 0x18 or 0x24. (0x0, 0xc, 0x18, 0x24, 0x30, 0x3c, 0x48, 0x54, 0x60, 0x6c, 0x78, 0x84, 0x90, 0x9c, 0xa8, 0xb4, 0xc0...)

e.g. regarding the bursts size:

- 1) BRSTLN = 3 implies the following LCD DMA Base Address offsets: 0x0, 0x30, 0x60, ...
- 2) BRSTLN = 15 implies the following LCD DMA Base Address offsets: 0x0 and 0xc0 only.

42.1.6 MCI

42.1.6.1 MCI: Busy signal of R1b responses is not taken in account

The busy status of the card during the response (R1b) is ignored for the commands CMD7, CMD28, CMD29, CMD38, CMD42, CMD56. Additionally, for commands CMD42 and CMD56 a conflict can occur on data line 0 if the MCI sends data to the card while the card is still busy.

The behavior is correct for CMD12 command (STOP_TRANSFER).

Problem Fix/Workaround

None

42.1.6.2 MCI: Data Timeout Error Flag

As the data timeout error flag cannot rise, the MCI is stalled indefinitely waiting for the data start bit.

Problem Fix/Workaround

A STOP command must be sent with a software timeout.

42.1.6.3 MCI: STREAM command not supported

The STREAM READ/WRITE commands are not supported by the MCI.

Problem Fix/Workaround

None.

42.1.6.4 MCI: STOP during a WRITE_MULTIPLE_BLOCK command

The WRITE_MULTIPLE_BLOCK with a transfer size (PDC) not a multiple of the block length is not stopped by the STOP command.

Problem Fix/Workaround

Choose an appropriate size for the block length.

42.1.7 NTRST

42.1.7.1 NTRST: Device does not boot correctly due to powerup sequencing issue

The NTRST signal is powered by VDDIOP power supply (3.3V) and the ARM processor is powered by VDDCORE power supply (1.2V).

During the powerup sequence, if VDDIOP power supply is not established whereas the VDDCORE Power On Reset output is released, the NTRST signal is not correctly asserted. This leads to a bad reset of the Embedded Trace Macrocell (ETM9). The ARM processor then enters debug state and the device does not boot correctly.

Problem Fix/Workaround

1. Connect NTRST pin to NRST pin to ensure that a correct powering sequence takes place in all cases.
2. Connect NTRST to GND if no debug capabilities are required.

42.1.8 Reset Controller (RSTC)

42.1.8.1 RSTC: Reset During SDRAM Accesses

When a user reset, watchdog reset, or software reset occurs during SDRAM read access, the SDRAM clock is turned off while data are ready to be read on the data bus. The SDRAM maintains the data until the clock restarts.

If the user reset, watchdog reset, or software reset is programmed to assert a general reset, the data maintained by the SDRAM leads to a data bus conflict and adversely affects the boot memories connected on the EBI:

- NAND Flash boot functionality, if the system boots out of internal ROM.
- NOR Flash boot, if the system boots on an external memory connected on the EBI CS0.

Problem Fix/Workaround

1. Avoid user reset, watchdog reset, or software reset to generate a system reset.
2. Trap the user reset, watchdog reset, or software reset with an interrupt.

In the interrupt routine, power down the SDRAM properly and perform Peripheral and Processor Reset with software in assembler.

Example with libV3.

- The main code:

```
//user reset interrupt setting
// Configure AIC controller to handle System peripheral interrupts
AT91F_AIC_ConfigureIt (
    AT91C_BASE_AIC,                // AIC base address
    AT91C_ID_SYS,                  // System peripheral ID
    AT91C_AIC_PRIOR_HIGHEST,      // Max priority
    AT91C_AIC_SRCTYPE_INT_EDGE_TRIGGERED, // Level sensitive
    sysc_handler );

// Enable SYSC interrupt in AIC
AT91F_AIC_EnableIt(AT91C_BASE_AIC, AT91C_ID_SYS);

*AT91C_RSTC_RMR = (0xA5<<24) | (0x4<<8) | AT91C_RSTC_URSTIEN;
```

- The C SYS handler:

```

extern void soft_user_reset(void);

void sysc_handler(void){
//check if interrupt comes from RSTC
  if( (*AT91C_RSTC_RSR & AT91C_RSTC_URSTS ) == AT91C_RSTC_URSTS){
    soft_user_reset();
    //never reached
    while(1);

  }
}

```

- Assembly code is mandatory for the following sequence as we need to pipeline ARM instructions. The assembler routine:

```

AREA          TEST, CODE
              INCLUDE      AT91SAM9xxx.inc
              EXPORT soft_user_reset

soft_user_reset
;disable IRQs
  MRS r0, CPSR
  ORR r0, r0, #0x80
  MSR CPSR_c, r0

;change refresh rate to block all data accesses
  LDR r0, =AT91C_SDRAMC_TR
  LDR r1, =1
  STR r1, [r0]

;prepare power down command
  LDR r0, =AT91C_SDRAMC_LPR
  LDR r1, =2

;prepare proc_reset and periph_reset
  LDR r2, =AT91C_RSTC_RCR
  LDR r3, =0xA5000005

;perform power down command
  STR r1, [r0]
;perform proc_reset and periph_reset (in the ARM pipeline)
  STR r3, [r2]

  END

```

42.1.9 SDRAM Controller

42.1.9.1 SDRAM: SDCLK Clock active after reset

After a reset the SDRAM clock is always active leading in over consumption in the pad.

Problem Fix/Workaround

The following sequence allows to stop the SDRAM clock.

1. Set the bit LPCB to 01 (Self-refresh) in the SDRAMC Low Power Register.
2. Write 0 in the SDRAMC Mode Register and perform a dummy write in sdram to complete.

42.1.9.2 SDRAM: JEDEC Standard Compatibility

In the current configuration, SDCKE rises at the same time as SDCK, while exiting self-refresh mode. To be fully compliant with the JEDEC standard, SDCK must be stable before the rising edge of SDCKE. This is not the case in this product.

Problem Fix/Workaround

Use a fully JEDEC compliant SDRAM module.

42.1.9.3 SDRAM: Mobile SDRAM Device Initialization Constraint

Using Mobile SDRAM devices that need to have their DQMx level HIGH during the Mobile SDRAM device initialization, may lead to data bus contention. Therefore, external memories on the same EBI must not be accessed.

This does not apply to Mobile SDRAM devices whose DQMx level is “don't care” during this phase.

Problem Fix/Workaround

Mobile SDRAM initialization must be performed in internal SRAM.

42.1.10 Serial Peripheral Interface (SPI)

42.1.10.1 SPI: Pulse Generation on SPCK

In Master Mode, there is an additional pulse generated on SPCK when the SPI is configured as follows:

- The Baudrate is odd and different from 1.
- The Polarity is set to 1.
- The Phase is set to 0.

Problem Fix/Workaround

Do not use this configuration.

42.1.10.2 SPI: Bad PDC behavior when CSAAT = 1 and SCBR = 1

If the SPI2 is programmed with SPI_CSRx.CSAAT = 1, SPI_CSRx.SCBR (baud rate) = 1 and two transfers are performed consecutively on the same slave with an IDLE state between them, the second data is sent twice.

Problem Fix/Workaround

None. Do not use the combination CSAAT = 1 and SCBR = 1.

42.1.10.3 SPI: LASTXFER (Last Transfer) Behavior

In FIXED Mode, with CSAAT bit set, and in “PDC mode” the Chip Select can rise depending on the data written in the SPI_TDR when the TX_EMPTY flag is set. For example, if the PDC writes a ‘1’ in bit 24 (LASTXFER bit) of the SPI_TDR, the Chip Select rises as soon as the TXEMPTY flag is set.

Problem Fix/Workaround

Use the CS in PIO mode when “PDC mode” is required and CS has to be maintained between transfers.

42.1.10.4 SPI: Chip Select and fixed mode

In FIXED Mode, if a transfer is performed through a PDC on a Chip Select different from the Chip Select 0, the output `spi_size` sampled by the PDC will depend on the field `SPI_CSR0.BITS`, whatever the selected Chip Select is. For example if `SPI_CSR0` is configured for a 10-bit transfer whereas the `SPI_CSR1` is configured for an 8-bit transfer, when a transfer is performed in Fixed mode through the PDC on Chip Select 1, the transfer is considered as a halfword transfer.

Problem Fix/Workaround

If a PDC transfer has to be performed in 8 bits, on a Chip select `y` (`y` different from 0), the field `SPI_CSR0.BITS` must be configured in 8 bits in the same way as the field `BITS` of the `CSRy` Register.

42.1.10.5 SPI: Baud rate set to 1

When `SPI_CSRx.SCBR` (baud rate) = 1 (i.e., when serial clock frequency equals the system clock frequency), and when the field `BITS` (number of bits to be transmitted) equals an ODD value (in this case 9, 11, 13 or 15), an additional pulse is generated on output `SPCK`. No problem occurs if `BITS` field equals 8, 10, 12, 14 or 16 and `SCBR` (baud rate) = 1.

Problem Fix/Workaround

None.

42.1.10.6 SPI: Software Reset

If the Software reset command is performed at the same clock cycle as an event for `TXRDY` occurs, there is no reset.

Problem Fix/Workaround

Perform another software reset.

42.1.10.7 SPI: Software Reset Must be Written Twice

If a software reset (`SWRST` in the SPI Control Register) is performed, the SPI may not work properly (the clock is enabled before the chip select).

Problem Fix/Workaround

The field `SPI_CR.SWRST` needs to be written twice to be correctly set.

42.1.10.8 SPI: Bad Serial Clock Generation on 2nd Chip Select

Bad Serial clock generation on the 2nd chip select when `SSPI_CSRx.SCBR` = 1, `SPI_CSRx.CPOL` = 1 and `SPI_CSRx.NCPHA` = 0.

This occurs using SPI with the following conditions:

- Master Mode
- `CPOL` = 1 and `NCPHA` = 0
- Multiple chip selects are used with one transfer with `SCBR` (baud rate) = 1 (i.e., when serial clock frequency equals the system clock frequency) and the other transfers set with `SCBR` are not equal to 1.
- Transmitting with the slowest chip select and then with the fastest one, then an additional pulse is generated on output `SPCK` during the second transfer.

Problem Fix/Workaround

Do not use a multiple Chip Select configuration where at least one `SPI_CSRx` is configured with `SCBR` = 1 and the others differ from 1 if `NCPHA` = 0 and `CPOL` = 1.

If all chip selects are configured with `SCBR` (baud rate) = 1, the issue does not appear.

42.1.11 Serial Synchronous Controller (SSC)

42.1.11.1 SSC: Transmitter Limitations in Slave Mode

If TK is programmed as input and TF is programmed as output and requested to be set to low/high during data emission, the Frame Synchro is generated one bit clock period after the data start, one data bit is lost. This problem does not exist when generating periodic synchro.

Problem Fix/Workaround

The data need to be delayed for one bit clock period with an external assembly.

In the following schematic, TD, TK and NRST are SAM9261 signals, TXD is the delayed data to connect to the device.

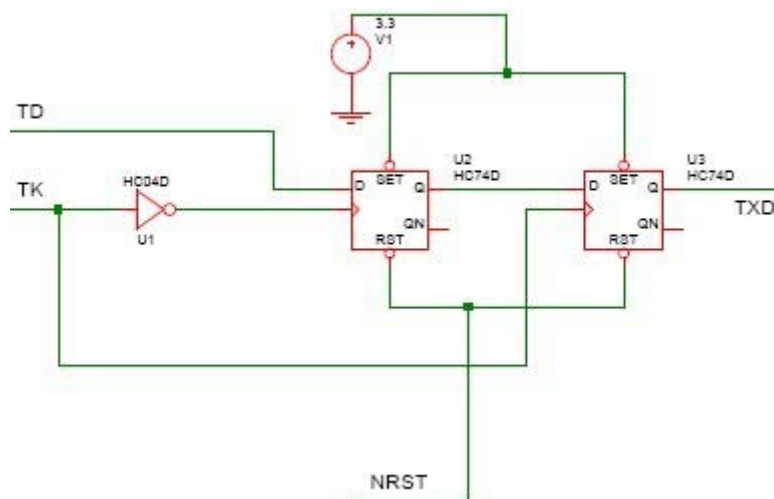

42.1.11.2 SSC: Periodic Transmission Limitations in Master Mode

If the Least Significant Bit is sent first (MSBF = 0) the first TAG during the frame synchro is not sent.

Problem Fix/Workaround

None.

42.1.11.3 SSC: Last RK Clock Cycle when RK Outputs a Clock During Data Transfer

When the SSC receiver is used with the following conditions:

- the internal clock divider is used (CKS = 0 and DIV different from 0)
- RK pin set as output and provides the clock during data transfer (CKO = 2)
- data sampled on RK falling edge (CKI = 0)

At the end of the data, the RK pin is set in high impedance which might be seen as an unexpected clock cycle.

Problem Fix/Workaround

Enable the pull-up on RK pin.

42.1.11.4 SSC: First RK Clock Cycle when RK Outputs a Clock During Data Transfer

When the SSC receiver is used with the following conditions:

- RX clock is divided clock (CKS = 0 and DIV different from 0)
- RK pin set as output and provides the clock during data transfer (CKO = 2)
- data sampled on RK falling edge (CKI = 0)

The first clock cycle time generated by the RK pin is equal to $MCK/(2 \times (\text{value} + 1))$.

Problem Fix/Workaround

None.

42.1.12 Shutdown Controller (SHDWC)

42.1.12.1 SHDWC: Boundary Scan Mode Outputs the 32 kHz clock

In boundary scan mode, the SHDN pin outputs the 32 kHz clock.

Problem/Fix Workaround

There is only one way to disable the 32 kHz clock on the SHDN pin.

In boundary scan mode, connect TST and JTAGSEL pins to VDDBU and set the SHDN pin to low level.

42.1.12.2 SHDWC: Bad Behavior of Shutdown Pin

SHDN signal may be driven to Low level voltage during device power-on. If only VDDBU is powered during boot sequence (No VDDCORE), the SHDN signal may be driven to Low level voltage after a delay. This delay is linked to the startup time of the slow clock selected by OSCSEL signal. If the SHDN pin is connected to the Enable pin (EN) of the VDDCORE regulator, VDDCORE establishment does not occur and the system does not start.

Problem/Fix Workaround

1. VDDCORE must be established within the delay corresponding to the startup time of the slow clock selected by OSCSEL.
2. Add a glue logic to latch the rising edge of the SHDN signal. The reset of the latch output (EN_REG) can be connected to a PIO and used to enter the shutdown mode.

42.1.13 Static Memory Controller (SMC)

42.1.13.1 SMC: Chip Select Parameters Modification

The user must not change the configuration parameters of an SMC Chip Select (Setup, Pulse, Cycle, Mode) if accesses are performed on this CS during the modification.

For example, the modification of the Chip Select 0 (CS0) parameters, while fetching the code from a memory connected on this CS0, may lead to unpredictable behavior.

Problem Fix/Workaround

The code used to modify the parameters of an SMC Chip Select can be executed from the internal RAM or from a memory connected to another Chip Select

42.1.14 System Controller (SYSC)

42.1.14.1 SYSC: Possible event loss when reading RTT_SR

If an event (RTTINC or ALMS) occurs within the same slow clock cycle as when the RTT_SR is read, the corresponding bit might be cleared. This can lead to the loss of this event.

Problem Fix/Workaround

The software must handle an RTT event as interrupt and as the only source of the interrupt source level 1.

42.1.15 Two-wire Interface (TWI)

42.1.15.1 TWI: Clock Divider

The value of $CLDIV \times 2^{CKDIV}$ must be less than or equal to 8191, the value of $CHDIV \times 2^{CKDIV}$ must be less than or equal to 8191.

Problem Fix/Workaround

None.

42.1.15.2 TWI: Disabling Does not Operate Correctly

Any transfer in progress is immediately frozen if the Control Register (TWI_CR) is written with the bit MSDIS at 1. Furthermore, the status bits TXCOMP and TXRDY in the Status Register (TWI_SR) are not reset.

Problem Fix/Workaround

The user must wait for the end of transfer before disabling the TWI. In addition, the interrupts must be disabled before disabling the TWI.

42.1.15.3 TWI: NACK Status Bit Lost

During a master frame, if TWI_SR is read between the Non Acknowledge condition detection and the TXCOMP bit rising in the TWI_SR, the NACK bit is not set.

Problem Fix/Workaround

The user must wait for the TXCOMP status bit by interrupt and must not read the TWI_SR as long as transmission is not completed.

Note: TXCOMP and NACK fields are set simultaneously and the NACK field is reset after the read of the TWI_SR.

42.1.15.4 TWI: Possible Receive Holding Register Corruption

When loading the TWI_RHR, the transfer direction is ignored. The last data byte received in the TWI_RHR is corrupted at the end of the first subsequent transmit data byte. Neither RXRDY nor OVERRUN status bits are set if this occurs.

Problem Fix/Workaround

The user must be sure that received data is read before transmitting any new data.

42.1.15.5 TWI: Software reset

When a software reset is performed during a frame and when TWCK is low, it is impossible to initiate a new transfer in READ or WRITE mode.

Problem Fix/Workaround

None.

42.1.15.6 TWI: STOP not generated

If the sequence described as follows occurs:

1. WRITE 1 or more bytes at a given address.
2. Send a STOP.
3. Wait for TXCOMP flag.
4. READ (or WRITE) 1 or more bytes at the same address.

then STOP is not generated.

The line will show: DADR BYTE 1, ..., BYTE n, NO STOP generated, BYTE 1, ..., BYTE n.

Problem Fix/Workaround

Insert a delay of one TWI clock period before step 4 in the sequence above.

42.1.16 UDP

42.1.16.1 UDP: Bad data in the first IN data stage

All or part of the data of the first IN data Stage are not transmitted. It may then be a Zero Length Packet. The CRC is correct. So the HOST may only see that the size of the received data does not match the requested length. But even if performed again, the control transfer will probably fail.

Problem Fix/Workaround

These Control transfers are mainly used at device configuration. After clearing RXSETUP, the software needs to compute the setup transaction request before writing data into the FIFO if needed. This time is generally greater

than the minimum safe delay required above. If not, a software wait loop after RXSETUP clear may be added at minimum cost

42.1.17 UHP

42.1.17.1 UHP: Non-ISO IN transfers

Conditions:

Consider the following sequence:

1. The Host controller issues an IN token.
2. The Device provides the IN data in a short packet.
3. The Host controller writes the received data to the system memory.
4. The Host controller is now supposed to carry out two Write transactions (TD status write and TD retirement write) to the system memory in order to complete the status update.
5. The Host controller raises the request for the first write transaction. By the time the transaction is completed, a frame boundary is crossed.
6. After completing the first write transaction, the Host controller skips the second write transaction.

Consequence: When this defect manifests itself, the Host controller re-attempts the same IN token.

Problem Fix/Workaround

This problem can be avoided if the system guarantees that the status update can be completed within the same frame.

42.1.17.2 UHP: ISO OUT transfers

Conditions:

Consider the following sequence:

1. The Host controller sends an ISO OUT token after fetching 16 bytes of data from the system memory.
2. When the Host controller is sending the ISO OUT data, because of system latencies, remaining bytes of the packet are not available. This results in a buffer underrun condition.
3. While there is an underrun condition, if the Host controller is in the process of bit-stuffing, it causes the Host controller to hang.

Consequence: After the failure condition, the Host controller stops sending the SOF. This causes the connected device to go into suspend state.

Problem Fix/Workaround

This problem can be avoided if the system can guarantee that no buffer underrun occurs during the transfer.

42.1.17.3 UHP: Remote Wakeup event

Conditions:

When a Remote Wakeup event occurs on a downstream port, the OHCI Host controller begins sending resume signaling to the device. The Host controller is supposed to send this resume signaling for 20 ms. However, if the driver sets the HcControl.HCFS into USBOPERATIONAL state during the resume event, then the Host controller terminates sending the resume signal with an EOP to the device.

Consequence: If the Device does not recognize the resume (< 20 ms) event, then the Device will remain in suspend state.

Problem Fix/Workaround

Host stack can do a port resume after it sets the HcControl.HCFS to USBOPERATIONAL.

42.1.18 USART

42.1.18.1 USART: CTS signal in Hardware Handshake

When Hardware Handshaking is used and if CTS goes low near the end of the starting bit of the transmitter, a character is lost.

Problem Fix/Workaround

CTS must not go low during a time slot comprised between 2 Master Clock periods before the rising edge of the starting bit and 16 Master Clock periods after the rising edge of the starting bit.

42.1.18.2 USART: RTS unexpected behavior

1. Setting the receiver to hardware handshaking mode drops RTS line to low level even if the receiver is still turned off. USART needs to be completely configured and started before setting the receiver to hardware handshaking mode.
2. Disabling the receiver during a PDC transfer while RXBUFF flag is '0' has no effect on RTS. The only way to get the RTS line rising to high level is to reset both PDMA buffers by writing the value '0' in both counter registers.

Problem Fix/Workaround

None.

42.1.18.3 USART: TXD signal is Floating in Modem and Hardware Handshaking Mode

TXD signal should be pulled up in Modem and Hardware Handshaking mode.

Problem Fix/Workaround

TXD is multiplexed with a PIO which integrates a pull-up resistor. This internal pullup needs to be enabled.

42.1.18.4 USART: DCD is Active High Instead of Low

DCD signal is active at "High" level in USART block (Modem Mode).

DCD should be active at "Low" level.

Problem Fix/Workaround

Add an inverter.

42.2 SAM9261 Errata - Revision B Parts

Refer to [Section 40. "Marking" on page 698.](#)

42.2.1 Main Oscillator

42.2.1.1 Main Oscillator: Spurious Malfunction of Main Oscillator

The main oscillator can exhibit spurious malfunction as exhibited by the duty-cycle not performing according to specification, missing main clock periods, or in the worst case, no main clock at all. The behavior does not alter over time. A device fully tested over the operating range (including power supply and temperature) in an application without exhibiting any malfunction will continue to function according to specifications.

Problem Fix/Workaround

Placing a series resistor of 470 Ω between XOUT and the crystal will fix the issue.

The additional series resistor will not alter the device specification as documented in the datasheet, including the startup time and power consumption.

42.2.2 Battery Backup

42.2.2.1 Backup Overconsumption during AHB Masters activity

Conditions:

During AHB Masters activity (LCD DMA, USB Host DMA, etc.) the backup current can rise up to 12 μA @ 25°C.

Problem Fix/Workaround

[Figure 42-2](#) shows how to feed the backup part of the chip from the battery only when the main power supply is off. In active mode, the clocks of unused peripherals should be disabled through the Power Management Controller to save power.

Figure 42-2. Schematic

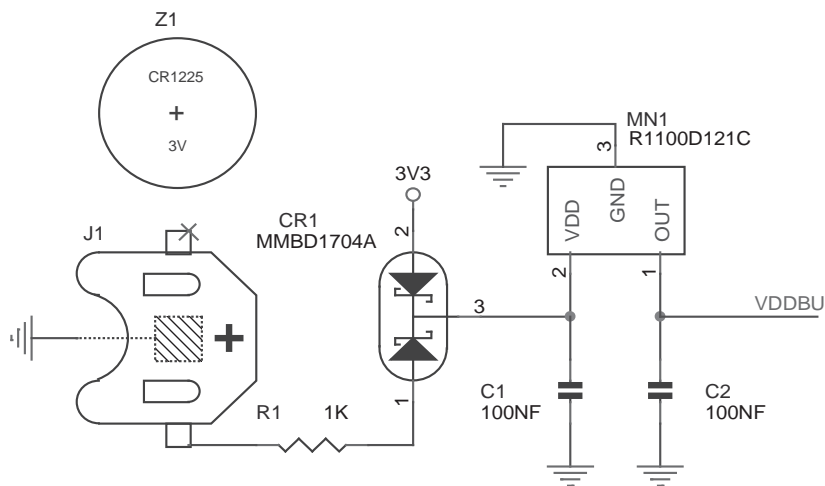

42.2.3 Boot ROM

42.2.3.1 Boot ROM: Temperature Range

The temperature range for the Boot ROM use is 0°C / 70°C.

Starting up the device outside this temperature range can lead to unpredictable behavior. If the SAM9261-based system may have to start up at temperatures below 0°C and above 70°C, it is recommended to boot out of an external memory connected on NCS0.

Problem Fix/Workaround

None.

42.2.3.2 Boot ROM: UDP Pad Pull-up Enable

When SAM9261 boots on internal ROM (BMS = 1), the UDP pad pull-up is enabled by software. This can lead to an enumeration error.

Problem Fix/Workaround

Disable UDP pad pull-up at the beginning of the boot program (ex: at91bootstrap).

42.2.3.3 Boot ROM: Code Size Limitation for DataFlash and Serial Flash Boot

The maximum downloadable code size, from DataFlash and Serial Flash, is limited to 64 Kbytes. That limitation does not affect other memories or existing AT91SAM9 products.

Problem Fix/Workaround

- A) Reduce first level bootloader code to 64 Kbytes to boot on a second level bootloader code if needed.
- B) If not possible, use another memory for booting purpose such as NAND Flash, serial EEPROM or a SDCard which do not have this limitation.

42.2.4 Bus Matrix

42.2.4.1 Bus Matrix: Problem with locked transfers261

Locked transfers are not correctly handled by the Bus Matrix and can lead to a system freeze up. This does not concern ARM locked transfers.

Problem Fix/Workaround

Avoid other Bus Matrix masters locked transfers.

42.2.5 LCD

42.2.5.1 LCD: Screen shifting after a reset

When a FIFO underflow occurs, a reset of the LCD DMA and FIFO pointers is necessary.

If only LCD DMA pointers are reset (FIFO pointers not reset), the displayed image is shifted.

Problem Fix/Workaround

Apply the following sequence to correctly reset LCD DMA and FIFO pointers:

- LCD power off
- DMA disable
- Wait for DMABUSY
- DMA reset
- LCD power on
- DMA enable.

Powering LCD off, then powering LCD on, resets the FIFO pointers.

Disabling DMA, then enabling DMA, resets the DMA pointers.

42.2.5.2 LCD: Periodic bad pixels

LCD periodic bad pixels is due to mis-aligned DMA base address in frame buffer. LCD DMA performs bursts to read memory. The LCD DMA bursts must not cross the 1-Kbyte AMBA boundary.

Problem Fix/Workaround

The LCD DMA burst size in 32-bit words is programmed by BRSTLN field in DMAFRMCFG register.

The LCD DMA Base Address is programmed in DMABADDR1 register.

The LCD DMA Base Address must be programmed with a value aligned onto LCD DMA burst size, e.g.:

BRSTLN = 15

For a 16-word burst, the LCD DMA Base Address must start on a 16-word offset: 0x0, 0x40, 0x80 or 0xc0.

BRSTLN = 3

For a 4-word burst, the LCD DMA Base Address offset must start on a 4-word offset: 0x0, 0x10, ..., 0xf0.

42.2.5.3 LCD: 24-bit Packed Mode

LCD DMA Base Address and LCD DMA burst size must be selected with care in 24-bit packed mode. A 32-bit word contains some bits of a pixel and some bits of the following. If LCD DMA Base Address is not aligned with a pixel start, the colors will be modified.

Respect "LCD periodic bad pixels" erratum constrains lead to select the LCD DMA Base Address regarding the LCD DMA burst size.

Problem Fix/Workaround

LCD DMA Base Address is to be set on a pixel start, every three 32-bit word.

The offset of the LCD DMA Base Address must be a multiple of 0x30 plus 0x0, 0xc, 0x18 or 0x24. (0x0, 0xc, 0x18, 0x24, 0x30, 0x3c, 0x48, 0x54, 0x60, 0x6c, 0x78, 0x84, 0x90, 0x9c, 0xa8, 0xb4, 0xc0 ...)

e.g. regarding the bursts size:

1. BRSTLN = 3 implies the following LCD DMA Base Address offsets: 0x0, 0x30, 0x60, ...
2. BRSTLN = 15 implies the following LCD DMA Base Address offsets: 0x0 and 0xc0 only.

42.2.6 MCI

42.2.6.1 MCI: Busy signal of R1b responses is not taken in account

The busy status of the card during the response (R1b) is ignored for the commands CMD7, CMD28, CMD29, CMD38, CMD42, CMD56. Additionally, for commands CMD42 and CMD56 a conflict can occur on data line 0 if the MCI sends data to the card while the card is still busy.

The behavior is correct for CMD12 command (STOP_TRANSFER).

Problem Fix/Workaround

None

42.2.6.2 MCI: Data Timeout Error Flag

As the data timeout error flag cannot rise, the MCI is stalled indefinitely waiting for the data start bit.

Problem Fix/Workaround

A STOP command must be sent with a software timeout.

42.2.6.3 MCI: STREAM command not supported

The STREAM READ/WRITE commands are not supported by the MCI.

Problem Fix/Workaround

None.

42.2.6.4 MCI: STOP during a WRITE_MULTIPLE_BLOCK command

The WRITE_MULTIPLE_BLOCK with a transfer size (PDC) not a multiple of the block length is not stopped by the STOP command.

Problem Fix/Workaround

Choose an appropriate size for the block length.

42.2.7 NTRST

42.2.7.1 NTRST: Device does not boot correctly due to powerup sequencing issue

The NTRST signal is powered by VDDIOP power supply (3.3V) and the ARM processor is powered by VDDCORE power supply (1.2V).

During the powerup sequence, if VDDIOP power supply is not established whereas the VDDCORE Power On Reset output is released, the NTRST signal is not correctly asserted. This leads to a bad reset of the Embedded Trace Macrocell (ETM9). The ARM processor then enters debug state and the device does not boot correctly.

Problem Fix/Workaround

1. Connect NTRST pin to NRST pin to ensure that a correct powering sequence takes place in all cases.
2. Connect NTRST to GND if no debug capabilities are required.

42.2.8 Reset Controller (RSTC)

42.2.8.1 RSTC: Reset During SDRAM Accesses

When a user reset, watchdog reset, or software reset occurs during SDRAM read access, the SDRAM clock is turned off while data are ready to be read on the data bus. The SDRAM maintains the data until the clock restarts.

If the user reset, watchdog reset, or software reset is programmed to assert a general reset, the data maintained by the SDRAM leads to a data bus conflict and adversely affects the boot memories connected on the EBI:

- NAND Flash boot functionality, if the system boots out of internal ROM.
- NOR Flash boot, if the system boots on an external memory connected on the EBI CS0.

Problem Fix/Workaround

1. Avoid user reset, watchdog reset, or software reset to generate a system reset.
2. Trap the user reset, watchdog reset, or software reset with an interrupt.

In the interrupt routine, power down the SDRAM properly and perform Peripheral and Processor Reset with software in assembler.

Example with libV3.

- The main code:

```
//user reset interrupt setting
// Configure AIC controller to handle SSC interrupts
AT91F_AIC_ConfigureIt (
    AT91C_BASE_AIC,                // AIC base address
    AT91C_ID_SYS,                 // System peripheral ID
    AT91C_AIC_PRIOR_HIGHEST,      // Max priority
    AT91C_AIC_SRCTYPE_INT_EDGE_TRIGGERED, // Level sensitive
    sysc_handler );

// Enable SYSC interrupt in AIC
AT91F_AIC_EnableIt(AT91C_BASE_AIC, AT91C_ID_SYS);

*AT91C_RSTC_RMR = (0xA5<<24) | (0x4<<8) | AT91C_RSTC_URSTIEN;
```

- The C SYS handler:

```
extern void soft_user_reset(void);

void sysc_handler(void){
//check if interrupt comes from RSTC
if( (*AT91C_RSTC_RSR & AT91C_RSTC_URSTS ) == AT91C_RSTC_URSTS){
    soft_user_reset();
    //never reached
    while(1);
}
}
```

- The assembler routine:

```

AREA          TEST, CODE
INCLUDE      AT91SAM9xxx.inc
EXPORT soft_user_reset

soft_user_reset
;disable IRQs
    MRS r0, CPSR
    ORR r0, r0, #0x80
    MSR CPSR_c, r0

;change refresh rate to block all data accesses
    LDR r0, =AT91C_SDRAMC_TR
    LDR r1, =1
    STR r1, [r0]

;prepare power down command
    LDR r0, =AT91C_SDRAMC_LPR
    LDR r1, =2

;prepare proc_reset and periph_reset
    LDR r2, =AT91C_RSTC_RCR
    LDR r3, =0xA5000005

;perform power down command
    STR r1, [r0]
;perform proc_reset and periph_reset (in the ARM pipeline)
    STR r3, [r2]

    END

```

42.2.9 SDRAM Controller

42.2.9.1 SDRAM: SDCLK Clock active after reset

After a reset the SDRAM clock is always active leading in over consumption in the pad.

Problem Fix/Workaround

The following sequence allows to stop the SDRAM clock.

1. Set the bit LPCB to 01 (Self-refresh) in the SDRAMC Low Power Register.
2. Write 0 in the SDRAMC Mode Register and perform a dummy write in sdram to complete.

42.2.9.2 SDRAM: JEDEC Standard Compatibility

In the current configuration, SDCKE rises at the same time as SDCK, while exiting self-refresh mode. To be fully compliant with the JEDEC standard, SDCK must be stable before the rising edge of SDCKE. This is not the case in this product.

Problem Fix/Workaround

Use a fully JEDEC compliant SDRAM module.

42.2.9.3 SDRAM: Mobile SDRAM Device Initialization Constraint

Using Mobile SDRAM devices that need to have their DQMx level HIGH during the Mobile SDRAM device initialization, may lead to data bus contention. Therefore, external memories on the same EBI must not be accessed.

This does not apply to Mobile SDRAM devices whose DQMx level is “don’t care” during this phase.

Problem Fix/Workaround

Mobile SDRAM initialization must be performed in internal SRAM.

42.2.10 Serial Peripheral Interface (SPI)

42.2.10.1 SPI: Pulse Generation on SPCK

In Master Mode, there is an additional pulse generated on SPCK when the SPI is configured as follows:

- The Baudrate is odd and different from 1.
- The Polarity is set to 1.
- The Phase is set to 0.

Problem Fix/Workaround

Do not use this configuration.

42.2.10.2 SPI: Bad PDC behavior when CSAAT = 1 and SCBR = 1

If the SPI2 is programmed with `SPI_CSRx.CSAAT = 1`, `SPI_CSRx.SCBR` (baud rate) = 1 and two transfers are performed consecutively on the same slave with an IDLE state between them, the second data is sent twice.

Problem Fix/Workaround

None. Do not use the combination `CSAAT = 1` and `SCBR = 1`.

42.2.10.3 SPI: LASTXFER (Last Transfer) Behavior

In FIXED Mode, with CSAAT bit set, and in “PDC mode” the Chip Select can rise depending on the data written in the SPI_TDR when the TX_EMPTY flag is set. For example, if the PDC writes a ‘1’ in bit 24 (LASTXFER bit) of the SPI_TDR, the Chip Select rises as soon as the TXEMPTY flag is set.

Problem Fix/Workaround

Use the CS in PIO mode when “PDC mode” is required and CS has to be maintained between transfers.

42.2.10.4 SPI: Chip Select and fixed mode

In FIXED Mode, if a transfer is performed through a PDC on a Chip Select different from the Chip Select 0, the output `spi_size` sampled by the PDC will depend on the field `SPI_CSR0.BITS`, whatever the selected Chip select is. For example if `SPI_CSR0` is configured for a 10-bit transfer whereas the `SPI_CSR1` is configured for an 8-bit transfer, when a transfer is performed in Fixed mode through the PDC on Chip Select 1, the transfer is considered as a halfword transfer.

Problem Fix/Workaround

If a PDC transfer has to be performed in 8 bits, on a Chip select `y` (`y` different from 0), the field `SPI_CSR0.BITS` must be configured in 8 bits in the same way as the field `BITS` of the `CSRy` Register.

42.2.10.5 SPI: Baud rate set to 1

When `SPI_CSRx.SCBR` (baud rate) = 1 (i.e., when serial clock frequency equals the system clock frequency), and when the field `BITS` (number of bits to be transmitted) equals an ODD value (in this case 9, 11, 13 or 15), an additional pulse is generated on output SPCK. No problem occurs if `BITS` field equals 8, 10, 12, 14 or 16 and `SCBR` (baud rate) = 1.

Problem Fix/Workaround

None.

42.2.10.6 SPI: Software Reset

If the Software reset command is performed at the same clock cycle as an event for TXRDY occurs, there is no reset.

Problem Fix/Workaround

Perform another software reset.

42.2.10.7 SPI: Software Reset Must be Written Twice

If a software reset (SWRST in the SPI Control Register) is performed, the SPI may not work properly (the clock is enabled before the chip select).

Problem Fix/Workaround

The field SPI_CR.SWRST needs to be written twice to be correctly set.

42.2.10.8 SPI: Bad Serial Clock Generation on 2nd Chip Select

Bad Serial clock generation on the 2nd chip select when SPI_CSRx.SCBR = 1, SPI_CSRx.CPOL = 1 and SPI_CSRx.NCPHA = 0.

This occurs using SPI with the following conditions:

- Master Mode
- CPOL = 1 and NCPHA = 0
- Multiple chip selects are used with one transfer with SCBR (baud rate) = 1 (i.e., when serial clock frequency equals the system clock frequency) and the other transfers set with SCBR are not equal to 1.
- Transmitting with the slowest chip select and then with the fastest one, then an additional pulse is generated on output SPCK during the second transfer.

Problem Fix/Workaround

Do not use a multiple Chip Select configuration where at least one SPI_CSRx is configured with SCBR = 1 and the others differ from 1 if NCPHA = 0 and CPOL = 1.

If all chip selects are configured with SCBR (baud rate) = 1, the issue does not appear.

42.2.11 Serial Synchronous Controller (SSC)

42.2.11.1 SSC: Transmitter Limitations in Slave Mode

If TK is programmed as input and TF is programmed as output and requested to be set to low/high during data emission, the Frame Synchro is generated one bit clock period after the data start, one data bit is lost. This problem does not exist when generating periodic synchro.

Problem Fix/Workaround

The data need to be delayed for one bit clock period with an external assembly.

In the following schematic, TD, TK and NRST are SAM9261 signals, TXD is the delayed data to connect to the device.

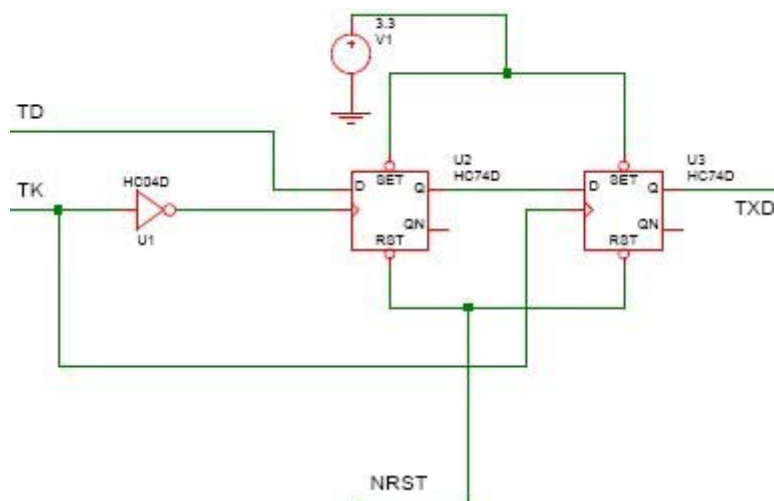

42.2.11.2 SSC: Periodic Transmission Limitations in Master Mode

If the Least Significant Bit is sent first (MSBF = 0) the first TAG during the frame synchro is not sent.

Problem Fix/Workaround

None.

42.2.11.3 SSC: Last RK Clock Cycle when RK Outputs a Clock During Data Transfer

When the SSC receiver is used with the following conditions:

- the internal clock divider is used (CKS = 0 and DIV different from 0)
- RK pin set as output and provides the clock during data transfer (CKO = 2)
- data sampled on RK falling edge (CKI = 0)

At the end of the data, the RK pin is set in high impedance which might be seen as an unexpected clock cycle.

Problem Fix/Workaround

Enable the pull-up on RK pin.

42.2.11.4 SSC: First RK Clock Cycle when RK Outputs a Clock During Data Transfer

When the SSC receiver is used with the following conditions:

- RX clock is divided clock (CKS = 0 and DIV different from 0)
- RK pin set as output and provides the clock during data transfer (CKO = 2)
- data sampled on RK falling edge (CKI = 0)

The first clock cycle time generated by the RK pin is equal to $MCK/(2 \times (\text{value} + 1))$.

Problem Fix/Workaround

None.

42.2.12 Shutdown Controller (SHDWC)

42.2.12.1 SHDWC: Boundary Scan Mode Outputs the 32 kHz clock

In boundary scan mode, the SHDN pin outputs the 32 kHz clock.

Problem/Fix Workaround

There is only one way to disable the 32 kHz clock on the SHDN pin.

In boundary scan mode, connect TST and JTAGSEL pins to VDDBU and set the SHDN pin to low level.

42.2.12.2 SHDWC: Bad Behavior of Shutdown Pin

SHDN signal may be driven to Low level voltage during device power-on. If only VDDBU is powered during boot sequence (No VDDCORE), the SHDN signal may be driven to Low level voltage after a delay. This delay is linked to the startup time of the slow clock selected by OSCSEL signal. If the SHDN pin is connected to the Enable pin (EN) of the VDDCORE regulator, VDDCORE establishment does not occur and the system does not start.

Problem/Fix Workaround

1. VDDCORE must be established within the delay corresponding to the startup time of the slow clock selected by OSCSEL.

Add a glue logic to latch the rising edge of the SHDN signal. The reset of the latch output (EN_REG) can be connected to a PIO and used to enter the shutdown mode.

42.2.13 Static Memory Controller (SMC)

42.2.13.1 SMC: Chip Select Parameters Modification

The user must not change the configuration parameters of an SMC Chip Select (Setup, Pulse, Cycle, Mode) if accesses are performed on this CS during the modification.

For example, the modification of the Chip Select 0 (CS0) parameters, while fetching the code from a memory connected on this CS0, may lead to unpredictable behavior.

Problem Fix/Workaround

The code used to modify the parameters of an SMC Chip Select can be executed from the internal RAM or from a memory connected to another Chip Select

42.2.14 System Controller (SYSC)

42.2.14.1 SYSC: Possible event loss when reading RTT_SR

If an event (RTTINC or ALMS) occurs within the same slow clock cycle as when the RTT_SR is read, the corresponding bit might be cleared. This can lead to the loss of this event.

Problem Fix/Workaround

The software must handle an RTT event as interrupt and as the only source of the interrupt source level 1.

42.2.15 Two-wire Interface (TWI)

42.2.15.1 TWI: Clock Divider

The value of $CLDIV \times 2^{CKDIV}$ must be less than or equal to 8191, the value of $CHDIV \times 2^{CKDIV}$ must be less than or equal to 8191.

Problem Fix/Workaround

None.

42.2.15.2 TWI: Disabling Does not Operate Correctly

Any transfer in progress is immediately frozen if the Control Register (TWI_CR) is written with the bit MSDIS at 1. Furthermore, the status bits TXCOMP and TXRDY in the Status Register (TWI_SR) are not reset.

Problem Fix/Workaround

The user must wait for the end of transfer before disabling the TWI. In addition, the interrupts must be disabled before disabling the TWI.

42.2.15.3 TWI: NACK Status Bit Lost

During a master frame, if TWI_SR is read between the Non Acknowledge condition detection and the TXCOMP bit rising in the TWI_SR, the NACK bit is not set.

Problem Fix/Workaround

The user must wait for the TXCOMP status bit by interrupt and must not read the TWI_SR as long as transmission is not completed.

Note: TXCOMP and NACK fields are set simultaneously and the NACK field is reset after the read of the TWI_SR.

42.2.15.4 TWI: Possible Receive Holding Register Corruption

When loading the TWI_RHR, the transfer direction is ignored. The last data byte received in the TWI_RHR is corrupted at the end of the first subsequent transmit data byte. Neither RXRDY nor OVERRUN status bits are set if this occurs.

Problem Fix/Workaround

The user must be sure that received data is read before transmitting any new data.

42.2.15.5 TWI: Software reset

When a software reset is performed during a frame and when TWCK is low, it is impossible to initiate a new transfer in READ or WRITE mode.

Problem Fix/Workaround

None.

42.2.15.6 TWI: STOP not generated

If the sequence described as follows occurs:

1. WRITE 1 or more bytes at a given address.
2. Send a STOP.
3. Wait for TXCOMP flag.
4. READ (or WRITE) 1 or more bytes at the same address.

then STOP is not generated.

The line will show: DADR BYTE 1, ..., BYTE n, NO STOP generated, BYTE 1, ..., BYTE n.

Problem Fix/Workaround

Insert a delay of one TWI clock period before step 4 in the sequence above.

42.2.16 UDP

42.2.16.1 UDP: Bad data in the first IN data stage

All or part of the data of the first IN data Stage are not transmitted. It may then be a Zero Length Packet. The CRC is correct. So the HOST may only see that the size of the received data does not match the requested length. But even if performed again, the control transfer will probably fail.

Problem Fix/Workaround

These Control transfers are mainly used at device configuration. After clearing RXSETUP, the software needs to compute the setup transaction request before writing data into the FIFO if needed. This time is generally greater than the minimum safe delay required above. If not, a software wait loop after RXSETUP clear may be added at minimum cost

42.2.17 UHP

42.2.17.1 UHP: Non-ISO IN transfers

Conditions:

Consider the following sequence:

1. The Host controller issues an IN token.
2. The Device provides the IN data in a short packet.
3. The Host controller writes the received data to the system memory.
4. The Host controller is now supposed to carry out two Write transactions (TD status write and TD retirement write) to the system memory in order to complete the status update.
5. The Host controller raises the request for the first write transaction. By the time the transaction is completed, a frame boundary is crossed.
6. After completing the first write transaction, the Host controller skips the second write transaction.

Consequence: When this defect manifests itself, the Host controller re-attempts the same IN token.

Problem Fix/Workaround

This problem can be avoided if the system guarantees that the status update can be completed within the same frame.

42.2.17.2 UHP: ISO OUT transfers

Conditions:

Consider the following sequence:

1. The Host controller sends an ISO OUT token after fetching 16 bytes of data from the system memory.
2. When the Host controller is sending the ISO OUT data, because of system latencies, remaining bytes of the packet are not available. This results in a buffer underrun condition.

3. While there is an underrun condition, if the Host controller is in the process of bit-stuffing, it causes the Host controller to hang.

Consequence: After the failure condition, the Host controller stops sending the SOF. This causes the connected device to go into suspend state.

Problem Fix/Workaround

This problem can be avoided if the system can guarantee that no buffer underrun occurs during the transfer.

42.2.17.3 UHP: Remote Wakeup event

Conditions:

When a Remote Wakeup event occurs on a downstream port, the OHCI Host controller begins sending resume signaling to the device. The Host controller is supposed to send this resume signaling for 20 ms. However, if the driver sets the HcControl.HCFS into USBOPERATIONAL state during the resume event, then the Host controller terminates sending the resume signal with an EOP to the device.

Consequence: If the Device does not recognize the resume (<20 ms) event, then the Device will remain in suspend state.

Problem Fix/Workaround

Host stack can do a port resume after it sets the HcControl.HCFS to USBOPERATIONAL.

42.2.18 USART

42.2.18.1 USART: CTS signal in Hardware Handshake

When Hardware Handshaking is used and if CTS goes low near the end of the starting bit of the transmitter, a character is lost.

Problem Fix/Workaround

CTS must not go low during a time slot comprised between 2 Master Clock periods before the rising edge of the starting bit and 16 Master Clock periods after the rising edge of the starting bit.

42.2.18.2 USART: RTS unexpected behavior

1. Setting the receiver to hardware handshaking mode drops RTS line to low level even if the receiver is still turned off. USART needs to be completely configured and started before setting the receiver to hardware handshaking mode.
2. Disabling the receiver during a PDC transfer while RXBUFF flag is '0' has no effect on RTS. The only way to get the RTS line rising to high level is to reset both PDMA buffers by writing the value '0' in both counter registers.

Problem Fix/Workaround

None.

42.2.18.3 USART: TXD signal is Floating in Modem and Hardware Handshaking Mode

TXD signal should be pulled up in Modem and Hardware Handshaking mode.

Problem Fix/Workaround

TXD is multiplexed with a PIO which integrates a pull-up resistor. This internal pullup needs to be enabled.

42.2.18.4 USART: DCD is Active High Instead of Low

DCD signal is active at "High" level in USART block (Modem Mode).

DCD should be active at "Low" level.

Problem Fix/Workaround

Add an inverter.

43. Revision History

In the tables that follow, the most recent version of the document appears first. The initials “rfo” indicate changes requested by product experts, or made during proof reading as part of the approval process.

Table 43-1. Revision History - SAM9261 Datasheet Revision 60820

| Date | Comments |
|-----------|---|
| 21-Jun-16 | <p>General formatting and editorial changes throughout</p> <p>Several instances of “AT91SAM9261” changed to “SAM9261”</p> <p>Throughout, instances of “32768 Hz” and “32,768 Hz” changed to “32.768 kHz”</p> |
| | <p>“Features”</p> <p>Deleted bullet “Required Power Supplies”</p> |
| | <p>Section 1. “Block Diagram”</p> <p>Figure 1-1 “SAM9261 Block Diagram”: added label “Backup Section”; updated oscillator naming; “GPBREG” changed to “GPBR (16 bytes)”</p> |
| | <p>Section 3. “Package and Pinout”</p> <p>Table 3-1 “SAM9261 Pinout for 217-ball LFBGA Package”: added footnote “NC pins must be left unconnected.”</p> |
| | <p>Section 4. “Power Considerations”</p> <p>Added Section 4.2 “Power Sequence Requirements” (transferred from Section 38.7 “Core Power Supply POR Characteristics”) and updated content</p> <p>Removed section “Power Consumption” (redundant with Section 38.3 “Power Consumption”)</p> |
| | <p>Section 7. “Memories”</p> <p>Updated Section 7.1.2.1 “BMS = 1, Boot on Embedded ROM”</p> |
| | <p>Section 8. “System Controller”</p> <p>Updated Section 8.3 “Shutdown Controller”</p> <p>Updated Section 8.7 “Periodic Interval Timer”</p> <p>Updated Section 8.8 “Watchdog Timer”</p> <p>Updated Section 8.9 “Real-time Timer”</p> <p>Updated Section 8.11 “Debug Unit”</p> |
| | <p>Section 9. “Peripherals”</p> <p>Table 9-1 “Peripheral Identifiers”: “SYSIRQ / System Interrupt” changed to “SYSC / System Controller Interrupt”</p> <p>Updated Section 9.8 “Two-wire Interface”</p> <p>Updated Section 9.11 “Timer Counter”</p> <p>Updated Section 9.12 “Multimedia Card Interface”</p> <p>Updated Section 9.13 “USB”</p> |
| | <p>Section 10. “ARM926EJ-S Processor”</p> <p>Table 10-1 “ARM9TDMI™ Modes and Registers Layout” renamed to “ARM9EJ-S Modes and Registers Layout”</p> |
| | <p>Section 12. “Boot Program”</p> <p>Section 12.1 “Description”: “root directory of a FAT12/16/32 formatted SD Card” changed to “root directory of a FAT12/16/32 formatted SD Card on Slot A”</p> <p>Updated Section 12.4.2.1 “Example”</p> <p>Section 12.7 “NAND Flash Boot”: in first paragraph, inserted “The first block must be guaranteed by the manufacturer. There is no ECC check.”</p> <p>Section 12.8 “SD Card Boot”: added “(Boot ROM does not support high capacity SDCards.)”</p> |

Table 43-1. Revision History - SAM9261 Datasheet Revision 60820

| Date | Comments |
|-----------|--|
| | <p>Section 12. "Boot Program" (cont'd)</p> <p>Section 12.10.3 "USB Device Port": deleted reference to "Windows XP"</p> <p>Section 12.11 "Hardware and Software Constraints": added note "Boot ROM does not support high capacity SDCards."</p> |
| | <p>Section 13. "Reset Controller (RSTC)"</p> <p>Added Section 13.2 "Embedded Characteristics"</p> |
| | <p>Section 14. "Real-time Timer (RTT)"</p> <p>Added Section 14.2 "Embedded Characteristics"</p> |
| | <p>Section 15. "Periodic Interval Timer (PIT)"</p> <p>Added Section 15.2 "Embedded Characteristics"</p> |
| | <p>Section 16. "Shutdown Controller (SHDWC)"</p> <p>Added Section 16.2 "Embedded Characteristics"</p> |
| | <p>Section 18. "Bus Matrix"</p> <p>Removed reset value from Section 18.5.3 "Bus Matrix TCM Configuration Register", Section 18.5.4 "EBI Chip Select Assignment Register" and Section 18.5.5 "USB Pad Pull-up Control Register" (reset values are provided in Table 18-1 "Register Mapping")</p> <p>Table 18-1 "Register Mapping": removed reset value from MATRIX_MCFG (register is write-only)</p> |
| 21-Jun-16 | <p>Section 19. "External Bus Interface (EBI)"</p> <p>Section 19.6.5.2 "CFCE1 and CFCE2 Signals": "The Chip Select Register (DBW field in the corresponding Chip Select Register) of the NCS4" corrected to "The DBW field in the SMC Mode Register corresponding to the NCS4"</p> |
| | <p>Section 20. "Static Memory Controller (SMC)"</p> <p>Updated Section 20.8.1.3 "Read Cycle" and Section 20.8.3.3 "Write Cycle"</p> <p>Updated Section 20.8.6 "Reset Values of Timing Parameters"</p> <p>Section 20.13.2 "Byte Access Type in Page Mode": "SMC_REGISTER" corrected to "SMC Mode Register"</p> |
| | <p>Section 21. "SDRAM Controller (SDRAMC)"</p> <p>Table 21-8 "Register Mapping": access "Read" corrected to "Read/Write" for SDRAMC_MDR</p> <p>Removed reset value from Section 21.6.1 "SDRAMC Mode Register", Section 21.6.2 "SDRAMC Refresh Timer Register", Section 21.6.3 "SDRAMC Configuration Register", and Section 21.6.4 "SDRAMC Low Power Register" (reset values are provided in Table 21-8 "Register Mapping")</p> |
| | <p>Section 22. "Peripheral DMA Controller (PDC)"</p> <p>Table 22-1 "Register Mapping": removed reset value from PERIPH_PTCR (register is write-only)</p> |
| | <p>Section 24. "Power Management Controller (PMC)"</p> <p>Section 24.7 "Programming Sequence": updated Step 5 "Selection of Master Clock and Processor Clock"</p> <p>Table 24-3 "Register Mapping": access for PMC_PLLICPR changed from "Write-only" to "Read/Write"</p> <p>Section 24.9.17 "PLL Charge Pump Current Register": access changed from "Write-only" to "Read/Write"</p> |
| | <p>Section 25. "Watchdog Timer (WDT)"</p> <p>Added Section 25.2 "Embedded Characteristics"</p> |
| | <p>Section 26. "Advanced Interrupt Controller (AIC)"</p> <p>Table 26-2 "Register Mapping": deleted footnote "Values in the Version Register vary with the version of the IP block implementation."</p> <p>Removed reset value from register description sections (reset values are provided in Table 26-2 "Register Mapping")</p> |

Table 43-1. Revision History - SAM9261 Datasheet Revision 60820

| Date | Comments |
|--|---|
| 21-Jun-16 | <p>Section 27. "Debug Unit (DBGU)"</p> <p>Added Section 27.2 "Embedded Characteristics"</p> <p>Table 27-2 "Register Mapping":</p> <ul style="list-style-type: none"> - added reset value 0x00181800 for DBGU_SR - added reset value 0x019703A0 for DBGU_CIDR |
| | <p>Section 28. "Peripheral Input/Output Controller (PIO)"</p> <p>Figure 28-3 "I/O Line Control Logic": redimensioned to display PIO_IDR[31] at bottom of diagram</p> |
| | <p>Section 30. "Two Wire Interface (TWI)"</p> <p>Added Section 30.2 "Embedded Characteristics"</p> <p>Table 30-4 "Register Mapping": removed reset value from TW_THR (register is write-only)</p> <p>Removed reset values from register description sections (reset values are provided in Table 30-4 "Register Mapping")</p> <p>Section 30.11.11 "TWI Transmit Holding Register": access "Read-write" corrected to "Write-only"</p> |
| | <p>Section 31. "Universal Synchronous Asynchronous Receiver Transmitter (USART)"</p> <p>Table 31-5 "Possible Values for the Fi/Di Ratio": in top row, replaced "774" with "744"</p> <p>Table 31-10 "IrDA Baud Rate Error": in header row, added "bit/s" to Baud Rate and added "µs" to Pulse Time</p> <p>Table 31-11 "Register Mapping": added reset value 0x0 to US_MR, US_CSR, US_NER</p> <p>Removed reset value from Section 31.7.12 "USART FI DI RATIO Register" (reset value provided in Table 31-11 "Register Mapping")</p> |
| | <p>Section 32. "Synchronous Serial Controller (SSC)"</p> <p>Section 32.6.1.1 "Clock Divider": deleted irrelevant and untitled Table 33-2 from end of section</p> |
| | <p>Section 33. "Timer Counter (TC)"</p> <p>Added Section 33.2 "Embedded Characteristics"</p> <p>Updated Table 33-2 "Channel Signal Description"</p> |
| | <p>Section 34. "MultiMedia Card Interface (MCI)"</p> <p>Added Section 34.2 "Embedded Characteristics"</p> <p>Updated Section 34.8.1 "Command - Response Operation"</p> |
| | <p>Section 35. "USB Host Port (UHP)"</p> <p>Added Section 35.2 "Embedded Characteristics"</p> |
| | <p>Section 36. "USB Device Port (UDP)"</p> <p>Add Section 36.2 "Embedded Characteristics"</p> <p>Restructured Table 36-3 "USB Transfer Events"</p> <p>Table 36-4 "Register Mapping": UDP_GLB_STAT reset value '0x0000_0000' corrected to '0x0000_0010'</p> |
| | <p>Section 37. "LCD Controller (LCDC)"</p> <p>Table 37-12 "Register Mapping": removed reset value from write-only registers</p> <p>Removed reset value from register description sections (reset values are provided in Table 37-12 "Register Mapping")</p> |
| <p>Section 38. "Electrical Characteristics"</p> <p>Table 38-1 "Absolute Maximum Ratings*": removed "Operating Temperature" line</p> <p>Table 38-6 "Master Clock Waveform Parameters": symbol "1/(t_{CPCK})" corrected to "1/(t_{CPMCK})"</p> | |

Table 43-1. Revision History - SAM9261 Datasheet Revision 60820

| Date | Comments |
|-----------|---|
| 21-Jun-16 | <p>Section 38. "Electrical Characteristics" (cont'd)</p> <p>Section 38.7 "Core Power Supply POR Characteristics": transferred power sequence requirements and powerup sequence content to Section 4.2 "Power Sequence Requirements")</p> <p>Table 38-7 "XIN Clock Electrical Characteristics": added "ns" as unit for t_{CHXIN} and t_{CLXIN}</p> <p>Updated Figure 38-2 "32 kHz Oscillator Schematic"</p> <p>Table 38-10 "Main Oscillator Characteristics": updated symbol and conditions for "Startup Time"</p> <p>Updated Figure 38-3 "Main Oscillator Schematic"</p> <p>Table 38-14 "Power-On-Reset Characteristics": updated conditions for "Threshold Voltage Rising"</p> <p>Added Section 38.10.1.1 "Maximum SPI Frequency"</p> <p>Added Section 38.10.1.3 "Timing Extraction"</p> <p>Section 38.10.3 "UDP and UHP Switching Characteristics": renamed figure and tables</p> |
| | <p>Section 39. "Mechanical Characteristics"</p> <p>Figure 39-1 "217-ball LFBGA Package Drawing": redimensioned to display entire drawing</p> <p>Table 39-4 "Package Reference": "JESD97 Classification" updated to "J-STD-609 Category"</p> |
| | <p>Section 41. "Ordering Information"</p> <p>Table 41-1 "SAM9261 Ordering Information":</p> <ul style="list-style-type: none"> - removed obsolete ordering code AT91SAM9261-CJ. - added "Carrier Type"; added ordering code AT91SAM9261B-CU-999 |
| | <p>Section 42. "Errata"</p> <p>Migrated 42.1 "Marking" to Section 40. "Marking"</p> <p>Section 42.1.3.1 "Boot ROM: Only DataFlash Boot Is Functional": changed title (was "Boot ROM: NAND Flash Boot is not Functional) and updated content</p> <p>Updated Section 42.1.8.1 "RSTC: Reset During SDRAM Accesses"</p> <p>Improved register and field naming in Section 42.1.10 "Serial Peripheral Interface (SPI)"</p> <p>Added Section 42.1.12.2 "SHDWC: Bad Behavior of Shutdown Pin"</p> <p>Added Section 42.2.3.3 "Boot ROM: Code Size Limitation for DataFlash and Serial Flash Boot"</p> <p>Updated Section 42.2.8.1 "RSTC: Reset During SDRAM Accesses"</p> <p>Improved register and field naming in Section 42.2.10 "Serial Peripheral Interface (SPI)"</p> <p>Added Section 42.2.12.2 "SHDWC: Bad Behavior of Shutdown Pin"</p> |

| Doc. Rev. | Comments | Change Request Ref. |
|-----------|---|---------------------|
| 6062N | <p>Electrical Characteristics:</p> <p>Table 38-3 "Power Consumption for Different Modes", updated Full Speed conditions & consumption.</p> <p>Table 38-5 "Processor Clock Waveform Parameters", removed 240 MHz CPU configuration.</p> <p>Table 38-6 "Master Clock Waveform Parameters", removed 120 MHz MCK configuration.</p> | 7346 |
| | <p>Table 38-21 "Capacitance Load for MISO, SPCK and MOSI", STH column removed.</p> <p>Table 38-22 "SPI Timings", STH lines removed.</p> | 8003 |
| | <p>Back page:</p> <p>Latest back page file used.</p> | rfo |

| Doc. Rev. | Date | Comments | Change Request Ref. |
|-----------|-----------|--|---------------------|
| 6062M | 15-Mar-09 |  <p>Section 7.1.2.1 “BMS = 1, Boot on Embedded ROM”, updated</p> <p>Section 12. “Boot Program”, updated.</p> <p>Section 41. “Ordering Information”, updated with ordering information for chip revision B.</p> <p>Errata:</p> <p>Section 42.2 “SAM9261 Errata - Revision B Parts”, added to errata.</p> | 5424/rfo |
| | | <p>Section 42.1.8 “Reset Controller (RSTC)”</p> <p>Section 42.1.8.1 “RSTC: Reset During SDRAM Accesses”, added to Rev A parts errata.</p> <p>Section 42.2.8 “Reset Controller (RSTC)”</p> <p>Section 42.2.8.1 “RSTC: Reset During SDRAM Accesses”, added to Rev B parts errata.</p> | 6082 |
| | | <p>Section 41. “Ordering Information”, updated with ordering information for chip revision B.</p> | 5424 |
| | | <p>Electrical Characteristics:</p> <p>Section 38.7 “Core Power Supply POR Characteristics” added to datasheet.</p> | rfo |
| | | <p>Table 38-7 “XIN Clock Electrical Characteristics”, V_{IN} added to table.</p> | 6164 |

| Doc. Rev. | Date | Comments | Change Request Ref. |
|-----------|-----------|---|---------------------|
| 6062L | 08-Jan-09 | <p>Overview:</p> <p>“Features”</p> <p>Debug Unit (DBGU) updated</p> <p>Section 9.9 “USART”, manchester encoding option is not available.</p> | 5846 5932 |
| | | <p>DBGU:</p> <p>Section 27.1 “Overview”, The Debug Unit two-pin UART can be used stand-alone for general purpose serial communication.</p> | 5846 |
| | | <p>Electrical Characteristics:</p> <p>Table 38-2 “DC Characteristics”, “SHDN” added to Characteristics of I_O/Output Current Parameters.</p> | 5824 |

| Doc. Rev. Date | Comments | Change Request Ref. |
|-----------------|---|---|
| 6062L 08-Jan-09 |  <p>Errata:</p> <p>Section 42.1.1 "Main Oscillator"</p> <p>Section 42.1.1.1 "Main Oscillator: Spurious Malfunction of Main Oscillator", added to errata.</p> <p>Section 42.1.3 "Boot ROM"</p> <p>Section 42.1.3.4 "Boot ROM: UDP Pad Pull-up Enable", added to errata</p> <p>Section 42.1.13 "Static Memory Controller (SMC)"</p> <p>Section 42.1.13.1 "SMC: Chip Select Parameters Modification", added to errata.</p> <p>Section 42.1.10 "Serial Peripheral Interface (SPI)"</p> <p>Section 42.1.10.7 "SPI: Software Reset Must be Written Twice" added to errata.</p> | <p>5960</p> <p>6002</p> <p>5642</p> <p>5956</p> |

| Doc. Rev. Date | Comments | Change Request Ref. |
|-----------------|---|--|
| 6062K 27-Aug-08 |  <p>New!!! Address Offsets added to register tables in User Interface sections of the datasheet.</p> <p>AIC:</p> <p>Section 26.8.15 "AIC Spurious Interrupt Vector Register", fixed typo in bitfields.</p> <p>Section 26.6.3 "Interrupt Sources", Interrupt Source 1 OR-wiring description updated .</p> <p>Section 26.7.5 "Protect Mode", enabling Debug Control Protect Mode in AIC_DCR register updated.</p> <p>Debug and Test:</p> <p>Table 11-3 "SAM9261 JTAG Boundary Scan Register" Bit number 481 is assigned to Pin Name A19.</p> <p>GPBR:</p> <p>Section 17. "General Purpose Backup Register (GPBR)", added to the datasheet</p> | <p>rfo</p> <p>4749</p> <p>5191</p> <p>5193</p> <p>5530</p> <p>5764</p> |

| Doc. Rev. Date 6062K 27-Aug-08 | Comments (Continued) | Change Request Ref. |
|-----------------------------------|--|--|
| | <p>LCDC:</p> <p>Table 37-1 "I/O Lines Description", updated description of LCDDEN.</p> <p>Section 37.5.1.3 "Channel-U", Removed equations for STN Monochrome mode and STN Color mode. Updated definitions.</p> <p>Table 37-4 "Big Endian Memory Organization", Inverted Pixel 1bpp row values to go from 0 to 31.</p> <p>Section 37.10.23 "Power Control Register", LCD_PWR bit description, changed all occurrences of "pin" to "signal".</p> <p>Section 37.10.1 "DMA Base Address Register 1", updated with new values for bits 0 and 1.</p> <p>Section 37.5.2.7 "Shifter", fixed typo: "LDCCON3 register" corrected to read "LCDCON2 register"</p> <p>Section 37.9.2 "TFT Mode Example", HFP = (16-2), HBP = (48 -1), HPW = (64-1), typo corrected.</p> <p>"Horizontal Front Porch (HFP): The delay between end of valid data and the end of the line is configurable in the HFP field of the LCDCON2 register. The delay is equal to (HFP+2) LCDDOTCK cycles." on page 632.</p> <p>HFP+2 (not HFP+1) idem for</p> <p>Section 37.10.12 "LCD Timing Configuration Register 2"</p> <p>and the timing diagrams</p> <p>Figure 37-3 "STN Panel Timing, CLKMOD 0"</p> <p>Figure 37-4 "TFT Panel Timing, CLKMOD = 0, VPW = 2, VBP = 2, VFP = 1"</p> <p>Figure 37-5 "TFT Panel Timing (Line Expanded View), CLKMOD=1"</p> | <p>3587</p> <p>4268</p> <p>4488</p> <p>4739</p> <p>5619</p> <p>rfo</p> |
| | <p>PMC:</p> <p>Section 24.1 "Overview" • PCK must be switched off when entering processor in Idle Mode.</p> <p>Section 24.3 "Processor Clock Controller", updated with information on "Wait for Interrupt Mode".</p> <p>Figure 23-1 "Typical Slow Clock Crystal Oscillator Connection", GNDPLL changed to GNDBU.</p> <p>Section 24.7 "Programming Sequence", correction to Step 5, and Step 6, "....PRES parameter is set to 0..."</p> | <p>4322</p> <p>4470</p> <p>5596</p> |

| Doc. Rev. Date | Comments (Continued) | Change Request Ref. |
|-----------------|---|---------------------|
| 6062K 27-Aug-08 | RSTC: | |
| | Figure 13-4 "General Reset State" , updated | 4215 |
| | Section 13.4.4.1 "General Reset" , extensive update to this section. | 4250 |
| | Section 13.4.3 "BMS Sampling" and Figure 13-3 "BMS Sampling" added to datasheet | 4372 |
| | Section 13.4.4.4 "Software Reset" , PERRST must be used with PROCRST, except for debug purposes. | 5436 |
| | SHDWC: | |
| | Table 16-2 "Register Mapping" | |
| | SHDW_MR reset changed to 0x0000_0303. | 5727 |
| | SHDW_SR offset value is 0x08. | 4244 |
| | SDRAMC: | |
| | Section 21.6.1 "SDRAMC Mode Register" , changed MODE bit descriptions . | 4593 |
| | Section 21.6.3 "SDRAMC Configuration Register" Changed bit description for "CAS: CAS Latency". | 4623 |
| | SMC: | |
| | Section 20.8.5 "Coding Timing Parameters" , "Effective Value" column under "Permitted Range" updated in Table 20-4 . | 5604 |
| | Section 20.9.3.1 "User Procedure" , added instructions regarding configuration parameters of SMC Chip Select added | 5621 |
| | SPI: | |
| | Section 29.6.4 "SPI Slave Mode" , corrected information on OVRES (SPI_SR) and data read in SPI_RDR. | 3943 |
| | Section 29.7.9 "SPI Chip Select Register" , note pertaining to BITS field added. This note is referenced in the BITS bit field description and Section 29.6.4 "SPI Slave Mode" . | 5588 |
| | SSC: | |
| | Section 32.8.3 "SSC Receive Clock Mode Register" , Corrected name to STTDLY in bit fields 23 to 16. | 4778 |
| | TC: | |
| | Section 33.7 "Timer Counter (TC) User Interface" , previous Register Mapping tables consolidated in Table 33-4 "Register Mapping" as a result of indexed register scheme. | 4583 |
| | From Section 33.7.3 "TC Channel Control Register" to Section 33.7.13 "TC Interrupt Mask Register" , register names updated with indexed offset reference. Functional value of WAVE is given, when relevant, in Register Name or Access. | |
| | Section 33.7.2 "TC Block Mode Register" , typo corrected in bit fields 2 and 3. | |
| | Section 33.7.4 "TC Channel Mode Register: Capture Mode" , bit field 15 updated. | |
| | Section 33.7.5 "TC Channel Mode Register: Waveform Mode" , bit field 15 updated. | |
| | TWI: | |
| | Section 30. "Two Wire Interface (TWI)" , extensive update to this section. | 5327 |

| Doc. Rev. Date | Comments (Continued) | Change Request Ref. |
|-----------------|---|---------------------|
| 6062K 27-Aug-08 | UDP: | |
| | Table 36-2 "USB Communication Flow" changed the value in the cell on the "interrupt line of the "Supported Endpoint Size" column. | 3476 |
| | Control endpoints are not effected by the "EPEDS: Endpoint Enable Disable" bit field in the UDP_CSR register. | 4063 |
| | Updated "write 1 =..." in "RX_DATA_BK0: Receive Data Bank 0" bit field of UDP_CSR register. | 4099 |
| | Updated "write 0 =..." in "TXPKTRDY: Transmit Packet Ready" bit field of UDP_CSR register. | |
| | Section 36.7.10 "UDP Endpoint Control and Status Register" , update to code and added instructions regarding USB clock and system clock cycle. | 4462/4487 |
| | Section 36.3 "Block Diagram" , text under the block diagram updated: MCK specified as clock used by Master Clock domain, UDPCK specified as 48 MHz clock used by 12 MHz domain, in peripheral clock requirements. | 4508 |
| | Table 36-4 "Register Mapping" , UDP_CSR, UDP_FDR updated with indexed register scheme, footnote added to UDP_ISR reset. | 4802 |
| | Section 36.7.6 "UDP Interrupt Mask Register" , bitfield 12 defined as BIT12, cannot be masked. | |
| | Table 36-4 "Register Mapping" , Reset vaule for UDP_RST_EP is 0x000_0000 | 5049 |
| | Table 36-1 "USB Endpoint Description" , footnote added to Dual-Bank heading. | |
| | Section 36.6.2.9 "Transmit Data Cancellation" , added. | |
| | Section 36.7.9 "UDP Reset Endpoint Register" , added steps to clear endpoints. | 5150 |
| | "TXPKTRDY: Transmit Packet Ready" , description in UDP_CSRx, updated "Write :0 =". | |
| | UHP: | |
| | Section 35.1 "Overview" , Added hyperlink to Open HCI Rev 1.0 Specification. http://h18000.www1.hp.com/productinfo/development/openhci.html . | 4364 |
| | USART: | |
| | Section 31.5.1 "I/O Lines" , added sentence on required use of internal pull up on TXD pertaining to hardware handshaking feature. | 4285 |
| | Section 31.6.2 "Receiver and Transmitter Control" , In the fourth paragraph, Software reset effects (RSTRX and RSTTX in US_CR register) updated by replacing 2nd sentence. | 4367 |
| | Section 31.6.3.1 "Transmitter Operations" , last paragraph updated. | rfo |
| | Section 31.6.5 "IrDA Mode" , updated with instructions to receive IrDA signals. | 4912 |
| | Electrical Characteristics: | |
| | Section 38.8 "EBI Timings" , Section 38.9 "SDRAMC Timings" , Section 38.10 "Peripheral Timings" extensive updates to these sections. | 5609 |
| | Section 39.7 Core Power Supply POR Characteristics removed, subsequent number has changed. | 5795 |
| | Table 38-17 "SMC Write Signals with Hold Settings" SMC ₂₃ and SMC ₃₄ : in "Min" columns, -1 removed from (NWE pulse length). | |
| | Table 38-18 "SMC Write Signals with No Hold Settings (NWE Controlled Only)" SMC ₄₀ : in "Min" columns, -1 removed from (NWE pulse length). | 5527 |
| | Figure 38-4 "USB Data Signal Rise and Fall Times" , R _{EWXT} = 27 Ohms. | 5612 |
| | Mechanical Characteristics: | |
| | Table 39-1, "Soldering Information (Substrate Level)" , on page 696, updated. | 5822 |

| Doc. Rev. Date | Comments (Continued) | Change Request Ref. |
|-----------------|---|---------------------|
| 6062K 27-Aug-08 | Revision History: Doc. Rev., "6062H", Change Request Ref., "4241", removed : "PA30 - PA31 power supplies are VDDIOM." | 5333 |

| Doc. Rev. Date | Comments | Change Request Ref. |
|-----------------|---|---------------------|
| 6062J 20-Mar-08 | Section 30. "Two-wire Interface (TWI)" important update to this section | 5327 |
| | Table 3-1 on page 9, PC16 is powered by VDDIOM in Pinout for LFBA package | 5382 |
| | Table 38-8 "32 kHz Oscillator Characteristics" VDDOSC changed to VDDBU | 5334/5440 |
| | Section 12.11 "Hardware and Software Constraints","downloaded code size must be smaller than 156 Kbytes"."time to down load 156 Kbytes is reduced to 200 ms." | 5397 |
| | Removed Section 41.3 "AT91SAM9261 Errata-Revision B Parts". | 5464 |

| Doc. Rev. Date | Comments | Change Request Ref. |
|-----------------|---|---------------------|
| 6062I 06-Feb-08 | "Errata", added Section 41.3 "AT91SAM9261 Errata - Revision B Parts" | 5167 |
| | Section 42.1.5 "LCD" added to Section 42.1 "SAM9261 Errata - Revision A Parts" | rfo review |
| | Section 42.1.12 "Shutdown Controller (SHDWC)" added to errata. | 5263 |
| | Section 4.1 "Power Supplies", startup voltage slope requirements for VDDCORE and VDDBU removed. | 5228 |
| | Section 39.7 "Core Power Supply POR Characteristics" added to Electrical Characteristics subsequent chapter, table and figure numbering advanced. | 5250 |
| | Table 38-2 "DC Characteristics" VIH updated. | 4928 |
| | VOL and VOH updated | 5287 |
| | Section 38.9 "Peripheral Timings" In the SPI section. figure titles updated as follows. Figure 38-7 "SPI Master Mode with (CPOL =0 and NCPHA = 1) or (CPOL =1 NCPHA = 0)" Figure 38-8 "SPI Master Mode with (CPOL = NCPHA = 0) or (CPOL = NCPHA = 1)" | 5259 |
| | Features: "Package" on page 3, updated, 3.0V to 3.6V for VDDOSC and for VDDPLL. | 5248 |

| Doc. Rev. 6062H | Date 13-Nov-07 | Comments | Change Request Ref. |
|---|---|--|---------------------|
|  | Overview: | Table 9-4, "Multiplexing on PIO Controller C," on page 33, PCO - PC7 power supplies are VDDIOP not VDDIOM. | 5042 |
| | Section 7.1.2 "Boot Strategies" , removed sentence pertaining to "remap" | | 5027 |
| | Section 7.1.2.2 "BMS = 0, Boot on External Memory" , "NANDFlash Boot" added to list. | | rfo |
| | Section 4.1 "Power Supplies" , startup voltage slope requirements for VDDCORE and VDDBU added. | | 4965 |
| | Table 9-3, "Multiplexing on PIO Controller B," on page 32, Note added to "PB3" comments | | 4844 |
| | Figure 8-3, "Power Management Controller Block Diagram," on page 26 , in the master memory controller representation, the divider has been updated. | | 4835 |
| | Table 3-1 on page 9, PCO - PC7, PC8 - PC11, PC14 - PC15 power supplies are VDDIOP not VDDIOM. | | 4241 |
| | Boot Program | | |
| | Section 12.1 "Description" , updated. | | rfo |
| | Section 12.7 "NAND Flash Boot" , added to Boot Program. | | rfo |
| | Figure 12-3 "LDR Opcode" , updated. | | 4452 |
| | Section 12.11 "Hardware and Software Constraints" , updated | | rfo |
| | BUS Matrix: | | |
| | Section 18.5.4 "EBI Chip Select Assignment Register" EBI_DBPUCD :bits pulled up to the VDDIOM power supply. | | 4467 |
| PMC | | | |
| Section 24. "Clock Generator" removed reference to RC Oscillator | | 5065 | |
| Section 24.4.2 "Divider and Phase Lock Loop Programming" , last sentence added. | | 4839 | |
| Section 24.7 "Programming Sequence" , 2nd sentence in step 3 and step 4 added. | | | |
| RSTC | | | |
| Figure 14-1 "Reset Controller Block Diagram" There is one block diagram. | | 4565 | |
| Section 14.3.2 "NRST Manager" , the brownout manager figure has been removed | | | |
| SHDW | | | |
| Section 18.2 "Block Diagram" , updated | | 4733 | |
| Table 18-2, "Register Mapping," updated | | | |
| Electrical/Mechanical Characteristics | | | |
| Section 38.2 "DC Characteristics" , removed reference to junction temperature | | 4729 | |
| Section 39. "Mechanical Characteristics" , "Thermal Considerations" removed | | | |
| Table 38-8 "32 kHz Oscillator Characteristics" $V_{DDOSC} = 1.2V$ | | 4243 | |
| Section 38.5.2 "32 kHz Crystal Characteristics" , added to datasheet | | 4836 | |
| Section 38.4.2 "Master Clock Characteristics" , added to datasheet | | 4302 | |
| Table 38-2, "DC Characteristics," Typical values assigned. | | 5003 | |

| Doc. Rev. 6062H | Date 13-Nov-07 | Comments (Continued) | Change Request Ref. |
|--------------------|-------------------|---|---------------------|
| | | Errata: The following have been added. Section 42.1.3.1 "Boot ROM: Only DataFlash Boot Is Functional" | rfo |
| | | Section 42.1.11.1 "SSC: Transmitter Limitations in Slave Mode" Section 42.1.11.3 "SSC: Last RK Clock Cycle when RK Outputs a Clock During Data Transfer" , Section 42.1.11.4 "SSC: First RK Clock Cycle when RK Outputs a Clock During Data Transfer" | 4770 |
| | | Section 42.1.9.2 "SDRAM: JEDEC Standard Compatibility" | 4218 |
| | | Section 42.1.9.3 "SDRAM: Mobile SDRAM Device Initialization Constraint" | 4639 |
| | | Section 42.2.15.3 "USART: TXD signal is Floating in Modem and Hardware Handshaking Mode" | 4719 |
| | | Section 42.2.15.4 "USART: DCD is Active High Instead of Low" | |

| Doc. Rev. 6062G | Date 22-Feb-07 | Comments | Change Request Ref |
|--------------------|-------------------|---|--------------------|
| | | Updated Section 9.6 "Power Management Controller" on page 25 and Figure 9-3, "Power Management Controller Block Diagram," on page 25. | 3491 |
| | | EBI: In Table 19-4, "EBI Pins and External Devices Connections," on page 135, added Note ⁽³⁾ on CE connection and NAND Flash. | 3894 |
| | | BootROM: Updated DataFlash support in Table 13-2, "DataFlash Device," on page 84. | 4183 |
| | | RSTC: In Section 13.4.1 "Reset Controller Overview" on page 88 added information on startup counter for crystal oscillator. | 3005 |
| | | SMC: Added information on boot in Section 20.7.2.1 "Byte Write Access" on page 158. | 3252 |
| | | SDRAMC: Change to Step 5 in Section 21.4.1 "SDRAM Device Initialization" on page 196; addition of note ⁽¹⁾ on page 196. | 3305 |
| | | PMC: Updated Figure 23-1, "Typical Slow Clock Crystal Oscillator Connection," on page 231 and Figure 23-3, "Typical Crystal Connection," on page 232. | 3861 |
| | | Updated Section 23.3.1 "Main Oscillator Connections" on page 232. | 3832 |
| | | Updated information on HClocks in Section 24.1 "Overview" on page 235. | 3491 |
| | | Updated information on enable/disable in Section 24.3 "Processor Clock Controller" on page 236. | 3835 |
| | | PIO: Figure 28-3, "I/O Line Control Logic," on page 329 change to I/O Line Control Logic. | 3053 |
| | | Section 28.4.5 "Synchronous Data Output" on page 331, PIO_OWSR typo corrected. | |
| | | Section 28.6 "Parallel Input/Output Controller (PIO) User Interface" on page 335, footnotes updated on PIO_PSR, PIO_ODSR, PIO_PDSCR in Register Mapping table. | 3289 |
| | | | 3974 |

| Doc. Rev. 6062G | Date 22-Feb-07 | Comments (Continued) | Change Request Ref |
|--------------------|-------------------|---|--------------------|
| | | TC: Added information on compare register B and waveform generation in Section 33.6.12 "External Event/Trigger Conditions" on page 527 . Added Note ⁽¹⁾ to Register Bit Description "EVT: External Event Selection" on page 535 in "TC Channel Mode Register: Waveform Mode" on page 534 to further clarify. | 2704 |
| | | Added Figure 33-2, "Clock Chaining Selection," on page 517 to demonstrate clock chaining. | 3342 |
| | | UHP: Corrected signal name in block diagram Figure 35-1 on page 582 to UHPCK. | 2924 |
| | | Updated schematic Figure 35-4, "Board Schematic to Interface UHP Device Controller," on page 585 and added text on termination serial resistor in Section 35.6 "Typical Connection" on page 585 . | 3365 |
| | | UDP: All sections and information on wake-up/remote wake-up updated. | |
| | | Section 36.7.10 "UDP Endpoint Control and Status Register" on page 614 , changes to Write and Read values in FORCESTALL bit . | 3048 |
| | | Section 36.7.2 "UDP Global State Register" on page 604 activity of ESR and RMWUPE bits updated. | 3055 |
| | | Note added to TXVDIS bit description in Section 36.7.12 "UDP Transceiver Control Register" on page 620 describing USB pullup effect on USB reset. | |
| | | In Table 38-2, "DC Characteristics," on page 633 , updated static current value for $V_{VDDCORE} = 1.2V$. In Table 38-3, "Power Consumption for Different Modes," on page 678 , updated Quasi static current value for $V_{VDDCORE} = 1.2V$. | 3806 |
| | | In Table 38-3, "Power Consumption for Different Modes," on page 678 , added Note ⁽¹⁾ on SRAM access in Idle Mode. | 3903 |
| | | Updated Table 38-8, "32 kHz Oscillator Characteristics," on page 680 and Table 38-10, "Main Oscillator Characteristics," on page 681 with new information on capacitances. | 4065 |
| | | Errata: Updated Section 42.1.3.3 "Boot ROM: Temperature Range" on page 701 . Added Section 42.1.7.1 "NTRST: Device does not boot correctly due to powerup sequencing issue" on page 703 . Removed <i>SSC: Transmitter Limitations in Slave Mode</i> errata. | 4094 3881 |

| Doc. Rev. 6062F | Date 01-Dec-06 | Comments | Change Request Reference |
|--------------------|-------------------|---|--------------------------|
| | | Updated VDDOSC, VDDPLL and VDDIOM ranges in "Features", Table 3-1, "Signal Description by Peripheral," on page 5 , Section 5.2 "Power Consumption" on page 11 and Table 38-2, "DC Characteristics," on page 635 . | 3660, 3695, 3690 |
| | | Added ROM to Figure 8-1, "AT91SAM9261 Memory Mapping," on page 16 . | 3660 |
| | | All values changed in Table 38-1, "Absolute Maximum Ratings*," on page 635 . | 3697 |
| | | Updated values in Table 38-5, "Processor Clock Waveform Parameters," on page 638 . | 3687 |

| Doc. Rev. | Date | Comments | Change Request Reference |
|-----------|-----------|--|--------------------------|
| 6062E | 29-Sep-06 | Changed pin name for ball D9 to SHDN in Table 4-1, "AT91SAM9261 Pinout for 217-ball LFBGA Package (1)," on page 10. | 3068 |
| | | Updated peripheral mnemonics in Figure 8-1, "AT91SAM9261 Memory Mapping," on page 16. | 3067 |
| | | Updated information on shutdown pin in Section 6.5 "Shutdown Logic Pins" on page 12. | 3147 |
| | | Added note to Table 10-1, "Peripheral Identifiers," on page 29. | 3503 |
| | | Boot Program: In Section 13. "AT91SAM9261 Boot Program" on page 81, removed all references to NAND Flash boot feature. Not supported in the product. | 3307 |
| | | Boot Program: Modified number of instructions and vectors in Figure 13-6, "Serial DataFlash Download," on page 85. Modified SAM-BA boot principle in Section 12.10 "SAM-BA Boot" on page 83. | 3076 |
| | | EBI: Updated NAND Flash device pins in Table 19-4, "EBI Pins and External Devices Connections," on page 135. | 3316 |
| | | UDP: Corrected Section 36.4 "Product Dependencies" on page 587 on VBUS and I/O lines. | 3165 |
| | | Electrical Characteristics: Added note to Table 38-5, "Processor Clock Waveform Parameters," on page 638. | 3177 |
| | | Electrical Characteristics: Added Load Capacitance parameter to Table 38-7, "32 kHz Oscillator Characteristics," on page 639. | 3385 |
| | | Electrical Characteristics: Removed oscillator consumption value from Table 38-8, "Main Oscillator Characteristics," on page 640. | 3222 |
| | | Removed Internal Load Capacitance, Equivalent Load Capacitance and CLEXT parameters. Added Crystal Load Capacitance and External Load Capacitance parameters. | 3332 |
| | | Electrical Characteristics: Updated values for SDRAM20, SDRAM21 and SDRAM22 in Table 38-19, "SDRAMC Signals," on page 649. | 3150 |
| | | Electrical Characteristics: Added Section 38.8 "Peripheral Timings" , Section 38.8.1 "SPI" on page 652 and Section 38.8.2 "MCI" on page 654. | 3428 |
| | | Errata: Added errata Section 42.1.4.1 "Bus Matrix: Problem with locked transfers261" on page 701 Section 42.1.6.1 "MCI: Busy signal of R1b responses is not taken in account" on page 702 | 3331 |

| Doc. Rev. 6062D | Date 14-Apr-06 | Comments | Change Request Reference |
|--------------------|-------------------|---|--------------------------|
| | | Updated information on JTAGSEL in Section 3-1 "Signal Description by Peripheral" on page 5 and in Section 6.1 "JTAG Port Pins" on page 11 . | 2946 |
| | | Reformatted Section 8. "Memories" on page 16 . Inserted new Figure 8-1, "AT91SAM9261 Memory Mapping," on page 16 to show full product memory mapping. | 2475 |
| | | Inserted new Section 8.1.2 "Boot Strategies" on page 20 to replace Boot ROM section. | 2480 |
| | | Removed information on Timer Counter clock assignments in Section 10.11 "Timer Counter" on page 37 . | 2474 |
| | | In section Debug and Test, added Section 11.5.3 "JTAG Signal Description" on page 57 . | 2557 |
| | | RSTC: In Section 14.3.1 "Reset Controller Overview" on page 95 , added information on startup counter. | 3005 |
| | | RTT: Added note to Section 14.4 "Functional Description" on page 95 giving information on asynchronism between SCLK and MCK. | 2522 |
| | | SHDWC: In Section 18.5 "Functional Description" on page 126 added "The shutdown is taken into account only 2 slow clock cycles after the write of SHDW_CR." | 2549 |
| | | Bus Matrix: Removed bits RCB4, RCB3 and RCB2 from MATRIX_MCFG in Section 18.5.1 "Bus Matrix Master Configuration Register" on page 126 . | 2731 |
| | | EBI: Added Section 19.7 "Implementation Examples" on page 145 . | |
| | | PMC: Updated OUTx bit descriptions in Section 25.10.9 "PMC Clock Generator PLL A Register" on page 270 and Section 25.10.10 "PMC Clock Generator PLL B Register" on page 271 . | 2467 |
| | | PMC: Added note defining PIDx in Section 25.10.4 "PMC Peripheral Clock Enable Register" on page 266 , Section 25.10.5 "PMC Peripheral Clock Disable Register" on page 266 and Section 25.10.6 "PMC Peripheral Clock Status Register" on page 267 . | 2468 |
| | | PMC: Updated document to with details on oscillator selection. Added bit OSCSEL to Section 25.10.15 "PMC Status Register" on page 275 . | 2558 |
| | | PMC: Addition of PLL Charge Pump Current Register in Table 25-3, "Register Mapping," on page 262 and Section 25.10.17 "PLL Charge Pump Current Register" on page 277 . | 2568 |
| | | AIC: Section 26.7.3.1 "Priority Controller" on page 276 , incorrect reference of SRCTYPE field to AIC_SVR register changed to AIC_SMR register. | 2512 |
| | | AIC: Section 26.8 "Advanced Interrupt Controller (AIC) User Interface" on page 282 , Table 26-2 added note in reference to PID2...PID31 bit fields. | 2548 |
| | | AIC: Naming convention for AIC_FVR register harmonized in Table 26-2, "Register Mapping," on page 282 and "Fast Forcing" on page 279 . | 2524 |
| | | DBGU: In Figure 27-1, "Debug Unit Functional Block Diagram," on page 304 , changed signal ice_reset to pad Power_on Reset. Also changed in bit description FNTRST in Section 27.5.12 "Debug Unit Force NTRST Register" on page 325 . | |
| | | USART: MANE bit removed from Section 31.7.3 "USART Interrupt Enable Register" on page 432 . | 2747 |
| | | USART: Section 31.5.1 "I/O Lines" on page 402 , text concerning TXD line added. Table 31-3, "Binary and Decimal Values for Di," on page 406 and Table 31-4, "Binary and Decimal Values for Fi," on page 406 DI and Fi properly referenced in titles. Figure 31-24, "IrDA Demodulator Operations," on page 422 modified. | 2794 |
| | | TC: Addition of Table 33-1, "Timer Counter Clock Assignment," on page 483 . | 2470 |

| Doc. Rev. | Date | Comments (Continued) | Change Request Reference |
|-----------|-----------|---|--------------------------|
| 6062D | 14-Apr-06 | TC: Section 33.5.12 "External Event/Trigger Conditions" on page 496 new text as follows: "...(EEVT = 0), TIOB is no longer used as an output and the compare register B is not used to generate waveforms and subsequently no IRQs." Added note ⁽¹⁾ to EEVT bit description in Section 33.6.5 "TC Channel Mode Register: Waveform Mode" on page 504. | 2704 |
| | | MCI: Specified reset condition for DCRCE and DTOE bits in Section 34.10.10 "MCI Status Register" on page 572. | 2593 |
| | | MCI: Update to Figure 34-9, "Write Functional Flow Diagram," on page 558 in case of write with PDC. Addition of Figure 34-10, "Multiple Write Functional Flow Diagram," on page 559. | 2462 |
| | | UHP: Corrected signal name and corrected ASB bus to ASB bus in Figure 35-1, "Block Diagram," on page 545 to UHPCK. | 2924 |
| | | LCDC: Corrected typos in signal names in Figure 37-4, "TFT Panel Timing, CLKMOD = 0, VPW = 2, VBP = 2, VFP = 1," on page 598. | 2402 |
| | | LCDC: Removed references to AHB and LCDC clock domains in Figure 37-1, "LCD Macrocell Block Diagram," on page 586. | 2424 |
| | | LCDC: Updated Section 37.9 "Register Configuration Guide" on page 610. | 2426 |
| | | LCDC: Modified signal names throughout to be consistent with device: LCD_VSYNC changed to LCDVSYNC, LCD_HSYNC changed to LCDHSYNC, LCD_PCLK changed to LCDDOTCK, LCD_DVAL changed to LCDDEN, LCD_CC changed to LCDCC. Removed all references to LCD_MOD and LCD_PWR as these signals are not bonded in the device: Table 37-1, "I/O Lines Description," on page 587, Section 37.5.2.3 "Timegen" on page 595, Section 37.5.2.4 "Display" on page 600, Section 37.7 "Configuration Sequence" on page 607, Section 37.9.1 "STN Mode Example" on page 610, Section 37.9.2 "TFT Mode Example" on page 610, Table 37.10, "LCD Controller (LCDC) User Interface," on page 611 and removed LCDMOD Toggle Rate Value Register. | 2763 |
| | | Electrical Characteristics: Corrected typ value for R _{PULLUP} in Table 38-2, "DC Characteristics," on page 635. | 2457 |
| | | Electrical Characteristics: New Table 38-5, "Processor Clock Waveform Parameters," on page 638. Deleted table Master Clock Characteristics, page 638. New data for t _{ST} in Table 38-7, "32 kHz Oscillator Characteristics," on page 639. New data in Table 38-8, "Main Oscillator Characteristics," on page 640, I _{DDST} , P _{ON} , I _{DDON} , C _{LEXT} . New max values for t _{ST} . New Table 38-9, "Crystal Characteristics," on page 641. New data on pull-ups in Table 38-11, "USB Transceiver Electrical Parameters," on page 642. Deleted section "Applicable Conditions and Derating Data" and figures "Derating Curve for Different Operating Temperatures", "Derating Curve for Different Core Supply Voltages" and "Derating Curve for Different IO Supply Voltages". New tables with SMC and SDRAMC timings in Section 38.7 "EBI Timings" on page 644. New figures for SMC timings Figure 38-3, "SMC Signals for NCS Controlled Accesses," on page 647 and Figure 38-4, "SMC Signals for NRD and NWR Controlled Accesses," on page 648. | |
| | | In Table 38-19, "SDRAMC Signals," on page 649, some SDRAMx derating values changed from positive to negative. | 2619 |

| Doc. Rev. 6062D | Date 14-Apr-06 | Comments (Continued) | Change Request Reference |
|--------------------|-------------------|---|--------------------------|
| | | <p>Errata: Added:</p> <p>Section "All devices are marked with the Atmel logo and the ordering code." on page 1.</p> <p>Section 42.1.3.3 "Boot ROM: Temperature Range" on page 701</p> <p>Section 42.1.6.2 "MCI: Data Timeout Error Flag" on page 702</p> <p>Section 42.1.6.3 "MCI: STREAM command not supported" on page 702</p> <p>Section 42.1.6.4 "MCI: STOP during a WRITE_MULTIPLE_BLOCK command" on page 703</p> <p>Section 42.1.10.4 "SPI: Chip Select and fixed mode" on page 706</p> <p>Section 42.1.10.5 "SPI: Baud rate set to 1" on page 706</p> <p>Section 42.1.10.6 "SPI: Software Reset" on page 706</p> <p>Section 42.1.15.5 "TWI: Software reset" on page 709</p> <p>Section 42.1.15.6 "TWI: STOP not generated" on page 709,</p> <p>Section 42.2.15.2 "USART: RTS unexpected behavior" on page 703</p> <p>Section 42.2.17.1 "UDP: Bad data in the first IN data stage" on page 704</p> <p>Section 42.1.14.1 "SYSC: Possible event loss when reading RTT_SR" on page 708</p> <p>Section 42.1.2.1 "Backup Overconsumption during AHB Masters activity" on page 700.</p> <p>Removed errata: TWI: Behavior of OVRE bit and TWI: Clock Divider Limitation.</p> | |

| Doc. Rev. 6062C | Date 26-Jan-06 | Comments | Change Request Reference |
|--------------------|-------------------|---|--------------------------|
| | | Corrected MIPS and speed on page 1. | |
| | | Added information on EBI NCS0 when BMS = 0 in Table 8-3, "Internal Memory Mapping," on page 17. | 2292 |
| | | Removed note (3) regarding ALE and CLE signals from Table 20-4, "EBI Pins and External Devices Connections," on page 145. | 1729 |
| | | Corrected values for SMC_SETUP, SMC_PULSE, SMC_CYCLE and SMC_MODE registers in Table 21-5, "Reset Values of Timing Parameters," on page 181 and Table 21-9, "SMC Register Mapping," on page 202. | 1726 |
| | | Removed all references to High-speed Register in "SDRAM Controller (SDRAMC)" section. | |
| | | Corrected PRES description in Section 25.10.11 "PMC Master Clock Register" on page 262. | 1603 |
| | | SPI: Updated Figure 29-9, "Slave Mode Functional Bloc Diagram," on page 376 to remove FLOAD. | 1542 |
| | | SPI: Updated information on SPI_RDR in Section 29.6.3 "Master Mode Operations" on page 370. Added information to SWRST bit description in Section 29.7.1 "SPI Control Register" on page 378. Corrected equations in DLYBCT bit description on page 390. | 1543 |
| | | SPI: Changed Section 29.6.3.8 "Mode Fault Detection" on page 367. | 1676 |
| | | UDP: New documentation integrated. | |
| | | Errata: Added errata Section 41.5.3 "Disabling Does not Operate Correctly" on page 654 to Section 41.5.6 "Clock Divider Limitation" on page 655 and Section 41.7 "UHP" on page 655. | |

| Doc. Rev. | Date | Comments | Change Request Reference |
|-----------|-----------|---|--------------------------|
| 6062B | 14-Oct-05 | | |
| | | Changed SPI pin names in Figure 2-1, "AT91SAM9261 Block Diagram," on page 4, Table 3-1, "Signal Description by Peripheral," on page 5, Table 10-1, "Multiplexing on PIO Controller A," on page 30, Table 10-2, "Multiplexing on PIO Controller B," on page 31 and Table 10-3, "Multiplexing on PIO Controller C," on page 32. | 05-398 |
| | | Corrected EBI/Compact Flash interface description with updated A22 pin functionality in Figure 2-1, "AT91SAM9261 Block Diagram," on page 4, Figure 20-1, "Organization of the External Bus Interface," on page 131 and Table 20-6, "CFCE1 and CFCE2 Truth Table," on page 139. | 05-481 |
| | | Changed value of programmable pull-up resistor in Section 6.4 "PIO Controller A, B and C Lines" on page 12. | 05-496 |
| | | Bus Matrix: Corrected reset values of Slave Configuration Registers 0, 1 and 2 in Table 18-1, "Register Mapping," on page 125. | 05-498 |
| | | Bus Matrix: Updated bit information in Section 18.5.5 "USB Pad Pull-up Control Register" on page 130. | 05-486 |
| | | SMC: Corrected reset values of SMC_SETUP, SMC_CYCLE and SMC_MODE in Table 21-9, "SMC Register Mapping," on page 181. | 05-499 |
| | | SDRAMC: Removed Hardware Interface section from Section 22.4 "Application Example" on page 188. | 05-468 |
| | | SDRAMC: Updated Figure 22-2, "SDRAM Device Initialization Sequence," on page 191. | 05-479 |
| | | PMC: Updated Section 25.8 "Programming Sequence" on page 229. | 05-393 |
| | | PMC: Updated Figure 25-5, "Change PLLA Programming," on page 235 and added Figure 25-6, "Change PLLB Programming," on page 235. | 05-198 |
| | | PMC: Added important note on programming Bit 29 of CKGR_PLLAR in Section 25.8 "Programming Sequence" on page 229 and in Section 25.10.9 "PMC Clock Generator PLL A Register" on page 245. | 05-239 |
| | | AIC: Added information on external interrupt sources for bit SRCTYPE in Section 26.8.3 "AIC Source Mode Register" on page 267. | 05-269 |
| | | DBGU: Updated bit description for SRAMSIZ in Section 27.5.10 "Debug Unit Chip ID Register" on page 300. | 05-306 |
| | | PIO: Removed reference to resistor value in Section 28.4.1 "Pull-up Resistor Control" on page 331. | 05-497 |
| | | SPI: References to MCK/32 removed throughout. Figure 29-1, "Block Diagram," on page 338 and Figure 29-5, "Master Mode Block Diagram," on page 343 changed. | 05-484 |
| | | SPI: Section 29.7.5 "SPI Status Register" on page 356 SPI_RCR, SPI_RNCR, SPI_TCR, SPI_TNCR location defined. | 04-183 |
| | | SPI: Section 29.7.4 "SPI Transmit Data Register" on page 355, LASTXFER: Last Transfer text added. | 05-434 |
| | | SPI: Section 29.7.2 "SPI Mode Register" on page 352, PCSDEC: Chip Select Decode on changed | 05-476 |
| | | MCI: Corrected pin names in Figure 34-4, "MMC Bus Connections (One Slot)," on page 498. | 05-308 |
| | | UHP: Added information on memory access errors in "USB Host Port (UHP)" on page 522. | 05-240 |
| | | LCDC: Inserted FIFO size in "FIFO" on page 564 and in Section 37.10.14 "LCD FIFO Register" on page 598. | 05-381 |

| Doc. Rev. | Date | Comments (Continued) | Change Request Reference |
|-----------|-----------|---|--------------------------|
| 6062B | 14-Oct-05 | | |
| | | LCDC: Added information on PMC_SCER register in Section 37.4.2 "Power Management" on page 561. | 05-443 |
| | | Updated R _{PULLUP} values in Table 38-2, "DC Characteristics," on page 611. | Review |
| | | Corrected backup consumption value in Table 38-3, "Power Consumption for Different Modes(1)," on page 613. | 05-332 |
| | | Removed data on USB Transceiver Switching Characteristics at low speed in Section 38.6 "USB Transceiver Characteristics" on page 616. | Review |
| | | Corrected value of R _{EXT} in Figure 38-2, "USB Data Signal Rise and Fall Times," on page 617. | Review |
| | | Removed MTBF data from Section 40.1 "Thermal Considerations" on page 634. | 05-345 |
| | | Inserted Table 40-2, "Soldering Information," on page 635. | 05-347 |
| | | Updated Section 41. "AT91SAM9261 Ordering Information" on page 637. | 05-485 |
| | | Added Section 42. "AT91SAM9261 Errata" on page 638. | |

| Doc. Rev. | Date | Comments | Change Request Ref. |
|-----------|-----------|--------------|---------------------|
| 6062A | 02-Jun-05 | | |
| | | First issue. | |

Table of Contents

| | |
|--|----|
| Description | 1 |
| Features | 2 |
| 1. Block Diagram | 4 |
| 2. Signal Description | 5 |
| 3. Package and Pinout | 9 |
| 3.1 217-ball LFBGA Package Outline | 9 |
| 3.2 Pinout | 9 |
| 4. Power Considerations | 11 |
| 4.1 Power Supplies | 11 |
| 4.2 Power Sequence Requirements | 11 |
| 5. I/O Line Considerations | 13 |
| 5.1 JTAG Port Pins | 13 |
| 5.2 Test Pin | 13 |
| 5.3 Reset Pin | 13 |
| 5.4 PIO Controller A, B and C Lines | 13 |
| 5.5 Shutdown Logic Pins | 13 |
| 6. Processor and Architecture | 14 |
| 6.1 ARM926EJ-S Processor | 14 |
| 6.2 Debug and Test Features | 15 |
| 6.3 Bus Matrix | 15 |
| 6.4 Peripheral DMA Controller | 16 |
| 7. Memories | 17 |
| 7.1 Embedded Memories | 18 |
| 7.2 External Memories | 22 |
| 8. System Controller | 23 |
| 8.1 Block Diagram | 24 |
| 8.2 Reset Controller | 25 |
| 8.3 Shutdown Controller | 25 |
| 8.4 General-purpose Backup Registers | 25 |
| 8.5 Clock Generator | 25 |
| 8.6 Power Management Controller | 26 |
| 8.7 Periodic Interval Timer | 26 |
| 8.8 Watchdog Timer | 26 |
| 8.9 Real-time Timer | 26 |
| 8.10 Advanced Interrupt Controller | 27 |
| 8.11 Debug Unit | 27 |
| 8.12 PIO Controllers | 27 |
| 9. Peripherals | 28 |
| 9.1 User Interface | 28 |
| 9.2 Peripheral Identifiers | 28 |
| 9.3 Peripheral Multiplexing on PIO Lines | 29 |

| | | |
|------------|--|------------|
| 9.4 | External Bus Interface | 34 |
| 9.5 | Static Memory Controller | 35 |
| 9.6 | SDRAM Controller | 35 |
| 9.7 | Serial Peripheral Interface | 36 |
| 9.8 | Two-wire Interface | 36 |
| 9.9 | USART | 36 |
| 9.10 | Synchronous Serial Controller | 37 |
| 9.11 | Timer Counter | 37 |
| 9.12 | Multimedia Card Interface | 37 |
| 9.13 | USB | 37 |
| 9.14 | LCD Controller | 37 |
| 10. | ARM926EJ-S Processor | 38 |
| 10.1 | Overview | 38 |
| 10.2 | Block Diagram | 39 |
| 10.3 | ARM9EJ-S Processor | 39 |
| 10.4 | CP15 Coprocessor | 47 |
| 10.5 | Memory Management Unit (MMU) | 49 |
| 10.6 | Caches and Write Buffer | 50 |
| 10.7 | Tightly-Coupled Memory Interface | 52 |
| 10.8 | Bus Interface Unit | 52 |
| 11. | Debug and Test | 54 |
| 11.1 | Overview | 54 |
| 11.2 | Block Diagram | 54 |
| 11.3 | Application Examples | 55 |
| 11.4 | Debug and Test Pin Description | 56 |
| 11.5 | Functional Description | 57 |
| 12. | Boot Program | 76 |
| 12.1 | Description | 76 |
| 12.2 | Flow Diagram | 77 |
| 12.3 | Device Initialization | 78 |
| 12.4 | Valid Image Detection | 79 |
| 12.5 | Serial Flash Boot | 80 |
| 12.6 | DataFlash Boot Sequence | 81 |
| 12.7 | NAND Flash Boot | 82 |
| 12.8 | SD Card Boot | 82 |
| 12.9 | EEPROM Boot | 82 |
| 12.10 | SAM-BA Boot | 83 |
| 12.11 | Hardware and Software Constraints | 85 |
| 13. | Reset Controller (RSTC) | 87 |
| 13.1 | Overview | 87 |
| 13.2 | Embedded Characteristics | 87 |
| 13.3 | Block Diagram | 87 |
| 13.4 | Functional Description | 88 |
| 13.5 | Reset Controller (RSTC) User Interface | 97 |
| 14. | Real-time Timer (RTT) | 101 |
| 14.1 | Overview | 101 |
| 14.2 | Embedded Characteristics | 101 |

| | | |
|------------|--|------------|
| 14.3 | Block Diagram | 101 |
| 14.4 | Functional Description | 101 |
| 14.5 | Real-time Timer (RTT) User Interface | 103 |
| 15. | Periodic Interval Timer (PIT) | 108 |
| 15.1 | Overview | 108 |
| 15.2 | Embedded Characteristics | 108 |
| 15.3 | Block Diagram | 108 |
| 15.4 | Functional Description | 108 |
| 15.5 | Periodic Interval Timer (PIT) User Interface | 110 |
| 16. | Shutdown Controller (SHDWC) | 115 |
| 16.1 | Overview | 115 |
| 16.2 | Embedded Characteristics | 115 |
| 16.3 | Block Diagram | 115 |
| 16.4 | I/O Lines Description | 115 |
| 16.5 | Product Dependencies | 115 |
| 16.6 | Functional Description | 116 |
| 16.7 | Shutdown Controller (SHDWC) User Interface | 117 |
| 17. | General Purpose Backup Register (GPBR) | 121 |
| 17.1 | Overview | 121 |
| 17.2 | General Purpose Backup Registers (GPBR) User Interface | 121 |
| 18. | Bus Matrix | 123 |
| 18.1 | Overview | 123 |
| 18.2 | Memory Mapping | 123 |
| 18.3 | Special Bus Granting Techniques | 123 |
| 18.4 | Arbitration | 124 |
| 18.5 | Bus Matrix (MATRIX) User Interface | 125 |
| 19. | External Bus Interface (EBI) | 131 |
| 19.1 | Overview | 131 |
| 19.2 | Block Diagram | 132 |
| 19.3 | I/O Lines Description | 133 |
| 19.4 | Application Example | 134 |
| 19.5 | Product Dependencies | 137 |
| 19.6 | Functional Description | 138 |
| 19.7 | Implementation Examples | 145 |
| 20. | Static Memory Controller (SMC) | 154 |
| 20.1 | Overview | 154 |
| 20.2 | I/O Lines Description | 154 |
| 20.3 | Multiplexed Signals | 154 |
| 20.4 | Application Example | 155 |
| 20.5 | Product Dependencies | 155 |
| 20.6 | External Memory Mapping | 156 |
| 20.7 | Connection to External Devices | 157 |
| 20.8 | Standard Read and Write Protocols | 160 |
| 20.9 | Automatic Wait States | 168 |
| 20.10 | Data Float Wait States | 171 |
| 20.11 | External Wait | 176 |

| | | |
|------------|--|------------|
| 20.12 | Slow Clock Mode | 182 |
| 20.13 | Asynchronous Page Mode | 184 |
| 20.14 | Static Memory Controller (SMC) User Interface | 187 |
| 21. | SDRAM Controller (SDRAMC) | 193 |
| 21.1 | Overview | 193 |
| 21.2 | I/O Lines Description | 193 |
| 21.3 | Application Example | 194 |
| 21.4 | Product Dependencies | 196 |
| 21.5 | Functional Description | 198 |
| 21.6 | SDRAM Controller (SDRAMC) User Interface | 205 |
| 22. | Peripheral DMA Controller (PDC) | 216 |
| 22.1 | Overview | 216 |
| 22.2 | Block Diagram | 217 |
| 22.3 | Functional Description | 218 |
| 22.4 | Peripheral DMA Controller (PDC) User Interface | 220 |
| 23. | Clock Generator (CKGR) | 231 |
| 23.1 | Overview | 231 |
| 23.2 | Slow Clock Crystal Oscillator | 231 |
| 23.3 | Main Oscillator | 231 |
| 23.4 | Divider and PLL Block | 233 |
| 24. | Power Management Controller (PMC) | 235 |
| 24.1 | Overview | 235 |
| 24.2 | Master Clock Controller | 235 |
| 24.3 | Processor Clock Controller | 236 |
| 24.4 | USB Clock Controller | 236 |
| 24.5 | Peripheral Clock Controller | 236 |
| 24.6 | Programmable Clock Output Controller | 237 |
| 24.7 | Programming Sequence | 237 |
| 24.8 | Clock Switching Details | 241 |
| 24.9 | Power Management Controller (PMC) User Interface | 245 |
| 25. | Watchdog Timer (WDT) | 263 |
| 25.1 | Overview | 263 |
| 25.2 | Embedded Characteristics | 263 |
| 25.3 | Block Diagram | 263 |
| 25.4 | Functional Description | 264 |
| 25.5 | Watchdog Timer (WDT) User Interface | 266 |
| 26. | Advanced Interrupt Controller (AIC) | 271 |
| 26.1 | Overview | 271 |
| 26.2 | Block Diagram | 271 |
| 26.3 | Application Block Diagram | 271 |
| 26.4 | AIC Detailed Block Diagram | 272 |
| 26.5 | I/O Line Description | 272 |
| 26.6 | Product Dependencies | 272 |
| 26.7 | Functional Description | 273 |
| 26.8 | Advanced Interrupt Controller (AIC) User Interface | 282 |

| | |
|---|-----|
| 27. Debug Unit (DBGU) | 301 |
| 27.1 Overview | 301 |
| 27.2 Embedded Characteristics | 301 |
| 27.3 Block Diagram | 302 |
| 27.4 Product Dependencies | 303 |
| 27.5 UART Operations | 303 |
| 27.6 Debug Unit (DBGU) User Interface | 310 |
| 28. Peripheral Input/Output Controller (PIO) | 326 |
| 28.1 Overview | 326 |
| 28.2 Block Diagram | 327 |
| 28.3 Product Dependencies | 328 |
| 28.4 Functional Description | 329 |
| 28.5 I/O Lines Programming Example | 334 |
| 28.6 Parallel Input/Output Controller (PIO) User Interface | 335 |
| 29. Serial Peripheral Interface (SPI) | 366 |
| 29.1 Overview | 366 |
| 29.2 Block Diagram | 366 |
| 29.3 Application Block Diagram | 367 |
| 29.4 Signal Description | 367 |
| 29.5 Product Dependencies | 368 |
| 29.6 Functional Description | 368 |
| 29.7 Serial Peripheral Interface (SPI) User Interface | 377 |
| 30. Two Wire Interface (TWI) | 391 |
| 30.1 Overview | 391 |
| 30.2 Embedded Characteristics | 391 |
| 30.3 List of Abbreviations | 392 |
| 30.4 Block Diagram | 392 |
| 30.5 Application Block Diagram | 393 |
| 30.6 Product Dependencies | 393 |
| 30.7 Functional Description | 394 |
| 30.8 Master Mode | 394 |
| 30.9 Multi-master Mode | 406 |
| 30.10 Slave Mode | 409 |
| 30.11 Two-wire Interface (TWI) User Interface | 416 |
| 31. Universal Synchronous Asynchronous Receiver Transmitter (USART) | 431 |
| 31.1 Overview | 431 |
| 31.2 Block Diagram | 431 |
| 31.3 Application Block Diagram | 432 |
| 31.4 I/O Lines Description | 432 |
| 31.5 Product Dependencies | 432 |
| 31.6 Functional Description | 433 |
| 31.7 Universal Synchronous Asynchronous Receiver Transmitter (USART) User Interface | 456 |
| 32. Synchronous Serial Controller (SSC) | 475 |
| 32.1 Overview | 475 |
| 32.2 Block Diagram | 475 |
| 32.3 Application Block Diagram | 476 |
| 32.4 Pin Name List | 476 |

| | | |
|------------|--|------------|
| 32.5 | Product Dependencies | 476 |
| 32.6 | Functional Description | 477 |
| 32.7 | SSC Application Examples | 487 |
| 32.8 | Synchronous Serial Controller (SSC) User Interface | 489 |
| 33. | Timer Counter (TC) | 514 |
| 33.1 | Overview | 514 |
| 33.2 | Embedded Characteristics | 514 |
| 33.3 | Block Diagram | 515 |
| 33.4 | Pin Name List | 515 |
| 33.5 | Product Dependencies | 516 |
| 33.6 | Functional Description | 516 |
| 33.7 | Timer Counter (TC) User Interface | 528 |
| 34. | MultiMedia Card Interface (MCI) | 547 |
| 34.1 | Overview | 547 |
| 34.2 | Embedded Characteristics | 547 |
| 34.3 | Block Diagram | 548 |
| 34.4 | Application Block Diagram | 548 |
| 34.5 | Pin Name List | 549 |
| 34.6 | Product Dependencies | 549 |
| 34.7 | Bus Topology | 550 |
| 34.8 | MultiMedia Card Operations | 551 |
| 34.9 | SD Card Operations | 560 |
| 34.10 | MultiMedia Card Interface (MCI) User Interface | 561 |
| 35. | USB Host Port (UHP) | 581 |
| 35.1 | Overview | 581 |
| 35.2 | Embedded Characteristics | 581 |
| 35.3 | Block Diagram | 582 |
| 35.4 | Product Dependencies | 583 |
| 35.5 | Functional Description | 584 |
| 35.6 | Typical Connection | 585 |
| 36. | USB Device Port (UDP) | 586 |
| 36.1 | Overview | 586 |
| 36.2 | Embedded Characteristics | 586 |
| 36.3 | Block Diagram | 587 |
| 36.4 | Product Dependencies | 587 |
| 36.5 | Typical Connection | 588 |
| 36.6 | Functional Description | 589 |
| 36.7 | USB Device Port (UDP) User Interface | 602 |
| 37. | LCD Controller (LCDC) | 621 |
| 37.1 | Overview | 621 |
| 37.2 | Block Diagram | 622 |
| 37.3 | I/O Lines Description | 623 |
| 37.4 | Product Dependencies | 623 |
| 37.5 | Functional Description | 623 |
| 37.6 | Interrupts | 641 |
| 37.7 | Configuration Sequence | 641 |
| 37.8 | Double-buffer Technique | 642 |

| | | |
|------------|---|------------|
| 37.9 | Register Configuration Guide | 643 |
| 37.10 | LCD Controller (LCDC) User Interface | 644 |
| 38. | Electrical Characteristics | 676 |
| 38.1 | Absolute Maximum Ratings | 676 |
| 38.2 | DC Characteristics | 676 |
| 38.3 | Power Consumption | 677 |
| 38.4 | Clock Characteristics | 679 |
| 38.5 | Crystal Oscillator Characteristics | 680 |
| 38.6 | USB Transceiver Characteristics | 683 |
| 38.7 | Core Power Supply POR Characteristics | 683 |
| 38.8 | EBI Timings | 684 |
| 38.9 | SDRAMC Timings | 688 |
| 38.10 | Peripheral Timings | 691 |
| 39. | Mechanical Characteristics | 696 |
| 39.1 | Package Drawings | 696 |
| 39.2 | Soldering Profile | 697 |
| 40. | Marking | 698 |
| 41. | Ordering Information | 699 |
| 42. | Errata | 700 |
| 42.1 | SAM9261 Errata - Revision A Parts | 700 |
| 42.2 | SAM9261 Errata - Revision B Parts | 712 |
| 43. | Revision History | 723 |
| | Table of Contents | 742 |



Atmel® | Enabling Unlimited Possibilities®



Atmel Corporation 1600 Technology Drive, San Jose, CA 95110 USA T: (+1)(408) 441.0311 F: (+1)(408) 436.4200 | www.atmel.com

© 2016 Atmel Corporation. / Rev.: Atmel-60620-ATARM-SAM9261-Datasheet_21-Jun-16.

Atmel®, Atmel logo and combinations thereof, Enabling Unlimited Possibilities®, and others are registered trademarks or trademarks of Atmel Corporation in U.S. and other countries. ARM®, ARM Connected® logo, and others are the registered trademarks or trademarks of ARM Ltd. Other terms and product names may be trademarks of others.

DISCLAIMER: The information in this document is provided in connection with Atmel products. No license, express or implied, by estoppel or otherwise, to any intellectual property right is granted by this document or in connection with the sale of Atmel products. EXCEPT AS SET FORTH IN THE ATMEL TERMS AND CONDITIONS OF SALES LOCATED ON THE ATMEL WEBSITE, ATMEL ASSUMES NO LIABILITY WHATSOEVER AND DISCLAIMS ANY EXPRESS, IMPLIED OR STATUTORY WARRANTY RELATING TO ITS PRODUCTS INCLUDING, BUT NOT LIMITED TO, THE IMPLIED WARRANTY OF MERCHANTABILITY, FITNESS FOR A PARTICULAR PURPOSE, OR NON-INFRINGEMENT. IN NO EVENT SHALL ATMEL BE LIABLE FOR ANY DIRECT, INDIRECT, CONSEQUENTIAL, PUNITIVE, SPECIAL OR INCIDENTAL DAMAGES (INCLUDING, WITHOUT LIMITATION, DAMAGES FOR LOSS AND PROFITS, BUSINESS INTERRUPTION, OR LOSS OF INFORMATION) ARISING OUT OF THE USE OR INABILITY TO USE THIS DOCUMENT, EVEN IF ATMEL HAS BEEN ADVISED OF THE POSSIBILITY OF SUCH DAMAGES. Atmel makes no representations or warranties with respect to the accuracy or completeness of the contents of this document and reserves the right to make changes to specifications and products descriptions at any time without notice. Atmel does not make any commitment to update the information contained herein. Unless specifically provided otherwise, Atmel products are not suitable for, and shall not be used in, automotive applications. Atmel products are not intended, authorized, or warranted for use as components in applications intended to support or sustain life.

SAFETY-CRITICAL, MILITARY, AND AUTOMOTIVE APPLICATIONS DISCLAIMER: Atmel products are not designed for and will not be used in connection with any applications where the failure of such products would reasonably be expected to result in significant personal injury or death ("Safety-Critical Applications") without an Atmel officer's specific written consent. Safety-Critical Applications include, without limitation, life support devices and systems, equipment or systems for the operation of nuclear facilities and weapons systems. Atmel products are not designed nor intended for use in military or aerospace applications or environments unless specifically designated by Atmel as military-grade. Atmel products are not designed nor intended for use in automotive applications unless specifically designated by Atmel as automotive-grade.

Mouser Electronics

Authorized Distributor

Click to View Pricing, Inventory, Delivery & Lifecycle Information:

[Microchip:](#)

[AT91SAM9261B-CU](#) [AT91SAM9261B-CU-999](#)

Компания «Океан Электроники» предлагает заключение долгосрочных отношений при поставках импортных электронных компонентов на взаимовыгодных условиях!

Наши преимущества:

- Поставка оригинальных импортных электронных компонентов напрямую с производств Америки, Европы и Азии, а так же с крупнейших складов мира;
- Широкая линейка поставок активных и пассивных импортных электронных компонентов (более 30 млн. наименований);
- Поставка сложных, дефицитных, либо снятых с производства позиций;
- Оперативные сроки поставки под заказ (от 5 рабочих дней);
- Экспресс доставка в любую точку России;
- Помощь Конструкторского Отдела и консультации квалифицированных инженеров;
- Техническая поддержка проекта, помощь в подборе аналогов, поставка прототипов;
- Поставка электронных компонентов под контролем ВП;
- Система менеджмента качества сертифицирована по Международному стандарту ISO 9001;
- При необходимости вся продукция военного и аэрокосмического назначения проходит испытания и сертификацию в лаборатории (по согласованию с заказчиком);
- Поставка специализированных компонентов военного и аэрокосмического уровня качества (Xilinx, Altera, Analog Devices, Intersil, Interpoint, Microsemi, Actel, Aeroflex, Peregrine, VPT, Syfer, Eurofarad, Texas Instruments, MS Kennedy, Miteq, Cobham, E2V, MA-COM, Hittite, Mini-Circuits, General Dynamics и др.);

Компания «Океан Электроники» является официальным дистрибьютором и эксклюзивным представителем в России одного из крупнейших производителей разъемов военного и аэрокосмического назначения «**JONHON**», а так же официальным дистрибьютором и эксклюзивным представителем в России производителя высокотехнологичных и надежных решений для передачи СВЧ сигналов «**FORSTAR**».



JONHON

«**JONHON**» (основан в 1970 г.)

Разъемы специального, военного и аэрокосмического назначения:

(Применяются в военной, авиационной, аэрокосмической, морской, железнодорожной, горно- и нефтедобывающей отраслях промышленности)

«**FORSTAR**» (основан в 1998 г.)

ВЧ соединители, коаксиальные кабели,
кабельные сборки и микроволновые компоненты:

(Применяются в телекоммуникациях гражданского и специального назначения, в средствах связи, РЛС, а так же военной, авиационной и аэрокосмической отраслях промышленности).



Телефон: 8 (812) 309-75-97 (многоканальный)

Факс: 8 (812) 320-03-32

Электронная почта: ocean@oceanchips.ru

Web: <http://oceanchips.ru/>

Адрес: 198099, г. Санкт-Петербург, ул. Калинина, д. 2, корп. 4, лит. А