

**ZHT431**  
**ADJUSTABLE PRECISION ZENER SHUNT REGULATOR**

**Description**

The ZHT431 is a three terminal adjustable shunt regulator offering excellent temperature stability and output current handling capability up to 100mA. The device offers extended operating temperature range working from -55 to +125°C.

The output voltage may be set to any chosen voltage between 2.5 and 20 volts by selection of two external divider resistors.

The devices can be used as a replacement for zener diodes in many applications requiring an improvement in zener performance.

**Features**

- Surface mount SOT23 package
- 0.5%, 1% and 2% tolerance
- Maximum temperature coefficient 67ppm/°C
- Temperature compensated for operation over the full temperature range
- Programmable output voltage
- 50µA to 100mA current sink capability
- Low output noise
- Available in “Green” Molding Compound (See page 7)
- Wide temperature range -55 to +125°C

**Applications**

- Series and shunt regulator
- Voltage monitor
- Over voltage / under voltage protection
- Switch mode power supplies

**Pin Assignments**

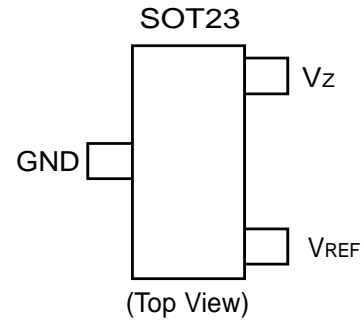

**Typical Application Circuit**

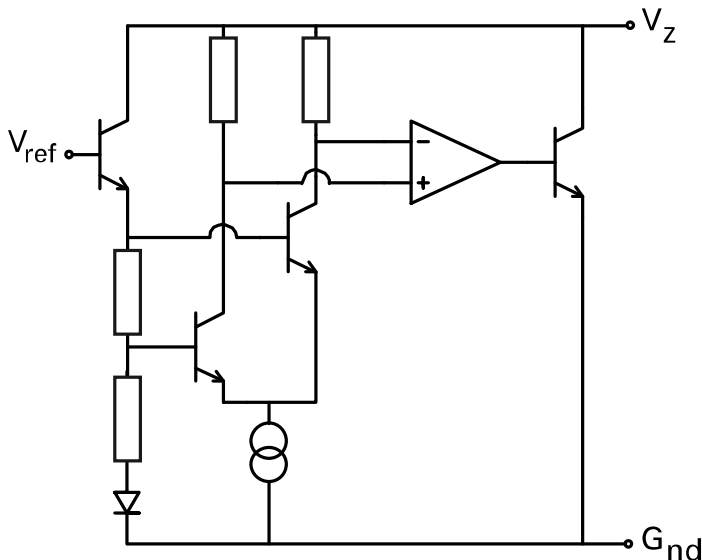

**Absolute Maximum Ratings** (Voltages to GND Unless Otherwise Stated)

Parameter	Rating	Unit
Cathode Voltage (V <sub>Z</sub> )	20	V
Cathode Current	150	mA
Operating Temperature	-55 to 125	°C
Storage Temperature	-55 to 150	°C
Power Dissipation (T <sub>amb</sub> = 25°C, T <sub>JMAX</sub> = 150°C)	330	mW

**Recommended Operating Conditions**

Parameter	Min	Max	Units
Cathode Voltage V <sub>REF</sub>	-	20	V
Cathode Current	0.05	100	mA

**Electrical Characteristics** (Test conditions unless otherwise specified: T<sub>amb</sub> = 25°C)

Symbol	Parameter	Values			Units	Conditions
		Min.	Typ.	Max.		
V <sub>REF</sub>	Reference Voltage 2% 1% 0.5%	2.45 2.475 2.4875	2.50 2.50 2.50	2.55 2.525 2.5125	V	I <sub>L</sub> =10mA (Fig.1), V <sub>Z</sub> =V <sub>REF</sub>
V <sub>DEV</sub>	Deviation of reference input voltage over temperature		10	30	mV	I <sub>L</sub> =10mA, V <sub>Z</sub> =V <sub>REF</sub> T <sub>amb</sub> =full range (Fig1)
$\frac{\Delta V_{REF}}{\Delta V_Z}$	Ratio of the change in reference voltage to the change in cathode voltage		-1.85	-2.7	mV/V	V <sub>Z</sub> from V <sub>REF</sub> to 10V I <sub>Z</sub> =10mA (Fig.2)
				-1.0	-2.	mV/V
I <sub>REF</sub>	Reference input current		0.12	1.0	µA	R1=10k, R2=O/C, I <sub>L</sub> =10mA (Fig.2)
ΔI <sub>REF</sub>	Deviation of reference input current over temperature		0.04	0.2	µA	R1=10k, R2=O/C, I <sub>L</sub> =10mA T <sub>amb</sub> =full range (Fig.2)
I <sub>Zmin</sub>	Minimum cathode current for regulation		35	50	µA	V <sub>Z</sub> =V <sub>REF</sub> (Fig.1)
I <sub>Zoff</sub>	Off-state current			0.1	µA	V <sub>Z</sub> =20V, V <sub>REF</sub> =0V(Fig.3)
R <sub>Z</sub>	Dynamic output impedance			0.75	V	V <sub>Z</sub> =V <sub>REF</sub> (Fig.1), f=0Hz, I <sub>C</sub> =1mA to 100mA

Deviation of reference input voltage, V<sub>DEV</sub>, is defined as the maximum variation of the reference input voltage over the full temperature range.

The average temperature coefficient of the reference input voltage, V<sub>REF</sub> is defined as:

$$V_{REF} \left( \frac{ppm}{^{\circ}C} \right) = \frac{V_{DEV} \times 1000000}{V_{REF}(T1 - T2)}$$

The dynamic output impedance, R<sub>Z</sub>, is defined as:

$$R_Z = \frac{\Delta V_Z}{\Delta I_Z}$$

When the device is programmed with two external resistors, R1 and R2, (fig 2) , the dynamic output impedance of the overall circuit, R', is defined as:

$$R' = R_Z \left( 1 + \frac{R1}{R2} \right)$$

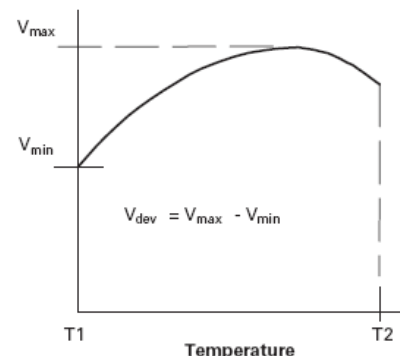

**Typical Operating Conditions**

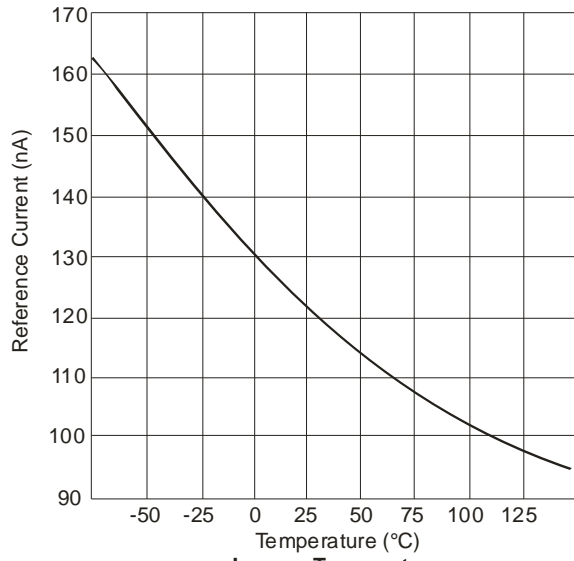

**$I_{REF}$  vs. Temperature**

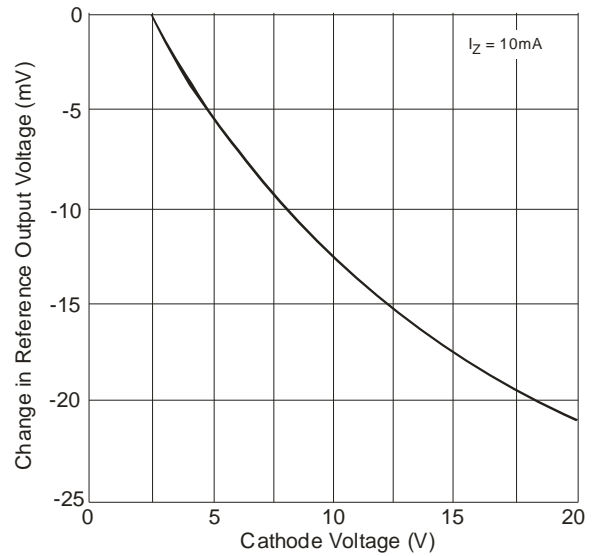

**Change in  $V_{REF}$  vs. Cathode Voltage**

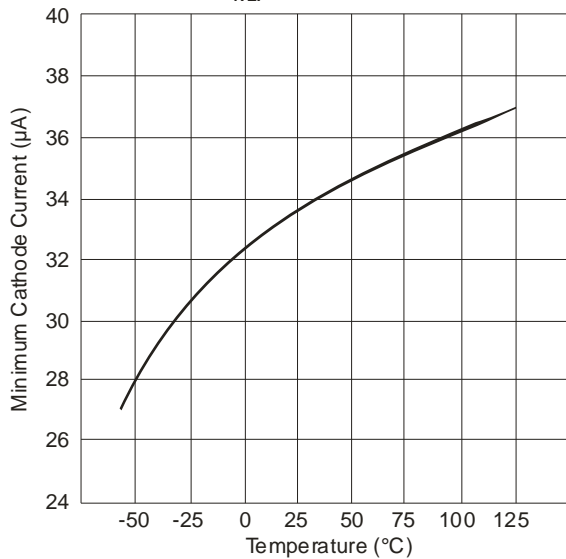

**$I_{ZMIN}$  vs. Temperature**

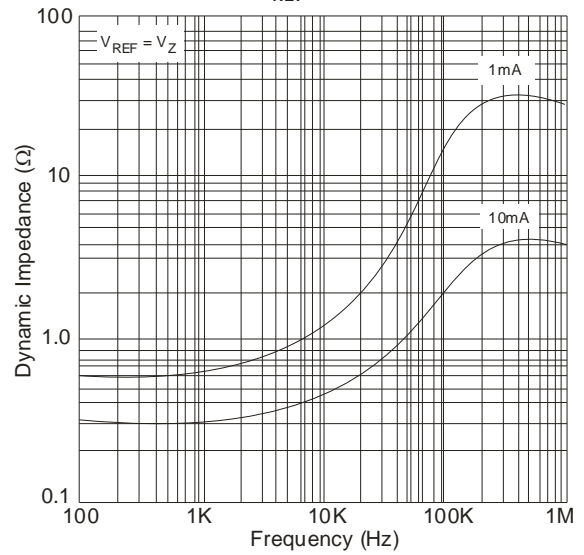

**Dynamic Impedance vs. Frequency**

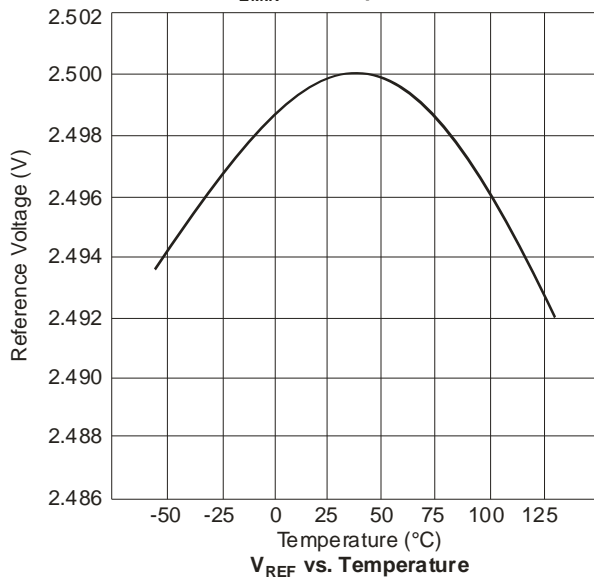

**$V_{REF}$  vs. Temperature**

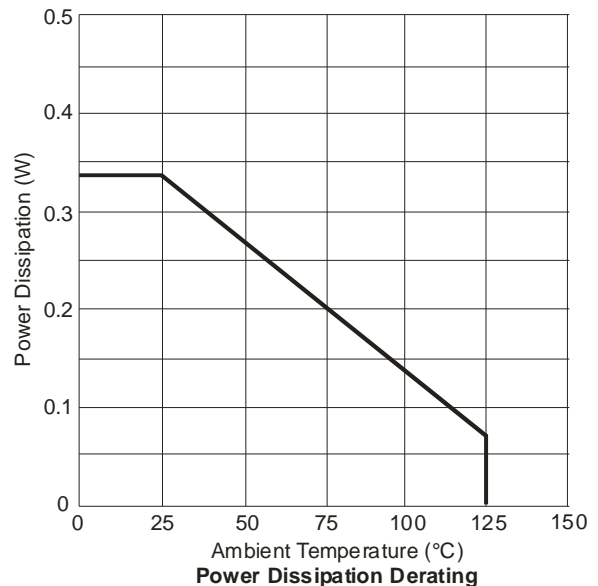

**Power Dissipation Derating**

**Typical Operating Conditions (Cont.)**

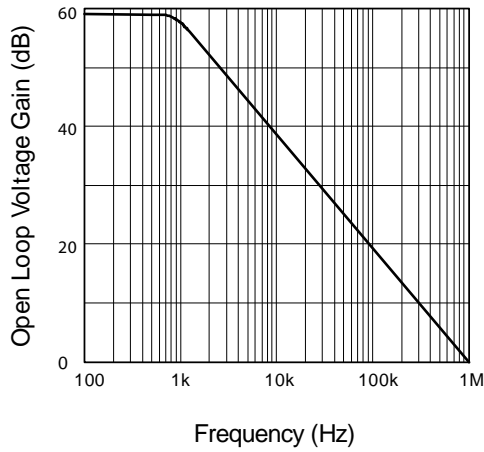

Gain v Frequency

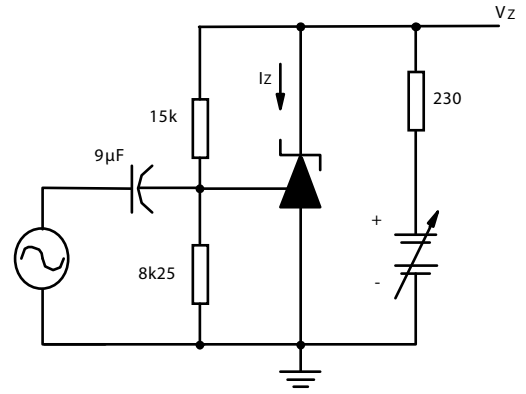

$I_Z = 10\text{mA}$ ,  $T_A = 25^\circ\text{C}$

Test Circuit for Open Loop Voltage Gain

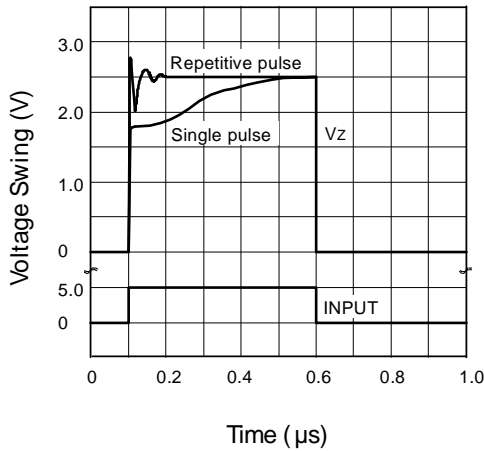

Pulse Response

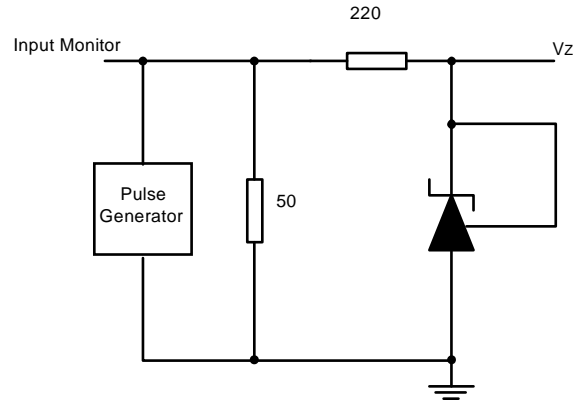

$T_A = 25^\circ\text{C}$

Test Circuit for Pulse Response

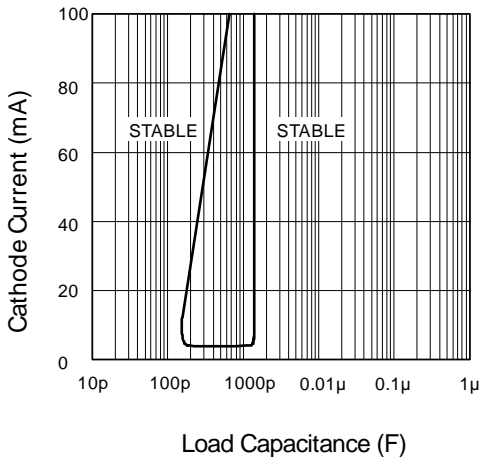

Stability Boundary Conditions

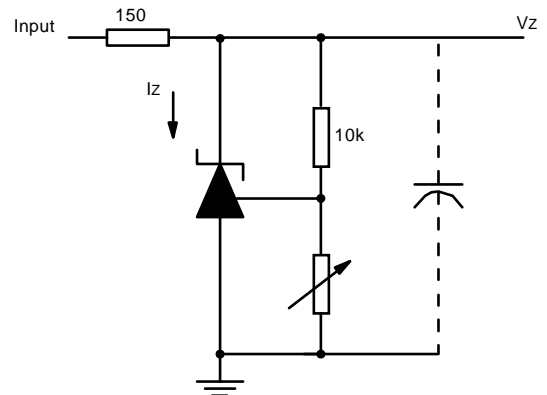

$V_{ref} < V_Z < 20$ ,  $I_Z = 10\text{mA}$ ,  $T_A = 25^\circ\text{C}$

Test Circuit for Stability Boundary Conditions

**DC Test Circuits**

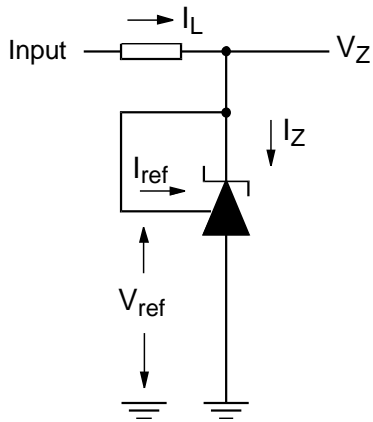

Fig 1 - Test circuit for  $V_Z = V_{ref}$

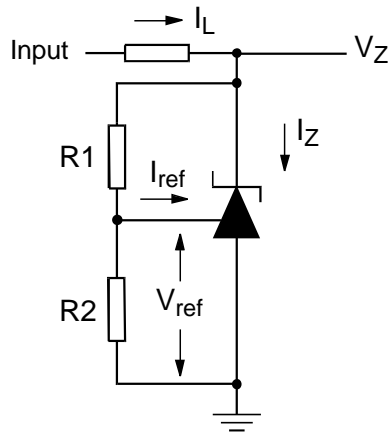

Fig 2 - Test circuit for  $V_Z > V_{ref}$

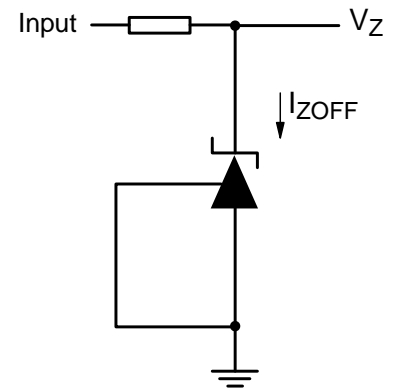
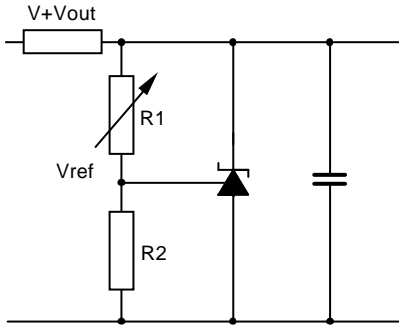

Fig 3 - Test circuit for Off state current†

**Application Circuits**



$$V_{out} = \left( 1 + \frac{R1}{R2} \right) V_{ref}$$

Shunt regulator

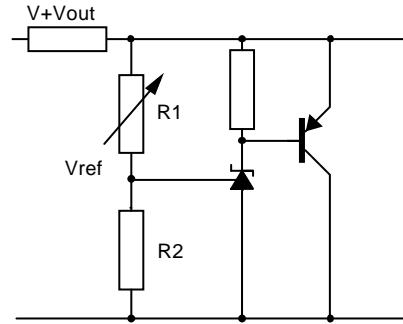

$$V_{out} = \left( 1 + \frac{R1}{R2} \right) V_{ref}$$

Higher current shunt regulator

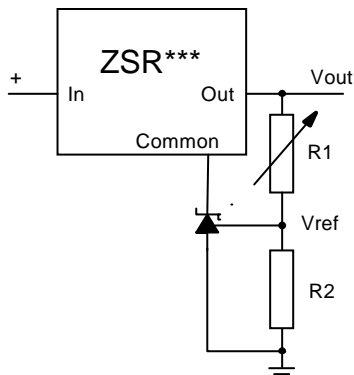

$$V_{out\_MIN} = V_{ref} + V_{reg}$$

$$V_{out} = \left( 1 + \frac{R1}{R2} \right) V_{ref}$$

Output control of a three terminal fixed regulator

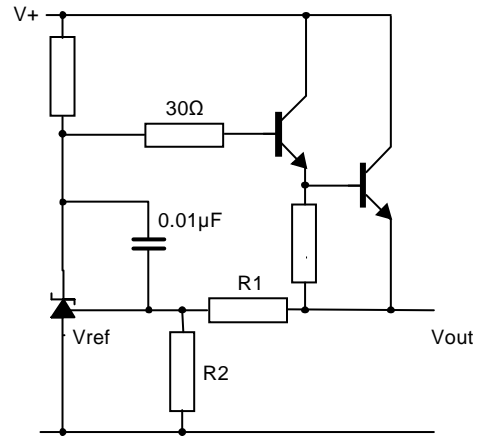

$$V_{out} = \left( 1 + \frac{R1}{R2} \right) V_{ref}$$

Series regulator

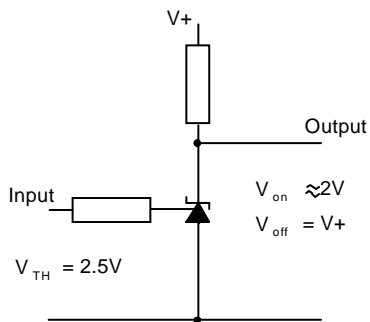

Single supply comparator with temperature compensated threshold

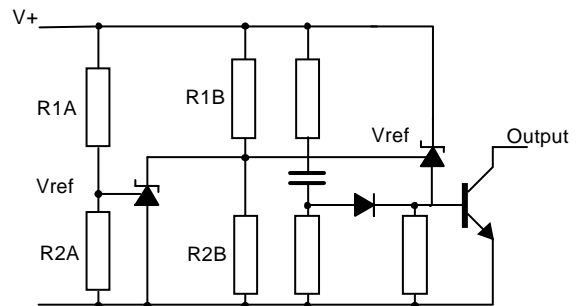

$$\text{Low limit} = \left( 1 + \frac{R1B}{R2B} \right) V_{ref}$$

$$\text{High limit} = \left( 1 + \frac{R1A}{R2A} \right) V_{ref}$$

Over voltage / under voltage protection circuit

**Ordering Information**

Ordering Reference	Tolerance (%)	Package	Part Mark	Status	Reel Size (inches)	Quantity per reel	Tape Width
ZHT431F01TA <sup>1</sup>	1	SOT23	43C	Active	7	3000	8mm
ZHT431F01-7 <sup>2</sup>	1	SOT23	43C	Active	7	3000	8mm
ZHT431FM TA <sup>1</sup>	0.5	SOT23	43P	Active	7	3000	8mm
ZHT431F02TA <sup>1</sup>	2	SOT23	43D	Active	7	3000	8mm

Notes: 1. A 'Green' molding compound is used from date code 1010. For further details, refer to [http://www.diodes.com/quality/lead\\_free.html](http://www.diodes.com/quality/lead_free.html)  
2. All date codes of the '-7' option use 'Green' molding compound.

**Package Outline Dimensions**

**SOT23**

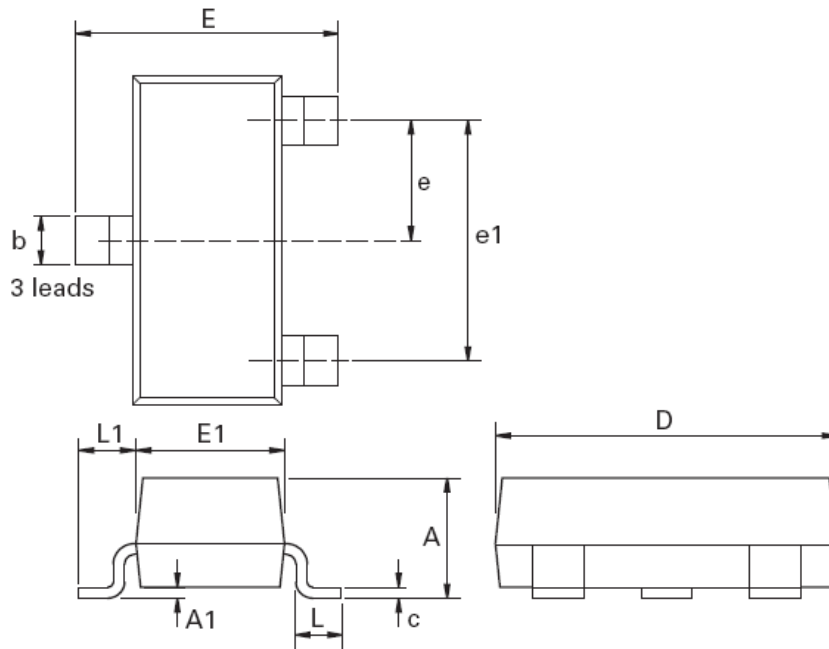

Dim.	Millimeters		Inches		Dim.	Millimeters		Inches	
	Min.	Max.	Min.	Max.		Min.	Max.	Min.	Max.
A	-	1.12	-	0.044	e1	1.90 NOM		0.075 NOM	
A1	0.01	0.10	0.0004	0.004	E	2.10	2.64	0.083	0.104
b	0.30	0.50	0.012	0.020	E1	1.20	1.40	0.047	0.055
c	0.085	0.20	0.003	0.008	L	0.25	0.60	0.0098	0.0236
D	2.80	3.04	0.110	0.120	L1	0.45	0.62	0.018	0.024
e	0.95	NOM	0.037	NOM	-	-	-	-	-

**Note:** Controlling dimensions are in millimeters. Approximate dimensions are provided in inches

#### IMPORTANT NOTICE

DIODES INCORPORATED MAKES NO WARRANTY OF ANY KIND, EXPRESS OR IMPLIED, WITH REGARDS TO THIS DOCUMENT, INCLUDING, BUT NOT LIMITED TO, THE IMPLIED WARRANTIES OF MERCHANTABILITY AND FITNESS FOR A PARTICULAR PURPOSE (AND THEIR EQUIVALENTS UNDER THE LAWS OF ANY JURISDICTION).

Diodes Incorporated and its subsidiaries reserve the right to make modifications, enhancements, improvements, corrections or other changes without further notice to this document and any product described herein. Diodes Incorporated does not assume any liability arising out of the application or use of this document or any product described herein; neither does Diodes Incorporated convey any license under its patent or trademark rights, nor the rights of others. Any Customer or user of this document or products described herein in such applications shall assume all risks of such use and will agree to hold Diodes Incorporated and all the companies whose products are represented on Diodes Incorporated website, harmless against all damages.

Diodes Incorporated does not warrant or accept any liability whatsoever in respect of any products purchased through unauthorized sales channel.

Should Customers purchase or use Diodes Incorporated products for any unintended or unauthorized application, Customers shall indemnify and hold Diodes Incorporated and its representatives harmless against all claims, damages, expenses, and attorney fees arising out of, directly or indirectly, any claim of personal injury or death associated with such unintended or unauthorized application.

Products described herein may be covered by one or more United States, international or foreign patents pending. Product names and markings noted herein may also be covered by one or more United States, international or foreign trademarks.

#### LIFE SUPPORT

Diodes Incorporated products are specifically not authorized for use as critical components in life support devices or systems without the express written approval of the Chief Executive Officer of Diodes Incorporated. As used herein:

A. Life support devices or systems are devices or systems which:

1. are intended to implant into the body, or
2. support or sustain life and whose failure to perform when properly used in accordance with instructions for use provided in the labeling can be reasonably expected to result in significant injury to the user.

B. A critical component is any component in a life support device or system whose failure to perform can be reasonably expected to cause the failure of the life support device or to affect its safety or effectiveness.

Customers represent that they have all necessary expertise in the safety and regulatory ramifications of their life support devices or systems, and acknowledge and agree that they are solely responsible for all legal, regulatory and safety-related requirements concerning their products and any use of Diodes Incorporated products in such safety-critical, life support devices or systems, notwithstanding any devices- or systems-related information or support that may be provided by Diodes Incorporated. Further, Customers must fully indemnify Diodes Incorporated and its representatives against any damages arising out of the use of Diodes Incorporated products in such safety-critical, life support devices or systems.

Copyright © 2010, Diodes Incorporated

[www.diodes.com](http://www.diodes.com)



Компания «Океан Электроники» предлагает заключение долгосрочных отношений при поставках импортных электронных компонентов на взаимовыгодных условиях!

Наши преимущества:

- Поставка оригинальных импортных электронных компонентов напрямую с производств Америки, Европы и Азии, а так же с крупнейших складов мира;
- Широкая линейка поставок активных и пассивных импортных электронных компонентов (более 30 млн. наименований);
- Поставка сложных, дефицитных, либо снятых с производства позиций;
- Оперативные сроки поставки под заказ (от 5 рабочих дней);
- Экспресс доставка в любую точку России;
- Помощь Конструкторского Отдела и консультации квалифицированных инженеров;
- Техническая поддержка проекта, помощь в подборе аналогов, поставка прототипов;
- Поставка электронных компонентов под контролем ВП;
- Система менеджмента качества сертифицирована по Международному стандарту ISO 9001;
- При необходимости вся продукция военного и аэрокосмического назначения проходит испытания и сертификацию в лаборатории (по согласованию с заказчиком);
- Поставка специализированных компонентов военного и аэрокосмического уровня качества (Xilinx, Altera, Analog Devices, Intersil, Interpoint, Microsemi, Actel, Aeroflex, Peregrine, VPT, Syfer, Eurofarad, Texas Instruments, MS Kennedy, Miteq, Cobham, E2V, MA-COM, Hittite, Mini-Circuits, General Dynamics и др.);

Компания «Океан Электроники» является официальным дистрибьютором и эксклюзивным представителем в России одного из крупнейших производителей разъемов военного и аэрокосмического назначения «JONHON», а так же официальным дистрибьютором и эксклюзивным представителем в России производителя высокотехнологичных и надежных решений для передачи СВЧ сигналов «FORSTAR».



## JONHON

«JONHON» (основан в 1970 г.)

Разъемы специального, военного и аэрокосмического назначения:

(Применяются в военной, авиационной, аэрокосмической, морской, железнодорожной, горно- и нефтедобывающей отраслях промышленности)

«FORSTAR» (основан в 1998 г.)

ВЧ соединители, коаксиальные кабели, кабельные сборки и микроволновые компоненты:

(Применяются в телекоммуникациях гражданского и специального назначения, в средствах связи, РЛС, а так же военной, авиационной и аэрокосмической отраслях промышленности).



Телефон: 8 (812) 309-75-97 (многоканальный)

Факс: 8 (812) 320-03-32

Электронная почта: [ocean@oceanchips.ru](mailto:ocean@oceanchips.ru)

Web: <http://oceanchips.ru/>

Адрес: 198099, г. Санкт-Петербург, ул. Калинина, д. 2, корп. 4, лит. А