



DATA SHEET

SKY66013-11: 700 to 800 MHz, +19 dBm Linear Power Amplifier

Applications

- Residential femtocells
- WCDMA, Bands 12, 13, 14, 17
- Small cells

Features

- Small signal gain: 27.5 dB
- ACLR at P_{OUT} = +19 dBm: -51 dBc
- PA on/off control
- I/O impedance internally matched to 50 Ω
- Single DC supply: 3.3 V to 4.6 V
- Minimal number of external components required
- Small footprint MCM (10-pin, 3 x 3 mm) package (MSL3, 260 °C per JEDEC J-STD-020)



Skyworks Green™ products are compliant with all applicable legislation and are halogen-free. For additional information, refer to *Skyworks Definition of Green™*, document number SQ04-0074.

Description

The SKY66013-11 linear Power Amplifier (PA) is a fully matched surface mount module developed for WCDMA applications operating from 700 to 800 MHz. The device meets the stringent spectral linearity requirements of WCDMA femtocell applications with high power-added efficiency. An integrated directional coupler eliminates the need for any external coupler.

The GaAs MMIC contains all active amplifier circuitry, which includes input and interstage matching circuits. An output match into a 50 Ω load, realized off-chip within the module package, optimizes efficiency and power performance.

The SKY66013-11 is manufactured with Skyworks InGaP GaAs HBT process, which provides for all positive voltage DC supply operation and maintains high efficiency and good linearity. The primary bias to the device can be supplied directly from any suitable power supply with an output of 4.2 V. Power down is achieved by setting the VEN pin to 0 V. No external supply side switch is needed since typical “off” leakage is a few microamps with full primary voltage supplied from the main power supply.

The SKY66013-11 is packaged in a 10-pin, 3 x 3 mm Multi-Chip Module (MCM), which allows for a highly manufacturable low-cost solution.

The 10-pin MCM package and pinout are shown in Figure 1. A functional block diagram of the SKY66013-11 is shown in Figure 2. Signal pin assignments and functional pin descriptions are provided in Table 1.

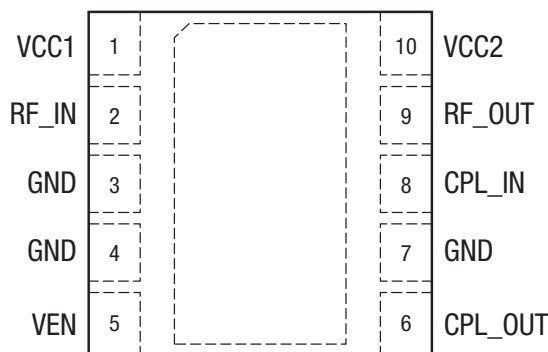

S2992

Figure 1. SKY66013-11 Pinout – 10-Pin MCM (Top View)

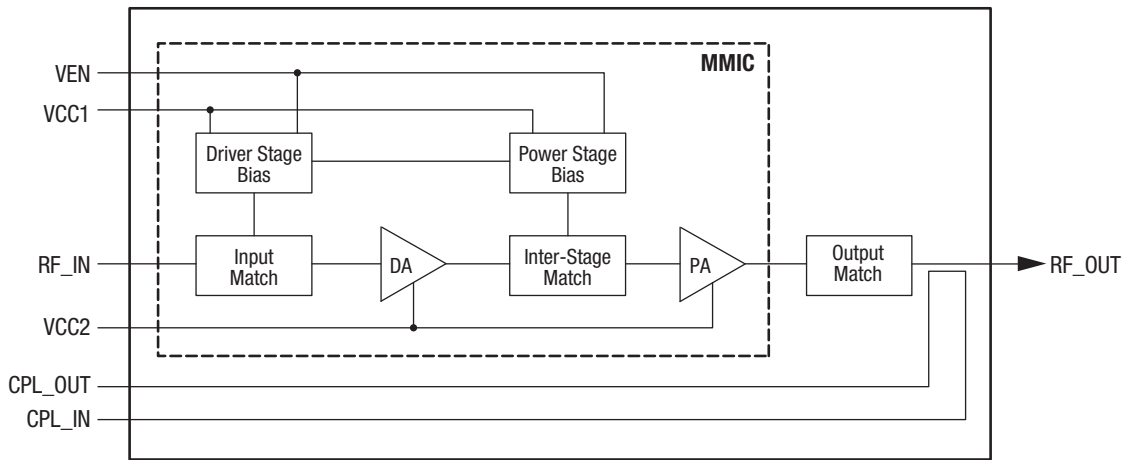

S2993

Figure 2. SKY66013-11 Linear PA Block Diagram

Table 1. SKY66013-11 Signal Descriptions

Pin	Name	Description	Pin	Name	Description
1	VCC1	Input stage supply voltage	6	CPL_OUT	RF coupler output
2	RF_IN	RF input port	7	GND	Ground
3	GND	Ground	8	CPL_IN	RF coupler input
4	GND	Ground	9	RF_OUT	RF output port
5	VEN	Enable	10	VCC2	Output stage supply voltage

Technical Description

The SKY66013-11 PA contains all of the needed RF matching and DC biasing circuits. The device is a two-stage, HBT InGaP device optimized for high linearity and power efficiency. These features make the device suitable for wideband digital applications where PA linearity and power consumption are of critical importance (e.g., small cell and infrastructure applications).

The device is designed for standard WCDMA modulated signals. Under these stringent test conditions, the device exhibits excellent spectral purity and power efficiency.

Electrical and Mechanical Specifications

The absolute maximum ratings of the SKY66013-11 are provided in Table 2. The recommended operating conditions are specified in Table 3 and electrical specifications are provided in Table 4.

Table 2. SKY66013-11 Absolute Maximum Ratings (Note 1)

Parameter	Symbol	Minimum	Maximum	Units
Supply voltage (VCC1, VCC2)	VCC	0	+4.6	V
Total supply current	ICC		700	mA
Logic control input voltage (VEN)	VCTL	-0.5	3.1	V
Case operating temperature (Note 2)	Tc	-40	+85	°C
Storage temperature	TSTG	-55	+150	°C
Junction temperature	TJ		+150	°C
Thermal resistance	ΘJC		60	°C/W

Note 1: Exposure to maximum rating conditions for extended periods may reduce device reliability. There is no damage to device with only one parameter set at the limit and all other parameters set at or below their nominal value. Exceeding any of the limits listed here may result in permanent damage to the device.

Note 2: Case operating temperature (Tc) refers to the temperature of the bottom ground pad.

CAUTION: Although this device is designed to be as robust as possible, Electrostatic Discharge (ESD) can damage this device. This device must be protected at all times from ESD. Static charges may easily produce potentials of several kilovolts on the human body or equipment, which can discharge without detection. Industry-standard ESD precautions should be used at all times.

Table 3. SKY66013-11 Recommended Operating Conditions

Parameter	Symbol	Minimum	Typical	Maximum	Units
Frequency range	f	729		768	MHz
Supply voltage (VCC1, VCC2) (Note 1)	VCC	4.0	4.2	4.6	V
Logic control input voltage:					
Logic high	V _{IH}	1.35	1.80	3.10	V
Logic low	V _{IL}	0		0.5	V
PA enable current	I _{EN}			<1	mA
Case operating temperature	Tc	-20	+25	+85	°C

Note 1: Voltage levels measured at the pads of the package. The Evaluation Board supply voltage levels may be different. Refer to the Evaluation Board schematic diagram in this Data Sheet.

Table 4. SKY66013-11 Electrical Specifications (Note 1)
(VCC1 = VCC2 = +4.2 V, Tc = +25 °C, f = 746 MHz, Characteristic Impedance [Zo] = 50 Ω, VEN = “1,” Unless Otherwise Noted)

Parameter	Symbol	Test Condition	Min	Typical	Max	Units
Small signal gain	IS211	CW, PIN = -20 dBm	25.5	27.5		dB
Input return loss	IS111	CW, PIN = -20 dBm		-17		dB
Quiescent current	ICQ	No RF		45	55	mA
Operating current	ICC	CW, POUT = +19 dBm		110	120	mA
Power-down current	IPD	VEN = “0”		1	5	μA
3 rd order output intercept point	OIP3	Δf = 5 MHz		+40		dBm
Adjacent channel leakage ratio	ACLR5	@5 MHz offset, WCDMA test model 1, with 64 DPCH, POUT = +19 dBm		-51	-45	dBc
Error Vector Magnitude	EVM	POUT = +19 dBm		2	3	%
Harmonic suppression	2fo 3fo	CW, POUT = +19 dBm		-43 -60	-38 -54	dBc dBc
Stability (non-harmonic spurious)	VSWRSTABILITY	VSWR = 6:1 @ POUT = +19 dBm		-63		dBc
Maximum ruggedness input power	PIN_RUG	VSWR = 6:1		-7		dBm

Note 1: Performance is guaranteed only under the conditions listed in this Table. Both pins 6 and 8 (CPL_OUT and CPL_IN, respectively) should be terminated with 50 Ω.

Evaluation Board Description

The SKY66013-11 Evaluation Board is used to test the performance of the SKY66013-11 PA. A schematic diagram of the Evaluation Board is shown in Figure 3. An assembly drawing for the Evaluation Board is shown in Figure 4 and the layer detail is provided in Figure 5.

Package Dimensions

The PCB layout footprint for the SKY66013-11 is provided in Figure 6. Typical case markings are shown in Figure 7. Figure 8 shows the package dimensions for the 10-pin MCM, and Figure 9 provides the tape and reel dimensions.

Package and Handling Information

Since the device package is sensitive to moisture absorption, it is baked and vacuum packed before shipping. Instructions on the

shipping container label regarding exposure to moisture after the container seal is broken must be followed. Otherwise, problems related to moisture absorption may occur when the part is subjected to high temperature during solder assembly.

The SKY66013-11 is rated to Moisture Sensitivity Level 3 (MSL3) at 260 °C. It can be used for lead or lead-free soldering. For additional information, refer to the Skyworks Application Note, *PCB Design and SMT Assembly/Rework Guidelines for MCM-L Packages*, document number 101752.

Care must be taken when attaching this product, whether it is done manually or in a production solder reflow environment. Production quantities of this product are shipped in a standard tape and reel format.

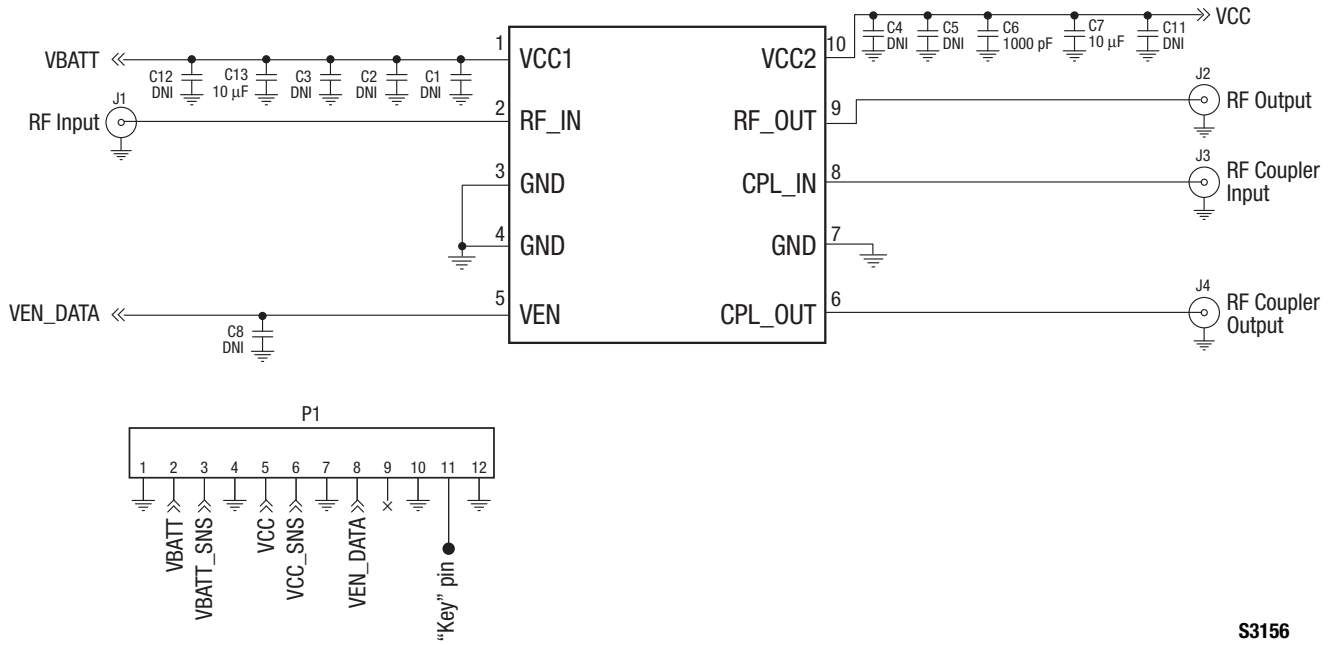

S3156

Figure 3. SKY66013-11 Evaluation Board Schematic

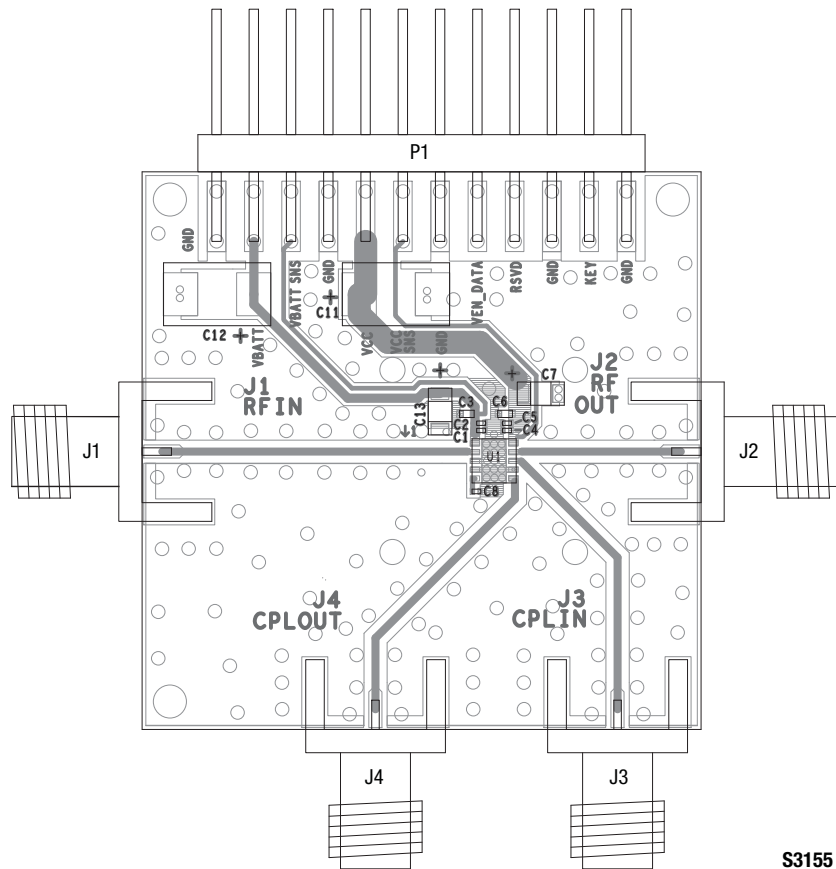

S3155

Figure 4. SKY66013-11 Evaluation Board Assembly Diagram

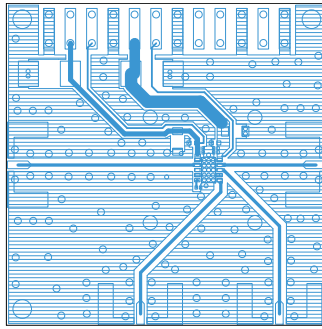

Layer 1: Top Metal

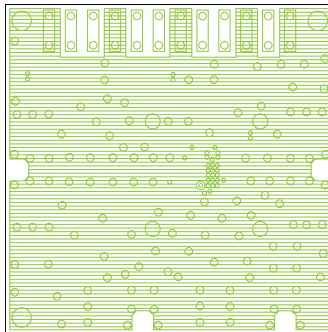

Layer 2: Ground

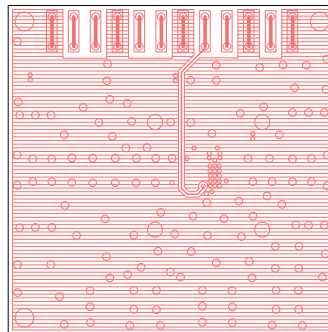

Layer 3: Ground

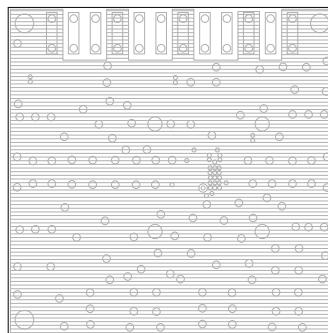

Layer 4: Bottom (Ground) Layer

S3157

Figure 5. SKY66013-11 Evaluation Board Layer Detail

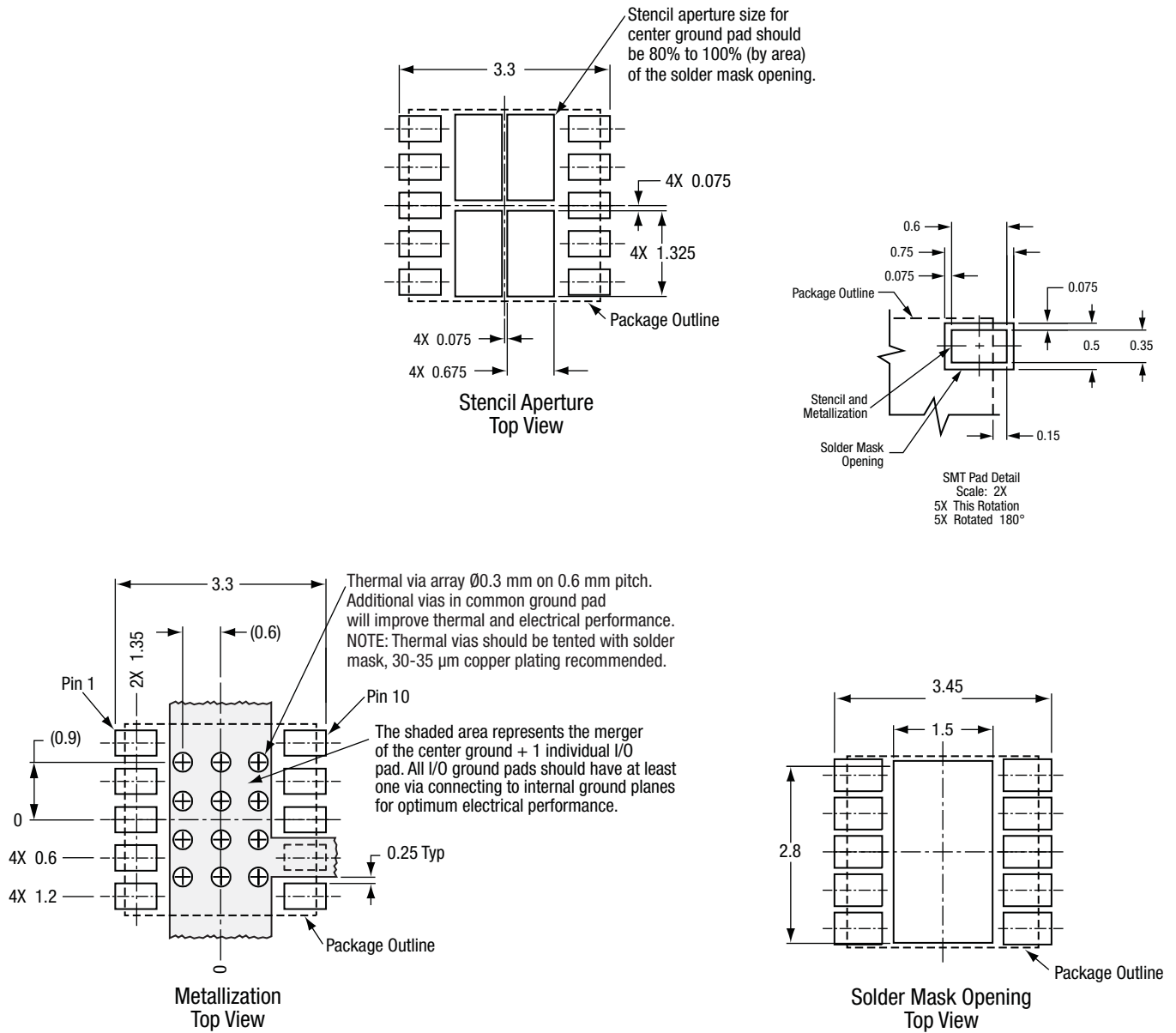

All dimensions are in millimeters

S2995

Figure 6. PCB Layout Footprint for the SKY66013-11 3 x 3 mm MCM

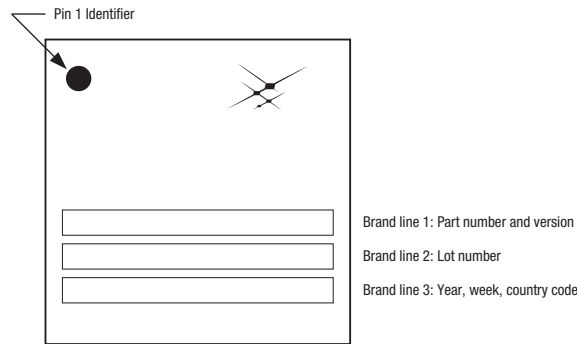
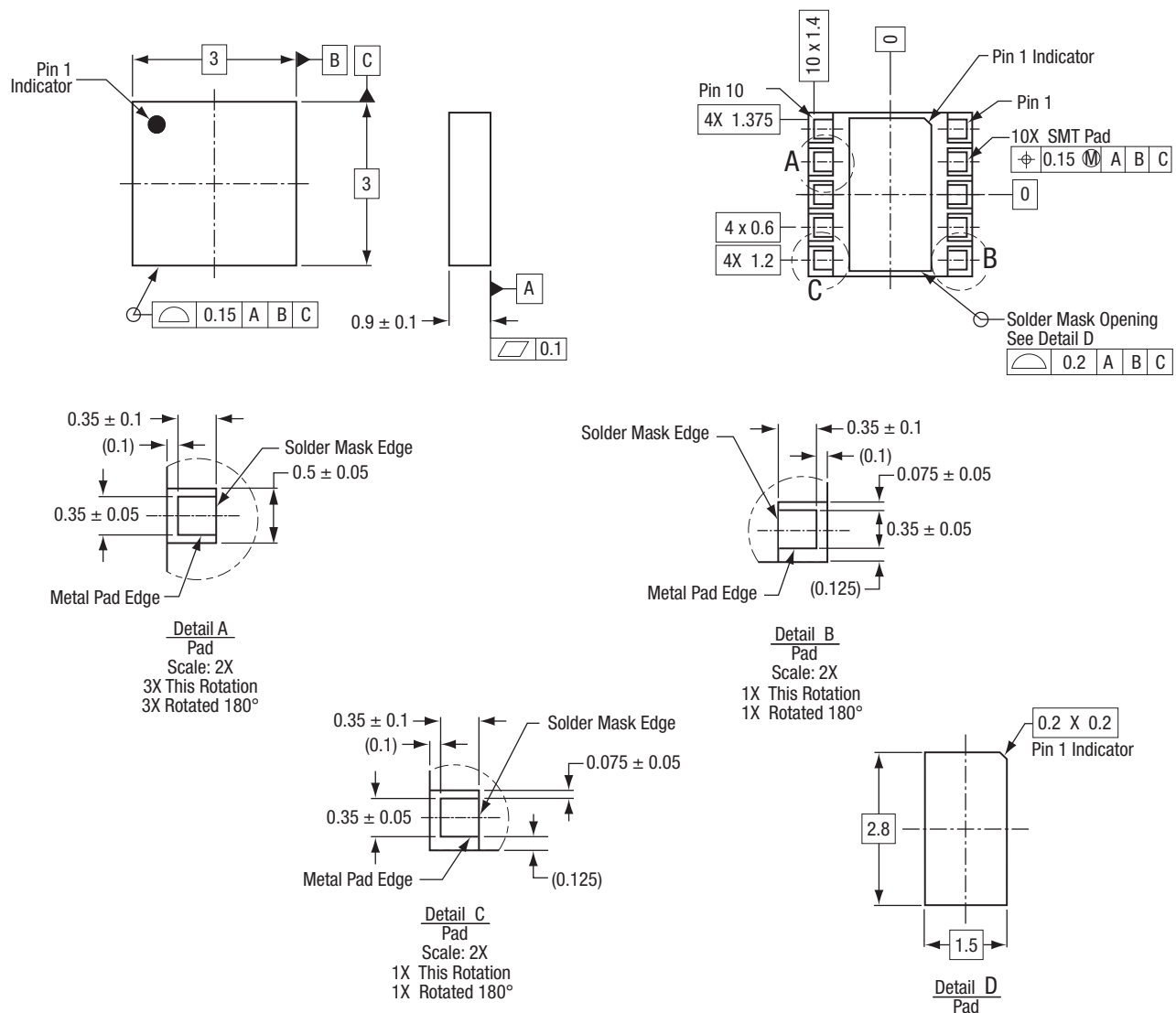

Figure 7. Typical Case Markings (Top View)



Dimensioning and Tolerancing in accordance with ASME Y14.5M-1994
 All dimensions are in millimeters.

S2991

Figure 8. SKY66013-11 10-Pin MCM Package Dimensions

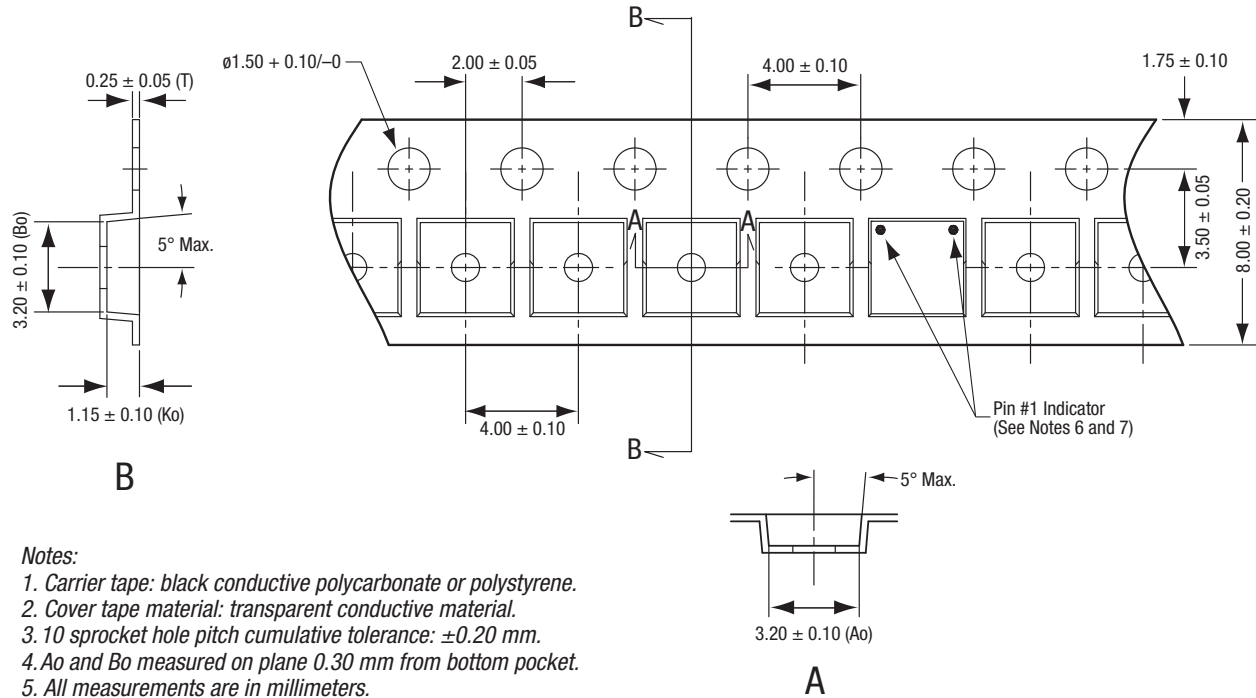

Notes:

1. Carrier tape: black conductive polycarbonate or polystyrene.
2. Cover tape material: transparent conductive material.
3. 10 sprocket hole pitch cumulative tolerance: ± 0.20 mm.
4. Ao and Bo measured on plane 0.30 mm from bottom pocket.
5. All measurements are in millimeters.
6. Pin 1 orientation is in top left corner for the following 3 x 3 mm products:
 SKY13420
 SKY13435
 SKY77729
7. Pin 1 orientation is in top right for all other 3 x 3 mm MCMs and RFLGA products.

S3581

Figure 9. SKY66013-11 Tape and Reel Dimensions

Ordering Information

Model Name	Manufacturing Part Number	Evaluation Board Part Number
SKY66013-11: 729 to 768 MHz, +19 dBm Linear PA	SKY66013-11	EN40-D605

Copyright © 2013-2014 Skyworks Solutions, Inc. All Rights Reserved.

Information in this document is provided in connection with Skyworks Solutions, Inc. (“Skyworks”) products or services. These materials, including the information contained herein, are provided by Skyworks as a service to its customers and may be used for informational purposes only by the customer. Skyworks assumes no responsibility for errors or omissions in these materials or the information contained herein. Skyworks may change its documentation, products, services, specifications or product descriptions at any time, without notice. Skyworks makes no commitment to update the materials or information and shall have no responsibility whatsoever for conflicts, incompatibilities, or other difficulties arising from any future changes.

No license, whether express, implied, by estoppel or otherwise, is granted to any intellectual property rights by this document. Skyworks assumes no liability for any materials, products or information provided hereunder, including the sale, distribution, reproduction or use of Skyworks products, information or materials, except as may be provided in Skyworks Terms and Conditions of Sale.

THE MATERIALS, PRODUCTS AND INFORMATION ARE PROVIDED “AS IS” WITHOUT WARRANTY OF ANY KIND, WHETHER EXPRESS, IMPLIED, STATUTORY, OR OTHERWISE, INCLUDING FITNESS FOR A PARTICULAR PURPOSE OR USE, MERCHANTABILITY, PERFORMANCE, QUALITY OR NON-INFRINGEMENT OF ANY INTELLECTUAL PROPERTY RIGHT; ALL SUCH WARRANTIES ARE HEREBY EXPRESSLY DISCLAIMED. SKYWORKS DOES NOT WARRANT THE ACCURACY OR COMPLETENESS OF THE INFORMATION, TEXT, GRAPHICS OR OTHER ITEMS CONTAINED WITHIN THESE MATERIALS. SKYWORKS SHALL NOT BE LIABLE FOR ANY DAMAGES, INCLUDING BUT NOT LIMITED TO ANY SPECIAL, INDIRECT, INCIDENTAL, STATUTORY, OR CONSEQUENTIAL DAMAGES, INCLUDING WITHOUT LIMITATION, LOST REVENUES OR LOST PROFITS THAT MAY RESULT FROM THE USE OF THE MATERIALS OR INFORMATION, WHETHER OR NOT THE RECIPIENT OF MATERIALS HAS BEEN ADVISED OF THE POSSIBILITY OF SUCH DAMAGE.

Skyworks products are not intended for use in medical, lifesaving or life-sustaining applications, or other equipment in which the failure of the Skyworks products could lead to personal injury, death, physical or environmental damage. Skyworks customers using or selling Skyworks products for use in such applications do so at their own risk and agree to fully indemnify Skyworks for any damages resulting from such improper use or sale.

Customers are responsible for their products and applications using Skyworks products, which may deviate from published specifications as a result of design defects, errors, or operation of products outside of published parameters or design specifications. Customers should include design and operating safeguards to minimize these and other risks. Skyworks assumes no liability for applications assistance, customer product design, or damage to any equipment resulting from the use of Skyworks products outside of stated published specifications or parameters.

Skyworks, the Skyworks symbol, Helios, and “Breakthrough Simplicity” are trademarks or registered trademarks of Skyworks Solutions, Inc., in the United States and other countries. Third-party brands and names are for identification purposes only, and are the property of their respective owners. Additional information, including relevant terms and conditions, posted at www.skyworksinc.com, are incorporated by reference.

Компания «Океан Электроники» предлагает заключение долгосрочных отношений при поставках импортных электронных компонентов на взаимовыгодных условиях!

Наши преимущества:

- Поставка оригинальных импортных электронных компонентов напрямую с производств Америки, Европы и Азии, а так же с крупнейших складов мира;
- Широкая линейка поставок активных и пассивных импортных электронных компонентов (более 30 млн. наименований);
- Поставка сложных, дефицитных, либо снятых с производства позиций;
- Оперативные сроки поставки под заказ (от 5 рабочих дней);
- Экспресс доставка в любую точку России;
- Помощь Конструкторского Отдела и консультации квалифицированных инженеров;
- Техническая поддержка проекта, помощь в подборе аналогов, поставка прототипов;
- Поставка электронных компонентов под контролем ВП;
- Система менеджмента качества сертифицирована по Международному стандарту ISO 9001;
- При необходимости вся продукция военного и аэрокосмического назначения проходит испытания и сертификацию в лаборатории (по согласованию с заказчиком);
- Поставка специализированных компонентов военного и аэрокосмического уровня качества (Xilinx, Altera, Analog Devices, Intersil, Interpoint, Microsemi, Actel, Aeroflex, Peregrine, VPT, Syfer, Eurofarad, Texas Instruments, MS Kennedy, Miteq, Cobham, E2V, MA-COM, Hittite, Mini-Circuits, General Dynamics и др.);

Компания «Океан Электроники» является официальным дистрибьютором и эксклюзивным представителем в России одного из крупнейших производителей разъемов военного и аэрокосмического назначения «JONHON», а так же официальным дистрибьютором и эксклюзивным представителем в России производителя высокотехнологичных и надежных решений для передачи СВЧ сигналов «FORSTAR».



JONHON

«JONHON» (основан в 1970 г.)

Разъемы специального, военного и аэрокосмического назначения:

(Применяются в военной, авиационной, аэрокосмической, морской, железнодорожной, горно- и нефтедобывающей отраслях промышленности)

«FORSTAR» (основан в 1998 г.)

ВЧ соединители, коаксиальные кабели,
кабельные сборки и микроволновые компоненты:

(Применяются в телекоммуникациях гражданского и специального назначения, в средствах связи, РЛС, а так же военной, авиационной и аэрокосмической отраслях промышленности).



Телефон: 8 (812) 309-75-97 (многоканальный)

Факс: 8 (812) 320-03-32

Электронная почта: ocean@oceanchips.ru

Web: <http://oceanchips.ru/>

Адрес: 198099, г. Санкт-Петербург, ул. Калинина, д. 2, корп. 4, лит. А