



USB3500



Hi-Speed USB Host, Device or OTG PHY With UTMI+ Interface

PRODUCT FEATURES

[Datasheet](#)

- USB-IF “Hi-Speed” certified to the Universal Serial Bus Specification Rev 2.0
- Interface compliant with the UTMI+ Specification, Revision 1.0.
- Includes full support for the optional On-The-Go (OTG) protocol detailed in the On-The-Go Supplement Revision 1.0a specification.
- Functional as a host, device or OTG PHY.
- Supports HS, FS, and LS data rates.
- Supports FS pre-amble for FS hubs with a LS device attached (UTMI+ Level 3)
- Supports HS SOF and LS keep alive pulse.
- Supports Host Negotiation Protocol (HNP) and Session Request protocol (SRP.)
- Internal comparators support OTG monitoring of VBUS levels.
- Low Latency Hi-Speed Receiver (43 Hi-Speed clocks Max)
- Internal 1.8 volt regulators allow operation from a single 3.3 volt supply
- Internal short circuit protection of ID, DP and DM lines to VBUS or ground.
- Integrated 24MHz Crystal Oscillator supports either crystal operation or 24MHz external clock input.
- Internal PLL for 480MHz Hi-Speed USB operation.
- Supports USB 2.0 and legacy USB 1.1 devices
- 55mA Unconfigured Current (typical) - ideal for bus powered applications.
- 83uA suspend current (typical) - ideal for battery powered applications.
- Full Commercial operating temperature range from 0C to +70C
- 56 Pin, QFN lead-free RoHS compliant package (8 x 8 x 0.90 mm height)

ORDER NUMBER:**USB3500-ABZJ FOR 56 PIN, QFN LEAD-FREE ROHS COMPLIANT PACKAGE**

80 ARKAY DRIVE, HAUPPAUGE, NY 11788 (631) 435-6000, FAX (631) 273-3123

Copyright © 2008 SMSC or its subsidiaries. All rights reserved.

Circuit diagrams and other information relating to SMSC products are included as a means of illustrating typical applications. Consequently, complete information sufficient for construction purposes is not necessarily given. Although the information has been checked and is believed to be accurate, no responsibility is assumed for inaccuracies. SMSC reserves the right to make changes to specifications and product descriptions at any time without notice. Contact your local SMSC sales office to obtain the latest specifications before placing your product order. The provision of this information does not convey to the purchaser of the described semiconductor devices any licenses under any patent rights or other intellectual property rights of SMSC or others. All sales are expressly conditional on your agreement to the terms and conditions of the most recently dated version of SMSC's standard Terms of Sale Agreement dated before the date of your order (the "Terms of Sale Agreement"). The product may contain design defects or errors known as anomalies which may cause the product's functions to deviate from published specifications. Anomaly sheets are available upon request. SMSC products are not designed, intended, authorized or warranted for use in any life support or other application where product failure could cause or contribute to personal injury or severe property damage. Any and all such uses without prior written approval of an Officer of SMSC and further testing and/or modification will be fully at the risk of the customer. Copies of this document or other SMSC literature, as well as the Terms of Sale Agreement, may be obtained by visiting SMSC's website at <http://www.smisc.com>. SMSC is a registered trademark of Standard Microsystems Corporation ("SMSC"). Product names and company names are the trademarks of their respective holders.

SMSC DISCLAIMS AND EXCLUDES ANY AND ALL WARRANTIES, INCLUDING WITHOUT LIMITATION ANY AND ALL IMPLIED WARRANTIES OF MERCHANTABILITY, FITNESS FOR A PARTICULAR PURPOSE, TITLE, AND AGAINST INFRINGEMENT AND THE LIKE, AND ANY AND ALL WARRANTIES ARISING FROM ANY COURSE OF DEALING OR USAGE OF TRADE. IN NO EVENT SHALL SMSC BE LIABLE FOR ANY DIRECT, INCIDENTAL, INDIRECT, SPECIAL, PUNITIVE, OR CONSEQUENTIAL DAMAGES; OR FOR LOST DATA, PROFITS, SAVINGS OR REVENUES OF ANY KIND; REGARDLESS OF THE FORM OF ACTION, WHETHER BASED ON CONTRACT; TORT; NEGLIGENCE OF SMSC OR OTHERS; STRICT LIABILITY; BREACH OF WARRANTY; OR OTHERWISE; WHETHER OR NOT ANY REMEDY OF BUYER IS HELD TO HAVE FAILED OF ITS ESSENTIAL PURPOSE, AND WHETHER OR NOT SMSC HAS BEEN ADVISED OF THE POSSIBILITY OF SUCH DAMAGES.



Datasheet

0.1 Reference Documents

- Universal Serial Bus Specification, Revision 2.0, April 27, 2000
- USB 2.0 Transceiver Macrocell Interface (UTMI) Specification, Version 1.02, May 27, 2000
- On-The-Go Supplement to the USB 2.0 Specification, Revision 1.0a, June 24, 2003
- UTMI+ Specification, Revision 1.0, February 2, 2004

Table of Contents

0.1	Reference Documents	3
<hr/>		
Chapter 1	General Description.....	7
1.1	Applications	8
<hr/>		
Chapter 2	Functional Overview	9
<hr/>		
Chapter 3	Pin Configuration and Pin Definitions.....	10
3.1	USB3500 Pin Locations	10
3.2	Pin Definitions.....	11
<hr/>		
Chapter 4	Limiting Values	15
<hr/>		
Chapter 5	Electrical Characteristics	16
<hr/>		
Chapter 6	Detailed Functional Description.....	21
6.1	8bit Bi-Directional Data Bus Operation.....	21
6.2	TX Logic	22
6.3	RX Logic.....	22
6.4	USB 2.0 Transceiver.....	25
6.4.1	High Speed and Full Speed Transceivers.....	25
6.4.2	Termination Resistors	25
6.4.3	Bias Generator	27
6.5	Crystal Oscillator and PLL	27
6.6	Internal Regulators and POR	27
6.6.1	Internal Regulators	27
6.6.2	Power On Reset (POR).....	28
6.7	USB On-The-Go (OTG) Module	28
6.7.1	ID Detection.....	29
6.7.2	VBUS Control	29
<hr/>		
Chapter 7	Application Notes.....	31
7.1	Linestate	31
7.2	OPMODES	32
7.3	Test Mode Support	32
7.4	SE0 Handling	33
7.5	Reset Detection	33
7.6	Suspend Detection	34
7.7	HS Detection Handshake	35
7.8	HS Detection Handshake – FS Downstream Facing Port	35
7.9	HS Detection Handshake – HS Downstream Facing Port	37
7.10	HS Detection Handshake – Suspend Timing	39
7.11	Assertion of Resume	40
7.12	Detection of Resume	41
7.13	HS Device Attach	41
7.14	USB Reset and Chirp	43
7.15	Application Diagram	45
<hr/>		
Chapter 8	Package Outline	46

List of Figures

Figure 1.1	Basic UTMI+ USB Device Block Diagram	7
Figure 1.2	UTMI+ Level 3 Support	8
Figure 2.1	USB3500 Block Diagram	9
Figure 3.1	USB3500 Pinout - Top View	10
Figure 6.1	FS CLK Relationship to Transmit Data and Control Signals	21
Figure 6.2	FS CLK Relationship to Receive Data and Control Signals	21
Figure 6.3	Transmit Timing for a Data Packet	22
Figure 6.4	Receive Timing for Data with Unstuffed Bits	23
Figure 6.5	Receive Timing for a Handshake Packet (no CRC)	24
Figure 6.6	Receive Timing for Setup Packet	24
Figure 6.7	Receive Timing for Data Packet (with CRC-16)	25
Figure 6.8	USB3500 On-the-Go Module	28
Figure 7.1	Reset Timing Behavior (HS Mode)	33
Figure 7.2	Suspend Timing Behavior (HS Mode)	34
Figure 7.3	HS Detection Handshake Timing Behavior (FS Mode)	36
Figure 7.4	Chirp K-J-K-J-K-J Sequence Detection State Diagram	37
Figure 7.5	HS Detection Handshake Timing Behavior (HS Mode)	38
Figure 7.6	HS Detection Handshake Timing Behavior from Suspend	39
Figure 7.7	Resume Timing Behavior (HS Mode)	40
Figure 7.8	Device Attach Behavior	42
Figure 7.9	USB Reset and Chirp	43
Figure 7.10	USB3500 Application Diagram (Top View)	45
Figure 8.1	USB3500-ABZJ 56 Pin QFN Package Outline, 8 x 8 x 0.9 mm Body (Lead Free)	46

List of Tables

Table 3.1	USB3500 Pin Definitions	11
Table 4.1	Maximum Guaranteed Ratings	15
Table 4.2	Recommended Operating Conditions	15
Table 4.3	Recommended External Clock Conditions	15
Table 5.1	DC Electrical Characteristics: Supply Pins (Note 1)	16
Table 5.2	Electrical Characteristics: CLKOUT Start-Up	16
Table 5.3	DC Electrical Characteristics: Logic Pins.	16
Table 5.4	DC Electrical Characteristics: Analog I/O Pins (DP/DM)	17
Table 5.5	Dynamic Characteristics: Analog I/O Pins (DP/DM)	18
Table 5.6	Dynamic Characteristics: Digital UTMI Pins	19
Table 5.7	OTG Electrical Characteristics.	19
Table 5.8	Regulator Output Voltages	20
Table 6.1	DP/DM termination vs. Signaling Mode.	26
Table 6.2	IdGnd vs. USB Cable Type	29
Table 7.1	Device Linestate States (DPPD & DMPD = 0)	31
Table 7.2	Host Linestate States (DPPD & DMPD = 1)	31
Table 7.3	Operational Modes	32
Table 7.4	USB 2.0 Test Modes	32
Table 7.5	Reset Timing Values (HS Mode)	33
Table 7.6	Suspend Timing Values (HS Mode)	34
Table 7.7	HS Detection Handshake Timing Values (FS Mode).	36
Table 7.8	Reset Timing Values	38
Table 7.9	HS Detection Handshake Timing Values from Suspend	40
Table 7.10	Resume Timing Values (HS Mode)	41
Table 7.11	Attach and Reset Timing Values	42
Table 8.1	56 Terminal QFN Package Parameters.	46

Chapter 1 General Description

The USB3500 is a stand-alone Hi-Speed USB Physical Layer Transceiver (PHY). The USB3500 uses a UTMI+ interface to connect to an SOC or FPGA or custom ASIC. The USB3500 provides a flexible alternative to integrating the analog PHY block for new designs.

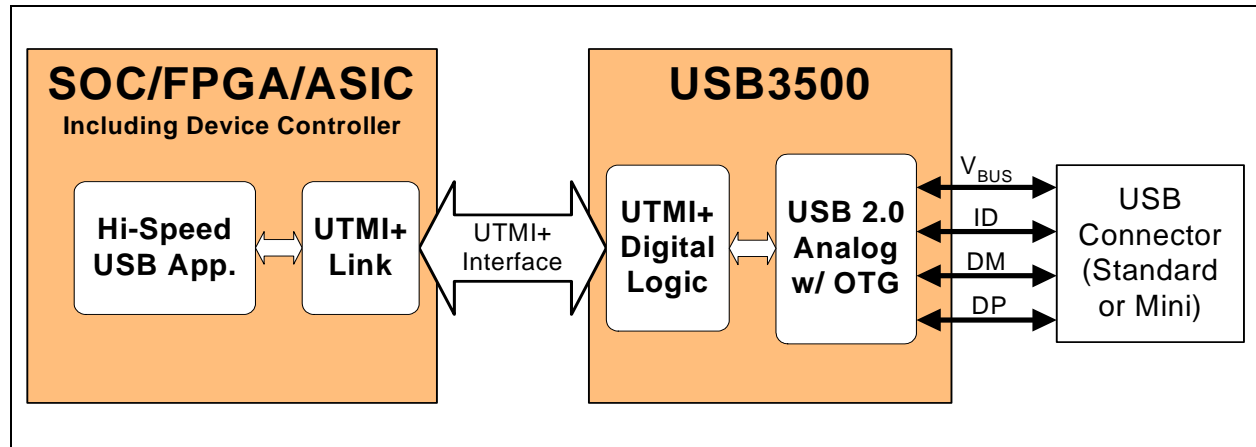

Figure 1.1 Basic UTMI+ USB Device Block Diagram

The USB3500 provides a fully compliant USB 2.0 interface, and supports High-Speed (HS), Full-Speed (FS), and Low-Speed (LS) USB. The USB3500 supports all levels of the UTMI+ specification as shown in [Figure 1.2](#).

The USB3500 can also, as an option, fully support the On-the-Go (OTG) protocol defined in the On-The-Go Supplement to the USB 2.0 Specification. On-the-Go allows the Link to dynamically configure the USB3500 as host or peripheral configured dynamically by software. For example, a cell phone may connect to a computer as a peripheral to exchange address information or connect to a printer as a host to print pictures. Finally the OTG enabled device can connect to another OTG enabled device to exchange information. All this is supported using a single low profile Mini-AB USB connector.

Designs not needing OTG can ignore the OTG feature set.

The USB3500 uses SMSC's advanced proprietary technology to minimize power dissipation, resulting in maximized battery life in portable applications.

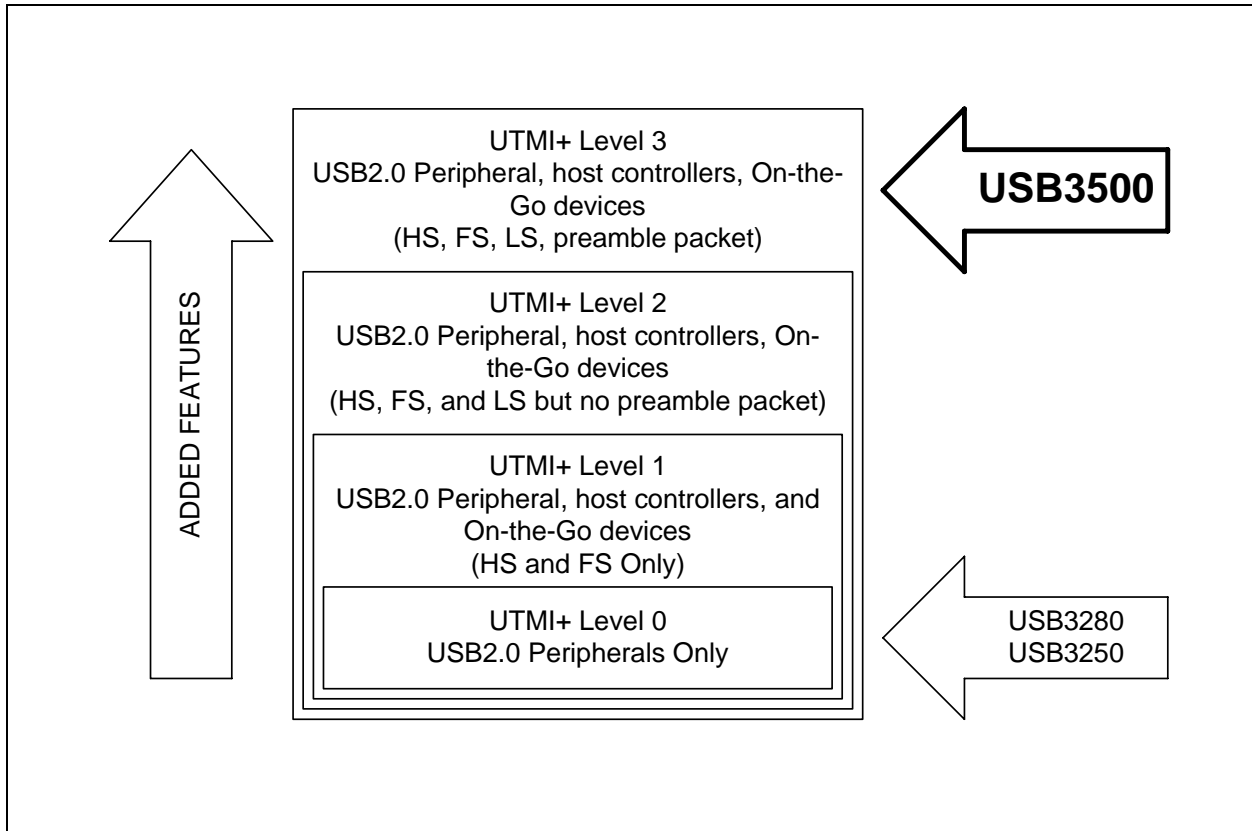

Figure 1.2 UTMI+ Level 3 Support

1.1 Applications

The USB3500 is targeted for any application where a hi-speed USB connection is desired.

The USB3500 is well suited for:

- Cell Phones
- MP3 Players
- Scanners
- Printers
- External Hard Drives
- Still and Video Cameras
- Portable Media Players
- Entertainment Devices

Chapter 2 Functional Overview

The USB3500 is a highly integrated USB transceiver system. It contains a complete USB 2.0 PHY with the UTMI+ industry standard interface to support fast time to market for a USB controller. The USB3500 is composed of the functional blocks shown in [Figure 2.1](#) below.

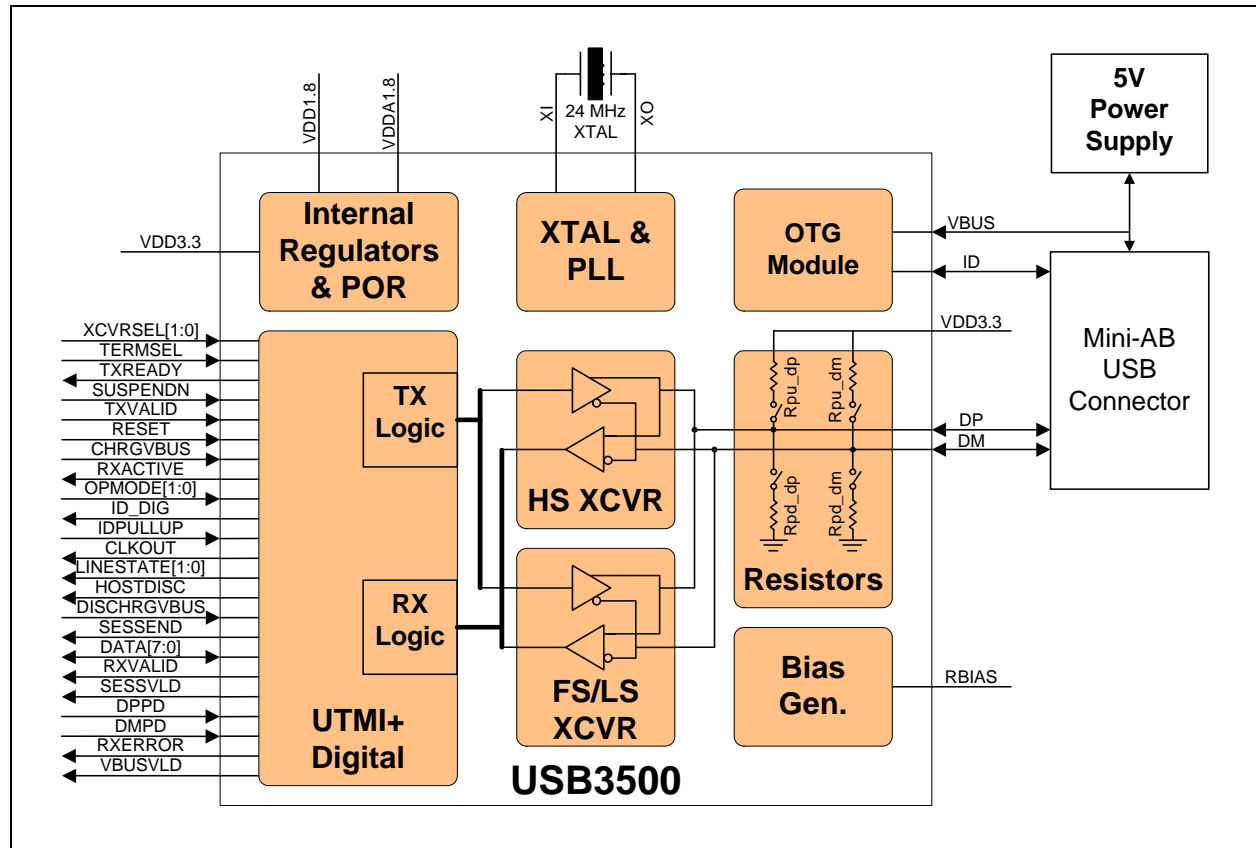

Figure 2.1 USB3500 Block Diagram

Chapter 3 Pin Configuration and Pin Definitions

The USB3500 is offered in a 56 pin QFN package. The pin definitions and locations are documented below.

3.1 USB3500 Pin Locations

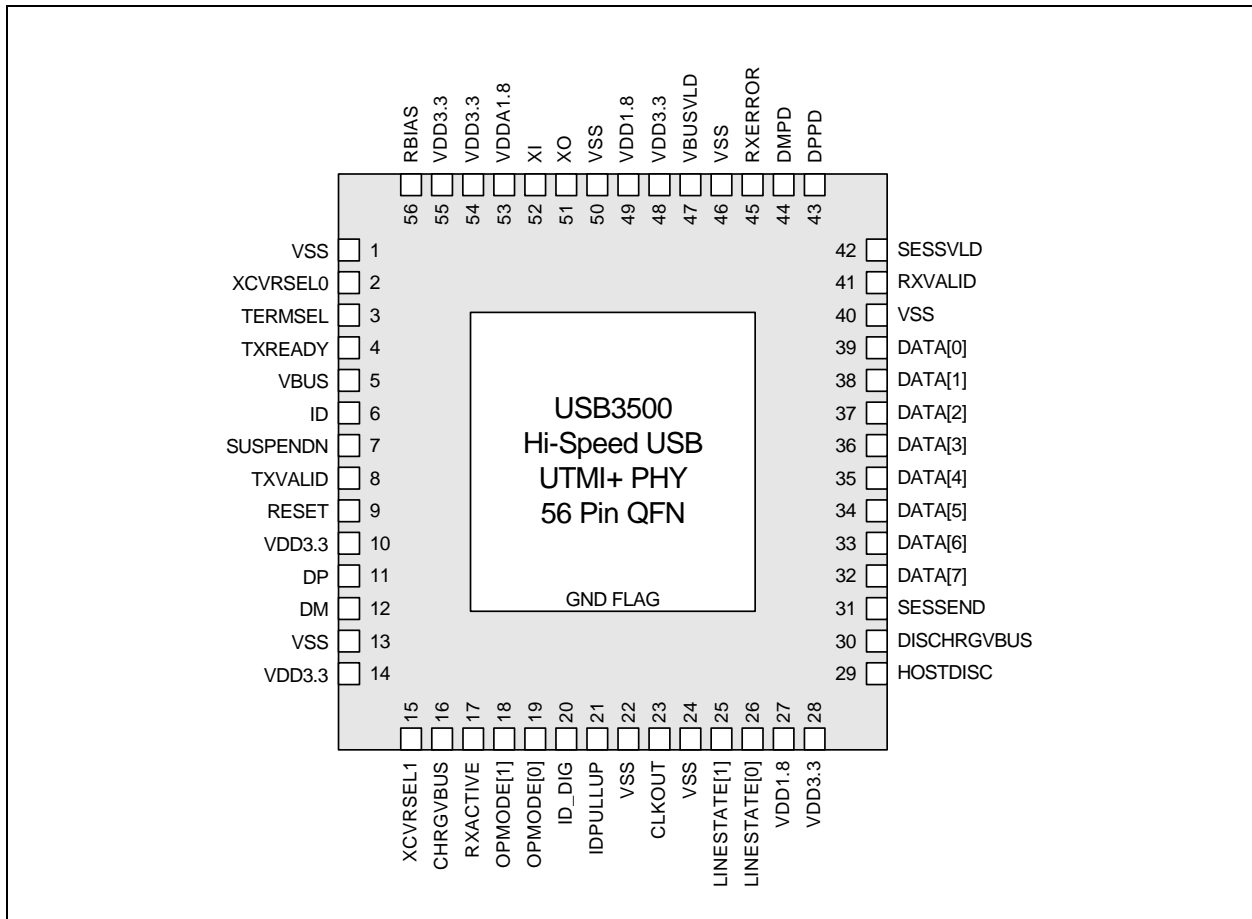

Figure 3.1 USB3500 Pinout - Top View

The flag of the QFN package must be connected to ground with a via array.

3.2 Pin Definitions

Table 3.1 USB3500 Pin Definitions

PIN	NAME	DIRECTION, TYPE	ACTIVE LEVEL	DESCRIPTION
1	VSS	Ground	N/A	PHY ground.
2	XCVRSEL[0]	Input	N/A	Transceiver Select. These signals select between the FS and HS transceivers: Transceiver select. 00: HS 01: FS 10: LS 11: LS data, FS rise/fall times
3	TERMSEL	Input	N/A	Termination Select. This signal selects between the FS and HS terminations: 0: HS termination enabled 1: FS termination enabled
4	TXREADY	Output	High	Transmit Data Ready. If TXVALID is asserted, the Link must always have data available for clocking into the TX Holding Register on the rising edge of CLKOUT. TXREADY is an acknowledgement to the Link that the transceiver has clocked the data from the bus and is ready for the next transfer on the bus. If TXVALID is negated, TXREADY can be ignored by the Link.
5	VBUS	I/O, Analog	N/A	VBUS pin of the USB cable.
6	ID	Input, Analog	N/A	ID pin of the USB cable.
7	SUSPENDN	Input	Low	Suspend. Places the transceiver in a mode that draws minimal power from supplies. In host mode, R _{PU} is removed during suspend. In device mode, R _{PD} is controlled by TERMSEL. In suspend mode the clocks are off. 0: PHY in suspend mode 1: PHY in normal operation
8	TXVALID	Input	High	Transmit Valid. Indicates that the DATA bus is valid for transmit. The assertion of TXVALID initiates the transmission of SYNC on the USB bus. The negation of TXVALID initiates EOP on the USB. Control inputs (OPMODE[1:0], TERMSEL, XCVERSEL) must not be changed on the de-assertion or assertion of TXVALID.
9	RESET	Input	High	Reset. Reset all state machines. After coming out of reset, must wait 5 rising edges of clock before asserting TXValid for transmit. Assertion of Reset: May be asynchronous to CLKOUT De-assertion of Reset: Must be synchronous to CLKOUT
10	VDD3.3	N/A	N/A	3.3V PHY Supply. Provides power for USB 2.0 Transceiver, UTMI+ Digital, Digital I/O, and Regulators.
11	DP	I/O, Analog	N/A	D+ pin of the USB cable.

Table 3.1 USB3500 Pin Definitions (continued)

PIN	NAME	DIRECTION, TYPE	ACTIVE LEVEL	DESCRIPTION															
12	DM	I/O, Analog	N/A	D- pin of the USB cable.															
13	VSS	Ground	N/A	PHY ground.															
14	VDD3.3	N/A	N/A	3.3V PHY Supply.															
15	XCVRSEL[1]	Input	N/A	Transceiver Select. These signals select between the FS and HS transceivers: Transceiver select. 00: HS 01: FS 10: LS 11: LS data, FS rise/fall times															
16	CHRGVBUS	Input	High	Charge VBUS through a resistor to VDD3.3. 0: do not charge VBUS 1: charge VBUS															
17	RXACTIVE	Output	High	Receive Active. Indicates that the receive state machine has detected Start of Packet and is active.															
18	OPMODE[1]	Input	N/A	Operational Mode. These signals select between the various operational modes: <table border="1" style="font-size: small;"> <thead> <tr> <th>[1]</th> <th>[0]</th> <th>Description</th> </tr> </thead> <tbody> <tr> <td>0</td> <td>0</td> <td>0: Normal Operation</td> </tr> <tr> <td>0</td> <td>1</td> <td>1: Non-driving (all terminations removed)</td> </tr> <tr> <td>1</td> <td>0</td> <td>2: Disable bit stuffing and NRZI encoding</td> </tr> <tr> <td>1</td> <td>1</td> <td>3: Reserved</td> </tr> </tbody> </table>	[1]	[0]	Description	0	0	0: Normal Operation	0	1	1: Non-driving (all terminations removed)	1	0	2: Disable bit stuffing and NRZI encoding	1	1	3: Reserved
[1]	[0]	Description																	
0	0	0: Normal Operation																	
0	1	1: Non-driving (all terminations removed)																	
1	0	2: Disable bit stuffing and NRZI encoding																	
1	1	3: Reserved																	
19	OPMODE[0]	Input	N/A																
20	ID_DIG	Output	High	ID Digital. Indicates the state of the ID pin. 0: connected plug is a mini-A 1: connected plug is a mini-B															
21	IDPULLUP	Input	High	ID Pull-up. Enables sampling of the analog ID line. Disabling the ID line sampler will reduce PHY power consumption. 0: Disable sampling of ID line. 1: Enable sampling of ID line.															
22	VSS	Ground	N/A	PHY ground.															
23	CLKOUT	Output, CMOS	N/A	60MHz reference clock output. All UTMI+ signals are driven synchronous to this clock.															
24	VSS	Ground	N/A	PHY ground.															
25	LINESTATE[1]	Output	N/A	Line State. These signals reflect the current state of the USB data bus in FS mode. Bit [0] reflects the state of DP and bit [1] reflects the state of DM. When the device is suspended or resuming from a suspended state, the signals are combinatorial. Otherwise, the signals are synchronized to CLKOUT. <table border="1" style="font-size: small;"> <thead> <tr> <th>[1]</th> <th>[0]</th> <th>Description</th> </tr> </thead> <tbody> <tr> <td>0</td> <td>0</td> <td>0: SEO</td> </tr> <tr> <td>0</td> <td>1</td> <td>1: J State</td> </tr> <tr> <td>1</td> <td>0</td> <td>2: K State</td> </tr> <tr> <td>1</td> <td>1</td> <td>3: SE1</td> </tr> </tbody> </table>	[1]	[0]	Description	0	0	0: SEO	0	1	1: J State	1	0	2: K State	1	1	3: SE1
[1]	[0]	Description																	
0	0	0: SEO																	
0	1	1: J State																	
1	0	2: K State																	
1	1	3: SE1																	
26	LINESTATE[0]	Output	N/A																
27	VDD1.8	N/A	N/A	1.8V regulator output for digital circuitry on chip. Place a 0.1uF capacitor near this pin and connect the capacitor from this pin to ground. Connect pin 27 to pin 49.															

Table 3.1 USB3500 Pin Definitions (continued)

PIN	NAME	DIRECTION, TYPE	ACTIVE LEVEL	DESCRIPTION
28	VDD3.3	N/A	N/A	3.3V PHY Supply. Provides power for USB 2.0 Transceiver, UTMI+ Digital, Digital I/O, and Regulators.
29	HOSTDISC	Output	High	Host Disconnect. In HS Host mode this indicates to that a downstream device has been disconnected. Automatically reset to 0b when Low Power Mode is entered.
30	DISCHRGVBUS	Input	High	Discharge VBUS through a resistor to ground. 0: do not discharge VBUS 1: discharge VBUS
31	SESSEND	Output	High	Session End. Indicates that the voltage on Vbus is below its B-Device Session End threshold. 0: $V_{BUS} > V_{SessEnd}$ 1: $V_{BUS} < V_{SessEnd}$
32	DATA[7]	I/O, CMOS, Pull-low	N/A	8-bit bi-directional data bus. Data[7] is the MSB and Data[0] is the LSB.
33	DATA[6]	I/O, CMOS, Pull-low	N/A	
34	DATA[5]	I/O, CMOS, Pull-low	N/A	
35	DATA[4]	I/O, CMOS, Pull-low	N/A	
36	DATA[3]	I/O, CMOS, Pull-low	N/A	
37	DATA[2]	I/O, CMOS, Pull-low	N/A	
38	DATA[1]	I/O, CMOS, Pull-low	N/A	
39	DATA[0]	I/O, CMOS, Pull-low	N/A	
40	VSS	Ground	N/A	PHY ground.
41	RXVALID	Output	High	Receive Data Valid. Indicates that the DATA bus has received valid data. The Receive Data Holding Register is full and ready to be unloaded. The Link is expected to register the DATA bus on the next rising edge of CLKOUT.
42	SESSVLD	Output	High	Session Valid. Indicates that the voltage on Vbus is above the indicated threshold. 0: $V_{BUS} < V_{SessVld}$ 1: $V_{BUS} > V_{SessVld}$

Table 3.1 USB3500 Pin Definitions (continued)

PIN	NAME	DIRECTION, TYPE	ACTIVE LEVEL	DESCRIPTION
43	DPPD	Input	N/A	DP Pull-down Select. This signal enables the 15k Ohm pull-down resistor on the DP line. 0: Pull-down resistor not connected to DP 1: Pull-down resistor connected to DP
44	DMPD	Input	N/A	DM Pull-down Select. This signal enables the 15k Ohm pull-down resistor on the DM line. 0: Pull-down resistor not connected to DM 1: Pull-down resistor connected to DM
45	RXERROR	Output	High	Receive Error. This output is clocked with the same timing as the receive DATA lines and can occur at anytime during a transfer. 0: Indicates no error. 1: Indicates a receive error has been detected.
46	VSS	Ground	N/A	PHY ground.
47	VBUSVLD	Output	High	VBUS Valid. Indicates that the voltage on Vbus is above the indicated threshold. 0: $V_{BUS} < V_{VbusVld}$ 1: $V_{BUS} > V_{VbusVld}$
48	VDD3.3	N/A	N/A	3.3V PHY Supply. Provides power for USB 2.0 Transceiver, UTMI+ Digital, Digital I/O, and Regulators.
49	VDD1.8	N/A	N/A	1.8V regulator output for digital circuitry on chip. Place a 4.7uF low ESR capacitor near this pin and connect the capacitor from this pin to ground. Connect pin 49 to pin 27. See Section 6.6, "Internal Regulators and POR," on page 27.
50	VSS	Ground	N/A	PHY ground.
51	XO	Output, Analog	N/A	Crystal pin. If using an external clock on XI this pin should be floated.
52	XI	Input, Analog	N/A	Crystal pin. A 24MHz crystal is supported. The crystal is placed across XI and XO. An external 24MHz clock source may be driven into XI in place of a crystal.
53	VDDA1.8	N/A	N/A	1.8V regulator output for analog circuitry on chip. Place a 0.1uF capacitor near this pin and connect the capacitor from this pin to ground. In parallel, place a 4.7uF low ESR capacitor near this pin and connect the capacitor from this pin to ground. See Section 6.6, "Internal Regulators and POR,"
54	VDD3.3	N/A	N/A	3.3V PHY Supply. Provides power for USB 2.0 Transceiver, UTMI+ Digital, Digital I/O, and Regulators.
55	VDD3.3	N/A	N/A	3.3V PHY Supply. Should be connected directly to pin 54.
56	RBIAS	Analog, CMOS	N/A	External 1% bias resistor. Requires a 12KΩ resistor to ground.
	GND FLAG	Ground	N/A	Ground. The flag must be connected to the ground plane.

Chapter 4 Limiting Values

Table 4.1 Maximum Guaranteed Ratings

PARAMETER	SYMBOL	CONDITIONS	MIN	TYP	MAX	UNITS
Maximum VBUS, ID, DP, and DM voltage to Ground	V_{MAX_5V}		-0.5		+5.5	V
Maximum VDD1.8 and VDDA1.8 voltage to Ground	$V_{MAX_1.8V}$		-0.5		2.5	V
Maximum 3.3V supply voltage to Ground	$V_{MAX_3.3V}$		-0.5		4.0	V
Maximum I/O voltage to Ground	V_{MAX_IN}		-0.5		4.0	V
Operating Temperature	T_{MAX_OP}		0		70	C
Storage Temperature	T_{MAX_STG}		-55		150	C

Note: Stresses above those listed could cause damage to the device. This is a stress rating only and functional operation of the device at any other condition above those indicated in the operation sections of this specification is not implied. When powering this device from laboratory or system power supplies, it is important that the Absolute Maximum Ratings not be exceeded or device failure can result. Some power supplies exhibit voltage spikes on their outputs when the AC power is switched on or off. In addition, voltage transients on the AC power line may appear on the DC output. If this possibility exists, it is suggested that a clamp circuit be used.

Table 4.2 Recommended Operating Conditions

PARAMETER	SYMBOL	CONDITIONS	MIN	TYP	MAX	UNITS
3.3V Supply Voltage	$V_{DD3.3}$		3.0	3.3	3.6	V
Input Voltage on Digital Pins	V_I		0.0		$V_{DD3.3}$	V
Input Voltage on Analog I/O Pins (DP, DM)	$V_{I(I/O)}$		0.0		$V_{DD3.3}$	V
Ambient Temperature	T_A		0		+70	°C

Table 4.3 Recommended External Clock Conditions

PARAMETER	SYMBOL	CONDITIONS	MIN	TYP	MAX	UNITS
System Clock Frequency		XI driven by the external clock; and no connection at XO		24 (±100ppm)		MHz
System Clock Duty Cycle		XI driven by the external clock; and no connection at XO	45	50	55	%

Chapter 5 Electrical Characteristics

Table 5.1 DC Electrical Characteristics: Supply Pins (Note 1)

PARAMETER	SYMBOL	CONDITIONS	MIN	TYP	MAX	UNITS
Unconfigured Current	$I_{AVG(UCFG)}$	Device Unconfigured		55		mA
FS Idle Current	$I_{AVG(FS)}$	FS idle not data transfer		55		mA
FS Transmit Current	$I_{AVG(FSTX)}$	FS current during data transmit		60.5		mA
FS Receive Current	$I_{AVG(FSRX)}$	FS current during data receive		57.5		mA
HS Idle Current	$I_{AVG(HS)}$	FS idle not data transfer		60.6		mA
HS Transmit Current	$I_{AVG(HSTX)}$	FS current during data transmit		62.4		mA
HS Receive Current	$I_{AVG(HSRX)}$	FS current during data receive		61.5		mA
Low Power Mode	$I_{DD(LPM)}$	VBUS 15k Ω pull-down and 1.5k Ω pull-up resistor currents not included.		83		μ A

Note: $V_{DD3.3} = 3.0$ to $3.6V$; $V_{SS} = 0V$; $T_A = 0C$ to $+70C$; unless otherwise specified.

Table 5.2 Electrical Characteristics: CLKOUT Start-Up

PARAMETER	SYMBOL	CONDITIONS	MIN	TYP	MAX	UNITS
Suspend Recovery Time	T_{START}			2.25	3.5	ms

Note: $V_{DD3.3} = 3.0$ to $3.6V$; $V_{SS} = 0V$; $T_A = 0C$ to $+70C$; unless otherwise specified.

Table 5.3 DC Electrical Characteristics: Logic Pins

PARAMETER	SYMBOL	CONDITIONS	MIN	TYP	MAX	UNITS
Low-Level Input Voltage	V_{IL}		V_{SS}		0.8	V
High-Level Input Voltage	V_{IH}		2.0		$V_{DD3.3}$	V
Low-Level Output Voltage	V_{OL}	$I_{OL} = 8mA$			0.4	V
High-Level Output Voltage	V_{OH}	$I_{OH} = -8mA$	$V_{DD3.3} - 0.4$			V
Input Leakage Current	I_{LI}				± 10	μ A
Pin Capacitance	C_{pin}				4	pF

Note: $V_{DD3.3} = 3.0$ to $3.6V$; $V_{SS} = 0V$; $T_A = 0C$ to $+70C$; unless otherwise specified.

Table 5.4 DC Electrical Characteristics: Analog I/O Pins (DP/DM)

PARAMETER	SYMBOL	CONDITIONS	MIN	TYP	MAX	UNITS
FS FUNCTIONALITY						
Input levels						
Differential Receiver Input Sensitivity	V_{DIFS}	$ V(DP) - V(DM) $	0.2			V
Differential Receiver Common-Mode Voltage	V_{CMFS}		0.8		2.5	V
Single-Ended Receiver Low Level Input Voltage	V_{ILSE}				0.8	V
Single-Ended Receiver High Level Input Voltage	V_{IHSE}		2.0			V
Single-Ended Receiver Hysteresis	V_{HYSSE}		0.050		0.150	V
Output Levels						
Low Level Output Voltage	V_{FSOL}	Pull-up resistor on DP; $R_L = 1.5k\Omega$ to $V_{DD3.3}$			0.3	V
High Level Output Voltage	V_{FSOH}	Pull-down resistor on DP, DM; $R_L = 15k\Omega$ to GND	2.8		3.6	V
Termination						
Driver Output Impedance for HS and FS	Z_{HSDRV}	Steady state drive	40.5	45	49.5	Ω
Input Impedance	Z_{INP}	TX, RPU disabled	1.0			M Ω
Pull-up Resistor Impedance	Z_{PU}	Bus Idle	0.900	1.24	1.575	k Ω
Pull-up Resistor Impedance	Z_{PURX}	Device Receiving	1.425	2.26	3.09	k Ω
Pull-dn Resistor Impedance	Z_{PD}		14.25	15.0	15.75	k Ω
HS FUNCTIONALITY						
Input levels						
HS Differential Input Sensitivity	V_{DIHS}	$ V(DP) - V(DM) $	100			mV
HS Data Signaling Common Mode Voltage Range	V_{CMHS}		-50		500	mV
HS Squelch Detection Threshold (Differential)	V_{HSSQ}	Squelch Threshold			100	mV
		Un-squelch Threshold	150			mV
Output Levels						
Hi-Speed Low Level Output Voltage (DP/DM referenced to GND)	V_{HSOL}	45 Ω load	-10		10	mV

Table 5.4 DC Electrical Characteristics: Analog I/O Pins (DP/DM) (continued)

PARAMETER	SYMBOL	CONDITIONS	MIN	TYP	MAX	UNITS
Hi-Speed High Level Output Voltage (DP/DM referenced to GND)	V_{HSOH}	45Ω load	360		440	mV
Hi-Speed IDLE Level Output Voltage (DP/DM referenced to GND)	V_{OLHS}	45Ω load	-10		10	mV
Chirp-J Output Voltage (Differential)	V_{CHIRPJ}	HS termination resistor disabled, pull-up resistor connected. 45Ω load.	700		1100	mV
Chirp-K Output Voltage (Differential)	V_{CHIRPK}	HS termination resistor disabled, pull-up resistor connected. 45Ω load.	-900		-500	mV
Leakage Current						
OFF-State Leakage Current	I_{LZ}				±10	uA
Port Capacitance						
Transceiver Input Capacitance	C_{IN}	Pin to GND		5	10	pF

Note: $V_{DD3.3} = 3.0$ to $3.6V$; $V_{SS} = 0V$; $T_A = 0C$ to $+70C$; unless otherwise specified.

Table 5.5 Dynamic Characteristics: Analog I/O Pins (DP/DM)

PARAMETER	SYMBOL	CONDITIONS	MIN	TYP	MAX	UNITS
FS Output Driver Timing						
Rise Time	T_{FSR}	$C_L = 50pF$; 10 to 90% of $ V_{OH} - V_{OL} $	4		20	ns
Fall Time	T_{FFF}	$C_L = 50pF$; 10 to 90% of $ V_{OH} - V_{OL} $	4		20	ns
Output Signal Crossover Voltage	V_{CRS}	Excluding the first transition from IDLE state	1.3		2.0	V
Differential Rise/Fall Time Matching	FRFM	Excluding the first transition from IDLE state	90		111.1	%
HS Output Driver Timing						
Differential Rise Time	T_{HSR}		500			ps
Differential Fall Time	T_{HSF}		500			ps
Driver Waveform Requirements		Eye pattern of Template 1 in USB 2.0 specification				
Hi-Speed Mode Timing						
Receiver Waveform Requirements		Eye pattern of Template 4 in USB 2.0 specification				
Data Source Jitter and Receiver Jitter Tolerance		Eye pattern of Template 4 in USB 2.0 specification				

Datasheet

Note: $V_{DD3.3} = 3.0$ to $3.6V$; $V_{SS} = 0V$; $T_A = 0C$ to $+70C$; unless otherwise specified.

Table 5.6 Dynamic Characteristics: Digital UTMI Pins

PARAMETER	SYMBOL	CONDITIONS	MIN	TYP	MAX	UNITS
UTMI Timing						
DATA[7:0]	T_{PD}	Output Delay. Measured from PHY output to the rising edge of CLKOUT	2		5	ns
RXVALID						
RXACTIVE						
RXERROR						
LINESTATE[1:0]						
TXREADY						
DATA[7:0]	T_{SU}	Setup Time. Measured from PHY input to the rising edge of CLKOUT.	5		1	ns
TXVALID						
OPMODE[1:0]						
XCVRSELECT[1:0]						
TERMSELECT						
DATA[7:0]	T_H	Hold time. Measured from the rising edge of CLKOUT to the PHY input signal edge.	0			ns
TXVALID						
OPMODE[1:0]						
XCVRSELECT[1:0]						
TERMSELECT						

Note: $V_{DD3.3} = 3.0$ to $3.6V$; $V_{SS} = 0V$; $T_A = 0C$ to $+70C$; unless otherwise specified.

Table 5.7 OTG Electrical Characteristics

PARAMETER	SYMBOL	CONDITIONS	MIN	TYP	MAX	UNITS
SessEnd trip point	$V_{SessEnd}$		0.2	0.5	0.8	V
SessVld trip point	$V_{SessVld}$		0.8	1.4	2.0	V
VBUSVld trip point	$V_{VbusVld}$		4.4	4.58	4.75	V
Vbus Pull-Up	R_{VbusPu}	Vbus to VDD3.3 (CHRGVBUS = 1)	281	340		Ω
Vbus Pull-down	R_{VbusPd}	Vbus to GND (DISCHRGVBUS = 1)	656	850		Ω
Vbus Impedance	R_{Vbus}	Vbus to GND	40	75	100	k Ω
ID pull-up resistance	$R_{IdPullUp}$	(IDOULLUP = 1)	80	100	120	k Ω
ID pull-up resistance	R_{Id}	(IDPULLUP = 0)	1			M Ω

Note: $V_{DD3.3} = 3.0$ to $3.6V$; $V_{SS} = 0V$; $T_A = 0C$ to $+70C$; unless otherwise specified

Table 5.8 Regulator Output Voltages

PARAMETER	SYMBOL	CONDITIONS	MIN	TYP	MAX	UNITS
$V_{DDA1.8}$	$V_{DDA1.8}$	Normal Operation (SUSPENDN = 1)	1.6	1.8	2.0	V
$V_{DDA1.8}$	$V_{DDA1.8}$	Low Power mode (SUSPENDN = 0)		0		V
$V_{DD1.8}$	$V_{DD1.8}$		1.6	1.8	2.0	V

Note: $V_{DD3.3} = 3.0$ to $3.6V$; $V_{SS} = 0V$; $T_A = 0C$ to $+70C$; unless otherwise specified

Chapter 6 Detailed Functional Description

Figure 2.1 on page 9 shows the functional block diagram of the USB3500. Each of the functions is described in detail below.

6.1 8bit Bi-Directional Data Bus Operation

The USB3500 supports an 8-bit bi-directional parallel interface.

- CLKOUT runs at 60MHz
- The 8-bit data bus (DATA[7:0]) is used for transmit when TXVALID = 1
- The 8-bit data bus (DATA[7:0]) is used for receive when TXVALID = 0

Figure 6.1 shows the relationship between CLKOUT and the transmit data transfer signals in FS mode. TXREADY is only asserted for one CLKOUT per byte time to signal the Link that the data on the DATA lines has been read by the PHY. The Link may hold the data on the DATA lines for the duration of the byte time. Transitions of TXVALID must meet the defined setup and hold times relative to CLKOUT.

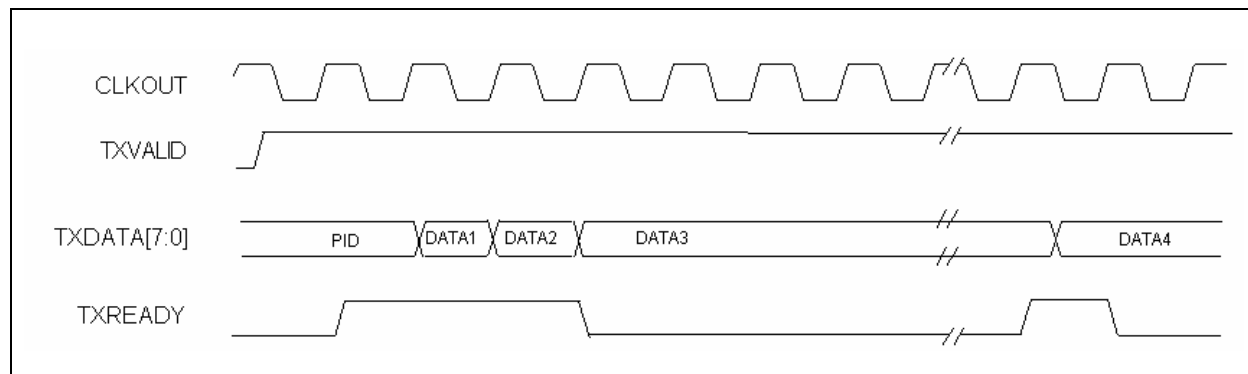

Figure 6.1 FS CLK Relationship to Transmit Data and Control Signals

Figure 6.2 shows the relationship between CLKOUT and the receive data control signals in FS mode. RXACTIVE “frames” a packet, transitioning only at the beginning and end of a packet. However transitions of RXVALID may take place any time 8 bits of data are available. Figure 6.2 also shows how RXVALID is only asserted for one CLKOUT cycle per byte time even though the data may be presented for the full byte time. The XCVRSELECT signal determines whether the HS or FS timing relationship is applied to the data and control signals.

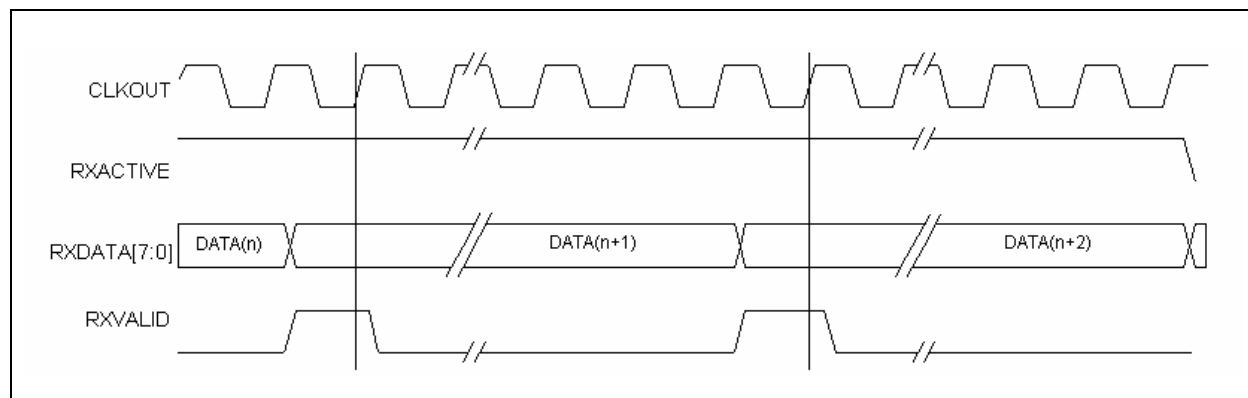

Figure 6.2 FS CLK Relationship to Receive Data and Control Signals

6.2 TX Logic

This block receives parallel data bytes placed on the DATA bus and performs the necessary transmit operations. These operations include parallel to serial conversion, bit stuffing and NRZI encoding. Upon valid assertion of the proper TX control lines by the Link and TX State Machine, the TX LOGIC block will synchronously shift, at either the FS or HS rate, the data to the FS/HS TX block to be transmitted on the USB cable. Data transmit timing is shown in [Figure 6.3](#).

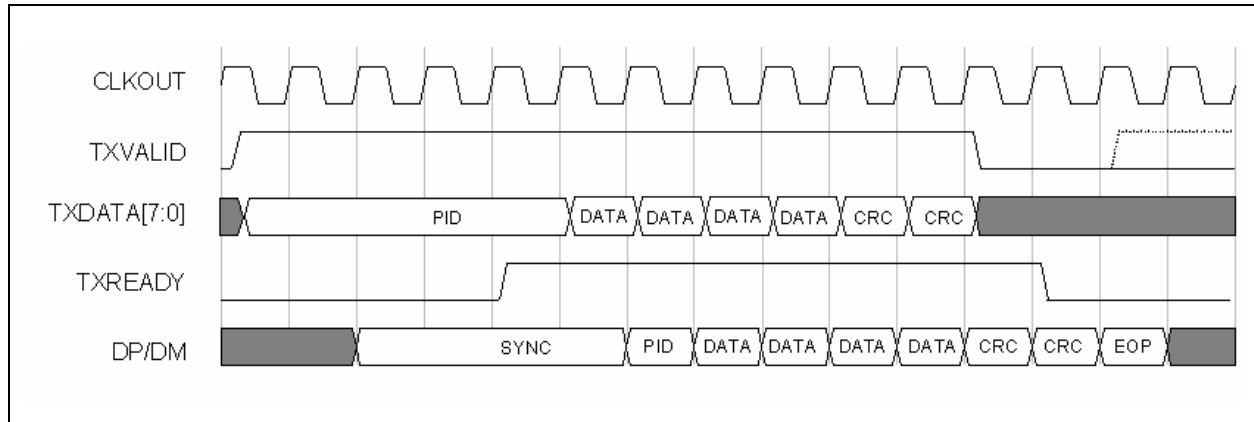

Figure 6.3 Transmit Timing for a Data Packet

The behavior of the Transmit State Machine is described below.

- The Link asserts TXVALID to begin a transmission.
- After the Link asserts TXVALID it can assume that the transmission has started when it detects TXREADY has been asserted.
- The Link must assume that the USB3500 has consumed a data byte if TXREADY and TXVALID are asserted on the rising edge of CLKOUT.
- The Link must have valid packet information (PID) asserted on the DATA bus coincident with the assertion of TXVALID.
- TXREADY is sampled by the Link on the rising edge of CLKOUT.
- The Link negates TXVALID to complete a packet. Once negated, the transmit logic will never reassert TXREADY until after the EOP has been generated. (TXREADY will not re-assert until TXVALID asserts again.)
- The USB3500 is ready to transmit another packet immediately. However, the Link must conform to the minimum inter-packet delays identified in the USB 2.0 specification.
- Supports high speed disconnect detect through the HOSTDISC pin. In Host mode the USB3500 will sample the disconnect comparator at the 32nd bit of the 40 bit long EOP during SOF packets.
- Supports FS pre-amble for FS hubs with a LS device.
- Supports LS keep alive by receiving the SOF PID.
- Supports Host mode resume K which ends with two low speed times of SE0 followed by 1 FS “J”.

6.3 RX Logic

This block receives serial data from the clock recovery circuits and processes it to be transferred to the Link on the DATA bus. The processing involved includes NRZI decoding, bit unstuffing, and serial to parallel conversion. Upon valid assertion of the proper RX control lines, the RX Logic block will provide bytes to the DATA bus as shown in the figures below. The behavior of the receiver is described below.

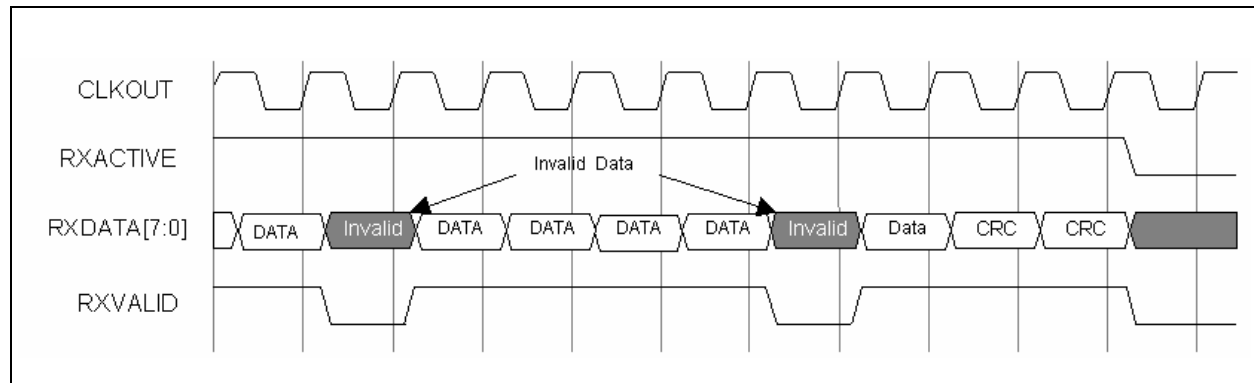

Figure 6.4 Receive Timing for Data with Unstuffed Bits

The assertion of RESET will cause the USB3500 to deasserts RXACTIVE and RXVALID. When the RESET signal is deasserted the Receive State Machine starts looking for a SYNC pattern on the USB. When a SYNC pattern is detected, the receiver will assert RXACTIVE. The length of the received Hi-Speed SYNC pattern varies and can be up to 32 bits long or as short as 12 bits long when at the end of five hubs.

After valid serial data is received, the data is loaded into the RX Holding Register on the rising edge of CLKOUT, and RXVALID is asserted. The Link must read the DATA bus on the next rising edge of CLKOUT. In normal mode (OPMODE = 00), then stuffed bits are stripped from the data stream. Each time 8 stuffed bits are accumulated the USB3500 will negate RXVALID for one clock cycle, thus skipping a byte time.

When the EOP is detected the USB3500 will negate RXACTIVE and RXVALID. After the EOP has been stripped, the USB3500 will begin looking for the next packet.

The behavior of the USB3500 receiver is described below:

- RXACTIVE and RXREADY are sampled on the rising edge of CLKOUT.
- After a EOP is complete the receiver will begin looking for SYNC.
- The USB3500 asserts RXACTIVE when SYNC is detected.
- The USB3500 negates RXACTIVE when an EOP is detected and the elasticity buffer is empty.
- When RXACTIVE is asserted, RXVALID will be asserted if the RX Holding Register is full.
- RXVALID will be negated if the RX Holding Register was not loaded during the previous byte time. This will occur if 8 stuffed bits have been accumulated.
- The Link must be ready to consume a data byte if RXACTIVE and RXVALID are asserted (RX Data state).
- [Figure 6.5](#) shows the timing relationship between the received data (DP/DM), RXVALID, RXACTIVE, RXERROR and DATA signals.

Notes:

- [Figure 6.5](#), [Figure 6.6](#) and [Figure 6.7](#) are timing examples of a HS/FS PHY when it is in HS mode. When a HS/FS PHY is in FS Mode there are approximately 40 CLKOUT cycles every byte time. The Receive State Machine assumes that the Link captures the data on the DATA bus if RXACTIVE and RXVALID are asserted. In FS mode, RXVALID will only be asserted for one CLKOUT per byte time.
- In [Figure 6.5](#), [Figure 6.6](#) and [Figure 6.7](#) the SYNC pattern on DP/DM is shown as one byte long. The SYNC pattern received by a device can vary in length. These figures assume that all but the last 12 bits have been consumed by the hubs between the device and the host controller.

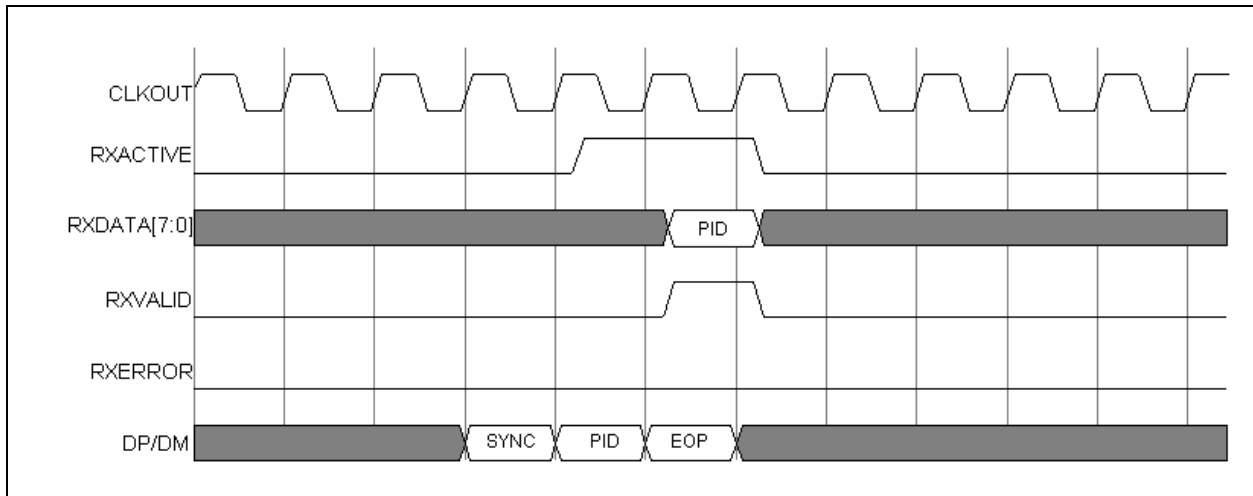

Figure 6.5 Receive Timing for a Handshake Packet (no CRC)

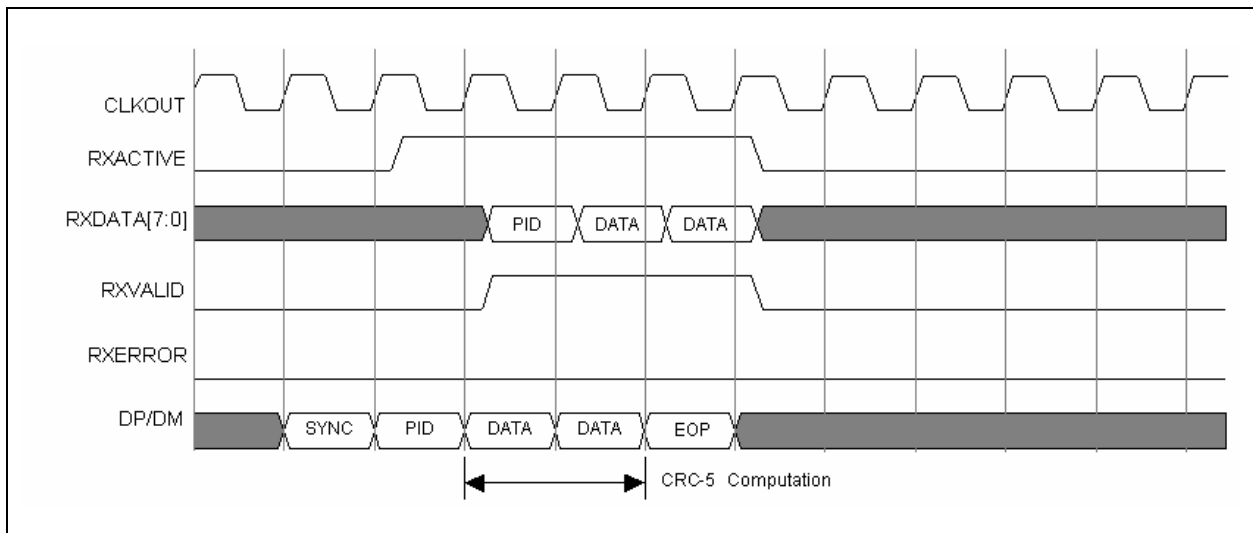

Figure 6.6 Receive Timing for Setup Packet

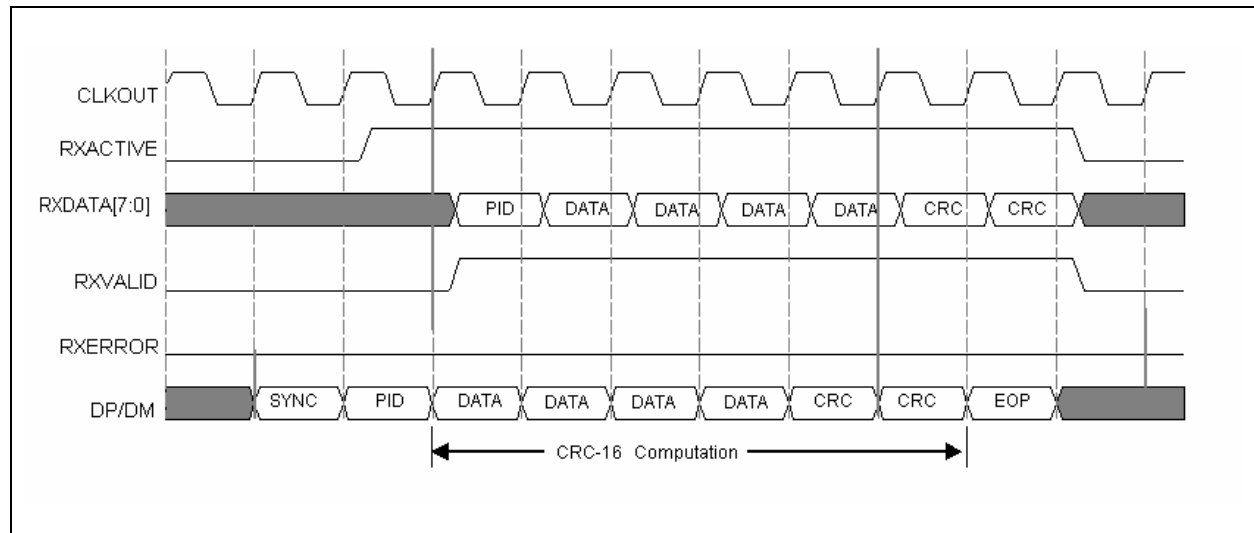

Figure 6.7 Receive Timing for Data Packet (with CRC-16)

6.4 USB 2.0 Transceiver

The SMSC Hi-Speed USB 2.0 Transceiver consists of four blocks in the lower left corner of [Figure 2.1 on page 9](#). These four blocks are labeled HS XCVR, FS/LS XCVR, Resistors, and Bias Gen.

6.4.1 High Speed and Full Speed Transceivers

The USB3500 transceiver meets all requirements in the USB 2.0 specification.

The receivers connect directly to the USB cable. This block contains a separate differential receiver for HS and FS mode. Depending on the mode, the selected receiver provides the serial data stream through the multiplexer to the RX Logic block. The FS mode section of the FS/HS RX block also consists of a single-ended receiver on each of the data lines to determine the correct FS linestate. For HS mode support, the FS/HS RX block contains a squelch circuit to insure that noise is never interpreted as data.

The transmitters connect directly to the USB cable. The block contains a separate differential FS and HS transmitter which receive encoded, bit stuffed, serialized data from the TX Logic block and transmit it on the USB cable.

6.4.2 Termination Resistors

The USB3500 transceiver fully integrates all of the USB termination resistors. The USB3500 includes two 1.5k Ω pull-up resistors on DP and DM and a 15k Ω pull-down resistor on both DP and DM. In addition the 45 Ω high speed termination resistors are also integrated. These integrated resistors require no tuning or trimming by the Link. The state of the resistors is determined by the operating mode of the PHY. The possible valid resistor combinations are shown in [Table 6.1](#). The RESISTOR SETTINGS signals shown in the table are internal to the USB3500.

- RPU_DP_EN activates the 1.5k Ω DP pull-up resistor
- RPU_DM_EN activates the 1.5k Ω DM pull-up resistor
- RPD_DP_EN activates the 15k Ω DP pull-down resistor
- RPD_DM_EN activates the 15k Ω DM pull-down resistor

- HSTERM_EN activates the 45Ω DP and DM high speed termination resistors

Table 6.1 DP/DM termination vs. Signaling Mode

SIGNALING MODE	UTMI+ INTERFACE SETTINGS					RESISTOR SETTINGS				
	XCVRSEL[1:0]	TERMSEL	OPMODE[1:0]	DPPD	DMPD	RPU_DP_EN	RPU_DM_EN	RPD_DP_EN	RPD_DM_EN	HSTERM_EN
General Settings										
Tri-State Drivers	XXb	Xb	01b	Xb	Xb	0b	0b	0b	0b	0b
Power-up or Vbus < V _{SESEND}	01b	0b	00b	1b	1b	0b	0b	1b	1b	0b
Host Settings										
Host Chirp	00b	0b	10b	1b	1b	0b	0b	1b	1b	1b
Host Hi-Speed	00b	0b	00b	1b	1b	0b	0b	1b	1b	1b
Host Full Speed	X1b	1b	00b	1b	1b	0b	0b	1b	1b	0b
Host HS/FS Suspend	01b	1b	00b	1b	1b	0b	0b	1b	1b	0b
Host HS/FS Resume	01b	1b	10b	1b	1b	0b	0b	1b	1b	0b
Host low Speed	10b	1b	00b	1b	1b	0b	0b	1b	1b	0b
Host LS Suspend	10b	1b	00b	1b	1b	0b	0b	1b	1b	0b
Host LS Resume	10b	1b	10b	1b	1b	0b	0b	1b	1b	0b
Host Test J/Test_K	00b	0b	10b	1b	1b	0b	0b	1b	1b	1b
Peripheral Settings										
Peripheral Chirp	00b	1b	10b	0b	0b	1b	0b	0b	0b	0b
Peripheral HS	00b	0b	00b	0b	0b	0b	0b	0b	0b	1b
Peripheral FS	01b	1b	00b	0b	0b	1b	0b	0b	0b	0b
Peripheral HS/FS Suspend	01b	1b	00b	0b	0b	1b	0b	0b	0b	0b
Peripheral HS/FS Resume	01b	1b	10b	0b	0b	1b	0b	0b	0b	0b
Peripheral LS	10b	1b	00b	0b	0b	0b	1b	0b	0b	0b
Peripheral LS Suspend	10b	1b	00b	0b	0b	0b	1b	0b	0b	0b
Peripheral LS Resume	10b	1b	10b	0b	0b	0b	1b	0b	0b	0b
Peripheral Test J/Test K	00b	0b	10b	0b	0b	0b	0b	0b	0b	1b
OTG device, Peripheral Chirp	00b	1b	10b	0b	1b	1b	0b	0b	1b	0b
OTG device, Peripheral HS	00b	0b	00b	0b	1b	0b	0b	0b	1b	1b
OTG device, Peripheral FS	01b	1b	00b	0b	1b	1b	0b	0b	1b	0b
OTG device, Peripheral HS/FS Suspend	01b	1b	00b	0b	1b	1b	0b	0b	1b	0b

Table 6.1 DP/DM termination vs. Signaling Mode (continued)

SIGNALING MODE	UTMI+ INTERFACE SETTINGS					RESISTOR SETTINGS				
	XCVRSEL[1:0]	TERMSEL	OPMODE[1:0]	DPPD	DMPD	RPU_DP_EN	RPU_DM_EN	RPD_DP_EN	RPD_DM_EN	HSTERM_EN
OTG device, Peripheral HS/FS Resume	01b	1b	10b	0b	1b	1b	0b	0b	1b	0b
OTG device, Peripheral Test J/Test K	00b	0b	10b	0b	1b	0b	0b	0b	1b	1b

6.4.3 Bias Generator

This block consists of an internal bandgap reference circuit used for generating the high speed driver currents and the biasing of the analog circuits. This block requires an external 12K Ω , 1% tolerance, external reference resistor connected from RBIAS to ground.

6.5 Crystal Oscillator and PLL

The USB3500 uses an internal crystal driver and PLL sub-system to provide a clean 480MHz reference clock that is used by the PHY during both transmit and receive. The USB3500 requires a clean 24MHz crystal or clock as a frequency reference. If the 24MHz reference is noisy or off frequency the PHY may not operate correctly.

The USB3500 can use either a crystal or an external clock oscillator for the 24MHz reference. The crystal is connected to the XI and XO pins as shown in the application diagram, [Figure 7.10](#). If a clock oscillator is used, the clock should be connected to the XI input and the XO pin left floating. When using an external clock, the clock source must be clean so it does not degrade performance, and should be driven with a 0 to 3.3 volt signal.

After the 480MHz PLL has locked to the correct frequency, it will drive the CLKOUT pin with a 60MHz clock. The USB3500 is guaranteed to start the clock within the time specified in [Table 5.2](#).

6.6 Internal Regulators and POR

The USB3500 includes integrated power management functions to reduce the bill of materials and simplify product design.

6.6.1 Internal Regulators

The USB3500 has two internal regulators that create two 1.8V outputs (labeled VDD1.8 and VDDA1.8) from the 3.3 volt power supply input (VDD3.3). Each regulator requires an external 4.7 μ F +/-20% low ESR bypass capacitor to ensure stability. X5R or X7R ceramic capacitors are recommended since they exhibit an ESR lower than 0.1ohm at frequencies greater than 10kHz.

The specific capacitor recommendations for each pin are detailed in [Table 3.1](#), "USB3500 Pin Locations", and shown in [Figure 7.10](#), "USB3500 Application Diagram (Top View)".

Note: The USB3500 regulators are designed to generate a 1.8volt supply for the USB3500 only. Using the regulators to provide current for other circuits is not recommended and SMSC does not guarantee USB performance or regulator stability in this case.

6.6.2 Power On Reset (POR)

The USB3500 provides an internal POR circuit that generates a reset pulse once the PHY supplies are stable. The UTMI+ Digital can be reset at any time with the RESET pin.

6.7 USB On-The-Go (OTG) Module

The USB3500 provides support for USB OTG. This mode allows the USB3500 to be dynamically configured as a host or a device depending on the type of cable inserted into the Mini-AB connector. When the Mini-A plug of a cable is inserted into the Mini-AB connector the USB device becomes the A-device. When a Mini-B plug is inserted the device becomes the B-device. The OTG A-device behaves similar to a Host while the B-device behaves similar to a peripheral. The differences are covered in the OTG supplement.

The OTG Module meets all the requirements in the “On-The-Go Supplement to the USB 2.0 Specification”. In applications where only Host or Device is required, the OTG Module is unused.

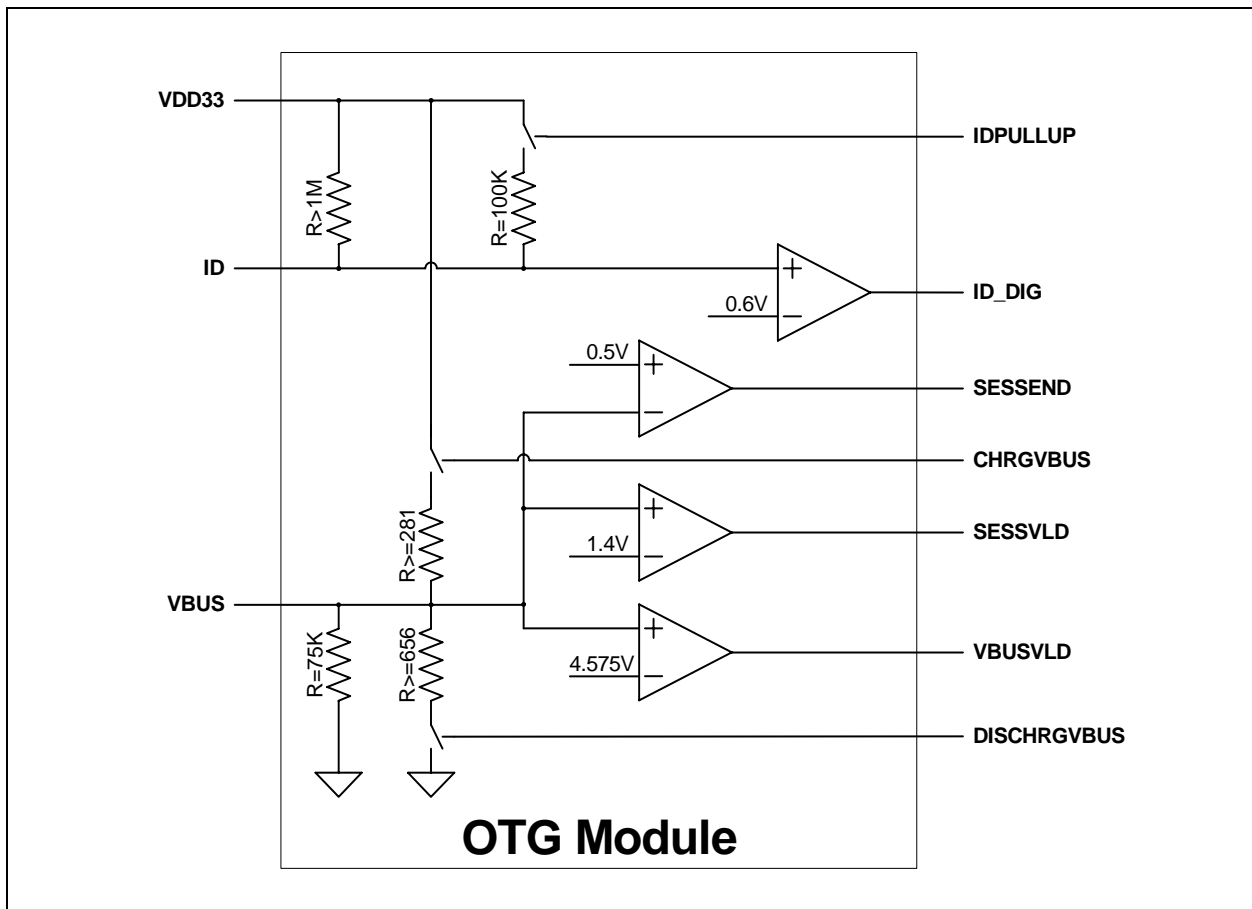

Figure 6.8 USB3500 On-the-Go Module

The OTG Module can be broken into 4 main blocks; ID Detection, VBUS Control, Driving External VBUS, and External VBUS Detection. Each of these blocks is covered in the sections below.

6.7.1 ID Detection

The USB3500 provides an ID pin to determine the type of USB cable connected. When the Mini-A Plug of a USB cable is inserted into the Mini-AB connector, the ID pin is shorted to ground. When the Mini-B Plug is inserted into the Mini-AB connector, the ID pin is allowed to float.

Table 6.2 IdGnd vs. USB Cable Type

USB PLUG	OTG ROLE	ID VOLTAGE	IDGND
A	HOST	0	0
B	PERIPHERAL	3.3	1

The USB3500 provides an integrated pull-up resistor to pull the ID pin to VDD3.3 when a Mini-B plug is inserted and the cable is floating. When a Mini-A plug is connected, the pull-up resistor will be overpowered and the ID pin will be brought to ground. To save current when a Mini-A Plug is inserted, the ID pull-up resistor can be disabled by clearing the IDPULLUP pin. To prevent the ID pin from floating to a random value, a weak pull-up resistor is provided at all times. The circuits related to the ID comparator are shown in [Figure 6.8](#) and their related parameters are shown in [Table 5.7](#).

6.7.2 VBUS Control

The USB3500 includes all of the Vbus comparators required for OTG. The VbusVId, SessVId, and SessEnd comparators are fully integrated into the USB3500. These comparators are used to ensure the Vbus voltage is the correct value for proper USB operation.

The VbusVId comparator is used by the Link, when configured as an A device, to ensure that the Vbus voltage on the cable is valid. The SessVId comparator is used by the Link when configured as either an A or B device to indicate a session is requested or valid. Finally the SessEnd comparator is used by the B-device to indicate a USB session has ended.

Also included in the VBUS Control block are the resistors used for VBUS pulsing in SRP. The resistors used for VBUS pulsing include a pull-down to ground and a pull-up to VDD3.3.

6.7.2.1 SessEnd Comparator

The SessEnd comparator is designed to trip when Vbus is less than 0.5 volts. When Vbus goes below 0.5 volts, the session is considered to be ended and SessEnd will transition from 0 to 1. The SessEnd comparator is disabled when the Suspendn = 0. When disabled, the SessEnd output is 0. The SessEnd comparator trip points are detailed in [Table 5.7](#).

6.7.2.2 SessVId Comparator

The SessVId comparator is used when the PHY is configured as either an A or B device. When configured as an A device, the SessVId is used to detect Session Request protocol (SRP). When configured as a B device, SessVId is used to detect the presence of Vbus. The SessVId comparator is not disabled with Suspendn and its output will always reflect the state of VBUS. The SessVId comparator trip point is detailed in [Table 5.7](#).

Note: The OTG Supplement specifies a voltage range for A-Device Session Valid and B-Device Session Valid comparator. The USB3500 PHY combines the two comparators into one and uses the narrower threshold range.

6.7.2.3 VbusVId Comparator

The final Vbus comparator is the VbusVId comparator. This comparator is only used when configured as an A-device. In the OTG protocol the A-device is responsible to ensure that the VBUS voltage is within a certain range. The VbusVId comparator is disabled when Suspendn = 0. When disabled the VbusVId will read 0. The VbusVId comparator trip points are detailed in [Table 5.7](#).

When the A-device is able to provide 8-100mA, it must ensure Vbus doesn't go below 4.4 volts. If the A-device can provide 100-500mA on VBUS, it must ensure that Vbus does not go below 4.75 volts.

The internal Vbus comparator is designed to ensure that Vbus remains above 4.4 volts. If the design is required to supply over 100mA an external Vbus comparator or overcurrent fault detection should be used.

6.7.2.4 Vbus Pull-up and Pull-down Resistors

In addition to the internal Vbus comparators, the USB3500 also includes the integrated VBUS pull-up and pull-down resistors used for VBUS Pulsing. To discharge the VBUS voltage, so that a Session Request can begin, the USB3500 provides a pull-down resistor from VBUS to Ground. This resistor is controlled by the DISCHRGVBUS pin. The pull-up resistor is connected between VBUS and VDD3.3. This resistor is used to pull Vbus above 2.1 volts to indicate to the A-Device that a USB session has been requested. The state of the pull-up resistor is controlled by the CHRGVBUS pin. The Pull-Up and Pull-Down resistor values are detailed in [Table 5.7](#).

6.7.2.5 Vbus Input Impedance

The OTG Supplement requires an A-Device that supports Session request protocol to have an input impedance less than 100kohm and greater the 40kohm to ground. In addition, if configured as a B-Device, the PHY cannot draw more then 150uA from Vbus. The USB3500 provides a 75k Ω nominal resistance to ground which meets the above requirements.

Chapter 7 Application Notes

The following sections consist of select functional explanations to aid in implementing the USB3500 into a system. For complete description and specifications consult the *USB 2.0 Transceiver Macrocell Interface Specification* and *Universal Serial Bus Specification Revision 2.0*.

7.1 Linestate

The voltage thresholds that the LINESTATE[1:0] signals use to reflect the state of DP and DM depend on the state of XCVRSELECT. LINESTATE[1:0] uses HS thresholds when the HS transceiver is enabled (XCVRSELECT = 0) and FS thresholds when the FS transceiver is enabled (XCVRSELECT = 1). There is not a concept of variable single-ended thresholds in the USB 2.0 specification for HS mode.

The HS receiver is used to detect Chirp J or K, where the output of the HS receiver is always qualified with the Squelch signal. If squelched, the output of the HS receiver is ignored. In the USB3500, as an alternative to using variable thresholds for the single-ended receivers, the following approach is used. In HS device mode, 3ms of no USB activity (IDLE state) signals a reset. The Link monitors LINESTATE[1:0] for the IDLE state. To minimize transitions on LINESTATE[1:0] while in HS mode, the presence of !Squelch is used to force LINESTATE[1:0] to a J state.

Table 7.1 Device Linestate States (DPPD & DMPD = 0)

LINESTATE[1:0]		STATE OF DP/DM LINES		
		FULL SPEED XCVRSELECT[1:0]=01 TERMSELECT=1	HIGH SPEED XCVRSELECT[1:0]=00 TERMSELECT=0	CHIRP MODE XCVRSELECT[1:0]=00 TERMSELECT=1
LS[1]	LS[0]			
0	0	SE0	Squelch	Squelch
0	1	FS-J	!Squelch	!Squelch & HS Differential Receiver Output
1	0	FS-K	Invalid	!Squelch & !HS Differential Receiver Output
1	1	SE1	Invalid	Invalid

Table 7.2 Host Linestate States (DPPD & DMPD = 1)

LINESTATE[1:0]		STATE OF DP/DM LINES			
		LOW SPEED XCVRSEL[1:0]=10 TERMSELECT=1	FULL SPEED XCVRSEL[1:0]=01 TERMSELECT=1	HIGH SPEED XCVRSEL[1:0]=00 TERMSELECT=0 OPMODE=00/01	CHIRP MODE XCVRSEL[1:0]=00 TERMSELECT=0 OPMODE=10
LS[1]	LS[0]				
0	0	SE0	SE0	Squelch	Squelch
0	1	LS-K	FS-J	!Squelch	!Squelch & HS Differential Receiver Output
1	0	LS-J	FS-K	Invalid	!Squelch & !HS Differential Receiver Output

Table 7.2 Host Linestate States (DPPD & DMPD = 1) (continued)

LINESTATE[1:0]		STATE OF DP/DM LINES			
		LOW SPEED XCVRSEL[1:0]=10 TERMSELECT=1	FULL SPEED XCVRSEL[1:0]=01 TERMSELECT=1	HIGH SPEED XCVRSEL[1:0]=00 TERMSELECT=0 OPMODE=00/01	CHIRP MODE XCVRSEL[1:0]=00 TERMSELECT=0 OPMODE=10
LS[1]	LS[0]				
1	1	SE1	SE1	Invalid	Invalid

7.2 OPMODES

The OPMODE[1:0] pins allow control of the operating modes.

Table 7.3 Operational Modes

MODE[1:0]	STATE NAME	DESCRIPTION
00	Normal Operation	Transceiver operates with normal USB data encoding and decoding
01	Non-Driving	Allows the transceiver logic to support a soft disconnect feature which tri-states both the HS and FS transmitters, and removes any termination from the USB making it appear to an upstream port that the device has been disconnected from the bus
10	Disable Bit Stuffing and NRZI encoding	Disables bitstuffing and NRZI encoding logic so that 1's loaded from the DATA bus become 'J's on the DP/DM and 0's become 'K's
11	Reserved	N/A

The OPMODE[1:0] signals are normally changed only when the transmitter and the receiver are quiescent, i.e. when entering a test mode or for a device initiated resume.

When using OPMODE[1:0] = 10, the SYNC and EOP patterns are not transmitted.

The only exception to this is when OPMODE[1:0] is set to 10 while TXVALID has been asserted (the transceiver is transmitting a packet), in order to flag a transmission error. In this case, the USB3500 has already transmitted the SYNC pattern so upon negation of TXVALID the EOP must also be transmitted to properly terminate the packet. Changing the OPMODE[1:0] signals under all other conditions (while the transceiver is transmitting or receiving data) will generate undefined results.

7.3 Test Mode Support

Table 7.4 USB 2.0 Test Modes

USB 2.0 TEST MODES	USB3500 SETUP		
	OPERATIONAL MODE	LINK TRANSMITTED DATA	XCVRSELECT & TERMSELECT
SE0_NAK	State 0	No transmit	HS
J	State 2	All '1's	HS
K	State 2	All '0's	HS
Test_Packet	State 0	Test Packet data	HS

7.4 SE0 Handling

For FS operation, IDLE is a J state on the bus. SE0 is used as part of the EOP or to indicate reset. When asserted in an EOP, SE0 is never asserted for more than 2 bit times. The assertion of SE0 for more than 2.5us is interpreted as a reset by the device operating in FS mode.

For HS operation, IDLE is a SE0 state on the bus. SE0 is also used to reset a HS device. A HS device cannot use the 2.5us assertion of SE0 (as defined for FS operation) to indicate reset since the bus is often in this state between packets. If no bus activity (IDLE) is detected for more than 3ms, a HS device must determine whether the downstream facing port is signaling a suspend or a reset. The following section details how this determination is made. If a reset is signaled, the HS device will then initiate the HS Detection Handshake protocol.

7.5 Reset Detection

If a device in HS mode detects bus inactivity for more than 3ms (T1), it reverts to FS mode. This enables the FS pull-up on the DP line in an attempt to assert a continuous FS J state on the bus. The Link must then check LINESTATE for the SE0 condition. If SE0 is asserted at time T2, then the upstream port is forcing the reset state to the device (i.e., a Driven SE0). The device will then initiate the HS detection handshake protocol.

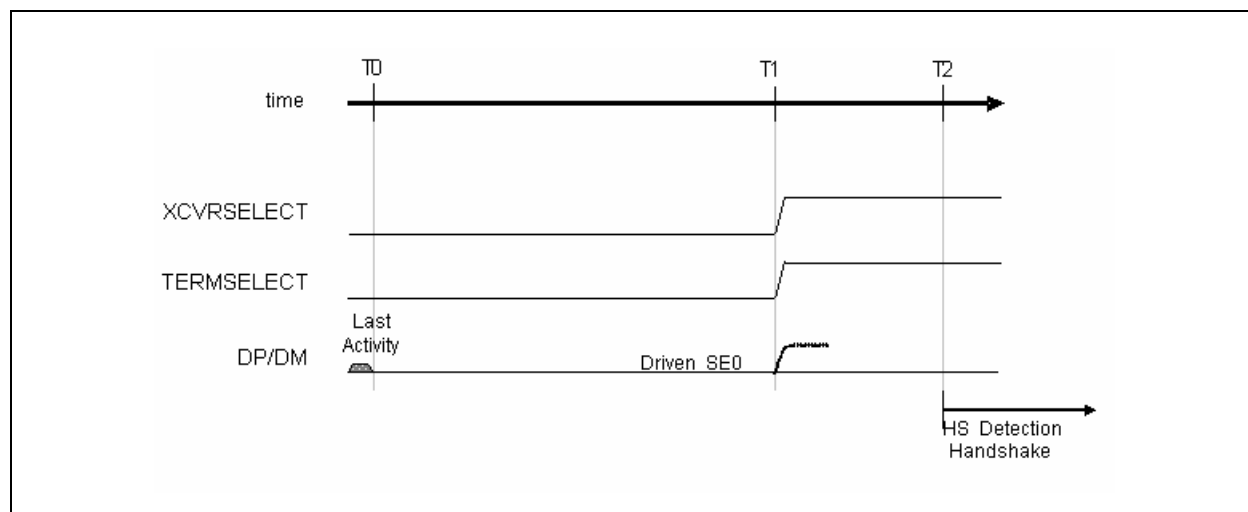

Figure 7.1 Reset Timing Behavior (HS Mode)

Table 7.5 Reset Timing Values (HS Mode)

TIMING PARAMETER	DESCRIPTION	VALUE
HS Reset T0	Bus activity ceases, signaling either a reset or a SUSPEND.	0 (reference)
T1	Earliest time at which the device may place itself in FS mode after bus activity stops.	HS Reset T0 + 3.0ms < T1 < HS Reset T0 + 3.125ms
T2	Link samples LINESTATE. If LINESTATE = SE0, then the SE0 on the bus is due to a Reset state. The device now enters the HS Detection Handshake protocol.	T1 + 100μs < T2 < T1 + 875μs

7.6 Suspend Detection

If a HS device detects SE0 asserted on the bus for more than 3ms (T1), it reverts to FS mode. This enables the FS pull-up on the DP line in an attempt to assert a continuous FS J state on the bus. The Link must then check LINESTATE for the J condition. If J is asserted at time T2, then the upstream port is asserting a soft SE0 and the USB is in a J state indicating a suspend condition. By time T4 the device must be fully suspended.

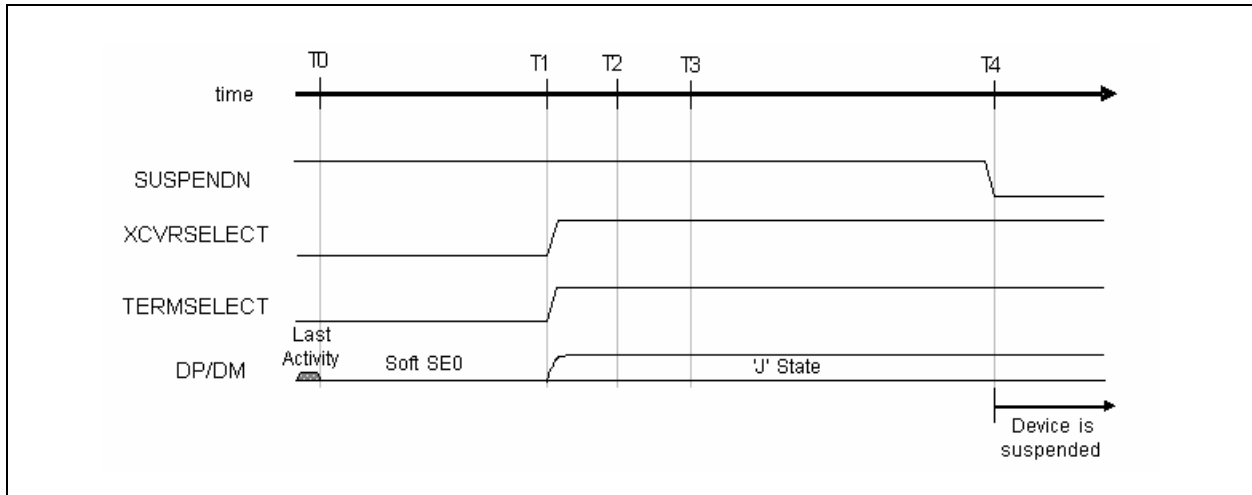

Figure 7.2 Suspend Timing Behavior (HS Mode)

Table 7.6 Suspend Timing Values (HS Mode)

TIMING PARAMETER	DESCRIPTION	VALUE
HS Reset T0	End of last bus activity, signaling either a reset or a SUSPEND.	0 (reference)
T1	The time at which the device must place itself in FS mode after bus activity stops.	$HS\ Reset\ T0 + 3.0ms < T1 < HS\ Reset\ T0 + 3.125ms$
T2	Link samples LINESTATE. If LINESTATE = 'J', then the initial SE0 on the bus (T0 - T1) had been due to a Suspend state and the Link remains in HS mode.	$T1 + 100\ \mu s < T2 < T1 + 875\ \mu s$
T3	The earliest time where a device can issue Resume signaling.	$HS\ Reset\ T0 + 5ms$
T4	The latest time that a device must actually be suspended, drawing no more than the suspend current from the bus.	$HS\ Reset\ T0 + 10ms$

7.7 HS Detection Handshake

The downstream facing port asserting an SE0 state on the bus initiates the HS Detection Handshake.

There are three ways in which a device may enter the HS Handshake Detection process:

1. If the device is suspended and it detects an SE0 state on the bus it may immediately enter the HS handshake detection process.
2. If the device is in FS mode and an SE0 state is detected for more than 2.5 μ s. it may enter the HS handshake detection process.
3. If the device is in HS mode and an SE0 state is detected for more than 3.0ms. it may enter the HS handshake detection process. In HS mode, a device must first determine whether the SE0 state is signaling a suspend or a reset condition. To do this the device reverts to FS mode by placing XCVRSELECT and TERMSELECT into FS mode. The device must not wait more than 3.125ms before the reversion to FS mode. After reverting to FS mode, no less than 100 μ s and no more than 875 μ s later the Link must check the LINESTATE signals. If a J state is detected the device will enter a suspend state. If an SE0 state is detected, then the device will enter the HS Handshake detection process.

In each case, the assertion of the SE0 state on the bus initiates the reset. The minimum reset interval is 10ms. Depending on the previous mode that the bus was in, the delay between the initial assertion of the SE0 state and entering the HS Handshake detection can be from 0 to 4ms.

This transceiver design pushes as much of the responsibility for timing events on to the Link as possible, and the Link requires a stable CLKOUT signal to perform accurate timing. In case 2 and 3 above, CLKOUT has been running and is stable, however in case 1 the USB3500 is reset from a suspend state, and the internal oscillator and clocks of the transceiver are assumed to be powered down. A device has up to 6ms after the release of SUSPENDN to assert a minimum of a 1ms Chirp K.

7.8 HS Detection Handshake – FS Downstream Facing Port

Upon entering the HS Detection process (T0), XCVRSELECT and TERMSELECT are in FS mode. The DP pull-up is asserted and the HS terminations are disabled. The Link then sets OPMODE to *Disable Bit Stuffing and NRZI encoding*, XCVRSELECT to HS mode, and begins the transmission of all 0's data, which asserts a HS K (chirp) on the bus (T1). The device chirp must last at least 1.0ms, and must end no later than 7.0ms after HS Reset T0. At time T1 the device begins listening for a chirp sequence from the host port.

If the downstream facing port is not HS capable, then the HS K asserted by the device is ignored and the alternating sequence of HS Chirp K's and J's is not generated. If no chirps are detected (T4) by the device, it will enter FS mode by returning XCVRSELECT to FS mode.

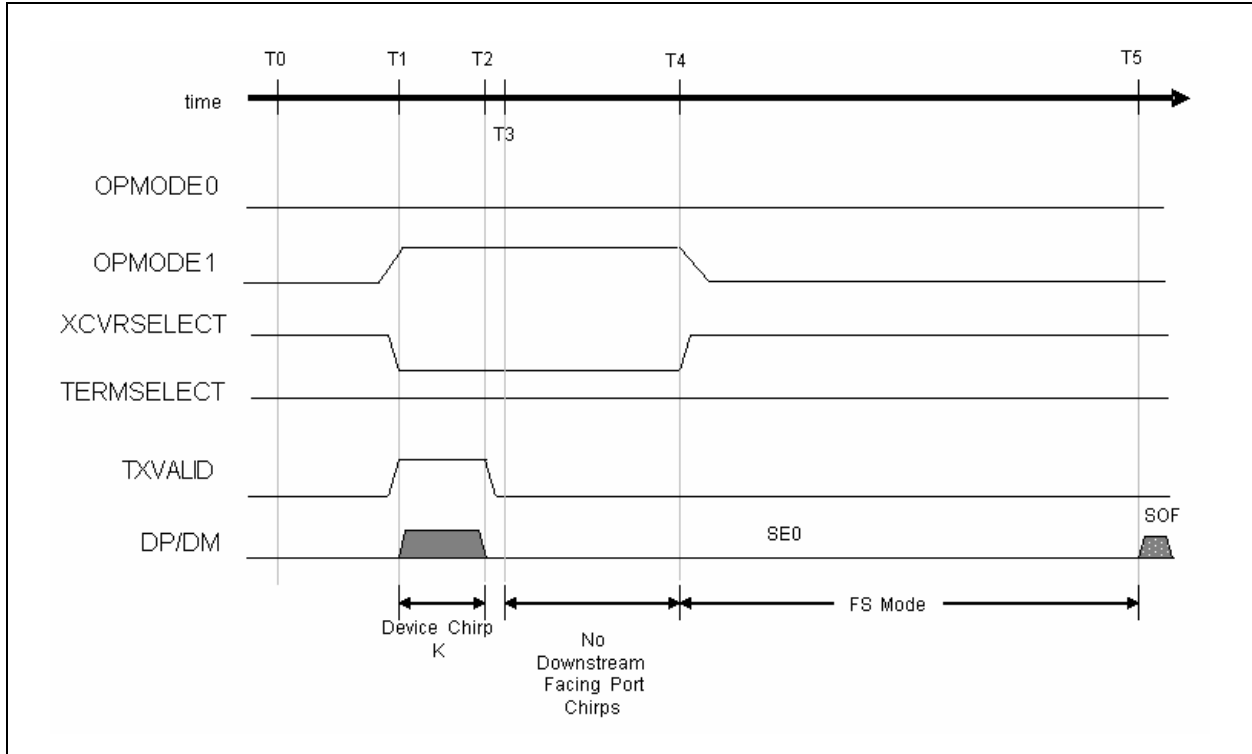
Figure 7.3 HS Detection Handshake Timing Behavior (FS Mode)
Table 7.7 HS Detection Handshake Timing Values (FS Mode)

TIMING PARAMETER	DESCRIPTION	VALUE
T0	HS Handshake begins. DP pull-up enabled, HS terminations disabled.	0 (reference)
T1	Device enables HS Transceiver and asserts Chirp K on the bus.	$T0 < T1 < \text{HS Reset } T0 + 6.0\text{ms}$
T2	Device removes Chirp K from the bus. 1ms minimum width.	$T1 + 1.0 \text{ ms} < T2 < \text{HS Reset } T0 + 7.0\text{ms}$
T3	Earliest time when downstream facing port may assert Chirp KJ sequence on the bus.	$T2 < T3 < T2 + 100\mu\text{s}$
T4	Chirp not detected by the device. Device reverts to FS default state and waits for end of reset.	$T2 + 1.0\text{ms} < T4 < T2 + 2.5\text{ms}$
T5	Earliest time at which host port may end reset	$\text{HS Reset } T0 + 10\text{ms}$

Notes:

- T0 may occur to 4ms after HS Reset T0.
- The Link must assert the Chirp K for 66000 CLKOUT cycles to ensure a 1ms minimum duration.

7.9 HS Detection Handshake – HS Downstream Facing Port

Upon entering the HS Detection process (T0), XCVRSELECT and TERMSELECT are in FS mode. The DP pull-up is asserted and the HS terminations are disabled. The Link then sets OPMODE to *Disable Bit Stuffing and NRZI encoding*, XCVRSELECT to HS mode, and begins the transmission of all 0's data, which asserts a HS K (chirp) on the bus (T1). The device chirp must last at least 1.0ms, and must end no later than 7.0ms after HS Reset T0. At time T1 the device begins listening for a chirp sequence from the downstream facing port. If the downstream facing port is HS capable, then it will begin generating an alternating sequence of Chirp K's and Chirp J's (T3) after the termination of the chirp from the device (T2). After the device sees the valid chirp sequence Chirp K-J-K-J-K-J (T6), it will enter HS mode by setting TERMSELECT to HS mode (T7).

Figure 7.4 provides a state diagram for Chirp K-J-K-J-K-J validation. Prior to the end of reset (T9) the device port must terminate the sequence of Chirp K's and Chirp J's (T8) and assert SE0 (T8-T9). Note that the sequence of Chirp K's and Chirp J's constitutes bus activity.

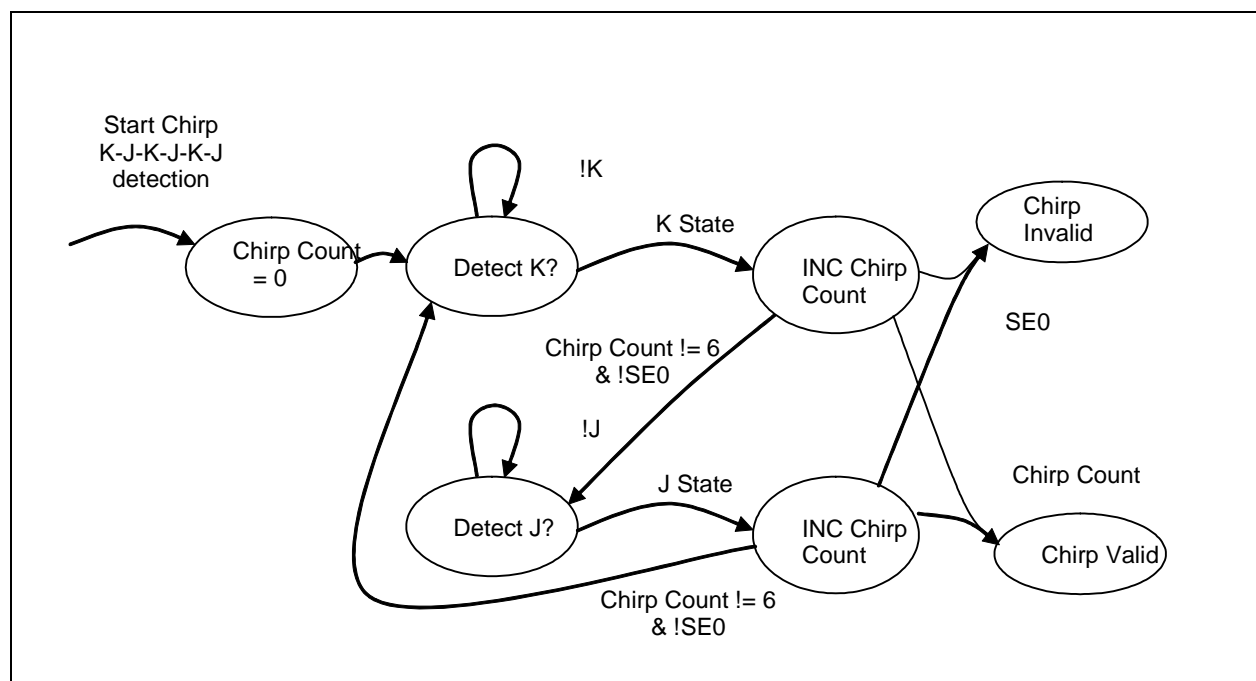
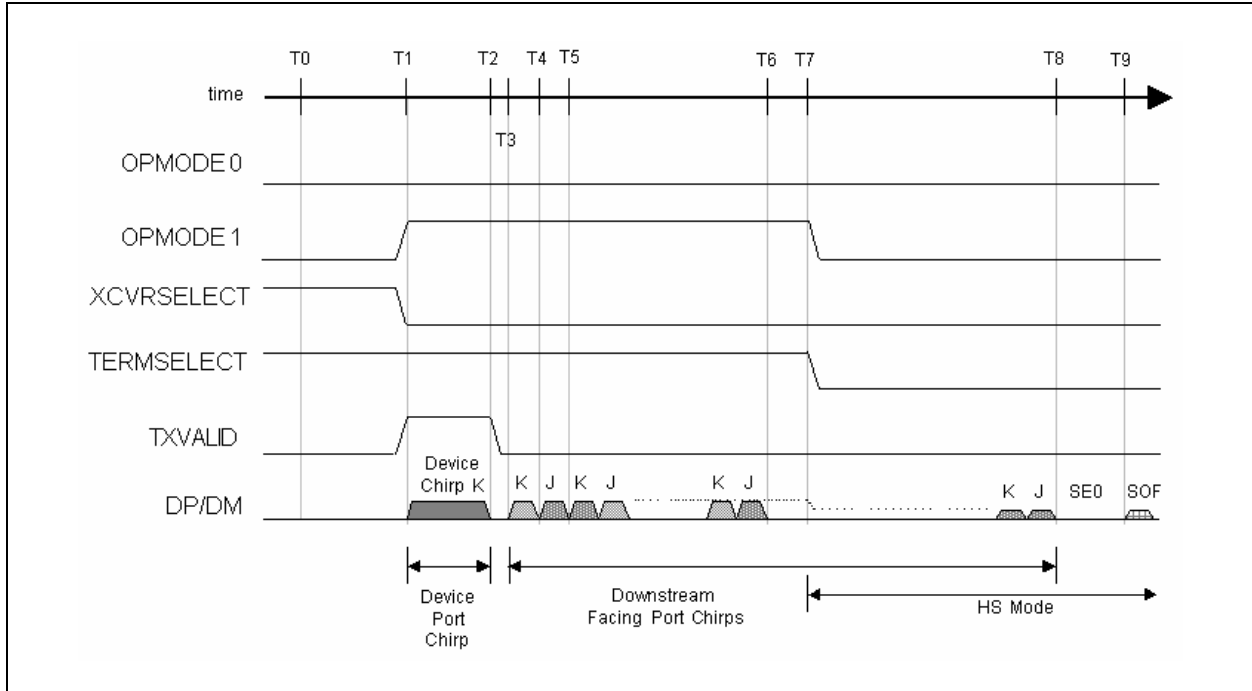

Figure 7.4 Chirp K-J-K-J-K-J Sequence Detection State Diagram

The Chirp K-J-K-J-K-J sequence occurs too slow to propagate through the serial data path, therefore LINESTATE signal transitions must be used by the Link to step through the Chirp K-J-K-J-K-J state diagram, where “K State” is equivalent to LINESTATE = K State and “J State” is equivalent to LINESTATE = J State. The Link must employ a counter (Chirp Count) to count the number of Chirp K and Chirp J states. Note that LINESTATE does not filter the bus signals so the requirement that a bus state must be “continuously asserted for 2.5µs” must be verified by the Link sampling the LINESTATE signals.

Figure 7.5 HS Detection Handshake Timing Behavior (HS Mode)
Table 7.8 Reset Timing Values

TIMING PARAMETER	DESCRIPTION	VALUE
T0	HS Handshake begins. DP pull-up enabled, HS terminations disabled.	0 (reference)
T1	Device asserts Chirp K on the bus.	$T0 < T1 < \text{HS Reset } T0 + 6.0\text{ms}$
T2	Device removes Chirp K from the bus. 1 ms minimum width.	$T0 + 1.0\text{ms} < T2 < \text{HS Reset } T0 + 7.0\text{ms}$
T3	Downstream facing port asserts Chirp K on the bus.	$T2 < T3 < T2 + 100\mu\text{s}$
T4	Downstream facing port toggles Chirp K to Chirp J on the bus.	$T3 + 40\mu\text{s} < T4 < T3 + 60\mu\text{s}$
T5	Downstream facing port toggles Chirp J to Chirp K on the bus.	$T4 + 40\mu\text{s} < T5 < T4 + 60\mu\text{s}$
T6	Device detects downstream port chirp.	T6
T7	Chirp detected by the device. Device removes DP pull-up and asserts HS terminations, reverts to HS default state and waits for end of reset.	$T6 < T7 < T6 + 500\mu\text{s}$
T8	Terminate host port Chirp K-J sequence (Repeating T4 and T5)	$T9 - 500\mu\text{s} < T8 < T9 - 100\mu\text{s}$
T9	The earliest time at which host port may end reset. The latest time, at which the device may remove the DP pull-up and assert the HS terminations, reverts to HS default state.	$\text{HS Reset } T0 + 10\text{ms}$

Datasheet

Notes:

- T0 may be up to 4ms after HS Reset T0.
- The Link must use LINESTATE to detect the downstream port chirp sequence.
- Due to the assertion of the HS termination on the host port and FS termination on the device port, between T1 and T7 the signaling levels on the bus are higher than HS signaling levels and are less than FS signaling levels.

7.10 HS Detection Handshake – Suspend Timing

If reset is entered from a suspended state, the internal oscillator and clocks of the transceiver are assumed to be powered down. [Figure 7.6](#) shows how CLKOUT is used to control the duration of the chirp generated by the device.

When reset is entered from a suspended state (J to SE0 transition reported by LINESTATE), SUSPENDN is combinatorially negated at time T0 by the Link. It takes approximately 5 milliseconds for the transceiver's oscillator to stabilize. The device does not generate any transitions of the CLKOUT signal until it is "usable" (where "usable" is defined as stable to within $\pm 10\%$ of the nominal frequency and the duty cycle accuracy $50\pm 5\%$).

The first transition of CLKOUT occurs at T1. The Link then sets OPMODE to *Disable Bit Stuffing and NRZI encoding*, XCVRSELECT to HS mode, and must assert a Chirp K for 66000 CLKOUT cycles to ensure a 1ms minimum duration. If CLKOUT is 10% fast (66MHz) then Chirp K will be 1.0ms. If CLKOUT is 10% slow (54 MHz) then Chirp K will be 1.2ms. The 5.6ms requirement for the first CLKOUT transition after SUSPENDN, ensures enough time to assert a 1ms Chirp K and still complete before T3. Once the Chirp K is completed (T3) the Link can begin looking for host chirps and use CLKOUT to time the process. At this time, the device follows the same protocol as in [Section 7.9, "HS Detection Handshake – HS Downstream Facing Port"](#) for completion of the High Speed Handshake.

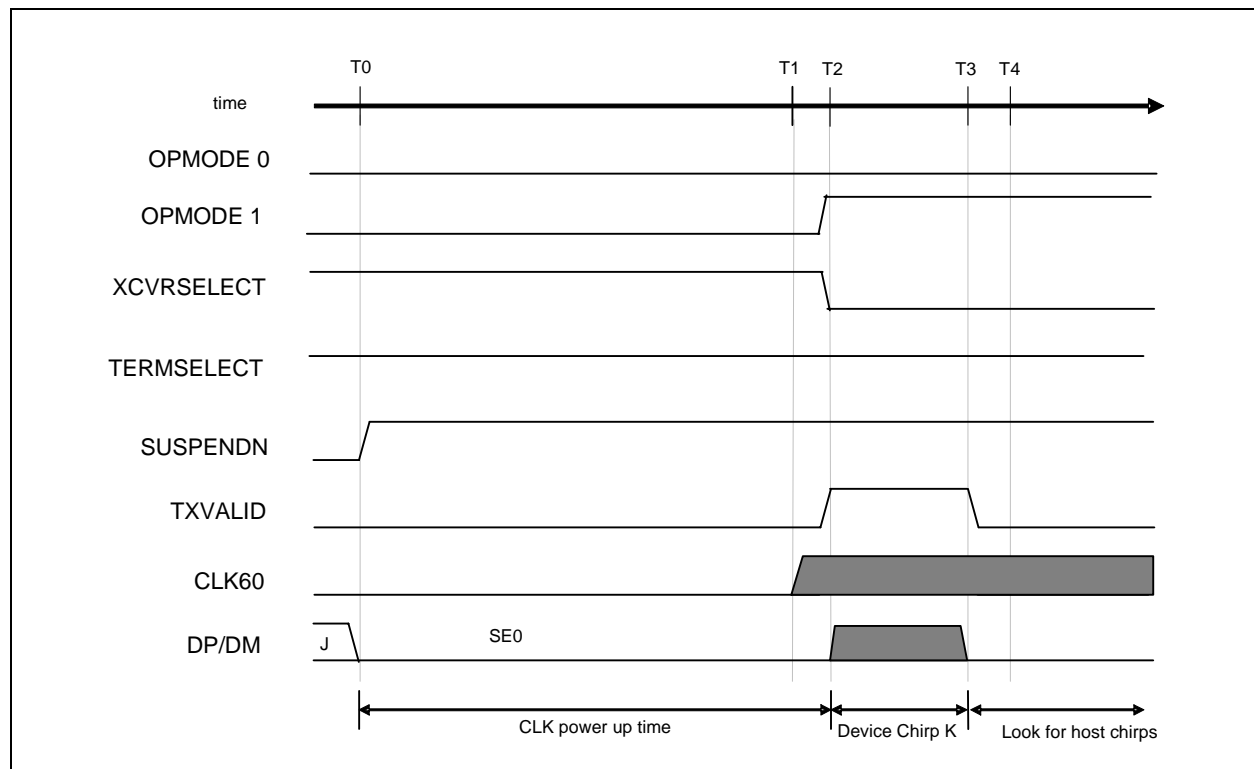

Figure 7.6 HS Detection Handshake Timing Behavior from Suspend

To detect the assertion of the downstream Chirp K's and Chirp J's for 2.5 μ s (T_{FILT}), the Link must see the appropriate LINESTATE signals asserted continuously for 165 CLKOUT cycles.

Table 7.9 HS Detection Handshake Timing Values from Suspend

TIMING PARAMETER	DESCRIPTION	VALUE
T0	While in suspend state an SE0 is detected on the USB. HS Handshake begins. D+ pull-up enabled, HS terminations disabled, SUSPENDN negated.	0 (HS Reset T0)
T1	First transition of CLKOUT. CLKOUT "Usable" (frequency accurate to $\pm 10\%$, duty cycle accurate to 50 ± 5).	$T_0 < T_1 < T_0 + 5.6\text{ms}$
T2	Device asserts Chirp K on the bus.	$T_1 < T_2 < T_0 + 5.8\text{ms}$
T3	Device removes Chirp K from the bus. (1 ms minimum width) and begins looking for host chirps.	$T_2 + 1.0\text{ ms} < T_3 < T_0 + 7.0\text{ ms}$
T4	CLK "Nominal" (CLKOUT is frequency accurate to $\pm 500\text{ ppm}$, duty cycle accurate to 50 ± 5).	$T_1 < T_3 < T_0 + 20.0\text{ms}$

7.11 Assertion of Resume

In this case, an event internal to the device initiates the resume process. A device with remote wake-up capability must wait for at least 5ms after the bus is in the idle state before sending the remote wake-up resume signaling. This allows the hubs to get into their suspend state and prepare for propagating resume signaling.

The device has 10ms where it can draw a non-suspend current before it must drive resume signaling. At the beginning of this period the Link may negate SUSPENDN, allowing the transceiver (and its oscillator) to power up and stabilize.

Figure 7.7 illustrates the behavior of a device returning to HS mode after being suspended. At T4, a device that was previously in FS mode would maintain TERMSELECT and XCVRSELECT high.

To generate resume signaling (FS 'K') the device is placed in the "Disable Bit Stuffing and NRZI encoding" Operational Mode (OPMODE [1:0] = 10), TERMSELECT and XCVRSELECT must be in FS mode, TXVALID asserted, and all 0's data is presented on the DATA bus for at least 1ms ($T_1 - T_2$).

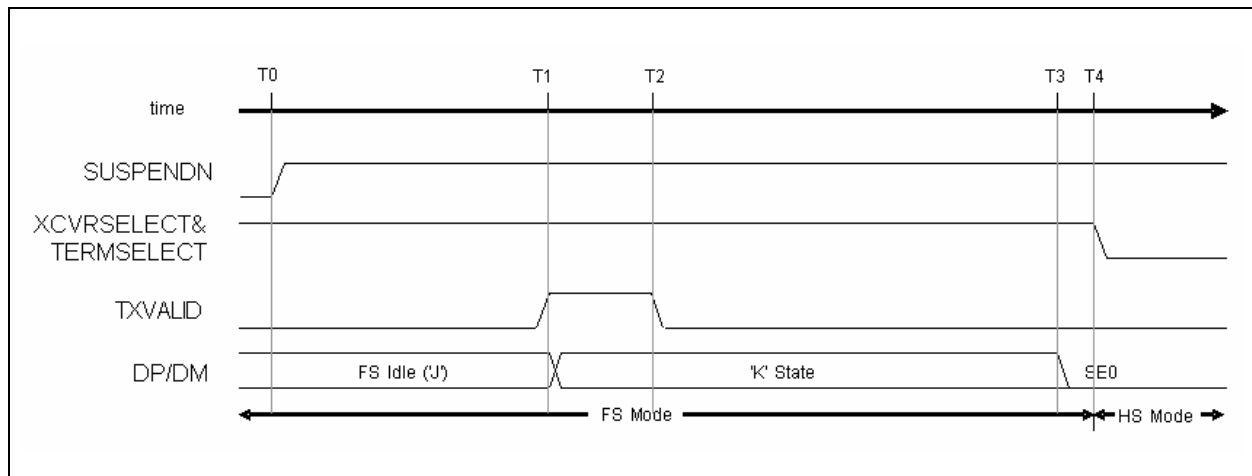

Figure 7.7 Resume Timing Behavior (HS Mode)

Table 7.10 Resume Timing Values (HS Mode)

TIMING PARAMETER	DESCRIPTION	VALUE
T0	Internal device event initiating the resume process	0 (reference)
T1	Device asserts FS 'K' on the bus to signal resume request to downstream port	$T0 < T1 < T0 + 10\text{ms}$.
T2	The device releases FS 'K' on the bus. However by this time the 'K' state is held by downstream port.	$T1 + 1.0\text{ms} < T2 < T1 + 15\text{ms}$
T3	Downstream port asserts SE0.	$T1 + 20\text{ms}$
T4	Latest time at which a device, which was previously in HS mode, must restore HS mode after bus activity stops.	$T3 + 1.33\mu\text{s}$ {2 Low-speed bit times}

7.12 Detection of Resume

Resume signaling always takes place in FS mode (TERMSELECT and XCVRSELECT = FS enabled), so the behavior for a HS device is identical to that of a FS device. The Link uses the LINESTATE signals to determine when the USB transitions from the 'J' to the 'K' state and finally to the terminating FS EOP (SE0 for 1.25 μs -1.5 μs).

The resume signaling (FS 'K') will be asserted for at least 20ms. At the beginning of this period the Link may negate SUSPENDN, allowing the transceiver (and its oscillator) to power up and stabilize.

The FS EOP condition is relatively short. Links that simply look for an SE0 condition to exit suspend mode do not necessarily give the transceiver's clock generator enough time to stabilize. It is recommended that all Link implementations key off the 'J' to 'K' transition for exiting suspend mode (SUSPENDN = 1). And within 1.25 μs after the transition to the SE0 state (low-speed EOP), the Link must enable normal operation, i.e. enter HS or FS mode depending on the mode the device was in when it was suspended.

If the device was in FS mode: then the Link leaves the FS terminations enabled. After the SE0 expires, the downstream port will assert a J state for one low-speed bit time, and the bus will enter a FS Idle state (maintained by the FS terminations).

If the device was in HS mode: then the Link must switch to the FS terminations before the SE0 expires (< 1.25 μs). After the SE0 expires, the bus will then enter a HS IDLE state (maintained by the HS terminations).

7.13 HS Device Attach

Figure 7.8 demonstrates the timing of the USB3500 control signals during a device attach event. When a HS device is attached to an upstream port, power is asserted to the device and the device sets XCVRSELECT and TERMSELECT to FS mode (time T1).

V_{BUS} is the +5V power available on the USB cable. Device Reset in Figure 7.8 indicates that V_{BUS} is within normal operational range as defined in the USB 2.0 specification. The assertion of Device Reset (T0) by the upstream port will initialize the device. By monitoring LINESTATE, the Link state machine knows to set the XCVRSELECT and TERMSELECT signals to FS mode (T1).

The standard FS technique of using a pull-up resistor on DP to signal the attach of a FS device is employed. The Link must then check the LINESTATE signals for SE0. If LINESTATE = SE0 is asserted

at time T2 then the upstream port is forcing the reset state to the device (i.e. Driven SE0). The device will then reset itself before initiating the HS Detection Handshake protocol.

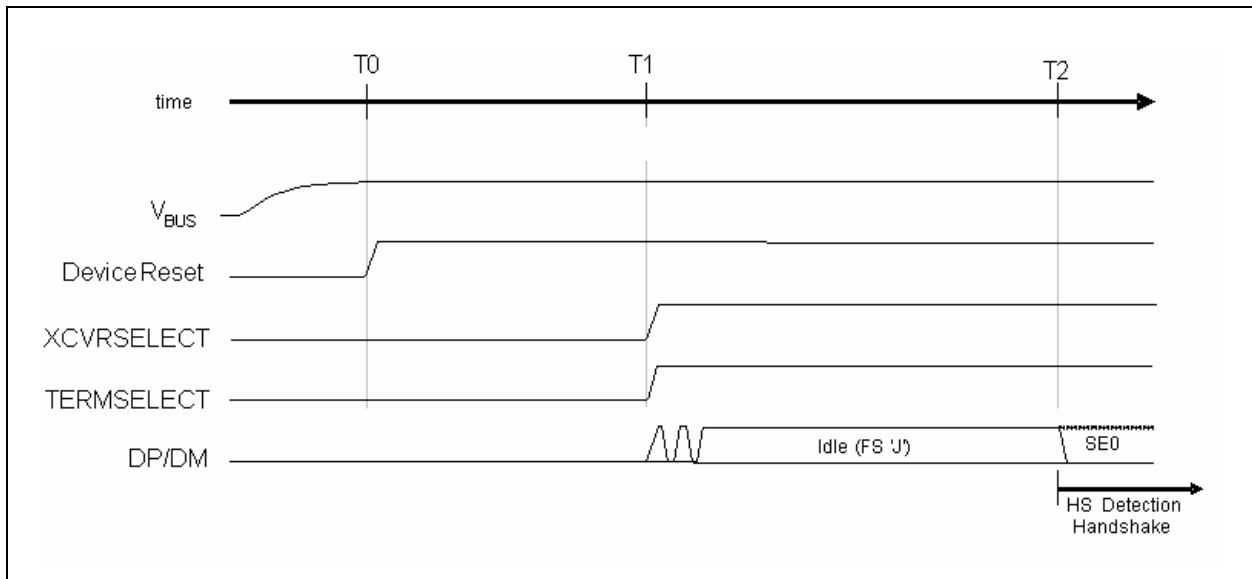

Figure 7.8 Device Attach Behavior

Table 7.11 Attach and Reset Timing Values

TIMING PARAMETER	DESCRIPTION	VALUE
T0	Vbus Valid.	0 (reference)
T1	Maximum time from Vbus valid to when the device must signal attach.	$T0 + 100\text{ms} < T1$
T2 (HS Reset T0)	Debounce interval. The device now enters the HS Detection Handshake protocol.	$T1 + 100\text{ms} < T2$

7.14 USB Reset and Chirp

The USB 2.0 specification describes USB Reset as a means of attaching a FS or a HS Device to a Host. This discussion will focus on a HS device connecting to a HS host.

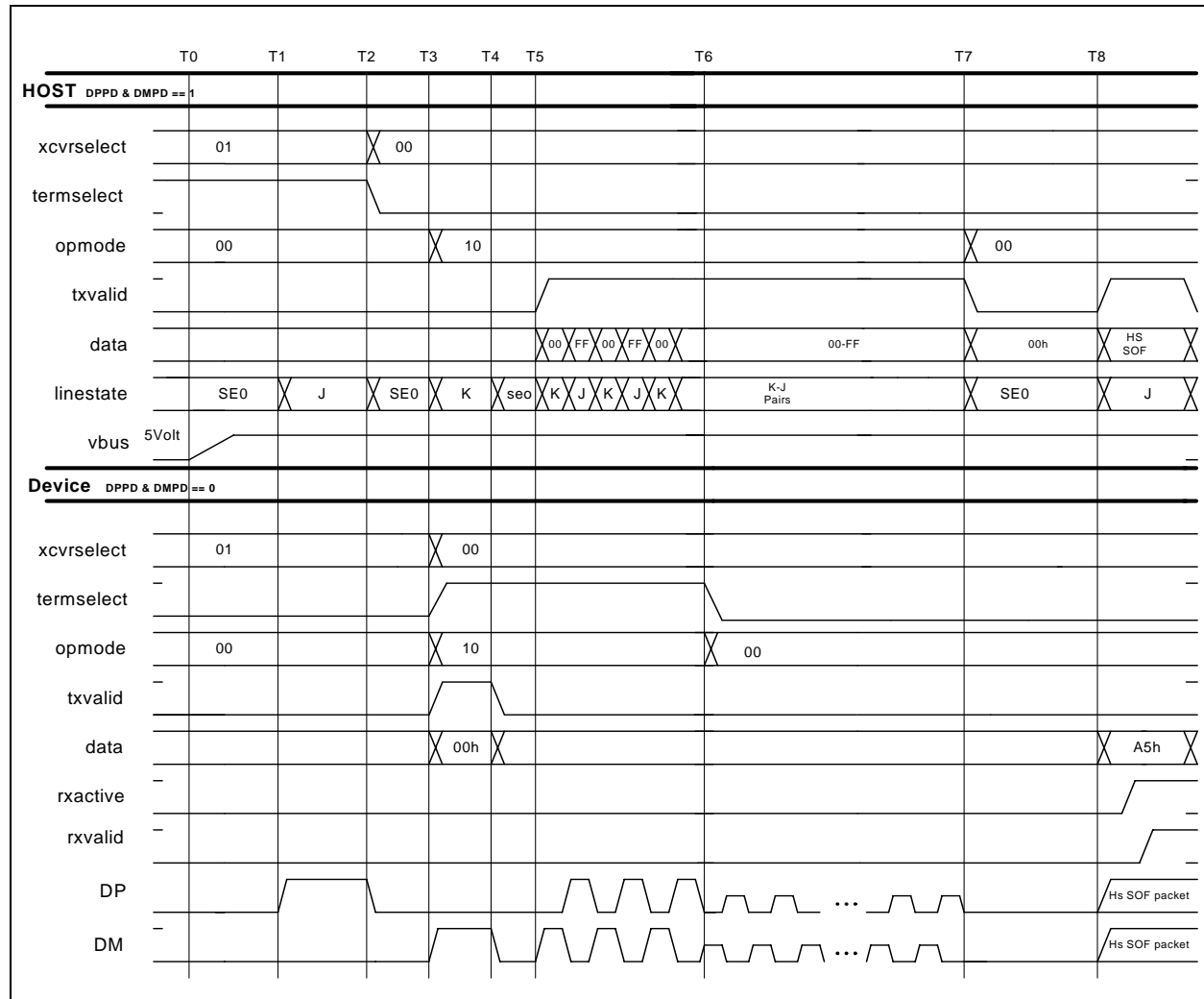

Figure 7.9 USB Reset and Chirp

Figure 7.9 shows the UTMI+ interface for both a Host (DPPD & DMPD = 1) and a Device (DPPD & DMPD = 0). The following discussion applies to when the USB3500 is configured as a Device and is connected to another USB3500 configured as a Host. Since the Host and Device negotiate this transition, both are discussed together and the user may follow this discussion for either a host or device depending on the application of the USB3500. This sequence is also referred to as a “high-speed chirp” due to the K-J pairs which the host sends to the downstream device.

Before the Host begins a session, it will set Xcvrselect to FS mode (10b) and Termselect to 1b to activate the HS termination. The Host will also asserted the 15Kohm pull-down resistors on DP and DM. The 15Kohm pull down resistors will pull DP and DM to 0 volts so that the Host Linestate will return Single Ended Zero (SE0) when nothing is attached.

At time marker T0, the host link applies VBUS to the downstream port.

At T1, the Device has detected a valid voltage on VBUS and has asserted Termselect to enable the 1.5K ohm pull-up resistor on DP. During T1 the Host sees the linestate go from SE0 to a J due to the pull-up on DP.

Note: Note: Should a device attached to the host be a LS device, then the 1.5 K ohm pull-up is applied to DM. The following discussion does not apply to a LS device attached.

At T2, the Host has detected the FS device attached to the USB bus. At this time the Host will reset the bus by driving a SE0. The SE0 is created by switching to HS Mode and activating the HS termination by de-asserting Termselect. The 45 ohm high speed terminations pull the bus to SE0.

At T3, the Device will respond to the SE0 by driving a “Device Chirp K” onto the bus. The “Device Chirp K” is driven with Opmode = 10b so that bitstuffing and NRZI encoding is disabled.

During T3 the HS host will see the “Device Chirp K” and prepare to respond to the device by setting Opmode = 10b to disable the bitstuffing and NRZI encoding.

At T4, the Device will stop driving a the Chirp K, letting the bus return to SE0, and wait for the Host to respond. The device removes the K by de-asserting Txvalid. The device will have driven the K for a minimum of 1mS. The Host sees the linestate change from K to SE0.

At T5, the host begins transmitting K-J pairs to the device. Each K or J is 40-60uS long and the K-J pairs are repeated for the remainder of the 10mS USB reset.

At T6, the device has detected 3 K-J pairs. The device switches the Termselect low and changes Opmode to 00b. The device is now in high speed and waits for the first SOF packet from the upstream host. When Termselect is de-asserted, the HS termination is activated which lowers the amplitude of the K-J pairs.

At T7, the host ends the K-J pairs and switches to normal HS mode by changing Opmode to 00b.

At T8, the Host sends the first SOF packet. This is done by putting the SOF PID 0xA5 on the data bus and asserting Txvalid. The link transfers the SOF packet. After, the SOF packet a normal high speed USB session started.

7.15 Application Diagram

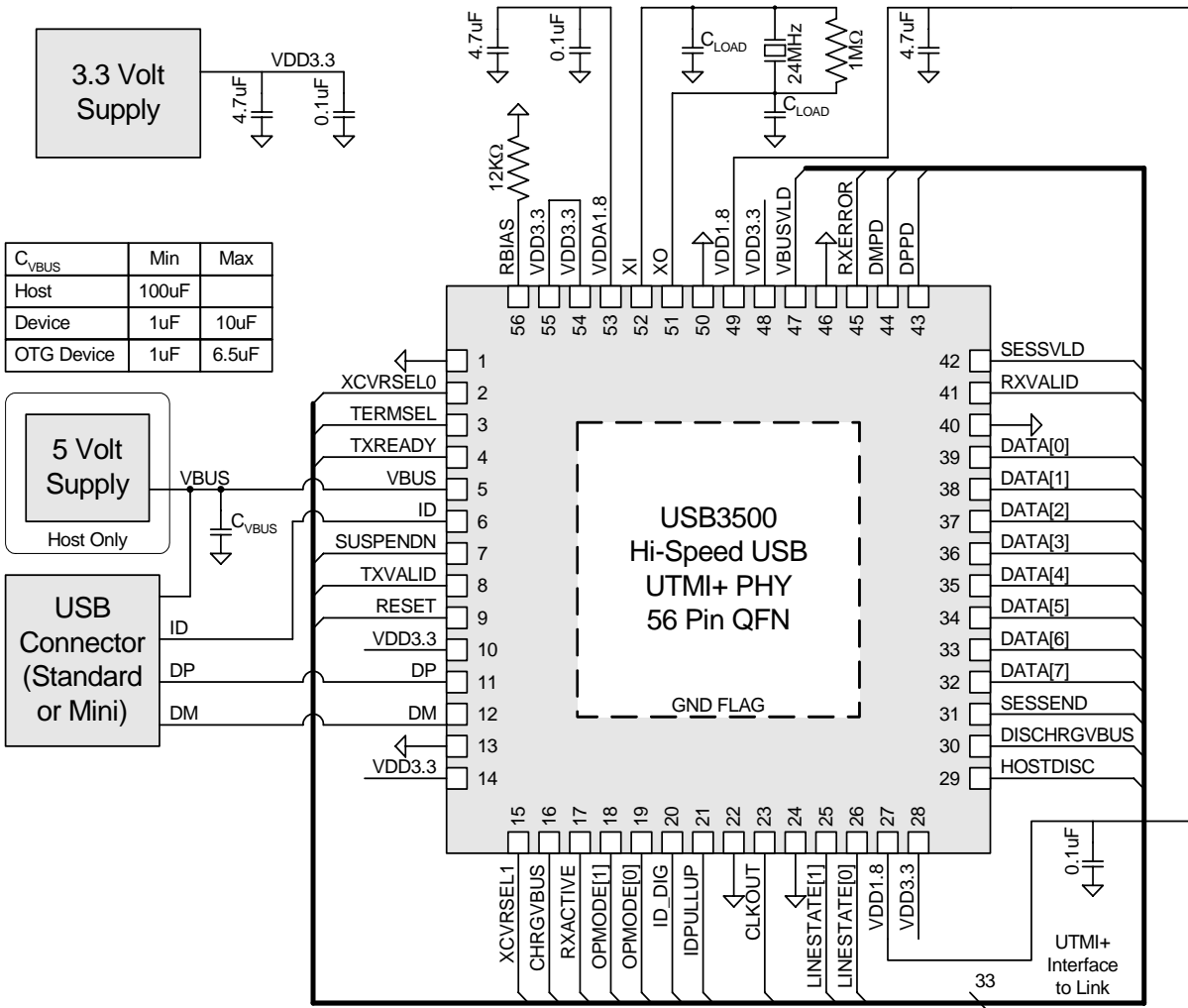

Figure 7.10 USB3500 Application Diagram (Top View)

Chapter 8 Package Outline

The USB3500 is offered in a compact 56 lead QFN package.

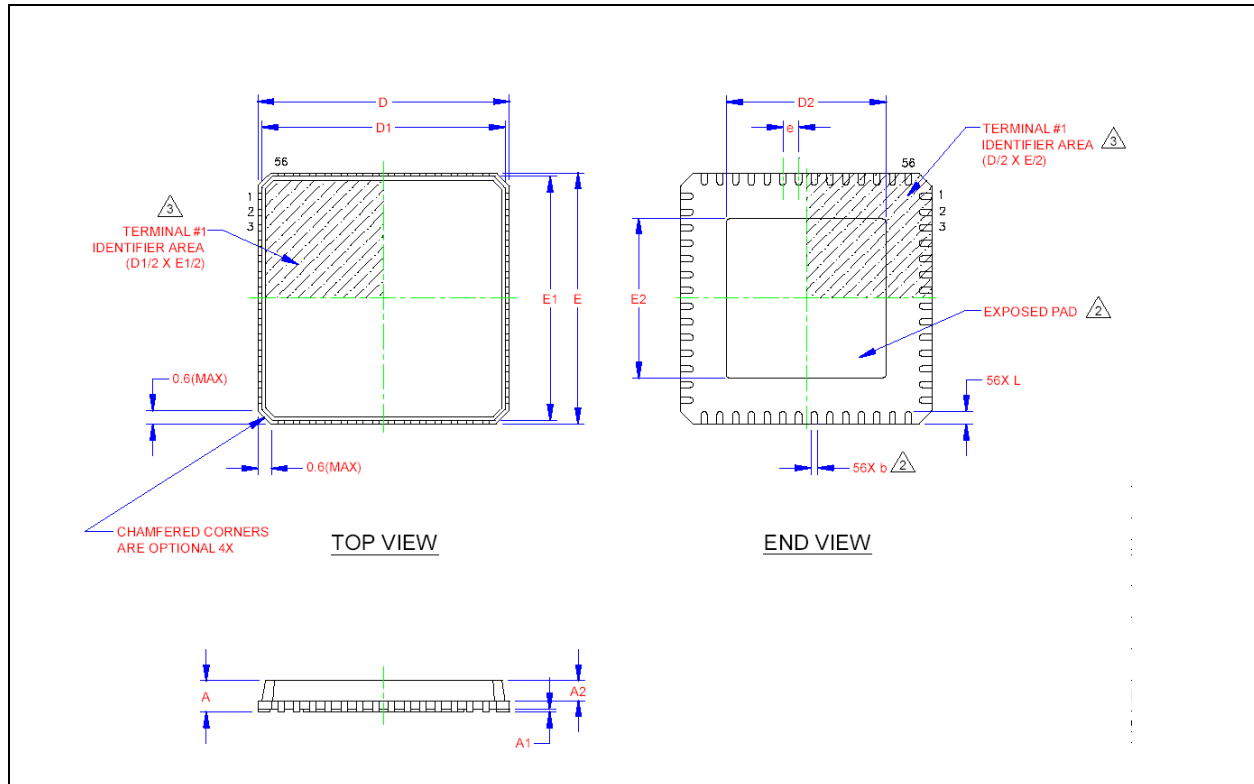

Figure 8.1 USB3500-ABZJ 56 Pin QFN Package Outline, 8 x 8 x 0.9 mm Body (Lead Free)

Table 8.1 56 Terminal QFN Package Parameters

	MIN	NOMINAL	MAX	REMARKS
A	0.70	~	1.00	Overall Package Height
A1	0	0.02	0.05	Standoff
A2	0.60	~	0.90	Mold Thickness
A3		0.20 REF		Copper Lead-frame Substrate
D	7.85	8.00	8.15	X Overall Size
D1	7.55	~	7.95	X Mold Cap Size
D2	2.25	4.5	6.80	X exposed Pad Size
E	7.85	8.00	8.15	Y Overall Size
E1	7.55	~	7.95	Y Mold Cap Size
E2	2.25	4.5	6.80	Y exposed Pad Size
L	0.30	~	0.55	Terminal Length
e		0.50 Basic		Terminal Pitch
b	0.18	~	0.30	Terminal Width

Notes:

- Controlling Unit: millimeter.
- Dimension b applies to plated terminals and is measured between 0.15mm and 0.30mm from the terminal tip. Tolerance on the true position of the leads is ± 0.05 mm at maximum material conditions (MMC).
- Details of terminal #1 identifier are optional but must be located within the zone indicated.

Компания «Океан Электроники» предлагает заключение долгосрочных отношений при поставках импортных электронных компонентов на взаимовыгодных условиях!

Наши преимущества:

- Поставка оригинальных импортных электронных компонентов напрямую с производств Америки, Европы и Азии, а так же с крупнейших складов мира;
- Широкая линейка поставок активных и пассивных импортных электронных компонентов (более 30 млн. наименований);
- Поставка сложных, дефицитных, либо снятых с производства позиций;
- Оперативные сроки поставки под заказ (от 5 рабочих дней);
- Экспресс доставка в любую точку России;
- Помощь Конструкторского Отдела и консультации квалифицированных инженеров;
- Техническая поддержка проекта, помощь в подборе аналогов, поставка прототипов;
- Поставка электронных компонентов под контролем ВП;
- Система менеджмента качества сертифицирована по Международному стандарту ISO 9001;
- При необходимости вся продукция военного и аэрокосмического назначения проходит испытания и сертификацию в лаборатории (по согласованию с заказчиком);
- Поставка специализированных компонентов военного и аэрокосмического уровня качества (Xilinx, Altera, Analog Devices, Intersil, Interpoint, Microsemi, Actel, Aeroflex, Peregrine, VPT, Syfer, Eurofarad, Texas Instruments, MS Kennedy, Miteq, Cobham, E2V, MA-COM, Hittite, Mini-Circuits, General Dynamics и др.);

Компания «Океан Электроники» является официальным дистрибьютором и эксклюзивным представителем в России одного из крупнейших производителей разъемов военного и аэрокосмического назначения «**JONHON**», а так же официальным дистрибьютором и эксклюзивным представителем в России производителя высокотехнологичных и надежных решений для передачи СВЧ сигналов «**FORSTAR**».



JONHON

«**JONHON**» (основан в 1970 г.)

Разъемы специального, военного и аэрокосмического назначения:

(Применяются в военной, авиационной, аэрокосмической, морской, железнодорожной, горно- и нефтедобывающей отраслях промышленности)

«**FORSTAR**» (основан в 1998 г.)

ВЧ соединители, коаксиальные кабели, кабельные сборки и микроволновые компоненты:

(Применяются в телекоммуникациях гражданского и специального назначения, в средствах связи, РЛС, а так же военной, авиационной и аэрокосмической отраслях промышленности).



Телефон: 8 (812) 309-75-97 (многоканальный)

Факс: 8 (812) 320-03-32

Электронная почта: ocean@oceanchips.ru

Web: <http://oceanchips.ru/>

Адрес: 198099, г. Санкт-Петербург, ул. Калинина, д. 2, корп. 4, лит. А