

## DESCRIPTION

Demonstration circuit 894C-C is a 36V-72Vin, synchronous flyback converter featuring the LT3825. This circuit was designed specifically to attain a high current, low ripple, synchronously rectified flyback to efficiently power 12V loads at up to 5A from a typical telecom input voltage range. This circuit features synchronous rectifier drive outputs, output voltage reg-

ulation without the need of an optocoupler, self-starting architecture and input undervoltage lockout.

**Design files for this circuit board are available. Call the LTC factory.**

LT, LTC and LT are registered trademarks of Linear Technology Corporation.

**Table 1. Performance Summary (T<sub>A</sub> = 25°C)**

PARAMETER	CONDITION	VALUE
Minimum Input Voltage		36V
Maximum Input Voltage		72V
Output Voltage V <sub>OUT</sub>	V <sub>IN</sub> = 36V to 72V, I <sub>OUT</sub> = 0A to 5A	12.0V
Maximum Output Current		5A
Typical Output Ripple V <sub>OUT</sub>	V <sub>IN</sub> = 48V, I <sub>OUT</sub> = 5A	< 120mV <sub>p-p</sub>
Output Regulation	Over All Input Voltages and Output Currents	±1%
Load Transient Response	Peak Deviation with Load Step of 3.75A to 5A (10A/us)	±250mV (< ±2.5%)
	Settling Time	100us
Nominal Switching Frequency		200kHz
Efficiency	V <sub>IN</sub> = 48V, I <sub>OUT</sub> = 5A	92.5% Typical

## OPERATING PRINCIPLES

The LT3825 controller exhibits a self-starting capability. When an input voltage is applied, a trickle charge resistor, R8, charges C10 (See Figure 9) to power V<sub>CC</sub>. Then, the IC begins a controlled soft-start of the output voltage. As this voltage begins to rise, V<sub>CC</sub> power is quickly taken over by T1, D2, and R7. When the soft-start period is over, the LT3825 then regulates output voltage by observing the pulses across the auxiliary winding of T1 during the flyback time. The Primary Gate drive (PG) and Synchronous Gate (SG) drive is then Pulse Width

Modulated (PWM) in order to keep the output voltage constant. The synchronous gate drive signal is transmitted to the secondary via the small signal transformer, T2. The output of T2 then drives a discreet gate drive buffer, R26, Q12, and Q13 in order to achieve fast gate transition times, hence a higher efficiency.

The two-stage input filter, C25, L1, and C30 and output filter, C1, C2, L2, and C29 are the reasons that this flyback has exceptionally low conducted emissions.

## QUICK START PROCEDURE

Demonstration circuit 894C-C is easy to set up to evaluate the performance of the LT3825. Refer to Figure 1 for proper measurement equipment setup and follow the procedure below:

**NOTE:** When measuring the input or output voltage ripple, care must be taken to avoid a long ground lead on the oscilloscope probe. Measure the output (or input) voltage ripple by touching the probe tip and probe ground directly across the +Vout and –Vout (or +Vin and –Vin) terminals. See Figure 2 for proper scope probe technique.

1. Set an input power supply that is capable of 36V to 72V at a current of at least 2.5A to a voltage of 36V. Then, turn off the supply.
2. With power off, connect the supply to the input terminals +Vin and –Vin.
  - a. Input voltages lower than 36V can keep the converter from turning on due to the undervoltage lockout feature of the LT3825.
  - b. If efficiency measurements are desired, an ammeter capable of measuring 2.5A<sub>dc</sub> can be put in series with the input supply in order to measure the DC894C-C's input current.
  - c. A voltmeter with a capability of measuring at least 72V can be placed across the input terminals in order to get an accurate input voltage measurement.
3. Turn on the power at the input.

**NOTE:** Make sure that the input voltage never exceeds 72V.
4. Check for the proper output voltage of 12V
5. Turn off the power at the input.
6. Once the proper output voltages are established, connect a variable load capable of sinking 5A at 12V to the output terminals +Vout and –Vout. Set the current for 0A.
  - a. If efficiency measurements are desired, an ammeter or a resistor current shunt that is capable of handling at least 5A<sub>dc</sub> can be put in series with the output load in order to measure the DC894C-C's output current.
  - b. A voltmeter with a capability of measuring at least 12V can be placed across the output terminals in order to get an accurate output voltage measurement.
7. Turn on the power at the input.

**NOTE:** If there is no output, temporarily disconnect the load to make sure that the load is not set too high.
8. Once the proper output voltage is established, adjust the load within the operating range and observe the output voltage regulation, ripple voltage, efficiency and other desired parameters.

# QUICK START GUIDE FOR DEMONSTRATION CIRCUIT 894C-C

## 36V-72VIN, SYNCHRONOUS FLYBACK

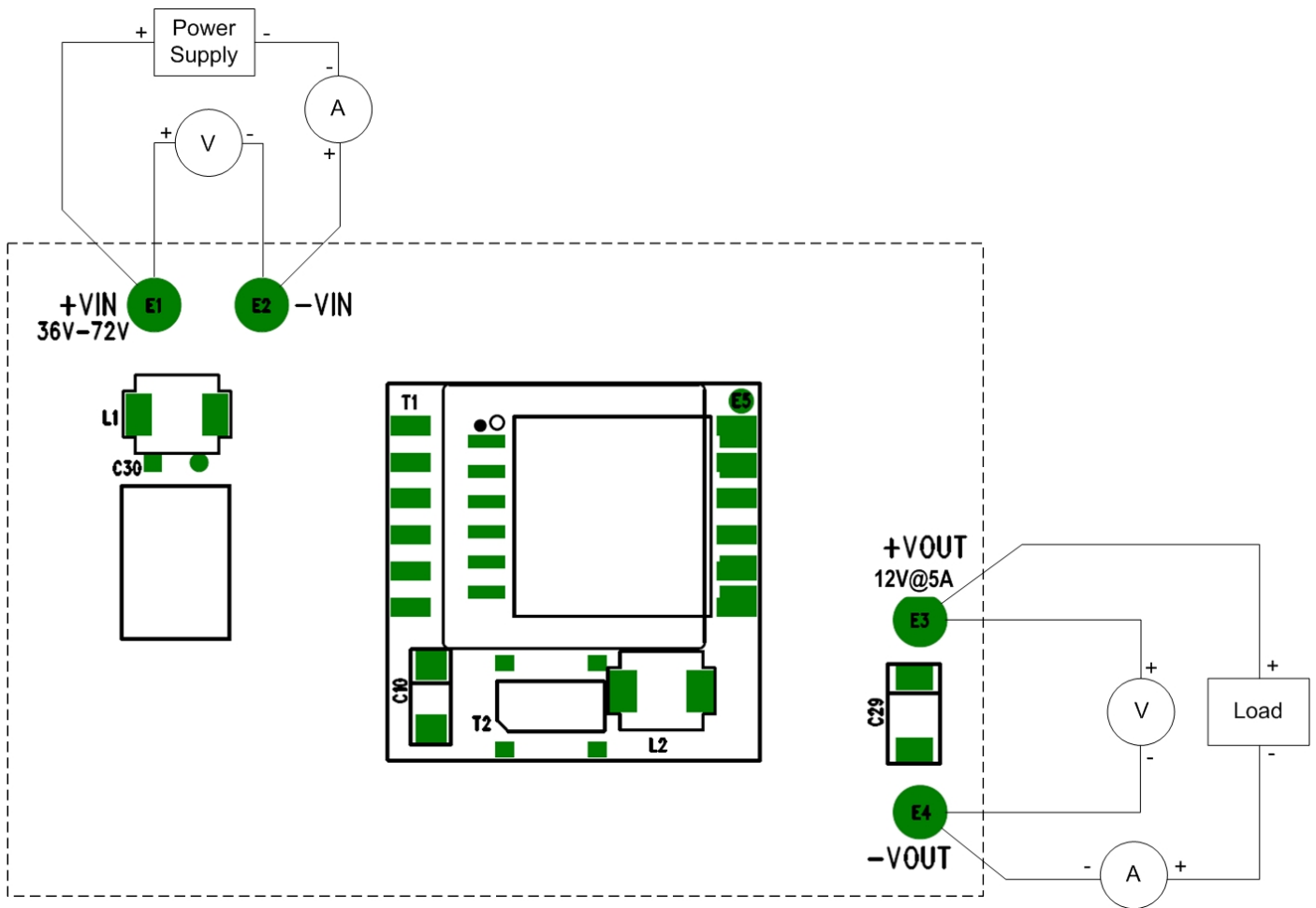

Figure 1. Proper Measurement Equipment Setup

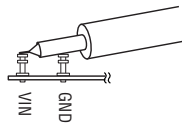

Figure 2. Measuring Input or Output Ripple

## MEASURED DATA

Figures 3 through 8 are measured data for a typical DC894C-C. Figures 9 through 11 are schematics and bill of materials

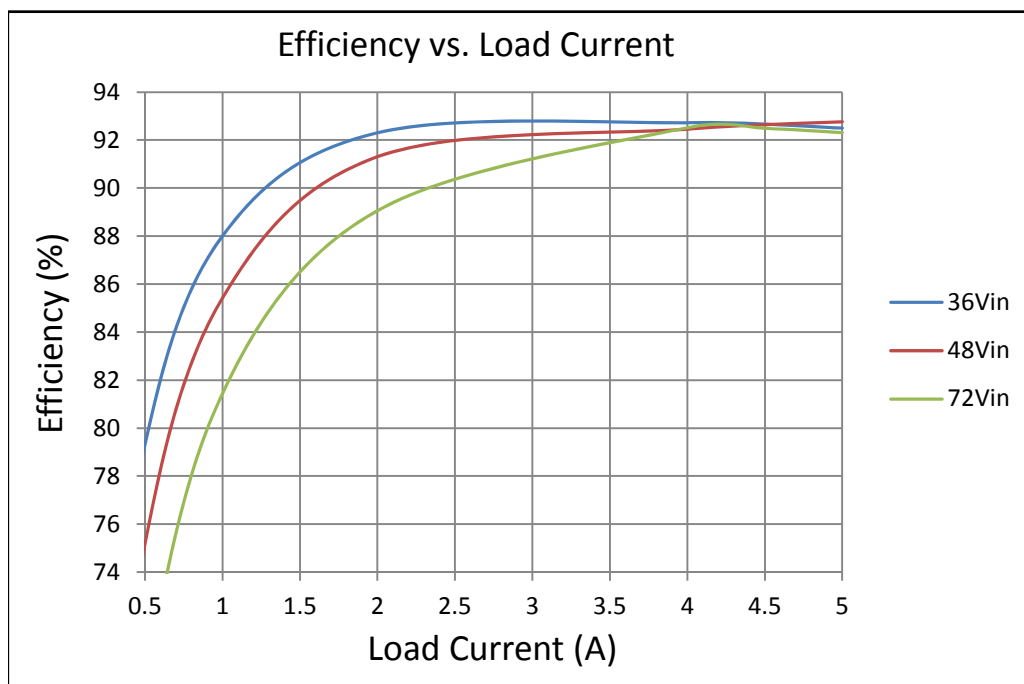

Figure 3. Efficiency

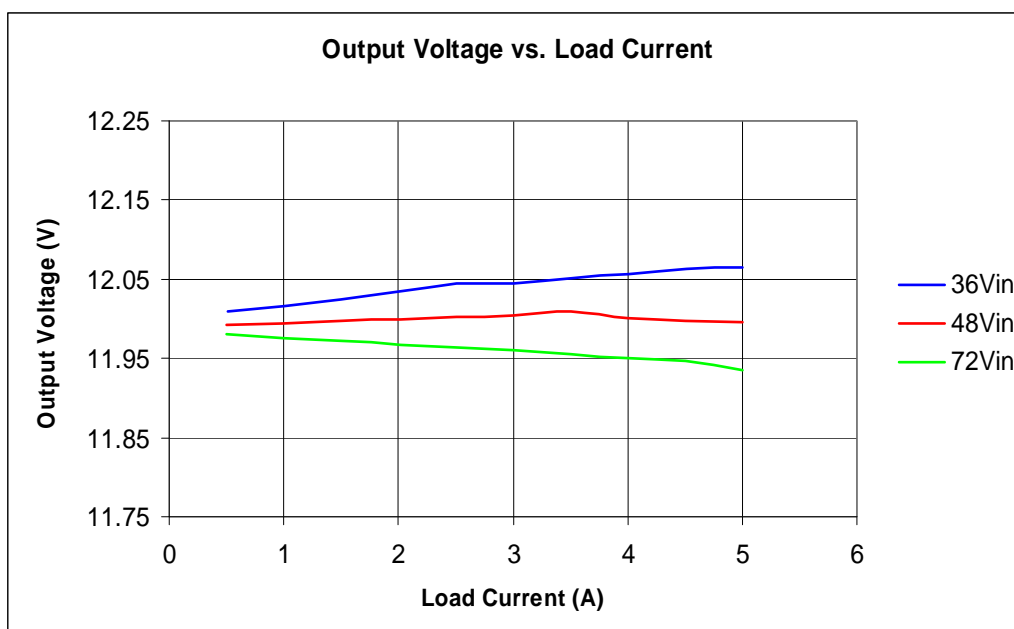

Figure 4. Regulation

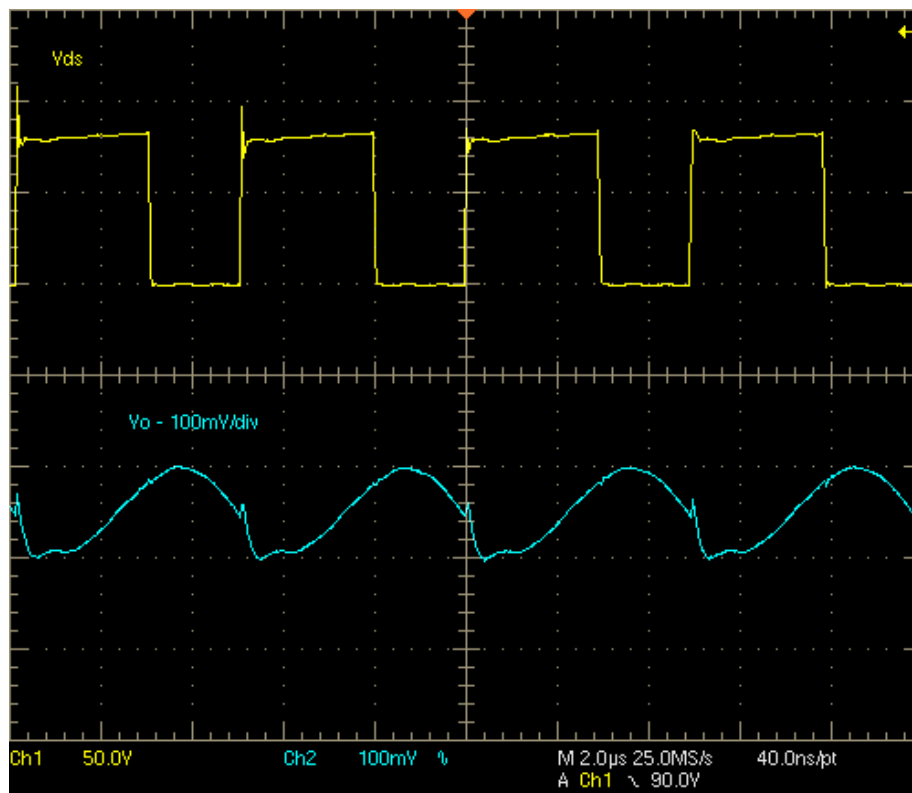

Figure 5. Output Voltage Ripple (48Vin 5A)

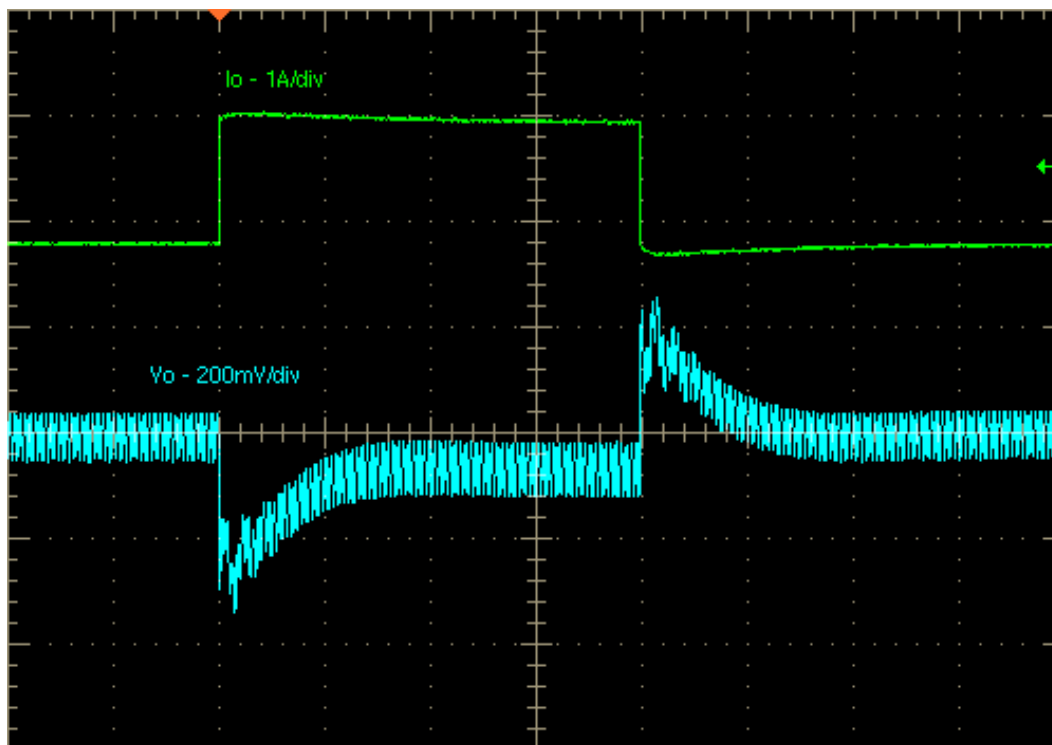

Figure 6. Load Transient Response (10A/us)

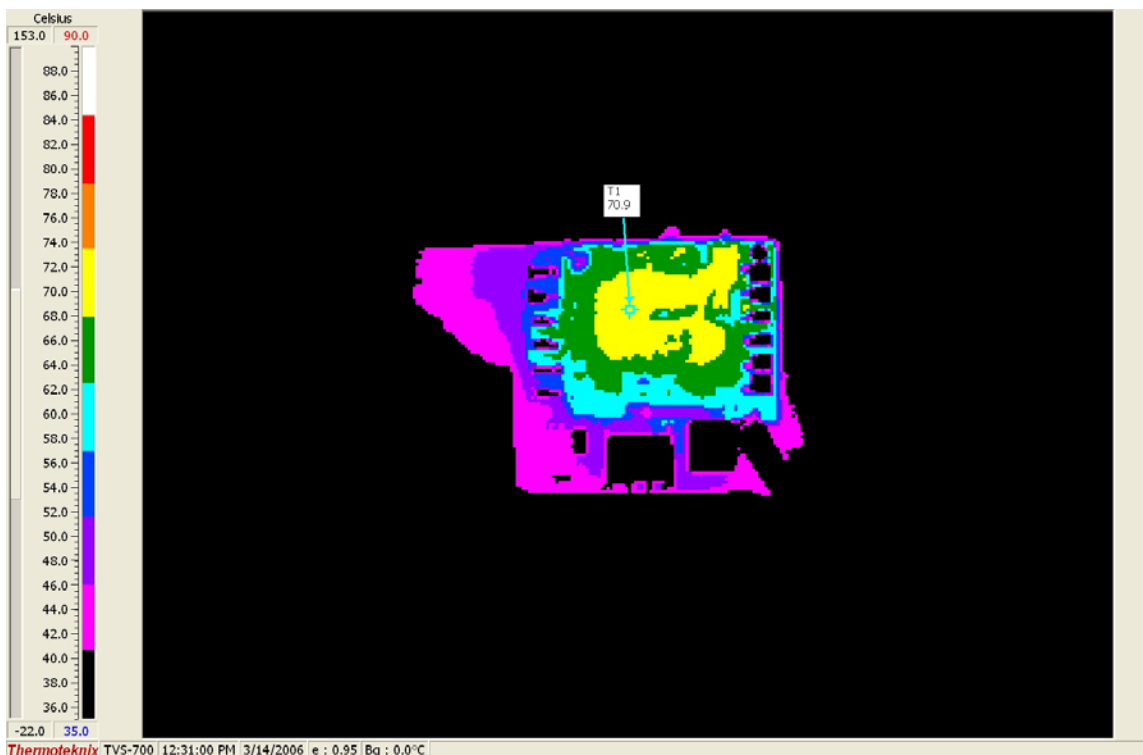

Figure 7. Temp Data (48Vin, 5A, 100LFM airflow – front)



Figure 8. Temp Data (48Vin, 8A, 100LFM airflow – back)

# QUICK START GUIDE FOR DEMONSTRATION CIRCUIT 894C-C

## 36V-72VIN, SYNCHRONOUS FLYBACK

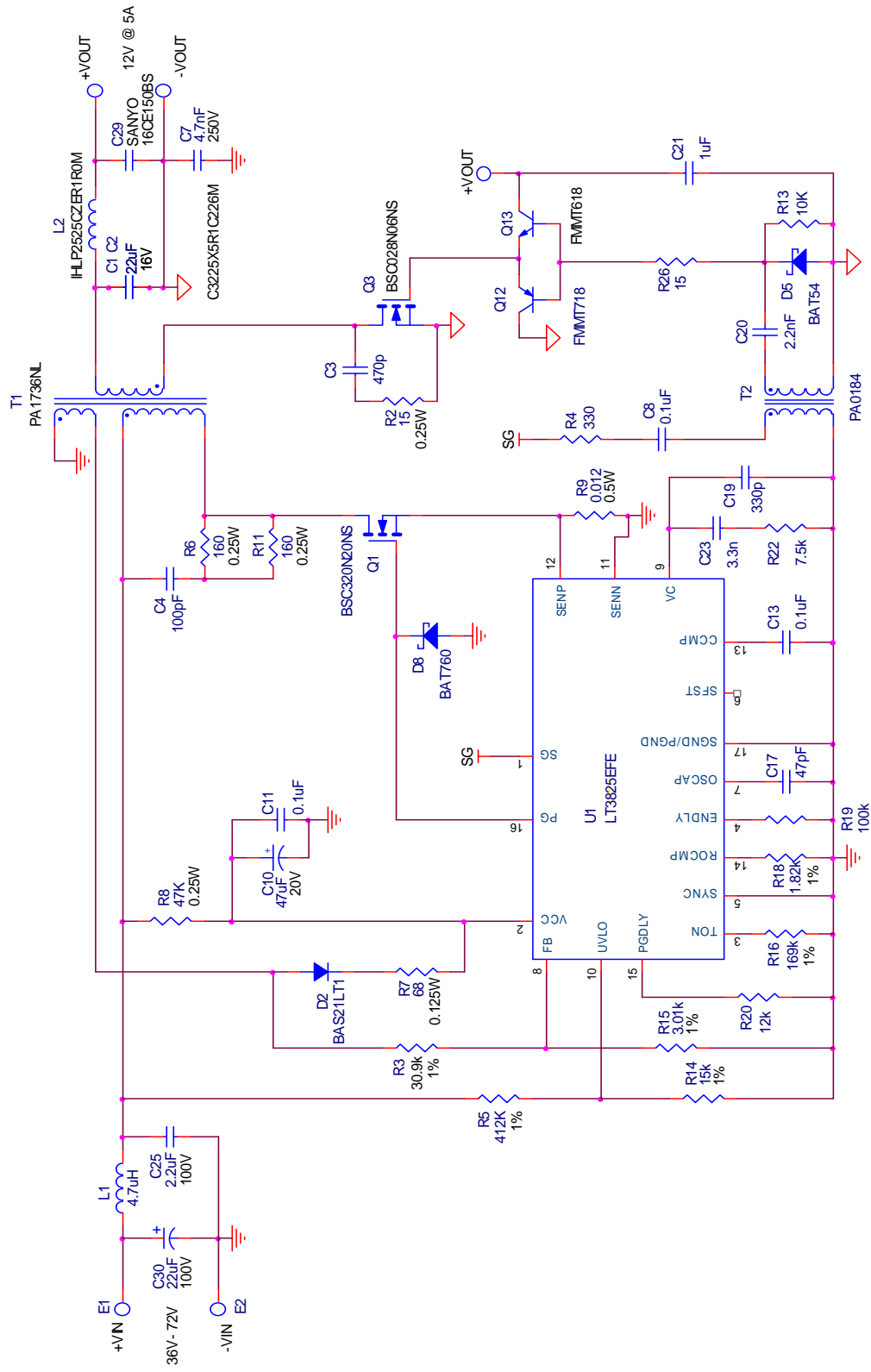

Figure 9. Simplified Schematic

# QUICK START GUIDE FOR DEMONSTRATION CIRCUIT 894C-C

## 36V-72VIN, SYNCHRONOUS FLYBACK

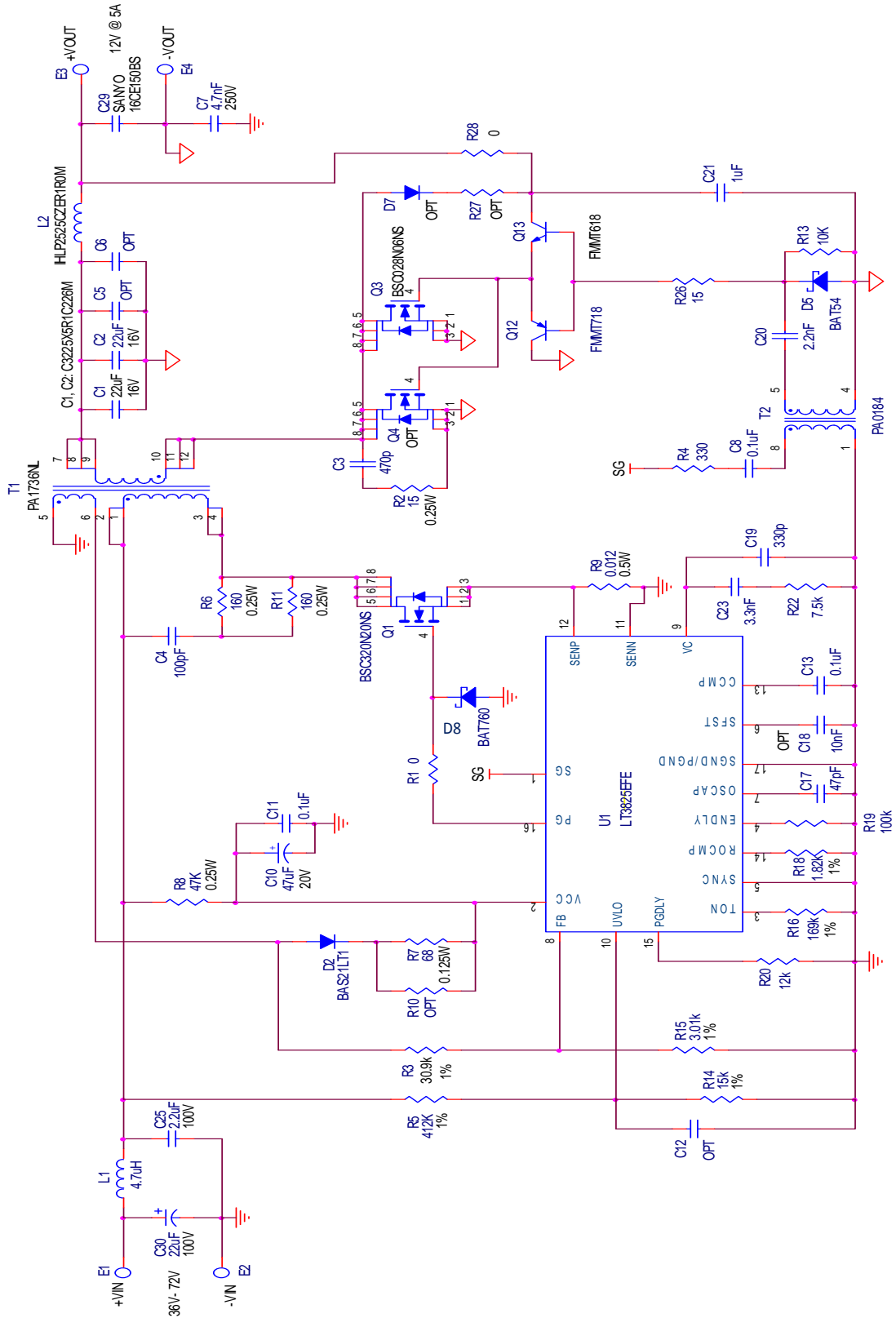

Figure 10. Full Board Schematic



# QUICK START GUIDE FOR DEMONSTRATION CIRCUIT 894C-C

## 36V-72VIN, SYNCHRONOUS FLYBACK

Item	Qty	Ref-Des	Description	Manufacturer's Part Number
<b>REQUIRED CIRCUIT COMPONENTS<sup>1</sup></b>				
1	2	C1,C2	CAP, 1210 22uF 20% 16V X5R	TDK C3225X5R1C226M
2	1	C3	CAP, 1206 470pF 5% 100V COG	AVX 12061A471JAT
3	1	C4	CAP, 1206 100pF 10% 630V COG	TDK C3216COG2J101K
4	1	C7	CAP, 4.7nF 10% 250V X7R	MURATA GA343DR7GD472KW01L
5	3	C8,C11,C13	CAP, 0603 0.1uF 10% 50V X7R	TDK C1608X7R1H104K
6	1	C10	CAP, 6032 47uF 20% 20V TANT	AVX TAJC476M020R
7	0	C12	CAP, 0603 470pF 10% 25V NPO	AVX 06033A471KAT2A OPTION
8	1	C17	CAP, 0603 47pF 10% 25V NPO	AVX 06033A470KAT2A
9	1	C19	CAP, 0603 330pF 5% 50V COG	AVX 06035A331JAT
10	1	C20	CAP, 0603 2.2nF 5% 50V X7R	AVX 06035C222JAT
11	1	C21	CAP, 1206 1uF 20% 25V X7R	AVX 12063C105MAT2A
12	1	C23	CAP, 0603 3.3nF 10% 25V X7R	AVX 06033C332KAT
13	1	C25	CAP, 1812 2.2uF 10% 100V X7R	TDK C4532X7R2A225K
14	1	C29	CAP, 150uF 20% 16V	SANYO 16CE150BS
15	1	D2	DIODE, BAS21-7	DIODES INC. BAS21-7-F
16	1	D5	DIODE, SCHOTTKY	DIODES INC. BAT54-7
17	1	D8	DIODE, SCHOTTKY	DIODES INC. BAT760-7
18	1	L2	IND, 1.0uH	VISHAY IHLP2525CZER1R0M
19	1	Q1	MOSFET, N-CH 200V 36A TDSO8	INFINEON, BSC320N20NS3 G
20	1	Q3	MOSFET N-CH 60V 23A TDSO8	INFINEON, BSC028N06NS
21	1	Q12	XSTR, PNP	ZETEX FMMT718TA
22	1	Q13	XSTR, NPN	ZETEX FMMT618TA
23	1	R2	RES, 1206 15 OHMS 5% 1/4W	VISHAY CRCW120615R0JNEA
24	1	R3	RES, 0603 30.9k OHMS 1% 1/10W	VISHAY CRCW060330K9FKEA
25	1	R4	RES, 0603 330 OHMS 5% 1/10W	VISHAY CRCW0603330RJNEA
26	1	R5	RES, 0603 412K OHMS 1% 1/8W	VISHAY CRCW0603412KFKEA
27	2	R6,R11	RES, 1206 160 OHMS 5% 1/4W	VISHAY CRCW1206160RJNEA
28	1	R7	RES, 0805 68 OHMS 5% 1/8W	VISHAY CRCW080568R0JNEA
29	1	R8	RES, 1206 47K OHMS 5% 1/4W	VISHAY CRCW120647K0JNEA
30	1	R9	RES, 1206 0.012 OHMS 1% 0.5W	IRC LRC-LRF1206LF-01-R012-F
31	1	R13	RES, 0603 10K OHMS 5% 1/10W	VISHAY CRCW060310K0JNEA
32	1	R14	RES, 0603 15K OHMS 1% 1/10W	VISHAY CRCW060315K0FKEA
33	1	R15	RES, 0603 3.01K OHMS 1% 1/10W	VISHAY CRCW06033K01FKEA
34	1	R16	RES, 0603 169K OHMS 1% 1/10W	VISHAY CRCW0603169KFKEA
35	1	R18	RES, 0603 1.82K OHMS 1% 1/10W	VISHAY CRCW06031K82FKEA
36	1	R19	RES, 0603 100K OHMS 5% 1/10W	VISHAY CRCW0603100KJNEA
37	1	R20	RES, 0603 12K OHMS 5% 1/10W	VISHAY CRCW060312K0JNEA
38	1	R22	RES, 0603 7.5K OHMS 5% 1/10W	VISHAY CRCW06037K50JNEA
39	1	R26	RES, 0603 15 OHMS 5% 1/10W	VISHAY CRCW060315R0JNEA
40	1	T1	XFMR, PA1736NL	PULSE PA1736NL
41	1	T2	XFMR, 1.4mH MIN, 50KHz	PULSE PA0184NL
42	1	U1	IC, LT3825EFE	LINEAR TECH LT3825EFE
<b>ADDITIONAL DEMO BOARD CIRCUIT COMPONENTS<sup>2</sup></b>				
43	0	C5	CAP, 1210 OPTION	OPTION
44	0	C6	CAP, 1210 47uF 20% 6.3V X5R OPTION	TDK C3225X5R0J476MT OPTION
45	0	C18	CAP, 0603 10nF 10% 25V X7R OPTION	AVX 06033C103KAT OPTION

# QUICK START GUIDE FOR DEMONSTRATION CIRCUIT 894C-C

## 36V-72VIN, SYNCHRONOUS FLYBACK

---

46	1	C30	CAP, 22uF 100V	SUN ELECTRIC 100ME22AX
47	0	D7	DIODE, OPTION	OPTION
48	1	L1	IND, 4.7uH	VISHAY IHPL2525CZER4R7M01
49	0	Q4	MOSFET N-CH 60V 23A TDSO8	INFINEON, BSC028N06NS OPTION
50	1	R1	RES, 0603 0 OHM JUMPER	VISHAY CRCW06030000Z0EA
51	0	R10	RES, OPTION	OPTION
52	0	R27	RES, OPTION	OPTION
53	1	R28	RES, 0603 0 OHM JUMPER	VISHAY CRCW06030000Z0EA

**Notes:**

1. Required Circuit Components are those parts that are required to implement the circuit function
2. Additional Demo Board Circuit Components are those parts that provide added functionality for the demo board but are or may not be required in the actual circuit.

**Figure 11. Bill of Materials**

Компания «Океан Электроники» предлагает заключение долгосрочных отношений при поставках импортных электронных компонентов на взаимовыгодных условиях!

Наши преимущества:

- Поставка оригинальных импортных электронных компонентов напрямую с производств Америки, Европы и Азии, а так же с крупнейших складов мира;
- Широкая линейка поставок активных и пассивных импортных электронных компонентов (более 30 млн. наименований);
- Поставка сложных, дефицитных, либо снятых с производства позиций;
- Оперативные сроки поставки под заказ (от 5 рабочих дней);
- Экспресс доставка в любую точку России;
- Помощь Конструкторского Отдела и консультации квалифицированных инженеров;
- Техническая поддержка проекта, помощь в подборе аналогов, поставка прототипов;
- Поставка электронных компонентов под контролем ВП;
- Система менеджмента качества сертифицирована по Международному стандарту ISO 9001;
- При необходимости вся продукция военного и аэрокосмического назначения проходит испытания и сертификацию в лаборатории (по согласованию с заказчиком);
- Поставка специализированных компонентов военного и аэрокосмического уровня качества (Xilinx, Altera, Analog Devices, Intersil, Interpoint, Microsemi, Actel, Aeroflex, Peregrine, VPT, Syfer, Eurofarad, Texas Instruments, MS Kennedy, Miteq, Cobham, E2V, MA-COM, Hittite, Mini-Circuits, General Dynamics и др.);

Компания «Океан Электроники» является официальным дистрибьютором и эксклюзивным представителем в России одного из крупнейших производителей разъемов военного и аэрокосмического назначения «JONHON», а так же официальным дистрибьютором и эксклюзивным представителем в России производителя высокотехнологичных и надежных решений для передачи СВЧ сигналов «FORSTAR».



## JONHON

«JONHON» (основан в 1970 г.)

Разъемы специального, военного и аэрокосмического назначения:

(Применяются в военной, авиационной, аэрокосмической, морской, железнодорожной, горно- и нефтедобывающей отраслях промышленности)

«FORSTAR» (основан в 1998 г.)

ВЧ соединители, коаксиальные кабели,  
кабельные сборки и микроволновые компоненты:

(Применяются в телекоммуникациях гражданского и специального назначения, в средствах связи, РЛС, а так же военной, авиационной и аэрокосмической отраслях промышленности).



Телефон: 8 (812) 309-75-97 (многоканальный)

Факс: 8 (812) 320-03-32

Электронная почта: [ocean@oceanchips.ru](mailto:ocean@oceanchips.ru)

Web: <http://oceanchips.ru/>

Адрес: 198099, г. Санкт-Петербург, ул. Калинина, д. 2, корп. 4, лит. А