



RF Power LDMOS Transistors

N-Channel Enhancement-Mode Lateral MOSFETs

These 350 W CW transistors are designed for industrial, scientific and medical (ISM) applications in the 700 to 1300 MHz frequency range. The transistors are capable of 350 W CW or pulse power in narrowband operation.

Typical Performance: $V_{DD} = 50$ Vdc

Frequency (MHz)	Signal Type	G_{ps} (dB)	η_D (%)	P_{out} (W)
1300 ⁽¹⁾	Pulse (100 μ sec, 20% Duty Cycle)	19.2	58.0	350 Peak

Typical Performance: In 915 MHz reference circuit, $V_{DD} = 48$ Vdc

Frequency (MHz)	Signal Type	G_{ps} (dB)	η_D (%)	P_{out} (W)
915	CW	20.7	67.5	355

Load Mismatch/Ruggedness

Frequency (MHz)	Signal Type	VSWR	P_{in} (W)	Test Voltage	Result
1300 ⁽¹⁾	Pulse (100 μ sec, 20% Duty Cycle)	> 20:1 at all Phase Angles	9.6 Peak (3 dB Overdrive)	50	No Device Degradation

1. Measured in 1300 MHz pulse narrowband test circuit.

Features

- Internally input matched for ease of use
- Device can be used single-ended or in a push-pull configuration
- Qualified up to a maximum of 50 V_{DD} operation
- Suitable for linear applications with appropriate biasing
- Integrated ESD protection

Typical Applications

- 915 MHz industrial heating/welding systems
- 1300 MHz particle accelerators
- 900 MHz TETRA base stations

MRF8VP13350N
MRF8VP13350GN

700–1300 MHz, 350 W CW, 50 V
RF POWER LDMOS TRANSISTORS

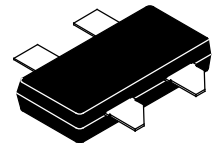

OM-780-4L
PLASTIC
MRF8VP13350N

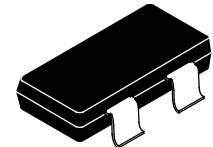

OM-780G-4L
PLASTIC
MRF8VP13350GN

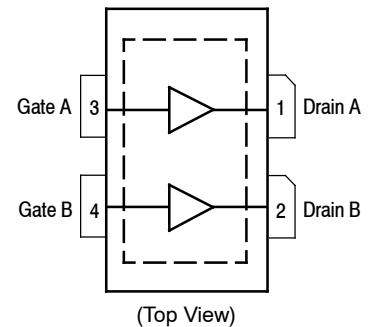

Note: Exposed backside of the package is the source terminal for the transistor.

Figure 1. Pin Connections

Table 1. Maximum Ratings

Rating	Symbol	Value	Unit
Drain-Source Voltage	V_{DS}	-0.5, +100	Vdc
Gate-Source Voltage	V_{GS}	-6.0, +10	Vdc
Storage Temperature Range	T_{stg}	-65 to +150	°C
Case Operating Temperature Range	T_C	-40 to +150	°C
Operating Junction Temperature Range (1,2)	T_J	-40 to +225	°C

Table 2. Thermal Characteristics

Characteristic	Symbol	Value (2,3)	Unit
Thermal Resistance, Junction to Case CW: Case Temperature 93°C, 350 W CW, 50 Vdc, $I_{DQ(A+B)} = 100$ mA, 915 MHz	$R_{\theta JC}$	0.24	°C/W
Thermal Impedance, Junction to Case Pulse: Case Temperature 76°C, 350 W Peak, 100 μ sec Pulse Width, 20% Duty Cycle, 50 Vdc, $I_{DQ(A+B)} = 100$ mA, 1300 MHz	$Z_{\theta JC}$	0.04	°C/W

Table 3. ESD Protection Characteristics

Test Methodology	Class
Human Body Model (per JESD22-A114)	1C, passes 1500 V
Machine Model (per EIA/JESD22-A115)	A, passes 100 V
Charge Device Model (per JESD22-C101)	IV, passes 2000 V

Table 4. Moisture Sensitivity Level

Test Methodology	Rating	Package Peak Temperature	Unit
Per JESD22-A113, IPC/JEDEC J-STD-020	3	260	°C

Table 5. Electrical Characteristics ($T_A = 25^\circ\text{C}$ unless otherwise noted)

Characteristic	Symbol	Min	Typ	Max	Unit
----------------	--------	-----	-----	-----	------

Off Characteristics (4)

Zero Gate Voltage Drain Leakage Current ($V_{DS} = 100$ Vdc, $V_{GS} = 0$ Vdc)	I_{DSS}	—	—	10	μ Adc
Zero Gate Voltage Drain Leakage Current ($V_{DS} = 48$ Vdc, $V_{GS} = 0$ Vdc)	I_{DSS}	—	—	1	μ Adc
Gate-Source Leakage Current ($V_{GS} = 5$ Vdc, $V_{DS} = 0$ Vdc)	I_{GSS}	—	—	1	μ Adc

On Characteristics

Gate Threshold Voltage (4) ($V_{DS} = 10$ Vdc, $I_D = 460$ μ Adc)	$V_{GS(th)}$	1.3	1.9	2.3	Vdc
Gate Quiescent Voltage ($V_{DD} = 50$ Vdc, $I_{DQ(A+B)} = 100$ mAdc, Measured in Functional Test)	$V_{GS(Q)}$	1.7	2.2	2.7	Vdc
Drain-Source On-Voltage (4) ($V_{GS} = 10$ Vdc, $I_D = 1.3$ Adc)	$V_{DS(on)}$	0.1	0.21	0.3	Vdc

1. Continuous use at maximum temperature will affect MTTF.

2. MTTF calculator available at <http://www.nxp.com/RF/calculators>.

3. Refer to AN1955, *Thermal Measurement Methodology of RF Power Amplifiers*. Go to <http://www.nxp.com/RF> and search for AN1955.

4. Each side of device measured separately.

(continued)

Table 5. Electrical Characteristics ($T_A = 25^\circ\text{C}$ unless otherwise noted) (continued)

Characteristic	Symbol	Min	Typ	Max	Unit
Functional Tests ^(1,2) (In NXP Narrowband Test Fixture, 50 ohm system) $V_{DD} = 50\text{ Vdc}$, $I_{DQ(A+B)} = 100\text{ mA}$, $P_{out} = 350\text{ W Peak}$ (70 W Avg.), $f = 1300\text{ MHz}$, 100 μsec Pulse Width, 20% Duty Cycle					
Power Gain	G_{ps}	17.5	19.2	20.5	dB
Drain Efficiency	η_D	55.0	58.0	—	%

Table 6. Load Mismatch/Ruggedness (In NXP Test Fixture, 50 ohm system) $I_{DQ(A+B)} = 100\text{ mA}$

Frequency (MHz)	Signal Type	VSWR	P_{in} (W)	Test Voltage, V_{DD}	Result
1300	Pulse (100 μsec , 20% Duty Cycle)	> 20:1 at all Phase Angles	9.6 Peak (3 dB Overdrive)	50	No Device Degradation

Table 7. Ordering Information

Device	Tape and Reel Information	Package
MRF8VP13350NR3	R3 Suffix = 250 Units, 32 mm Tape Width, 13-inch Reel	OM-780-4L
MRF8VP13350GNR3		OM-780G-4L

1. Part internally input matched.
2. Measurement made with device in straight lead configuration before any lead forming operation is applied. Lead forming is used for gull wing (GN) parts.

TYPICAL CHARACTERISTICS

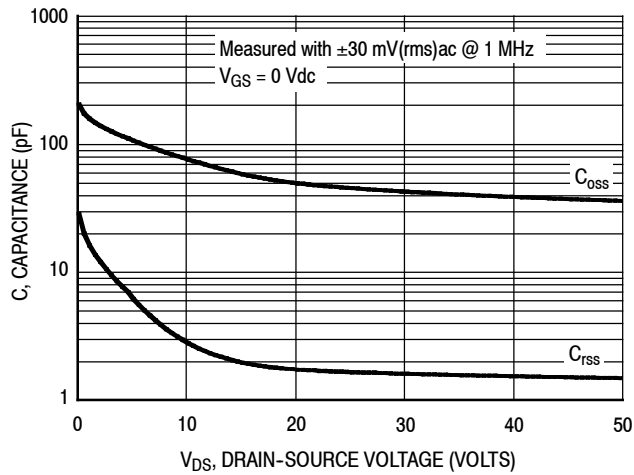

Note: Each side of device measured separately.

Figure 2. Capacitance versus Drain-Source Voltage

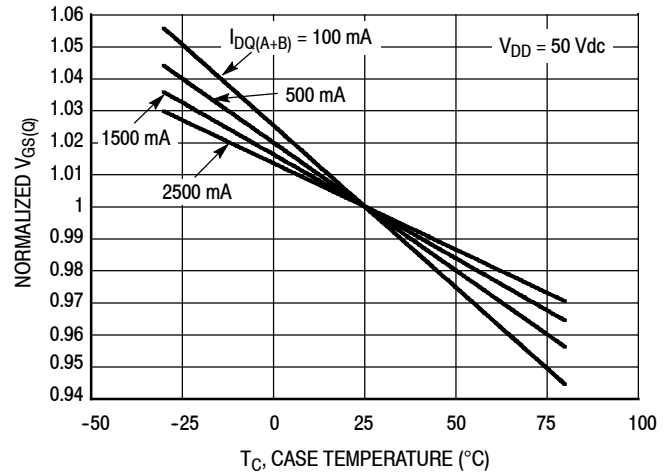

I_{DQ} (mA)	Slope (mV/ $^{\circ}C$)
100	-2.216
500	-1.894
1500	-1.648
2500	-1.420

Figure 3. Normalized V_{GS} versus Quiescent Current and Case Temperature

915 MHz REFERENCE CIRCUIT — 5" x 4" (12.7 cm x 10.2 cm)

Table 8. 915 MHz Performance (In NXP Reference Circuit, 50 ohm system)

$V_{DD} = 48 \text{ Vdc}$, $I_{DQ(A+B)} = 100 \text{ mA}$, $T_C = 25^\circ\text{C}$

Frequency (MHz)	P_{in} (W)	G_{ps} (dB)	η_D (%)	P_{out} (W)
902	3.5	20.1	64.7	359
915	3.0	20.7	67.5	355
928	3.5	20.1	68.7	361

Table 9. Load Mismatch/Ruggedness (In NXP Reference Circuit)

Frequency (MHz)	Signal Type	VSWR	P_{in} (W)	Test Voltage, V_{DD}	Result
915	CW	> 10:1 at all Phase Angles	9.0 (3 dB Overdrive)	48	No Device Degradation

915 MHz REFERENCE CIRCUIT — 5" x 4" (12.7 cm x 10.2 cm)

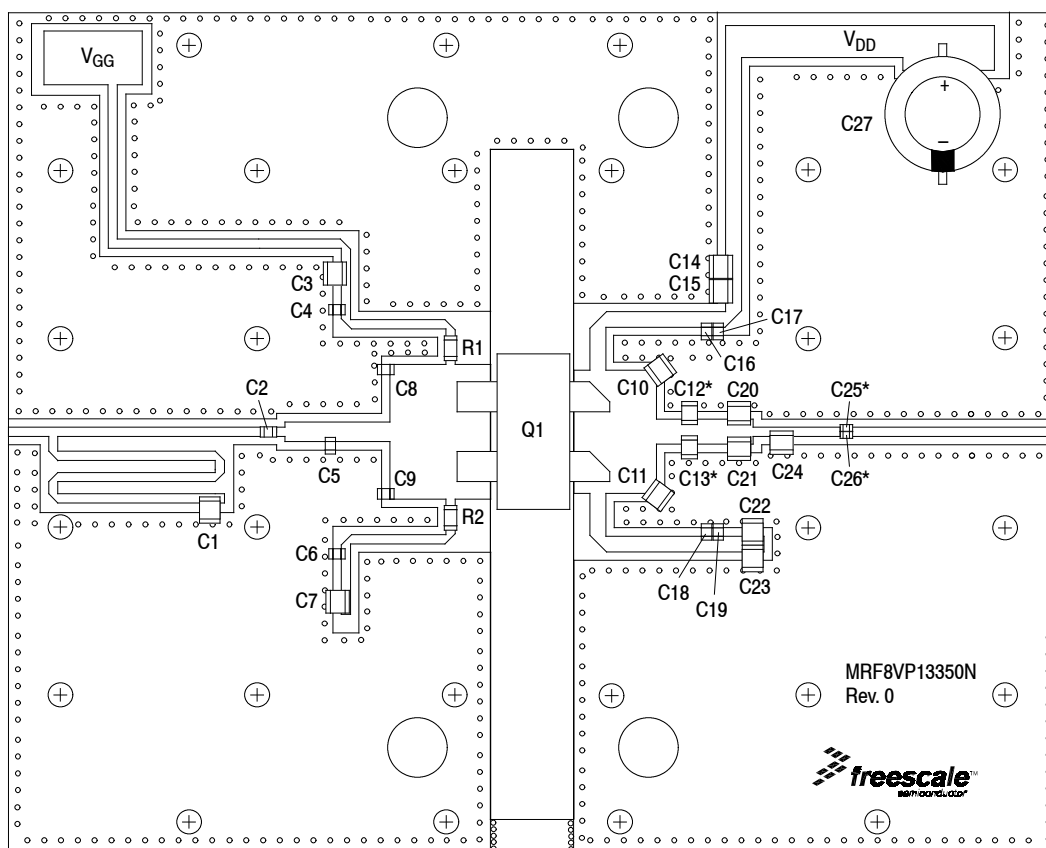

*C12, C13, C25 and C26 are mounted vertically.

Figure 4. MRF8VP13350N Reference Circuit Component Layout — 915 MHz

Table 10. MRF8VP13350N Reference Circuit Component Designations and Values — 915 MHz

Part	Description	Part Number	Manufacturer
C1	62 pF Chip Capacitor	ATC100B620JT500XT	ATC
C2, C5	4.7 pF Chip Capacitors	ATC600F4R7BT250XT	ATC
C3, C7, C14, C15, C22, C23	10 μF Chip Capacitors	GRM32ER61H106KA12L	Murata
C4, C6, C16, C17, C18, C19	47 pF Chip Capacitors	ATC600F470JT250XT	ATC
C8, C9	3.9 pF Chip Capacitors	ATC600F3R9BT250XT	ATC
C10, C11	12 pF Chip Capacitors	ATC800B120JT500XT	ATC
C12, C13	5.6 pF Chip Capacitors	ATC800B5R6CT500XT	ATC
C20, C21	2.4 pF Chip Capacitors	ATC800B2R4BT500XT	ATC
C24	2.7 pF Chip Capacitor	ATC800B2R7BT500XT	ATC
C25, C26	39 pF Chip Capacitors	ATC600S390JT250XT	ATC
C27	470 μF Electrolytic Capacitor	MCGPR63V477M13X26-RH	Multicomp
Q1	RF Power LDMOS Transistor	MRF8VP13350N	NXP
R1, R2	6.2 Ω, 1/4 W Chip Resistors	CRCW12066R20FKEA	Vishay
PCB	Rogers RO4350B, 0.020", ε _r = 3.66	—	MTL

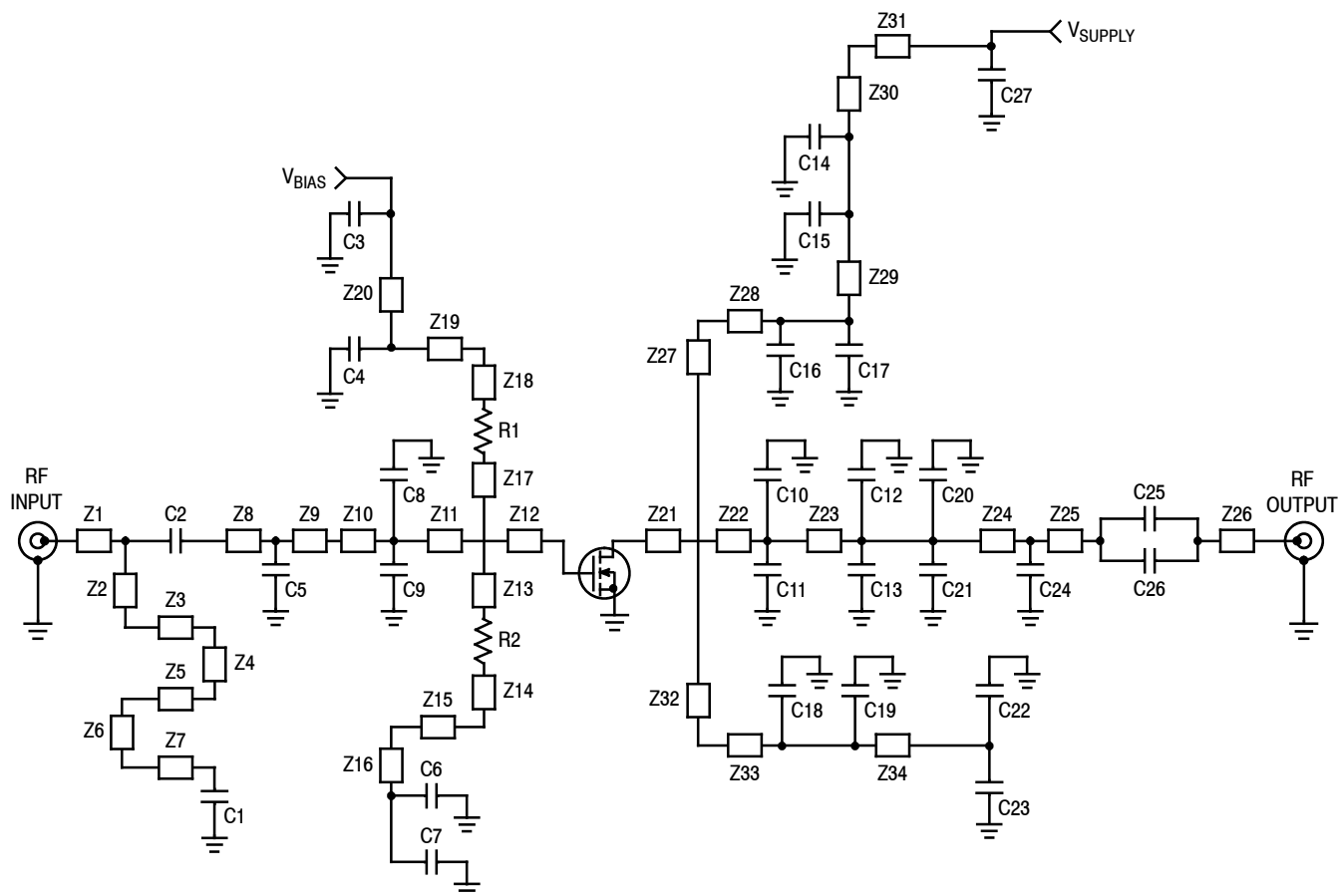

Figure 5. MRF8VP13350N Reference Circuit Schematic — 915 MHz

Table 11. MRF8VP13350N Reference Circuit Microstrips — 915 MHz

Microstrip	Description	Microstrip	Description
Z1	1.218" × 0.044" Microstrip	Z18	0.098" × 0.044" 45° Taper Microstrip
Z2	0.114" × 0.044" 45° Taper Microstrip	Z19	0.489" × 0.044" 45° Taper Microstrip
Z3	0.794" × 0.044" 45° Taper Microstrip	Z20	0.077" × 0.044" 45° Taper Microstrip
Z4	0.101" × 0.044" 45° Taper Microstrip	Z21	0.077" × 0.587" Microstrip
Z5	0.794" × 0.044" 45° Taper Microstrip	Z22	0.241" × 0.587" Microstrip
Z6	0.101" × 0.044" 45° Taper Microstrip	Z23	0.460" × 0.119" Microstrip
Z7	0.794" × 0.044" Microstrip	Z24	0.414" × 0.044" Microstrip
Z8	0.080" × 0.044" Microstrip	Z25	0.223" × 0.044" Microstrip
Z9	0.500" × 0.094" Microstrip	Z26	0.998" × 0.044" Microstrip
Z10	0.010" × 0.642" Microstrip	Z27	0.279" × 0.075" 45° Taper Microstrip
Z11	0.247" × 0.642" Microstrip	Z28	0.643" × 0.075" 45° Taper Microstrip
Z12	0.170" × 0.642" Microstrip	Z29	0.118" × 0.075" Microstrip
Z13	0.044" × 0.050" Microstrip	Z30	1.118" × 0.075" Microstrip
Z14	0.098" × 0.044" 45° Taper Microstrip	Z31	0.769" × 0.153" Microstrip
Z15	0.489" × 0.044" 45° Taper Microstrip	Z32	0.279" × 0.075" 45° Taper Microstrip
Z16	0.331" × 0.044" Microstrip	Z33	0.643" × 0.075" Microstrip
Z17	0.044" × 0.050" Microstrip	Z34	0.094" × 0.075" Microstrip

TYPICAL CHARACTERISTICS — 915 MHz REFERENCE CIRCUIT

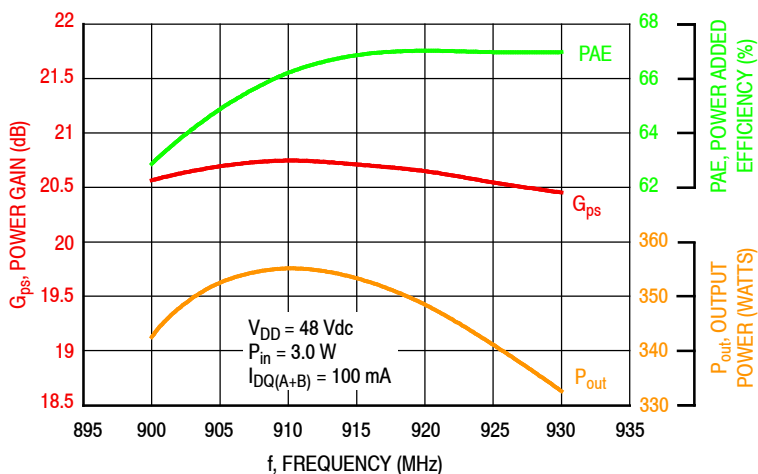

Figure 6. Power Gain, Power Added Efficiency and Output Power versus Frequency at a Constant Input Power

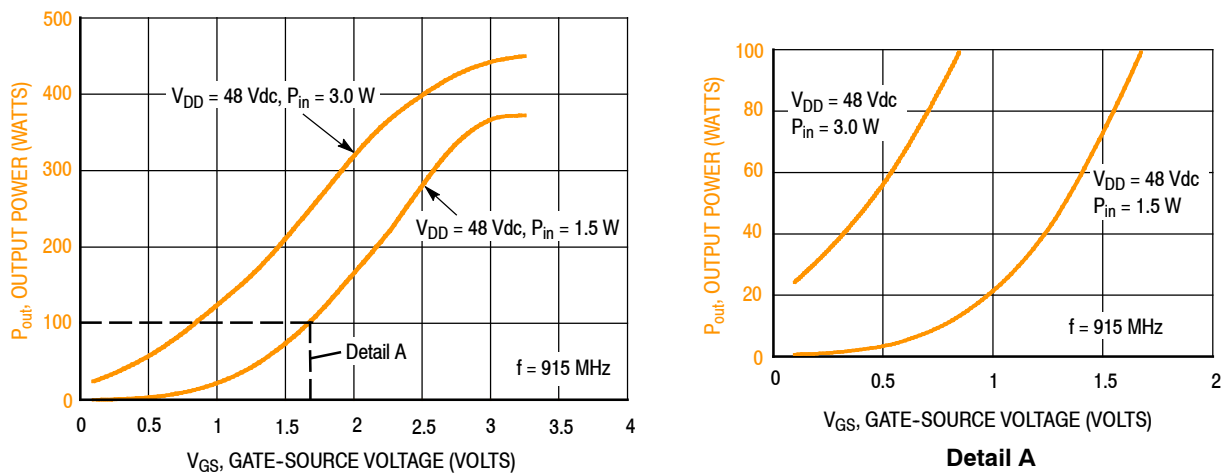

Figure 7. Output Power versus Gate-Source Voltage

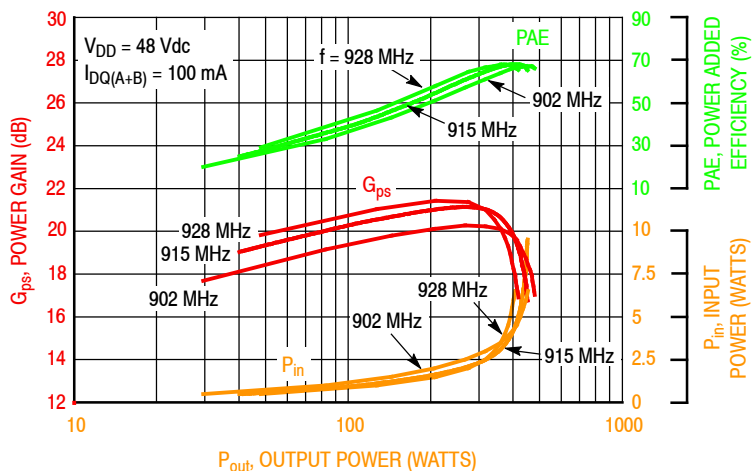

Figure 8. Power Gain, Power Added Efficiency and Input Power versus Output Power and Frequency

TYPICAL CHARACTERISTICS — 915 MHz REFERENCE CIRCUIT

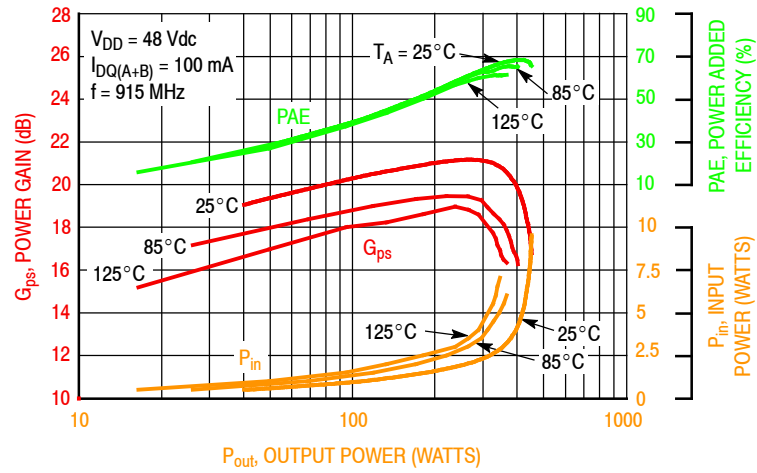

Figure 9. Power Gain, Power Added Efficiency and Input Power versus Output Power and Temperature

1300 MHz NARROWBAND PRODUCTION TEST FIXTURE — 4" x 6" (10.2 cm x 15.2 cm)

Table 12. 1300 MHz Narrowband Performance ^(1,2) (In NXP Test Fixture, 50 ohm system) $V_{DD} = 50$ Vdc, $I_{DQ(A+B)} = 100$ mA, $P_{out} = 350$ W Peak (70 W Avg.), $f = 1300$ MHz, 100 μ sec Pulse Width, 20% Duty Cycle

Characteristic	Symbol	Min	Typ	Max	Unit
Power Gain	G_{ps}	17.5	19.2	20.5	dB
Drain Efficiency	η_D	55.0	58.0	—	%

1. Part internally input matched.
2. Measurement made with device in straight lead configuration before any lead forming operation is applied. Lead forming is used for gull wing (GN) parts.

1300 MHz NARROWBAND PRODUCTION TEST FIXTURE — 4" x 6" (10.2 cm x 15.2 cm)

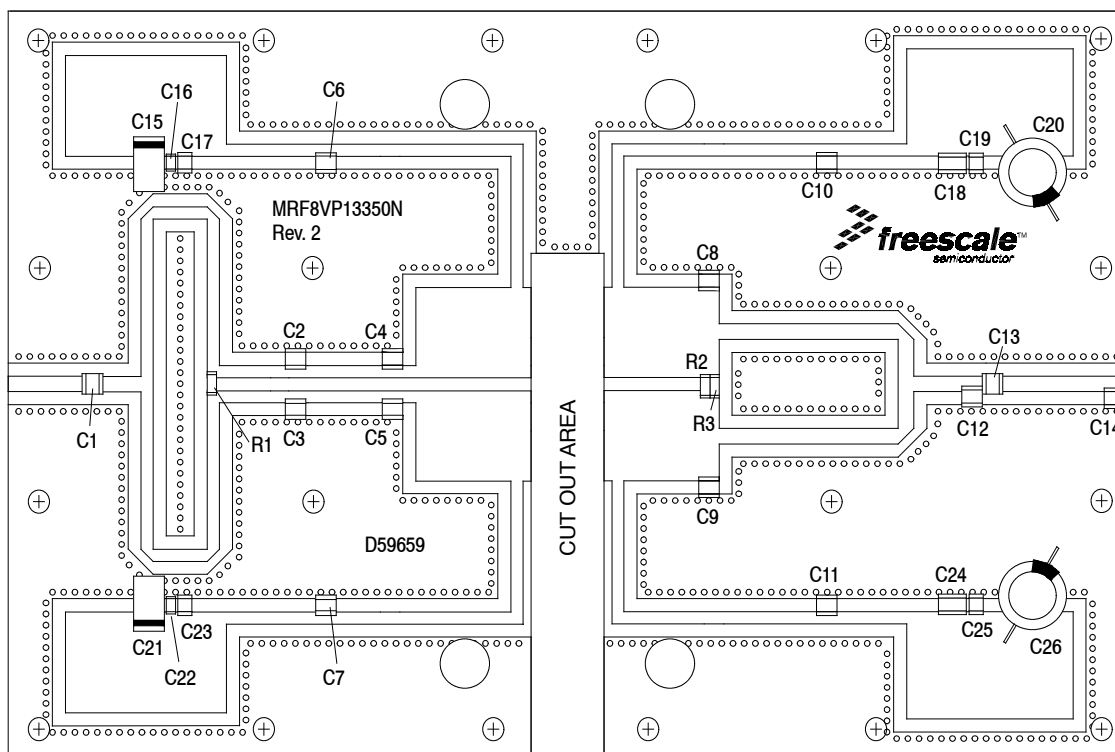

Figure 10. MRF8VP13350N Narrowband Test Circuit Component Layout — 1300 MHz

Table 13. MRF8VP13350N Narrowband Test Circuit Component Designations and Values — 1300 MHz

Part	Description	Part Number	Manufacturer
C1, C13	10 pF Chip Capacitors	ATC800B100JT500XT	ATC
C2, C3	6.2 pF Chip Capacitors	ATC800B6R2BT500XT	ATC
C4, C5	8.2 pF Chip Capacitors	ATC800B8R2CT500XT	ATC
C6, C7, C10, C11	180 pF Chip Capacitors	ATC800B181JT300XT	ATC
C8, C9	4.7 pF Chip Capacitors	ATC800B4R7CT500XT	ATC
C12	1.0 pF Chip Capacitor	ATC800B1R0BT500XT	ATC
C14	1.7 pF Chip Capacitor	ATC800B1R7BT500XT	ATC
C15, C21	47 μ F Tantalum Capacitors	593D476X9016D2TE3	Vishay/Sprague
C16, C22	0.1 μ F Chip Capacitors	C1206C104K1RACTU	Kemet
C17, C23	0.22 μ F Chip Capacitors	C1210C224K1RACTU	Kemet
C18, C24	0.1 μ F Chip Capacitors	C1206C104K1RACTU	Kemet
C19, C25	2.2 μ F Chip Capacitors	2225X7R225KT3AB	ATC
C20, C26	330 μ F, 63 V Electrolytic Capacitors	MCRH63V337M13X21-RH	Multicomp
R1	100 Ω , 1/4 W Chip Resistor	CRCW1206100RFKEA	Vishay
R2, R3	200 Ω , 1/4 W Chip Resistors	CRCW1206200RFKEA	Vishay
PCB	Arlon AD255A, 0.030", $\epsilon_r = 2.55$	D59659	MTL

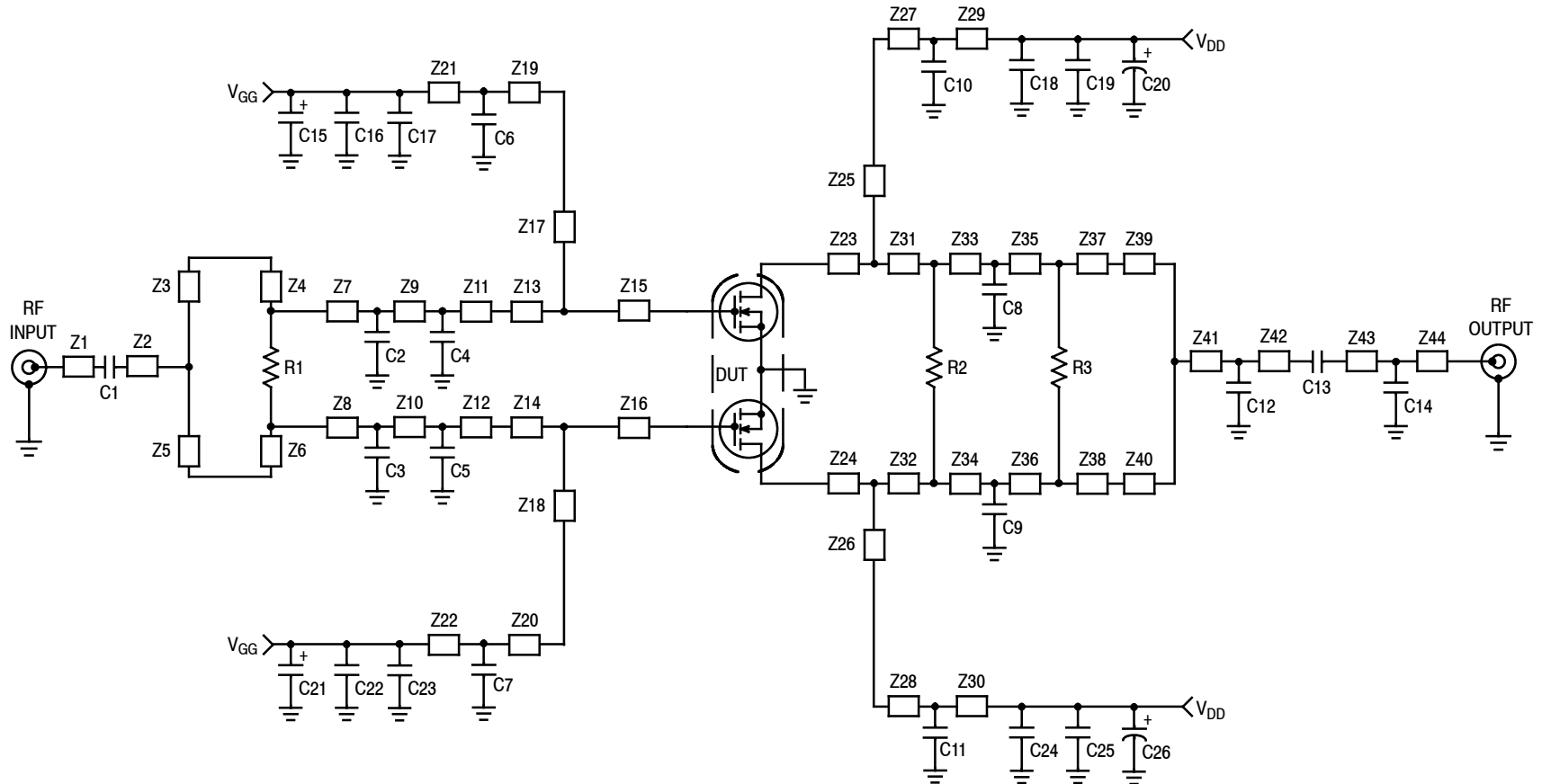

Figure 11. MRF8VP13350N Narrowband Test Circuit Schematic — 1300 MHz

Table 14. MRF8VP13350N Narrowband Test Circuit Microstrips — 1300 MHz

Microstrip	Description	Microstrip	Description	Microstrip	Description
Z1	0.410" × 0.083" Microstrip	Z17, Z18	0.768" × 0.065" Microstrip	Z33, Z34	0.020" × 0.485" Microstrip
Z2	0.233" × 0.083" Microstrip	Z19, Z20	0.993" × 0.065" Microstrip	Z35, Z36	0.030" × 0.485" Microstrip
Z3, Z5	1.096" × 0.065" Microstrip*	Z21, Z22	0.534" × 0.065" Microstrip	Z37, Z38	0.025" × 0.485" Microstrip
Z4, Z6	1.061" × 0.065" Microstrip*	Z23, Z24	0.075" × 0.485" Microstrip	Z39, Z40	1.283" × 0.084" Microstrip*
Z7, Z8	0.409" × 0.065" Microstrip	Z25, Z26	0.768" × 0.065" Microstrip	Z41	0.313" × 0.083" Microstrip
Z9, Z10	0.519" × 0.065" Microstrip	Z27, Z28	1.088" × 0.065" Microstrip	Z42	0.075" × 0.083" Microstrip
Z11, Z12	0.125" × 0.065" Microstrip	Z29, Z30	0.429" × 0.065" Microstrip	Z43	0.619" × 0.083" Microstrip
Z13, Z14	0.543" × 0.485" Microstrip	Z31, Z32	0.468" × 0.485" Microstrip	Z44	0.065" × 0.083" Microstrip
Z15, Z16	0.075" × 0.485" Microstrip				

* Line length include microstrip bends

TYPICAL CHARACTERISTICS — 1300 MHz

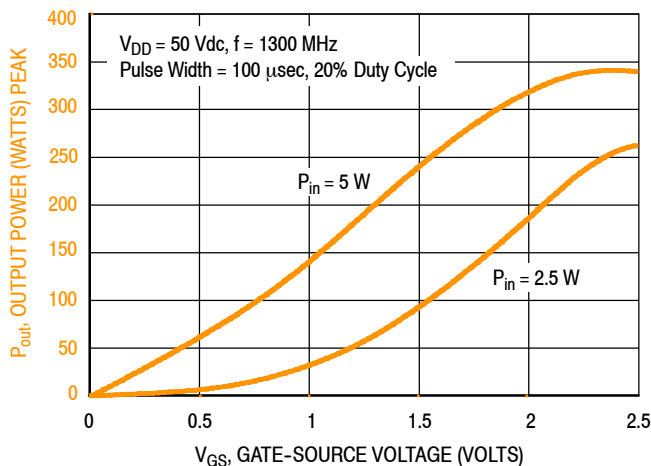
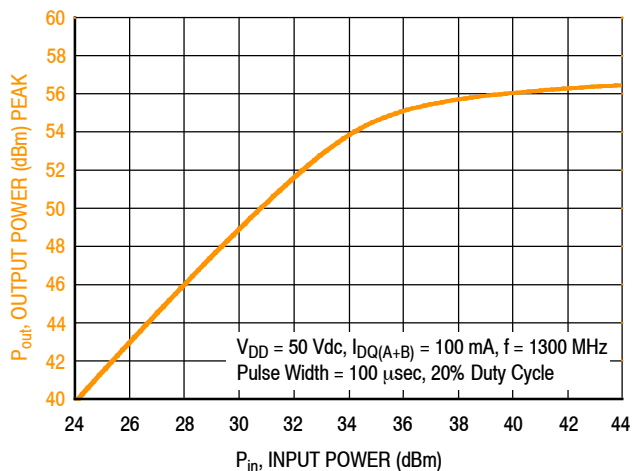

Figure 12. Output Power versus Gate-Source Voltage at a Constant Input Power



f (MHz)	P1dB (W)	P3dB (W)
1300	338	390

Figure 13. Output Power versus Input Power

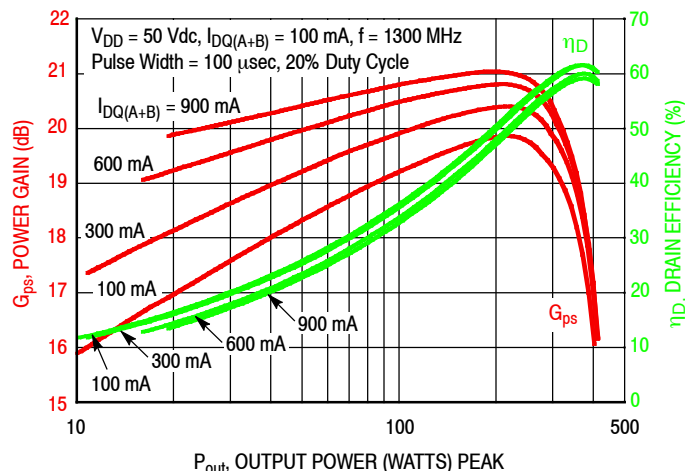

Figure 14. Power Gain and Drain Efficiency versus Output Power and Quiescent Current

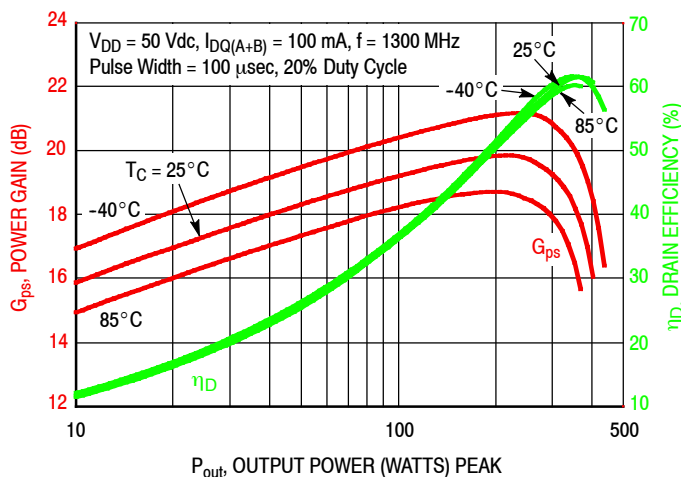

Figure 15. Power Gain and Drain Efficiency versus Output Power

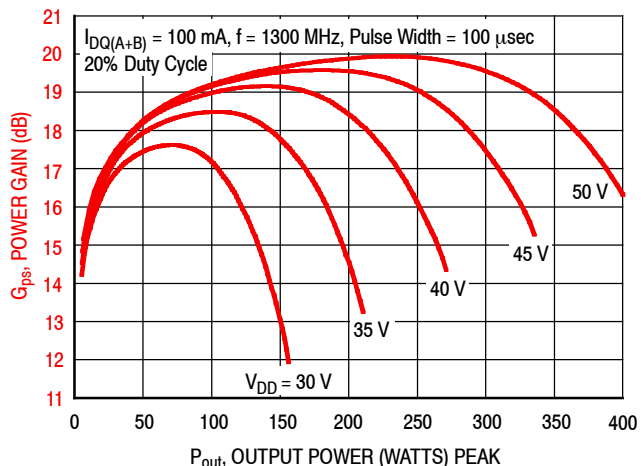

Figure 16. Power Gain versus Output Power and Drain-Source Voltage

1300 MHz NARROWBAND PRODUCTION TEST FIXTURE

f MHz	Z_{source} Ω	Z_{load} Ω
1300	5.1 + j3.6	2.1 + j3.9

Z_{source} = Test circuit impedance as measured from gate to gate, balanced configuration.

Z_{load} = Test circuit impedance as measured from drain to drain, balanced configuration.

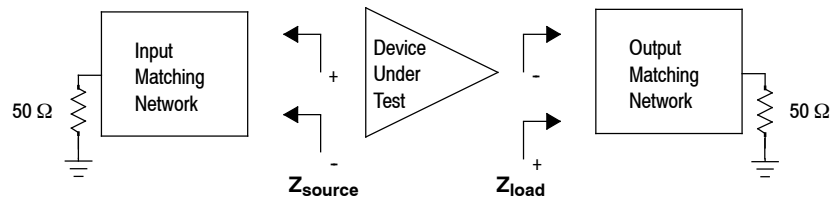
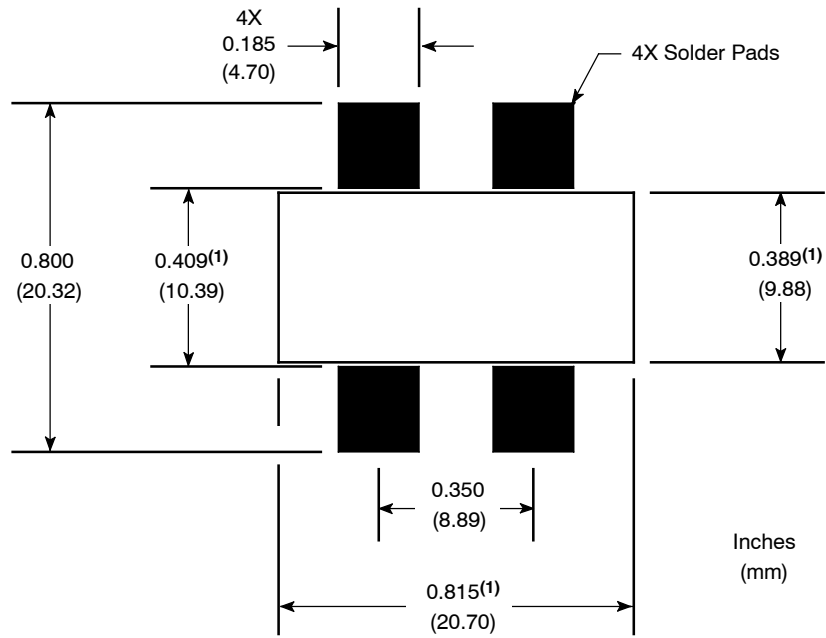

Figure 17. Narrowband Series Equivalent Source and Load Impedance — 1300 MHz



1. Slot dimensions are minimum dimensions and exclude milling tolerances.

Figure 18. PCB Pad Layout for OM-780-4L

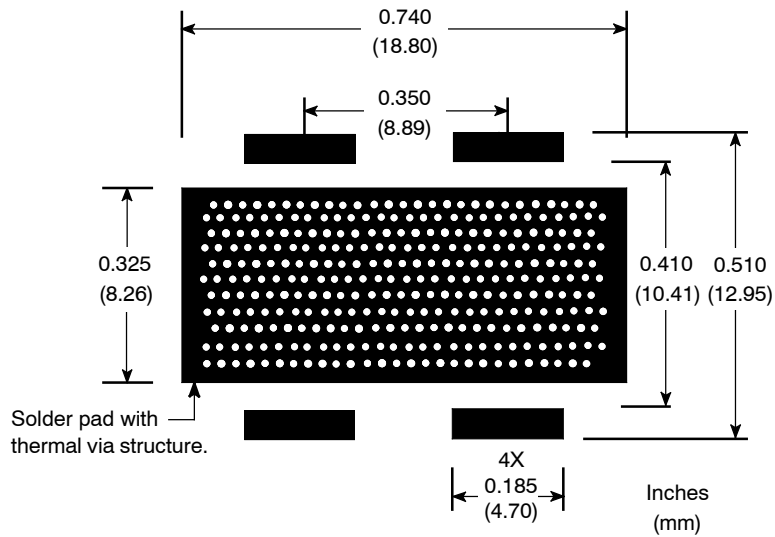
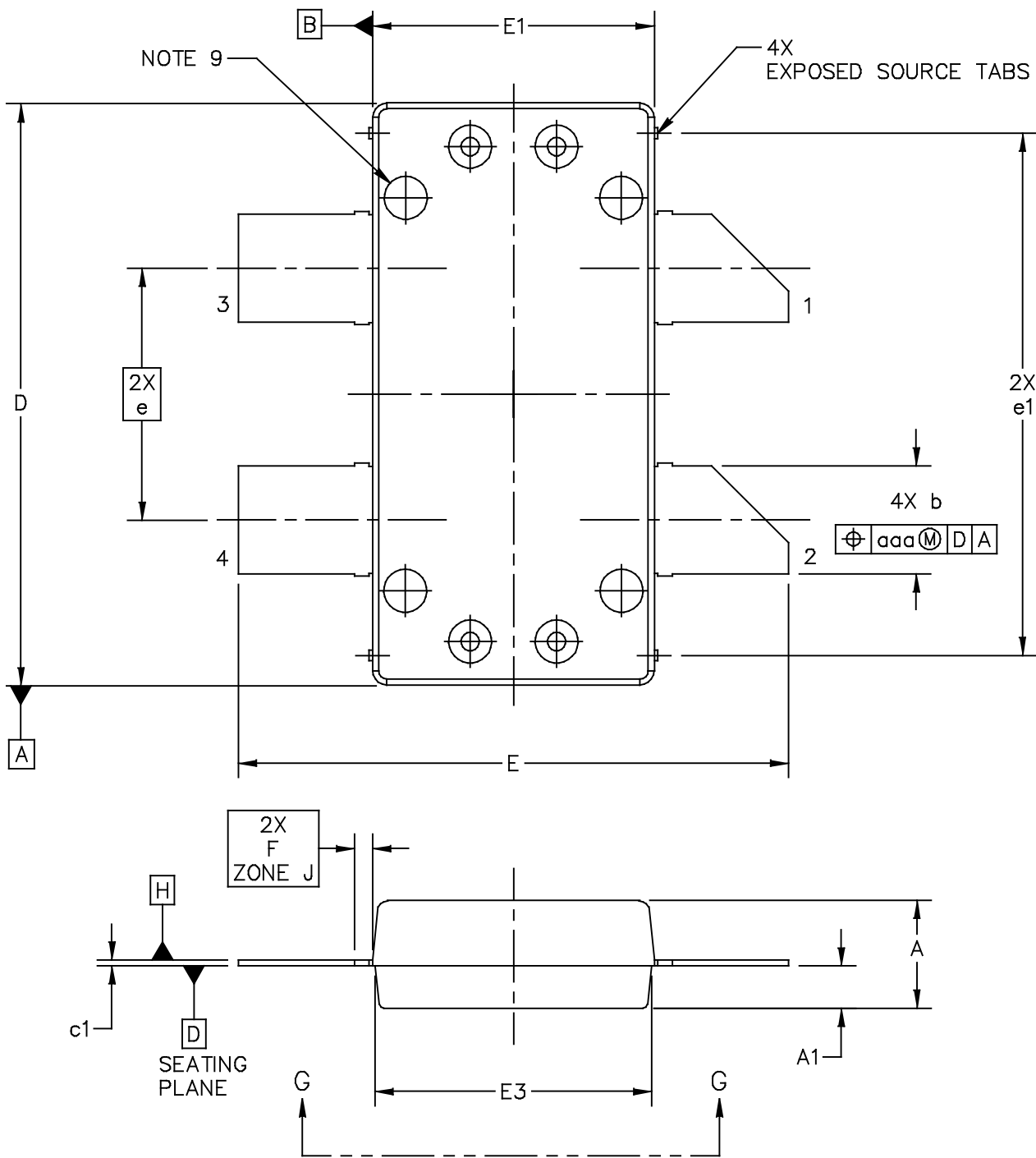
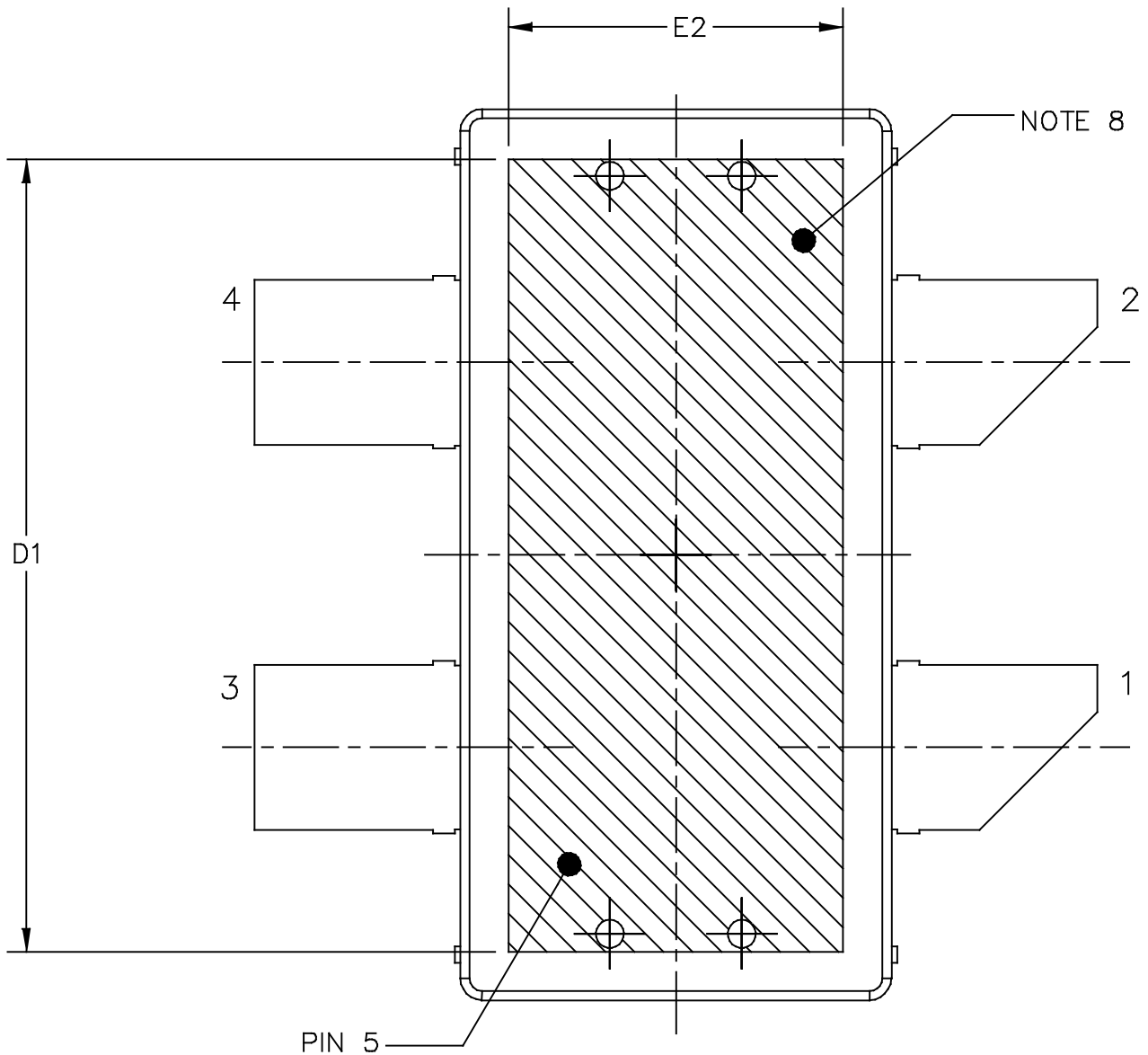

Figure 19. PCB Pad Layout for OM-780G-4L

PACKAGE DIMENSIONS



© NXP SEMICONDUCTORS N.V. ALL RIGHTS RESERVED	MECHANICAL OUTLINE	PRINT VERSION NOT TO SCALE
TITLE: OM780-4 STRAIGHT LEAD	DOCUMENT NO: 98ASA10833D	REV: B
	STANDARD: NON-JEDEC	
	SOT1818-4	16 MAR 2016



BOTTOM VIEW
VIEW G-G

© NXP SEMICONDUCTORS N.V. ALL RIGHTS RESERVED	MECHANICAL OUTLINE	PRINT VERSION NOT TO SCALE
TITLE: OM780-4 STRAIGHT LEAD	DOCUMENT NO: 98ASA10833D	REV: B
	STANDARD: NON-JEDEC	
	SOT1818-4	16 MAR 2016

MRF8VP13350N MRF8VP13350GN

NOTES:

1. CONTROLLING DIMENSION: INCH
2. INTERPRET DIMENSIONS AND TOLERANCES PER ASME Y14.5M-1994.
3. DATUM PLANE -H- IS LOCATED AT TOP OF LEAD AND IS COINCIDENT WITH THE LEAD WHERE THE LEAD EXITS THE PLASTIC BODY AT THE TOP OF THE PARTING LINE.
4. DIMENSIONS "D" AND "E1" DO NOT INCLUDE MOLD PROTRUSION. ALLOWABLE PROTRUSION IS .006 PER SIDE. DIMENSIONS "D AND "E1" DO INCLUDE MOLD MISMATCH AND ARE DETERMINED AT DATUM PLANE -H-.
5. DIMENSION b DOES NOT INCLUDE DAMBAR PROTRUSION. ALLOWABLE DAMBAR PROTRUSION SHALL BE .005 TOTAL IN EXCESS OF THE b DIMENSION AT MAXIMUM MATERIAL CONDITION.
6. DATUMS -A- AND -B- TO BE DETERMINED AT DATUM PLANE -H-.
7. DIMENSION A1 APPLIES WITHIN ZONE "J" ONLY.
8. HATCHING REPRESENTS THE EXPOSED AREA OF THE HEAT SLUG. THE DIMENSIONS D1 AND E2 REPRESENT THE VALUES BETWEEN THE TWO OPPOSITE POINTS ALONG THE EDGES OF EXPOSED AREA OF HEAT SLUG.
9. DIMPLED HOLE REPRESENTS INPUT SIDE.

DIM	INCH		MILLIMETER		DIM	INCH		MILLIMETER	
	MIN	MAX	MIN	MAX		MIN	MAX	MIN	MAX
A	0.148	.152	3.76	3.86	b	.147	.153	3.73	3.89
A1	.059	.065	1.50	1.65	c1	.007	.011	0.18	0.28
D	.808	.812	20.52	20.62	e	.350 BSC		8.89 BSC	
D1	.720	----	18.29	----	e1	.721	.729	18.31	18.52
E	.762	.770	19.36	19.56					
E1	.390	.394	9.91	10.01	aaa	.004		0.10	
E2	.306	----	7.77	----					
E3	.383	.387	9.72	9.83					
F	.025 BSC		0.635 BSC						
© NXP SEMICONDUCTORS N.V. ALL RIGHTS RESERVED			MECHANICAL OUTLINE			PRINT VERSION NOT TO SCALE			
TITLE: OM780-4 STRAIGHT LEAD					DOCUMENT NO: 98ASA10833D				REV: B
					STANDARD: NON-JEDEC				
					SOT1818-4			16 MAR 2016	

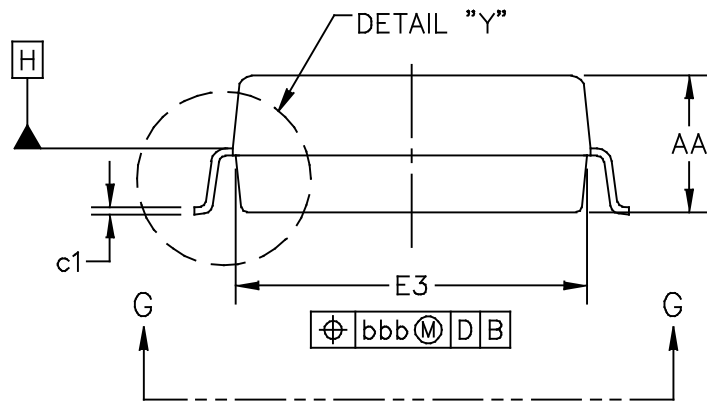
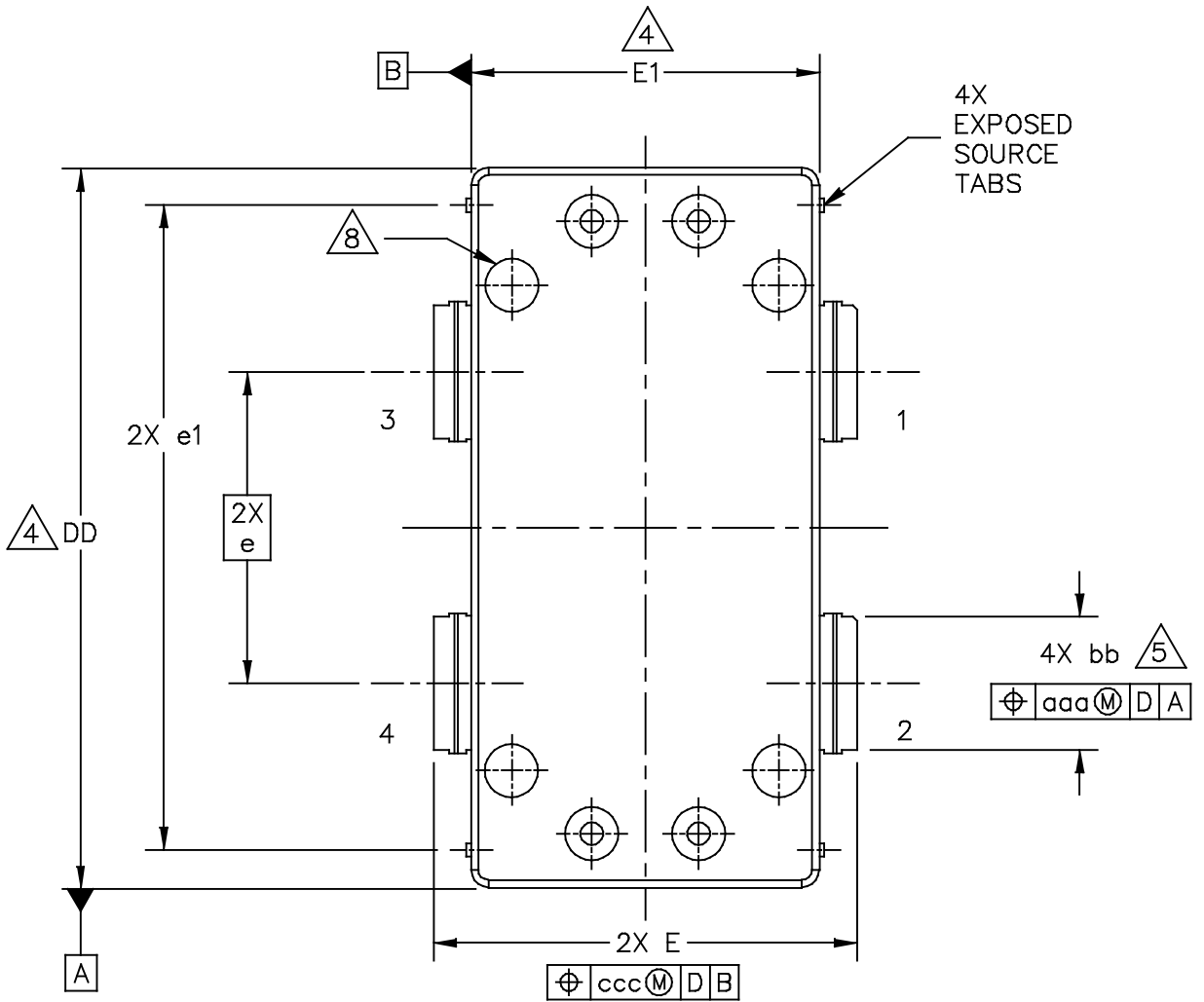

© NXP SEMICONDUCTORS N.V. ALL RIGHTS RESERVED	MECHANICAL OUTLINE	PRINT VERSION NOT TO SCALE
TITLE: OM-780G-4L	DOCUMENT NO: 98ASA10834D STANDARD: NON-JEDEC SOT1825-1	REV: E 16 MAR 2016

MRF8VP13350N MRF8VP13350GN

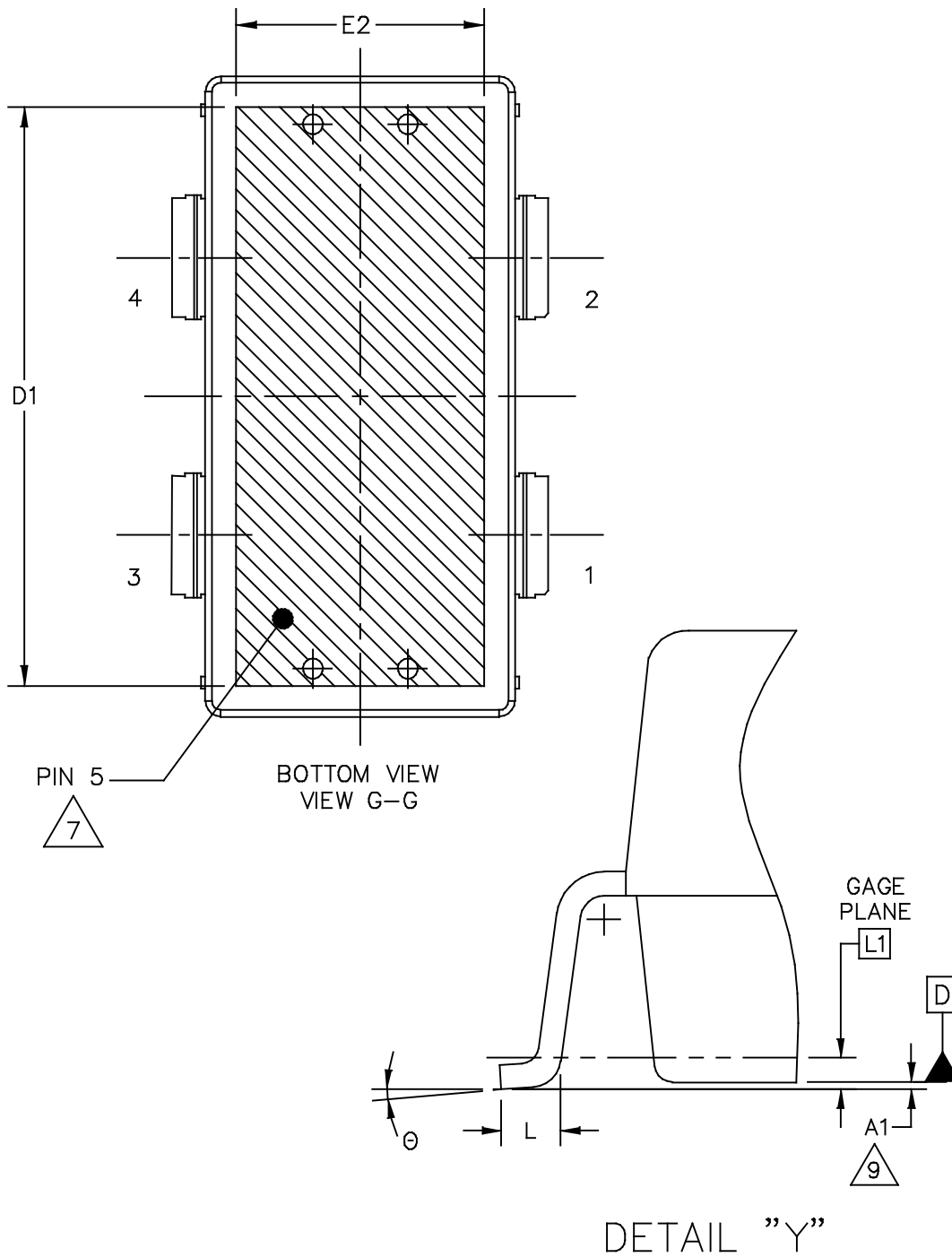

© NXP SEMICONDUCTORS N.V. ALL RIGHTS RESERVED	MECHANICAL OUTLINE	PRINT VERSION NOT TO SCALE
TITLE: OM-780G-4L	DOCUMENT NO: 98ASA10834D	REV: E
	STANDARD: NON-JEDEC	
	SOT1825-1	16 MAR 2016

NOTES:

1. CONTROLLING DIMENSION: INCH
2. INTERPRET DIMENSIONS AND TOLERANCES PER ASME Y14.5M-1994.
3. DATUM PLANE H IS LOCATED AT TOP OF LEAD AND IS COINCIDENT WITH THE LEAD WHERE THE LEAD EXITS THE PLASTIC BODY AT THE TOP OF THE PARTING LINE.
4. DIMENSIONS DD AND E1 DO NOT INCLUDE MOLD PROTRUSION. ALLOWABLE PROTRUSION IS .006 INCH (0.15 MM) PER SIDE. DIMENSIONS DD AND E1 DO INCLUDE MOLD MISMATCH AND ARE DETERMINED AT DATUM PLANE H.
5. DIMENSION bb DOES NOT INCLUDE DAMBAR PROTRUSION. ALLOWABLE DAMBAR PROTRUSION SHALL BE .005 INCH (0.13 MM) TOTAL IN EXCESS OF THE bb DIMENSION AT MAXIMUM MATERIAL CONDITION.
6. DATUMS A AND B TO BE DETERMINED AT DATUM PLANE H.
7. HATCHING REPRESENTS THE EXPOSED AREA OF THE HEAT SLUG. THE DIMENSIONS D1 AND E2 REPRESENT THE VALUES BETWEEN THE TWO OPPOSITE POINTS ALONG THE EDGES OF EXPOSED AREA OF HEAT SLUG.
8. DIMPLED HOLE REPRESENTS INPUT SIDE.
9. DIMENSION A1 IS MEASURED WITH REFERENCE TO DATUM D. THE POSITIVE VALUE IMPLIES THAT THE BOTTOM OF PACKAGE IS HIGHER THAN THE BOTTOM OF THE LEAD.

DIM	INCH		MILLIMETER		DIM	INCH		MILLIMETER	
	MIN	MAX	MIN	MAX		MIN	MAX	MIN	MAX
AA	.148	.152	3.76	3.86	bb	.147	.153	3.73	3.89
A1	-.002	.002	-0.05	0.05	c1	.007	.011	0.18	0.28
DD	.808	.812	20.52	20.62	e	0.350 BSC		8.89 BSC	
D1	.720	----	18.29	----	e1	.721	.729	18.31	18.52
E	.470	.482	11.94	12.24	θ	0°	8°	0°	8°
E1	.390	.394	9.91	10.01	aaa	.004		0.10	
E2	.306	----	7.77	----	bbb	.006		0.15	
E3	.383	.387	9.73	9.83	ccc	.010		0.25	
L	.018	.024	0.46	0.61					
L1	.010 BSC		0.25 BSC						

© NXP SEMICONDUCTORS N.V. ALL RIGHTS RESERVED		MECHANICAL OUTLINE	PRINT VERSION NOT TO SCALE
TITLE: OM-780G-4L		DOCUMENT NO: 98ASA10834D REV: E	
		STANDARD: NON-JEDEC	
		SOT1825-1	16 MAR 2016

PRODUCT DOCUMENTATION, SOFTWARE AND TOOLS

Refer to the following resources to aid your design process.

Application Notes

- AN1907: Solder Reflow Attach Method for High Power RF Devices in Over-Molded Plastic Packages
- AN1955: Thermal Measurement Methodology of RF Power Amplifiers

Engineering Bulletins

- EB212: Using Data Sheet Impedances for RF LDMOS Devices

Software

- Electromigration MTTF Calculator
- RF High Power Model
- .s2p File

Development Tools

- Printed Circuit Boards

To Download Resources Specific to a Given Part Number:

1. Go to <http://www.nxp.com/RF>
2. Search by part number
3. Click part number link
4. Choose the desired resource from the drop down menu

REVISION HISTORY

The following table summarizes revisions to this document.

Revision	Date	Description
0	May 2015	<ul style="list-style-type: none">• Initial Release of Data Sheet
1	Oct. 2015	<ul style="list-style-type: none">• Table 2, Thermal Characteristics: added thermal resistance data for the 915 MHz reference circuit, p. 2
2	Feb. 2017	<ul style="list-style-type: none">• Table 10, MRF8VP13350N Reference Circuit Component Designations and Values — 915 MHz: updated Q1 to correct part number, p. 6• Fig. 11, Narrowband Test Circuit Schematic — 1300 MHz: corrected C6, C7, C10 and C11 bias line chip capacitor connection, p. 12

How to Reach Us:

Home Page:
nxp.com

Web Support:
nxp.com/support

Information in this document is provided solely to enable system and software implementers to use NXP products. There are no express or implied copyright licenses granted hereunder to design or fabricate any integrated circuits based on the information in this document. NXP reserves the right to make changes without further notice to any products herein.

NXP makes no warranty, representation, or guarantee regarding the suitability of its products for any particular purpose, nor does NXP assume any liability arising out of the application or use of any product or circuit, and specifically disclaims any and all liability, including without limitation consequential or incidental damages. "Typical" parameters that may be provided in NXP data sheets and/or specifications can and do vary in different applications, and actual performance may vary over time. All operating parameters, including "typicals," must be validated for each customer application by customer's technical experts. NXP does not convey any license under its patent rights nor the rights of others. NXP sells products pursuant to standard terms and conditions of sale, which can be found at the following address: nxp.com/SalesTermsandConditions.

NXP, the NXP logo, Freescale, and the Freescale logo are trademarks of NXP B.V. All other product or service names are the property of their respective owners.
© 2015–2017 NXP B.V.



Компания «Океан Электроники» предлагает заключение долгосрочных отношений при поставках импортных электронных компонентов на взаимовыгодных условиях!

Наши преимущества:

- Поставка оригинальных импортных электронных компонентов напрямую с производств Америки, Европы и Азии, а так же с крупнейших складов мира;
- Широкая линейка поставок активных и пассивных импортных электронных компонентов (более 30 млн. наименований);
- Поставка сложных, дефицитных, либо снятых с производства позиций;
- Оперативные сроки поставки под заказ (от 5 рабочих дней);
- Экспресс доставка в любую точку России;
- Помощь Конструкторского Отдела и консультации квалифицированных инженеров;
- Техническая поддержка проекта, помощь в подборе аналогов, поставка прототипов;
- Поставка электронных компонентов под контролем ВП;
- Система менеджмента качества сертифицирована по Международному стандарту ISO 9001;
- При необходимости вся продукция военного и аэрокосмического назначения проходит испытания и сертификацию в лаборатории (по согласованию с заказчиком);
- Поставка специализированных компонентов военного и аэрокосмического уровня качества (Xilinx, Altera, Analog Devices, Intersil, Interpoint, Microsemi, Actel, Aeroflex, Peregrine, VPT, Syfer, Eurofarad, Texas Instruments, MS Kennedy, Miteq, Cobham, E2V, MA-COM, Hittite, Mini-Circuits, General Dynamics и др.);

Компания «Океан Электроники» является официальным дистрибьютором и эксклюзивным представителем в России одного из крупнейших производителей разъемов военного и аэрокосмического назначения «JONHON», а так же официальным дистрибьютором и эксклюзивным представителем в России производителя высокотехнологичных и надежных решений для передачи СВЧ сигналов «FORSTAR».



JONHON

«JONHON» (основан в 1970 г.)

Разъемы специального, военного и аэрокосмического назначения:

(Применяются в военной, авиационной, аэрокосмической, морской, железнодорожной, горно- и нефтедобывающей отраслях промышленности)

«FORSTAR» (основан в 1998 г.)

ВЧ соединители, коаксиальные кабели, кабельные сборки и микроволновые компоненты:

(Применяются в телекоммуникациях гражданского и специального назначения, в средствах связи, РЛС, а так же военной, авиационной и аэрокосмической отраслях промышленности).



Телефон: 8 (812) 309-75-97 (многоканальный)

Факс: 8 (812) 320-03-32

Электронная почта: ocean@oceanchips.ru

Web: <http://oceanchips.ru/>

Адрес: 198099, г. Санкт-Петербург, ул. Калинина, д. 2, корп. 4, лит. А