

Little Star® 1 Watt Power SMD LED

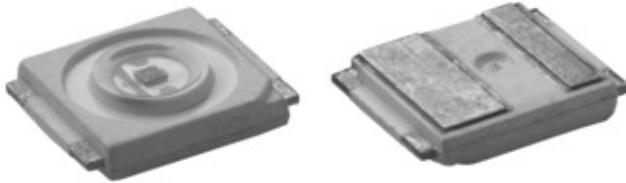

20783

FEATURES

- Super high brightness surface mount LED
- High flux output
- 120° viewing angle
- Compact package outline (L x W x H) of 6.0 x 6.0 x 1.5 mm
- Ultra low height profile - 1.5 mm
- Designed for high current drive; typically 400 mA
- Low thermal resistance; $R_{thJP} = 20$ K/W
- Qualified according to JEDEC moisture sensitivity level 2a
- Compatible with IR reflow solder processes according to CECC 00802 and J-STD-020C
- Little Star® are class 1M LED products. Do not view directly with optical instrument
- Component in accordance to RoHS 2002/95/EC and WEEE 2002/96/EC
- Automotive qualified AEC-Q101
- ESD-withstand voltage: up to 2 kV according to JESD22-A114-B
- Optical efficiency typical up to 52 lm/W

DESCRIPTION

The VLMK/R/Y71.. is one of the most robust and light efficient LEDs in the market. With its extremely high level of brightness and the ultra low high profile, which is only 1.5 mm are highly suitable for both conventional lighting and specialized application such as automotive signal lights, traffic lights, channel lights, tube lights and garden lights among others.

PRODUCT GROUP AND PACKAGE DATA

- Product group: LED
- Package: SMD Little Star
- Product series: power
- Angle of half intensity: $\pm 60^\circ$

APPLICATIONS

- Automotive: exterior applications, e.g.: center high mounted stop light (CHMSL), rear combination lights (RCLs), signal lighting, etc.
- Communication: indicator and backlight in mobile phone
- Industry: white goods (e.g.: oven, microwave, etc.)
- Lighting: garden light, architecture lighting, general lighting, etc.

PARTS TABLE			
PART	COLOR, LUMINOUS INTENSITY (at $I_F = 400$ mA)	LUMINOUS FLUX CORRELATION BETWEEN LUM. FLUX/LUM. INTENSITY (at $I_F = 400$ mA)	TECHNOLOGY
VLMK71ABAD-GS08	Amber, $I_V = (9000 \text{ to } 18000)$ mcd	26100 to 52000 mlm	AllnGaP
VLMR71AAAC-GS08	Red, $I_V = (7150 \text{ to } 14000)$ mcd	20700 to 39000 mlm	AllnGaP
VLMY71AAAC-GS08	Yellow, $I_V = (7150 \text{ to } 14000)$ mcd	20700 to 39000 mlm	AllnGaP

ABSOLUTE MAXIMUM RATINGS ¹⁾ VLMK71../VLMR71../VLMY71..				
PARAMETER	TEST CONDITION	SYMBOL	VALUE	UNIT
Forward current		I_F	400	mA
Power dissipation		P_{tot}	1120	mW
Junction temperature		T_j	+ 120	°C
Surge current $t < 10 \mu s, d = 0.1$		I_{FM}	500	mA
Operating temperature range		T_{amb}	- 40 to + 100	°C
Storage temperature range		T_{stg}	- 40 to + 100	°C
Thermal resistance junction/pin		R_{thJP}	20	K/W

Note:

Not designed for reverse operation

¹⁾ $T_{amb} = 25 \text{ °C}$, unless otherwise specified

OPTICAL AND ELECTRICAL CHARACTERISTICS ¹⁾ VLMK71..., AMBER								
PARAMETER	TEST CONDITION	PART	INCLUDED TYPES	SYMBOL	MIN.	TYP.	MAX.	UNIT
Luminous intensity	$I_F = 400 \text{ mA}$	VLMK71ABAD	VLMK71AB	I_V	9000		11250	mcd
			VLMK71AC	I_V	11250		14000	mcd
			VLMK71AD	I_V	14000		18000	mcd
Dominant wavelength	$I_F = 400 \text{ mA}$			λ_d	610		620	nm
Spectral bandwidth at 50 % $I_{rel \text{ max}}$	$I_F = 400 \text{ mA}$			$\Delta\lambda$		18		nm
Angle of half intensity	$I_F = 400 \text{ mA}$			φ		60		deg
Forward voltage ²⁾	$I_F = 400 \text{ mA}$			V_F	2.2		2.8	V
Optical efficiency	$I_F = 400 \text{ mA}$			η_{opt}		40	52	lm/W

Note:

¹⁾ $T_{amb} = 25 \text{ °C}$, unless otherwise specified

²⁾ Forward voltages are tested at a current pulse duration of 1 ms and a tolerance of $\pm 0.05 \text{ V}$

OPTICAL AND ELECTRICAL CHARACTERISTICS ¹⁾ VLMR71..., RED								
PARAMETER	TEST CONDITION	PART	INCLUDED TYPES	SYMBOL	MIN.	TYP.	MAX.	UNIT
Luminous intensity	$I_F = 400 \text{ mA}$	VLMR71AAAC	VLMR71AA	I_V	7150		9000	mcd
			VLMR71AB	I_V	9000		11250	mcd
			VLMR71AC	I_V	11250		14000	mcd
Dominant wavelength	$I_F = 400 \text{ mA}$			λ_d	620		630	nm
Spectral bandwidth at 50 % $I_{rel \text{ max}}$	$I_F = 400 \text{ mA}$			$\Delta\lambda$		18		nm
Angle of half intensity	$I_F = 400 \text{ mA}$			φ		60		deg
Forward voltage ²⁾	$I_F = 400 \text{ mA}$			V_F	2.2		2.8	V
Optical efficiency	$I_F = 400 \text{ mA}$			η_{opt}		30	39	lm/W

Note:

¹⁾ $T_{amb} = 25 \text{ °C}$, unless otherwise specified

²⁾ Forward voltages are tested at a current pulse duration of 1 ms and a tolerance of $\pm 0.05 \text{ V}$



OPTICAL AND ELECTRICAL CHARACTERISTICS ¹⁾ VLMY71.., YELLOW								
PARAMETER	TEST CONDITION	PART	INCLUDED TYPES	SYMBOL	MIN.	TYP.	MAX.	UNIT
Luminous intensity	$I_F = 400 \text{ mA}$	VLMY71AAAC	VLMY71AA	I_V	7150		9000	mcd
			VLMY71AB	I_V	9000		11250	mcd
			VLMY71AC	I_V	11250		14000	mcd
Dominant wavelength	$I_F = 400 \text{ mA}$			λ_d	585		597	nm
Spectral bandwidth at 50 % $I_{rel \text{ max}}$	$I_F = 400 \text{ mA}$			$\Delta\lambda$		15		nm
Angle of half intensity	$I_F = 400 \text{ mA}$			ϕ		± 60		deg
Forward voltage ²⁾	$I_F = 400 \text{ mA}$			V_F	2.2		2.8	V
Optical efficiency	$I_F = 400 \text{ mA}$			η_{opt}		30	39	lm/W

Note:

¹⁾ $T_{amb} = 25 \text{ }^\circ\text{C}$, unless otherwise specified

²⁾ Forward voltages are tested at a current pulse duration of 1 ms and a tolerance of $\pm 0.05 \text{ V}$

LUMINOUS INTENSITY/FLUX CLASSIFICATION RED/AMBER/YELLOW				
GROUP	LUMINOUS INTENSITY I_V (MCD)		LUMINOUS FLUX Φ_V (MLM)	
	MIN.	MAX.	CORRELATION TABLE	
STANDARD	MIN.	MAX.	MIN.	MAX.
AA	7150	9000	20700	26100
AB	9000	11250	26100	33000
AC	11250	14000	33000	39000
AD	14000	18000	39000	52000
AE	18000	22400	52000	71000
AF	22400	28500	71000	97000

Note:

Luminous intensity is tested at a current pulse duration of 25 ms and an accuracy of $\pm 11 \%$.

The above type numbers represent the order groups which include only a few brightness groups. Only one group will be shipped on each reel (there will be no mixing of two groups on each reel).

In order to ensure availability, single brightness groups will not be orderable.

In a similar manner for colors where wavelength groups are measured and binned, single wavelength groups will be shipped in any one reel.

In order to ensure availability, single wavelength groups will not be orderable.

COLOR CLASSIFICATION				
GROUP	DOM. WAVELENGTH (NM)		DOM. WAVELENGTH (NM)	
	YELLOW		AMBER	
	MIN.	MAX.	MIN.	MAX.
A	585	588	610	616
B	588	591	616	620
C	591	594		
D	594	597		

Note:

Wavelengths are tested at a current pulse duration of 25 ms and an accuracy of $\pm 1 \text{ nm}$.

FORWARD VOLTAGE CLASSIFICATION		
GROUP	FORWARD VOLTAGE (V)	
	MIN.	MAX.
02	2.2	2.5
03	2.5	2.8

Note:

Forward voltages are tested at a current pulse duration of 25 ms and a tolerance of $\pm 0.05 \text{ V}$.

In order to ensure availability, a single forward voltage group can not be ordered.

TYPICAL CHARACTERISTICS

$T_{amb} = 25\text{ }^{\circ}\text{C}$, unless otherwise specified

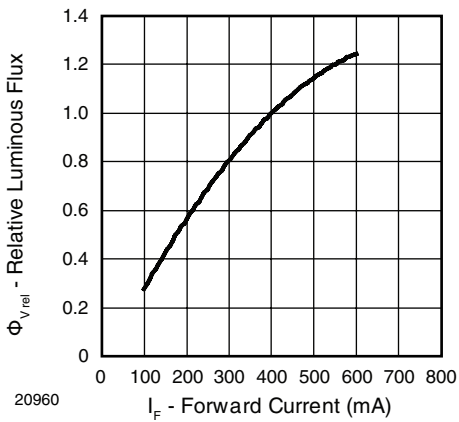

Figure 1. Relative Luminous Flux vs. Forward Current

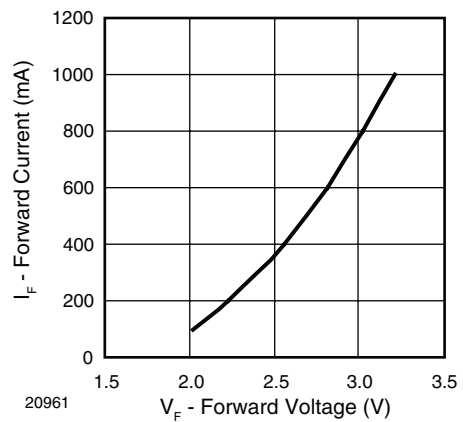

Figure 4. Forward Current vs. Forward Voltage

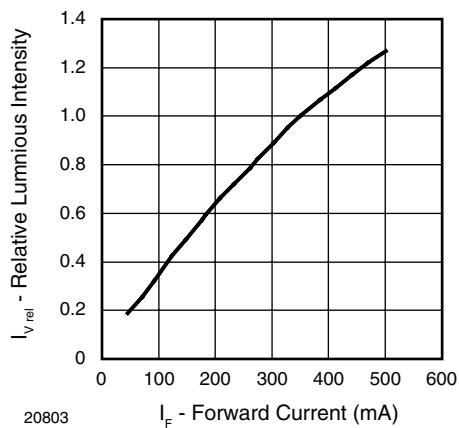

Figure 2. Relative Luminous Intensity vs. Forward Current

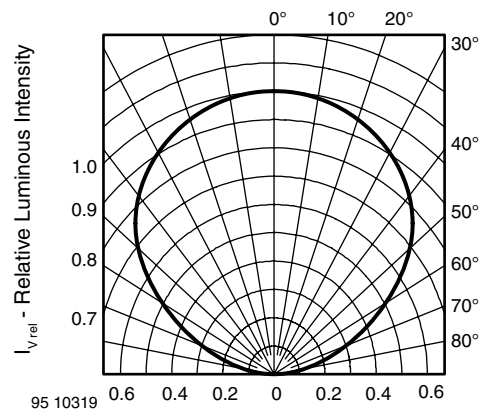

Figure 5. Relative Luminous Intensity vs. Angular Displacement

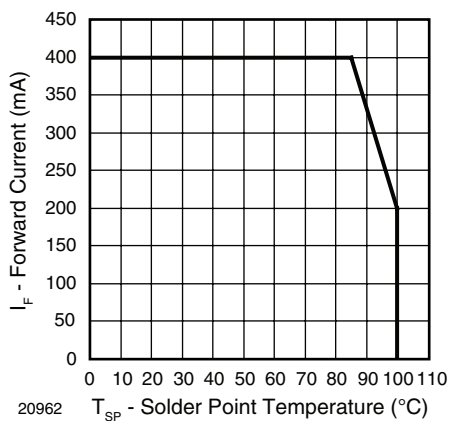
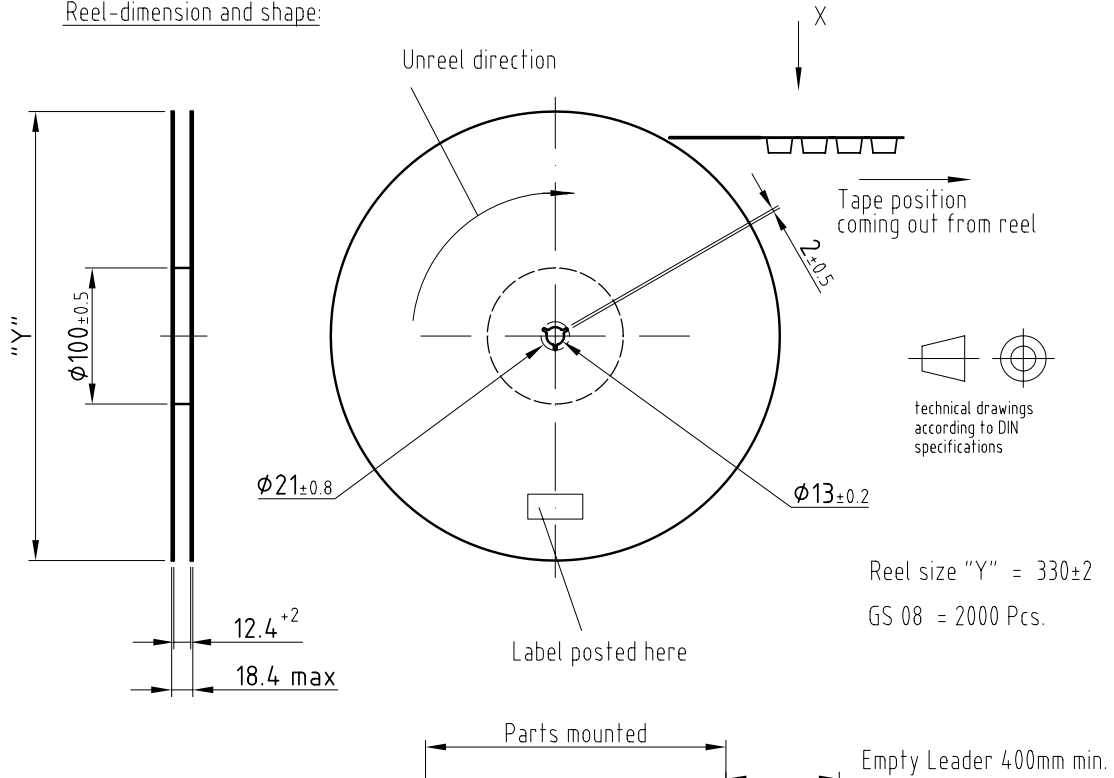

Figure 3. Forward Current vs. Solder Point Temperature

TAPING DIMENSIONS in millimeters

Reel-dimension and shape:



Leader and trailer tape:

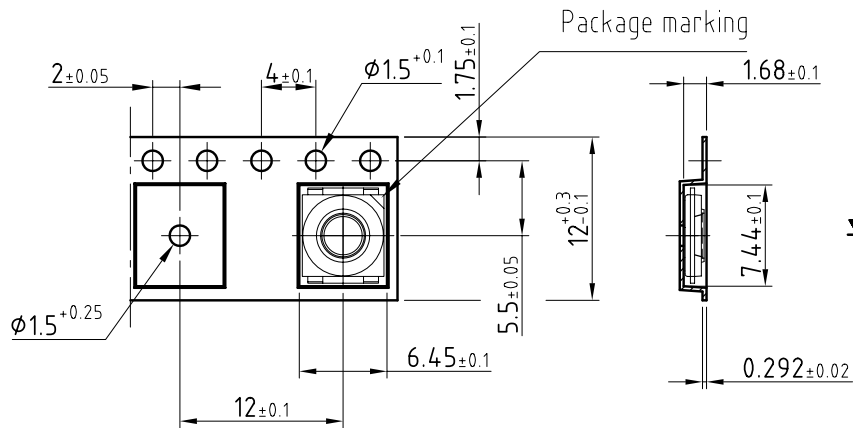

Drawing-No.: 9.800-5094.01-4

Issue: 3; 22.01.08

20846

PACKAGE DIMENSIONS/SOLDERING PADS DIMENSIONS in millimeters

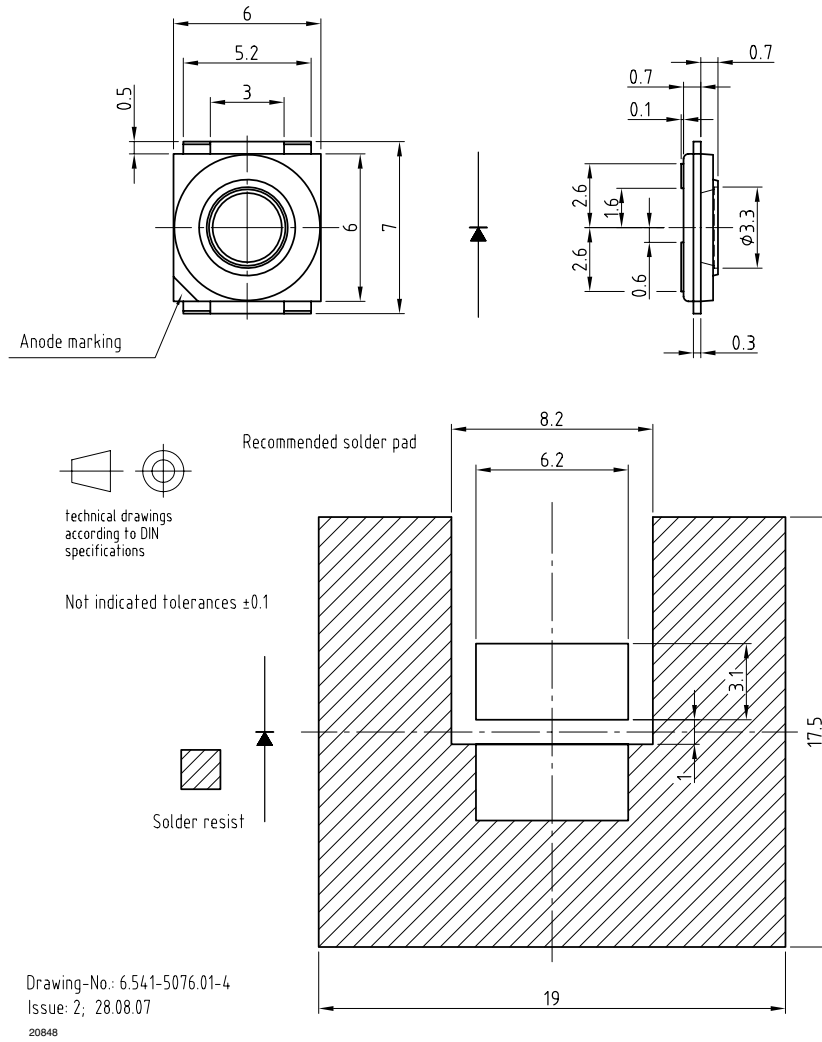

SOLDERING PROFILE

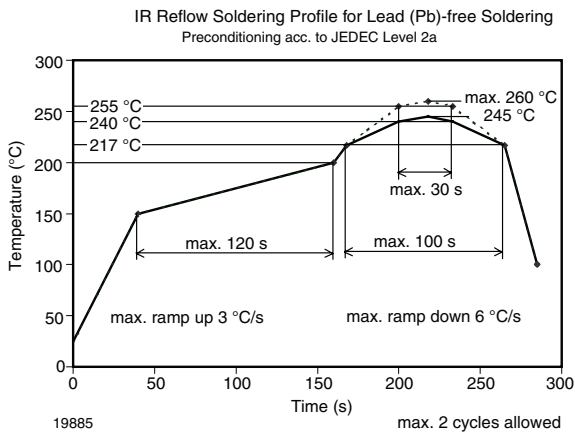
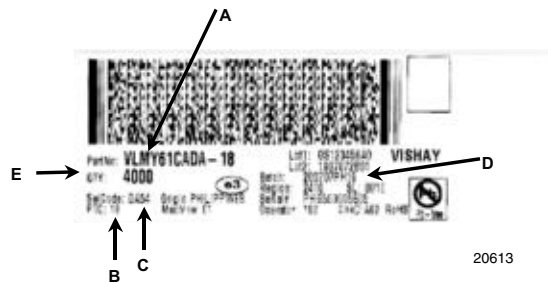

Figure 6. Vishay Lead (Pb)-free Reflow Soldering Profile (acc. to J-STD-020C)

**BAR CODE PRODUCT LABEL
EXAMPLE:**



- A) Type of component
- B) Manufacturing plant
- C) SEL - selection code (bin):
e.g.: DA = code for luminous intensity group
5 = code for color group
4 = code for forward voltage
- D) Batch:
200707 = year 2007, week 07
PH19 = plant code
- E) Total quantity

DRY PACKING

The reel is packed in an anti-humidity bag to protect the devices from absorbing moisture during transportation and storage.

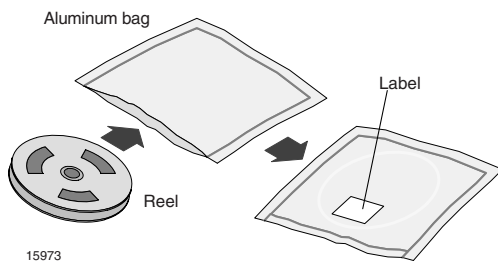

FINAL PACKING

The sealed reel is packed into a cardboard box. A secondary cardboard box is used for shipping purposes.

RECOMMENDED METHOD OF STORAGE

Dry box storage is recommended as soon as the aluminum bag has been opened to prevent moisture absorption. The following conditions should be observed, if dry boxes are not available:

- Storage temperature 10 °C to 30 °C
- Storage humidity ≤ 60 % RH max.

After more than 672 h under these conditions moisture content will be too high for reflow soldering.

In case of moisture absorption, the devices will recover to the former condition by drying under the following condition:

- 192 h at 40 °C + 5 °C/- 0 °C and < 5 % RH (dry air/nitrogen) or
- 96 h at 60 °C + 5 °C and < 5 % RH for all device containers or
- 24 h at 100 °C + 5 °C not suitable for reel or tubes.

An EIA JEDEC standard JESD22-A112 level 2a label is included on all dry bags.

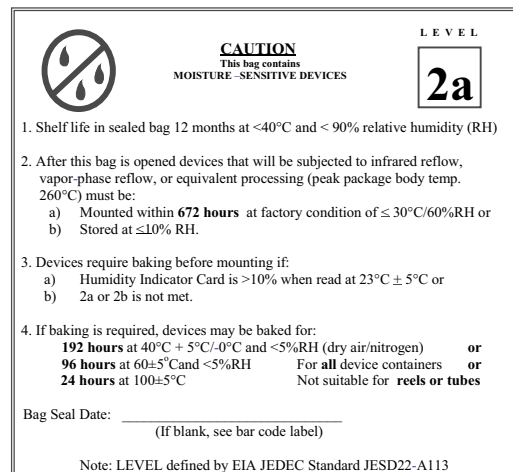

Example of JESD22-A112 level 2a label

ESD PRECAUTION

Proper storage and handling procedures should be followed to prevent ESD damage to the devices especially when they are removed from the antistatic shielding bag. Electro-static sensitive devices warning labels are on the packaging.

**VISHAY SEMICONDUCTORS STANDARD
BAR CODE LABELS**

The Vishay Semiconductors standard bar code labels are printed at final packing areas. The labels are on each packing unit and contain Vishay Semiconductors specific data.

OZONE DEPLETING SUBSTANCES POLICY STATEMENT

It is the policy of Vishay Semiconductor GmbH to

1. Meet all present and future national and international statutory requirements.
2. Regularly and continuously improve the performance of our products, processes, distribution and operating systems with respect to their impact on the health and safety of our employees and the public, as well as their impact on the environment.

It is particular concern to control or eliminate releases of those substances into the atmosphere which are known as ozone depleting substances (ODSs).

The Montreal Protocol (1987) and its London Amendments (1990) intend to severely restrict the use of ODSs and forbid their use within the next ten years. Various national and international initiatives are pressing for an earlier ban on these substances.

Vishay Semiconductor GmbH has been able to use its policy of continuous improvements to eliminate the use of ODSs listed in the following documents.

1. Annex A, B and list of transitional substances of the Montreal Protocol and the London Amendments respectively.
2. Class I and II ozone depleting substances in the Clean Air Act Amendments of 1990 by the Environmental Protection Agency (EPA) in the USA.
3. Council Decision 88/540/EEC and 91/690/EEC Annex A, B and C (transitional substances) respectively.

Vishay Semiconductor GmbH can certify that our semiconductors are not manufactured with ozone depleting substances and do not contain such substances.

The IEC/EN standards require that the desired classification Accessible Emission Limit shall not be exceeded in "Normal" and "Single Fault Conditions". This product is in Compliance with the requirement in CEN/IEC/EN60825-1 to ensure that required classifications are not exceeded in single fault conditions.

We reserve the right to make changes to improve technical design
and may do so without further notice.

Parameters can vary in different applications. All operating parameters must be validated for each customer application by the customer. Should the buyer use Vishay Semiconductors products for any unintended or unauthorized application, the buyer shall indemnify Vishay Semiconductors against all claims, costs, damages, and expenses, arising out of, directly or indirectly, any claim of personal damage, injury or death associated with such unintended or unauthorized use.

Vishay Semiconductor GmbH, P.O.B. 3535, D-74025 Heilbronn, Germany



Disclaimer

All product specifications and data are subject to change without notice.

Vishay Intertechnology, Inc., its affiliates, agents, and employees, and all persons acting on its or their behalf (collectively, "Vishay"), disclaim any and all liability for any errors, inaccuracies or incompleteness contained herein or in any other disclosure relating to any product.

Vishay disclaims any and all liability arising out of the use or application of any product described herein or of any information provided herein to the maximum extent permitted by law. The product specifications do not expand or otherwise modify Vishay's terms and conditions of purchase, including but not limited to the warranty expressed therein, which apply to these products.

No license, express or implied, by estoppel or otherwise, to any intellectual property rights is granted by this document or by any conduct of Vishay.

The products shown herein are not designed for use in medical, life-saving, or life-sustaining applications unless otherwise expressly indicated. Customers using or selling Vishay products not expressly indicated for use in such applications do so entirely at their own risk and agree to fully indemnify Vishay for any damages arising or resulting from such use or sale. Please contact authorized Vishay personnel to obtain written terms and conditions regarding products designed for such applications.

Product names and markings noted herein may be trademarks of their respective owners.

Компания «Океан Электроники» предлагает заключение долгосрочных отношений при поставках импортных электронных компонентов на взаимовыгодных условиях!

Наши преимущества:

- Поставка оригинальных импортных электронных компонентов напрямую с производств Америки, Европы и Азии, а так же с крупнейших складов мира;
- Широкая линейка поставок активных и пассивных импортных электронных компонентов (более 30 млн. наименований);
- Поставка сложных, дефицитных, либо снятых с производства позиций;
- Оперативные сроки поставки под заказ (от 5 рабочих дней);
- Экспресс доставка в любую точку России;
- Помощь Конструкторского Отдела и консультации квалифицированных инженеров;
- Техническая поддержка проекта, помощь в подборе аналогов, поставка прототипов;
- Поставка электронных компонентов под контролем ВП;
- Система менеджмента качества сертифицирована по Международному стандарту ISO 9001;
- При необходимости вся продукция военного и аэрокосмического назначения проходит испытания и сертификацию в лаборатории (по согласованию с заказчиком);
- Поставка специализированных компонентов военного и аэрокосмического уровня качества (Xilinx, Altera, Analog Devices, Intersil, Interpoint, Microsemi, Actel, Aeroflex, Peregrine, VPT, Syfer, Eurofarad, Texas Instruments, MS Kennedy, Miteq, Cobham, E2V, MA-COM, Hittite, Mini-Circuits, General Dynamics и др.);

Компания «Океан Электроники» является официальным дистрибьютором и эксклюзивным представителем в России одного из крупнейших производителей разъемов военного и аэрокосмического назначения «JONHON», а так же официальным дистрибьютором и эксклюзивным представителем в России производителя высокотехнологичных и надежных решений для передачи СВЧ сигналов «FORSTAR».



JONHON

«JONHON» (основан в 1970 г.)

Разъемы специального, военного и аэрокосмического назначения:

(Применяются в военной, авиационной, аэрокосмической, морской, железнодорожной, горно- и нефтедобывающей отраслях промышленности)

«FORSTAR» (основан в 1998 г.)

ВЧ соединители, коаксиальные кабели,
кабельные сборки и микроволновые компоненты:

(Применяются в телекоммуникациях гражданского и специального назначения, в средствах связи, РЛС, а так же военной, авиационной и аэрокосмической отраслях промышленности).



Телефон: 8 (812) 309-75-97 (многоканальный)

Факс: 8 (812) 320-03-32

Электронная почта: ocean@oceanchips.ru

Web: <http://oceanchips.ru/>

Адрес: 198099, г. Санкт-Петербург, ул. Калинина, д. 2, корп. 4, лит. А