

HFBR-14xxZ and HFBR-24xxZ Series



Low-Cost, 820 nm Miniature Link Fiber Optic Components with ST, SMA, SC, and FC Ports

Data Sheet



Description

The 820 nm Miniature Link Series of components is designed to provide cost-effective, high-performance fiber optic communication links for information systems and industrial applications with link distances of several kilometers. With the HFBR-24x6Z, the 125 MHz analog receiver, data rates of up to 160 MBaud can be attained.

Transmitters and receivers are directly compatible with popular “industry-standard” connectors: ST, SMA, SC, and FC. They are completely specified with multiple fiber sizes; including 50/125 μm , 62.5/125 μm , 100/140 μm , and 200 μm .

Products are available in various options. For example, transmitters with the improved protection option P show an increased ESD resistance to the pins. This HFBR-141xPxZ integrated solution is realized by including a Zener diode parallel to the LED.

The HFBR-14x4Z high-power transmitter and HFBR-24x6Z 125 MHz receiver pair up to provide a duplex solution optimized for 100BASE-SX. 100BASE-SX is a Fast Ethernet Standard (100 Mb/s) at 850 nm on multimode fiber.

Evaluation kits are available for ST products, including transmitter, receiver, eval board, and technical literature.

Features

- RoHS compliant
- Low-cost transmitters and receivers
- Choice of ST, SMA, SC, or FC ports
- 820 nm wavelength technology
- Signal rates up to 160 MBaud
- Link distances up to several kilometers
- Compatible with 50/125 μm , 62.5/125 μm , 100/140 μm , and 200 μm Plastic-Clad Silica (PCS) Fiber
- Repeatable ST connections within 0.2 dB typical
- Unique optical port design for efficient coupling
- Pick and place, and wave solderable
- No board-mounting hardware required
- Wide operating temperature range -40°C to $+85^{\circ}\text{C}$
- Conductive port option

Applications

- 100BASE-SX Fast Ethernet on 850 nm
- Media/fiber conversion, switches, routers, hubs, and NICs on 100BASE-SX
- Local area networks
- Computer-to-peripheral links and computer monitor links
- Digital cross connect links
- Central office switch/PBX links
- Video links
- Modems and multiplexers
- Suitable for Tempest systems
- Industrial control links

Part Number Guide



Available Options

HFBR-1402Z	HFBR-1404Z	HFBR-1412PTZ	HFBR-1412PZ	HFBR-1412TMZ	HFBR-1412TZ
HFBR-1412Z	HFBR-1414PTZ	HFBR-1414PZ	HFBR-1414MZ	HFBR-1414TZ	HFBR-1414Z
HFBR-1415PMZ	HFBR-1415TZ	HFBR-1415Z	HFBR-1424Z	HFBR-14E4Z	HFBR-2402Z
HFBR-2406Z	HFBR-2412TCZ	HFBR-2412TZ	HFBR-2412Z	HFBR-2416MZ	HFBR-2416TCZ
HFBR-2416TZ	HFBR-2416Z	HFBR-2422Z	HFBR-24E2Z	HFBR-24E6Z	
AFBR-2408Z	AFBR-2418Z	AFBR-2418TZ	AFBR-2418MZ	AFBR-2409Z	AFBR-2419Z
AFBR-2419TZ	AFBR-2419MZ				

Note: For better readability of the electrical and optical specifications, all available options (P, T, C, and M) are covered by the HFBR-x4xxZ product name; exceptions are explicitly noted.

Note: AFBR-24x8xZ receivers are designed for data rates from DC up to 50 MBaud. AFBR-24x9xZ supports transmissions from 100 KBaud up to 50 MBaud. Refer to the separate data sheets for details about these digital optical receivers providing CMOS/TTL output logic.

Link Selection Guide

For additional information about specific links, see the individual link descriptions. The HFBR-1415Z can be used for increased power budget or for lower driving current for the same Data Rates and Link Distances.

Data Rate (MBaud) ¹	Distance (m)	Transmitter	Receiver	Fiber Size (µm)	Evaluation Kit
DC to 5	1500	HFBR-14x2Z	HFBR-24x2Z	62.5/125	HFBR-0410Z
20	2700	HFBR-14x4Z/14x5Z	HFBR-24x6Z	62.5/125	HFBR-0416Z
20 to 32	2200	HFBR-14x4Z/14x5Z	HFBR-24x6Z	62.5/125	HFBR-0416Z
DC to 50	2000	HFBR-14x4Z/14x5Z	AFBR-24x8xZ	62.5/125	AFBR-0549Z
0.1 to 50	1000	HFBR-14x4Z/14x5Z	AFBR-24x9xZ	62.5/125	AFBR-0550Z
20 to 55	1400	HFBR-14x4Z/14x5Z	HFBR-24x6Z	62.5/125	HFBR-0416Z
20 to 125	700	HFBR-14x4Z/14x5Z	HFBR-24x6Z	62.5/125	HFBR-0416Z
20 to 155	600	HFBR-14x4Z/14x5Z	HFBR-24x6Z	62.5/125	HFBR-0416Z
20 to 160	500	HFBR-14x4Z/14x5Z	HFBR-24x6Z	62.5/125	HFBR-0416Z

1. The data rate range in the table refers to the evaluation kit documentation. For an analog receiver, like the HFBR-24x6Z, the data rate range depends on the receiver circuit used.

Options

In addition to the various port styles available for the HFBR-0400Z series products, there are also several extra options that can be ordered. To order an option, simply place the corresponding option number at the end of the part number. See page 2 for available options.

Option P (Protection improved option)

- Designed to withstand electrostatic discharge (ESD) of 2 kV (HBM) to the pins
- Available on TX with non-conductive ST and non-conductive threaded ST ports

Option T (Threaded Port Option)

- Allows ST style port components to be panel mounted
- Compatible with all current makes of ST multimode connectors
- Mechanical dimensions are compliant with MIL-STD- 83522/13
- Maximum wall thickness when using nuts and washers from the HFBR-4411Z hardware kit is 2.8 mm (0.11 inch)
- Available on all ST ports

Option C (Conductive Port Receiver Option)

- Designed to withstand electrostatic discharge (ESD) of 25 kV to the optical port
- Significantly reduces effect of electromagnetic interference (EMI) on receiver sensitivity
- Allows designer to separate the signal and conductive port grounds
- Recommended for use in noisy environments
- Available on threaded ST port style receivers only
- The conductive port is connected to Pins 1, 4, 5, and 8 through the Port Grounding Path Insert

Option M (Metal Port Option)

- Nickel plated aluminum connector receptacle
- Designed to withstand electrostatic discharge (ESD) of 15 kV to the optical port
- Significantly reduces effect of electromagnetic interference (EMI) on receiver sensitivity
- Allows designer to separate the signal and metal port grounds
- Recommended for use in very noisy environments
- Available on ST and threaded ST ports
- The metal port is connected to Pins 1, 4, 5, and 8 through the Port Grounding Path Insert

Applications Support Guide

This section gives the designer information necessary to use the 820 nm Miniature Link Series components to make a functional optical transmission link.

Broadcom offers evaluation kits for hands-on experience with fiber optic products as well as a wide range of application notes complete with circuit diagrams and board layouts.

Furthermore, Broadcom's application support group is always ready to assist with any design consideration.

Application Literature

Title	Description
Application Note 1065	Complete Solutions for IEEE 802.5J Fiberoptic Token Ring
Application Note 1121	DC to 32 MBaud Fiberoptic Solutions
Application Note 1122	2 to 70 MBaud Fiberoptic Solutions
Application Note 1123	20 to 160 MBaud Fiberoptic Solutions
Application Note 1137	Generic Printed Circuit Layout Rules

Evaluation Kits

Broadcom offers fiber optic kits that facilitate a simple means to evaluate and experience our products. These fiber optic kits contain all the components and tools required for customers to quickly evaluate and access the value of our products within their respective applications.

HFBR-0410Z ST Evaluation Kit: DC to 5 MBaud 820 nm Fiber Optic Eval Kit

Contains the following:

- One HFBR-1412Z transmitter
- One HFBR-2412Z receiver
- Eval board
- Related literature

HFBR-0416Z Evaluation Kit: 125 MBaud 820 nm Fiber Optic Eval Kit

Contains the following:

- One HFBR-1414Z transmitter
- One HFBR-2416Z receiver
- Eval board
- Related literature

AFBR-0549Z Evaluation Kit: DC to 50 MBaud 820 nm Fiber Optic Eval Kit

Contains the following:

- One HFBR-1414PTZ transmitter
- One AFBR-2418TZ receiver
- Eval board
- Related literature

AFBR-0550Z Evaluation Kit: Up to 50 MBaud 820 nm Fiber Optic Eval Kit

Contains the following:

- One HFBR-1414PTZ transmitter
- One AFBR-2419TZ receiver
- Eval board
- Related literature

Package and Handling Information

Package Information

All transmitters and receivers of the 820 nm Miniature Link Series are housed in a low-cost, dual-inline package that is made of high strength, heat resistant, chemically resistant, and UL 94V-O flame retardant plastic (UL File #E121562). The transmitters are easily identified by the light grey color connector port. The receivers are easily identified by the dark grey color connector port. (Black color for conductive port). The package is designed for pick and place and wave soldering so it is ideal for high volume production applications.

Handling and Design Information

Each part comes with a protective port cap or plug covering the optics. Note: This plastic or rubber port cap is made to protect the optical path during assembly. It is not meant to remain on the part for a long period. These caps/plugs will vary by port style. When soldering, it is advisable to leave the protective cap on the unit to keep the optics clean. Good system performance requires clean port optics and cable ferrules to avoid obstructing the optical path.

Clean compressed air often is sufficient to remove particles of dirt; methanol on a cotton swab also works well.

Recommended Chemicals for Cleaning/Degreasing 820 nm Miniature Link Products

Alcohols: methyl, isopropyl, isobutyl.

Aliphatics: hexane, heptane, Other: soap solution, naphtha.

Do not use partially halogenated hydrocarbons (such as 1.1.1 trichloroethane), ketones (such as MEK), acetone, chloroform, ethyl acetate, methylene dichloride, phenol, methylene chloride, or N-methylpyrrolidone. Also, Broadcom does not recommend the use of cleaners that use halogenated hydrocarbons because of their potential environmental harm.

Mechanical Dimensions (SMA Port)

HFBR-x40xZ



Dimensions in mm (inches)

Mechanical Dimensions (ST Port)

HFBR-x41xZ



Dimensions in mm (inches)

Mechanical Dimensions (Metal ST Port)

HFBR-x41xMZ

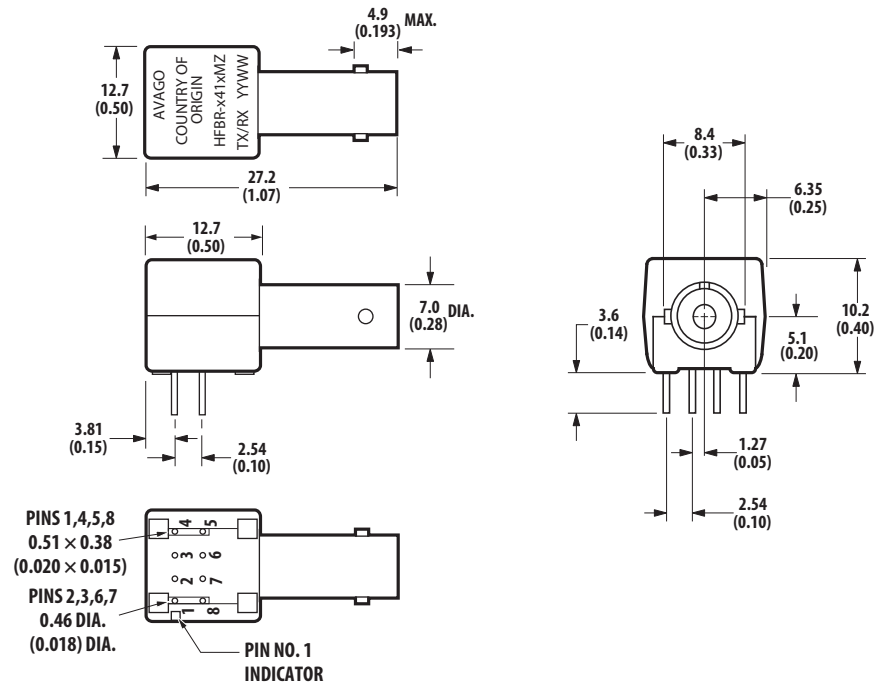

Mechanical Dimensions (Threaded ST Port)

HFBR-x41xTZ

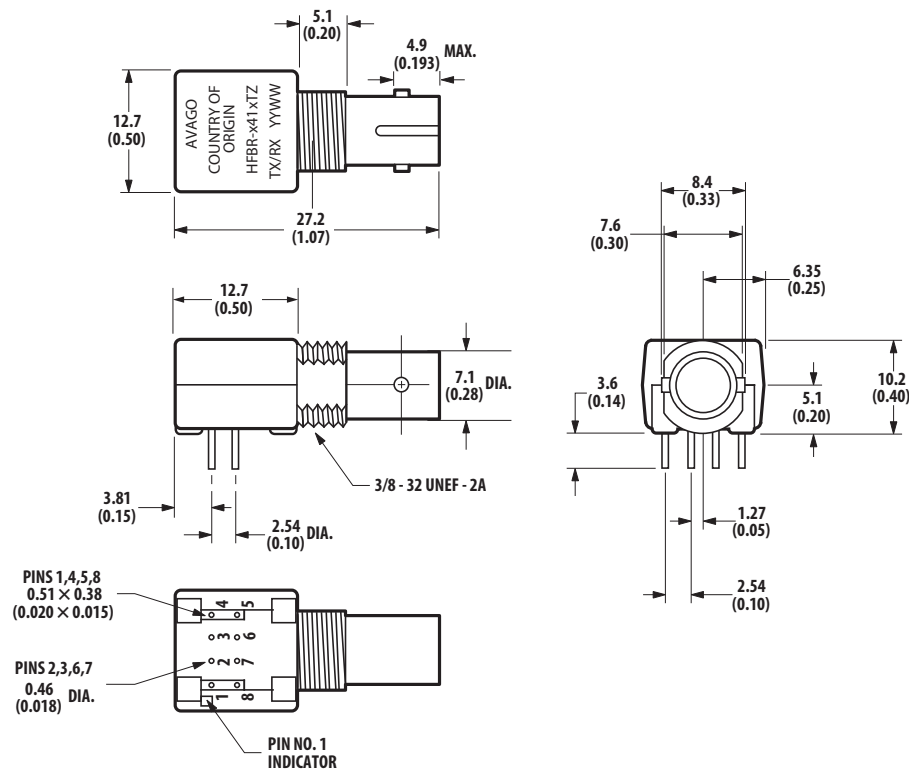

Mechanical Dimensions (FC Port)

HFBR-x42xZ

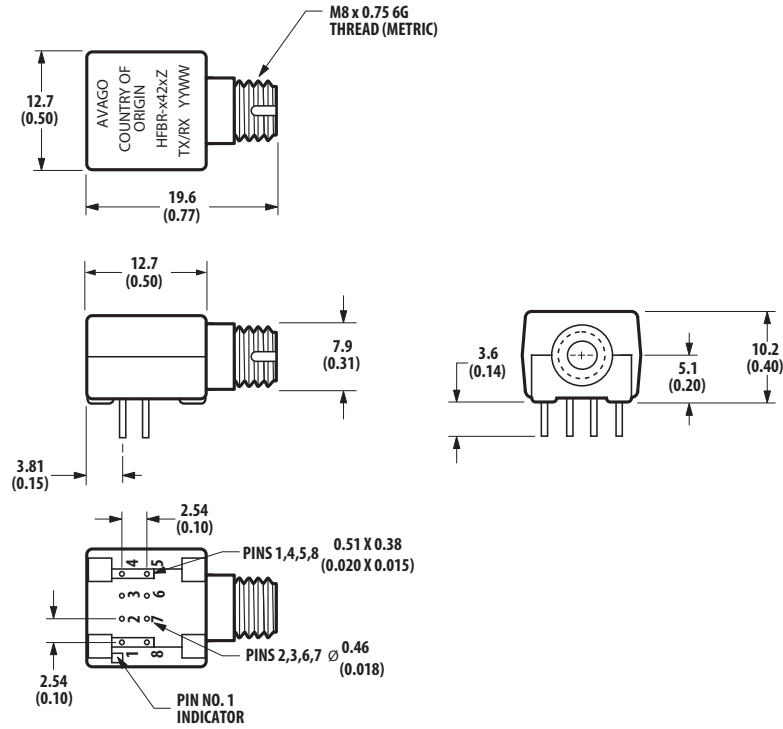

Dimensions in mm (inches)

Mechanical Dimensions (SC Port)

HFBR-x4ExZ



Dimensions in mm (inches)

Cross-Sectional View



Figure 1: HFBR-x41xTZ ST Series Cross-Sectional View

Panel Mount Hardware



(Each HFBR-4401Z and HFBR-4411Z kit consists of 100 nuts and 100 washers).

Dimensions in mm (inches)

Port Cap Hardware

HFBR-4402Z: 500 SMA Port Caps

HFBR-4120Z: 500 ST Port Plugs

Typical Link Data

The following technical data is taken from 5 MBaud and 155 MBaud link using the 820 nm Miniature Link Series. This data is meant to be regarded as an example of typical link performance for a given design and does not call out any link limitations.

5 MBaud Link (HFBR-14xxZ/24x2Z)

Link Performance –40°C to +85°C unless otherwise specified

Parameter	Symbol	Min.	Typ.	Max.	Unit	Conditions	Reference
Optical Power Budget with 50/125 μm fiber	OPB ₅₀	4.2	9.6		dB	HFBR-14x4Z/24x2Z NA = 0.2	Note 1
Optical Power Budget with 62.5/125 μm fiber	OPB _{62.5}	8.0	15		dB	HFBR-14x4Z/24x2Z NA = 0.27	Note 1
Optical Power Budget with 100/140 μm fiber	OPB ₁₀₀	8.0	15		dB	HFBR-14x2Z/24x2Z NA = 0.30	Note 1
Optical Power Budget with 200 μm fiber	OPB ₂₀₀	13.0	20		dB	HFBR-14x2Z/24x2Z NA = 0.37	Note 1
Data Rate		DC		5	Mbaud		Note 2
Propagation Delay LOW to HIGH	t_{PLH}		72		ns	$T_A = +25^\circ\text{C}$ $P_R = -21$ dBm peak Fiber cable length = 1 m	Figures 6, 7, 8
Propagation Delay HIGH to LOW	t_{PHL}		46		ns		
System Pulse Width Distortion	$t_{\text{PLH}} - t_{\text{PHL}}$		26		ns		
Bit Error Rate	BER			10^{-9}		Data rate < 5 Mbaud $P_R > -24$ dBm peak	

Notes:

- Optical Power Board at $T_A = -40^\circ\text{C}$ to $+85^\circ\text{C}$, $V_{CC} = 5.0V_{dc}$, $I_F \text{ ON} = 60$ mA. $P_R = -24$ dBm peak.
- Data rate limit is based on these assumptions:
 - 50% duty factor modulation, e.g., Manchester I or BiPhase Manchester II
 - Continuous data
 - PLL Phase Lock Loop demodulation
 - TTL threshold.

5 MBaud Logic Link Design

The resistor R1 is the only significant element in the drive circuit (see Figure 2) that limits the current through the LED, apart from the gate’s output port. Depending on the actual gate used, the voltage drop on the output port V_{port} could be neglected. The forward voltage value, V_F , of the LED depends on the desired LED current and on the temperature (see Figure 9). Make sure you take this behavior into account for the calculations.

The curves in Figure 3, Figure 4, and Figure 5 are constructed assuming no inline splice or any additional system loss. Besides fiber attenuation, for correct power budget calculation, make sure you take into account the effect of bending, humidity, ambient temperature, aging and other relevant influences. All these additional losses reduce the achievable link distance accordingly.

For calculating the LED’s aging effect, an additional loss of about 1.5 dB is recognized.

The following example will illustrate the technique for selecting the appropriate value of I_F and R1:

$$R_1 = \frac{V_{CC} - V_F}{I_F}$$

Maximum distance required = 2000 meters by using HFBR-14x4Z/24x2Z logic link with 62.5/125 μ m fiber.

Figure 4 shows the “worst-case” drive current of about 43 mA for reaching a distance of about 2000 meters.

Figure 9 shows the transmitter forward voltage of about $V_F = 1.62V$. If the typical circuit configuration (Figure 2) is used at $V_{CC} = 5.0V$, the resistor value “R1” should be chosen to 78.6 Ω (3.38 V/43 mA) for reaching driver current of about 43 mA.

Page 16 shows the guaranteed HFBR-14x4Z’s optical output power limit of -16.0 dBm (for driver current of 60 mA) over the entire temperature range.

Figure 10 shows the normalized typical output power. When the transmitter will be driven with 43 mA the optical output power is about 0.70 or -1.55 dB lower than at 60 mA.

With an assumed fiber attenuation of 3.2 dB/km and the reduced driver current of 43 mA, the minimum optical output power at fiber end is about -24 dBm, which is equal to the receiver sensitivity over the entire temperature range.

For balancing the individual additional system losses, the driver current must be increased accordingly.

Figure 2. Typical Circuit Configuration



Note:
A bypass capacitor (0.01 μ F to 0.1 μ F ceramic) must be connected from pin 2 to pin 7 of the receiver. Total lead length between both ends of the capacitor and the pins should not exceed 20 mm.

The following diagrams (Figure 3 to Figure 5) serve as an aid in Link Design and are based on theoretical calculations. For broad use, no additional effects such as aging were taken into account. The additional losses and the individual safety buffer values should be added separately. These diagrams reflect the pure viewing of power budget and do not allows conclusions about the actual link quality.

Overdrive: Maximum optical output power of Tx combined with receiver sensitivity of -10 dBm over the entire temperature range.

Typical 25°C: Typical optical output power of Tx combined with receiver sensitivity of -25.4 dBm at $T_A = 25^\circ C$.

Worst Case: Minimum optical output power of Tx combined with receiver sensitivity of -24 dBm over the entire temperature range.

Figure 3: Typical HFBR-14x4xZ/HFBR-24x2xZ Link with 100/140 μm Fiber

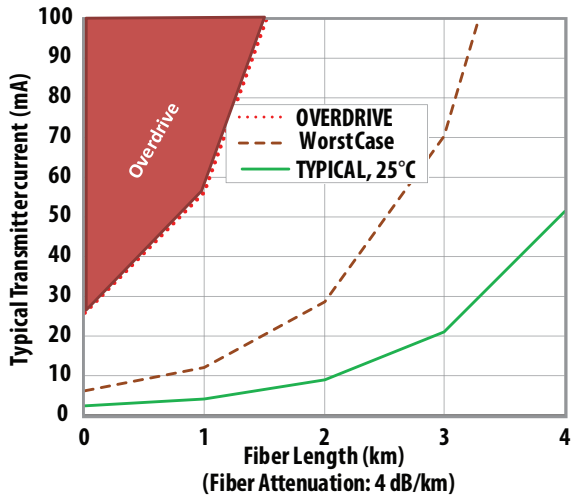

Figure 4: Typical HFBR-14x4xZ/HFBR-24x2xZ Link with 62.5/125 μm Fiber

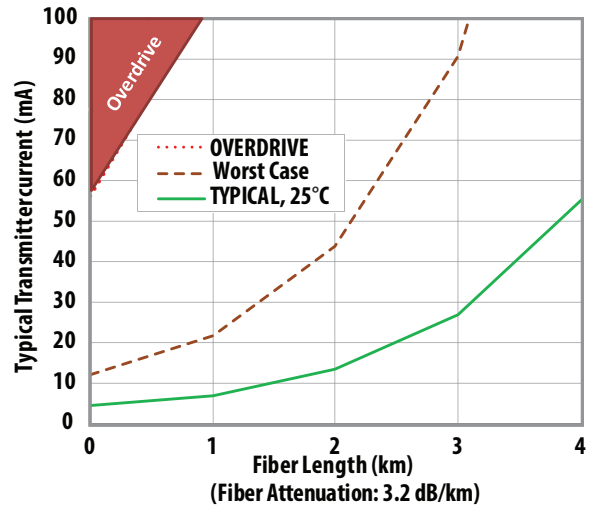

Figure 5: Typical HFBR-14x4xZ/HFBR-24x2xZ Link with 50/125 μm Fiber



Figure 6: Typical Propagation Delay Times of Link (HFBR-14x4Z/HFBR-24x2Z) measured at T_A=25°C, 5 MBaud, and with 1m of Cable

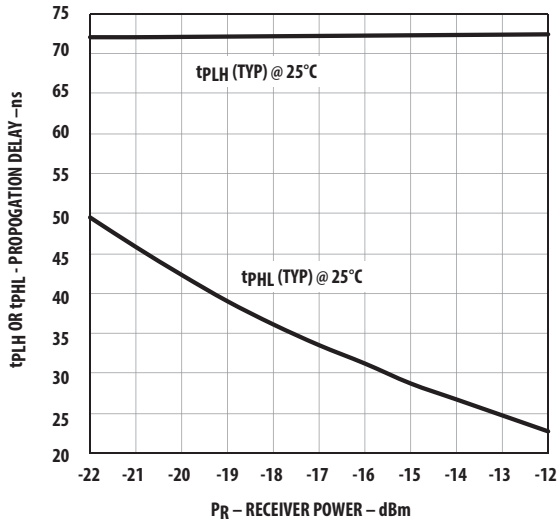

Figure 7: Typical Pulse Width Distortion of Link (HFBR-14x4Z/HFBR-24x2Z) measured at T_A=25°C, 5 MBaud, and with 1m of Cable

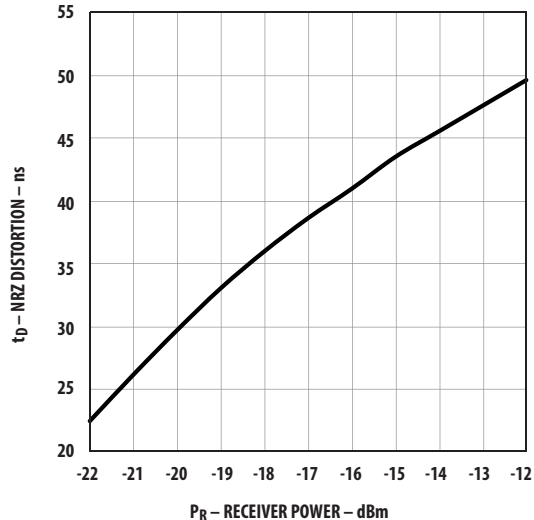
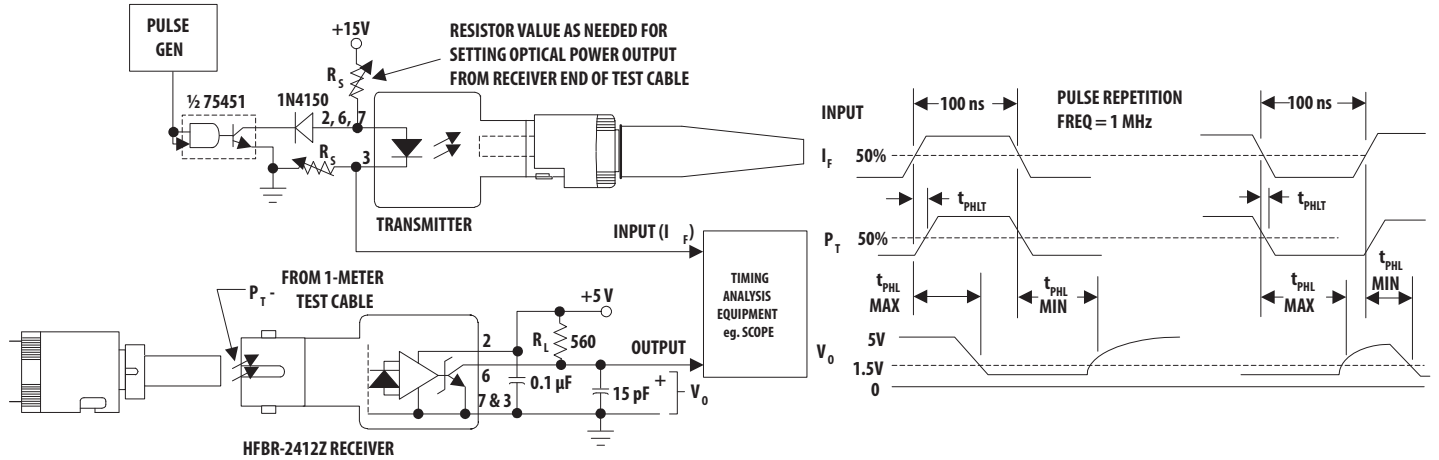

Figure 8: System Propagation Delay Test Circuit and Waveform Timing Definitions



155 MBaud Link (HFBR-14x4Z/24x6Z)

Typical Link Performance

Parameter	Symbol	Min.	Typ. [1, 2]	Max.	Unit	Conditions	Reference
Optical Power Budget with 50/125 μm fiber	OPB ₅₀		13.9		dB	NA = 0.2	Note 2
Optical Power Budget with 62.5/125 μm fiber	OPB ₆₂		17.7		dB	NA = 0.27	
Optical Power Budget with 100/140 μm fiber	OPB ₁₀₀		17.7		dB	NA = 0.30	
Optical Power Budget with 200 μm PCS fiber	OPB ₂₀₀		22.0		dB	NA = 0.35	
Data Format 20% to 80% Duty Factor		20		160	MBaud		
System Pulse Width Distortion	$ t_{PLH} - t_{PHL} $		1		ns	PR = -7 dBm peak 1 m 62.5/125 μm fiber	
Bit Error Rate	BER		10^{-9}			Data rate < 100 MBaud PR > -31 dBm peak	Note 2

Notes:

1. Typical data at $T_A = +25^\circ\text{C}$, $V_{CC} = 5.0\text{V}_{dc}$, PECL serial interface.
2. Typical OPB was determined at a probability of error (BER) of 10^{-9} . Lower probabilities of error can be achieved with short fibers that have less optical loss.

HFBR-14x2Z/14x4Z/14x5Z Low-Cost High-Speed Transmitters

Description

The HFBR-14xxZ fiber optic transmitter contains an 820 nm AlGaAs emitter capable of efficiently launching optical power into four different optical fiber sizes: 50/125 μm , 62.5/125 μm , 100/140 μm , and 200 μm Plastic-Clad Silica (PCS). This allows the designer flexibility in choosing the fiber size. The HFBR-14xxZ is designed to operate with the Broadcom Ltd. HFBR-24xxZ fiber optic receivers.

The HFBR-14xxZ transmitter’s high coupling efficiency allows the emitter to be driven at low current levels resulting in low power consumption and increased reliability of the transmitter. The HFBR-14x4Z high power transmitter is optimized for small size fiber and typically can launch -15.8 dBm optical power at 60 mA into 50/125 μm fiber and -12 dBm into 62.5/125 μm fiber. The HFBR-14x2Z standard transmitter typically can launch -12 dBm of optical power at 60 mA into 100/140 μm fiber cable. It is ideal for large size fiber such as 100/140 μm . The high launched optical power level is useful for systems where star couplers, taps, or inline connectors create large fixed losses.

For 820 nm Miniature Link transmitters with protection improved option “P” a Zener diode parallel to the LED was implemented. Therefore, a higher ESD capability could be attained.

Note: Parameters “reverse input voltage” and “diode capacitance” for “HFBR-141xPxZ” transmitters deviate from the non P-parts.

Consistent coupling efficiency is assured by the double-lens optical system (Figure 1 on page 9). Power coupled into any of the three fiber types varies less than 5 dB from part to part at a given drive current and temperature. Consistent coupling efficiency reduces receiver dynamic range requirements, which allows for longer link lengths.

Housed Product



- NOTES:
 1. PINS 1, 4, 5, AND 8 ARE ELECTRICALLY CONNECTED.
 2. PINS 2, 6, AND 7 ARE ELECTRICALLY CONNECTED TO THE HEADER.

Regulatory Compliance - Targeted Specifications

Feature	Performance	Reference
Electrostatic Discharge (ESD)	Class 1C (>1000V, <2000V) - Human Body Model	Note 1, 4
	Class 1B (>500V, <1000V) - Human Body Model	Note 1, 2

Absolute Maximum Ratings

Parameter	Symbol	Min.	Max.	Unit	Reference
Storage Temperature	T _S	-55	+85	°C	
Operating Temperature	T _A	-40	+85	°C	
Lead Soldering Cycle					
Temp			+260	°C	
Time			10	sec	
Forward Input Current					
Peak	I _{FPK}		200	mA	Note 3
dc	I _{Fdc}		100	mA	
Reverse Input Voltage	VBR		1.8	V	
			0.3	V	Note 4

- Notes:
 1. ESD capability for all pins HBM (Human Body Model) according JEDEC JESD22-A114.
 2. Valid for not protection improved transmitter option
 3. For I_{FPK} > 100 mA, the time duration should not exceed 2 ns.
 4. Only valid for HFBR-141xPxZ (Protection improved option).

Electrical/Optical Specifications

–40°C to +85°C unless otherwise specified.

Parameter	Symbol	Min.	Typ. [2]	Max.	Unit	Conditions	Reference
Forward Voltage	V_F	1.48	1.70	2.09	V	$I_F = 60$ mA dc	Figure 9
			1.84			$I_F = 100$ mA dc	
Forward Voltage Temperature Coefficient	$\Delta V_F/\Delta T$		–0.22		mV/K	$I_F = 60$ mA dc	Figure 9
			–0.18			$I_F = 100$ mA dc	
Reverse Input Voltage	V_{BR}	1.8	3.8		V	$I_F = -100$ μ A dc	
		0.3	0.7		V	$I_F = -100$ μ A dc	Note 10
Peak Emission Wavelength	λ_P	792	820	865	nm		
Diode Capacitance	C_T		55		pF	$V = 0, f = 1$ MHz	
			70		pF	$V = 0, f = 1$ MHz	Note 10
Optical Power Temperature Coefficient	$\Delta P_T/\Delta T$		–0.006		dB/K	$I = 60$ mA dc	
			–0.010			$I = 100$ mA dc	
Thermal Resistance	Θ_{JA}		490		K/W		Notes 3, 8
14x2Z Numerical Aperture	NA		0.49				
14x4Z Numerical Aperture	NA		0.31				
14x2Z Optical Port Diameter	D		290		μ m		Note 4
14x4Z Optical Port Diameter	D		150		μ m		Note 4

HFBR-14x2Z Output Power Measured Out of 1 Meter of Cable

Parameter	Symbol	Min.	Typ.	Max.	Unit	Conditions	Reference
50/125 μ m Fiber Cable	P_{T50}	–21.8	–18.8	–16.8	dBm peak	$T_A = +25^\circ\text{C}, I_F = 60$ mA	Notes 5, 6, 9 Figure 10
		–22.8		–15.8	dBm peak	$T_A = -40^\circ\text{C to } +85^\circ\text{C}, I_F = 60$ mA	
		–20.3	–16.8	–14.4	dBm peak	$T_A = +25^\circ\text{C}, I_F = 100$ mA	
		–21.9		–13.8	dBm peak	$T_A = -40^\circ\text{C to } +85^\circ\text{C}, I_F = 100$ mA	
62.5/125 μ m Fiber Cable	P_{T62}	–19.0	–16.0	–14.0	dBm peak	$T_A = +25^\circ\text{C}, I_F = 60$ mA	
		–20.0		–13.0	dBm peak	$T_A = -40^\circ\text{C to } +85^\circ\text{C}, I_F = 60$ mA	
		–17.5	–14.0	–11.6	dBm peak	$T_A = +25^\circ\text{C}, I_F = 100$ mA	
		–19.1		–11.0	dBm peak	$T_A = -40^\circ\text{C to } +85^\circ\text{C}, I_F = 100$ mA	
100/140 μ m Fiber Cable	P_{T100}	–15.0	–12.0	–10	dBm peak	$T_A = +25^\circ\text{C}, I_F = 60$ mA	
		–16.0		–9.0	dBm peak	$T_A = -40^\circ\text{C to } +85^\circ\text{C}, I_F = 60$ mA	
		–13.5	–10.0	–7.6	dBm peak	$T_A = +25^\circ\text{C}, I_F = 100$ mA	
		–15.1		–7.0	dBm peak	$T_A = -40^\circ\text{C to } +85^\circ\text{C}, I_F = 100$ mA	
200 μ m PCS Fiber Cable	P_{T200}	–10.0	–7.0	–5.0	dBm peak	$T_A = +25^\circ\text{C}, I_F = 60$ mA	
		–11.0		–4.0	dBm peak	$T_A = -40^\circ\text{C to } +85^\circ\text{C}, I_F = 60$ mA	
		–8.5	–5.0	–2.6	dBm peak	$T_A = +25^\circ\text{C}, I_F = 100$ mA	
		–10.1		–2.0	dBm peak	$T_A = -40^\circ\text{C to } +85^\circ\text{C}, I_F = 100$ mA	

CAUTION: The small junction sizes inherent to the design of these components increase the components' susceptibility to damage from electrostatic discharge (ESD). It is advised that normal static precautions be taken in handling and assembly of these components to prevent damage and/or degradation which may be induced by ESD.

HFBR-14x4Z Output Power Measured out of 1 Meter of Cable

Parameter	Symbol	Min.	Typ. [2]	Max.	Unit	Conditions	Reference
50/125 μm Fiber Cable NA = 0.2	P_{T50}	-18.8	-15.8	-13.8	dBm peak	$T_A = +25^\circ\text{C}$, $I_F = 60\text{ mA}$	Notes 5, 6, 9 Figure 10
		-19.8		-12.8	dBm peak	$T_A = -40^\circ\text{C}$ to $+85^\circ\text{C}$, $I_F = 60\text{ mA}$	
		-17.3	-13.8	-11.4	dBm peak	$T_A = +25^\circ\text{C}$, $I_F = 100\text{ mA}$	
		-18.9		-10.8	dBm peak	$T_A = -40^\circ\text{C}$ to $+85^\circ\text{C}$, $I_F = 100\text{ mA}$	
62.5/125 μm Fiber Cable NA = 0.275	P_{T62}	-15.0	-12.0	-10.0	dBm peak	$T_A = +25^\circ\text{C}$, $I_F = 60\text{ mA}$	
		-16.0		-9.0	dBm peak	$T_A = -40^\circ\text{C}$ to $+85^\circ\text{C}$, $I_F = 60\text{ mA}$	
		-13.5	-10.0	-7.6	dBm peak	$T_A = +25^\circ\text{C}$, $I_F = 100\text{ mA}$	
		-15.1		-7.0	dBm peak	$T_A = -40^\circ\text{C}$ to $+85^\circ\text{C}$, $I_F = 100\text{ mA}$	
100/140 μm Fiber Cable NA = 0.3	P_{T100}	-11.5	-8.5	-6.5	dBm peak	$T_A = +25^\circ\text{C}$, $I_F = 60\text{ mA}$	
		-12.5		-5.5	dBm peak	$T_A = -40^\circ\text{C}$ to $+85^\circ\text{C}$, $I_F = 60\text{ mA}$	
		-10.0	-6.5	-4.1	dBm peak	$T_A = +25^\circ\text{C}$, $I_F = 100\text{ mA}$	
		-11.6		-3.5	dBm peak	$T_A = -40^\circ\text{C}$ to $+85^\circ\text{C}$, $I_F = 100\text{ mA}$	
200 μm PCS Fiber Cable NA = 0.37	P_{T200}	-7.5	-4.5	-2.5	dBm peak	$T_A = +25^\circ\text{C}$, $I_F = 60\text{ mA}$	
		-8.5		-1.5	dBm peak	$T_A = -40^\circ\text{C}$ to $+85^\circ\text{C}$, $I_F = 60\text{ mA}$	
		-6.0	-2.5	-0.1	dBm peak	$T_A = +25^\circ\text{C}$, $I_F = 100\text{ mA}$	
		-7.6		0.5	dBm peak	$T_A = -40^\circ\text{C}$ to $+85^\circ\text{C}$, $I_F = 100\text{ mA}$	

HFBR-14x5Z Output Power Measured out of 1 Meter of Cable

Parameter	Symbol	Min.	Typ.	Max.	Unit	Conditions	Reference
50/125 μm Fiber Cable NA = 0.2	P_{T50}	-16.5	-14.3	-11.5	dBm peak	$T_A = +25^\circ\text{C}$, $I_F = 60\text{ mA}$	Notes 5, 6, 9
		-17.5		-10.5	dBm peak	$T_A = -40^\circ\text{C}$ to 85°C , $I_F = 60\text{ mA}$	
62.5/125 μm Fiber Cable NA = 0.275	P_{T62}	-12.0	-10.5	-8.0	dBm peak	$T_A = +25^\circ\text{C}$, $I_F = 60\text{ mA}$	Figure 10
		-13.0		-7.0	dBm peak	$T_A = -40^\circ\text{C}$ to 85°C , $I_F = 60\text{ mA}$	
200 μm Fiber Cable NA = 0.37	P_{T200}	-6.0	-3.6	0.0	dBm peak	$T_A = +25^\circ\text{C}$, $I_F = 60\text{ mA}$	
		-7.0		1.0	dBm peak	$T_A = -40^\circ\text{C}$ to 85°C , $I_F = 60\text{ mA}$	

14x2Z/14x4Z/14x5Z Dynamic Characteristics

Parameter	Symbol	Min.	Typ. [2]	Max.	Unit	Conditions	Reference
Rise Time, Fall Time (10% to 90%)	t_r , t_f		4.0	6.5	ns No pre-bias	$I_F = 60\text{ mA}$ Figure 11	Note 7
Rise Time, Fall Time (10% to 90%)	t_r , t_f		3.0		ns	$I_F = 10$ to 100 mA	Figure 12
Pulse Width Distortion	PWD		0.5		ns		Figure 12

Notes:

- For $I_{FPK} > 100\text{ mA}$, the time duration should not exceed 2 ns.
- Typical data at $T_A = +25^\circ\text{C}$.
- Thermal resistance is measured with the transmitter coupled to a connector assembly and mounted on a printed circuit board.
- D is measured at the plane of the fiber face and defines a diameter where the optical power density is within 10 dB of the maximum.
- P_T is measured with a large area detector at the end of 1 meter of mode stripped cable, with an ST precision ceramic ferrule (MILSTD- 83522/13) for HFBR-141xZ, and with an SMA 905 precision ceramic ferrule for HFBR-140xZ.
- When changing mW to dBm, the optical power is referenced to 1 mW. Optical Power P(dBm) = $10\log(P(\text{mW}) / 1\text{ mW})$
- Pre-bias is recommended if signal rate $> 10\text{ MBaud}$, see recommended drive circuit in Figure 11.
- Pins 2, 6, and 7 are welded to the anode header connection to minimize the thermal resistance from junction to ambient. To further reduce the thermal resistance, the anode trace should be made as large as is consistent with good RF circuit design.
- Fiber NA is measured at the end of 2 meters of mode stripped fiber, using the far-field pattern. NA is defined as the sine of the half angle, determined at 5% of the peak intensity point. When using other manufacturer's fiber cable, results will vary due to differing NA values and specification methods.
- Only valid for HFBR-141xPxZ (Protection improved option).

All HFBR-14XXZ LED transmitters are classified as IEC 825-1 Accessible Emission Limit (AEL) Class 1 based upon the current proposed draft scheduled to go in to effect on January 1, 1997. AEL Class 1 LED devices are considered eye safe. Contact your Broadcom Ltd. sales representative for more information.

CAUTION: The small junction sizes inherent to the design of these components increase the components' susceptibility to damage from electrostatic discharge (ESD). It is advised that normal static precautions be taken in handling and assembly of these components to prevent damage and/or degradation which may be induced by ESD.

Figure 9: Typical Forward Voltage and Current Characteristics

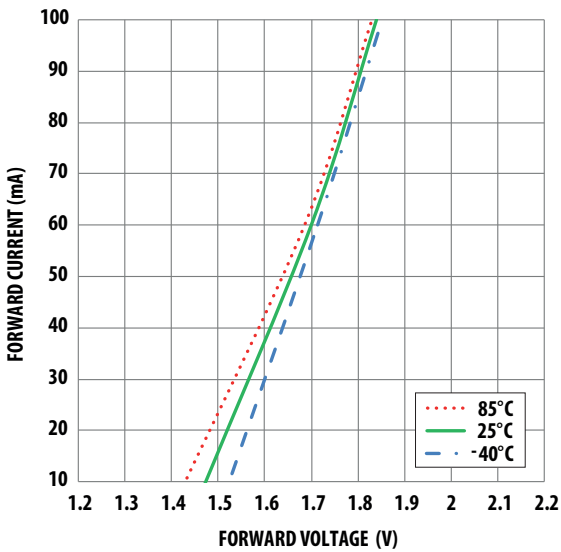
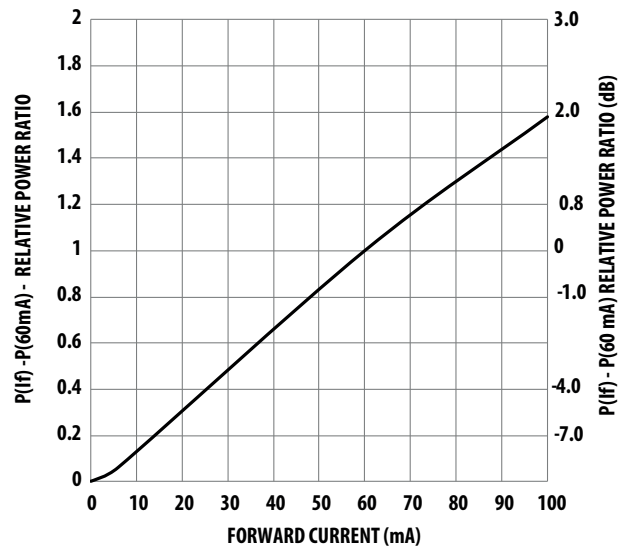

Figure 10: Normalized Typical Transmitter Output vs. Forward Current



Recommended Transmitter Driver Circuitry

Transmitter	R1	R2	R3	C3
HFBR-14x2Z/x4Z/x5Z	33Ω	33Ω	270Ω	75 pF

Figure 11: Recommended Drive Circuit

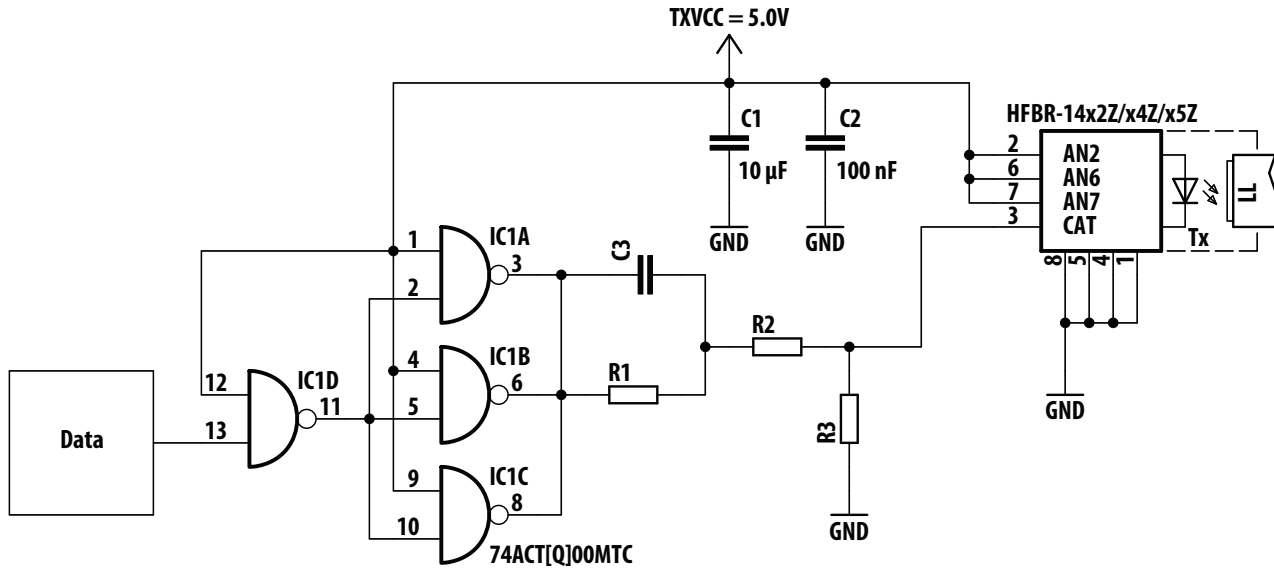

Note: The component values shown in the table create a typical driver current of 60mA (peak). An individual check of the optical output signal quality of the used optic transmitter is recommended during the circuit design.

Figure 12: Test Circuit for Measuring t_r , t_f

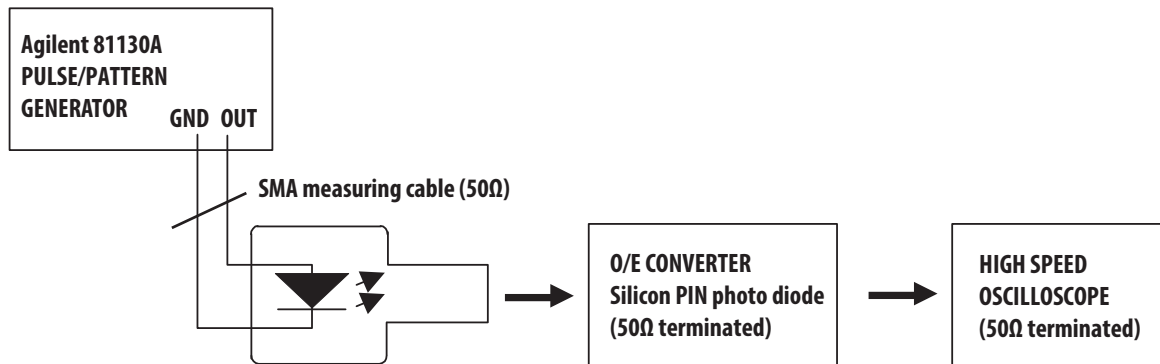

HFBR-24x2Z Low-Cost 5 MBaud Receiver

Description

The HFBR-24x2Z fiber optic receiver is designed to operate with the Broadcom Ltd. HFBR-14xxZ fiber optic transmitter and 50/125 μm , 62.5/125 μm , 100/140 μm , and 200 μm Plastic-Clad Silica (PCS) fiber optic cable. Consistent coupling into the receiver is assured by the lensed optical system (Figure 1). Response does not vary with fiber size $\leq 0.100 \mu\text{m}$.

The HFBR-24x2Z receiver incorporates an integrated photo IC containing a photodetector and dc amplifier driving an open-collector Schottky output transistor. The HFBR-24x2Z is designed for direct interfacing to popular logic families. The absence of an internal pull-up resistor allows the open-collector output to be used with logic families such as CMOS requiring voltage excursions much higher than V_{CC} .

Both the open-collector Data output Pin 6 and V_{CC} Pin 2 are referenced to Com Pins 3 and 7. The Data output allows busing, strobing and wired OR circuit configurations. The transmitter is designed to operate from a single +5V supply. It is essential that a bypass capacitor (100 nF ceramic) be connected from Pin 2 (V_{CC}) to Pin 3 (circuit common) of the receiver.

Housed Product

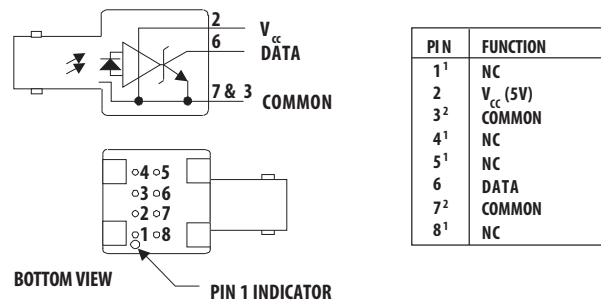

NOTES:

1. PINS 1, 4, 5, AND 8 ARE ELECTRICALLY CONNECTED.
2. PINS 3 AND 7 ARE ELECTRICALLY CONNECTED TO THE HEADER.

Absolute Maximum Ratings

Parameter	Symbol	Min.	Max.	Unit	Reference
Storage Temperature	T_S	-55	+85	$^{\circ}\text{C}$	
Operating Temperature	T_A	-40	+85	$^{\circ}\text{C}$	
Lead Soldering Cycle Temp Time			+260 10	$^{\circ}\text{C}$ sec	Note 1
Supply Voltage	V_{CC}	-0.5	+7.0	V	
Output Current	I_O		25	mA	
Output Voltage	V_O	-0.5	+18.0	V	
Output Collector Power Dissipation	P_{OAV}		40	mW	
Fan Out (TTL)	N		5		Note 2

Notes:

1. 2.0 mm from where leads enter case.
2. 8 mA load (5 x 1.6 mA), $R_L = 560\Omega$.

Electrical/Optical Characteristics

–40°C to +85°C unless otherwise specified. Fiber sizes with core diameter $\leq 100 \mu\text{m}$ and $N/A \leq 0.35$, $4.75\text{V} \leq V_{\text{CC}} \leq 5.25\text{V}$.

Parameter	Symbol	Min.	Typ. [3]	Max.	Unit	Conditions	Reference
High Level Output Current	I_{OH}		5	250	μA	$V_{\text{O}} = 18$, $P_{\text{R}} < -40 \text{ dBm}$	
Low Level Output Voltage	V_{OL}		0.4	0.5	V	$I_{\text{O}} = 8 \text{ m}$, $P_{\text{R}} > -24 \text{ dBm}$	
High Level Supply Current	I_{CCH}		3.5	6.3	mA	$V_{\text{CC}} = 5.25 \text{ V}$, $P_{\text{R}} < -40 \text{ dBm}$	
Low Level Supply Current	I_{CCL}		6.2	10	mA	$V_{\text{CC}} = 5.25 \text{ V}$, $P_{\text{R}} > -24 \text{ dBm}$	
Equivalent NA	NA		0.50				
Optical Port Diameter	D		400		μm		Note 4

Dynamic Characteristics

–40°C to +85°C unless otherwise specified; $4.75\text{V} \leq V_{\text{CC}} \leq 5.25\text{V}$; $\text{BER} \leq 10^{-9}$

Parameter	Symbol	Min.	Typ. [3]	Max.	Unit	Conditions	Reference
Peak Optical Input Power Logic Level HIGH	P_{RH}			–40 0.1	dBm peak μW peak	$\lambda_{\text{p}} = 820 \text{ nm}$	Note 5
Peak Optical Input Power Logic Level LOW	P_{RL}	–25.4 2.9		–9.2 120	dBm peak μW peak	$T_{\text{A}} = +25^{\circ}\text{C}$, $I_{\text{OL}} = 8 \text{ mA}$	Note 5
		–24.0 4.0		–10.0 100	dBm peak μW peak	$T_{\text{A}} = -40^{\circ}\text{C}$ to $+85^{\circ}\text{C}$, $I_{\text{OL}} = 8 \text{ mA}$	
Propagation Delay LOW to HIGH	t_{PLHR}		65		ns	$T_{\text{A}} = +25^{\circ}\text{C}$, $P_{\text{R}} = -21 \text{ dBm}$, Data Rate = 5 MBaud	Note 6
Propagation Delay HIGH to LOW	t_{PHLR}		49		ns		

- Notes:**
- 2.0 mm from where leads enter case.
 - 8 mA load ($5 \times 1.6 \text{ mA}$), $R_{\text{L}} = 560\Omega$.
 - Typical data at $T_{\text{A}} = +25^{\circ}\text{C}$, $V_{\text{CC}} = 5.0V_{\text{DC}}$.
 - D is the effective diameter of the detector image on the plane of the fiber face. The numerical value is the product of the actual detector diameter and the lens magnification.
 - Measured at the end of 100/140 μm fiber optic cable with large area detector.
 - Propagation delay through the system is the result of several sequentially-occurring phenomena. Consequently it is a combination of data-rate-limiting effects and of transmission-time effects. Because of this, the data-rate limit of the system must be described in terms of time differentials between delays imposed on falling and rising edges. As the cable length is increased, the propagation delays increase at 5 ns per meter of length. Data rate, as limited by pulse width distortion, is not affected by increasing cable length if the optical power level at the receiver is maintained.

CAUTION: The small junction sizes inherent to the design of these components increase the components' susceptibility to damage from electrostatic discharge (ESD). It is advised that normal static precautions be taken in handling and assembly of these components to prevent damage and/or degradation which may be induced by ESD.

HFBR-24x6Z Low-Cost 125 MHz Receiver

Description

The HFBR-24x6Z fiber optic receiver is designed to operate with the Broadcom Ltd. HFBR-14xxZ fiber optic transmitters and 50/125 μm , 62.5/125 μm , 100/140 μm , and 200 μm Plastic-Clad Silica (PCS) fiber optic cable. Consistent coupling into the receiver is assured by the lensed optical system (Figure 1). Response does not vary with fiber size for core diameters of 100 μm or less.

The receiver output is an analog signal which allows follow-on circuitry to be optimized for a variety of distance/data rate requirements. Low-cost external components can be used to convert the analog output to logic compatible signal levels for various data formats and data rates up to 175 MBaud. This distance/data rate trade-off results in increased optical power budget at lower data rates which can be used for additional distance or splices.

The HFBR-24x6Z receiver contains a PIN photodiode and low noise transimpedance preamplifier integrated circuit. The HFBR-24x6Z receives an optical signal and converts it to an analog voltage. The output is a buffered emitter follower. Because the signal amplitude from the HFBR-24x6Z receiver is much larger than from a simple PIN photodiode, it is less susceptible to EMI, especially at high signaling rates. For very noisy environments, the conductive or metal port option is recommended. A receiver dynamic range of 23 dB over temperature is achievable, assuming a Bit Error Rate (BER) of 10^{-9} .

The frequency response is typically DC to 125 MHz. Although the HFBR-24x6Z is an analog receiver, it is compatible with digital systems.

The recommended ac coupled receiver circuit is shown in Figure 14. A 10Ω resistor must be connected between pin 6 and the power supply, and a 100 nF ceramic bypass capacitor must be connected between the power supply and ground. In addition, pin 6 should be filtered to protect the receiver from noisy host systems. Refer to AN 1065 for details.

Figure 13: Simplified Schematic Diagram



Housed Product



PIN	FUNCTION
1 ¹	NC
2	SIGNAL
3 ²	V _{EE}
4 ¹	NC
5 ¹	NC
6	V _{CC}
7 ²	V _{EE}
8 ¹	NC

NOTES:

1. PINS 1, 4, 5, AND 8 ARE ISOLATED FROM THE INTERNAL CIRCUITRY, BUT ARE CONNECTED TO EACH OTHER.
2. PINS 3 AND 7 ARE ELECTRICALLY CONNECTED TO THE HEADER.

CAUTION: The small junction sizes inherent to the design of these components increase the components' susceptibility to damage from electrostatic discharge (ESD). It is advised that normal static precautions be taken in handling and assembly of these components to prevent damage and/or degradation which may be induced by ESD.

Absolute Maximum Ratings

Parameter	Symbol	Min.	Max.	Unit	Reference
Storage Temperature	T_S	-55	+85	°C	
Operating Temperature	T_A	-40	+85	°C	
Lead Soldering Cycle Temp Time			+260 10	°C sec	Note 1
Supply Voltage	V_{CC}	-0.5	+6.0	V	
Output Current	I_O		25	mA	
Signal Pin Voltage	V_{SIG}	-0.5	V_{CC}	V	

Electrical/Optical Characteristics

-40°C to +85°C; 4.75V ≤ Supply Voltage ≤ 5.25 V, $R_{LOAD} = 511\Omega$, Fiber sizes with core diameter ≤ 100 μm, and NA ≤ 0.35 unless otherwise specified.

Parameter	Symbol	Min.	Typ. [2]	Max.	Unit	Conditions	Reference
Responsivity	R_p	5.3	7	9.6	mV/μW	$T_A = +25^\circ\text{C}$ at 820 nm, 50 MHz	Note 3, 4 Figure 18
		4.5		11.5	mV/μW	$T_A = -40^\circ\text{C}$ to $+85^\circ\text{C}$ at 820nm, 50MHz	
RMS Output Noise Voltage	V_{NO}		0.40	0.59	mV	Bandwidth filtered at 75 MHz $P_R = 0 \mu\text{W}$	Note 5 Figure 15
				0.70	mV	Unfiltered bandwidth $P_R = 0 \mu\text{W}$	
Equivalent Input Optical Noise Power (RMS)	PN		-43.0 0.050	-41.4 0.065	dBm μW	Bandwidth filtered at 75 MHz	
Optical Input Power (Overdrive)	P_R			-7.6 175	dBm peak μW peak	$T_A = +25^\circ\text{C}$	Note 6 Figure 16
				-8.2 150	dBm peak μW peak	$T_A = -40^\circ\text{C}$ to $+85^\circ\text{C}$	
Output Impedance	Z_O		30		Ω	Test Frequency = 50 MHz	
dc Output Voltage	$V_{O\text{dc}}$	$V_{CC} - 4.2$	$V_{CC} - 3.1$	$V_{CC} - 2.4$	V	$P_R = 0 \mu\text{W}$	
Power Supply Current	I_{EE}		9	15	mA	$R_{LOAD} = 510\Omega$	
Equivalent NA	NA		0.35				
Equivalent Diameter	D		324		μm		Note 7

CAUTION: The small junction sizes inherent to the design of these components increase the components' susceptibility to damage from electrostatic discharge (ESD). It is advised that normal static precautions be taken in handling and assembly of these components to prevent damage and/or degradation which may be induced by ESD.

Dynamic Characteristics

-40°C to +85°C; 4.75V ≤ Supply Voltage ≤ 5.25V; R_{LOAD} = 511Ω, C_{LOAD} = 5 pF unless otherwise specified

Parameter	Symbol	Min.	Typ. [2]	Max.	Unit	Conditions	Reference
Rise/Fall Time 10% to 90%	t _r , t _f		3.3	6.3	ns	P _R = 100 μW peak	Figure 17
Pulse Width Distortion	PWD		0.4	2.5	ns	P _R = 150 μW peak	Note 8, Figure 16
Overshoot			2		%	P _R = 5 μW peak, t _r = 1.5 ns	Note 9
Bandwidth (Electrical)	BW		125		MHz	-3 dB Electrical	
Bandwidth - Rise Time Product			0.41		Hz × s	Note 10	

- Notes:**
- 2.0 mm from where leads enter case.
 - Typical specifications are for operation at T_A = +25°C and V_{CC} = +5V DC.
 - For 200 μm PCS fibers, typical responsivity will be 6 mV/mW. Other parameters will change as well.
 - Pin #2 should be ac coupled to a load 510Ω. Load capacitance must be less than 5 pF.
 - Measured with a 3 pole Bessel filter with a 75 MHz, -3 dB bandwidth.
 - Overdrive is defined at PWD = 2.5 ns.
 - D is the effective diameter of the detector image on the plane of the fiber face. The numerical value is the product of the actual detector diameter and the lens magnification.
 - Measured with a 10 ns pulse width, 50% duty cycle, at the 50% amplitude point of the waveform.
 - Percent overshoot is defined as:

$$\left(\frac{V_{PK} - V_{100\%}}{V_{100\%}} \right) \times 100\%$$

- The conversion factor for the rise time to bandwidth is 0.41 since the HFBR-24x6Z has a second order bandwidth limiting characteristic.

Figure 14: Recommended AC-Coupled Receiver Circuit



CAUTION: The small junction sizes inherent to the design of these components increase the components' susceptibility to damage from electrostatic discharge (ESD). It is advised that normal static precautions be taken in handling and assembly of these components to prevent damage and/or degradation which may be induced by ESD.

Figure 15: Typical Spectral Noise Density vs. Frequency

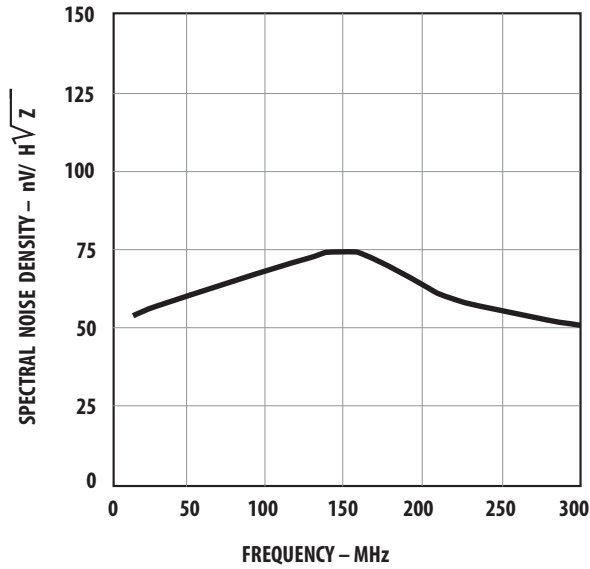

Figure 16: Typical Pulse Width Distortion vs. Peak Input Power

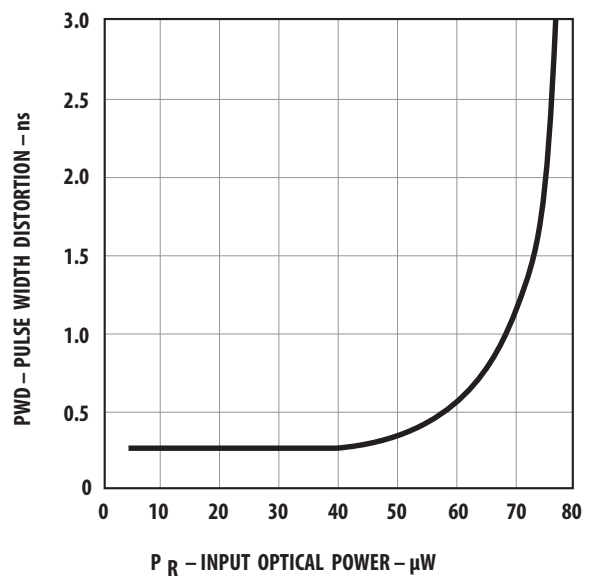

Figure 17: Typical Rise and Fall Times vs. Temperature

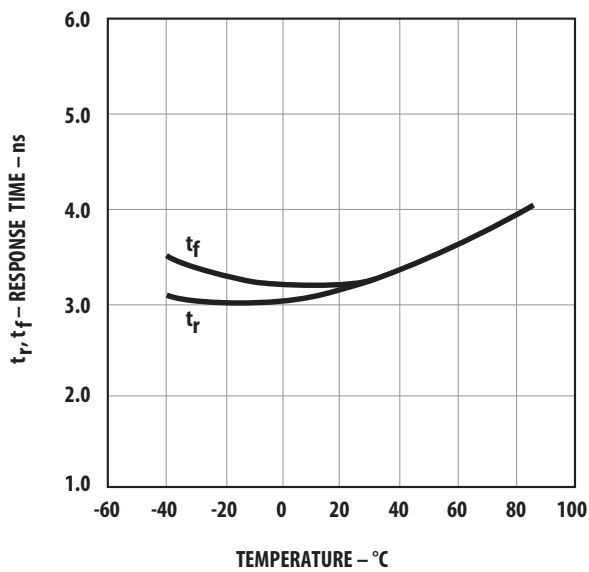
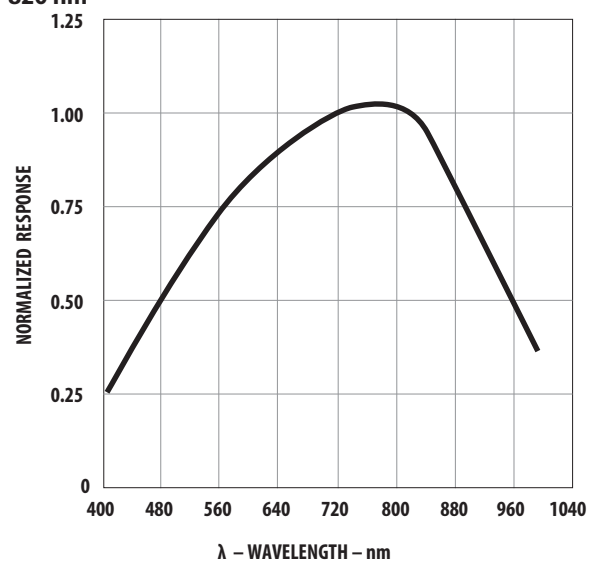

Figure 18: Typical Receiver Spectral Response Normalized to 820 nm



For product information and a complete list of distributors, please go to our web site:
www.broadcom.com.



Broadcom, the pulse logo, Connecting everything, Avago Technologies, Avago, the A logo, and R²Coupler are among the trademarks of Broadcom and/or its affiliates in the United States, certain other countries and/or the EU.

Broadcom Proprietary and Confidential. Copyright © 2017-2018 Broadcom. All Rights Reserved. The term "Broadcom" refers to Broadcom Limited and/or its subsidiaries.

Broadcom reserves the right to make changes without further notice to any products or data herein to improve reliability, function, or design. Information furnished by Broadcom is believed to be accurate and reliable. However, Broadcom does not assume any liability arising out of the application or use of this information, nor the application or use of any product or circuit described herein, neither does it convey any license under its patent rights nor the rights of others.

AV02-0176EN – March 13, 2018

Компания «Океан Электроники» предлагает заключение долгосрочных отношений при поставках импортных электронных компонентов на взаимовыгодных условиях!

Наши преимущества:

- Поставка оригинальных импортных электронных компонентов напрямую с производств Америки, Европы и Азии, а так же с крупнейших складов мира;
- Широкая линейка поставок активных и пассивных импортных электронных компонентов (более 30 млн. наименований);
- Поставка сложных, дефицитных, либо снятых с производства позиций;
- Оперативные сроки поставки под заказ (от 5 рабочих дней);
- Экспресс доставка в любую точку России;
- Помощь Конструкторского Отдела и консультации квалифицированных инженеров;
- Техническая поддержка проекта, помощь в подборе аналогов, поставка прототипов;
- Поставка электронных компонентов под контролем ВП;
- Система менеджмента качества сертифицирована по Международному стандарту ISO 9001;
- При необходимости вся продукция военного и аэрокосмического назначения проходит испытания и сертификацию в лаборатории (по согласованию с заказчиком);
- Поставка специализированных компонентов военного и аэрокосмического уровня качества (Xilinx, Altera, Analog Devices, Intersil, Interpoint, Microsemi, Actel, Aeroflex, Peregrine, VPT, Syfer, Eurofarad, Texas Instruments, MS Kennedy, Miteq, Cobham, E2V, MA-COM, Hittite, Mini-Circuits, General Dynamics и др.);

Компания «Океан Электроники» является официальным дистрибьютором и эксклюзивным представителем в России одного из крупнейших производителей разъемов военного и аэрокосмического назначения «JONHON», а так же официальным дистрибьютором и эксклюзивным представителем в России производителя высокотехнологичных и надежных решений для передачи СВЧ сигналов «FORSTAR».



JONHON

«JONHON» (основан в 1970 г.)

Разъемы специального, военного и аэрокосмического назначения:

(Применяются в военной, авиационной, аэрокосмической, морской, железнодорожной, горно- и нефтедобывающей отраслях промышленности)

«FORSTAR» (основан в 1998 г.)

ВЧ соединители, коаксиальные кабели,
кабельные сборки и микроволновые компоненты:

(Применяются в телекоммуникациях гражданского и специального назначения, в средствах связи, РЛС, а так же военной, авиационной и аэрокосмической отраслях промышленности).



Телефон: 8 (812) 309-75-97 (многоканальный)

Факс: 8 (812) 320-03-32

Электронная почта: ocean@oceanchips.ru

Web: <http://oceanchips.ru/>

Адрес: 198099, г. Санкт-Петербург, ул. Калинина, д. 2, корп. 4, лит. А