

NCV8871SEPGVB

NCV8871 Automotive Grade High-Frequency SEPIC Controller Evaluation Board User's Manual



ON Semiconductor®

<http://onsemi.com>

EVAL BOARD USER'S MANUAL

Description

This NCV8871 evaluation board provides a convenient way to evaluate a high-frequency current-mode control SEPIC converter design. The topology uses two inductors. No additional components are required, other than dc supplies for the input and enable voltages. An external clock can be used to synchronize the switching frequency. The output is rated 12 V / 2 A with a 170 KHz switching frequency over the typical 6 V to 18 V automotive input voltage range.

Key Features

- 12 V / 2 A Output
- 170 KHz Switching Frequency (NCV887100)
- Input Undervoltage Lockout
- Internal Soft-Start
- Wide Input Voltage of 6 V to 40 V
- Regulates through 45 V Load Dump Conditions
- External Clock Synchronization up to 1.1 MHz
- Automotive Grade

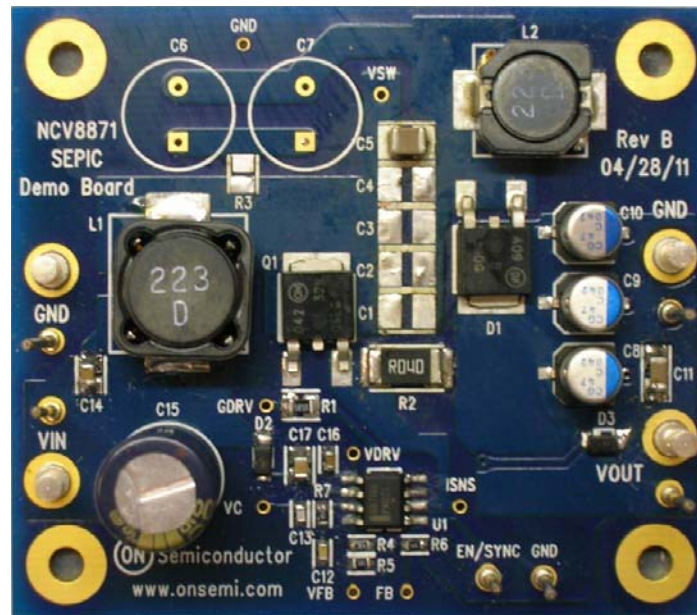

Figure 1. NCV887100 SEPIC Evaluation Board

NCV8871SEPGVB

Table 1. EVALUATION BOARD TERMINALS

Terminal	Function
VIN	Positive DC input voltage.
GND	Common DC return.
VOUT	Regulated DC output voltage.
EN/SYNC	Enable and synchronization input.

Table 2. ABSOLUTE MAXIMUM RATINGS (Voltages are with respect to GND)

Rating	Value	Unit
DC Supply Voltage (VIN)	-0.3 to 40	V
DC Supply Voltage (EN/SYNC)	-0.3 to 6	V
Peak Transient Voltage (Load Dump on VIN)	45	V
Junction Temperature	-40 to 150	°C
Ambient Temperature (evaluation board)	-40 to 105	°C

Stresses exceeding Maximum Ratings may damage the device. Maximum Ratings are stress ratings only. Functional operation above the Recommended Operating Conditions is not implied. Extended exposure to stresses above the Recommended Operating Conditions may affect device reliability.

Table 3. ELECTRICAL CHARACTERISTICS

($T_A = 25^\circ\text{C}$, $4.5\text{ V} \leq V_{IN} \leq 40\text{ V}$, $V_{EN} = 2\text{ V}$, $V_{OUT} = 3.3\text{ V}$, $0 \leq I_{OUT} \leq 1.2\text{ A}$, unless otherwise specified)

Characteristic	Conditions	Typical Value	Unit
Switching			
Switching Frequency		170	KHz
Soft-start Time		7.4	ms
SYNC Frequency Range		170 – 1025	KHz
Current Limit			
Cycle-by-cycle Current Limit (FET)		10	A
Protections			
Input Undervoltage Lockout (UVLO)	V_{IN} decreasing	< 6*	V
Input Undervoltage Lockout (UVLO)	V_{IN} increasing	6.7	V
Thermal Shutdown	T_A increasing	170	°C

*See Note 3 from Operational Guidelines (on next page)

NCV8871SEPGVB

OPERATIONAL GUIDELINES

1. Connect a DC input voltage, within the 6 V to 40 V range, between V_{IN} and GND.
2. Connect a DC enable voltage, within the 2.0 V to 5.0 V range, between EN/SYNC and GND.
3. The evaluation board feedback components were selected to for continuous operation at rated 12 V / 2 A output power at a minimum input voltage of 6 V. The NCV887100 V_{IN} has its operational voltage diode-ored between the converter output (12 V) and input voltages. The converter turns-on typically at 6.7 V. Once energized, the output voltage supplies power to the IC when the battery voltage is below (approximately) 11.5 V. The decreasing V_{IN} UVLO voltage depends on load current as well as

V_{IN} , and will be less than 6 V when operating below rated output current.

4. Optionally for external clock synchronization, connect a pulse source between EN/SYNC and GND. The high state level should be within the 2 to 5 V range, and the low state level within the -0.3 V to 0.8 V range, with a minimum pulse width of 40 ns and a frequency within the 170 and 1100 KHz range.

NOTE: The converter was designed for 170 KHz 12 V / 2 A continuous mode operation. Operation beyond 170 KHz and/or at a different output voltage may require modifications of feedback loop component and inductor values.

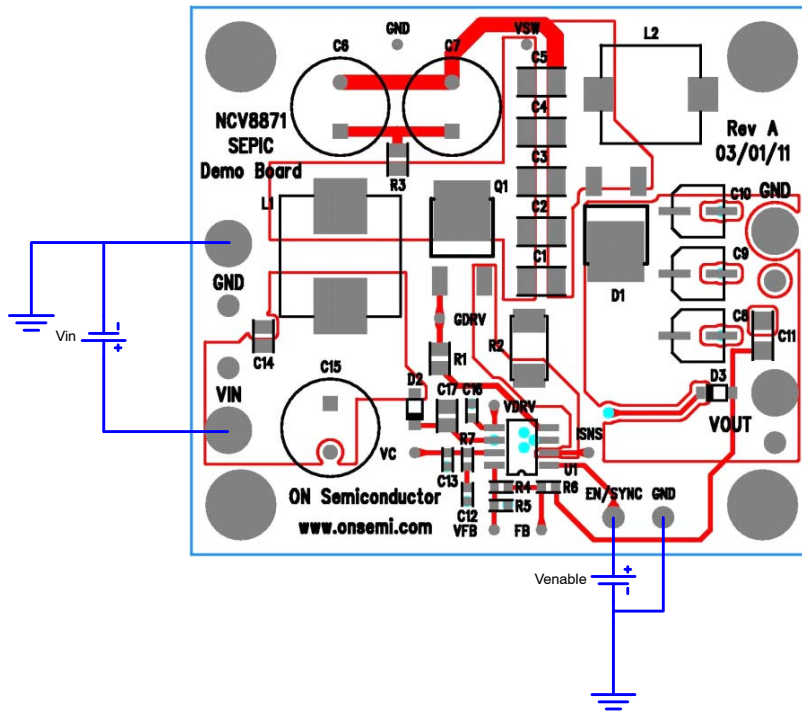

Figure 2. Evaluation Board Connections

NCV8871SEPGVB

TYPICAL PERFORMANCE

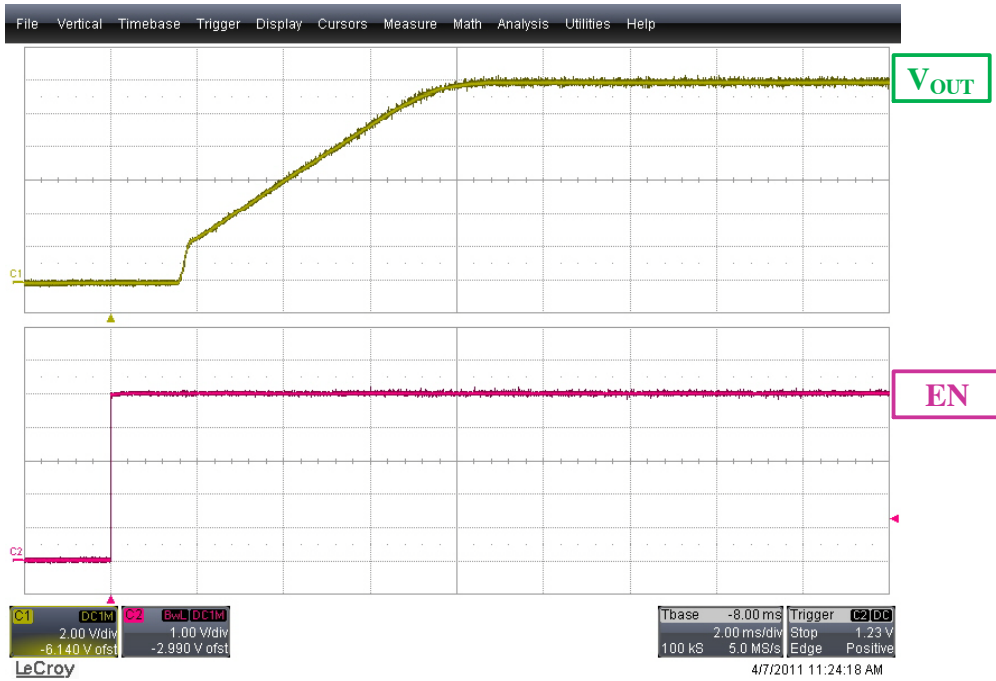

Figure 3. Typical Start-up with $V_{IN} = 12\text{ V}$, $R_{OUT} = 6\ \Omega$

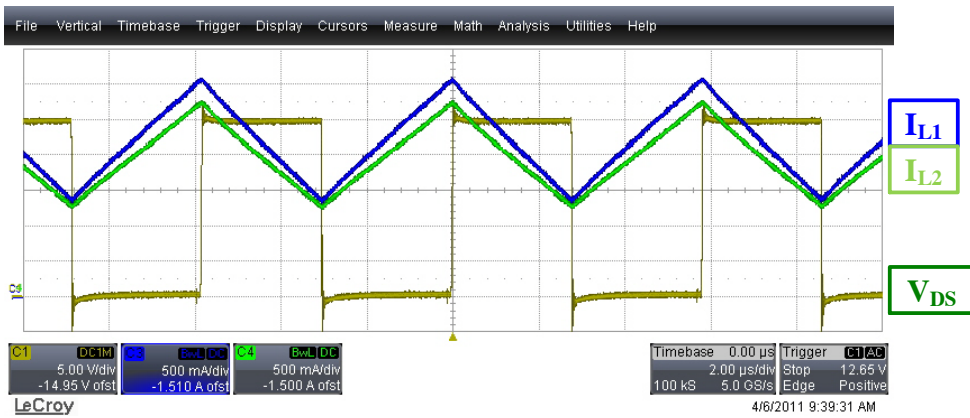

Figure 4. Operational Waveforms, $V_{IN} = 12\text{ V}$, $R_{OUT} = 6\ \Omega$

NCV8871SEPGEVB

SCHEMATIC

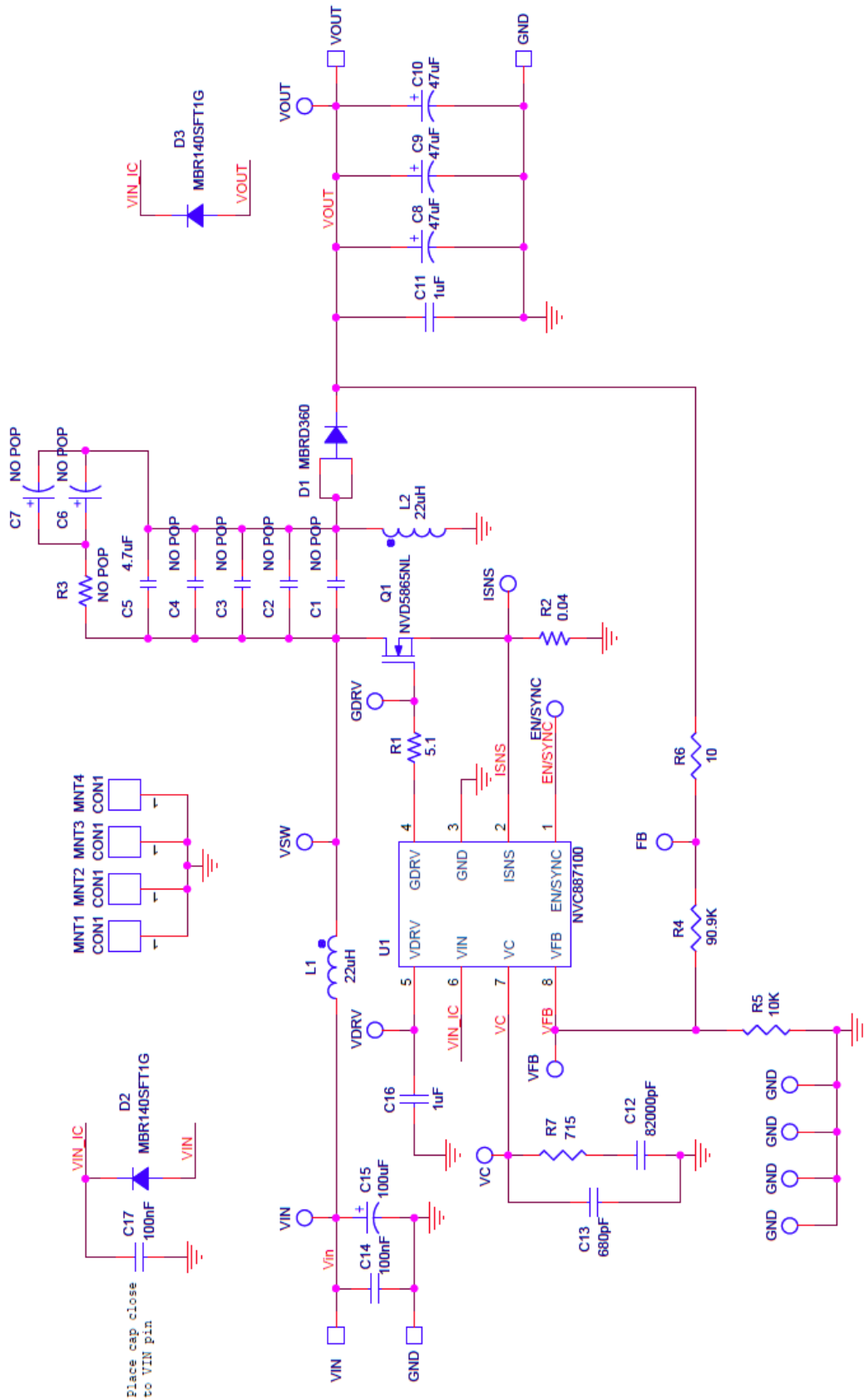

Figure 5. NCV887100 SEPIC Evaluation Board Schematic

NCV8871SEPGVB

Table 4. BILL OF MATERIALS

Component	Description	Manufacturer P/N	Vendor P/N
C1	DO NOT POPULATE		
C2	DO NOT POPULATE		
C3	DO NOT POPULATE		
C4	DO NOT POPULATE		
C5	CAP CER 4.7UF 50V 10% X7R 1210	GRM32ER71H475KA88L	490-1864-1-ND
C6	DO NOT POPULATE		
C7	DO NOT POPULATE		
C8	CAP POLY ALUM 47UF 16V SMD	PCG1C470MCL1GS	493-3095-1-ND
C9	CAP POLY ALUM 47UF 16V SMD	PCG1C470MCL1GS	493-3095-1-ND
C10	CAP POLY ALUM 47UF 16V SMD	PCG1C470MCL1GS	493-3095-1-ND
C11	CAP CER 1UF 50V X7R 1206	GCM31MR71H105KA55L	490-4795-1-ND
C12	CAP CER .082UF 10% 16V X7R 0603	0603YC823KAT2A	478-1238-1-ND
C13	CAP CER 680PF 50V 5% C0G 0603	GRM1885C1H681JA01D	490-1447-1-ND
C14	CAP CER .1UF 50V X7R 0603	GCM188R71H104KA57D	490-4779-1-ND
C15	CAP 100UF 50V ELECT FC RADIAL	EEU-FC1H101	P10323-ND
C16	CAP CER 1UF 16V X7R 10% 0603	GCM188R71C105KA64D	490-5241-1-ND
C17	CAP CER .1UF 50V X7R 0603	GCM188R71H104KA57D	490-4779-1-ND
D1	60 V, 3.0 A Schottky Rectifier DPAK	MBRD360G	MBRD360G
D2	DIODE SCHOTTKY 40V 1A SOD123FL	MBR140SFT1G	MBR140SFT1G
D3	DIODE SCHOTTKY 40V 1A SOD123FL	MBR140SFT1G	MBR140SFT1G
L1	High Temp SMT Power Inductor 2.3A	MSS1260T-223ML	MSS1260T-223ML
L2	High Temp SMT Power Inductor 1.9A	MSS1038T-223ML	MSS1038T-223ML
Q1	N-CHANNEL MOSFET, LOGIC LEVEL, 60V 16mOHMS	NVD5865NL	NVD5865NL
R1	RES 5.10 OHM 1/8W 1% 0805 SMD	CRCW08055R10FKEA	541-5.10CCCT-ND
R2	RES .04 OHM 3W 1% 2512 SMD	CRA2512-FZ-R040ELF	CRA2512-FZ-R040ELFCT-ND
R3	DO NOT POPULATE		
R4	RES 90.9K OHM 1/10W 1% 0603 SMD	RC0603FR-0790K9L	311-90.9KHRCT-ND
R5	RES 10.0K OHM 1/10W 1% 0603 SMD	MCR03EZPFX1002	RHM10.0KHCT-ND
R6	RES 10.0 OHM 1/10W 1% 0603 SMD	RC0603FR-0710RL	311-10.0HRCT-ND
R7	RES 715 OHM 1/10W 1% 0603 SMD	CRCW0603715RFKEA	541-715HCT-ND
U1	ON SEMI Non-Sync Boost Controller	NCV887100	NCV887100D1R2G

NCV8871SEPGEVB

PCB LAYOUT

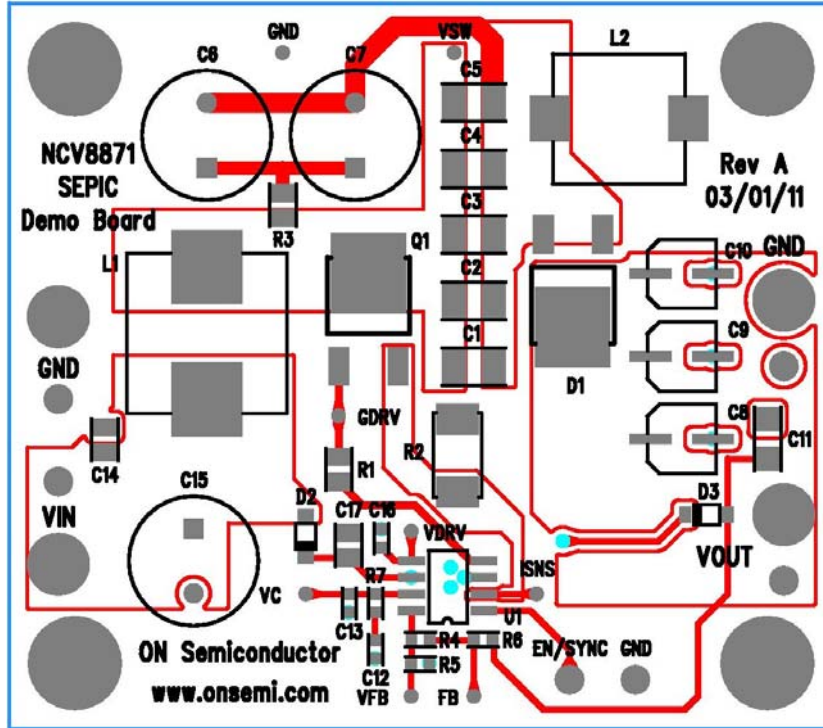

Figure 6. Top View

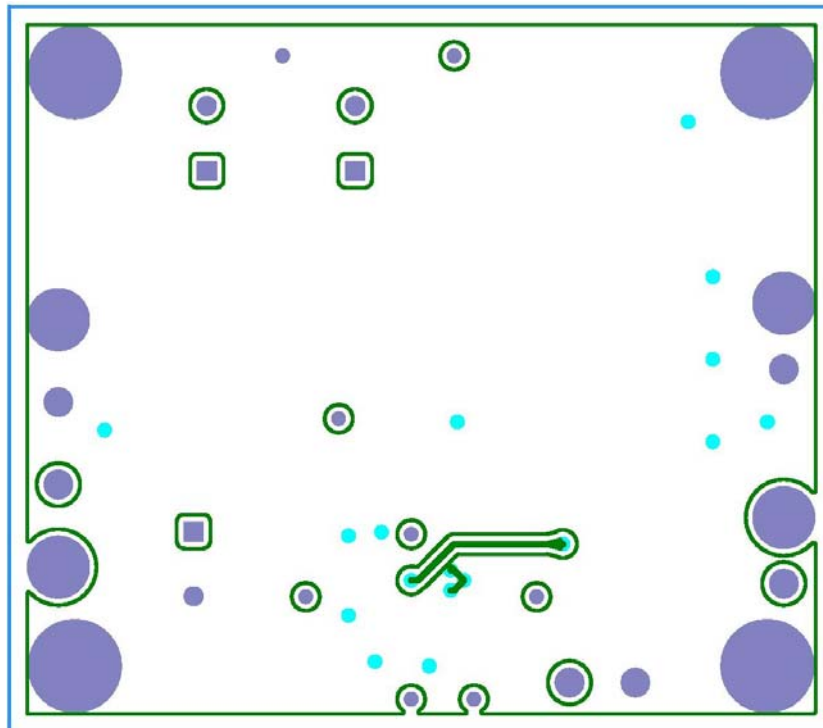



Figure 7. Bottom View

ON Semiconductor and  are registered trademarks of Semiconductor Components Industries, LLC (SCILLC). SCILLC owns the rights to a number of patents, trademarks, copyrights, trade secrets, and other intellectual property. A listing of SCILLC's product/patent coverage may be accessed at www.onsemi.com/site/pdf/Patent-Marking.pdf. SCILLC reserves the right to make changes without further notice to any products herein. SCILLC makes no warranty, representation or guarantee regarding the suitability of its products for any particular purpose, nor does SCILLC assume any liability arising out of the application or use of any product or circuit, and specifically disclaims any and all liability, including without limitation special, consequential or incidental damages. "Typical" parameters which may be provided in SCILLC data sheets and/or specifications can and do vary in different applications and actual performance may vary over time. All operating parameters, including "Typicals" must be validated for each customer application by customer's technical experts. SCILLC does not convey any license under its patent rights nor the rights of others. SCILLC products are not designed, intended, or authorized for use as components in systems intended for surgical implant into the body, or other applications intended to support or sustain life, or for any other application in which the failure of the SCILLC product could create a situation where personal injury or death may occur. Should Buyer purchase or use SCILLC products for any such unintended or unauthorized application, Buyer shall indemnify and hold SCILLC and its officers, employees, subsidiaries, affiliates, and distributors harmless against all claims, costs, damages, and expenses, and reasonable attorney fees arising out of, directly or indirectly, any claim of personal injury or death associated with such unintended or unauthorized use, even if such claim alleges that SCILLC was negligent regarding the design or manufacture of the part. SCILLC is an Equal Opportunity/Affirmative Action Employer. This literature is subject to all applicable copyright laws and is not for resale in any manner.

PUBLICATION ORDERING INFORMATION

LITERATURE FULFILLMENT:

Literature Distribution Center for ON Semiconductor
P.O. Box 5163, Denver, Colorado 80217 USA
Phone: 303-675-2175 or 800-344-3860 Toll Free USA/Canada
Fax: 303-675-2176 or 800-344-3867 Toll Free USA/Canada
Email: orderlit@onsemi.com

N. American Technical Support: 800-282-9855 Toll Free
USA/Canada
Europe, Middle East and Africa Technical Support:
Phone: 421 33 790 2910
Japan Customer Focus Center
Phone: 81-3-5817-1050

ON Semiconductor Website: www.onsemi.com
Order Literature: <http://www.onsemi.com/orderlit>
For additional information, please contact your local
Sales Representative

Компания «Океан Электроники» предлагает заключение долгосрочных отношений при поставках импортных электронных компонентов на взаимовыгодных условиях!

Наши преимущества:

- Поставка оригинальных импортных электронных компонентов напрямую с производств Америки, Европы и Азии, а так же с крупнейших складов мира;
- Широкая линейка поставок активных и пассивных импортных электронных компонентов (более 30 млн. наименований);
- Поставка сложных, дефицитных, либо снятых с производства позиций;
- Оперативные сроки поставки под заказ (от 5 рабочих дней);
- Экспресс доставка в любую точку России;
- Помощь Конструкторского Отдела и консультации квалифицированных инженеров;
- Техническая поддержка проекта, помощь в подборе аналогов, поставка прототипов;
- Поставка электронных компонентов под контролем ВП;
- Система менеджмента качества сертифицирована по Международному стандарту ISO 9001;
- При необходимости вся продукция военного и аэрокосмического назначения проходит испытания и сертификацию в лаборатории (по согласованию с заказчиком);
- Поставка специализированных компонентов военного и аэрокосмического уровня качества (Xilinx, Altera, Analog Devices, Intersil, Interpoint, Microsemi, Actel, Aeroflex, Peregrine, VPT, Syfer, Eurofarad, Texas Instruments, MS Kennedy, Miteq, Cobham, E2V, MA-COM, Hittite, Mini-Circuits, General Dynamics и др.);

Компания «Океан Электроники» является официальным дистрибьютором и эксклюзивным представителем в России одного из крупнейших производителей разъемов военного и аэрокосмического назначения «JONHON», а так же официальным дистрибьютором и эксклюзивным представителем в России производителя высокотехнологичных и надежных решений для передачи СВЧ сигналов «FORSTAR».



JONHON

«JONHON» (основан в 1970 г.)

Разъемы специального, военного и аэрокосмического назначения:

(Применяются в военной, авиационной, аэрокосмической, морской, железнодорожной, горно- и нефтедобывающей отраслях промышленности)

«FORSTAR» (основан в 1998 г.)

ВЧ соединители, коаксиальные кабели, кабельные сборки и микроволновые компоненты:

(Применяются в телекоммуникациях гражданского и специального назначения, в средствах связи, РЛС, а так же военной, авиационной и аэрокосмической отраслях промышленности).



Телефон: 8 (812) 309-75-97 (многоканальный)

Факс: 8 (812) 320-03-32

Электронная почта: ocean@oceanchips.ru

Web: <http://oceanchips.ru/>

Адрес: 198099, г. Санкт-Петербург, ул. Калинина, д. 2, корп. 4, лит. А