

# 72-Mbit QDR® II+ SRAM Four-Word Burst Architecture with RadStop™ Technology

## Radiation Performance

### Radiation Data

- Total Dose = 300 Krad
- Soft error rate (both Heavy Ion and proton)  
 Heavy ions  $\leq 1 \times 10^{-10}$  upsets/bit-day with an external SECEDED EDAC Controller
- Neutrons =  $2.0 \times 10^{14}$  N/cm<sup>2</sup>
- Dose rate =  $2.0 \times 10^9$  rad(Si)/sec
- Dose rate survivability (rad(Si)/sec) =  $1.5 \times 10^{11}$  (rad(Si)/sec)
- Latch up immunity = 120 MeV.cm<sup>2</sup>/mg (125 °C)

### Prototyping Options

- Non-qualified CYPT1543AV18, and CYPT1545AV18 devices with same functional and timing characteristics in a 165-ball Ceramic Column Grid Array (CCGA) package and Land Grid Array (LGA) package without solder columns attached.

## Features

- Separate independent read and write data ports
  - Supports concurrent transactions
- 250 MHz clock for high bandwidth
- Four-word burst for reducing address bus frequency
- Double data rate (DDR) interfaces on both read and write ports at 250 MHz (data transferred at 500 MHz)
- Two input clocks (K and  $\bar{K}$ ) for precise DDR timing
  - SRAM uses rising edges only
- Echo clocks (CQ and  $\bar{CQ}$ ) simplify data capture in high speed systems
- Single multiplexed address input bus latches address inputs for read and write ports
- Separate port selects for depth expansion
- Synchronous internally self-timed writes
- QDR® II+ operates with 2.0 cycle read latency when the delay lock loop (DLL) is enabled
- Available in  $\times 18$ , and  $\times 36$  configurations
- Full data coherency, providing most current data
- Core  $V_{DD} = 1.8 (\pm 0.1 \text{ V})$ ; I/O  $V_{DDQ} = 1.4 \text{ V}$  to  $V_{DD}$
- Available in 165-ball CCGA (21  $\times$  25  $\times$  2.83 mm)

- HSTL inputs and variable drive HSTL output buffers
- JTAG 1149.1 compatible test access port
- DLL for accurate data placement

## Configurations

CYRS1543AV18 – 4M  $\times$  18

CYRS1545AV18 – 2M  $\times$  36

## Functional Description

The CYRS1543AV18 and CYRS1545AV18 are synchronous pipelined SRAMs, equipped with 1.8 V QDR II+ architecture with RadStop™ technology. Cypress's state-of-the-art RadStop Technology is radiation hardened through proprietary design and process hardening techniques.

The QDR II+ architecture consists of two separate ports: the read port and the write port to access the memory array. The read port has dedicated data outputs to support read operations and the write port has dedicated data inputs to support write operations. QDR II+ architecture has separate data inputs and data outputs to completely eliminate the need to turnaround the data bus that exists with common I/O devices. Each port can be accessed through a common address bus. Addresses for read and write addresses are latched on alternate rising edges of the input (K) clock. Accesses to the QDR II+ read and write ports are completely independent of one another. To maximize data throughput, both read and write ports are equipped with DDR interfaces. Each address location is associated with four 18-bit words (CYRS1543AV18) or 36-bit words (CYRS1545AV18) that burst sequentially into or out of the device. Because data can be transferred into and out of the device on every rising edge of both input clocks (K and  $\bar{K}$ ), memory bandwidth is maximized while simplifying system design by eliminating bus turnarounds.

Depth expansion is accomplished with port selects, which enables each port to operate independently.

All synchronous inputs pass through input registers controlled by the K or  $\bar{K}$  input clocks. All data outputs pass through output registers controlled by the K or  $\bar{K}$  input clocks. Writes are conducted with on-chip synchronous self-timed write circuitry.

For a complete list of related resources, [click here](#).

## Selection Guide

Description	250 MHz	Unit
Maximum operating frequency	250	MHz
Maximum operating current (125 °C, concurrent R/W)	$\times 18$	1275
	$\times 36$	1275

**Logic Block Diagram – CYRS1543AV18**

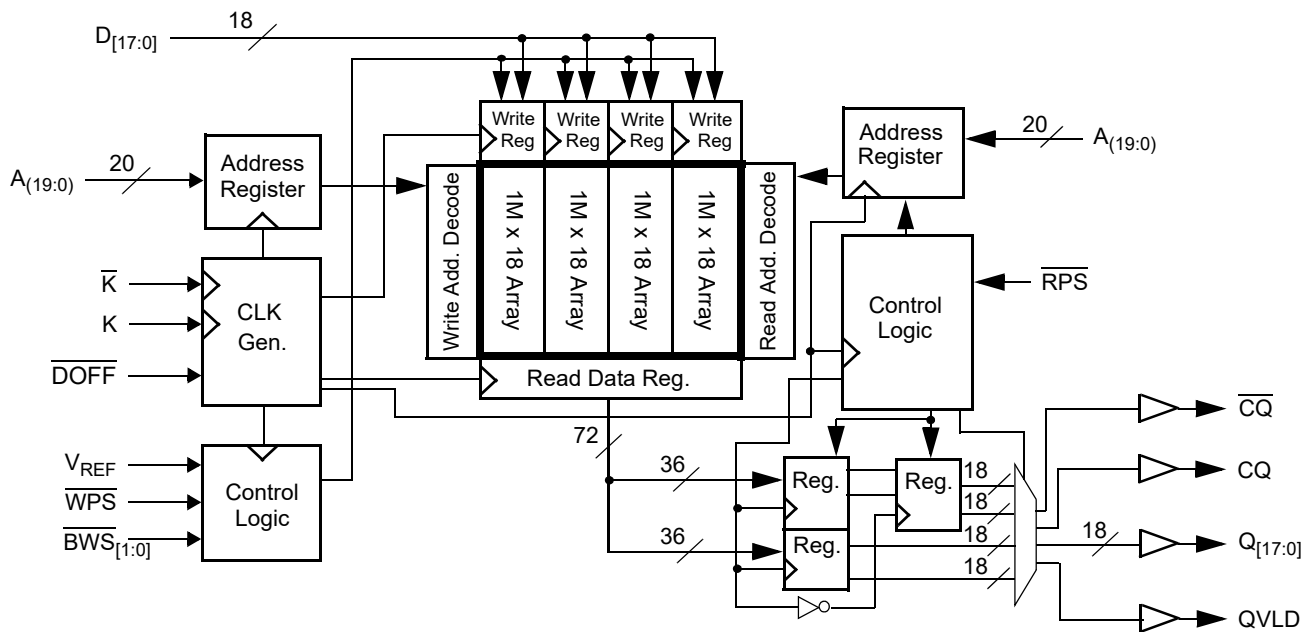

**Logic Block Diagram – CYRS1545AV18**

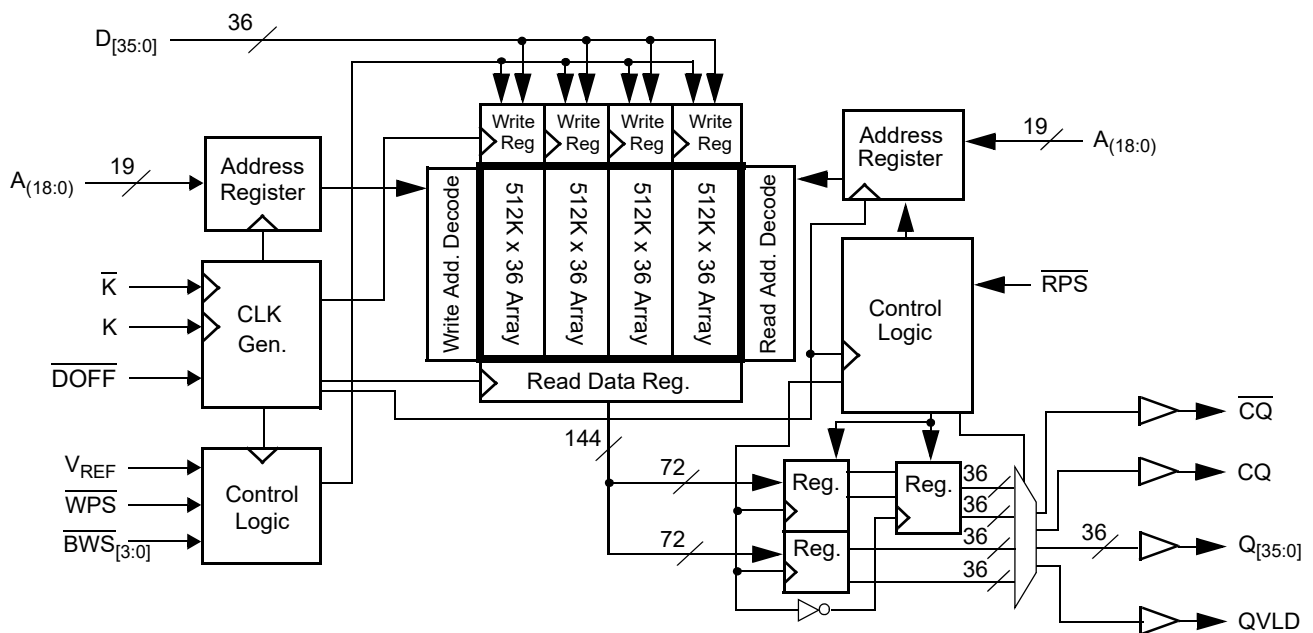

## Contents

<b>Manufacturing Flow</b> .....	<b>4</b>	<b>Scan Register Sizes</b> .....	<b>19</b>
Radiation Hardened Design .....	4	<b>Instruction Codes</b> .....	<b>19</b>
<b>Neutron Soft Error Immunity</b> .....	<b>4</b>	<b>Boundary Scan Order</b> .....	<b>20</b>
<b>Pin Configuration</b> .....	<b>5</b>	<b>Power Up Sequence in QDR II+ SRAM</b> .....	<b>21</b>
<b>Pin Definitions</b> .....	<b>6</b>	Power Up Sequence .....	21
<b>Functional Overview</b> .....	<b>8</b>	DLL Constraints .....	21
Read Operations .....	8	<b>Maximum Ratings</b> .....	<b>22</b>
Write Operations .....	8	<b>Operating Range</b> .....	<b>22</b>
Byte Write Operations .....	8	<b>Electrical Characteristics</b> .....	<b>22</b>
Concurrent Transactions .....	8	DC Electrical Characteristics .....	22
Depth Expansion .....	9	AC Electrical Characteristics .....	23
Programmable Impedance .....	9	<b>Radiation Performance</b> .....	<b>23</b>
Echo Clocks .....	9	<b>Capacitance</b> .....	<b>23</b>
Valid Data Indicator (QVLD) .....	9	<b>Thermal Resistance</b> .....	<b>23</b>
DLL .....	9	<b>AC Test Loads and Waveforms</b> .....	<b>24</b>
Qualification and Screening .....	9	<b>Switching Characteristics</b> .....	<b>25</b>
<b>Application Example</b> .....	<b>10</b>	<b>Switching Waveforms</b> .....	<b>26</b>
<b>Truth Table</b> .....	<b>11</b>	<b>Ordering Information</b> .....	<b>27</b>
<b>Write Cycle Descriptions</b> .....	<b>11</b>	Ordering Code Definitions .....	27
<b>Write Cycle Descriptions</b> .....	<b>12</b>	<b>Package Diagrams</b> .....	<b>28</b>
<b>IEEE 1149.1 Serial Boundary Scan (JTAG)</b> .....	<b>13</b>	<b>Acronyms</b> .....	<b>30</b>
Disabling the JTAG Feature .....	13	<b>Document Conventions</b> .....	<b>30</b>
Test Access Port .....	13	Units of Measure .....	30
Performing a TAP Reset .....	13	<b>Glossary</b> .....	<b>31</b>
TAP Registers .....	13	<b>Document History Page</b> .....	<b>32</b>
TAP Instruction Set .....	13	<b>Sales, Solutions, and Legal Information</b> .....	<b>35</b>
<b>TAP Controller State Diagram</b> .....	<b>15</b>	Worldwide Sales and Design Support .....	35
<b>TAP Controller Block Diagram</b> .....	<b>16</b>	Products .....	35
<b>TAP Electrical Characteristics</b> .....	<b>16</b>	PSoC® Solutions .....	35
<b>TAP AC Switching Characteristics</b> .....	<b>17</b>	Cypress Developer Community .....	35
<b>TAP Timing and Test Conditions</b> .....	<b>18</b>	Technical Support .....	35
<b>Identification Register Definitions</b> .....	<b>19</b>		

## Manufacturing Flow

Step	Screen	Method	Requirement
1	Wafer lot acceptance test	TM 5007	
2	Internal visual	2010, Condition A	100%
3	Serialization		100%
4	Temperature cycling	1010, Condition C, 50 cycles minimum	100%
5	Constant acceleration	2001, YI orientation only	100%
6		Condition TBD (package in design)	
7	Particle impact noise detection (PIND)	2020 Condition A	100%
8	Radiographic (X-Ray)	2012, one view (Y-1 orientation) only	
9	Pre burn in electrical parameters	In accordance with applicable Cypress specification	100%
10	Dynamic burn in	1015, Condition D 240 hours at 125 °C or 120 hours at 150 °C minimum	100%
11	Interim (Post dynamic burn in) electricals	In accordance with applicable Cypress device specifications	100%
12	Static burn in	1015, Condition C, 72 hours at 150 °C or 144 hours at 125 °C minimum	100%
13	Interim (post static burn in) electricals	In accordance with applicable Cypress device specifications	100%
14	Percentage defective allowable (PDA) calculation	5% overall, 3% functional parameters at 25 °C	All lots
15	Final electrical test a. Static tests (1) 25 °C (2) -55 °C and +125 °C b. Functional tests (1) 25 °C (2) -55 °C and +125 °C c. Switching test at 25 °C	In accordance with applicable Cypress device specifications  5005, Table I, Subgroup 1 5005, Table I, Subgroup 2, 3  5005, Table I, Subgroup 7 5005, Table I, Subgroup 8a, 8b 5005, Table I, Subgroup 9	100%
16	Seal (fine and gross leak test)	1014	100%
17	External visual	2009	100%
18	Wafer lot specific life test (Group C)	<a href="#">Mil-PRF 38535</a> , Appendix B, section B.4.2.c	All wafer lots

## Radiation Hardened Design

The single event latch up (SEL) immunity is improved by a radiation hardened design technique developed by Cypress called RadStop. This design mitigation technique allows the SEL performance to achieve radiation hard performance levels.

## Neutron Soft Error Immunity

Parameter	Description	Test Conditions	Typ	Max*	Unit
LSBU	Logical single-bit upsets	25 °C	320	368	FIT/Mb
LMBU	Logical multi-bit upsets	25 °C	0	0.01	FIT/Mb
SEL	Single event latch up	125 °C	0	0.1	FIT/Dev

\* No LMBU or SEL events occurred during testing; this column represents a statistical  $\chi^2$ , 95% confidence limit calculation. For more details refer to Application Note [AN54908](#) "Accelerated Neutron SER Testing and Calculation of Terrestrial Failure Rates"

## Pin Configuration

Pin configurations for CYRS1543AV18 and CYRS1545AV18. [1]

**Figure 1. 165-ball CCGA pinout**

**CYRS1543AV18 (4M × 18)**

	1	2	3	4	5	6	7	8	9	10	11
<b>A</b>	$\overline{\text{CQ}}$	NC/144M	A	$\overline{\text{WPS}}$	$\overline{\text{BWS}}_1$	$\overline{\text{K}}$	NC/288M	$\overline{\text{RPS}}$	A	A	CQ
<b>B</b>	NC	Q9	D9	A	NC	K	$\overline{\text{BWS}}_0$	A	NC	NC	Q8
<b>C</b>	NC	NC	D10	$V_{SS}$	A	NC	A	$V_{SS}$	NC	Q7	D8
<b>D</b>	NC	D11	Q10	$V_{SS}$	$V_{SS}$	$V_{SS}$	$V_{SS}$	$V_{SS}$	NC	NC	D7
<b>E</b>	NC	NC	Q11	$V_{DDQ}$	$V_{SS}$	$V_{SS}$	$V_{SS}$	$V_{DDQ}$	NC	D6	Q6
<b>F</b>	NC	Q12	D12	$V_{DDQ}$	$V_{DD}$	$V_{SS}$	$V_{DD}$	$V_{DDQ}$	NC	NC	Q5
<b>G</b>	NC	D13	Q13	$V_{DDQ}$	$V_{DD}$	$V_{SS}$	$V_{DD}$	$V_{DDQ}$	NC	NC	D5
<b>H</b>	$\overline{\text{DOFF}}$	$V_{REF}$	$V_{DDQ}$	$V_{DDQ}$	$V_{DD}$	$V_{SS}$	$V_{DD}$	$V_{DDQ}$	$V_{DDQ}$	$V_{REF}$	ZQ
<b>J</b>	NC	NC	D14	$V_{DDQ}$	$V_{DD}$	$V_{SS}$	$V_{DD}$	$V_{DDQ}$	NC	Q4	D4
<b>K</b>	NC	NC	Q14	$V_{DDQ}$	$V_{DD}$	$V_{SS}$	$V_{DD}$	$V_{DDQ}$	NC	D3	Q3
<b>L</b>	NC	Q15	D15	$V_{DDQ}$	$V_{SS}$	$V_{SS}$	$V_{SS}$	$V_{DDQ}$	NC	NC	Q2
<b>M</b>	NC	NC	D16	$V_{SS}$	$V_{SS}$	$V_{SS}$	$V_{SS}$	$V_{SS}$	NC	Q1	D2
<b>N</b>	NC	D17	Q16	$V_{SS}$	A	A	A	$V_{SS}$	NC	NC	D1
<b>P</b>	NC	NC	Q17	A	A	QVLD	A	A	NC	D0	Q0
<b>R</b>	TDO	TCK	A	A	A	NC	A	A	A	TMS	TDI

**CYRS1545AV18 (2M × 36)**

	1	2	3	4	5	6	7	8	9	10	11
<b>A</b>	$\overline{\text{CQ}}$	NC/288M	A	$\overline{\text{WPS}}$	$\overline{\text{BWS}}_2$	$\overline{\text{K}}$	$\overline{\text{BWS}}_1$	$\overline{\text{RPS}}$	A	NC/144M	CQ
<b>B</b>	Q27	Q18	D18	A	$\overline{\text{BWS}}_3$	K	$\overline{\text{BWS}}_0$	A	D17	Q17	Q8
<b>C</b>	D27	Q28	D19	$V_{SS}$	A	NC	A	$V_{SS}$	D16	Q7	D8
<b>D</b>	D28	D20	Q19	$V_{SS}$	$V_{SS}$	$V_{SS}$	$V_{SS}$	$V_{SS}$	Q16	D15	D7
<b>E</b>	Q29	D29	Q20	$V_{DDQ}$	$V_{SS}$	$V_{SS}$	$V_{SS}$	$V_{DDQ}$	Q15	D6	Q6
<b>F</b>	Q30	Q21	D21	$V_{DDQ}$	$V_{DD}$	$V_{SS}$	$V_{DD}$	$V_{DDQ}$	D14	Q14	Q5
<b>G</b>	D30	D22	Q22	$V_{DDQ}$	$V_{DD}$	$V_{SS}$	$V_{DD}$	$V_{DDQ}$	Q13	D13	D5
<b>H</b>	$\overline{\text{DOFF}}$	$V_{REF}$	$V_{DDQ}$	$V_{DDQ}$	$V_{DD}$	$V_{SS}$	$V_{DD}$	$V_{DDQ}$	$V_{DDQ}$	$V_{REF}$	ZQ
<b>J</b>	D31	Q31	D23	$V_{DDQ}$	$V_{DD}$	$V_{SS}$	$V_{DD}$	$V_{DDQ}$	D12	Q4	D4
<b>K</b>	Q32	D32	Q23	$V_{DDQ}$	$V_{DD}$	$V_{SS}$	$V_{DD}$	$V_{DDQ}$	Q12	D3	Q3
<b>L</b>	Q33	Q24	D24	$V_{DDQ}$	$V_{SS}$	$V_{SS}$	$V_{SS}$	$V_{DDQ}$	D11	Q11	Q2
<b>M</b>	D33	Q34	D25	$V_{SS}$	$V_{SS}$	$V_{SS}$	$V_{SS}$	$V_{SS}$	D10	Q1	D2
<b>N</b>	D34	D26	Q25	$V_{SS}$	A	A	A	$V_{SS}$	Q10	D9	D1
<b>P</b>	Q35	D35	Q26	A	A	QVLD	A	A	Q9	D0	Q0
<b>R</b>	TDO	TCK	A	A	A	NC	A	A	A	TMS	TDI

**Note**

1. NC/144M and NC/288M are not connected to the die and can be tied to any voltage level.

## Pin Definitions

Pin Name	I/O	Pin Description
$D_{[x:0]}$	Input-Synchronous	<b>Data input signals.</b> Sampled on the rising edge of K and $\bar{K}$ clocks when valid write operations are active. CYRS1543AV18 – $D_{[17:0]}$ CYRS1545AV18 – $D_{[35:0]}$
$\overline{WPS}$	Input-Synchronous	<b>Write port select – Active LOW.</b> Sampled on the rising edge of the K clock. When asserted active, a write operation is initiated. Deasserting deselects the write port. Deselecting the write port ignores $D_{[x:0]}$ .
$\overline{BWS}_0$ , $\overline{BWS}_1$ , $\overline{BWS}_2$ , $\overline{BWS}_3$	Input-Synchronous	<b>Byte write select (BWS) 0, 1, 2, and 3 – Active LOW.</b> Sampled on the rising edge of the K and $\bar{K}$ clocks when write operations are active. Used to select which byte is written into the device during the current portion of the write operations. Bytes not written remain unaltered. CYRS1543AV18 – $\overline{BWS}_0$ controls $D_{[8:0]}$ and $\overline{BWS}_1$ controls $D_{[17:9]}$ . CYRS1545AV18 – $\overline{BWS}_0$ controls $D_{[8:0]}$ , $\overline{BWS}_1$ controls $D_{[17:9]}$ , $\overline{BWS}_2$ controls $D_{[26:18]}$ and $\overline{BWS}_3$ controls $D_{[35:27]}$ . All the BWS are sampled on the same edge as the data. Deselecting a BWS ignores the corresponding byte of data and it is not written into the device.
$A_{[x:0]}$	Input-Synchronous	<b>Address inputs.</b> Sampled on the rising edge of the K clock during active read and write operations. These address inputs are multiplexed for both read and write operations. Internally, the device is organized as $4M \times 18$ (4 arrays each of $1M \times 18$ ) for CYRS1543AV18 and $2M \times 36$ (4 arrays each of $512K \times 36$ ) for CYRS1545AV18. Therefore, only 20 address inputs for CYRS1543AV18 and 19 address inputs for CYRS1545AV18. These inputs are ignored when the appropriate port is deselected.
$Q_{[x:0]}$	Outputs-Synchronous	<b>Data output signals.</b> These pins drive out the requested data when the read operation is active. Valid data is driven out on the rising edge of the K and $\bar{K}$ clocks during read operations. On deselecting the read port, $Q_{[x:0]}$ are automatically tristated. CYRS1543AV18 – $Q_{[17:0]}$ CYRS1545AV18 – $Q_{[35:0]}$
RPS	Input-Synchronous	<b>Read port select – Active LOW.</b> Sampled on the rising edge of positive input clock (K). When active, a read operation is initiated. Deasserting deselects the read port. When deselected, the pending access is allowed to complete and the output drivers are automatically tristated following the next rising edge of the K clock. Each read access consists of a burst of four sequential transfers.
QVLD	Valid Output Indicator	<b>Valid output indicator.</b> The Q Valid indicates valid output data. QVLD is edge aligned with $\overline{CQ}$ and $\overline{CQ}$ .
K	Input Clock	<b>Positive input clock input.</b> The rising edge of K is used to capture synchronous inputs to the device and to drive out data through $Q_{[x:0]}$ when in single clock mode. All accesses are initiated on the rising edge of K.
$\bar{K}$	Input Clock	<b>Negative input clock input.</b> $\bar{K}$ is used to capture synchronous inputs being presented to the device and to drive out data through $Q_{[x:0]}$ when in single clock mode.
CQ	Echo Clock	<b>Synchronous echo clock outputs.</b> This is a free running clock and is synchronized to the input clock K. The timings for the echo clocks are shown in the <a href="#">Switching Characteristics on page 25</a> .
$\overline{CQ}$	Echo Clock	<b>Synchronous echo clock outputs.</b> This is a free running clock and is synchronized to the input clock K. The timings for the echo clocks are shown in the <a href="#">Switching Characteristics on page 25</a> .
ZQ	Input	<b>Output impedance matching input.</b> This input is used to tune the device outputs to the system data bus impedance. CQ, $\overline{CQ}$ , and $Q_{[x:0]}$ output impedance are set to $0.2 \times RQ$ , where RQ is a resistor connected between ZQ and ground. Alternatively, this pin can be connected directly to $V_{DDQ}$ , which enables the minimum impedance mode. This pin cannot be connected directly to GND or left unconnected.
$\overline{DOFF}$	Input	<b>DLL turn off – Active LOW.</b> Connecting this pin to ground turns off the DLL inside the device. The timings in the DLL turned off operation differs from those listed in this data sheet. For normal operation, this pin can be connected to a pull up through a 10 K $\Omega$ or less pull up resistor. The device behaves in QDR I mode when the DLL is turned off. In this mode, the device can be operated at a frequency of up to 167 MHz with QDR I timing.
TDO	Output	<b>Test data out (TDO) Pin for JTAG.</b>
TCK	Input	<b>Test clock (TCK) Pin for JTAG.</b>

**Pin Definitions** (continued)

Pin Name	I/O	Pin Description
TDI	Input	<b>Test data in (TDI) Pin for JTAG.</b>
TMS	Input	<b>Test mode select (TMS) Pin for JTAG.</b>
NC	N/A	<b>Not connected to the die.</b> Can be tied to any voltage level.
NC/144M	N/A	<b>Not connected to the die.</b> Can be tied to any voltage level.
NC/288M	N/A	<b>Not connected to the die.</b> Can be tied to any voltage level.
V <sub>REF</sub>	Input-Reference	<b>Reference voltage input.</b> Static input used to set the reference level for HSTL inputs, outputs, and AC measurement points.
V <sub>DD</sub>	Power Supply	<b>Power supply inputs to the core of the device.</b>
V <sub>SS</sub>	Ground	<b>Ground for the device.</b>
V <sub>DDQ</sub>	Power Supply	<b>Power supply inputs for the outputs of the device.</b>



## Functional Overview

The CYRS1543AV18, CYRS1545AV18 are synchronous pipelined burst SRAMs with a read port and a write port. The read port is dedicated to read operations and the write port is dedicated to write operations. Data flows into the SRAM through the write port and flows out through the read port. These devices multiplex the address inputs to minimize the number of address pins required. By having separate read and write ports, the QDR II completely eliminates the need to turnaround the data bus and avoids any possible data contention, thereby simplifying system design. Each access consists of four 18-bit data transfers in the case of CYRS1543AV18, and four 36-bit data transfers in the case of CYRS1545AV18 in two clock cycles.

This device operates with a read latency of two cycles when  $\overline{\text{DOFF}}$  pin is tied HIGH. When  $\overline{\text{DOFF}}$  pin is set LOW or connected to  $V_{SS}$  then device behaves in QDR I mode with a read latency of one clock cycle.  $\overline{\text{DOFF}}$  is not a recommended mode of operation.

Accesses for both ports are initiated on the positive input clock (K). All synchronous input timing is referenced from the rising edge of the input clocks (K and  $\overline{K}$ ) and all output timing is referenced to the output clocks (K and  $\overline{K}$ ).

All synchronous data inputs ( $D_{[x:0]}$ ) pass through input registers controlled by the input clocks (K and  $\overline{K}$ ). All synchronous data outputs ( $Q_{[x:0]}$ ) pass through output registers controlled by the rising edge of the output clocks (K and  $\overline{K}$ ).

All synchronous control ( $\overline{\text{RPS}}$ ,  $\overline{\text{WPS}}$ ,  $\overline{\text{BWS}}_{[x:0]}$ ) inputs pass through input registers controlled by the rising edge of the input clocks (K and  $\overline{K}$ ).

CYRS1543AV18 is described below. The same basic descriptions also apply to CYRS1545AV18.

### Read Operations

The CYRS1543AV18 is organized internally as four arrays of  $1M \times 18$ . Accesses are completed in a burst of four sequential 18-bit data words. Read operations are initiated by asserting  $\overline{\text{RPS}}$  active at the rising edge of the positive input clock (K). The address presented to the address inputs is stored in the read address register. Following the next two K clock rising edges, the corresponding lower order 18-bit word of data is driven onto the  $Q_{[17:0]}$  using K as the output timing reference. On the subsequent rising edge of  $\overline{K}$ , the next 18-bit data word is driven onto the  $Q_{[17:0]}$ . This process continues until all four 18-bit data words have been driven out onto  $Q_{[17:0]}$ . The requested data is valid 0.45 ns from the rising edge of the output clock (K or  $\overline{K}$ ). To maintain the internal logic, each read access must be allowed to complete. Each read access consists of four 18-bit data words and takes two clock cycles to complete. Therefore, read accesses to the device can not be initiated on two consecutive K clock rises. The internal logic of the device ignores the second read request. Read accesses can be initiated on every other K clock rise. Doing so pipelines the data flow such that data is transferred out of the device on every rising edge of the output clocks (K or  $\overline{K}$ ).

When the read port is deselected, the CYRS1543AV18 first completes the pending read transactions. Synchronous internal

circuitry automatically tri-states the outputs following the next rising edge of the positive input clock (K).

### Write Operations

Write operations are initiated by asserting  $\overline{\text{WPS}}$  active at the rising edge of the positive input clock (K). On the following K clock rise the data presented to  $D_{[17:0]}$  is latched and stored into the lower 18-bit write data register, provided  $\overline{\text{BWS}}_{[1:0]}$  are both asserted active. On the subsequent rising edge of the negative input clock ( $\overline{K}$ ) the information presented to  $D_{[17:0]}$  is stored into the higher 18-bit write data register, provided  $\overline{\text{BWS}}_{[1:0]}$  are both asserted active. This process continues for one more cycle until four 18-bit words (a total of 72 bits) of data are stored in the SRAM. The 72 bits of data are then written into the memory array at the specified location. Therefore, write accesses to the device can not be initiated on two consecutive K clock rises. The internal logic of the device ignores the second write request. Write accesses can be initiated on every other rising edge of the positive input clock (K). Doing so pipelines the data flow such that 18 bits of data can be transferred into the device on every rising edge of the input clocks (K and  $\overline{K}$ ).

When deselected, the write port ignores all inputs after the pending write operations have been completed.

### Byte Write Operations

Byte write operations are supported by the CYRS1543AV18. A write operation is initiated as described in the [Write Operations](#) section. The bytes that are written are determined by  $\overline{\text{BWS}}_0$  and  $\overline{\text{BWS}}_1$ , which are sampled with each set of 18-bit data words. Asserting the appropriate BWS input during the data portion of a write latches the data being presented and writes it into the device. Deasserting the BWS input during the data portion of a write allows the data stored in the device for that byte to remain unaltered. This feature can be used to simplify read, modify, or write operations to a byte write operation.

### Concurrent Transactions

The read and write ports on the CYRS1543AV18 operate independently of one another. As each port latches the address inputs on different clock edges, you can read or write to any location, regardless of the transaction on the other port. If the ports access the same location when a read follows a write in successive clock cycles, the SRAM delivers the most recent information associated with the specified address location. This includes forwarding data from a write cycle that was initiated on the previous K clock rise.

Read access and write access must be scheduled such that one transaction is initiated on any clock cycle. If both ports are selected on the same K clock rise, the arbitration depends on the previous state of the SRAM. If both ports are deselected, the read port takes priority. If a read was initiated on the previous cycle, the write port takes priority (as read operations can not be initiated on consecutive cycles). If a write was initiated on the previous cycle, the read port takes priority (as write operations can not be initiated on consecutive cycles). Therefore, asserting both port selects active from a deselected state results in alternating read or write operations being initiated, with the first access being a read.



### Depth Expansion

The CYRS1543AV18 has a port select input for each port. This allows for easy depth expansion. Both port selects are sampled on the rising edge of the positive input clock only (K). Each port select input can deselect the specified port. Deselecting a port does not affect the other port. All pending transactions (read and write) are completed before the device is deselected.

### Programmable Impedance

An external resistor, RQ, must be connected between the ZQ pin on the SRAM and V<sub>SS</sub> to allow the SRAM to adjust its output driver impedance. The value of RQ must be 5 × the value of the intended line impedance driven by the SRAM, the allowable range of RQ to guarantee impedance matching with a tolerance of ±15% is between 175 Ω and 350 Ω, with V<sub>DDQ</sub> = 1.5 V. The output impedance is adjusted every 1024 cycles upon power up to account for drifts in supply voltage and temperature.

### Echo Clocks

Echo clocks are provided on the QDR II+ to simplify data capture on high-speed systems. Two echo clocks are generated by the QDR II+. CQ is referenced with respect to K and CQ is referenced with respect to K. These are free-running clocks and are synchronized to the input clock of the QDR II+. The timing for the echo clocks is shown in the [Switching Characteristics on page 25](#).

### Valid Data Indicator (QVLD)

QVLD is provided on the QDR II+ to simplify data capture on high speed systems. The QVLD is generated by the QDR II+ device along with data output. This signal is also edge-aligned with the echo clock and follows the timing of any data pin. This signal is asserted half a cycle before valid data arrives.

### DLL

These chips use a DLL that is designed to function between 120 MHz and the specified maximum clock frequency. During power up, when the  $\overline{\text{DOFF}}$  is tied HIGH, the DLL is locked after 10240 cycles of stable clock. The DLL can also be reset by slowing or stopping the input clocks K and K for a minimum of 30 ns. The DLL may be disabled by applying ground to the  $\overline{\text{DOFF}}$  pin. When the DLL is turned off, the device behaves in QDR I mode (with one cycle latency and a longer access time). For information refer to the application note AN5062, [DLL Considerations in QDRII/DDRII](#).

### Qualification and Screening

The 90 nm RadStop technology was qualified by Cypress after meeting the criteria of the General Manufacturing Standards. The test flow includes screening units with the defined flow (Class Q, Class V) and the appropriate periodic or lot conformance testing (Groups B, C, D, and E). Both the 90 nm process and the SRAM products are subject to period or lot based technology conformance inspection (TCI) and quality conformance inspection (QCI) tests, respectively. Cypress offers both prototyping models and flight units of these product configurations.

**Table 1. Qualification Tests**

Groups	Tests
Group A	General electrical tests
Group B	Mechanical - Dimensions, bond strength, solvents, die shear, solderability, lead integrity, seal, and acceleration
Group C	Life tests - 1000 hours at 125 °C or equivalent
Group D	Package related mechanical tests - shock, vibration, accel, salt, seal, lead finish adhesion, lid torque, thermal shock, and moisture resistance
Group E	Radiation tests

## Application Example

Figure 2 shows two QDR II+ used in an application.

Figure 2. Application Example

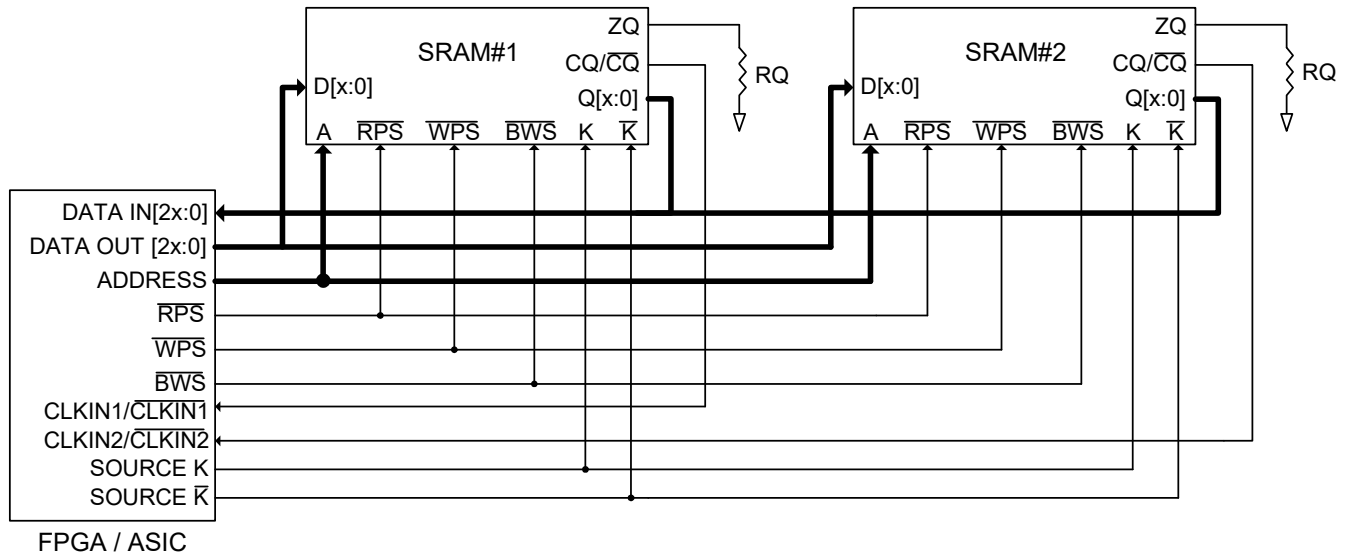

## Truth Table

CYRS1543AV18 and CYRS1545AV18 [2, 3, 4, 5, 6, 7]

Operation	K	RPS	WPS	DQ	DQ	DQ	DQ
Write cycle: Load address on the rising edge of K; input write data on two consecutive K and $\bar{K}$ rising edges.	L-H	H [8]	L [9]	D(A) at K(t + 1)↑	D(A + 1) at $\bar{K}(t + 1)$ ↑	D(A + 2) at K(t + 2)↑	D(A + 3) at $\bar{K}(t + 2)$ ↑
Read cycle: (2.0 Cycle Latency) Load address on the rising edge of K; wait two cycles; read data on two consecutive K and $\bar{K}$ rising edges.	L-H	L [9]	X	Q(A) at K(t + 2)↑	Q(A + 1) at $\bar{K}(t + 2)$ ↑	Q(A + 2) at K(t + 3)↑	Q(A + 3) at $\bar{K}(t + 3)$ ↑
NOP: No operation	L-H	H	H	D = X Q = High Z	D = X Q = High Z	D = X Q = High Z	D = X Q = High Z
Standby: Clock stopped	Stopped	X	X	Previous state	Previous state	Previous state	Previous state

## Write Cycle Descriptions

CYRS1543AV18 [2, 10]

$\overline{BWS}_0$	$\overline{BWS}_1$	K	$\bar{K}$	Comments
L	L	L-H	-	During the data portion of a write sequence: CYRS1543AV18 – both bytes ( $D_{[17:0]}$ ) are written into the device.
L	L	-	L-H	During the data portion of a write sequence: CYRS1543AV18 – both bytes ( $D_{[17:0]}$ ) are written into the device.
L	H	L-H	-	During the data portion of a write sequence: CYRS1543AV18 – only the lower byte ( $D_{[8:0]}$ ) is written into the device, $D_{[17:9]}$ remains unaltered.
L	H	-	L-H	During the data portion of a write sequence: CYRS1543AV18 – only the lower byte ( $D_{[8:0]}$ ) is written into the device, $D_{[17:9]}$ remains unaltered.
H	L	L-H	-	During the data portion of a write sequence: CYRS1543AV18 – only the upper byte ( $D_{[17:9]}$ ) is written into the device, $D_{[8:0]}$ remains unaltered.
H	L	-	L-H	During the data portion of a write sequence: CYRS1543AV18 – only the upper byte ( $D_{[17:9]}$ ) is written into the device, $D_{[8:0]}$ remains unaltered.
H	H	L-H	-	No data is written into the devices during this portion of a write operation.
H	H	-	L-H	No data is written into the devices during this portion of a write operation.

### Notes

- X = "Don't Care," H = Logic HIGH, L = Logic LOW, ↑ represents rising edge.
- Device powers up deselected with the outputs in a tristate condition.
- "A" represents address location latched by the devices when transaction was initiated. A + 1, A + 2, and A + 3 represents the address sequence in the burst.
- "t" represents the cycle at which a read/write operation is started. t + 1, t + 2, and t + 3 are the first, second and third clock cycles respectively succeeding the "t" clock cycle.
- Data inputs are registered at K and  $\bar{K}$  rising edges. Data outputs are delivered on K and  $\bar{K}$  rising edges.
- We recommend that K =  $\bar{K}$  = HIGH when clock is stopped. This is not essential, but permits most rapid restart by overcoming transmission line charging symmetrically.
- If this signal was LOW to initiate the previous cycle, this signal becomes a "Don't Care" for this operation.
- This signal was HIGH on previous K clock rise. Initiating consecutive read or write operations on consecutive K clock rises is not permitted. The device ignores the second read or write request.
- Is based on a write cycle that was initiated in accordance with the [Write Cycle Descriptions](#) table.  $\overline{BWS}_0$ ,  $\overline{BWS}_1$ ,  $\overline{BWS}_2$ , and  $\overline{BWS}_3$  can be altered on different portions of a write cycle, as long as the setup and hold requirements are achieved.

## Write Cycle Descriptions

The write cycle description table for CYRS1545AV18 follows. [11, 12]

$\overline{\text{BWS}}_0$	$\overline{\text{BWS}}_1$	$\overline{\text{BWS}}_2$	$\overline{\text{BWS}}_3$	K	$\overline{\text{K}}$	Comments
L	L	L	L	L-H	-	During the data portion of a write sequence, all four bytes ( $D_{[35:0]}$ ) are written into the device.
L	L	L	L	-	L-H	During the data portion of a write sequence, all four bytes ( $D_{[35:0]}$ ) are written into the device.
L	H	H	H	L-H	-	During the data portion of a write sequence, only the lower byte ( $D_{[8:0]}$ ) is written into the device. $D_{[35:9]}$ remains unaltered.
L	H	H	H	-	L-H	During the data portion of a write sequence, only the lower byte ( $D_{[8:0]}$ ) is written into the device. $D_{[35:9]}$ remains unaltered.
H	L	H	H	L-H	-	During the data portion of a write sequence, only the byte ( $D_{[17:9]}$ ) is written into the device. $D_{[8:0]}$ and $D_{[35:18]}$ remains unaltered.
H	L	H	H	-	L-H	During the data portion of a write sequence, only the byte ( $D_{[17:9]}$ ) is written into the device. $D_{[8:0]}$ and $D_{[35:18]}$ remains unaltered.
H	H	L	H	L-H	-	During the data portion of a write sequence, only the byte ( $D_{[26:18]}$ ) is written into the device. $D_{[17:0]}$ and $D_{[35:27]}$ remains unaltered.
H	H	L	H	-	L-H	During the data portion of a write sequence, only the byte ( $D_{[26:18]}$ ) is written into the device. $D_{[17:0]}$ and $D_{[35:27]}$ remains unaltered.
H	H	H	L	L-H	-	During the data portion of a write sequence, only the byte ( $D_{[35:27]}$ ) is written into the device. $D_{[26:0]}$ remains unaltered.
H	H	H	L	-	L-H	During the data portion of a write sequence, only the byte ( $D_{[35:27]}$ ) is written into the device. $D_{[26:0]}$ remains unaltered.
H	H	H	H	L-H	-	No data is written into the device during this portion of a write operation.
H	H	H	H	-	L-H	No data is written into the device during this portion of a write operation.

### Notes

11. X = "Don't Care," H = Logic HIGH, L = Logic LOW,  $\uparrow$  represents rising edge.

12. Is based on a write cycle that was initiated in accordance with the [Write Cycle Descriptions](#) table.  $\overline{\text{NWS}}_0$ ,  $\overline{\text{NWS}}_1$ ,  $\overline{\text{BWS}}_0$ ,  $\overline{\text{BWS}}_1$ ,  $\overline{\text{BWS}}_2$ , and  $\overline{\text{BWS}}_3$  can be altered on different portions of a write cycle, as long as the setup and hold requirements are achieved.

## IEEE 1149.1 Serial Boundary Scan (JTAG)

These SRAMs incorporate a serial boundary scan Test Access Port (TAP) in the FBGA package. This part is fully compliant with IEEE Standard #1149.1-2001. The TAP operates using JEDEC standard 1.8 V I/O logic levels.

### Disabling the JTAG Feature

It is possible to operate the SRAM without using the JTAG feature. To disable the TAP controller, TCK must be tied LOW ( $V_{SS}$ ) to prevent clocking of the device. TDI and TMS are internally pulled up and may be unconnected. They may alternatively be connected to  $V_{DD}$  through a pull up resistor. TDO must be left unconnected. Upon power up, the device comes up in a reset state, which does not interfere with the operation of the device.

### Test Access Port

#### Test Clock

The test clock is used only with the TAP controller. All inputs are captured on the rising edge of TCK. All outputs are driven from the falling edge of TCK.

#### Test Mode Select (TMS)

The TMS input is used to give commands to the TAP controller and is sampled on the rising edge of TCK. This pin may be left unconnected if the TAP is not used. The pin is pulled up internally, resulting in a logic HIGH level.

#### Test Data In (TDI)

The TDI pin is used to serially input information into the registers and can be connected to the input of any of the registers. The register between TDI and TDO is chosen by the instruction that is loaded into the TAP instruction register. For information on loading the instruction register, see the [TAP Controller State Diagram on page 15](#). TDI is internally pulled up and can be unconnected if the TAP is unused in an application. TDI is connected to the most significant bit (MSB) on any register.

#### Test Data Out (TDO)

The TDO output pin is used to serially clock data out from the registers. The output is active, depending upon the current state of the TAP state machine (see [Instruction Codes on page 19](#)). The output changes on the falling edge of TCK. TDO is connected to the least significant bit (LSB) of any register.

### Performing a TAP Reset

A reset is performed by forcing TMS HIGH ( $V_{DD}$ ) for five rising edges of TCK. This reset does not affect the operation of the SRAM and can be performed while the SRAM is operating. At power up, the TAP is reset internally to ensure that TDO comes up in a high Z state.

### TAP Registers

Registers are connected between the TDI and TDO pins to scan the data in and out of the SRAM test circuitry. Only one register can be selected at a time through the instruction registers. Data is serially loaded into the TDI pin on the rising edge of TCK. Data is output on the TDO pin on the falling edge of TCK.

#### Instruction Register

Three-bit instructions can be serially loaded into the instruction register. This register is loaded when it is placed between the TDI and TDO pins, as shown in [TAP Controller Block Diagram on page 16](#). Upon power up, the instruction register is loaded with the IDCODE instruction. It is also loaded with the IDCODE instruction if the controller is placed in a reset state, as described in the previous section.

When the TAP controller is in the Capture-IR state, the two least significant bits are loaded with a binary "01" pattern to allow for fault isolation of the board level serial test path.

#### Bypass Register

To save time when serially shifting data through registers, it is sometimes advantageous to skip certain chips. The bypass register is a single-bit register that can be placed between TDI and TDO pins. This enables shifting of data through the SRAM with minimal delay. The bypass register is set LOW ( $V_{SS}$ ) when the BYPASS instruction is executed.

#### Boundary Scan Register

The boundary scan register is connected to all of the input and output pins on the SRAM. Several no connect (NC) pins are also included in the scan register to reserve pins for higher density devices.

The boundary scan register is loaded with the contents of the RAM input and output ring when the TAP controller is in the Capture-DR state and is then placed between the TDI and TDO pins when the controller is moved to the Shift-DR state. The EXTEST, SAMPLE/PRELOAD, and SAMPLE Z instructions can be used to capture the contents of the input and output ring.

The [Boundary Scan Order on page 20](#) shows the order in which the bits are connected. Each bit corresponds to one of the bumps on the SRAM package. The MSB of the register is connected to TDI, and the LSB is connected to TDO.

#### Identification (ID) Register

The ID register is loaded with a vendor-specific, 32-bit code during the Capture-DR state when the IDCODE command is loaded in the instruction register. The IDCODE is hardwired into the SRAM and can be shifted out when the TAP controller is in the Shift-DR state. The ID register has a vendor code and other information described in [Identification Register Definitions on page 19](#).

### TAP Instruction Set

Eight different instructions are possible with the three-bit instruction register. All combinations are listed in [Instruction Codes on page 19](#). Three of these instructions are listed as RESERVED and must not be used. The other five instructions are described in this section in detail.

Instructions are loaded into the TAP controller during the Shift-IR state when the instruction register is placed between TDI and TDO. During this state, instructions are shifted through the instruction register through the TDI and TDO pins. To execute the instruction after it is shifted in, the TAP controller must be moved into the Update-IR state.

### *IDCODE*

The IDCODE instruction loads a vendor-specific, 32-bit code into the instruction register. It also places the instruction register between the TDI and TDO pins and shifts the IDCODE out of the device when the TAP controller enters the Shift-DR state. The IDCODE instruction is loaded into the instruction register at power up or whenever the TAP controller is supplied a Test-Logic-Reset state.

### *SAMPLE Z*

The SAMPLE Z instruction connects the boundary scan register between the TDI and TDO pins when the TAP controller is in a Shift-DR state. The SAMPLE Z command puts the output bus into a high Z state until the next command is supplied during the Update IR state.

### *SAMPLE/PRELOAD*

SAMPLE/PRELOAD is an 1149.1 mandatory instruction. When the SAMPLE/PRELOAD instructions are loaded into the instruction register and the TAP controller is in the Capture-DR state, a snapshot of data on the input and output pins is captured in the boundary scan register.

You must be aware that the TAP controller clock only operates at a frequency up to 20 MHz, while the SRAM clock operates more than an order of magnitude faster. Because there is a large difference in the clock frequencies, it is possible that during the Capture-DR state, an input or output undergoes a transition. The TAP may then try to capture a signal while in transition (metastable state). This does not harm the device, but there is no guarantee as to the value that is captured. Repeatable results may not be possible.

To guarantee that the boundary scan register captures the correct value of a signal, the SRAM signal must be stabilized long enough to meet the TAP controller's capture setup plus hold times ( $t_{CS}$  and  $t_{CH}$ ). The SRAM clock input might not be captured correctly if there is no way in a design to stop (or slow) the clock during a SAMPLE/PRELOAD instruction. If this is an issue, it is still possible to capture all other signals and simply ignore the value of the K and K captured in the boundary scan register.

After the data is captured, it is possible to shift out the data by putting the TAP into the Shift-DR state. This places the boundary scan register between the TDI and TDO pins.

PRELOAD places an initial data pattern at the latched parallel outputs of the boundary scan register cells before the selection of another boundary scan test operation.

The shifting of data for the SAMPLE and PRELOAD phases can occur concurrently when required, that is, while the data captured is shifted out, the preloaded data can be shifted in.

### *BYPASS*

When the BYPASS instruction is loaded in the instruction register and the TAP is placed in a Shift-DR state, the bypass register is placed between the TDI and TDO pins. The advantage of the BYPASS instruction is that it shortens the boundary scan path when multiple devices are connected together on a board.

### *EXTEST*

The EXTEST instruction drives the preloaded data out through the system output pins. This instruction also connects the boundary scan register for serial access between the TDI and TDO in the Shift-DR controller state.

### *EXTEST OUTPUT BUS TRISTATE*

IEEE Standard 1149.1 mandates that the TAP controller be able to put the output bus into a tristate mode.

The boundary scan register has a special bit located at bit #108. When this scan cell, called the "extest output bus tristate," is latched into the preload register during the Update-DR state in the TAP controller, it directly controls the state of the output (Q-bus) pins, when the EXTEST is entered as the current instruction. When HIGH, it enables the output buffers to drive the output bus. When LOW, this bit places the output bus into a high Z condition.

This bit can be set by entering the SAMPLE/PRELOAD or EXTEST command, and then shifting the desired bit into that cell, during the Shift-DR state. During Update-DR, the value loaded into that shift-register cell latches into the preload register. When the EXTEST instruction is entered, this bit directly controls the output Q-bus pins. Note that this bit is preset HIGH to enable the output when the device is powered up, and also when the TAP controller is in the Test-Logic-Reset state.

### *Reserved*

These instructions are not implemented but are reserved for future use. Do not use these instructions.

### TAP Controller State Diagram

The state diagram for the TAP controller follows. <sup>[13]</sup>

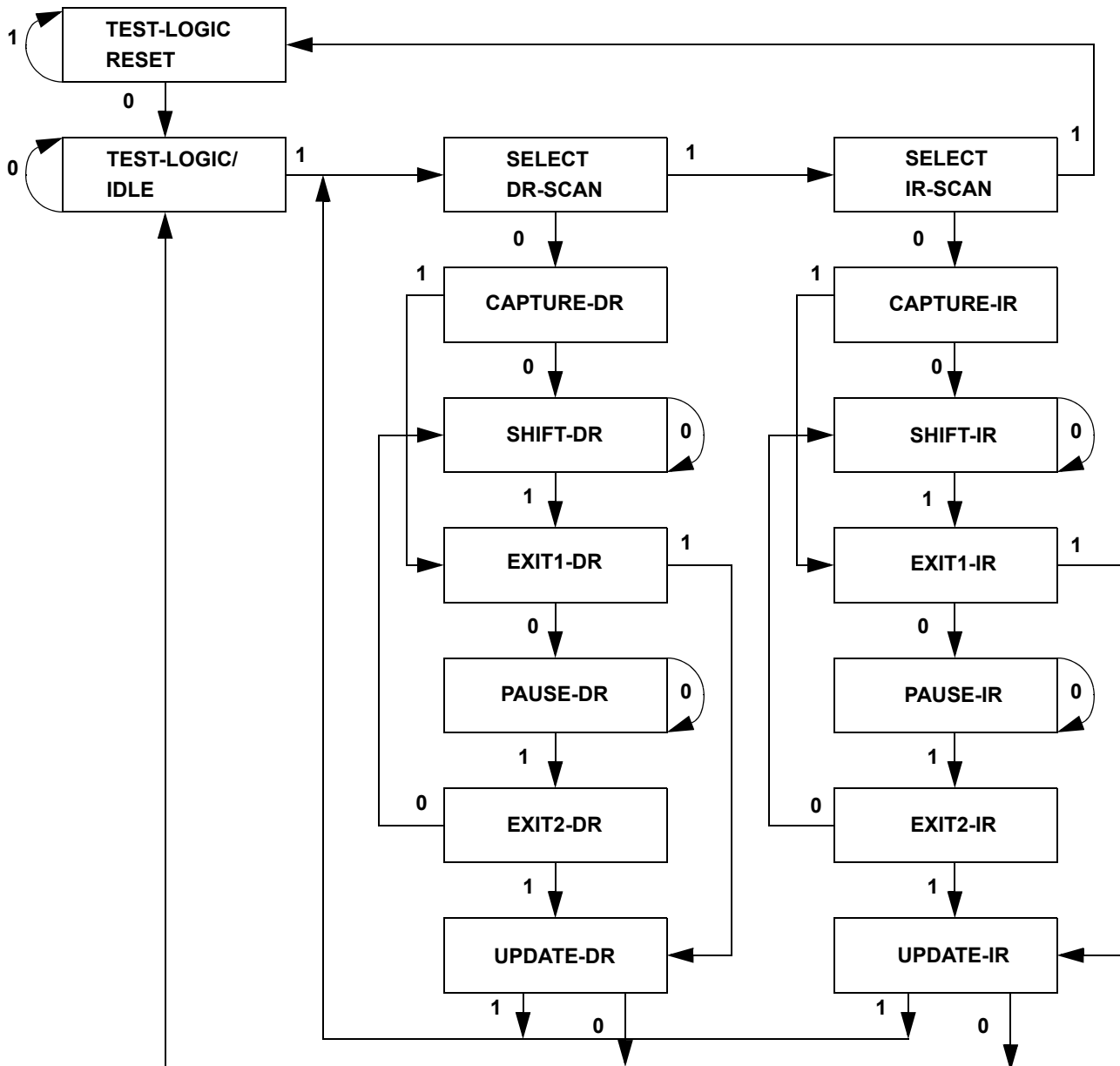

**Note**

13. The 0/1 next to each state represents the value at TMS at the rising edge of TCK.



## TAP Controller Block Diagram

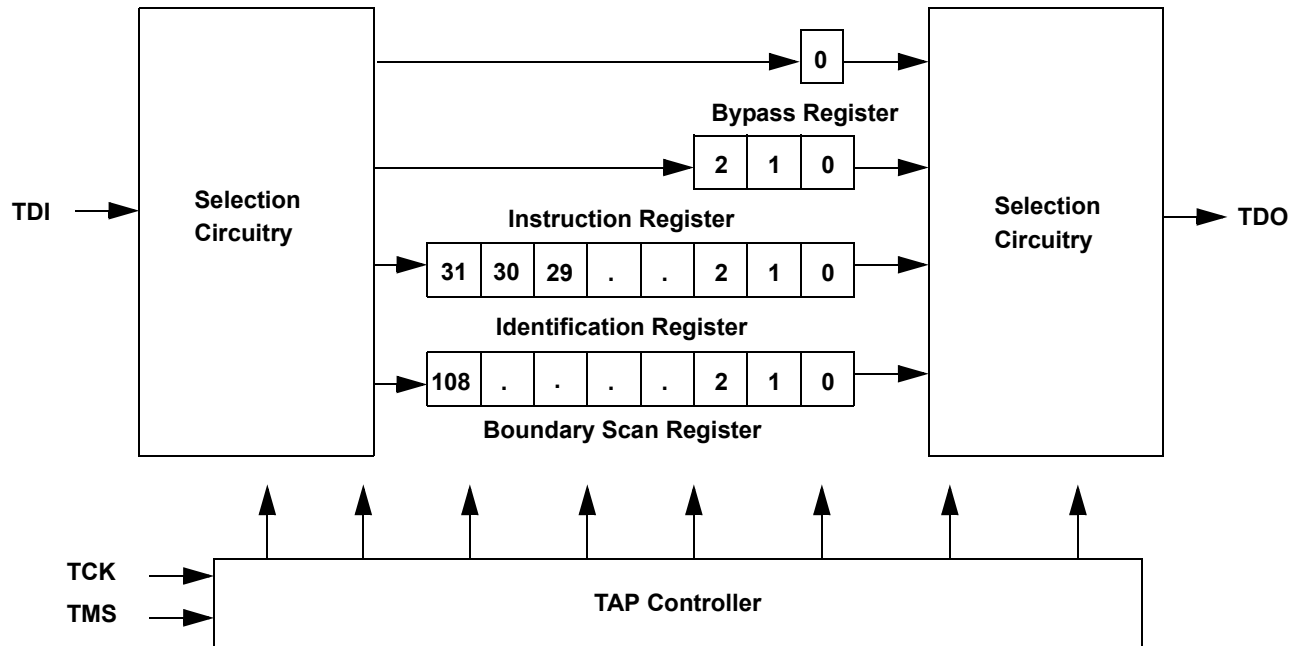

## TAP Electrical Characteristics

Over the Operating Range

Parameter <sup>[14, 15, 16]</sup>	Description	Test Conditions	Min	Max	Unit
V <sub>OH1</sub>	Output HIGH voltage	I <sub>OH</sub> = -2.0 mA	1.4	-	V
V <sub>OH2</sub>	Output HIGH voltage	I <sub>OH</sub> = -100 μA	1.6	-	V
V <sub>OL1</sub>	Output LOW voltage	I <sub>OL</sub> = 2.0 mA	-	0.4	V
V <sub>OL2</sub>	Output LOW voltage	I <sub>OL</sub> = 100 μA	-	0.2	V
V <sub>IH</sub>	Input HIGH voltage		0.65 × V <sub>DD</sub>	V <sub>DD</sub> + 0.3	V
V <sub>IL</sub>	Input LOW voltage		-0.3	0.35 × V <sub>DD</sub>	V
I <sub>X</sub>	Input and output load current	GND ≤ V <sub>I</sub> ≤ V <sub>DD</sub>	-5	5	μA

### Notes

14. These characteristics pertain to the TAP inputs (TMS, TCK, TDI and TDO). Parallel load levels are specified in [Electrical Characteristics on page 22](#).
15. Overshoot: V<sub>IH(AC)</sub> < V<sub>DDQ</sub> + 0.85 V (Pulse width less than t<sub>CYC/2</sub>), Undershoot: V<sub>IL(AC)</sub> > -1.5 V (Pulse width less than t<sub>CYC/2</sub>).
16. All Voltage referenced to Ground.

## TAP AC Switching Characteristics

Over the Operating Range

Parameter <sup>[17, 18]</sup>	Description	Min	Max	Unit
$t_{TCYC}$	TCK clock cycle time	50	–	ns
$t_{TF}$	TCK clock frequency	–	20	MHz
$t_{TH}$	TCK clock HIGH	20	–	ns
$t_{TL}$	TCK clock LOW	20	–	ns
<b>Setup Times</b>				
$t_{TMSS}$	TMS setup to TCK clock rise	5	–	ns
$t_{TDIS}$	TDI setup to TCK clock rise	5	–	ns
$t_{CS}$	Capture setup to TCK rise	5	–	ns
<b>Hold Times</b>				
$t_{TMSh}$	TMS hold after TCK clock rise	5	–	ns
$t_{TDIH}$	TDI hold after clock rise	5	–	ns
$t_{CH}$	Capture hold after clock rise	5	–	ns
<b>Output Times</b>				
$t_{TDOV}$	TCK clock LOW to TDO valid	–	10	ns
$t_{TDOX}$	TCK clock LOW to TDO invalid	0	–	ns

### Notes

17.  $t_{CS}$  and  $t_{CH}$  refer to the setup and hold time requirements of latching data from the boundary scan register.  
18. Test conditions are specified using the load in TAP AC Test Conditions.  $t_R/t_F = 1$  ns.

### TAP Timing and Test Conditions

Figure 3 shows the TAP timing and test conditions. [19]

Figure 3. TAP Timing and Test Conditions

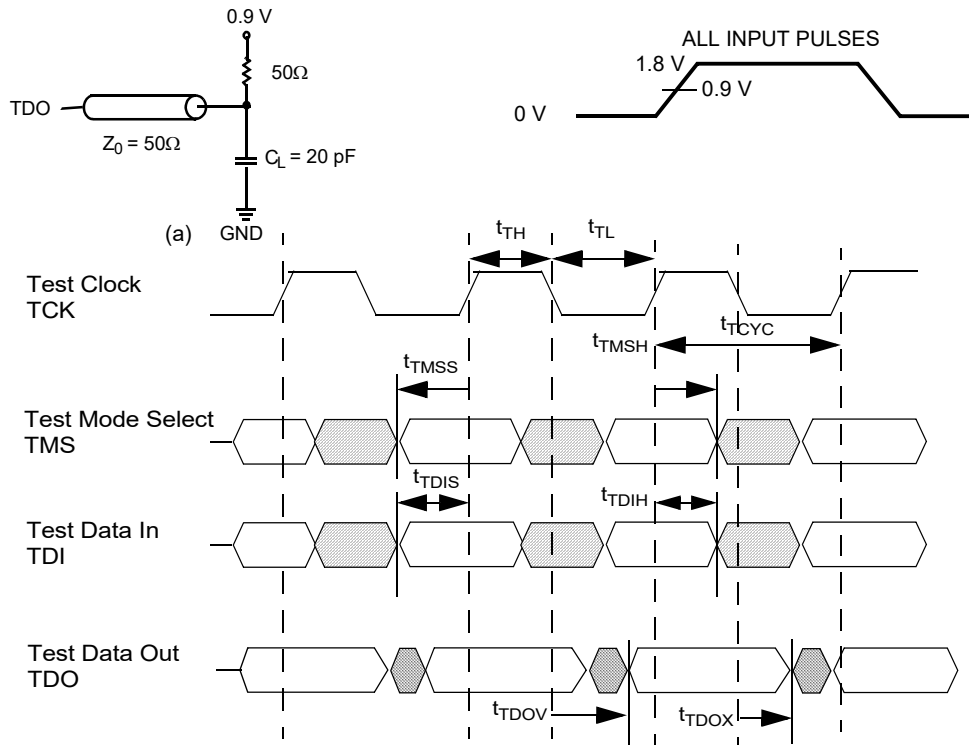

**Note**

19. Test conditions are specified using the load in TAP AC Test Conditions.  $t_R/t_F = 1$  ns.

### Identification Register Definitions

Instruction Field	Value		Description
	CYRS1543AV18	CYRS1545AV18	
Revision number (31:29)	000	000	Version number.
Cypress device ID (28:12)	11010010101010100	11010010101100100	Defines the type of SRAM.
Cypress JEDEC ID (11:1)	00000110100	00000110100	Allows unique identification of SRAM vendor.
ID register presence (0)	1	1	Indicates the presence of an ID register.

### Scan Register Sizes

Register Name	Bit Size
Instruction	3
Bypass	1
ID	32
Boundary scan	109

### Instruction Codes

Instruction	Code	Description
EXTEST	000	Captures the input and output ring contents.
IDCODE	001	Loads the ID register with the vendor ID code and places the register between TDI and TDO. This operation does not affect SRAM operation.
SAMPLE Z	010	Captures the input and output contents. Places the boundary scan register between TDI and TDO. Forces all SRAM output drivers to a high Z state.
RESERVED	011	Do Not Use: This instruction is reserved for future use.
SAMPLE/PRELOAD	100	Captures the input and output ring contents. Places the boundary scan register between TDI and TDO. Does not affect the SRAM operation.
RESERVED	101	Do Not Use: This instruction is reserved for future use.
RESERVED	110	Do Not Use: This instruction is reserved for future use.
BYPASS	111	Places the bypass register between TDI and TDO. This operation does not affect SRAM operation.

**Boundary Scan Order**

Bit #	Bump ID
0	6R
1	6P
2	6N
3	7P
4	7N
5	7R
6	8R
7	8P
8	9R
9	11P
10	10P
11	10N
12	9P
13	10M
14	11N
15	9M
16	9N
17	11L
18	11M
19	9L
20	10L
21	11 K
22	10K
23	9J
24	9K
25	10J
26	11J
27	11H

Bit #	Bump ID
28	10G
29	9G
30	11F
31	11G
32	9F
33	10F
34	11E
35	10E
36	10D
37	9E
38	10C
39	11D
40	9C
41	9D
42	11B
43	11C
44	9B
45	10B
46	11A
47	10A
48	9A
49	8B
50	7C
51	6C
52	8A
53	7A
54	7B
55	6B

Bit #	Bump ID
56	6A
57	5B
58	5A
59	4A
60	5C
61	4B
62	3A
63	2A
64	1A
65	2B
66	3B
67	1C
68	1B
69	3D
70	3C
71	1D
72	2C
73	3E
74	2D
75	2E
76	1E
77	2F
78	3F
79	1G
80	1F
81	3G
82	2G
83	1H

Bit #	Bump ID
84	1J
85	2J
86	3K
87	3J
88	2K
89	1K
90	2L
91	3L
92	1M
93	1L
94	3N
95	3M
96	1N
97	2M
98	3P
99	2N
100	2P
101	1P
102	3R
103	4R
104	4P
105	5P
106	5N
107	5R
108	Internal

## Power Up Sequence in QDR II+ SRAM

QDR II+ SRAMs must be powered up and initialized in a predefined manner to prevent undefined operations.

### Power Up Sequence

- Apply power and drive  $\overline{\text{DOFF}}$  either HIGH or LOW (All other inputs can be HIGH or LOW).
  - Apply  $V_{\text{DD}}$  before  $V_{\text{DDQ}}$ .
  - Apply  $V_{\text{DDQ}}$  before  $V_{\text{REF}}$  or at the same time as  $V_{\text{REF}}$ .
  - Drive  $\overline{\text{DOFF}}$  HIGH.
- Provide stable  $\overline{\text{DOFF}}$  (HIGH), power and clock ( $K, \overline{K}$ ) for 10240 cycles to lock the DLL.

### DLL Constraints

- DLL uses K clock as its synchronizing input. The input must have low phase jitter, which is specified as  $t_{\text{KC Var}}$ .
- The DLL functions at frequencies down to 120 MHz.
- If the input clock is unstable and the DLL is enabled, then the DLL may lock onto an incorrect frequency, causing unstable SRAM behavior. To avoid this, provide 10240 cycles stable clock to relock to the desired clock frequency.

Figure 4. Power Up Waveforms

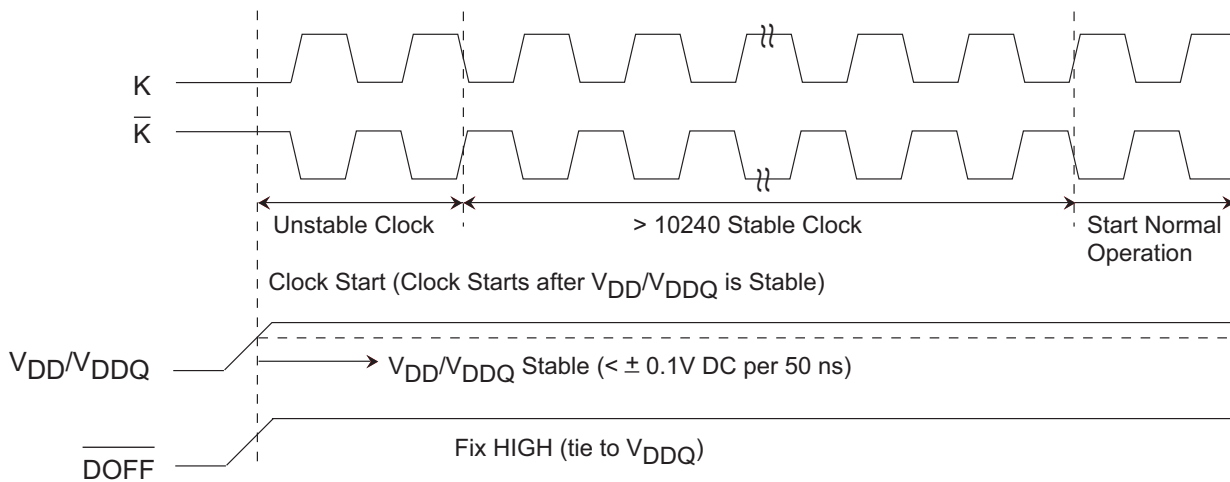

## Maximum Ratings

Exceeding maximum ratings may impair the useful life of the device. These user guidelines are not tested.

Storage temperature	-65 °C to +150 °C
Case temperature under power	-55 °C to +125 °C
Junction temperature under power	-55 °C to +155 °C
Supply voltage on V <sub>DD</sub> relative to GND	-0.5 V to +2.9 V
Supply voltage on V <sub>DDQ</sub> relative to GND	-0.5 V to +V <sub>DD</sub>
DC applied to outputs in high Z	-0.5 V to V <sub>DDQ</sub> + 0.3 V

DC input voltage <sup>[20]</sup>	-0.5 V to V <sub>DD</sub> + 0.3 V
Current into outputs (LOW)	20 mA
Static discharge voltage (MIL-STD-883, TM. 3015)	> 2001 V
Latch-up current	> 200 mA

## Operating Range

Range	Case Temperature (T <sub>c</sub> )	V <sub>DD</sub> <sup>[21]</sup>	V <sub>DDQ</sub> <sup>[21]</sup>
Military	-55 °C to +125 °C	1.8 ± 0.1 V	1.4 V to V <sub>DD</sub>

## Electrical Characteristics

Over the Operating Range

### DC Electrical Characteristics

Over the Operating Range

Parameter <sup>[22]</sup>	Description	Test Conditions	Min	Typ	Max	Unit	
V <sub>DD</sub>	Power supply voltage		1.7	1.8	1.9	V	
V <sub>DDQ</sub>	I/O supply voltage		1.4	1.5	V <sub>DD</sub>	V	
V <sub>OH</sub>	Output High voltage	Note 23	V <sub>DDQ</sub> /2 - 0.12	-	V <sub>DDQ</sub> /2 + 0.12	V	
V <sub>OL</sub>	Output Low voltage	Note 24	V <sub>DDQ</sub> /2 - 0.12	-	V <sub>DDQ</sub> /2 + 0.12	V	
V <sub>OH(LOW)</sub>	Output High voltage	I <sub>OH</sub> = -0.1 mA, nominal impedance	V <sub>DDQ</sub> - 0.2	-	V <sub>DDQ</sub>	V	
V <sub>OL(LOW)</sub>	Output Low voltage	I <sub>OL</sub> = 0.1 mA, nominal impedance	V <sub>SS</sub>	-	0.2	V	
V <sub>IH</sub>	Input High voltage		V <sub>REF</sub> + 0.1	-	V <sub>DDQ</sub> + 0.3	V	
V <sub>IL</sub>	Input Low voltage		-0.3	-	V <sub>REF</sub> - 0.1	V	
I <sub>X</sub>	Input leakage current	GND ≤ V <sub>I</sub> ≤ V <sub>DDQ</sub>	-20	-	20	μA	
I <sub>OZ</sub>	Output leakage current	GND ≤ V <sub>I</sub> ≤ V <sub>DDQ</sub> , output disabled	-20	-	20	μA	
V <sub>REF</sub>	Input reference voltage <sup>[25]</sup>	Typical Value = 0.75 V	0.68	0.75	0.95	V	
I <sub>DD</sub> <sup>[21]</sup>	V <sub>DD</sub> operating supply	V <sub>DD</sub> = Max, I <sub>OUT</sub> = 0 mA, T <sub>J</sub> = 125 °C f = f <sub>MAX</sub> = 1/t <sub>CYC</sub>					
		250 MHz	(× 18)	-	-	1275	mA
			(× 36)	-	-	1275	
I <sub>SB1</sub>	Automatic power down current	Max V <sub>DD</sub> , Both Ports Deselected, V <sub>IN</sub> ≥ V <sub>IH</sub> or V <sub>IN</sub> ≤ V <sub>IL</sub> , f = f <sub>MAX</sub> = 1/t <sub>CYC</sub> , T <sub>J</sub> = 125 °C, Inputs Static					
		250 MHz	(× 18)	-	-	570	mA
			(× 36)	-	-	570	

### Notes

- Overshoot: V<sub>IH(AC)</sub> < V<sub>DDQ</sub> + 0.85 V (Pulse width less than t<sub>CYC</sub>/2), Undershoot: V<sub>IL(AC)</sub> > -1.5 V (Pulse width less than t<sub>CYC</sub>/2).
- Power up: Assumes a linear ramp from 0 V to V<sub>DD(min)</sub> within 200 ms. During this time V<sub>IH</sub> < V<sub>DD</sub> and V<sub>DDQ</sub> ≤ V<sub>DD</sub>.
- All Voltage referenced to Ground.
- Output are impedance controlled. I<sub>OH</sub> = -(V<sub>DDQ</sub>/2)/(RQ/5) for values of 175 Ω ≤ RQ ≤ 350 Ω.
- Output are impedance controlled. I<sub>OL</sub> = (V<sub>DDQ</sub>/2)/(RQ/5) for values of 175 Ω ≤ RQ ≤ 350 Ω.
- V<sub>REF(min)</sub> = 0.68 V or 0.46 V<sub>DDQ</sub>, whichever is larger, V<sub>REF(max)</sub> = 0.95 V or 0.54 V<sub>DDQ</sub>, whichever is smaller.
- The operation current is calculated with concurrent read and write cycles.



## AC Electrical Characteristics

Over the Operating Range

Parameter <sup>[27, 28]</sup>	Description	Test Conditions	Min	Typ	Max	Unit
V <sub>IH</sub>	Input High voltage		V <sub>REF</sub> + 0.2	–	–	V
V <sub>IL</sub>	Input Low voltage		–	–	V <sub>REF</sub> – 0.2	V

## Radiation Performance

Parameter	Test Conditions	Limits	Unit
Total dose	T <sub>A</sub> = 25 °C, V <sub>DD</sub> = V <sub>DDQ</sub> = 1.8 V	300 Krad	Rads(Si) Co60
Soft error rate	T <sub>A</sub> = 25 °C to 125 °C, V <sub>DD</sub> = V <sub>DDQ</sub> = 1.8 V w/ EDAC	1.0 × 10 <sup>-10</sup>	Upsets/bit-day
Transient dose rate upset	Pulse Width (FWHM) = 50 ns, X-Ray, T <sub>C</sub> = 25 °C, V <sub>DD</sub> = V <sub>DDQ</sub> = 1.8 V	2.0 × 10 <sup>9</sup>	Rads(Si)/s
Neutron fluence	1 MeV equivalent energy, Unbiased T <sub>A</sub> = 25 °C	2e14	N/cm <sup>2</sup>
Latch up immunity	T <sub>A</sub> = 125 °C, V <sub>DD</sub> = V <sub>DDQ</sub> = 1.9 V	110	MeVcm <sup>2</sup> /mg

## Capacitance

Parameter <sup>[29]</sup>	Description	Test Conditions	Max	Unit
C <sub>IN</sub>	Input capacitance	T <sub>A</sub> = 25 °C, f = 1 MHz, V <sub>DD</sub> = 1.8 V, V <sub>DDQ</sub> = 1.5 V	10	pF
C <sub>CLK</sub>	Clock input capacitance		10	pF
C <sub>O</sub>	Output capacitance		10	pF

## Thermal Resistance

Parameter <sup>[29]</sup>	Description	Test Conditions	165-ball CCGA Package	Unit
Θ <sub>JC</sub>	Thermal resistance (junction to case)	Test conditions follow standard test methods and procedures for measuring thermal impedance, in accordance with EIA/JESD51.	8.9	°C/W

### Notes

27. Overshoot: V<sub>IH(AC)</sub> < V<sub>DDQ</sub> + 0.85 V (Pulse width less than t<sub>CYC/2</sub>), Undershoot: V<sub>IL(AC)</sub> > –1.5 V (Pulse width less than t<sub>CYC/2</sub>).  
 28. Power up: Assumes a linear ramp from 0 V to V<sub>DD(min)</sub> within 200 ms. During this time V<sub>IH</sub> < V<sub>DD</sub> and V<sub>DDQ</sub> ≤ V<sub>DD</sub>.  
 29. Tested initially and after any design or process change that may affect these parameters.

## AC Test Loads and Waveforms

Figure 5. AC Test Loads and Waveforms

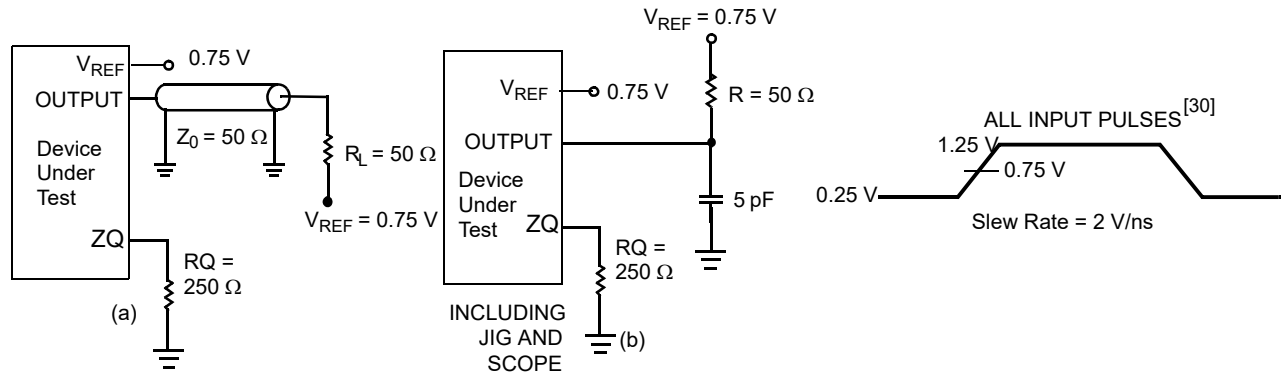

### Note

30. Unless otherwise noted, test conditions are based on signal transition time of  $2 \text{ V/ns}$ , timing reference levels of  $0.75 \text{ V}$ ,  $V_{ref} = 0.75 \text{ V}$ ,  $R_Q = 250 \Omega$ ,  $V_{DDQ} = 1.5 \text{ V}$ , input pulse levels of  $0.25 \text{ V}$  to  $1.25 \text{ V}$ , and output loading of the specified  $I_{OL}/I_{OH}$  and load capacitance shown in (a) of Figure 5.

## Switching Characteristics

Over the Operating Range

Parameters <sup>[31, 32]</sup>		Description	250 MHz		Unit
Cypress Parameter	Consortium Parameter		Min	Max	
t <sub>POWER</sub>		V <sub>DD</sub> (typical) to the first access <sup>[33]</sup>	1	–	ms
t <sub>CYC</sub>	t <sub>KHKH</sub>	K clock cycle time	4.0	8.4	ns
t <sub>KH</sub>	t <sub>KHKL</sub>	Input clock (K/ $\bar{K}$ ) HIGH	1.6	–	ns
t <sub>KL</sub>	t <sub>KLKH</sub>	Input clock (K/ $\bar{K}$ ) LOW	1.6	–	ns
t <sub>KH<math>\bar{K}</math>H</sub>	t <sub>KH<math>\bar{K}</math>H</sub>	K clock rise to $\bar{K}$ clock rise (rising edge to rising edge)	1.8	–	ns
<b>Setup Times</b>					
t <sub>SA</sub>	t <sub>AVKH</sub>	Address setup to K clock rise	0.5	–	ns
t <sub>SC</sub>	t <sub>IVKH</sub>	Control setup to K clock rise ( $\overline{RPS}$ , $\overline{WPS}$ )	0.5	–	ns
t <sub>SCDDR</sub>	t <sub>IVKH</sub>	DDR control setup to clock (K/ $\bar{K}$ ) rise ( $\overline{BWS}_0$ , $\overline{BWS}_1$ , $\overline{BWS}_2$ , $\overline{BWS}_3$ )	0.5	–	ns
t <sub>SD</sub> <sup>[34]</sup>	t <sub>DVKH</sub>	D <sub>[X:0]</sub> setup to clock (K/ $\bar{K}$ ) rise	0.5	–	ns
<b>Hold Times</b>					
t <sub>HA</sub>	t <sub>KHAX</sub>	Address hold after K clock rise	0.5	–	ns
t <sub>HC</sub>	t <sub>KHIX</sub>	Control hold after K clock rise ( $\overline{RPS}$ , $\overline{WPS}$ )	0.5	–	ns
t <sub>HCDDR</sub>	t <sub>KHIX</sub>	DDR control hold after clock (K/ $\bar{K}$ ) rise ( $\overline{BWS}_0$ , $\overline{BWS}_1$ , $\overline{BWS}_2$ , $\overline{BWS}_3$ )	0.5	–	ns
t <sub>HD</sub>	t <sub>KHDX</sub>	D <sub>[X:0]</sub> hold after clock (K/ $\bar{K}$ ) rise	0.5	–	ns
<b>Output Times</b>					
t <sub>CO</sub>	t <sub>CHQV</sub>	K/ $\bar{K}$ clock rise to data valid	–	0.85	ns
t <sub>DOH</sub>	t <sub>CHQX</sub>	Data output hold after output K/ $\bar{K}$ clock rise (Active to active)	–0.85	–	ns
t <sub>CCQO</sub>	t <sub>CHCQV</sub>	K/ $\bar{K}$ clock rise to echo clock valid	–	0.85	ns
t <sub>CQOH</sub>	t <sub>CHCQX</sub>	Echo clock hold after C/ $\bar{C}$ clock rise	–0.5	–	ns
t <sub>CQD</sub>	t <sub>CQHQV</sub>	Echo clock high to data valid	–	0.5	ns
t <sub>CQDOH</sub>	t <sub>CQHQX</sub>	Echo clock high to data invalid	–0.30	–	ns
t <sub>CQH</sub>	t <sub>CQH<math>\bar{C}</math>Q</sub>	Output clock (CQ/ $\bar{C}$ Q) HIGH <sup>[34]</sup>	1.55	–	ns
t <sub>CQH<math>\bar{C}</math>Q</sub>	t <sub>CQH<math>\bar{C}</math>Q</sub>	CQ clock rise to $\bar{C}$ Q clock rise (rising edge to rising edge) <sup>[34]</sup>	1.55	–	ns
t <sub>CHZ</sub>	t <sub>CHQZ</sub>	Clock (K/ $\bar{K}$ ) rise to high Z (Active to high Z) <sup>[35, 36]</sup>	–	0.45	ns
t <sub>CLZ</sub>	t <sub>CHQX1</sub>	Clock (K/ $\bar{K}$ ) rise to low Z <sup>[35, 36]</sup>	–0.45	–	ns
t <sub>QVLD</sub>	t <sub>CQH<math>\bar{C}</math>QVLD</sub>	Echo Clock High to QVLD Valid <sup>[37]</sup>	–0.5	0.5	ns
<b>DLL Timing</b>					
t <sub>KC Var</sub>	t <sub>KC Var</sub>	Clock phase jitter	–	0.2	ns
t <sub>KC lock</sub>	t <sub>KC lock</sub>	DLL lock time (K)	10240	–	Cycles
t <sub>KC Reset</sub>	t <sub>KC Reset</sub>	K static to DLL reset	30	–	ns

### Notes

31. Unless otherwise noted, test conditions are based on signal transition time of 2 V/ns, timing reference levels of 0.75 V, V<sub>ref</sub> = 0.75 V, R<sub>Q</sub> = 250 Ω, V<sub>DDQ</sub> = 1.5 V, input pulse levels of 0.25 V to 1.25 V, and output loading of the specified I<sub>OL</sub>/I<sub>OH</sub> and load capacitance shown in (a) of Figure 5 on page 24.
32. When a part with a maximum frequency above 167 MHz is operating at a lower clock frequency, it requires the input timings of the frequency range in which it is being operated and outputs data with the output timings of that frequency range.
33. This part has a voltage regulator internally; t<sub>POWER</sub> is the time that the power must be supplied above V<sub>DD(minimum)</sub> initially before a read or write operation can be initiated.
34. These parameters are extrapolated from the input timing parameters (t<sub>KH $\bar{K}$ H</sub> – 250 ps, where 250 ps is the internal jitter. An input jitter of 200 ps (t<sub>KC Var</sub>) is already included in the t<sub>KH $\bar{K}$ H</sub>). These parameters are only guaranteed by design and are not tested in production.
35. t<sub>CHZ</sub>, t<sub>CLZ</sub>, are specified with a load capacitance of 5 pF as in (b) of Figure 5 on page 24. Transition is measured ± 100 mV from steady-state voltage.
36. At any voltage and temperature t<sub>CHZ</sub> is less than t<sub>CLZ</sub> and t<sub>CHZ</sub> less than t<sub>CO</sub>.
37. t<sub>QVLD</sub> Spec is applicable for both rising and falling edges of QVLD signal.

## Switching Waveforms

Figure 6. Read/Write/Deselect Sequence [38, 39, 40]

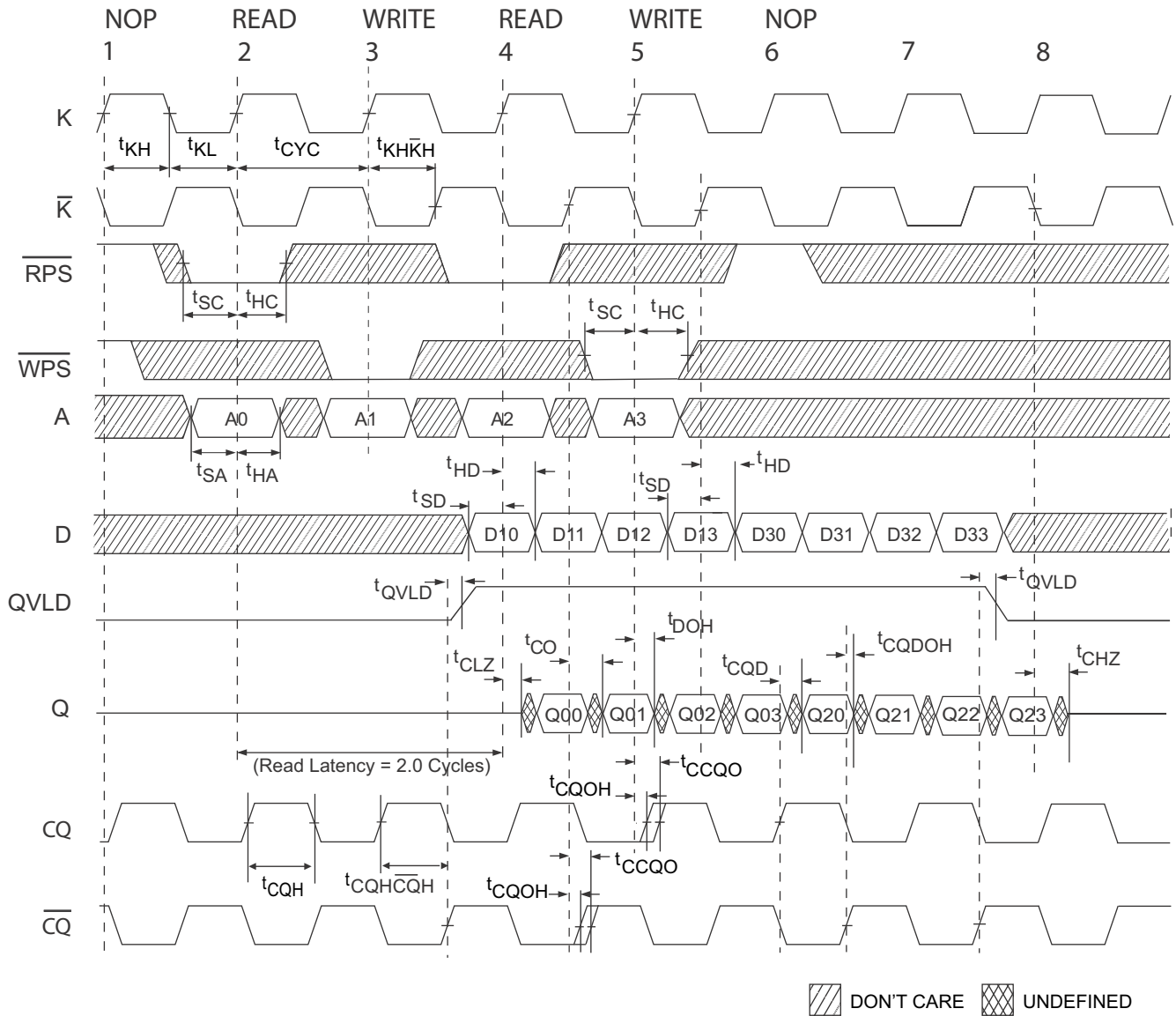

### Notes

38. Q00 refers to output from address A0. Q01 refers to output from the next internal burst address following A0, that is, A0 + 1.

39. Outputs are disabled (high Z) one clock cycle after a NOP.

40. In this example, if address A2 = A1, then data Q20 = D10, Q21 = D11, Q22 = D12, and Q23 = D13. Write data is forwarded immediately as read results. This note applies to Figure 6.

## Ordering Information

The following table contains only the parts that are currently available. If you do not see what you are looking for (× 18 option), contact your local sales representative. For more information, visit the Cypress website at [www.cypress.com](http://www.cypress.com) and refer to the product summary page at <http://www.cypress.com/products>.

Cypress maintains a worldwide network of offices, solution centers, manufacturer's representatives and distributors. To find the office closest to you, visit us at <http://www.cypress.com/go/datasheet/offices>.

Speed (MHz)	Ordering Code	Description	Package Diagram	Package Type	Operating Range
250	CYRS1543AV18-250GCMB	72M QDR II+, × 18, Burst of 4	001-58969	165-ball CCGA (21 × 25 × 2.83 mm)	Military
250	CYRS1545AV18-250GCMB	72M QDR II+, × 36, Burst of 4	001-58969	165-ball CCGA (21 × 25 × 2.83 mm)	Military
250	CYPT1543AV18-250GCMB	72M QDR II+, × 18, Burst of 4, Prototype	001-58969	165-ball CCGA (21 × 25 × 2.83 mm)	Military
250	CYPT1545AV18-250GCMB	72M QDR II+, × 36, Burst of 4, Prototype	001-58969	165-ball CCGA (21 × 25 × 2.83 mm)	Military
250	CYPT1543AV18-250GLMB	72M QDR II+, × 18, Burst of 4, Prototype	002-21565	165-ball CLGA w/o solder columns (21 × 25 × 3.07 mm)	Military
250	CYPT1545AV18-250GLMB	72M QDR II+, × 36, Burst of 4, Prototype	002-21565	165-ball CLGA w/o solder columns (21 × 25 × 3.07 mm)	Military
250	5962F1120102VXA	72M QDR II+, × 18, Burst of 4, DLAM Part	001-58969	165-ball CCGA (21 × 25 × 2.83 mm)	Military
250	5962F1120202VXA	72M QDR II+, × 36, Burst of 4, DLAM Part	001-58969	165-ball CCGA (21 × 25 × 2.83 mm)	Military

## Ordering Code Definitions

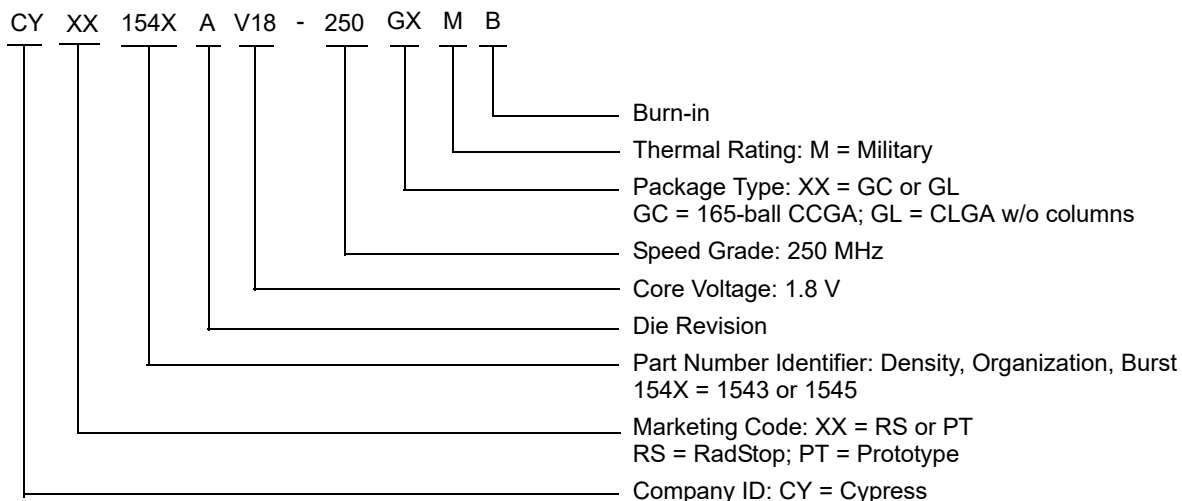

### Package Diagrams

Figure 7. 165-ball Ceramic Column Grid Array (CCGA) (21 × 25 mm) Package Outline, 001-58969

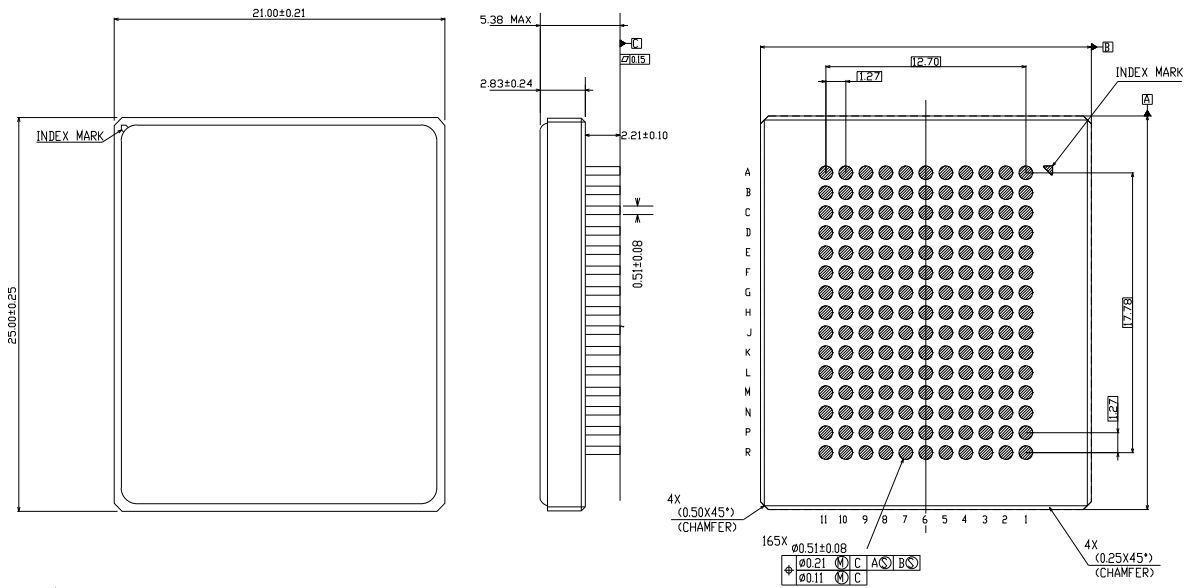

NOTES:

1. JEDEC REFERENCE : MQ-158 VAR BE-1
2. ALL DIMENSIONS ARE IN MILLIMETERS

001-58969 \*E

**Figure 8. 165-ball Ceramic Land Grid Array (LGA) (21 × 25 × 3.07 mm) Package Outline, 002-21565**

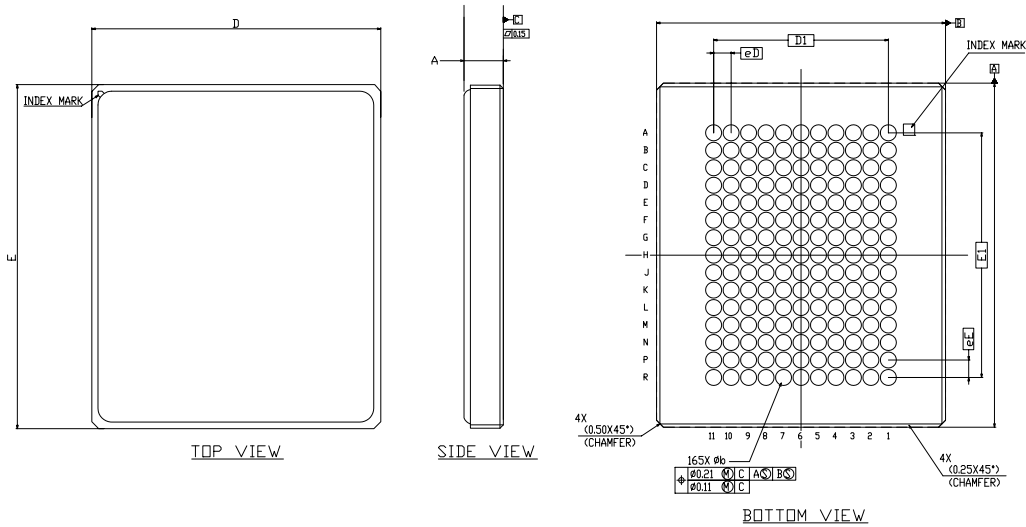

SYMBOL	DIMENSIONS		
	MIN.	NOM.	MAX.
A	2.59	2.83	3.07
D	20.79	21.00	21.21
E	24.75	25.00	25.25
D1	12.70 BSC		
E1	17.78 BSC		
N	165		
$\varnothing b$	1.08	1.16	1.24
eD	1.27 BSC		
eE	1.27 BSC		

NOTES:  
 1. ALL DIMENSIONS ARE IN MILLIMETERS.

002-21565 \*\*



## Acronyms

Acronym	Description
BWS	byte write select
CCGA	ceramic column grid array
DED	double error detection
DLL	delay lock loop
DDR	double data rate
DSCC	defense supply center columbus
EDAC	error detection and correction
HSTL	high speed transceiver logic
I/O	input/output
JTAG	Joint Test Action Group
LSB	least significant bit
LSBU	logical single-bit upsets
LMBU	logical multi-bit upsets
MSB	most significant bit
PDA	percent defect allowable
PIND	particle impact noise detection
PDA	percent defective allowable
QDR	quad data rate
RPS	read port select
SEC	single error correction
SEL	single event latch up
SRAM	static random access memory
TAP	test access port
TCK	test clock
TDI	test data in
TDO	test data out
TMS	test mode select
WPS	write port select

## Document Conventions

### Units of Measure

Symbol	Unit of Measure
°C	degree Celsius
Krad	kiloradian
MHz	megahertz
μA	microampere
μF	microfarad
μs	microsecond
mA	milliamperere
mm	millimeter
ms	millisecond
mV	millivolt
N/cm <sup>2</sup>	Neutron particles fluence per cm <sup>2</sup> area
ns	nanosecond
nm	nanometer
Ω	ohm
%	percent
pF	picofarad
ps	picosecond
Rads(Si)	unit of absorbed radiation energy from ionizing radiation per kg of material. (1 rad(Si)) = 10 mGy = 10 <sup>-2</sup> J/kg
V	volt
W	watt

## Glossary

<b>Total Dose</b>	Permanent device damage due to ions over device life
<b>Heavy Ion</b>	Instantaneous device latch up due to single ion
<b>LET</b>	Linear energy transfer (measured in MeVcm <sup>2</sup> )
<b>Krad</b>	Unit of measurement to determine device life in radiation environments.
<b>Neutron</b>	Permanent device damage due to energetic neutrons or protons
<b>Prompt Dose</b>	Data loss of permanent device damage due to X-rays and gamma rays < 20 ns
<b>165-ball Ceramic Column Grid Array</b>	Hermetic ceramic 165-column package. Columns attached by Six Sigma
<b>RadStop Technology</b>	Cypress's patented Rad Hard design methodology
<b>DLAM</b>	Defense Logistics Agency Land and Maritime
<b>LSBU</b>	Logical Single Bit Upset. Single bits in a single correction word are in error.
<b>LMBU</b>	Logical Multi Bit Upset. Multiple bits in a single correction word are in error.
<b>Group A</b>	General electrical testing
<b>Group B</b>	Mechanical - Dimensions, bond strength, solvents, die shear, solderability, lead integrity, seal, acceleration
<b>Group C</b>	Life test - 1000 hours at 125 °C
<b>Group D</b>	Package related mechanical tests - shock, vibration, Accel, salt, seal, lead finish adhesion, lid torque, thermal shock, moisture resistance
<b>Group E</b>	Radiation testing

## Document History Page

Document Title: CYRS1543AV18/CYRS1545AV18, 72-Mbit QDR® II+ SRAM Four-Word Burst Architecture with RadStop™ Technology				
Document Number: 001-60007				
Rev.	ECN No.	Orig. of Change	Submission Date	Description of Change
**	2940931	HRP	05/31/2010	New data sheet.
*A	3016545	HRP	08/26/2010	Changed part numbers from CYRS1513AV18, CYRS1515AV18 to reflect change to QDR II+ die. Updated <a href="#">Switching Characteristics</a> (Updated minimum and maximum values for Setup Time, Hold Time parameters, and updated minimum and maximum values for t <sub>CO</sub> parameter under Output Time parameter). Updated <a href="#">Package Diagrams</a> : spec 001-58969 – Changed revision from ** to *A. Added <a href="#">Units of Measure</a> .
*B	3281455	HRP	06/13/2011	Changed status from Advanced to Final. Replaced 2048 with 10240 for DLL lockup cycles in all instances across the document. Updated <a href="#">Configurations</a> (corrected typo). Updated <a href="#">Selection Guide</a> . Updated <a href="#">DC Electrical Characteristics</a> (maximum current limit values for the parameters IDD and ISB1 based on device characterization). Updated <a href="#">Radiation Performance</a> (Limits of Radiation Data based on RHA qualification). Updated <a href="#">Thermal Resistance</a> . Updated <a href="#">Switching Characteristics</a> (Minimum and Maximum timing values for the parameters t <sub>CO</sub> , t <sub>DOH</sub> , t <sub>CCQO</sub> , t <sub>CCQH</sub> based on device characterization). Updated <a href="#">Ordering Information</a> (Removed × 18 option from ordering table). Updated <a href="#">Package Diagrams</a> : spec 001-58969 – Changed revision from *A to *C. Updated to new template.
*C	3471321	HRP	12/21/2011	Updated <a href="#">Identification Register Definitions</a> (Replaced the value of Cypress device ID (28:12) from 11010011011010100 to 11010010101010100 for CYRS1543AV18 and replaced the value of Cypress device ID (28:12) from 11010011011100100 to 11010010101100100 for CYRS1545AV18).
*D	3524961	HRP	02/14/2012	Updated <a href="#">Prototyping Options</a> under <a href="#">Radiation Performance</a> (Added two devices). Updated <a href="#">Selection Guide</a> (Removed 200 MHz option). Updated <a href="#">Application Example</a> . Updated <a href="#">Truth Table</a> . Updated <a href="#">Maximum Ratings</a> . Updated <a href="#">Operating Range</a> . Updated <a href="#">Radiation Performance</a> . Updated <a href="#">Capacitance</a> . Updated <a href="#">Thermal Resistance</a> . Updated <a href="#">Switching Characteristics</a> .
*E	3537277	HRP	02/29/2012	Updated <a href="#">Radiation Data</a> under <a href="#">Radiation Performance</a> . Updated <a href="#">Ordering Information</a> (Updated part numbers).
*F	3617759	HRP	05/15/2012	Updated <a href="#">Ordering Information</a> (Updated part numbers). Updated <a href="#">Glossary</a> . Completing Sunset Review.
*G	3640834	HRP	06/08/2012	Updated <a href="#">Radiation Performance</a> (Updated <a href="#">Prototyping Options</a> ). Renamed the section Class V Flow as <a href="#">Manufacturing Flow</a> . Updated <a href="#">Glossary</a> .
*H	3857750	HRP	01/04/2013	Updated <a href="#">Ordering Information</a> (Updated part numbers).

**Document History Page** (continued)

Document Title: CYRS1543AV18/CYRS1545AV18, 72-Mbit QDR <sup>®</sup> II+ SRAM Four-Word Burst Architecture with RadStop <sup>™</sup> Technology Document Number: 001-60007				
Rev.	ECN No.	Orig. of Change	Submission Date	Description of Change
*I	3900846	HRP	02/11/2013	Updated <a href="#">Neutron Soft Error Immunity</a> (Changed value of Test Conditions of SEL parameter from 85 °C to 125 °C). Updated <a href="#">Pin Definitions</a> (Changed Pin Name from A to A <sub>[x:0]</sub> ). Updated <a href="#">Functional Overview</a> (Updated <a href="#">Qualification and Screening</a> (Replaced Class V with Class Q)). Updated <a href="#">Application Example</a> (Replaced four with two).
*J	3934155	MISA	03/15/2013	Updated <a href="#">Selection Guide</a> : Changed Maximum operating current (125 °C, concurrent R/W) corresponding to “x 18” for 250 MHz frequency from 1225 mA to 1275 mA. Changed Maximum operating current (125 °C, concurrent R/W) corresponding to “x 36” for 250 MHz frequency from 1225 mA to 1275 mA. Updated <a href="#">Electrical Characteristics</a> : Updated <a href="#">DC Electrical Characteristics</a> : Changed maximum value of I <sub>DD</sub> parameter corresponding to “x 18” for 250 MHz frequency from 1225 mA to 1275 mA. Changed maximum value of I <sub>DD</sub> parameter corresponding to “x 36” for 250 MHz frequency from 1225 mA to 1275 mA. Changed maximum value of I <sub>SB1</sub> parameter corresponding to “x 18” for 250 MHz frequency from 510 mA to 570 mA. Changed maximum value of I <sub>SB1</sub> parameter corresponding to “x 36” for 250 MHz frequency from 510 mA to 570 mA. Removed 200 MHz frequency related information. Updated <a href="#">Switching Characteristics</a> : Changed maximum value of t <sub>CO</sub> and t <sub>CHQV</sub> parameters from 0.7 ns to 0.85 ns. Changed minimum value of t <sub>DOH</sub> and t <sub>CHQX</sub> parameters from –0.7 ns to –0.85 ns. Changed maximum value of t <sub>CCQO</sub> and t <sub>CHCQV</sub> parameters from 0.7 ns to 0.85 ns. Changed minimum value of t <sub>CQOH</sub> and t <sub>CHCQX</sub> parameters from –0.7 ns to –0.5 ns. Removed 200 MHz frequency related information. Updated <a href="#">Package Diagrams</a> : spec 001-58969 – Changed revision from *C to *D.
*K	4286754	MISA	02/21/2014	Updated <a href="#">Functional Overview</a> : Updated <a href="#">Qualification and Screening</a> : Replaced “Class Q” with “Class Q, Class V”. Updated <a href="#">Ordering Information</a> (Updated part numbers). Updated to new template.
*L	4618500	PRIT	01/09/2015	Updated <a href="#">Radiation Performance</a> : Updated <a href="#">Radiation Data</a> : Updated 2 <sup>nd</sup> bulleted point. Updated <a href="#">Functional Description</a> : Added “For a complete list of related resources, <a href="#">click here</a> .” at the end. Updated <a href="#">Pin Definitions</a> : Updated description of CQ and $\overline{CQ}$ pins. Updated <a href="#">Functional Overview</a> : Updated description. Updated <a href="#">Read Operations</a> : Updated description. Updated <a href="#">Write Operations</a> : Updated description. Updated <a href="#">Application Example</a> : Updated <a href="#">Figure 2</a> .

**Document History Page** (continued)

Document Title: CYRS1543AV18/CYRS1545AV18, 72-Mbit QDR <sup>®</sup> II+ SRAM Four-Word Burst Architecture with RadStop <sup>™</sup> Technology Document Number: 001-60007				
Rev.	ECN No.	Orig. of Change	Submission Date	Description of Change
*M	5956093	HRP	11/03/2017	Added 165-ball Ceramic Land Grid Array Package related information in all instances across the document. Updated <a href="#">Ordering Information</a> : Updated part numbers. Updated <a href="#">Package Diagrams</a> : spec 001-58969 – Changed revision from *D to *E. Added spec 002-21565 Rev. **. ** Updated to new template. Completing Sunset Review.

## Sales, Solutions, and Legal Information

### Worldwide Sales and Design Support

Cypress maintains a worldwide network of offices, solution centers, manufacturers' representatives, and distributors. To find the office closest to you, visit us at [Cypress Locations](#).

#### Products

ARM <sup>®</sup> Cortex <sup>®</sup> Microcontrollers	<a href="http://cypress.com/arm">cypress.com/arm</a>
Automotive	<a href="http://cypress.com/automotive">cypress.com/automotive</a>
Clocks & Buffers	<a href="http://cypress.com/clocks">cypress.com/clocks</a>
Interface	<a href="http://cypress.com/interface">cypress.com/interface</a>
Internet of Things	<a href="http://cypress.com/iot">cypress.com/iot</a>
Memory	<a href="http://cypress.com/memory">cypress.com/memory</a>
Microcontrollers	<a href="http://cypress.com/mcu">cypress.com/mcu</a>
PSoC	<a href="http://cypress.com/psoc">cypress.com/psoc</a>
Power Management ICs	<a href="http://cypress.com/pmic">cypress.com/pmic</a>
Touch Sensing	<a href="http://cypress.com/touch">cypress.com/touch</a>
USB Controllers	<a href="http://cypress.com/usb">cypress.com/usb</a>
Wireless Connectivity	<a href="http://cypress.com/wireless">cypress.com/wireless</a>

#### PSoC<sup>®</sup> Solutions

[PSoC 1](#) | [PSoC 3](#) | [PSoC 4](#) | [PSoC 5LP](#) | [PSoC 6](#)

#### Cypress Developer Community

[Forums](#) | [WICED IOT Forums](#) | [Projects](#) | [Video](#) | [Blogs](#) | [Training](#) | [Components](#)

#### Technical Support

[cypress.com/support](http://cypress.com/support)

---

© Cypress Semiconductor Corporation, 2010–2017. This document is the property of Cypress Semiconductor Corporation and its subsidiaries, including Spansion LLC ("Cypress"). This document, including any software or firmware included or referenced in this document ("Software"), is owned by Cypress under the intellectual property laws and treaties of the United States and other countries worldwide. Cypress reserves all rights under such laws and treaties and does not, except as specifically stated in this paragraph, grant any license under its patents, copyrights, trademarks, or other intellectual property rights. If the Software is not accompanied by a license agreement and you do not otherwise have a written agreement with Cypress governing the use of the Software, then Cypress hereby grants you a personal, non-exclusive, nontransferable license (without the right to sublicense) (1) under its copyright rights in the Software (a) for Software provided in source code form, to modify and reproduce the Software solely for use with Cypress hardware products, only internally within your organization, and (b) to distribute the Software in binary code form externally to end users (either directly or indirectly through resellers and distributors), solely for use on Cypress hardware product units, and (2) under those claims of Cypress's patents that are infringed by the Software (as provided by Cypress, unmodified) to make, use, distribute, and import the Software solely for use with Cypress hardware products. Any other use, reproduction, modification, translation, or compilation of the Software is prohibited.

TO THE EXTENT PERMITTED BY APPLICABLE LAW, CYPRESS MAKES NO WARRANTY OF ANY KIND, EXPRESS OR IMPLIED, WITH REGARD TO THIS DOCUMENT OR ANY SOFTWARE OR ACCOMPANYING HARDWARE, INCLUDING, BUT NOT LIMITED TO, THE IMPLIED WARRANTIES OF MERCHANTABILITY AND FITNESS FOR A PARTICULAR PURPOSE. To the extent permitted by applicable law, Cypress reserves the right to make changes to this document without further notice. Cypress does not assume any liability arising out of the application or use of any product or circuit described in this document. Any information provided in this document, including any sample design information or programming code, is provided only for reference purposes. It is the responsibility of the user of this document to properly design, program, and test the functionality and safety of any application made of this information and any resulting product. Cypress products are not designed, intended, or authorized for use as critical components in systems designed or intended for the operation of weapons, weapons systems, nuclear installations, life-support devices or systems, other medical devices or systems (including resuscitation equipment and surgical implants), pollution control or hazardous substances management, or other uses where the failure of the device or system could cause personal injury, death, or property damage ("Unintended Uses"). A critical component is any component of a device or system whose failure to perform can be reasonably expected to cause the failure of the device or system, or to affect its safety or effectiveness. Cypress is not liable, in whole or in part, and you shall and hereby do release Cypress from any claim, damage, or other liability arising from or related to all Unintended Uses of Cypress products. You shall indemnify and hold Cypress harmless from and against all claims, costs, damages, and other liabilities, including claims for personal injury or death, arising from or related to any Unintended Uses of Cypress products.

Cypress, the Cypress logo, Spansion, the Spansion logo, and combinations thereof, WICED, PSoC, CapSense, EZ-USB, F-RAM, and Traveo are trademarks or registered trademarks of Cypress in the United States and other countries. For a more complete list of Cypress trademarks, visit [cypress.com](http://cypress.com). Other names and brands may be claimed as property of their respective owners.

Компания «Океан Электроники» предлагает заключение долгосрочных отношений при поставках импортных электронных компонентов на взаимовыгодных условиях!

Наши преимущества:

- Поставка оригинальных импортных электронных компонентов напрямую с производств Америки, Европы и Азии, а так же с крупнейших складов мира;
- Широкая линейка поставок активных и пассивных импортных электронных компонентов (более 30 млн. наименований);
- Поставка сложных, дефицитных, либо снятых с производства позиций;
- Оперативные сроки поставки под заказ (от 5 рабочих дней);
- Экспресс доставка в любую точку России;
- Помощь Конструкторского Отдела и консультации квалифицированных инженеров;
- Техническая поддержка проекта, помощь в подборе аналогов, поставка прототипов;
- Поставка электронных компонентов под контролем ВП;
- Система менеджмента качества сертифицирована по Международному стандарту ISO 9001;
- При необходимости вся продукция военного и аэрокосмического назначения проходит испытания и сертификацию в лаборатории (по согласованию с заказчиком);
- Поставка специализированных компонентов военного и аэрокосмического уровня качества (Xilinx, Altera, Analog Devices, Intersil, Interpoint, Microsemi, Actel, Aeroflex, Peregrine, VPT, Syfer, Eurofarad, Texas Instruments, MS Kennedy, Miteq, Cobham, E2V, MA-COM, Hittite, Mini-Circuits, General Dynamics и др.);

Компания «Океан Электроники» является официальным дистрибьютором и эксклюзивным представителем в России одного из крупнейших производителей разъемов военного и аэрокосмического назначения «JONHON», а так же официальным дистрибьютором и эксклюзивным представителем в России производителя высокотехнологичных и надежных решений для передачи СВЧ сигналов «FORSTAR».



## JONHON

«JONHON» (основан в 1970 г.)

Разъемы специального, военного и аэрокосмического назначения:

(Применяются в военной, авиационной, аэрокосмической, морской, железнодорожной, горно- и нефтедобывающей отраслях промышленности)

«FORSTAR» (основан в 1998 г.)

ВЧ соединители, коаксиальные кабели,  
кабельные сборки и микроволновые компоненты:

(Применяются в телекоммуникациях гражданского и специального назначения, в средствах связи, РЛС, а так же военной, авиационной и аэрокосмической отраслях промышленности).



Телефон: 8 (812) 309-75-97 (многоканальный)

Факс: 8 (812) 320-03-32

Электронная почта: [ocean@oceanchips.ru](mailto:ocean@oceanchips.ru)

Web: <http://oceanchips.ru/>

Адрес: 198099, г. Санкт-Петербург, ул. Калинина, д. 2, корп. 4, лит. А