

DESCRIPTION

The MP1528 is a step-up converter designed for driving up to nine (9) series White LEDs (LED) from a single cell Lithium-Ion battery. It regulates the LED current and includes an analog input for varying the LED brightness.

The MP1528 uses current limited, variable frequency architecture to regulate the LED current while maintaining high efficiency. The BIAS pin measures the output voltage and turns off the converter if an over voltage condition is present to prevent damage due to an open circuit condition. The LED current is measured with an external current sense resistor. The low 0.4V full-scale regulation threshold and 0.63Ω power switch minimize power loss.

The MP1528 is available in an 8-pin MSOP, an 8-pin 2mm x 2mm QFN and a 6-pin 3mm x 3mm QFN packages.

EVALUATION BOARD REFERENCE

Board Number	Dimensions
EV1528DQ-00A	2.0" x 1.5" x 0.5"

FEATURES

- Drives up to 9 Series White LEDs
- Integrated 0.63Ω Power MOSFET
- Low 0.4V Full-Scale Current Sense Threshold
- Over 20mA Output Current Capacity
- Analog and Digital PWM Brightness Control
- Open Load Shutdown
- Soft-Start
- Internal Current Limit
- Under Voltage Lockout
- Thermal Shutdown
- Available in 8-Pin MSOP, 8-pin 2mm x 2mm QFN and 6-Pin 3mm x 3mm QFN Packages

APPLICATIONS

- Handheld Computers
- PDAs
- PDA Phones
- Digital and Video Cameras
- Small LCD Displays

"MPS" and "The Future of Analog IC Technology" are Registered Trademarks of Monolithic Power Systems, Inc.

TYPICAL APPLICATION

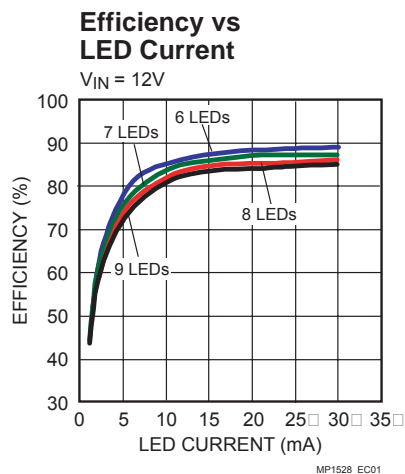
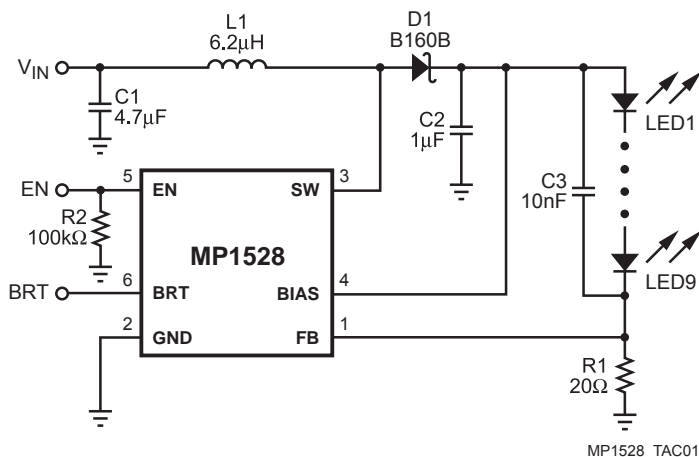

ORDERING INFORMATION

Part Number*	Package	Top Marking	Temperature
MP1528DQ	QFN6 (3mm x 3mm)	A6YW	–40°C to +85°C
Part Number**	Package	Top Marking	Temperature
MP1528DK	MSOP8	1528D	–40°C to +85°C
Part Number***	Package	Top Marking	Temperature
MP1528DG	QFN8 (2mm x 2mm)	A6Y	–40°C to +85°C

*For Tape & Reel, add suffix –Z (e.g. MP1528DQ–Z). For RoHS compliant packaging, add suffix –LF (e.g. MP1528DQ–LF–Z)

**For Tape & Reel, add suffix –Z (e.g. MP1528DK–Z). For RoHS compliant packaging, add suffix –LF (e.g. MP1528DK–LF–Z)

***For Tape & Reel, add suffix –Z (e.g. MP1528DG–Z). For RoHS compliant packaging, add suffix –LF (e.g. MP1528DG–LF–Z)

PACKAGE REFERENCE

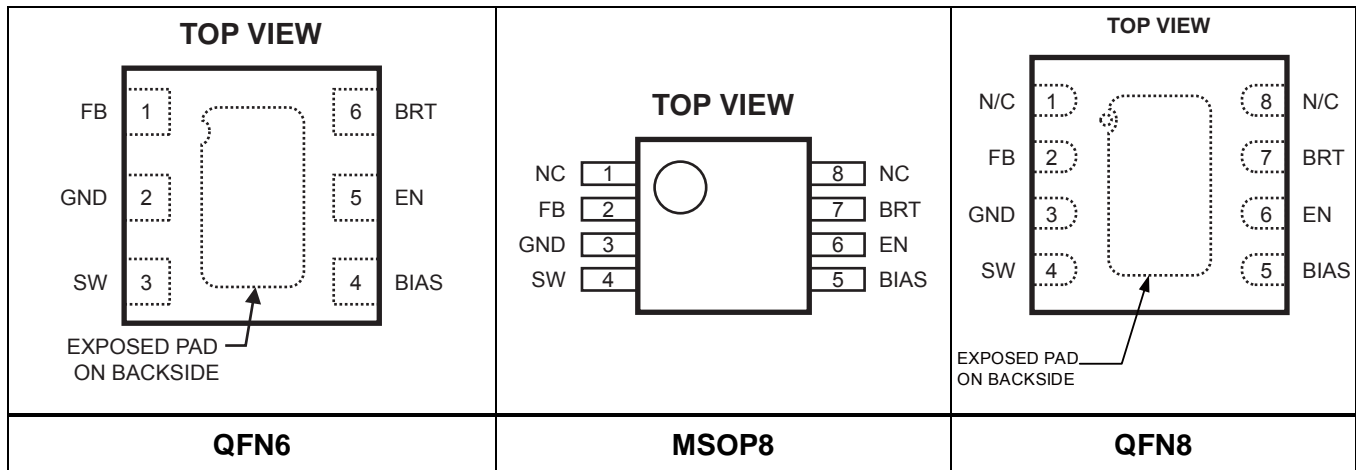

ABSOLUTE MAXIMUM RATINGS ⁽¹⁾

Supply Voltage V_{BIAS} to GND	42V
V_{SW} to GND	–0.5V to +42V
V_{EN} , V_{BRT} , V_{FB} to GND	–0.3V to +6V
Continuous Power Dissipation $(T_A = +25^\circ\text{C})^{(2)}$	
QFN6 (3mm x 3mm)	2.5W
QFN8 (2mm x 2mm)	1.6W
MSOP8	0.83W
Storage Temperature	–65°C to +150°C

Recommended Operating Conditions ⁽³⁾

Supply Voltage V_{BIAS}	2.7V to 36V
Operating Temperature	–40°C to +85°C

<i>Thermal Resistance</i> ⁽⁴⁾	θ_{JA}	θ_{JC}
QFN6 (3mm x 3mm)	50	14... °C/W
QFN8 (2mm x 2mm)	80	16... °C/W
MSOP8	150	65... °C/W

Notes:

- 1) Exceeding these ratings may damage the device.
- 2) The maximum allowable power dissipation is a function of the maximum junction temperature $T_J(\text{MAX})$, the junction-to-ambient thermal resistance θ_{JA} , and the ambient temperature T_A . The maximum allowable continuous power dissipation at any ambient temperature is calculated by $P_D(\text{MAX}) = (T_J(\text{MAX}) - T_A) / \theta_{JA}$. Exceeding the maximum allowable power dissipation will cause excessive die temperature, and the regulator will go into thermal shutdown. Internal thermal shutdown circuitry protects the device from permanent damage.
- 3) The device is not guaranteed to function outside of its operating conditions.
- 4) Measured on JESD51-7 4-layer board.

ELECTRICAL CHARACTERISTICS

$V_{BIAS} = V_{EN} = 5.0V$, $V_{BRT} = 1.2V$, $T_A = +25^{\circ}C$, unless otherwise noted.

Parameter	Symbol	Condition	Min	Typ	Max	Units
Supply Current (Shutdown)		$V_{EN} < 0.4V$		1	3	μA
Supply Current (Quiescent)		$V_{EN} > 2.0V$, BRT = GND		650	800	μA
Minimum Off Time (Normal Operation)				330		ns
Minimum Off Time (Startup)				1.2		μs
Under Voltage Lock Out						
BIAS Under Voltage Lock Out	UVLO	V_{BIAS} Rising, 100mV Hysteresis	2.1		2.65	V
Enable						
EN High Threshold			0.8	1.2	1.5	V
EN Hysteresis				60		mV
EN Input Leakage Current					150	nA
Open Load Shutdown						
Threshold		Measured at BIAS		40		V
Bias Current		$V_{BIAS} = 20V$, $V_{EN} < 0.4V$			5	μA
		$V_{BIAS} = 40V$, $V_{EN} < 0.4V$		70	100	μA
Feedback Comparator						
FB Regulation Threshold	V_{FB}	$V_{BRT} = 1.2V$	0.38	0.40	0.42	V
FB Hysteresis				10		mV
FB Input Leakage Current		$V_{FB} = 0.2V$	-150	-80		nA
PWM Mode Using BRT						
Output-Off Threshold			0.18		0.27	V
BRT Input Leakage Current		$V_{BRT} = 0.6V$	-100			nA
BRT Full-Scale Threshold					1.2	V
Output Switch						
SW On-Resistance	R_{ON}	$V_{BIAS} = 5.0V$		0.63		Ω
SW Current Limit				950		mA
Thermal Shutdown				160		$^{\circ}C$

TYPICAL PERFORMANCE CHARACTERISTICS

Circuit on front page, $V_{IN} = 3.6V$, 9 LEDs, $I_{LED} = 20mA$, $V_{BRT} = 1.2V$, $T_A = +25^\circ C$, unless otherwise noted.

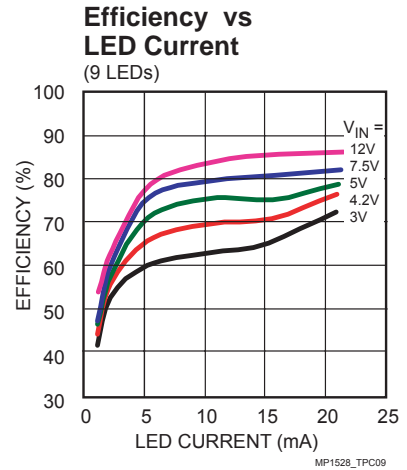
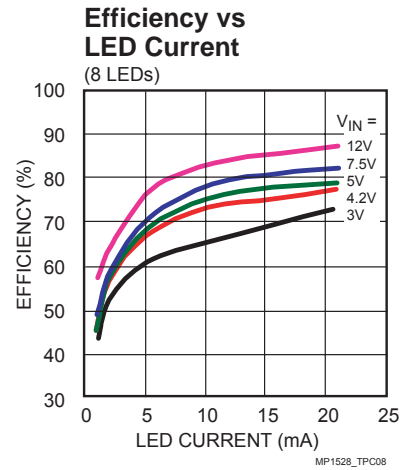
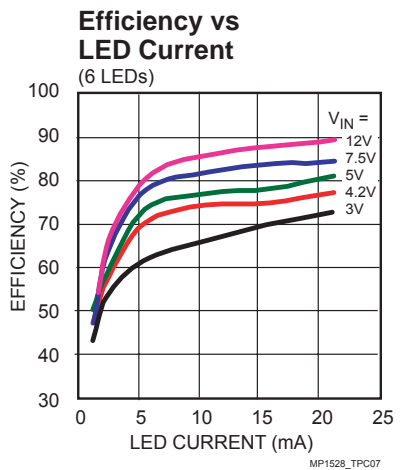
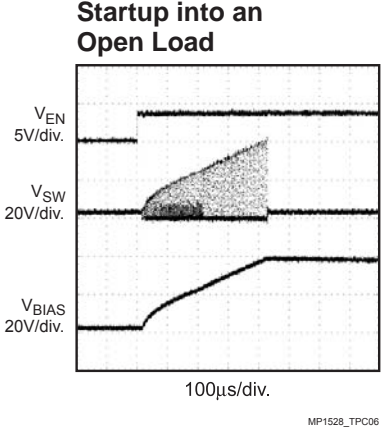
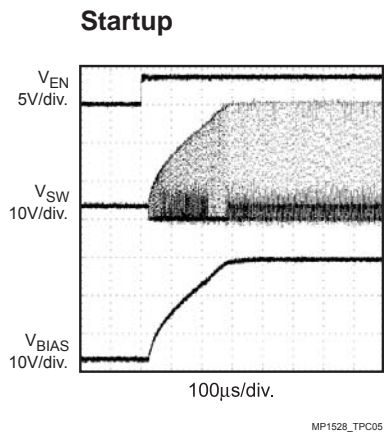
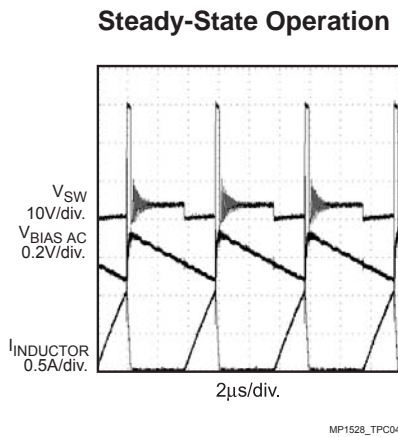
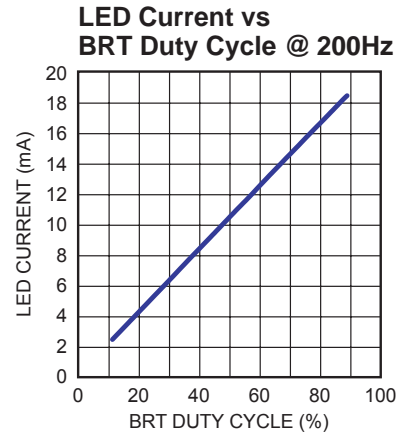
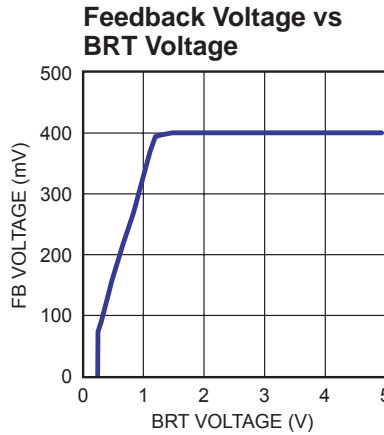
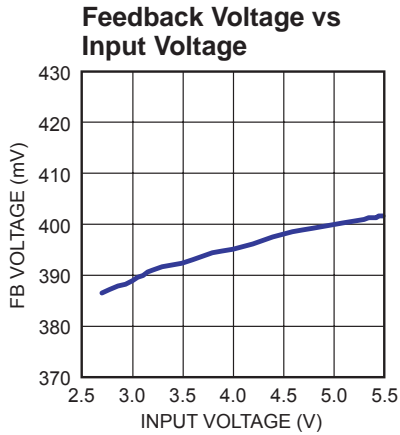

PIN FUNCTIONS

Pin #			Name	Description
QFN6	MSOP8	QFN8		
1	2	2	FB	Feedback Input. The MP1528 regulates the voltage across the current sense resistor between FB and GND. Connect a current sense resistor from the bottom of the LED string to GND and connect the bottom of the LED string to FB. The regulation threshold is set at 0.4V for $V_{BRT} \geq 1.2V$.
2	3	3	GND	Ground.
3	4	4	SW	Power Switch Output. SW is the drain of the internal MOSFET switch. Connect the power inductor and output rectifier to SW, which can swing between GND and 42V.
4	5	5	BIAS	Internal Power Input. BIAS powers the internal circuitry and measures the output voltage for open circuit protection. Connect BIAS to the output at the top of the LED string. If open circuit protection is not required, BIAS may be connected to the input source to reduce power consumption of the MP1528.
5	6	6	EN	Regulator On/Off Control Input. A high voltage applied to EN turns on the converter; a low voltage turns it off. When not used, connect EN to the input source for automatic startup. If EN is driven over 6V, place a 100k Ω resistor in series with EN. Never leave EN floating.
6	7	7	BRT	Analog or PWM Input for Controlling LED Brightness. When used in analog mode, apply a DC voltage of 0.27V to 1.2V. This input voltage is attenuated by 1/3 to set the voltage across the sense resistor at FB. Maximum brightness (20mA) occurs with an application of 1.2V. To control the brightness in PWM mode, apply a PWM signal with a minimum voltage less than 0.18V and a maximum voltage greater than 1.2V (when a voltage less than 0.18V is applied to this pin, the output switch is turned off). The regulator operates at maximum brightness when more than 1.2V is applied. The frequency of the PWM signal must be between 100Hz to 400Hz.
	1, 8	1, 8	NC	No Connect

OPERATION

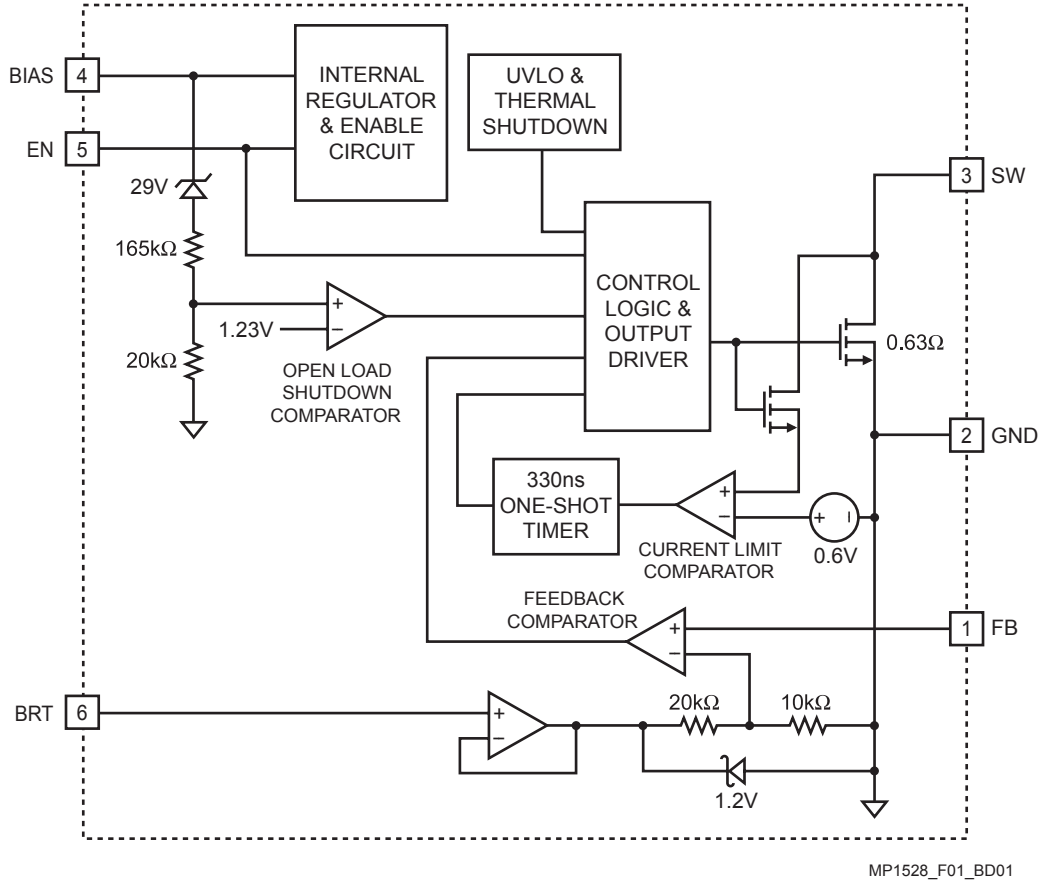

Figure 1—Functional Block Diagram

The MP1528 utilizes a constant off-time control scheme. For maximum brightness, the BRT pin is biased at or above 1.2V. Its voltage is routed through the unity gain buffer whose output is clamped at 1.2V. A resistor divider from the buffer to the inverting input of the feedback comparator divides the BRT voltage by three to set the current sense threshold. If the FB pin voltage is lower than this threshold the power MOSFET is turned on. The MOSFET and inductor currents increase until the current limit comparator trips at 950mA, turning off the MOSFET for at least 330ns. At the end of the 330ns, if the FB pin is still lower than the current sense threshold, the MOSFET is turned on again.

Analog Brightness Adjust

Analog brightness adjustments are accomplished by applying a voltage between 0.27V to 1.2V on the BRT pin.

PWM Brightness Adjust

PWM brightness adjustments are accomplished by driving the BRT pin with a digital signal whose low voltage is below 0.18V and high voltage is greater than 1.2V. A voltage below 0.18V forces the power MOSFET to turn off. A voltage greater than 1.2V will cause the FB pin to regulate at 0.4V.

Open Load Shutdown

Open Load Shutdown is implemented by connecting the BIAS pin to the top of the LED string. In the fault condition where the connection to the LED is open, V_{OUT} will rise up, as the FB pin has no voltage. Once V_{OUT} exceeds 40V, the MP1528 will cease operation until the EN pin is cycled off and on. Connecting the BIAS pin to the input will disable Open Load Shutdown.

APPLICATION INFORMATION

Setting the LED Current

The LED current is set by the voltage at BRT (V_{BRT}) and the sense resistor ($R1$) at FB. The V_{BRT} range for adjusting the LED current is 0.27V to 1.2V. Over this range, the LED current can be calculated as:

$$I_{LED} = \frac{V_{BRT}}{3 \times R1}$$

Voltages greater than 1.2V can be applied to BRT. Use 1.2V in the equation if $V_{BRT} \geq 1.2V$ or the BRT pin is left open.

For example, the LED current is set to 20mA if $V_{BRT} \geq 1.2V$ (or left open) and $R1 = 20\Omega$.

Capacitor Selection

A 4.7 μ F to 10 μ F ceramic input capacitor ($C1$) and a 0.47 μ F to 1 μ F ceramic output capacitor ($C2$) are recommended for most applications. A capacitor ($C3$, typically 1nF to 10nF) in parallel with the LED string improves stability, input ripple and output ripple, especially when large inductance values (10 μ H or above) are used. For the best stability over a wide temperature range, use capacitors with a X5R or X7R dielectric.

Inductor Selection

The MP1528 has a 950mA inductor current limit and can drive up to 9 LEDs at 20mA. Inductance values (for $L1$) from 4.7 μ H to 22 μ H

will work as well. 6.2 μ H or 6.8 μ H is a good

choice for high efficiency and small size. To prevent saturation, use an inductor with a saturation current rating that is higher than the device current limit.

Diode Selection

The MP1528's high switching frequency demands a high speed rectifier ($D1$) for optimum efficiency. A Schottky diode is recommended due to its fast recovery time and low forward voltage drop. Ensure the diode's average and peak current ratings exceed the average output current and peak inductor current. In addition, the diode's reverse breakdown voltage must exceed the output voltage.

Layout

Careful PC board layout is required due to fast switching. All components must be placed as close to the IC as possible. Keep the path between the inductor $L1$, diode $D1$, and output capacitor $C2$ extremely short for minimal noise and ringing. The feedback components such as the sense resistor $R1$ must be kept close to the FB pin to prevent noise injection on the FB pin trace. The ground return of $C1$ and $C2$ should be tied close to the GND pin. See the MP1528 demo board layout for reference.

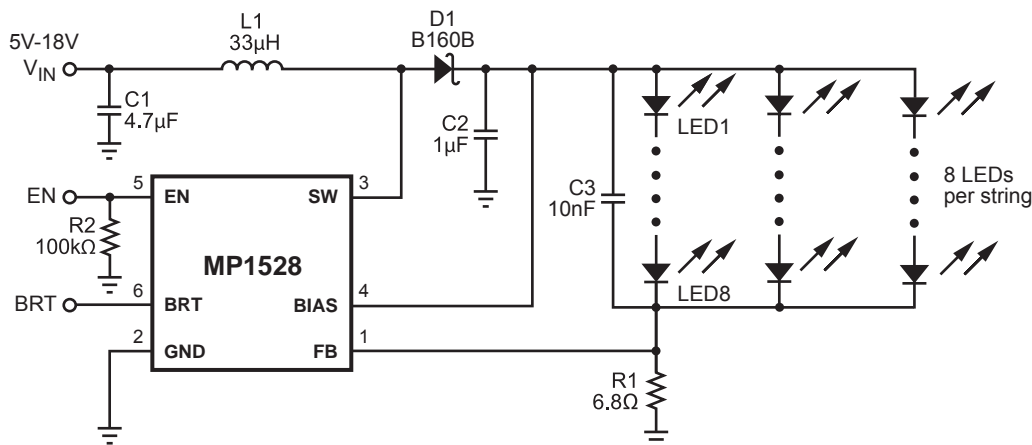
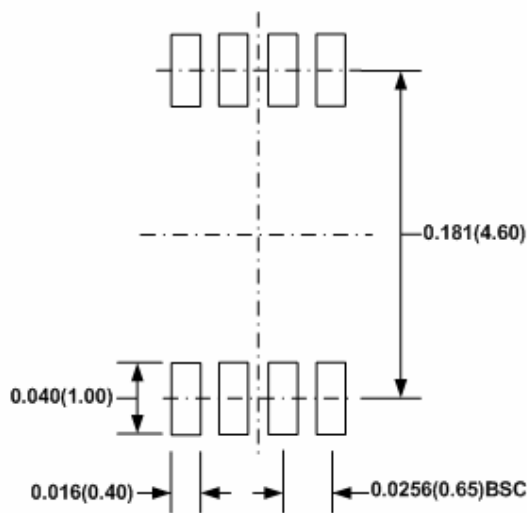
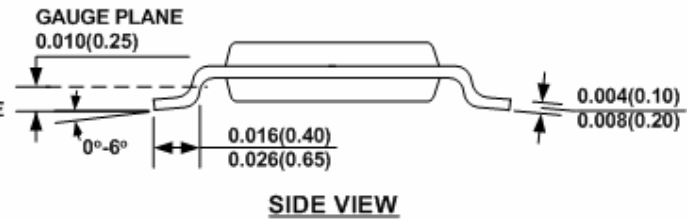
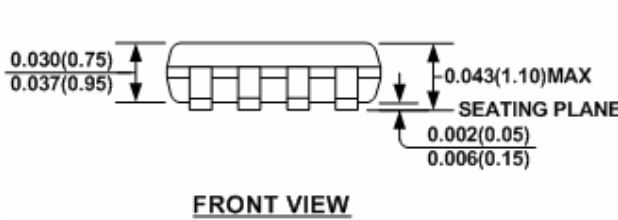
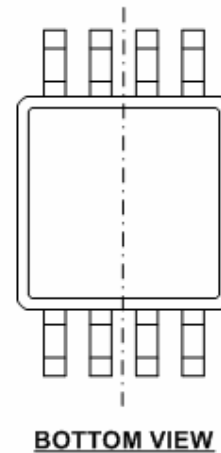
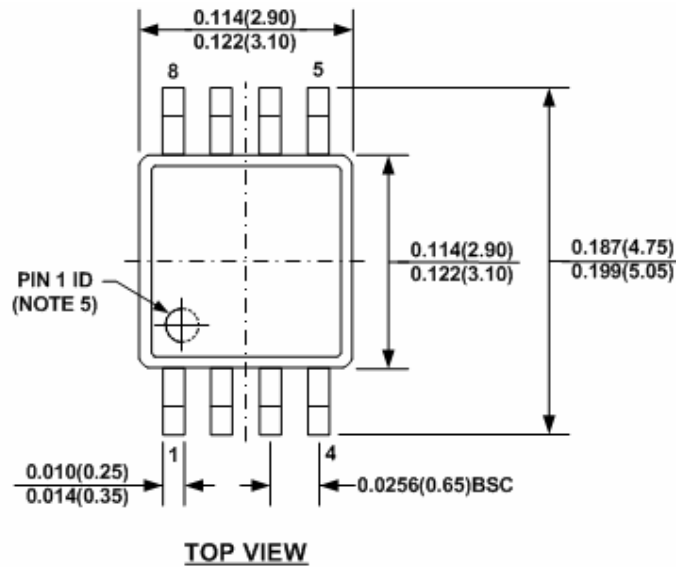

Figure 2—Driving 3 Strings of 8 LEDs in Series (60mA Total Current)

PACKAGE INFORMATION

MSOP8



NOTE:

- 1) CONTROL DIMENSION IS IN INCHES. DIMENSION IN BRACKET IS IN MILLIMETERS.
- 2) PACKAGE LENGTH DOES NOT INCLUDE MOLD FLASH, PROTRUSION OR GATE BURR.
- 3) PACKAGE WIDTH DOES NOT INCLUDE INTERLEAD FLASH OR PROTRUSION.
- 4) LEAD COPLANARITY (BOTTOM OF LEADS AFTER FORMING) SHALL BE 0.004" INCHES MAX.
- 5) PIN 1 IDENTIFICATION HAS HALF OR FULL CIRCLE OPTION.
- 6) DRAWING MEETS JEDEC MO-187, VARIATION AA.
- 7) DRAWING IS NOT TO SCALE.

QFN6 (3mm x 3mm)

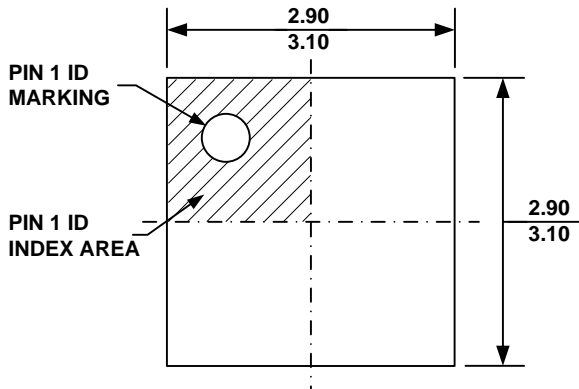

TOP VIEW

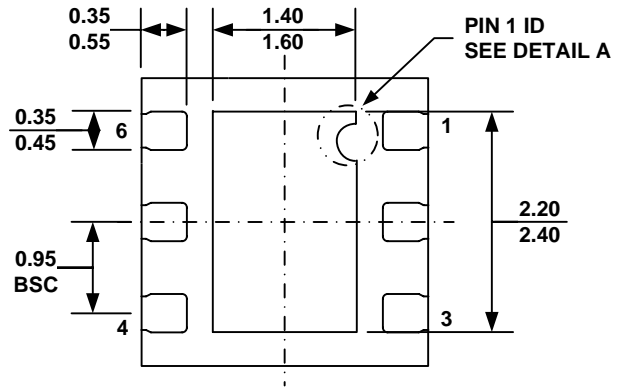

BOTTOM VIEW

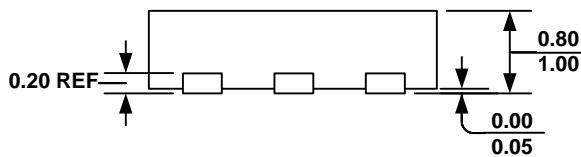

SIDE VIEW

**PIN 1 ID OPTION A
R0.20 TYP.**

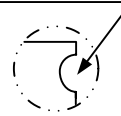

**PIN 1 ID OPTION B
R0.20 TYP.**

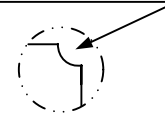

DETAIL A

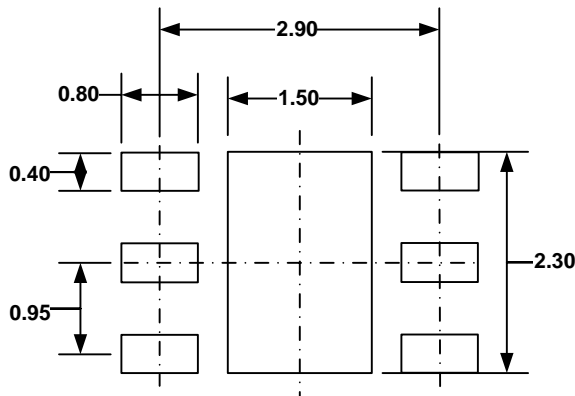

RECOMMENDED LAND PATTERN

NOTE:

- 1) ALL DIMENSIONS ARE IN MILLIMETERS.
- 2) EXPOSED PADDLE SIZE DOES NOT INCLUDE MOLD FLASH.
- 3) LEAD COPLANARITY SHALL BE 0.10 MILLIMETER MAX.
- 4) JEDEC REFERENCE IS MO-229, VARIATION VEEA-2.
- 5) DRAWING IS NOT TO SCALE.

QFN8 (2mm x 2mm)

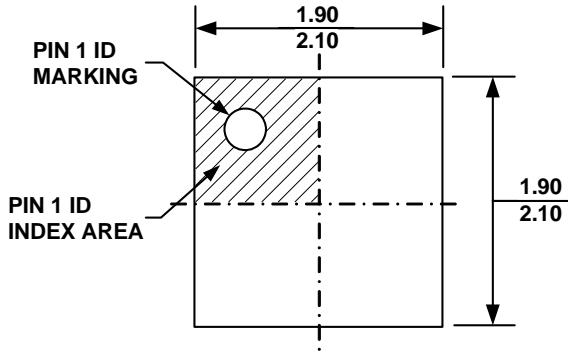

TOP VIEW

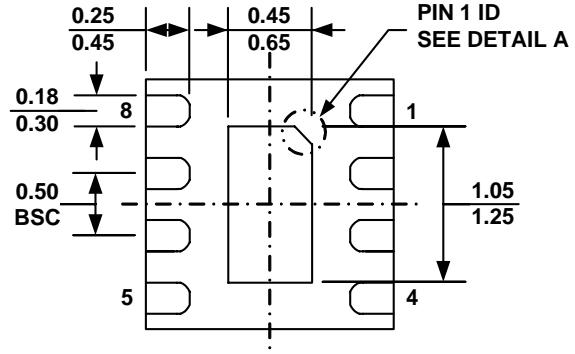

BOTTOM VIEW

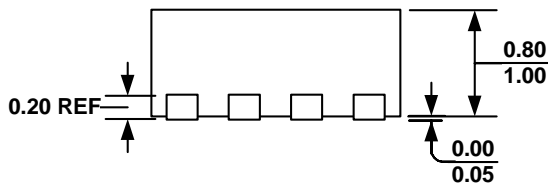

SIDE VIEW

PIN 1 ID OPTION A
0.30x45° TYP.

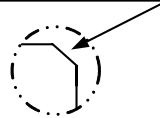

PIN 1 ID OPTION B
R0.20 TYP.

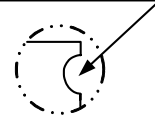

DETAIL A

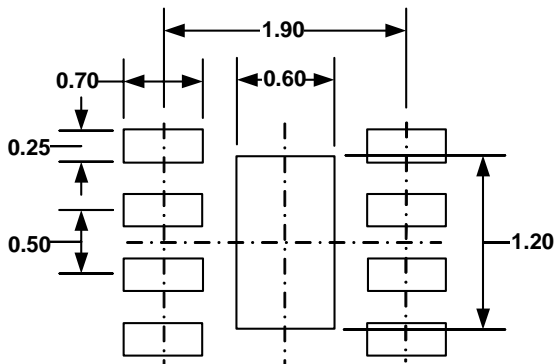

RECOMMENDED LAND PATTERN

NOTE:

- 1) ALL DIMENSIONS ARE IN MILLIMETERS.
- 2) EXPOSED PADDLE SIZE DOES NOT INCLUDE MOLD FLASH.
- 3) LEAD COPLANARITY SHALL BE 0.10 MILLIMETER MAX.
- 4) DRAWING CONFORMS TO JEDEC MO-229, VARIATION VCCD-3.
- 5) DRAWING IS NOT TO SCALE.

NOTICE: The information in this document is subject to change without notice. Please contact MPS for current specifications. Users should warrant and guarantee that third party Intellectual Property rights are not infringed upon when integrating MPS products into any application. MPS will not assume any legal responsibility for any said applications.

Компания «Океан Электроники» предлагает заключение долгосрочных отношений при поставках импортных электронных компонентов на взаимовыгодных условиях!

Наши преимущества:

- Поставка оригинальных импортных электронных компонентов напрямую с производств Америки, Европы и Азии, а так же с крупнейших складов мира;
- Широкая линейка поставок активных и пассивных импортных электронных компонентов (более 30 млн. наименований);
- Поставка сложных, дефицитных, либо снятых с производства позиций;
- Оперативные сроки поставки под заказ (от 5 рабочих дней);
- Экспресс доставка в любую точку России;
- Помощь Конструкторского Отдела и консультации квалифицированных инженеров;
- Техническая поддержка проекта, помощь в подборе аналогов, поставка прототипов;
- Поставка электронных компонентов под контролем ВП;
- Система менеджмента качества сертифицирована по Международному стандарту ISO 9001;
- При необходимости вся продукция военного и аэрокосмического назначения проходит испытания и сертификацию в лаборатории (по согласованию с заказчиком);
- Поставка специализированных компонентов военного и аэрокосмического уровня качества (Xilinx, Altera, Analog Devices, Intersil, Interpoint, Microsemi, Actel, Aeroflex, Peregrine, VPT, Syfer, Eurofarad, Texas Instruments, MS Kennedy, Miteq, Cobham, E2V, MA-COM, Hittite, Mini-Circuits, General Dynamics и др.);

Компания «Океан Электроники» является официальным дистрибьютором и эксклюзивным представителем в России одного из крупнейших производителей разъемов военного и аэрокосмического назначения «JONHON», а так же официальным дистрибьютором и эксклюзивным представителем в России производителя высокотехнологичных и надежных решений для передачи СВЧ сигналов «FORSTAR».



JONHON

«JONHON» (основан в 1970 г.)

Разъемы специального, военного и аэрокосмического назначения:

(Применяются в военной, авиационной, аэрокосмической, морской, железнодорожной, горно- и нефтедобывающей отраслях промышленности)

«FORSTAR» (основан в 1998 г.)

ВЧ соединители, коаксиальные кабели,
кабельные сборки и микроволновые компоненты:

(Применяются в телекоммуникациях гражданского и специального назначения, в средствах связи, РЛС, а так же военной, авиационной и аэрокосмической отраслях промышленности).



Телефон: 8 (812) 309-75-97 (многоканальный)

Факс: 8 (812) 320-03-32

Электронная почта: ocean@oceanchips.ru

Web: <http://oceanchips.ru/>

Адрес: 198099, г. Санкт-Петербург, ул. Калинина, д. 2, корп. 4, лит. А