

Part* Number	DESC Drawing Number	Relay Description
HD00CFW		Solid State Relay (SSR)
HD00CFY	88062-008	
HD02CFW		SSR with Switch Status
HD02CFY	88062-006	
HD20CFW		SSR with Short Circuit Protection
HD20CFY	88062-004	
HD22CFW		SSR with Short Circuit Protection and Switch Status
HD22CFY	88062-002	
HD24CFW		SSR with Short Circuit Protection and Trip Status
HD24CFY		

* The Y suffix denotes parameters tested to MIL-PRF-28750 specifications. The W suffix denotes parameters tested to Teledyne specifications.

ELECTRICAL SPECIFICATIONS

(-55°C TO +105°C UNLESS OTHERWISE NOTED)

INPUT (CONTROL) SPECIFICATION

When used in 2 terminal configuration

(TTL or direct control) (See Fig. 1)	Min	Typ	Max	Units
Input Current @ $V_{IN} = 5$ Vdc (See Fig. 2)		14	15	mAdc
Turn-Off Voltage (Guaranteed Off)			1.5	Vdc
Turn-On Voltage (Guaranteed On)	3.8			Vdc
Reverse Voltage Protection			-32	Vdc
Input Supply Range (See Note 1)	3.8		32	Vdc

INPUT (CONTROL) SPECIFICATION

When used in 3 terminal configuration

(CMOS or open collector TTL) (See Fig. 1)	Min	Typ	Max	Units
Control Current				
$V_{CONTROL} = 5$ Vdc			250	μ Adc
$V_{CONTROL} = 18$ Vdc			1	mAdc
Control Voltage Range	0		18	Vdc
Bias Supply Voltage (See Note 1)	3.8		32	Vdc
Bias Supply Current @ $V_{BIAS} = 5$ Vdc		14	15	mAdc
Turn Off Voltage (Guaranteed Off)	3.2			Vdc
Turn On Voltage (Guaranteed On)			0.3	Vdc

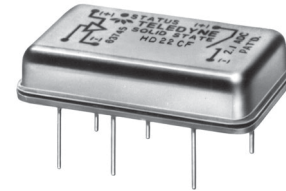

FEATURES

- Available with short-circuit/current overload protection
- Available with status output
- TTL and CMOS compatible control
- Low ON resistance power FET output
- Fast switching speed
- Meets 28 Vdc system requirements of MIL-STD-704
- Optical isolation
- Low profile hermetic package
- Built and tested to the requirements of MIL-PRF-28750
- Available to 'W' and 'Y' screening levels

DESCRIPTION

This all solid-state relay utilizes the latest technology to provide a low ON resistance and an optically isolated output. The control (input) and load (output) are optically isolated to protect input logic circuits from voltage and current transients which can occur on the output supply. The optical isolation also provides a full floating output, thus allowing the load to be connected to either output terminal. The control circuit is buffered to enable the relay to be driven directly from standard CMOS or open collector TTL logic circuits. Available options include short-circuit and current overload protection, which provides complete protection for both the relay and the system wiring. This feature not only provides protection should a short or overload occur while the relay is on, but will also provide protection should the relay be switched into a short. In either case, the relay will sense the short-circuit condition and then block it indefinitely until the short is removed and the unit is reset by cycling the input control. The second option is a status output line. This feature is available in either switch status or trip status configurations. Switch status returns the true status of the output switch and is optically isolated from the load. It provides status indication independent of the control circuit of the relay. The status line provides a logic (0) low when the input circuit is off and load circuit continuity is present. The status line provides a logic 1 (high) when the output is on. Trip status, available only with HD24 Series relays, returns a logic 0 (low) if the output trips off and a logic 1 (high) when the output is in a normal mode (on or off). These options are available either together or separately as standard features.

OUTPUT (LOAD) SPECIFICATIONS

(See Note 2)	Min	Typ	Max	Units
Continuous Load Current @ +25°C (See Fig. 3)			2.1	Adc
Leakage Current @ $V_{LOAD} = 60$ Vdc				
HD00CF, HD20CF			0.1	mA
HD24CF			0.1	mA
HD02CF			2	mA
HD22CF			2	mA
Output Voltage Drop			0.5	Vdc
Continuous Operating Load Voltage			60	Vdc
Transient Blocking Voltage (See Note 3)			80	Vdc
ON Resistance R_{ds} (on) at $T_j = 25^\circ\text{C}$			0.15	Ohm
(See Note 4)				
Turn-On Time (See Fig. 5)				
HD00CF, HD20CF			3	ms
HD24CF			2	ms
HD02CF, HD22CF			3	ms
Turn-Off Time (See Fig. 5)			1	ms
Electrical System Spike			± 600	Vdc
Output Capacitance at 25 Vdc, 100 KHz			850	pF
Input to Output Capacitance			10	pF
Dielectric Strength	1000			Vac
Insulation Resistance @ 500 Vdc	10^9			Ohm
Output Junction Temperature @ $I_{LOAD} = I_{MAX RATED}$			125	°C
Maximum Junction Temperature (T_j Max)			125	°C
Thermal Resistance Junction to Ambient (θ_{JA})			90	°C/W
Thermal Resistance Junction to Case (θ_{JC})			25	°C/W

BLOCK DIAGRAM

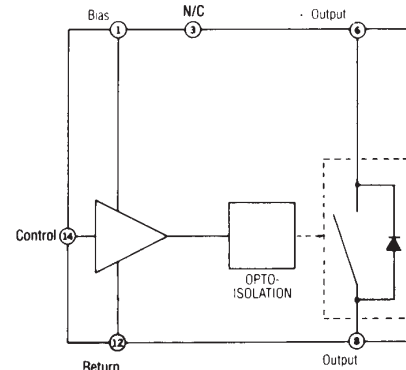

HD00CF AND HD20CF

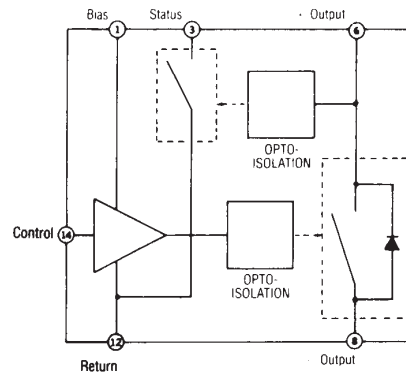

HD02CF, HD22CF, AND HD24CF

MECHANICAL SPECIFICATIONS

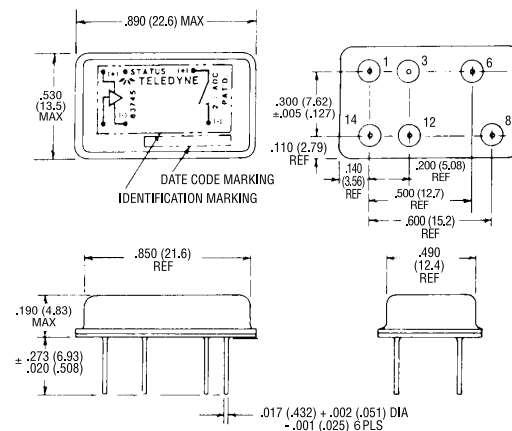

- **Weight:** 5.5 gm max
- **Case:** Hermetically sealed DIP
- **Material and Plating:**
Pins and Header: Kovar gold plated per MIL G-45204 Type III, Grade A, Class 1

DIMENSIONS ARE SHOWN IN INCHES
(MILLIMETERS)

**STATUS OUTPUT SPECIFICATIONS
(HD02CF AND HD22CF)**

(See Note 6)	Min	Typ	Max	Units
Status Supply Voltage (See Fig. 1)	1		18	Vdc
Status Leakage Current			10	μ Adc
Status (sink) Current ($V_{SO} < 0.4$ Vdc)			600	μ Adc
Status Turn-On Time (See Fig. 6)			3.5	ms
Status Turn-Off Time (See Fig. 6)			8.0	ms

**STATUS OUTPUT TRUTH TABLE
(HD02CF AND HD22CF)**

Control Voltage	Output (Switch) State	Status Output Level
High	Off	Low ($V_{SO} \leq 0.4$ Vdc)
Low	On	High ($V_{SO} = V_{STATUS}$)

ENVIRONMENTAL SPECIFICATIONS

	Min	Typ	Max	Units
Temperature Range				
Operating	-55		+105	$^{\circ}$ C
Storage	-55		+125	$^{\circ}$ C
Vibration, 100 g	10		3000	Hz
Constant Acceleration			5000	g
Shock, 11 ms pulse			50	g

**SHORT CIRCUIT PROTECTION SPECIFICATIONS
(HD20CF AND HD22CF)**

(At $T_A = 25^{\circ}$ C)	Min	Typ	Max	Units
Time to Trip Turning relay ON into a short		400		μ s
Time to Trip Shorting load while relay is ON		280		μ s

STATUS OUTPUT TRUTH TABLE (HD24CF)

Output (Switch) State	Status Output Level
Tripped	Low ($V_{SO} \leq 0.4$ Vdc)
Not Tripped	High ($V_{SO} = V_{STATUS}$)

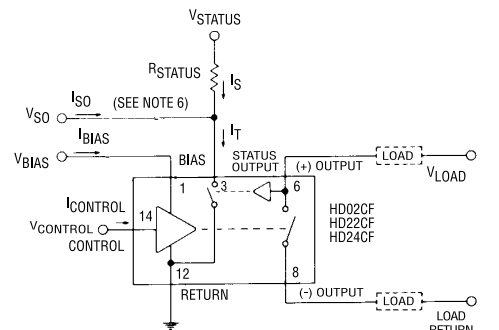

(A) 3 TERMINAL INPUT WITH STATUS (See Note 7)

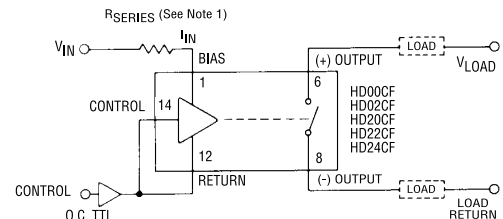

(B) 2 TERMINAL INPUT (OPEN COLLECTOR TTL DRIVE)

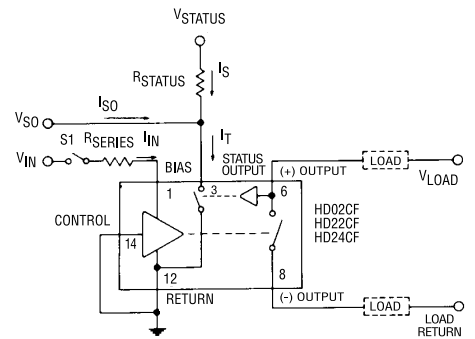

(C) 2 TERMINAL INPUT (DIRECT DRIVE) WITH STATUS

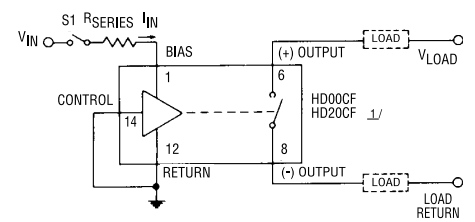

(D) 2 TERMINAL INPUT (DIRECT DRIVE)

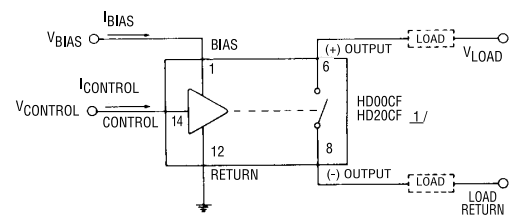

(E) 3 TERMINAL INPUT WITHOUT STATUS

1/ HD02CF and HD22CF may be wired without the status line as shown in (D) and (E) above.

WIRING CONFIGURATIONS

FIGURE 1

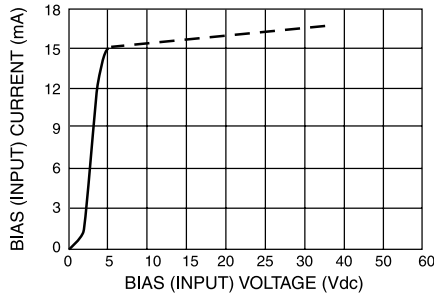

BIAS (INPUT) CURRENT VS BIAS (OUTPUT) VOLTAGE
FIGURE 2 (See Note 1)

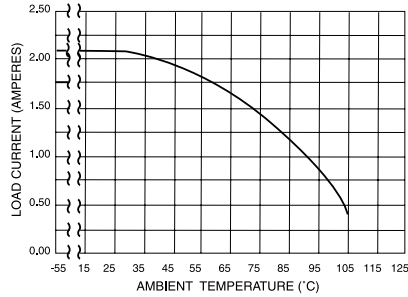

LOAD CURRENT DERATING CURVE
FIGURE 3

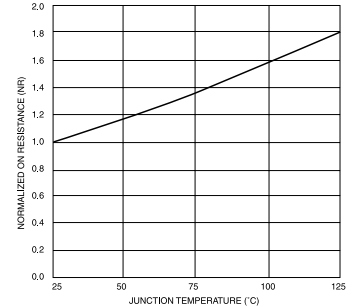

NORMALIZED ON RESISTANCE VS JUNCTION TEMPERATURE
FIGURE 4 (See Note 4)

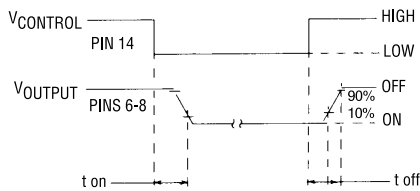

OUTPUT TURN-ON AND TURN-OFF TIMING
FIGURE 5

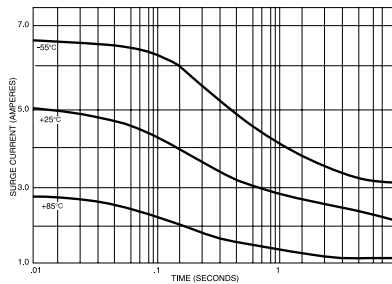

TYPICAL TRIP CURRENT VS TIME
FIGURE 7 (See Note 5)

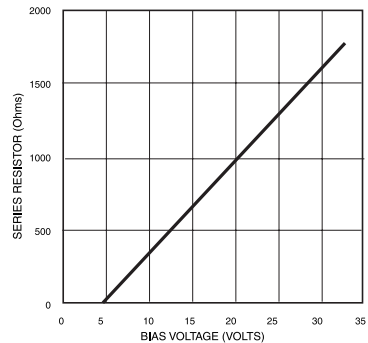

SERIES LIMIT BIAS RESISTOR VS BIAS VOLTAGE
FIGURE 8 (See Note 1)

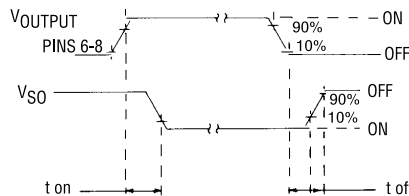

STATUS TURN-ON AND TURN-OFF TIMING (HD02CF & HD22CF)
FIGURE 6

NOTES:

- Control input is compatible with CMOS or open collector TTL (with pull up resistor). For bias voltages above 6V, a series resistor is required. Use the standard resistor value equal to or less than the value found in Figure 8.
- The rated input voltage is 5V for all tests unless otherwise specified.
- Transient blocking voltage test is performed per MIL-STD-704 (28 Vdc systems).
- To calculate the maximum ON resistance for a given junction temperature, find the normalized ON resistance factor (NR) from Figure 4. Calculate the new ON resistance as follows:

$$R_{(ON)} = NR \cdot R_{ON} @ 25^{\circ}C$$

- Overload testing to the requirements of MIL-PRF-28750 is constrained to the limits imposed by the short circuit protection characteristics as defined in this specification. System series inductance for "shorted-load" mode of operation should be 30 mH MAXIMUM. Maximum repetition rate into a shorted load should not exceed 10 Hz.
- A status pull up resistor is required for proper operation of the status output. Determine the current (I_{so}) required by the status interface. Calculate the current (I_s) through the status resistor such that the sink current through the status output is 0.6 mA. Select the status resistor such that it does not allow more than 0.6 mA to flow through the status output.

$$R_{STATUS} = \frac{V_{STATUS} - 0.4V}{0.6 mA - I_{so}}$$

- Inductive loads should be diode suppressed. Input transitions should be ≤ 1 ms duration and the input drive should be a bounceless contact type.

Компания «Океан Электроники» предлагает заключение долгосрочных отношений при поставках импортных электронных компонентов на взаимовыгодных условиях!

Наши преимущества:

- Поставка оригинальных импортных электронных компонентов напрямую с производств Америки, Европы и Азии, а так же с крупнейших складов мира;
- Широкая линейка поставок активных и пассивных импортных электронных компонентов (более 30 млн. наименований);
- Поставка сложных, дефицитных, либо снятых с производства позиций;
- Оперативные сроки поставки под заказ (от 5 рабочих дней);
- Экспресс доставка в любую точку России;
- Помощь Конструкторского Отдела и консультации квалифицированных инженеров;
- Техническая поддержка проекта, помощь в подборе аналогов, поставка прототипов;
- Поставка электронных компонентов под контролем ВП;
- Система менеджмента качества сертифицирована по Международному стандарту ISO 9001;
- При необходимости вся продукция военного и аэрокосмического назначения проходит испытания и сертификацию в лаборатории (по согласованию с заказчиком);
- Поставка специализированных компонентов военного и аэрокосмического уровня качества (Xilinx, Altera, Analog Devices, Intersil, Interpoint, Microsemi, Actel, Aeroflex, Peregrine, VPT, Syfer, Eurofarad, Texas Instruments, MS Kennedy, Miteq, Cobham, E2V, MA-COM, Hittite, Mini-Circuits, General Dynamics и др.);

Компания «Океан Электроники» является официальным дистрибьютором и эксклюзивным представителем в России одного из крупнейших производителей разъемов военного и аэрокосмического назначения «JONHON», а так же официальным дистрибьютором и эксклюзивным представителем в России производителя высокотехнологичных и надежных решений для передачи СВЧ сигналов «FORSTAR».



JONHON

«JONHON» (основан в 1970 г.)

Разъемы специального, военного и аэрокосмического назначения:

(Применяются в военной, авиационной, аэрокосмической, морской, железнодорожной, горно- и нефтедобывающей отраслях промышленности)

«FORSTAR» (основан в 1998 г.)

ВЧ соединители, коаксиальные кабели,
кабельные сборки и микроволновые компоненты:

(Применяются в телекоммуникациях гражданского и специального назначения, в средствах связи, РЛС, а так же военной, авиационной и аэрокосмической отраслях промышленности).



Телефон: 8 (812) 309-75-97 (многоканальный)

Факс: 8 (812) 320-03-32

Электронная почта: ocean@oceanchips.ru

Web: <http://oceanchips.ru/>

Адрес: 198099, г. Санкт-Петербург, ул. Калинина, д. 2, корп. 4, лит. А