

Circuits from the Lab™ Reference Circuits

Circuits from the Lab™ reference circuits are engineered and tested for quick and easy system integration to help solve today's analog, mixed-signal, and RF design challenges. For more information and/or support, visit www.analog.com/CN0254.

Devices Connected/Referenced

AD7689	16-Bit, 8-Channel, 250 kSPS PuISAR ADC
AD8608	Precision CMOS Rail-to-Rail I/O Quad Op Amp
AD8605	Precision CMOS Rail-to-Rail I/O Op Amp
ADuM3471	PWM Controller and Transformer Driver with Quad-Channel Isolators
ADP3336	500 mA anyCAP™ Adjustable Low Dropout Regulator

Low Cost, 16-Bit, 250 kSPS, 8-Channel, Isolated Data Acquisition System

EVALUATION AND DESIGN SUPPORT

Circuit Evaluation Boards

- [CN-0254 Circuit Evaluation Board \(EVAL-CN0254-SDPZ\)](#)
- [System Demonstration Platform \(EVAL-SDP-CB1Z\)](#)

Design and Integration Files

- [Schematics, Layout Files, Bill of Materials](#)

CIRCUIT FUNCTION AND BENEFITS

The circuit shown in Figure 1 is a cost effective, highly integrated 16-bit, 250 kSPS, 8-channel data acquisition system that can digitize ± 10 V industrial level signals. The circuit also provides 2500 V rms isolation between the measurement circuit and the host controller, and the entire circuit is powered from a single isolated PWM controlled 5 V supply.

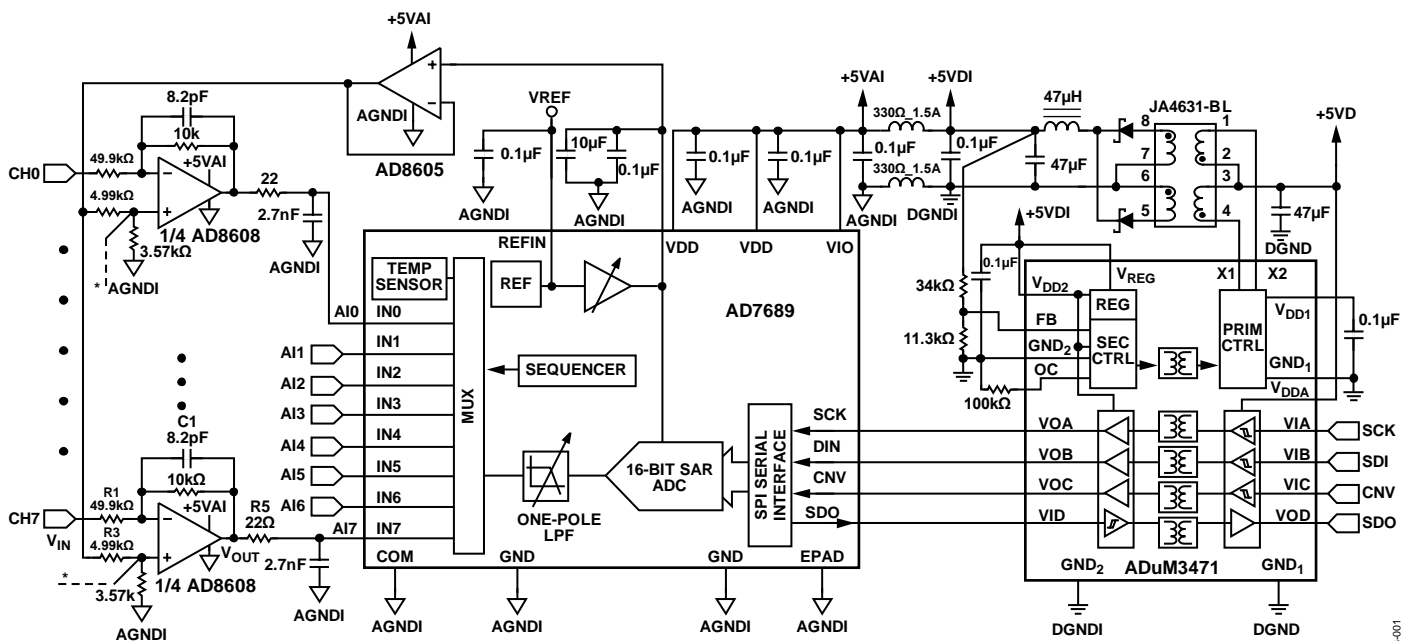

*CONNECTS TO 3 OTHER + INPUTS OF QUAD AD8608.

Figure 1. 16-Bit, 250 kSPS, 8-Channel Data Acquisition System (Simplified Schematic: All Connections and Decoupling Not Shown)

Rev. A

Circuits from the Lab™ circuits from Analog Devices have been designed and built by Analog Devices engineers. Standard engineering practices have been employed in the design and construction of each circuit, and their function and performance have been tested and verified in a lab environment at room temperature. However, you are solely responsible for testing the circuit and determining its suitability and applicability for your use and application. Accordingly, in no event shall Analog Devices be liable for direct, indirect, special, incidental, consequential or punitive damages due to any cause whatsoever connected to the use of any Circuits from the Lab circuits. (Continued on last page)

CIRCUIT DESCRIPTION

This circuit uses the [AD7689](#) 16-bit, 8-channel, 250 kSPS PulSAR ADC along with two [AD8608](#) low cost precision quad op amps to provide the entire signal conditioning and digitizing function in the data acquisition system. The only other op amp required is the [AD8605](#) that is used to buffer the reference voltage from the [AD7689](#).

The [AD8605](#) and [AD8608](#) are low cost single and quad rail-to-rail input and output CMOS amplifiers. The [AD8608](#) inverts, level shifts, and attenuates the ± 10 V input signal so that it matches the input range of the ADC, which is 0 V to +4.096 V when using a +4.096 V reference and a +5 V single supply.

The [AD8605](#) acts as an external reference buffer to provide sufficient driving ability for level shifting. The [AD8605](#) and [AD8608](#) feature very low offset voltage, low input voltage and current noise, and wide signal bandwidth, therefore making them good choices for a wide variety of applications. The low current and voltage noise of the [AD8608](#) ensures that the resistor noise is the dominant term in the output noise for high input impedance. In the circuit, the input impedance (equal to $R1$) is 50 k Ω .

The [AD7689](#) 16-bit, 8-channel, 250 kSPS PulSAR ADC contains all the necessary components for the multichannel low power data acquisition system. It includes a 16-bit SAR ADC, an 8-channel low crosstalk multiplexer, a low drift reference and buffer, a temperature sensor, a selectable one-pole filter, and a channel sequencer. The sequencer is useful for continuously scanning channels, and a microcontroller or FPGA is not required to control channel switching. The [AD7689](#) is packaged in a tiny 20-lead 4 mm \times 4 mm LFCSP footprint, thereby minimizing cost and printed circuit board (PCB) area. Operation is specified from -40°C to $+85^{\circ}\text{C}$. Power dissipation with a 5 V supply at 250 kSPS is 12.5 mW (typical).

The [ADuM3471](#) is a quad-channel digital isolator with an integrated PWM controller and transformer driver for an isolated dc-to-dc converter. The [ADuM3471](#) provides the isolated 5 V, 2 W power for the circuit as well as isolates the digital signals at the SPI interface.

Analog Front End Design

Signal levels of up to ± 10 V are typical in process control and industrial automation systems. An inverting amplifier with attenuation and level shifting is used in the Figure 1 circuit to convert the ± 10 V signal into one that fits the range of the ADC.

The equation of the circuit is as follows:

$$V_{OUT} = -\frac{R2}{R1} \times V_{IN} + \left(\frac{R1+R2}{R1}\right) \times \left(\frac{R4}{R3+R4}\right) \times V_{REF} \quad (1)$$

The signal gain ($-R2/R1$) of the front end is set to -0.2 so that the range of the signal into the ADC is 4 V peak-to-peak. This fits the input range of 0 V to 4.096 V, which is equal to the reference voltage, V_{REF} .

$$\frac{R1}{R2} = 5 \quad (2)$$

For a 0 V input signal, the output of the op amp should be at midscale or $0.5 V_{REF}$.

$$\left(\frac{R1+R2}{R1}\right) \times \left(\frac{R4}{R3+R4}\right) = 0.5 \quad (3)$$

Substituting Equation 1 in Equation 2 yields

$$\frac{R3}{R4} = 1.4 \quad (4)$$

The common-mode voltage at the input of the op amp is calculated by

$$V_{CM} = V_{REF} \times \left(\frac{R4}{R3+R4}\right) \quad (5)$$

For $R3/R4 = 1.4$ and $V_{REF} = 4.096$ V, the common-mode voltage of the op amp is 1.7 V.

There are four amplifiers in each [AD8608](#), and the four noninverting inputs are shorted together and connected to a resistor divider, $R3/R4$. A second divider is used for the second [AD8608](#). To cancel the op amp input bias currents,

$$R1 || R2 = 4 (R3 || R4) \quad (6)$$

The input impedance of the circuit is $R1$, which should ideally be high. However, a resistor has thermal noise which is proportional to the square root of resistance, and therefore, the system noise performance degrades as this resistor value increases. A simple noise analysis is needed to determine the optimum value.

Based on the Nyquist criteria, the maximum signal frequency component should be less than half of the maximum sample rate. The [AD7689](#) 250 kSPS sampling rate yields a Nyquist frequency of 125 kHz. To minimize the attenuation of a signal in this bandwidth, the -3 dB cutoff frequency of the front end is designed to be about 12 times the Nyquist frequency or 1.5 MHz.

The noise model of this circuit is shown in Figure 2. There are three noise sources in this circuit: resistor noise, amplifier voltage noise, and amplifier current noise. The rms value of each noise source is shown in Table 1. See Application Note [AN-358](#), and the [MT-047](#), [MT-048](#), and [MT-049](#) tutorials for more details about op amp noise.

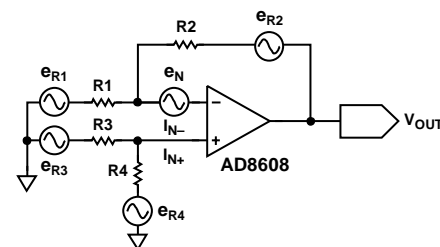

Figure 2. Noise Model for Inverting Configuration of the [AD8608](#)

The total rms noise in front of the ADC within the bandwidth of interest should be less than 0.5 LSB so that the input signal can be digitized correctly by the ADC.

The noise from the resistors can be calculated out by the following equation:

$$e_R = 4 \times \sqrt{\frac{R}{1000}} \text{ nV} / \sqrt{\text{Hz}} \text{ at } 25^\circ\text{C} \quad (7)$$

where R is in Ω .

The noise performance using the resistor values shown in Figure 1 and a bandwidth of 1.5 MHz is summarized in Table 1.

These uncorrelated noise voltages add in a root-sum-of-squares manner; therefore, the total op amp output rms noise within the 1.5 MHz bandwidth is approximately 21.3 μV . For a 4.096 V reference, the LSB for 16 bits is 62.5 μV . The rms noise of 21.3 μV is less than 0.5 LSB, and the resistor values shown in Figure 1 are suitable for this application.

Note that the largest contributor to the total output noise is the resistor R2, which is 10 k Ω in the circuit. Reducing the value of R2 requires a proportional reduction in R1, which reduces the input impedance.

The input current noise of the AD8608 is so small that it does not become a significant term unless extremely large resistor values are used. The low input current noise and input bias current of the AD8605 and AD8608 make them ideal amplifiers for high impedance sensors such as photodiodes.

The C1 capacitor is added in parallel with R2 to form a single-pole, active low-pass filter. The bandwidth is calculated using Equation 7. Given the 1.5 MHz, -3 dB bandwidth, C1 is about 10 pF. In the circuit, a value of 8.2 pF was chosen considering the parasitic effects of PCB board.

$$f_{-3dB} = \frac{1}{2\pi R2 \times C2} \quad (8)$$

Analog-to-Digital Converter (ADC)

The AD7689 is a modern SAR ADC and uses an internal switched capacitor DAC. Because of the SAR architecture, there is no pipeline delay in the conversion process, thereby greatly simplifying multiplexed operation. The equivalent analog input circuit is shown in Figure 3. Small transient currents are injected on the analog input at the sampling frequency, and the external filter network composed of R5 and C2 reduces their effect on the op amp output. In addition, the filter has a bandwidth of 2.7 MHz and reduces noise at the ADC input.

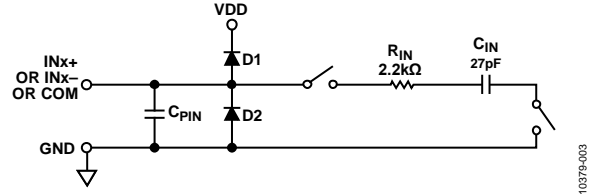

Figure 3. Equivalent Analog Input Circuit of AD7689

With 4.096 V or 2.5 V selectable reference, the input range of this circuit can be switched between ± 10 V and ± 6 V without degrading the system resolution.

The internal temperature sensor can be used to monitor the junction temperature of the AD7689 and allows system calibration and temperature compensation in precision applications.

Table 1. Noise Summary for the Circuit Values Shown in Figure 1

Noise Source	RMS Noise Density	RTO Factor (Equation)	RTO Factor	Output Noise Density (nV/ $\sqrt{\text{Hz}}$)	Output RMS Noise, 1.5 MHz Bandwidth (μV)
e_{R1}	28 nV/ $\sqrt{\text{Hz}}$	$\frac{R2}{R1}$	0.2	5.6	6.9
e_{R2}	12.6 nV/ $\sqrt{\text{Hz}}$	1	1	12.6	15.4
e_{R3}	9 nV/ $\sqrt{\text{Hz}}$	$\left(1 + \frac{R2}{R1}\right) \times \left(\frac{R4}{R3 + R4}\right)$	0.5	4.5	5.5
e_{R4}	8 nV/ $\sqrt{\text{Hz}}$	$\left(1 + \frac{R2}{R1}\right) \times \left(\frac{R3}{R3 + R4}\right)$	0.7	5.6	6.9
e_n	6.5 nV/ $\sqrt{\text{Hz}}$	$1 + \frac{R2}{R1}$	1.2	7.8	9.6
i_{n+}	0.01 pA/ $\sqrt{\text{Hz}}$	$\left(1 + \frac{R2}{R1}\right) \times \left(\frac{R3 \times R4}{R3 + R4}\right)$	2.5 k Ω	0.025	0.03
i_{n-}	0.01 pA/ $\sqrt{\text{Hz}}$	R2	10 k Ω	0.1	0.12

One-Chip Solution for Isolated Power and Digital I/O

The **ADuM3471** is a single chip solution for both power and digital I/O isolation. The isolation voltage is 2500 V rms (recognized under UL 1577). The **ADuM3471** provides a 4-channel isolated I/O port and an integrated PWM controller and transformer driver for an isolated dc-to-dc converter. Combined with a few external components, the **ADuM3471** can provide 2 W isolated power with any regulated voltage from 3 V to 24 V. The necessary external components are one transformer for power energy transmission, two Schottky diodes for full wave rectification, an LC filter for ripple suppression, and two feedback resistors to set the output voltage. See the **ADuM3471** data sheet and Figure 1 for more details.

Layout Considerations

The performance of this or any other high speed or high resolution circuit is highly dependent on proper PCB layout. This includes, but is not limited to, power supply bypassing, signal routing, and proper power planes and ground planes. See [Tutorial MT-031](#), [Tutorial MT-101](#), and the article [A Practical Guide to High-Speed Printed-Circuit-Board Layout](#), *Analog Dialogue* 39-09, September 2005 for more detailed information regarding PCB layout.

A complete design support package for **CN-0254** containing schematics, board layout, and BOM is located at <http://www.analog.com/CN0254-DesignSupport>.

System Performance

Figure 4 shows a plot of the ADC code occurrences for 10,000 samples (1 sec at 1 kSPS) when CH0 through CH7 are shorted to GND on the terminal block of the evaluation board. Note that 95% of the codes fall within 4 LSBs, and the peak-to-peak spread is approximately 7 LSBs. This corresponds to an rms value of approximately $7 \div 6.6 = 1.1$ LSB.

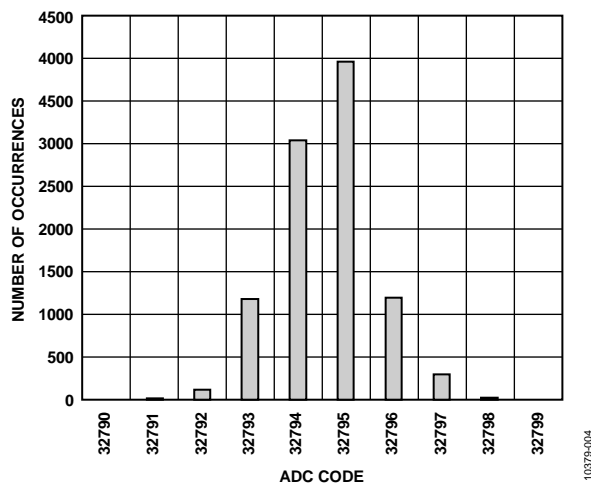

Figure 4. DC Histogram for a 0 V Input, 10,000 Samples

The ac performance is shown in Figure 5. The sampling rate 250 kSPS is controlled by the system demonstration platform (**EVAL-SDP-CB1Z SDP**), and the digital signal processing including the signal windowing and FFT is calculated on a PC by the **CN-0254** evaluation software. The input sine waveform is a 20 kHz tone provided by a low distortion B&K sine generator, Type 1051.

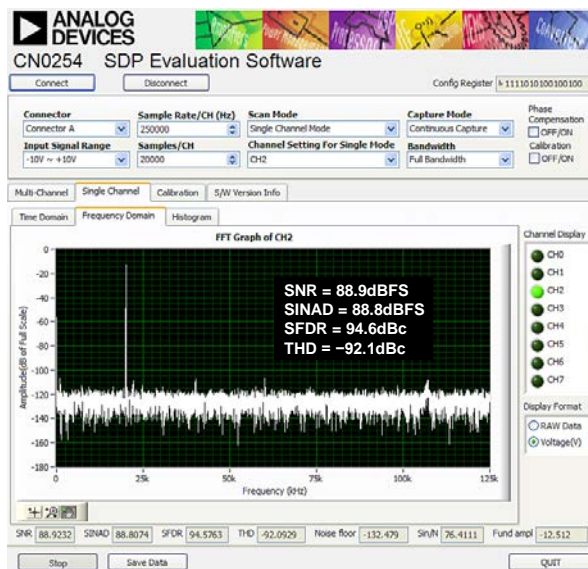

Figure 5. FFT with a Kaiser Window (Parameter = 20), 20 kHz Input, 250 kSPS Sampling Rate

COMMON VARIATIONS

For applications needing higher sampling rates, the **AD7699** samples up to 500 kSPS and is the ideal pin-for-pin replacement for the **AD7689**.

The **AD8615**, **AD8616**, and **AD8618** are single/dual/quad precision, CMOS, rail-to-rail input/output op amps with bandwidths up to 20 MHz. They can be used in applications requiring more bandwidth than the **AD8605/AD8608** series.

The **ADR3412** (1.200 V), **ADR3420** (2.048 V), **ADR3425** (2.500 V), **ADR3430** (3.000 V), **ADR3433** (3.300 V), **ADR3440** (4.096 V), and **ADR3450** (5.000 V) are low cost, low power, high precision CMOS voltage references, featuring $\pm 0.1\%$ initial accuracy, low operating current, and low output noise in a small SOT-23 package. These can be used instead of the **AD7689** internal reference, if desired.

The **ADuM3470**, **ADuM3471**, **ADuM3472**, **ADuM3473**, and **ADuM3474** are ideal choices for applications that need isolation for both power and digital I/O. The **ADuM120x** and **ADuM140x** families are used for isolated I/O extension. For high data rates, the **ADuM344x** family supports up to 150 Mbps.

CIRCUIT EVALUATION AND TEST

Equipment Needed (Equivalents Can Be Substituted)

- PC with a USB port and Windows® XP, Windows Vista (32-bit), or Windows 7 (32-bit).
- EVAL-CN0254-SDPZ circuit evaluation board
- EVAL-SDP-CB1Z system demonstration platform evaluation board
- Power supply: 6 V dc, 500 mA
- CN0254 evaluation software
- B&K Sine Generator Type 1051

Getting Started

Load the evaluation software by placing the CN-0254 evaluation software CD in the CD drive of the PC. Using **My Computer**, locate the drive that contains the evaluation software CD and open the **Readme** file. Follow the instructions contained in the **Readme** file for installing and using the evaluation software.

Functional Block Diagram

Figure 6 shows a functional block diagram of the test setup. The EVAL-CN0254-SDPZ-PADSSchematic pdf file contains the detailed circuit schematics for the CN-0254 evaluation board. The CN-0254 Design Support Package including schematics, PCB layout, BOM, and Gerber files can be downloaded at: <http://www.analog.com/CN0254-DesignSupport>.

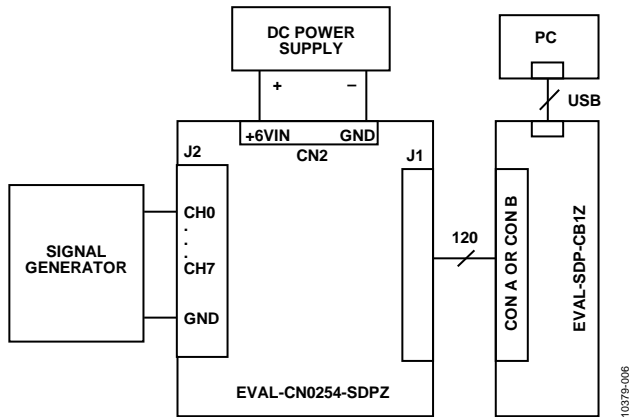

Figure 6. Evaluation Test Setup

Setup and Test

Connect the 120-pin connector on the CN-0254 evaluation circuit board to the CON A or CON B connector on the EVAL-SDP-CB1Z evaluation (SDP) board. Use nylon hardware to firmly secure the two boards, using the holes provided at the ends of the 120-pin connectors. After successfully setting the dc output supply to 6 V output, turn the power supply off. Connect 6 V to CN2. Turn on the power supply and then connect the SDP to the PC by using the USB-to-miniUSB cable.

After setting up the power supply and connecting it to the EVAL-CN0254-SDPZ circuit board, launch the evaluation software. Click **Connect** so that the software can communicate with the SDP board. The SDP board can be used to send, receive, and capture serial data from the EVAL-CN0254-SDPZ board. The data in this circuit note was generated using a B&K sign generator, Type 1051. Information regarding the SDP board can be found at: www.analog.com/SDP.

LEARN MORE

CN0254 Design Support Package:

<http://www.analog.com/CN0254-DesignSupport>

Lewis Smith and D.H. Sheingold, *Noise and Operational Amplifier Circuits*, Application Note AN-358, Analog Devices.

Martin Murnane, Chris Augusta. *Understanding PulSAR ADC Support Circuitry*, Application Note AN-931, Analog Devices.

Ardizzoni, John. *A Practical Guide to High-Speed Printed-Circuit-Board Layout*, Analog Dialogue 39-09, September 2005.

MT-031 Tutorial, *Grounding Data Converters and Solving the Mystery of "AGND" and "DGND"*, Analog Devices.

MT-047 Tutorial, *Op Amp Noise*, Analog Devices.

MT-048 Tutorial, *Op Amp Noise Relationships: 1/f Noise, RMS Noise, and Equivalent Noise Bandwidth*, Analog Devices.

MT-049 Tutorial, *Op Amp Total Output Noise Calculations for Single-Pole System*, Analog Devices

MT-101 Tutorial, *Decoupling Techniques*, Analog Devices.

CN0225 Circuit Note, *High Impedance, High CMR, ±10 V Analog Front End Signal Conditioner for Industrial Process Control and Automation*, Analog Devices

CN0261 Circuit Note, *Optimizing AC Performance in an 18-Bit, 250 kSPS, PulSAR Measurement Circuit*, Analog Devices.

UG-197 User Guide, *iCoupler ADuM347x Quad-Channel Isolators with Integrated Transformer Driver Evaluation Board*, Analog Devices.

Data Sheets and Evaluation Boards

[CN-0254 Circuit Evaluation Board \(EVAL-CN0254-SDPZ\)](#)

[System Demonstration Platform \(EVAL-SDP-CB1Z\)](#)

[AD7689 Data Sheet and Evaluation Board](#)

[AD8608 Data Sheet and Evaluation Board](#)

[AD8605 Data Sheet and Evaluation Board](#)

[ADuM3471 Data Sheet and Evaluation Board](#)

REVISION HISTORY

5/12—Rev. 0 to Rev. A

Changes to Figure 1 1

4/12—Revision 0: Initial Version

(Continued from first page) Circuits from the Lab circuits are intended only for use with Analog Devices products and are the intellectual property of Analog Devices or its licensors. While you may use the Circuits from the Lab circuits in the design of your product, no other license is granted by implication or otherwise under any patents or other intellectual property by application or use of the Circuits from the Lab circuits. Information furnished by Analog Devices is believed to be accurate and reliable. However, Circuits from the Lab circuits are supplied "as is" and without warranties of any kind, express, implied, or statutory including, but not limited to, any implied warranty of merchantability, noninfringement or fitness for a particular purpose and no responsibility is assumed by Analog Devices for their use, nor for any infringements of patents or other rights of third parties that may result from their use. Analog Devices reserves the right to change any Circuits from the Lab circuits at any time without notice but is under no obligation to do so.



Компания «Океан Электроники» предлагает заключение долгосрочных отношений при поставках импортных электронных компонентов на взаимовыгодных условиях!

Наши преимущества:

- Поставка оригинальных импортных электронных компонентов напрямую с производств Америки, Европы и Азии, а так же с крупнейших складов мира;
- Широкая линейка поставок активных и пассивных импортных электронных компонентов (более 30 млн. наименований);
- Поставка сложных, дефицитных, либо снятых с производства позиций;
- Оперативные сроки поставки под заказ (от 5 рабочих дней);
- Экспресс доставка в любую точку России;
- Помощь Конструкторского Отдела и консультации квалифицированных инженеров;
- Техническая поддержка проекта, помощь в подборе аналогов, поставка прототипов;
- Поставка электронных компонентов под контролем ВП;
- Система менеджмента качества сертифицирована по Международному стандарту ISO 9001;
- При необходимости вся продукция военного и аэрокосмического назначения проходит испытания и сертификацию в лаборатории (по согласованию с заказчиком);
- Поставка специализированных компонентов военного и аэрокосмического уровня качества (Xilinx, Altera, Analog Devices, Intersil, Interpoint, Microsemi, Actel, Aeroflex, Peregrine, VPT, Syfer, Eurofarad, Texas Instruments, MS Kennedy, Miteq, Cobham, E2V, MA-COM, Hittite, Mini-Circuits, General Dynamics и др.);

Компания «Океан Электроники» является официальным дистрибьютором и эксклюзивным представителем в России одного из крупнейших производителей разъемов военного и аэрокосмического назначения «JONHON», а так же официальным дистрибьютором и эксклюзивным представителем в России производителя высокотехнологичных и надежных решений для передачи СВЧ сигналов «FORSTAR».



JONHON

«JONHON» (основан в 1970 г.)

Разъемы специального, военного и аэрокосмического назначения:

(Применяются в военной, авиационной, аэрокосмической, морской, железнодорожной, горно- и нефтедобывающей отраслях промышленности)

«FORSTAR» (основан в 1998 г.)

ВЧ соединители, коаксиальные кабели, кабельные сборки и микроволновые компоненты:

(Применяются в телекоммуникациях гражданского и специального назначения, в средствах связи, РЛС, а так же военной, авиационной и аэрокосмической отраслях промышленности).



Телефон: 8 (812) 309-75-97 (многоканальный)

Факс: 8 (812) 320-03-32

Электронная почта: ocean@oceanchips.ru

Web: <http://oceanchips.ru/>

Адрес: 198099, г. Санкт-Петербург, ул. Калинина, д. 2, корп. 4, лит. А